

Set-up Instructions

1983 Model ATC 110



AMERICAN HONDA MOTOR CO., INC.
100 WEST ALONDRA BOULEVARD, GARDENA, CALIFORNIA 90247

WARNING

WARNING

WARNING

WARNING

SET-UP AND PRE-DELIVERY SERVICE MUST BE PERFORMED BY AN AUTHORIZED HONDA MOTORCYCLE DEALER. Proper set-up and pre-delivery service is essential to rider safety and reliability of the ATC. When a customer takes delivery of his brand new ATC, he expects it to be in excellent running condition. There are few things that will cause greater customer dissatisfaction than poor preparation of a new unit. An error or oversight made by the mechanic assembling and servicing a new unit can easily result in faulty operation, damage to the machine, or even injury to the rider.

NOTE: The black vertical bars near the edge of the pages as shown here indicate changes. Read carefully.



NOTE: Right and left are determined from the rider's view.

SET-UP INSTRUCTION REVISED PAGES

Pages Affected	Orig. Issue Date	Rev. Date
1 through 18	8/82	Original
1, 2, and 12	8/82	10/82

Remove and destroy superseded pages.

Pay special attention to warnings, cautions, and notes.

WARNING means hazards or unsafe practices which could cause severe personal injury or death.

CAUTION: means hazards or unsafe practices which could cause minor personal injury or product or property damage.

NOTE: gives helpful information.

This page supersedes page 2 dated 8/82. Remove and destroy superseded page.

Rev. 10/82

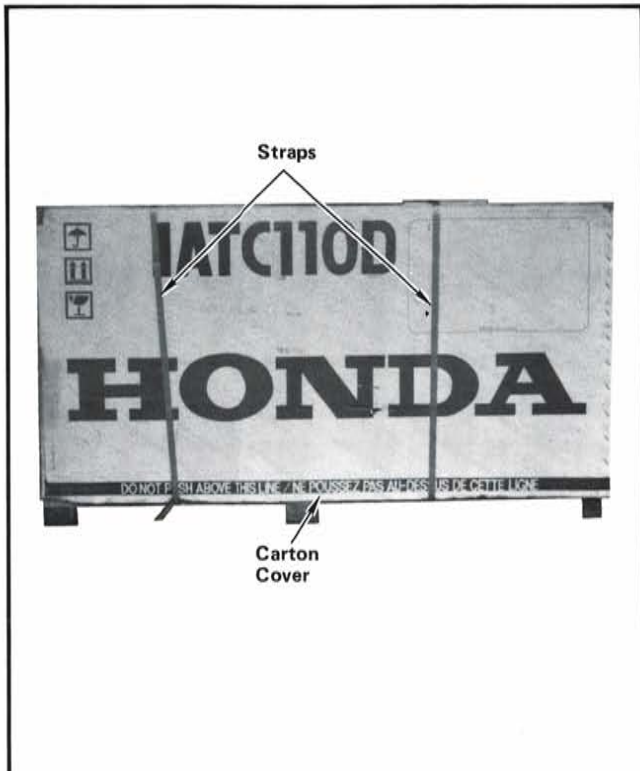

STEP 1—Cut straps and remove carton cover by lifting it up.

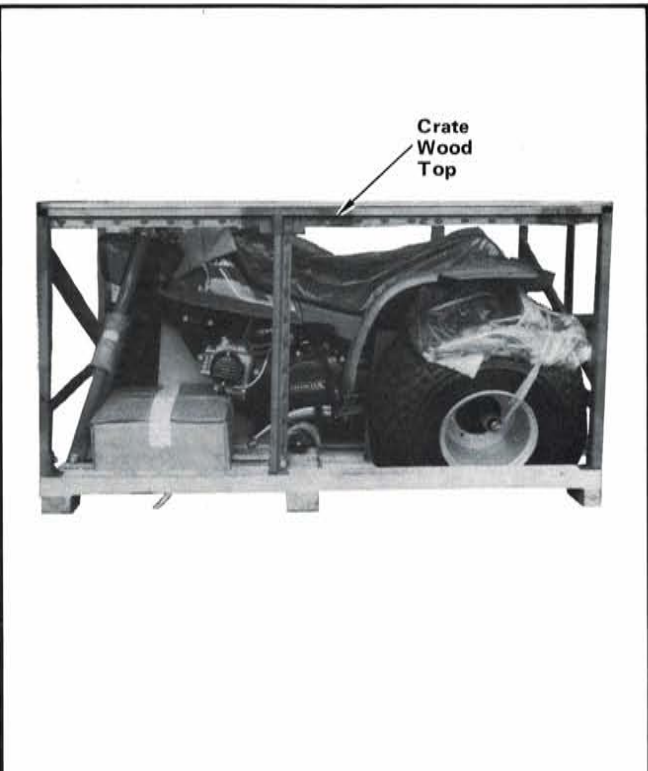

STEP 2—Remove crate wood top.

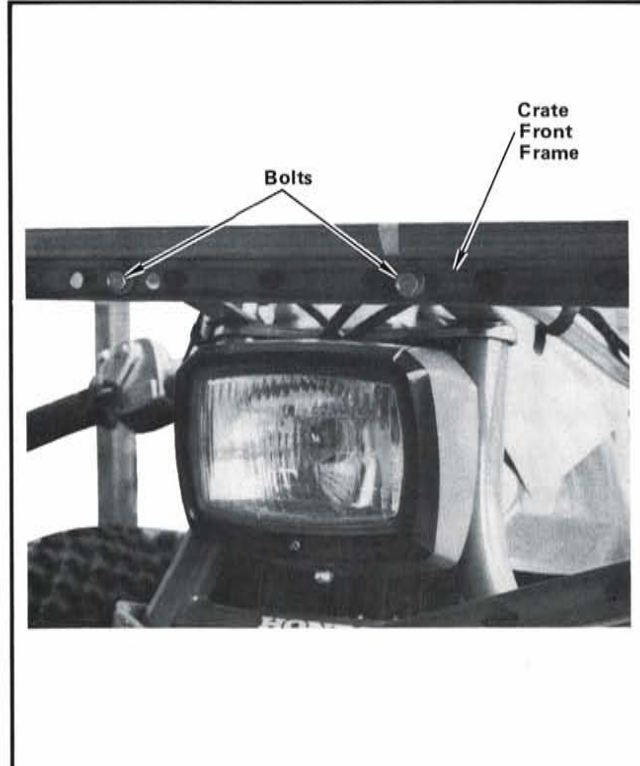

STEP 3—Remove two bolts attaching crate front frame to front shipping bracket.

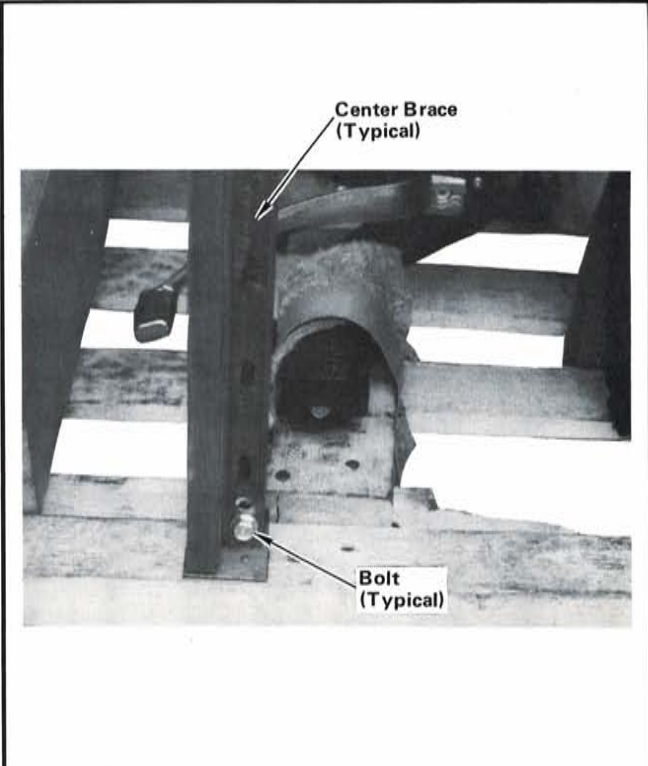

STEP 4—Remove bolts attaching center braces to crate base.

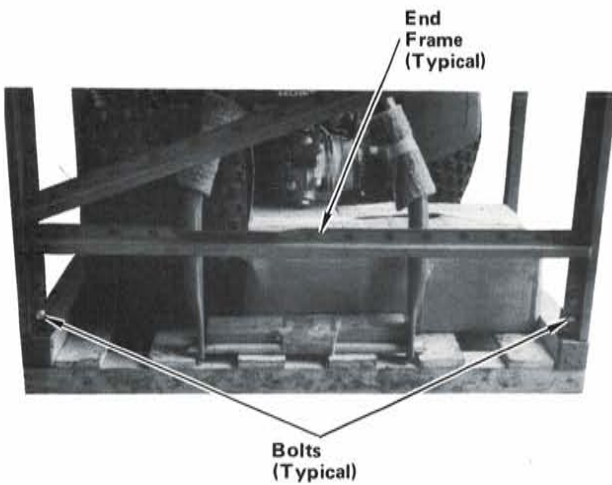

STEP 5—Remove bolts attaching front and rear end frames to crate base. Carefully lift off crate frame using two people.

CAUTION: Use extreme care not to damage ATC with crate frame.

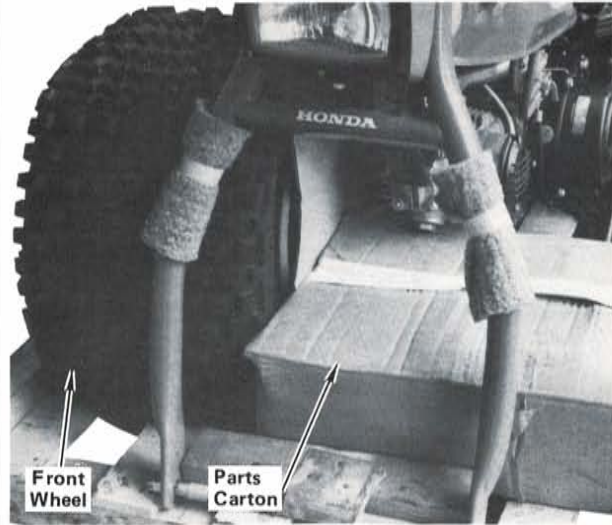

STEP 6—Remove front wheel and parts carton from crate base.

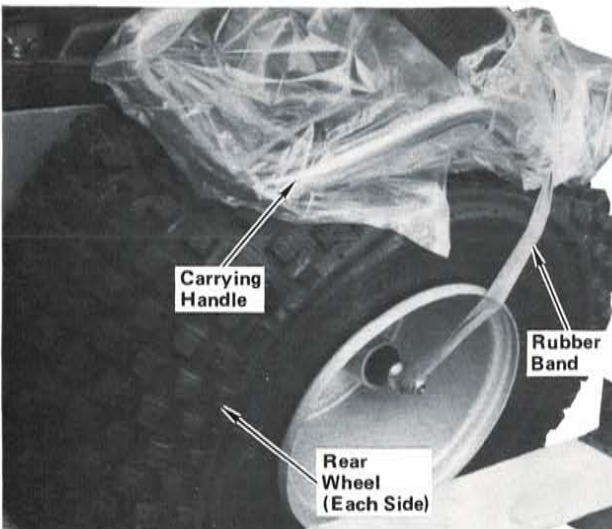

STEP 7—Remove rear wheels and rear carrying handle by removing rubber bands.

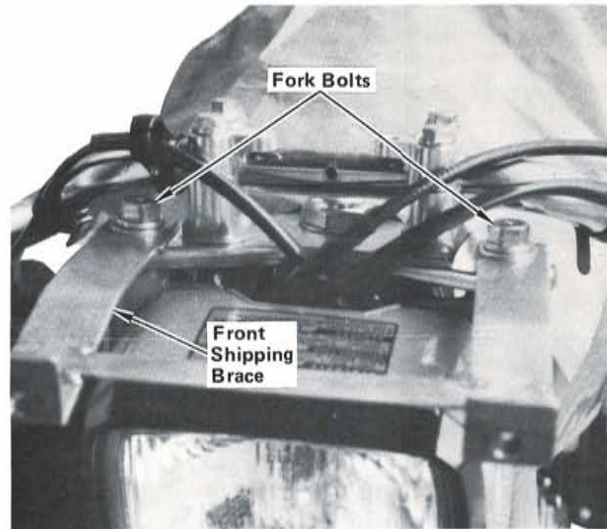

STEP 8—Loosen fork bolts and remove front shipping brace. Retighten fork bolts to specified torque.

Torque specification:
6 kg-m (44 lb-ft)

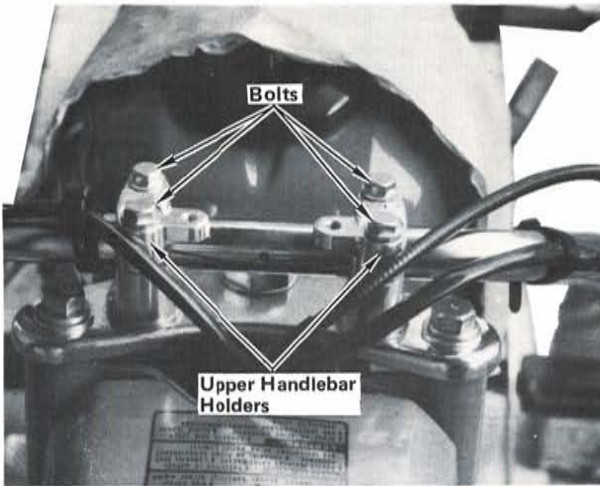

STEP 9—Loosen four bolts attaching upper handlebar holders.

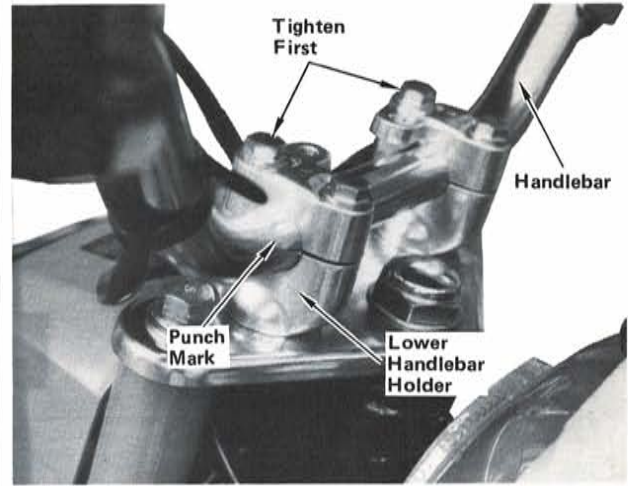

STEP 10—Raise handlebar grips until punch mark on handlebar is aligned with top of lower holder and serrations are aligned with lower holders. Tighten forward bolts to specified torque first, then tighten rear bolts to same torque.

Torque specification:
2.4 kg-m (18 lb-ft)

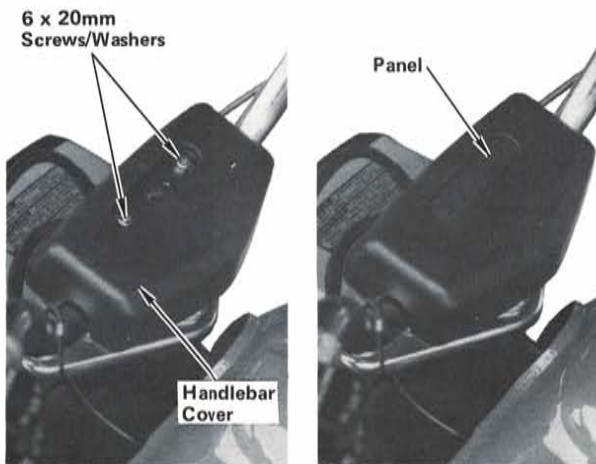

STEP 11—Remove panel from handlebar cover and install cover as shown using two 6 x 20 mm screws/washers. Tighten screws securely and reinstall panel as shown.

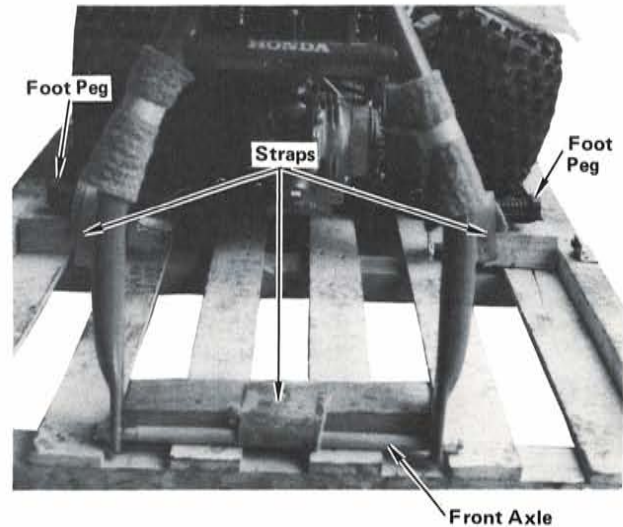

STEP 12—Remove straps holding front axle and foot pegs to crate base, by removing nails.

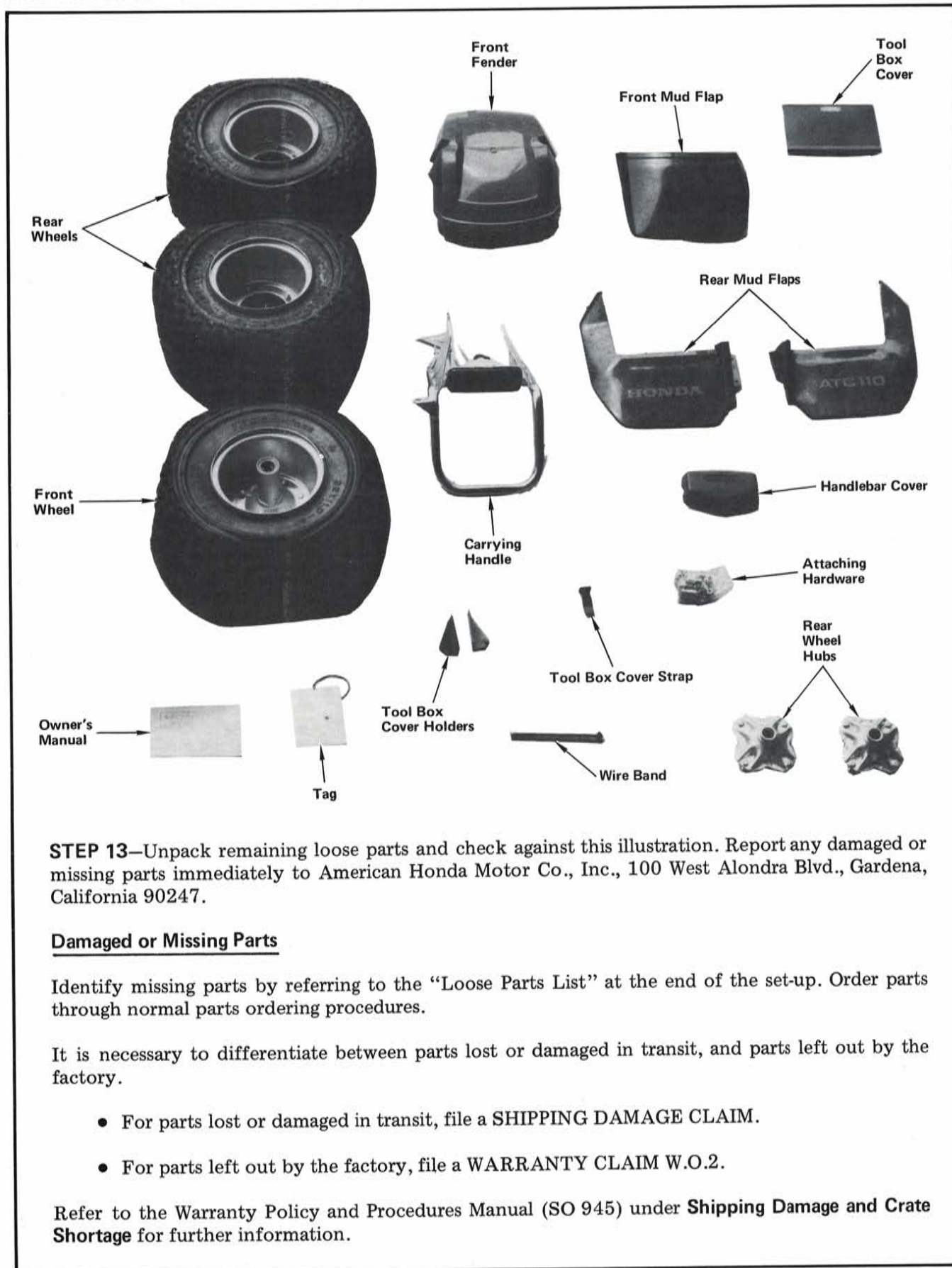

STEP 13—Unpack remaining loose parts and check against this illustration. Report any damaged or missing parts immediately to American Honda Motor Co., Inc., 100 West Alondra Blvd., Gardena, California 90247.

Damaged or Missing Parts

Identify missing parts by referring to the "Loose Parts List" at the end of the set-up. Order parts through normal parts ordering procedures.

It is necessary to differentiate between parts lost or damaged in transit, and parts left out by the factory.

- For parts lost or damaged in transit, file a **SHIPPING DAMAGE CLAIM**.
- For parts left out by the factory, file a **WARRANTY CLAIM W.O.2**.

Refer to the Warranty Policy and Procedures Manual (SO 945) under **Shipping Damage and Crate Shortage** for further information.

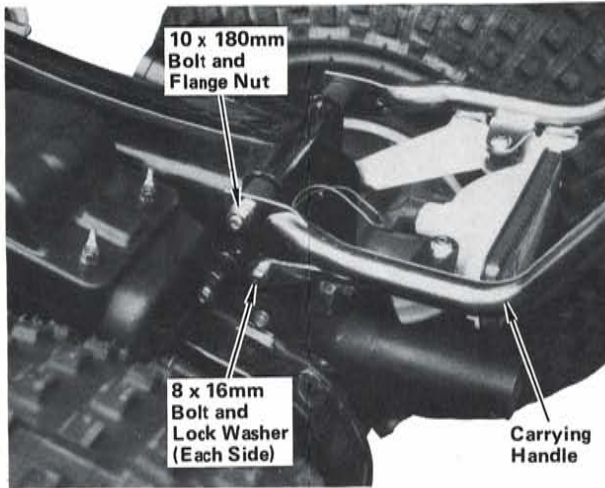

STEP 14—Position carrying handle with curve up as shown and reinstall using a 10 x 180 mm bolt and flange nut and two 8 x 16 mm bolts and lock washers. Tighten bolts to specified torque. Check that taillight wires are still connected color-to-color.

Torque specifications:

- 8 mm bolts: 2.2 kg-m (16 lb-ft)
- 10 mm nut: 4.4 kg-m (32 lb-ft)

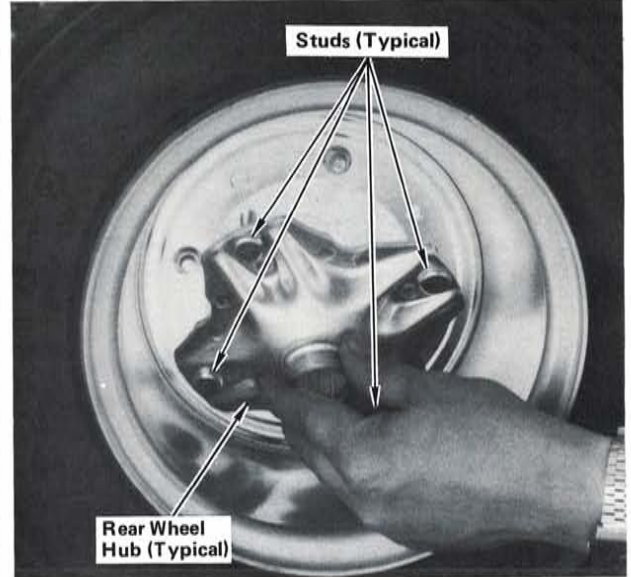

STEP 15—Insert studs of rear wheel hubs through rear wheels from side opposite valve stem.

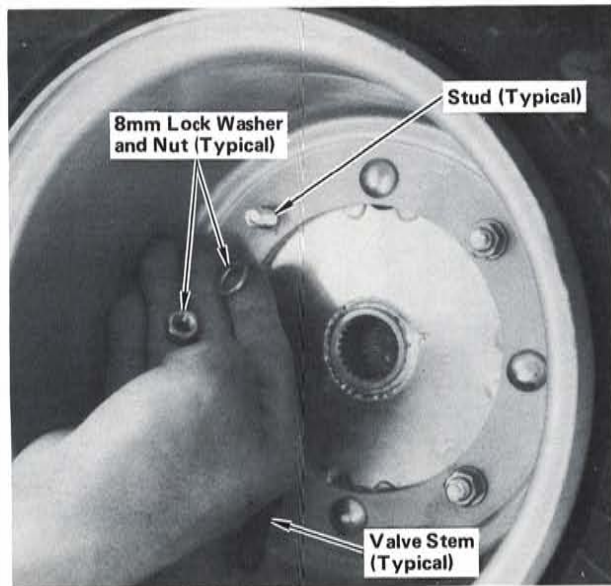

STEP 16—Install each rear wheel hub using four 8 mm lock washers and nuts on side of wheel having valve stem. Repeat step for other wheel. Tighten nuts to specified torque.

Torque specification:

- 2.2 kg-m (16 lb-ft)

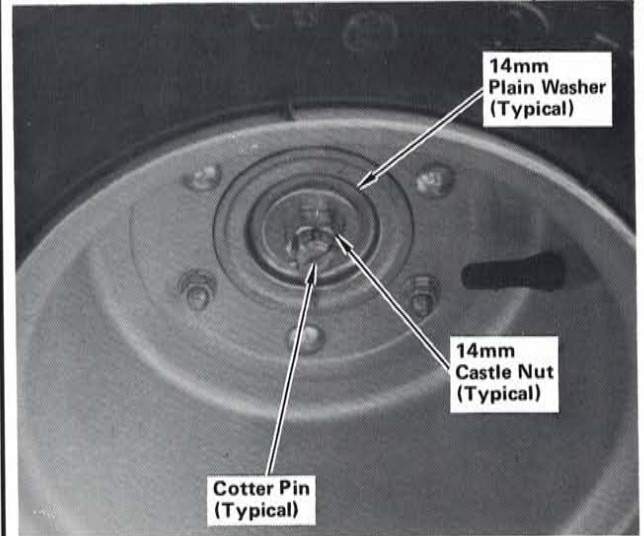

STEP 17—Grease axle splines and install rear wheels, with valve stems to the outside, using a 14 mm plain washer and castle nut for each. Tighten both rear axle nuts to specified torque and install a cotter pin in each. Spread ends of cotter pin as shown.

Torque specification:

- 7 kg-m (51 lb-ft)

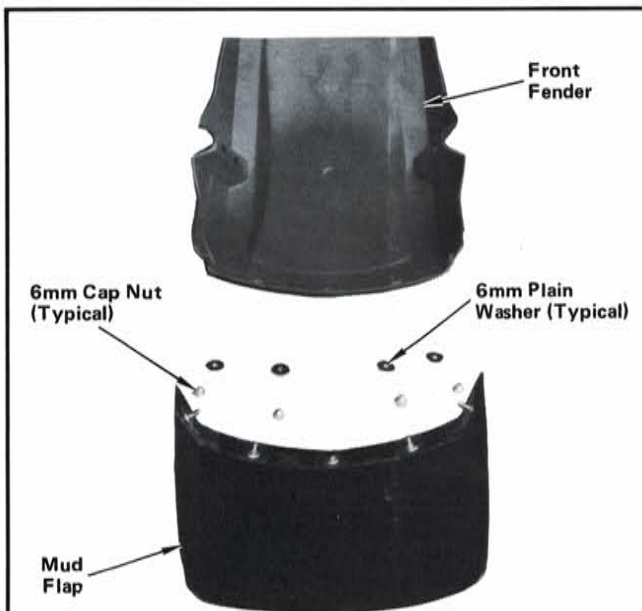

STEP 18—Install front fender mud flap using four 6 mm plain washers and cap nuts. Tighten nuts securely.

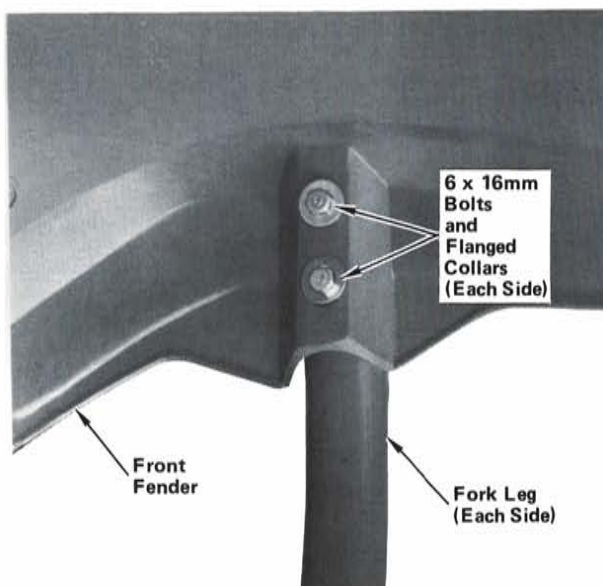

STEP 19—Install front fender between fork legs as shown and install using four 6 x 16 mm bolts and flanged collars. Tighten bolts to specified torque.

Torque specification:
1.0 kg-m (8 lb-ft)

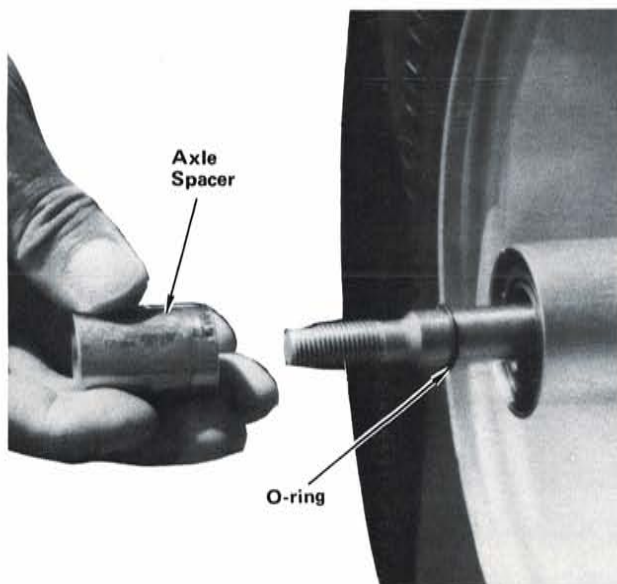

STEP 20—Remove front axle from fork legs. Insert front axle in front wheel hub. Grease front wheel hub seals, and slip an O-ring and spacer over each end of front axle and push into seal.

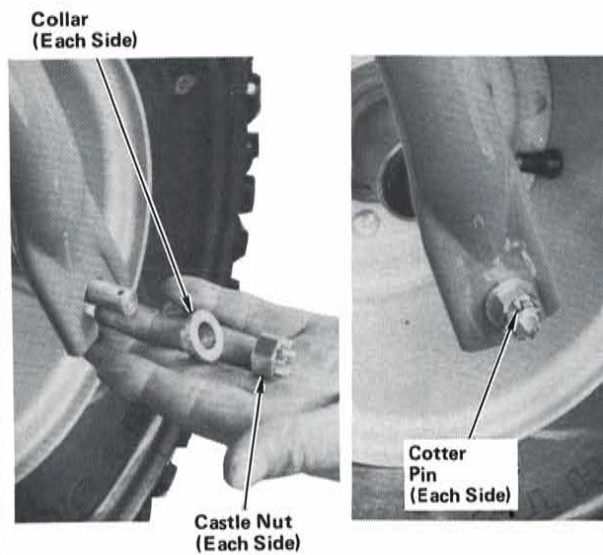

STEP 21—Install front wheel, using two collars and castle nuts. Tighten both axle nuts to specified torque and install a cotter pin in each. Spread ends of cotter pins as shown.

Torque specification:
7 kg-m (51 lb-ft)

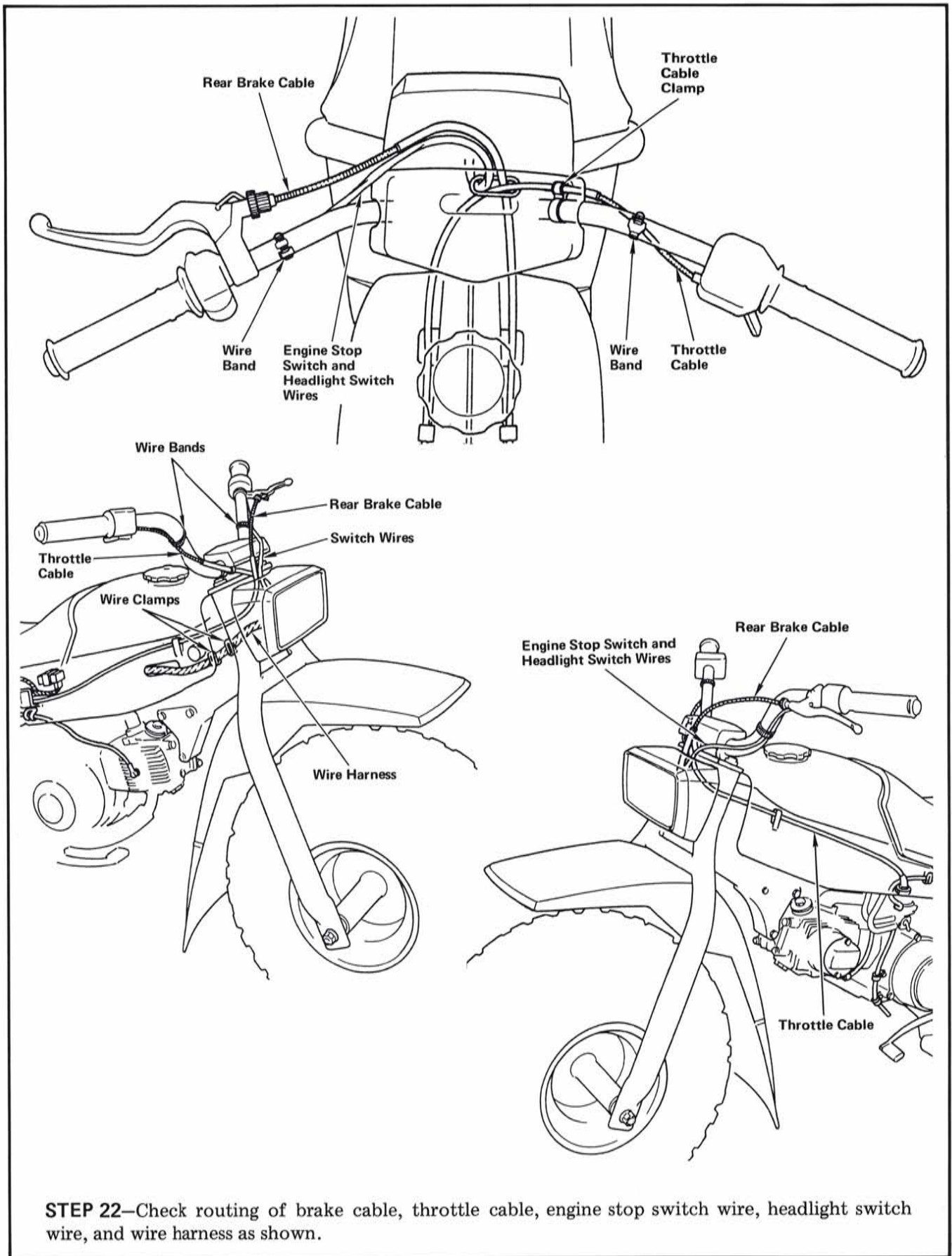

STEP 22—Check routing of brake cable, throttle cable, engine stop switch wire, headlight switch wire, and wire harness as shown.

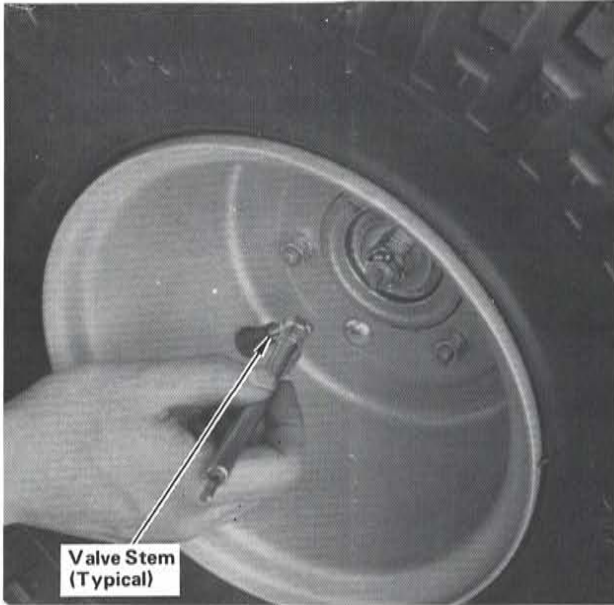

Valve Stem
(Typical)

STEP 23—Inflate all tires and check tire pressure.
All tires: 2.2 psi.



Oil Filler
Cap/Dipstick

STEP 24—Remove oil filler cap and fill crankcase with recommended oil as described in owner's manual. Reinstall and tighten cap.
NOTE: Do not drain oil until break-in period has been completed.

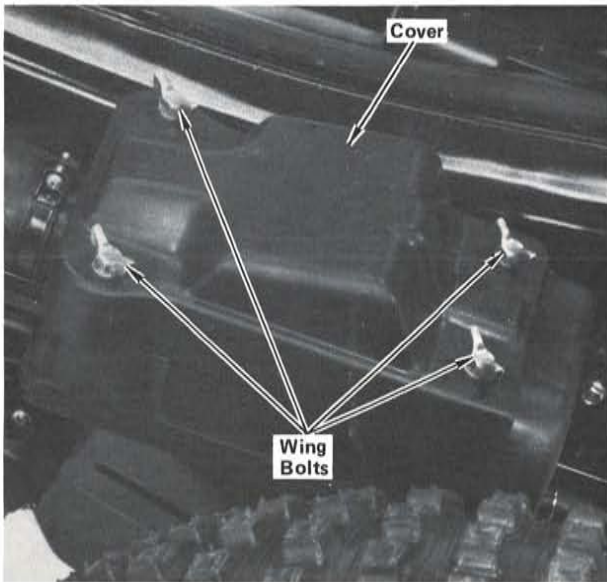

Cover

Wing
Bolts

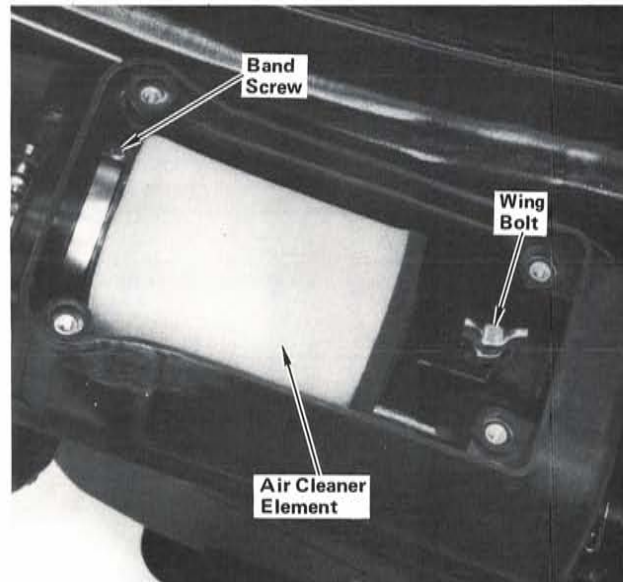

Band
Screw

Wing
Bolt

Air Cleaner
Element

STEP 25—Remove wing bolts attaching air cleaner cover and retainer. Loosen air cleaner band screw. Remove air cleaner element assembly from air cleaner case. Remove retainer from air cleaner core and remove air cleaner element. Check condition of element. If necessary, clean element as described in owner's manual or shop manual. Reinstall element, retainer, and assembly into air cleaner case. Tighten air cleaner band screw. Reinstall air cleaner cover and tighten wing bolts securely.

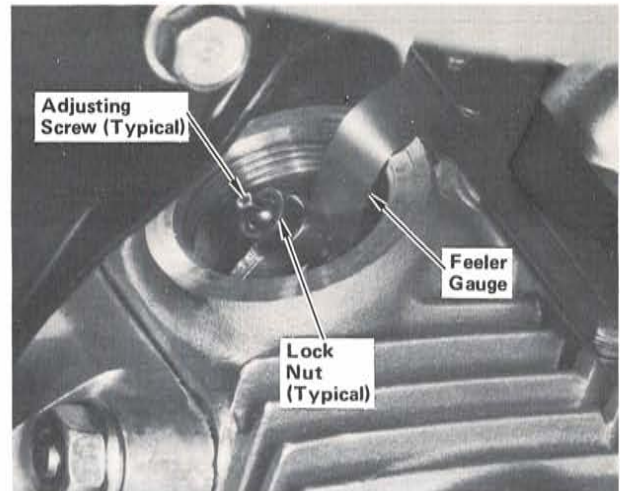

NOTE: Valve clearance adjustment must be done while engine is cold (below 35° C; 95° F).

STEP 26—Remove timing hole cap and tappet covers. Turn crankshaft counterclockwise and align “T” mark on rotor with index mark, when piston is on compression stroke. Check intake and exhaust valve clearance by inserting a feeler gauge between adjusting screw and valve stem. If adjustment is necessary, loosen lock nut and turn adjusting screw as required to obtain a slight drag on feeler gauge. After adjustment, hold adjusting screw and tighten lock nut. Recheck valve clearance. Reinstall tappet covers.

Intake and exhaust valve clearance: 0.07 mm (0.003 in.)

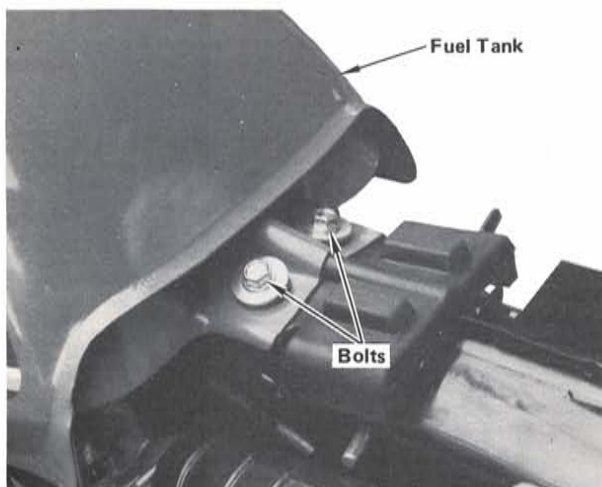

STEP 27—Drain fuel tank as described in owner's manual. Remove fuel tank by disconnecting fuel lines and removing two bolts at rear of the tank. Inspect and flush tank. Reinstall fuel tank using the two bolts removed, and connect fuel lines. Tighten bolts securely.

WARNING Fuel must be drained into a proper container. Gasoline is flammable and explosive under certain conditions. Do not smoke or allow flames or sparks near while draining fuel.

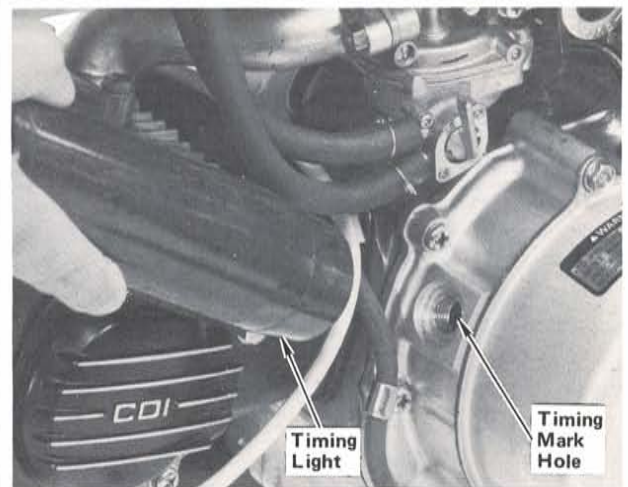

STEP 28—Connect a stroboscopic timing light and check transmission in neutral. Start engine and allow it to idle. Aim timing light at timing mark hole and check that “F” mark is aligned with index mark at idle. Reinstall timing hole cap. Removing timing light.

NOTE: The C.D.I. (Capacitor Discharge Ignition) system is factory preset and cannot be adjusted. If timing is incorrect, check C.D.I. units as described in shop manual.

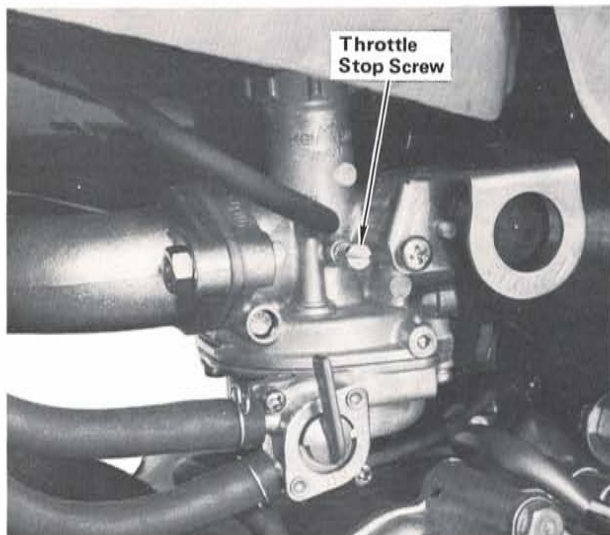

STEP 29—Connect a tachometer. Start engine and warm it up to operating temperature. Adjust idle speed to 1,700 rpm using throttle stop screw. Stop engine and disconnect the tachometer.

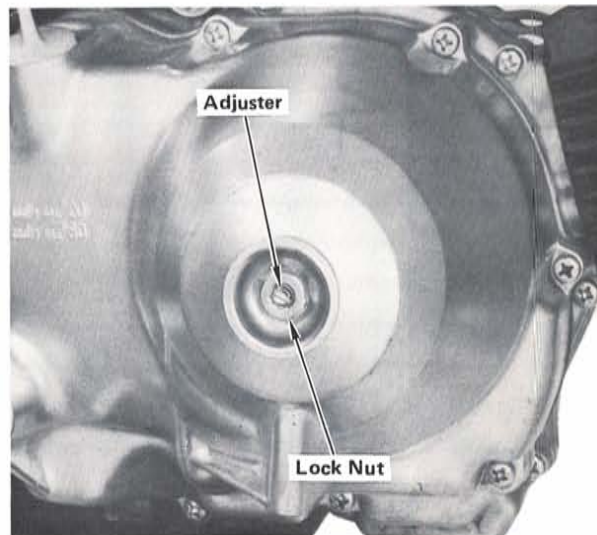

STEP 30—Check clutch operation. If adjustment is necessary, use the following procedure. Loosen lock nut and turn clutch adjuster counterclockwise until resistance is felt, then turn clutch adjuster 1/8 turn clockwise and tighten lock nut. Recheck clutch operation.

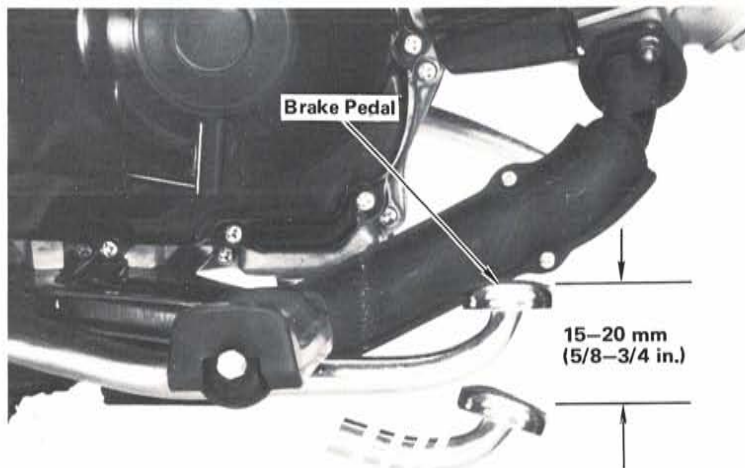

STEP 31—Check brake pedal free play. If adjustment is necessary, turn adjusting nut on brake rod at rear of frame.

Free Play: 15–20 mm (5/8–3/4 in.)

This page supersedes page 12 dated 8/82. Remove and destroy superseded page.

Rev. 10/82

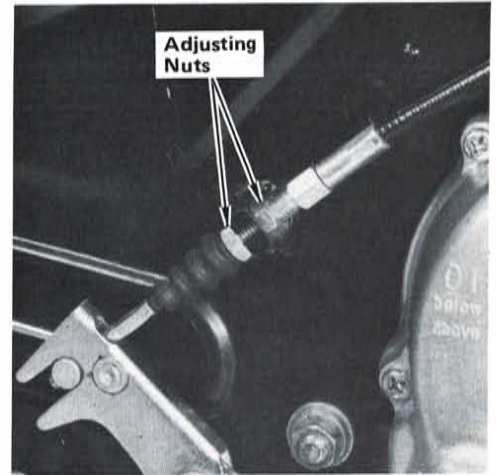
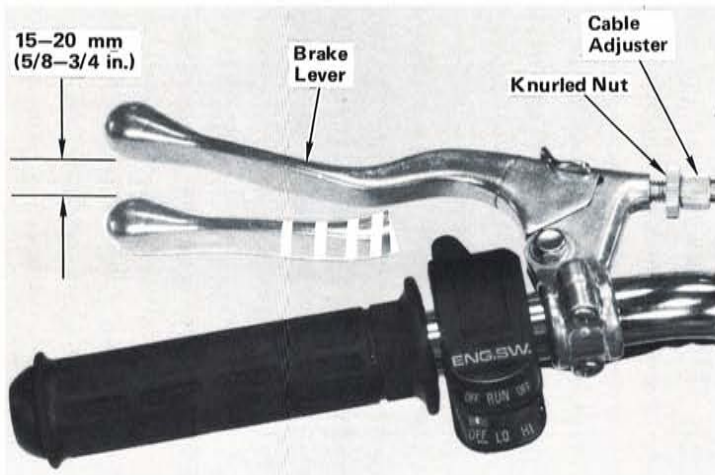

STEP 32—Place a block under ATC. Spin rear wheels by hand and measure free play of rear brake hand lever before brake starts to engage. Free play, measured at tip of rear brake hand lever should be between 15 and 20 mm (5/8–3/4 in.). Use adjusting nuts on rear brake arm to make large adjustments. Small adjustments are made at rear brake hand lever by loosening knurled nut and turning cable adjuster. After adjustment, tighten knurled nut. Remove block from under ATC.

Free Play: 15–20 mm (5/8–3/4 in.)

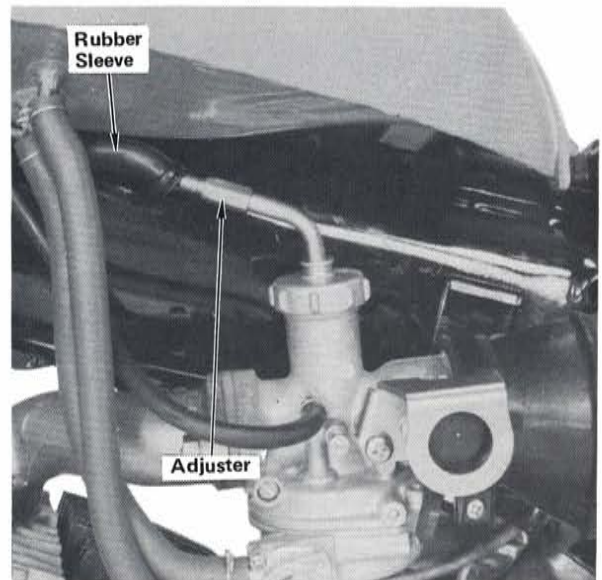
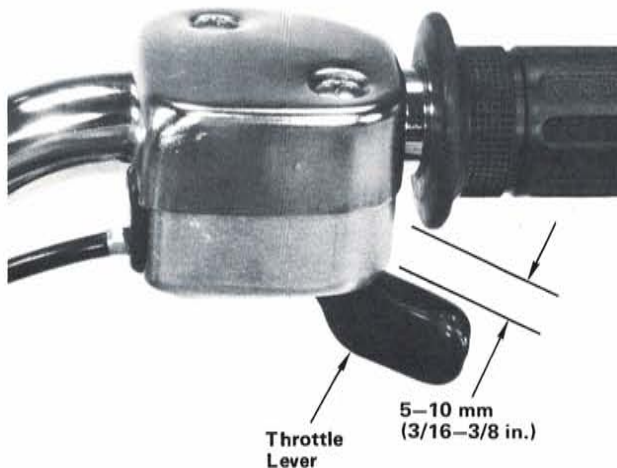

STEP 33—Check throttle lever free play. If adjustment is necessary, slide rubber sleeve on carburetor forward and turn throttle cable adjuster as necessary. Slide rubber sleeve back over adjuster.

Throttle lever free play: 5–10 mm (3/16–3/8 in.)

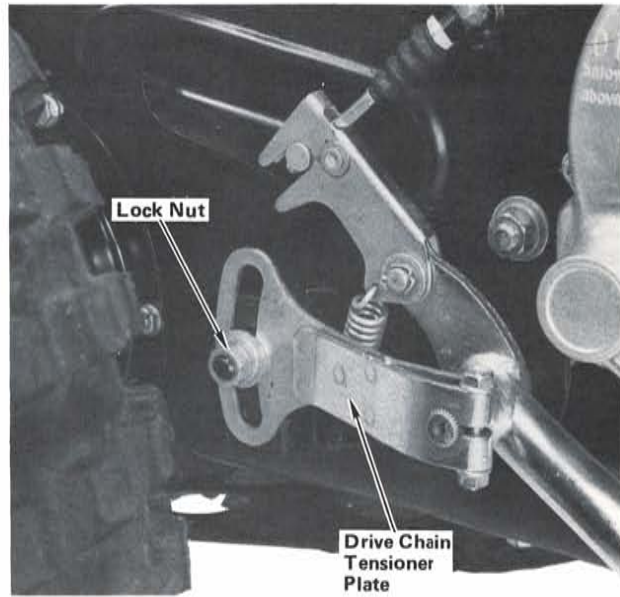
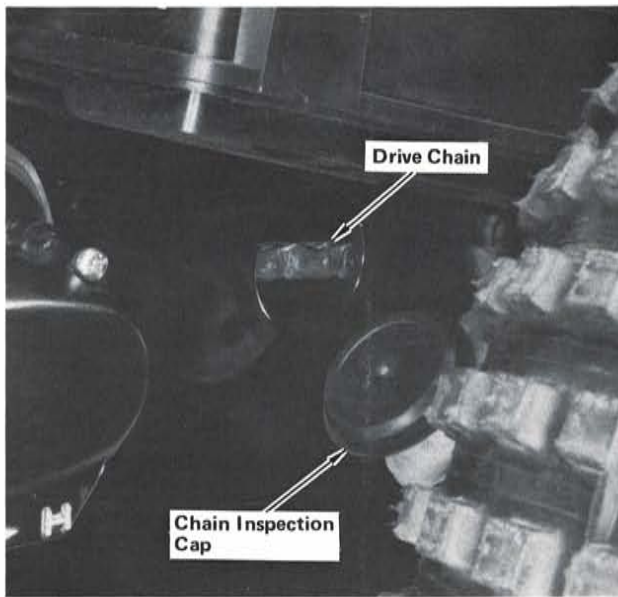

STEP 34—Remove drive chain inspection cap and check chain slack. If adjustment is necessary, loosen lock nut and move chain tensioner plate as required to obtain correct slack. After adjustment, tighten lock nut and recheck chain slack. Lubricate drive chain and reinstall chain inspection cap.

Drive chain slack: 10–20 mm (3/8–3/4 in.)

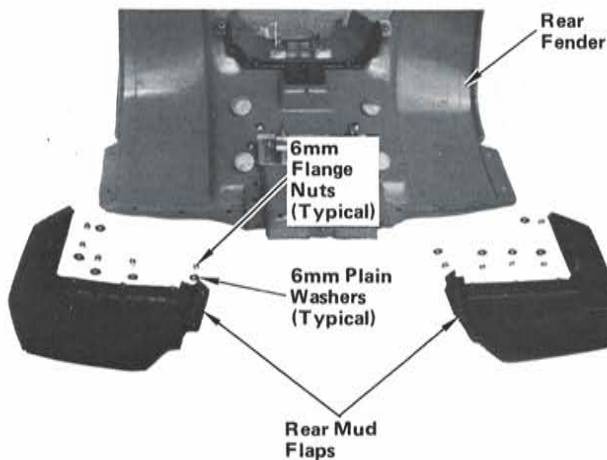

STEP 35—Install right and left rear mud flaps on rear fender by inserting studs on mud flaps down through fender with 6 mm plain washers and flange nuts under fender. Tighten nuts securely.

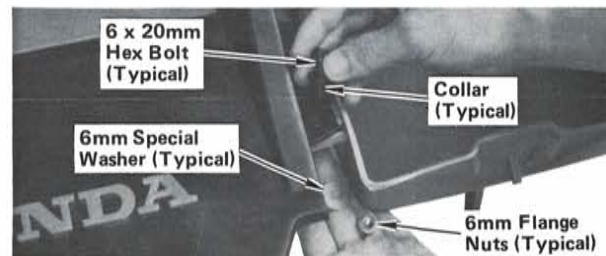
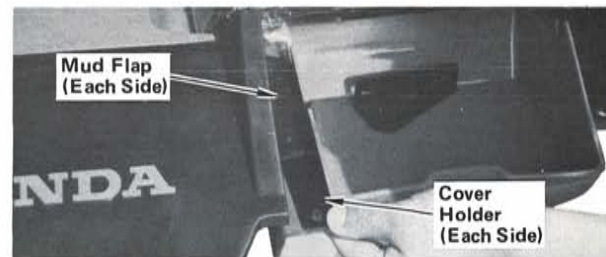

STEP 36—Position tool box cover holders (one on each side) between mud flap and rear fender and align the holes. Install holders using four 6 x 20 mm black hex bolts and collars down through holes, and four 6 mm special washers and flange nuts under fender. Tighten nuts securely.

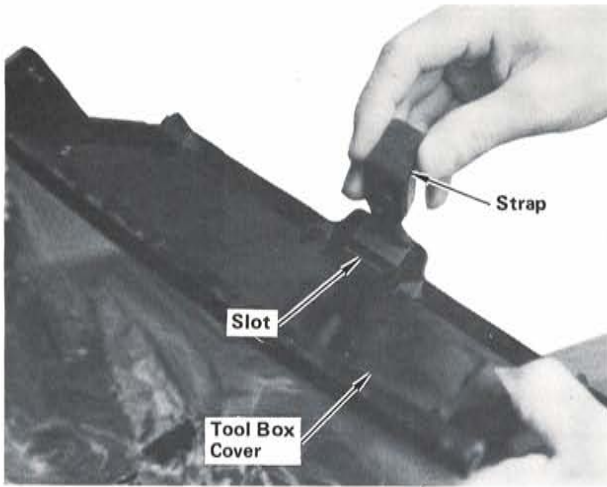

STEP 37—Install tool box cover strap as shown by coating end of rubber with soapy water and inserting end into slot in tool box cover.

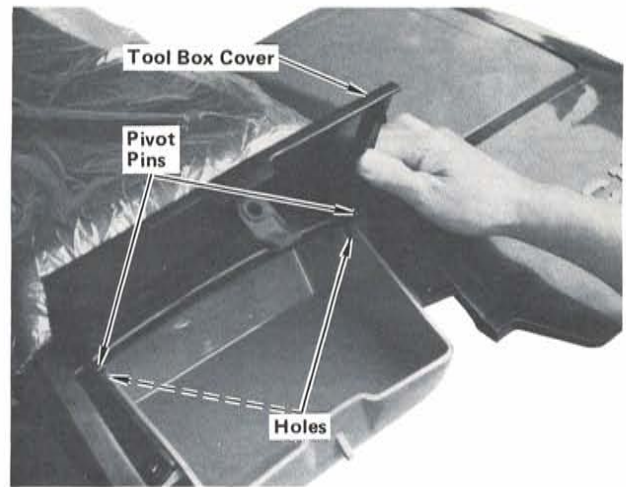

STEP 38—Snap tool box cover pivot pins into holes of cover holders as shown.

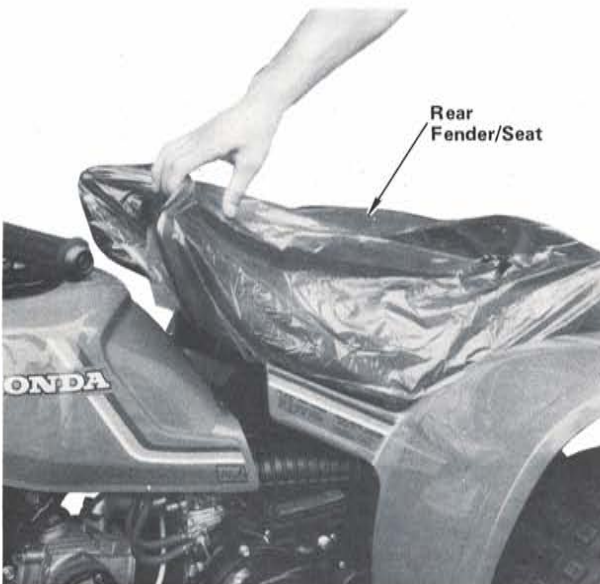

STEP 39—Install and latch rear fender/seat.



STEP 40—Hang speed limiter tag onto handlebar.

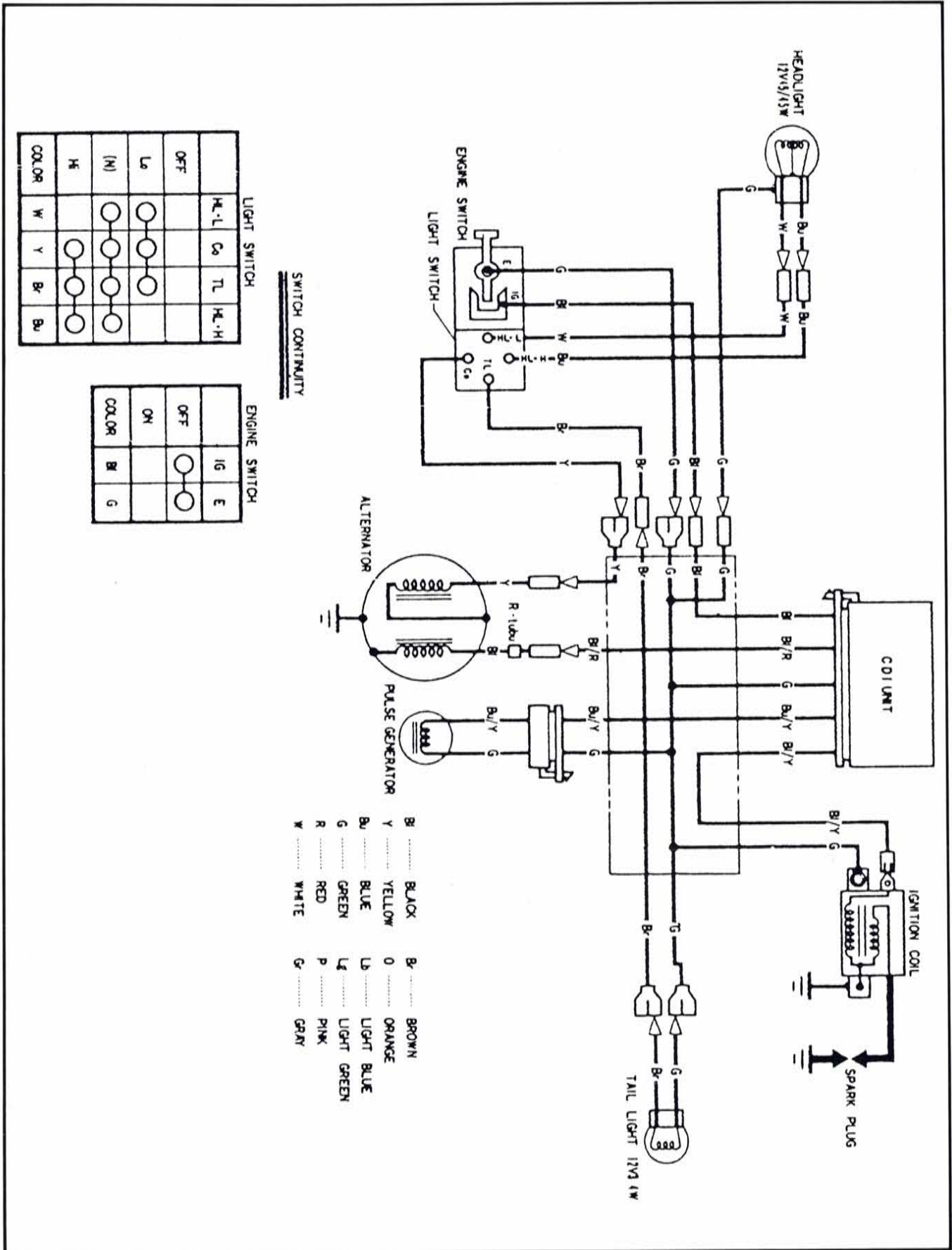

TORQUE TABLE

ITEM	SIZE	TORQUE
Front fork bolts	-----	6.0 kg-m (44 lb-ft)
Handlebar holder bolts		2.4 kg-m (18 lb-ft)
Carrying handle bolts	8 x 16 mm	2.2 kg-m (16 lb-ft)
	10 x 180 mm	4.4 kg-m (32 lb-ft)
Rear wheel flange nuts	8 mm	2.2 kg-m (16 lb-ft)
Rear axle nuts	14 mm	7.0 kg-m (51 lb-ft)
Front fender bolts	6 x 16 mm	1.0 kg-m (8 lb-ft)
Front axle nuts	12 mm	7.0 kg-m (51 lb-ft)

NOTE: Check all items listed on the following Pre-delivery Service Check List. Refer to owner's manual for specifications and detailed procedures. Always test ride the unit to make sure that it is functioning properly.

PRE-DELIVERY SERVICE CHECK LIST

- | | |
|--|--|
| <ul style="list-style-type: none"> <input type="checkbox"/> Adjust rear brake, check cable routing and check operation. <input type="checkbox"/> Fill crankcase with recommended oil. <input type="checkbox"/> Remove and inspect fuel tank, drain and flush. <input type="checkbox"/> Check valve clearance; adjust if necessary. <input type="checkbox"/> Reinstall fuel tank, fill, turn on petcock, and check for leaks. <input type="checkbox"/> Check ignition timing. <input type="checkbox"/> Adjust idle speed. <input type="checkbox"/> Check throttle lever free play, cable routing, and operation in all steering positions. <input type="checkbox"/> Adjust and lubricate drive chain. <input type="checkbox"/> Check tire pressure. | <ul style="list-style-type: none"> <input type="checkbox"/> Inspect electrical components for proper operation and adjustment. <ul style="list-style-type: none"> • Headlight switch. • Headlight: Adjust high and low beam aim. • Taillight. • Engine stop switch. <input type="checkbox"/> Check security of all nuts, bolts, and other fasteners. <input type="checkbox"/> Check to ensure that all applicable recall and product update campaigns are complied with. <input type="checkbox"/> TEST RIDE: Check performance, handling, and operation. <ul style="list-style-type: none"> • Transmission: high-low gear range selector, and clutch: Ease of shifting, clutch operation, etc. • Acceleration: Smoothness, etc. • Cruising: Smoothness, etc. • Handling: Stability and cornering. • Brakes: Smoothness and stopping power. • Idling: Smoothness, throttle response, and return to idle. • Recheck idle speed after 10 minutes of stop and go operation. • Upon completion of test ride, check for fuel and oil leaks. |
|--|--|

LOOSE PARTS LIST

The following is a list of items contained in the parts carton and loose parts in the crate.

DESCRIPTION	QTY	H/C	PART NUMBER
Front fender	1	130434	61110-943-003ZA
		130343	61110-943-003ZB
6 x 20 mm washer	4	019149	90512-300-000
6 x 16 mm hex bolt	4	062380	92000-06016-0H
Front mud guard	1	128584	61111-943-003
6 mm cap nut	5	020362	94031-06000-0S
6 mm plain washer	5	-----	94014-06800-0H
Rear fender assy	1	128590	80100-943-023ZA
	1	128591	80100-943-023ZB
Right rear fender	1	128597	80251-943-003
Left rear fender	1	128598	80256-943-003
6 x 20 mm hex bolt	4	130448	92000-06020-0G
Rear mud guard collar	4	130439	80117-943-000
6 mm plain washer	14	-----	94104-06800
Right rear mud guard	1	128594	80111-943-003
Left rear mud guard	1	1285985	80116-943-003
6 mm flange nut	14	061268	94050-06080
Carry pipe assy	1	-----	-----
10 x 180 mm hex bolt	1	026307	90196-918-000
10 mm flange nut	1	096662	94050-10800
8 x 16 mm bolt/washer	2	067726	94392-08016-08
Handle cover	1	128581	53205-943-003
Handle cover mark	1	-----	53206-958-000
6 x 20 mm screw/washer	2	-----	23891-06020-08
Front wheel assy	1	-----	-----
Front axle	1	100270	44301-958-670
Front axle collar	2	023386	44302-918-000
12 mm axle nut	2	-----	-----
Cotter pin	2	005842	94201-30250
Front axle side collar	2	-----	44312-958-670
O-Ring	2	034790	91307-611-000
Rear wheel assy	2	-----	-----
Rear wheel rim patch	2	107561	44714-958-670
Rear hub comp.	2	107554	42410-958-670
8 mm hex nut	8	-----	93500-0800
14 mm washer	2	107432	42322-950-000
Castle nut 14 mm	2	023402	94011-14000-0S
Cotter pin	2	005842	94201-30250
6 mm plain washer	2	005897	94111-06000
Cap nut 6 mm	2	020362	94021-06000-0S
Tool box band	1	130440	80214-943-000
Owner's manual	1	130451	31943600

(

(

(

(

(

(

(

READ THIS READ THIS READ THIS

HONDA

MODIFICATIONS WHICH YOU HAVE MADE, OR SHOULD MAKE IN THE FUTURE, TO ANY HONDA MOTORCYCLE, SHALL BE DEEMED BY OUR COMPANY TO HAVE BEEN PERFORMED AT YOUR SOLE RISK AND RESPONSIBILITY, AND WITHOUT OUR COMPANY'S OR THE MANUFACTURER'S APPROVAL OR CONSENT, IMPLIED OR EXPRESSED. WE FURTHER DISCLAIM ANY AND ALL LIABILITY, OBLIGATION, OR RESPONSIBILITY FOR ANY DEFECTS OF MODIFIED PARTS OR OF THE MODIFIED MOTORCYCLE, AND FOR ANY CLAIMS, DEMANDS, OR CAUSES OF ACTION FOR DAMAGE TO PROPERTY OR FOR PERSONAL INJURIES RESULTING FROM THE MODIFICATION OF SAID HONDA MOTORCYCLE.

READ THIS READ THIS READ THIS

READ THIS READ THIS READ THIS