



MPD 6114 8308
AMERICAN HONDA MOTOR CO., INC.
100 WEST ALONDRA BOULEVARD, GARDENA, CALIFORNIA 90247

WARNING

WARNING

WARNING

WARNING

SET-UP AND PRE-DELIVERY SERVICE MUST BE PERFORMED BY AN AUTHORIZED HONDA MOTORCYCLE DEALER. Proper set-up and pre-delivery service is essential to rider safety and reliability of the ATC. When a customer takes delivery of his brand new ATC, he expects it to be in excellent running condition. There are few things that will cause greater customer dissatisfaction than poor preparation of a new unit. An error or oversight made by the mechanic assembling and servicing a new unit can easily result in faulty operation, damage to the machine, or even injury to the rider.

THIS ISSUE OF THE ATC70 SET-UP INSTRUCTIONS REPLACES THE 1982, 1983 MODELS ATC70 SET-UP INSTRUCTIONS DATED 8/82. REMOVE AND DESTROY SUPERSEDED SET-UP INSTRUCTIONS.

1984 MODEL SHOWN; 1983 MODEL SIMILAR



- NOTES:**
- All steps apply to the 1983 and 1984 Models unless otherwise noted.
 - Right and left are determined from the rider's view.

SET-UP INSTRUCTION REVISED PAGES

Pages Affected

Orig. Issue Date

Rev. Date

1 through 18

8/83

Original

Remove and destroy superseded pages.

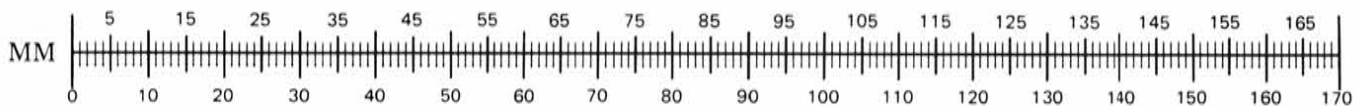

METRIC SCALE FOR DETERMINING BOLT LENGTHS/DIAMETERS

Pay special attention to warnings, cautions, and notes.

WARNING means hazards or unsafe practices which could cause severe personal injury or death.

CAUTION: means hazards or unsafe practices which could cause minor personal injury or product or property damage.

NOTE: gives helpful information.

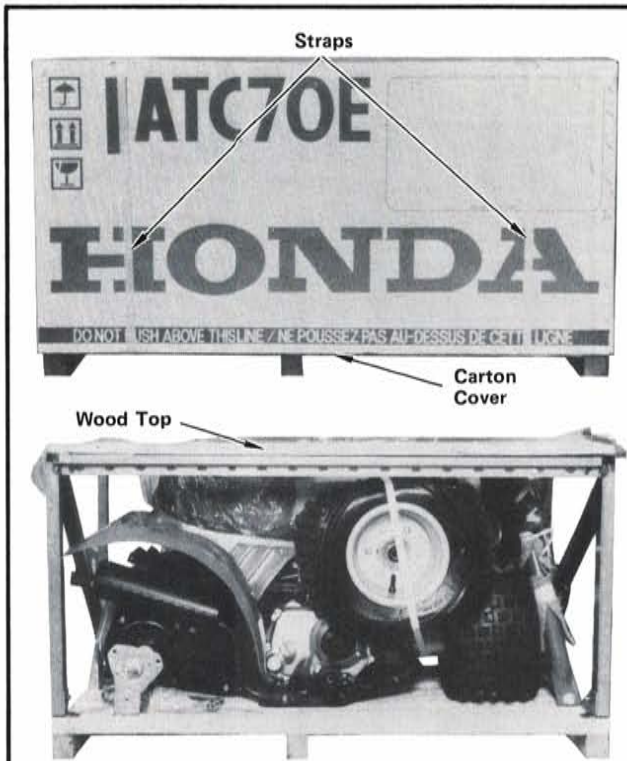

STEP 1—Cut straps and carefully lift off carton cover. Remove crate wood top.

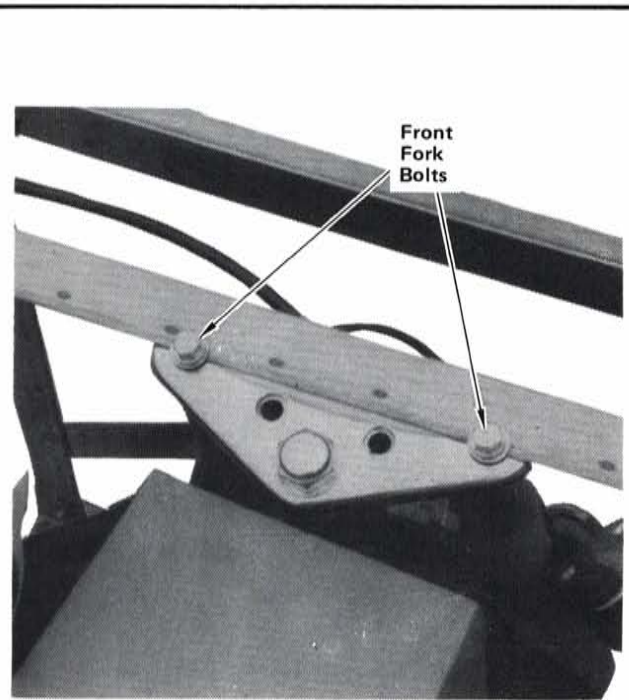

STEP 2—Loosen two front fork bolts.

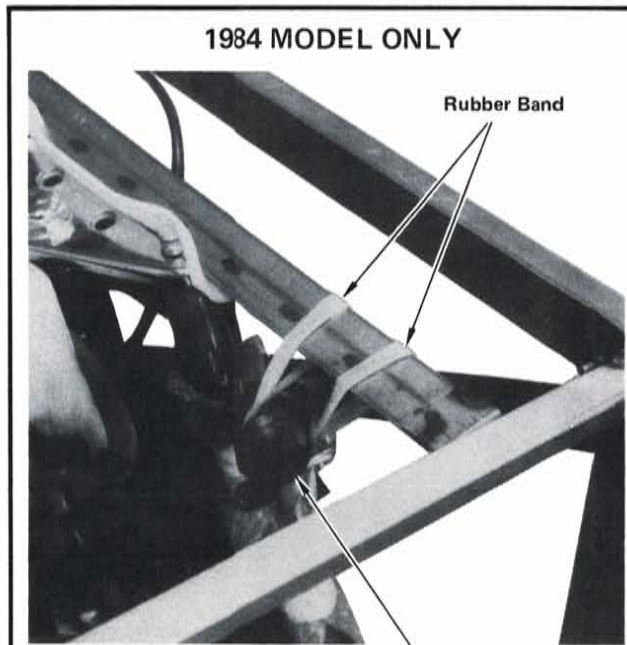

STEP 3—Remove the rubber band holding the handlebar to the crate frame.

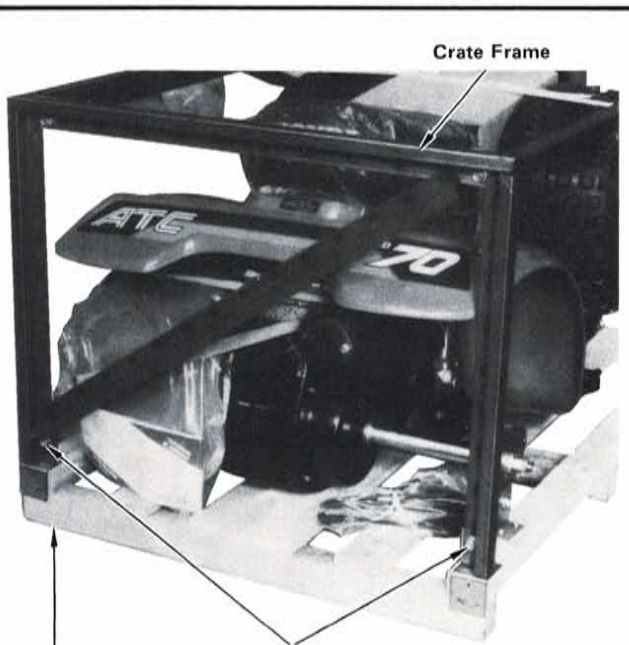

STEP 4—Remove four bolts (two on each end) attaching steel crate frame to crate base and carefully lift off crate frame.

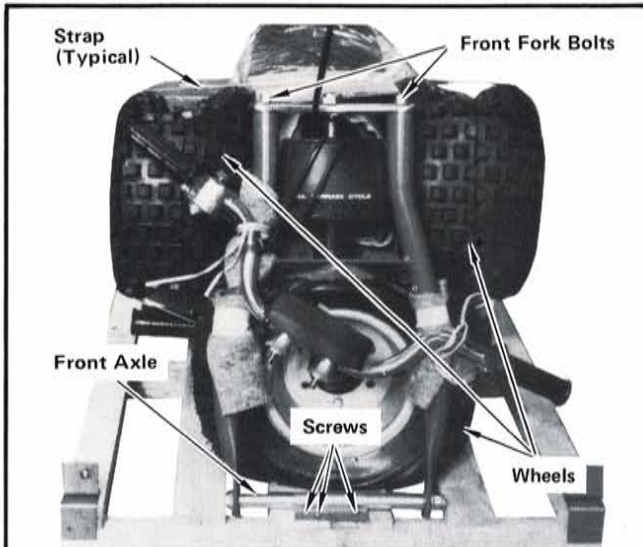

STEP 5—Cut strap holding front and rear wheels. Remove wheels. Retighten front fork bolts to specified torque.

Torque specification:
4.5 kg-m (32 lb-ft)

Remove screws attaching front axle to crate base. Discard screws. Remove rear wheel from behind front forks.

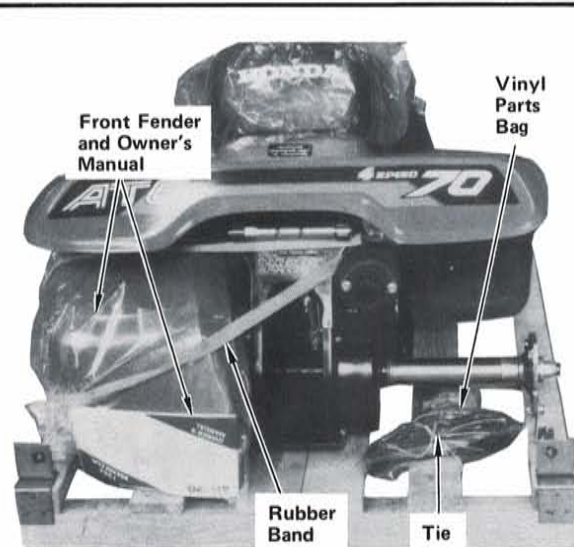

STEP 6—Remove front fender and owner's manual from crate base by removing rubber band. Remove vinyl parts bag by removing tie.

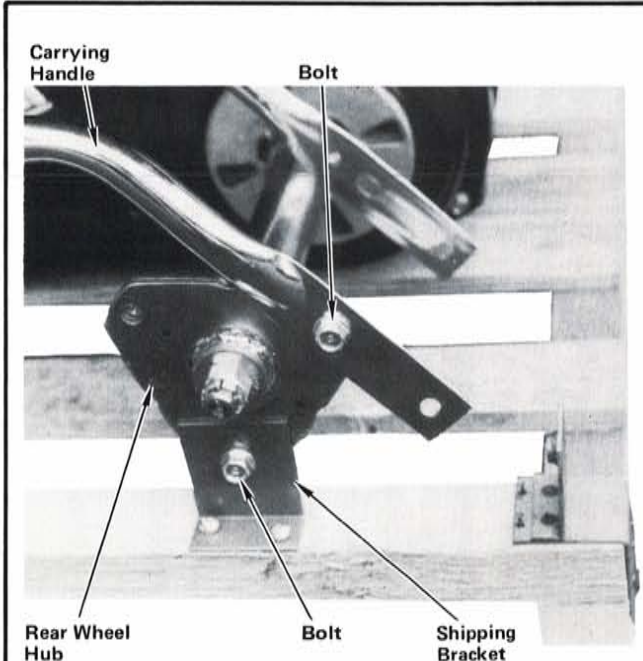

STEP 7—Remove bolt attaching carrying handle to wheel hub and remove carrying handle. Remove bolt attaching left rear wheel hub to shipping bracket. Discard bolts.

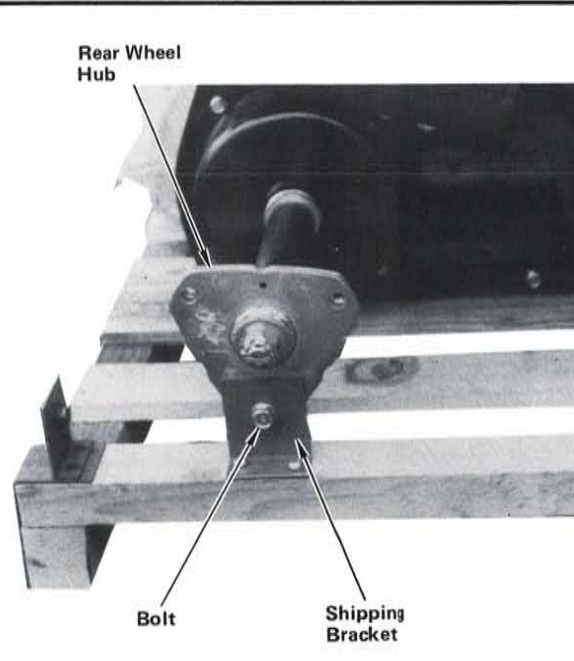

STEP 8—Remove bolt attaching right rear wheel hub to shipping bracket. Discard bolt.

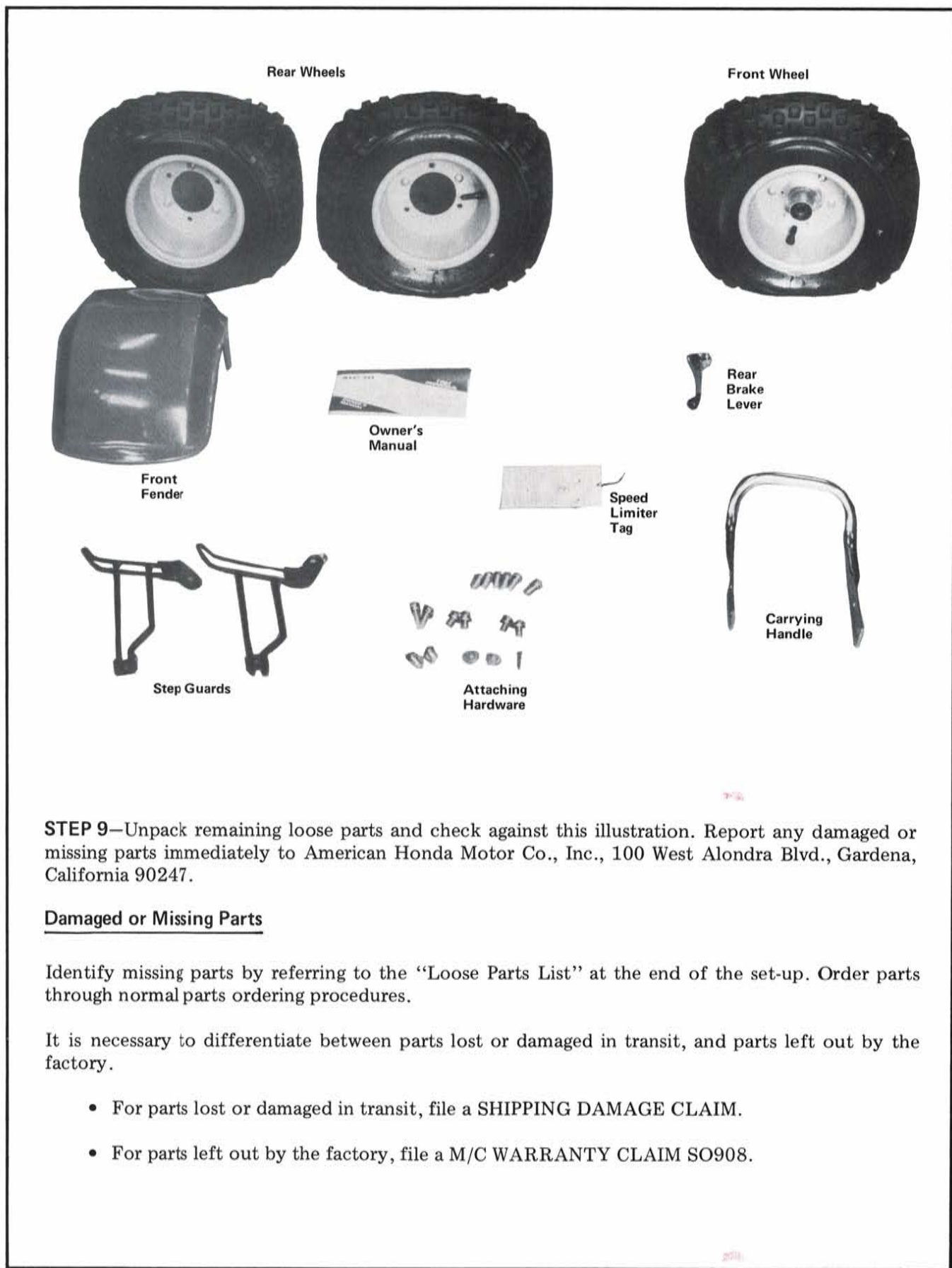

STEP 9—Unpack remaining loose parts and check against this illustration. Report any damaged or missing parts immediately to American Honda Motor Co., Inc., 100 West Alondra Blvd., Gardena, California 90247.

Damaged or Missing Parts

Identify missing parts by referring to the "Loose Parts List" at the end of the set-up. Order parts through normal parts ordering procedures.

It is necessary to differentiate between parts lost or damaged in transit, and parts left out by the factory.

- For parts lost or damaged in transit, file a SHIPPING DAMAGE CLAIM.
- For parts left out by the factory, file a M/C WARRANTY CLAIM SO908.

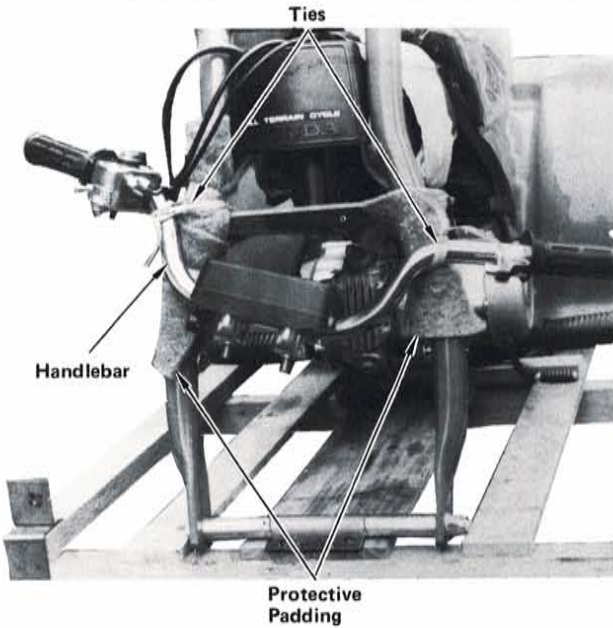

STEP 10—Remove ties holding handlebar to front fork legs. Remove protective padding from front forks.

NOTE: Do not let the handlebar hang from handlebar switch wires.

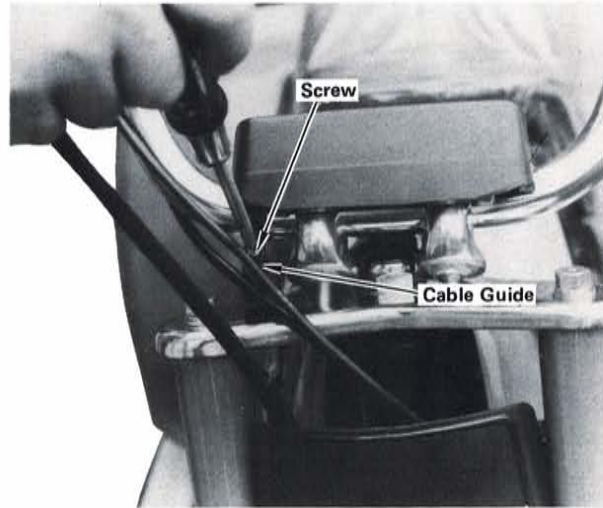

STEP 11—Push cable guide down and loosen screw.

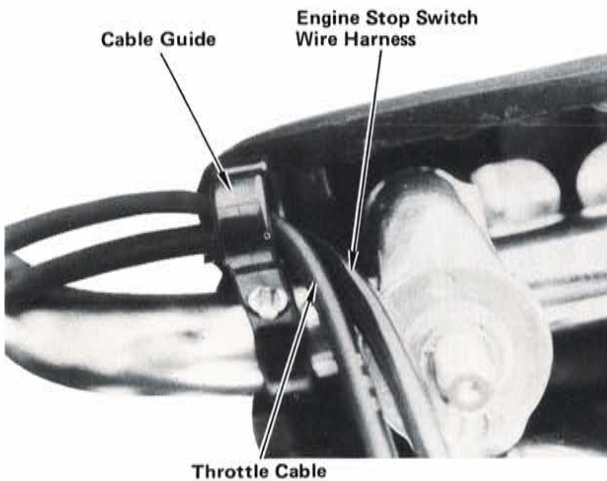

STEP 12—Route engine stop switch wire harness and throttle cable down through cable guide as shown. Tighten screw securely and push cable guide up to edge of handlebar cover.

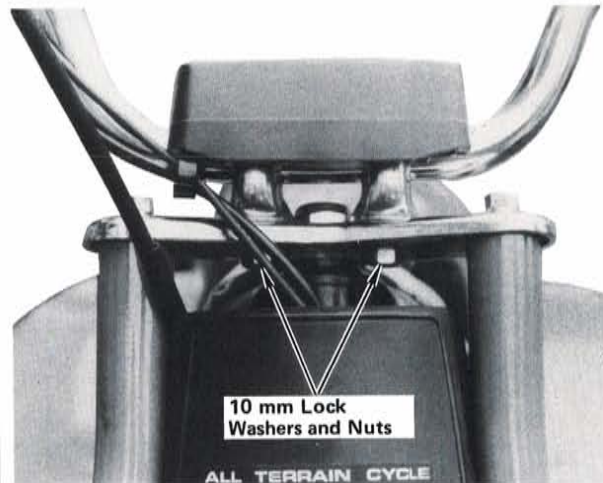

STEP 13—Install handlebar on upper fork bridge as shown using two 10 mm lock washers and nuts. Tighten nuts to specified torque.

Torque specification:
4.5 kg-m (32 lb-ft)

1984 MODEL ONLY

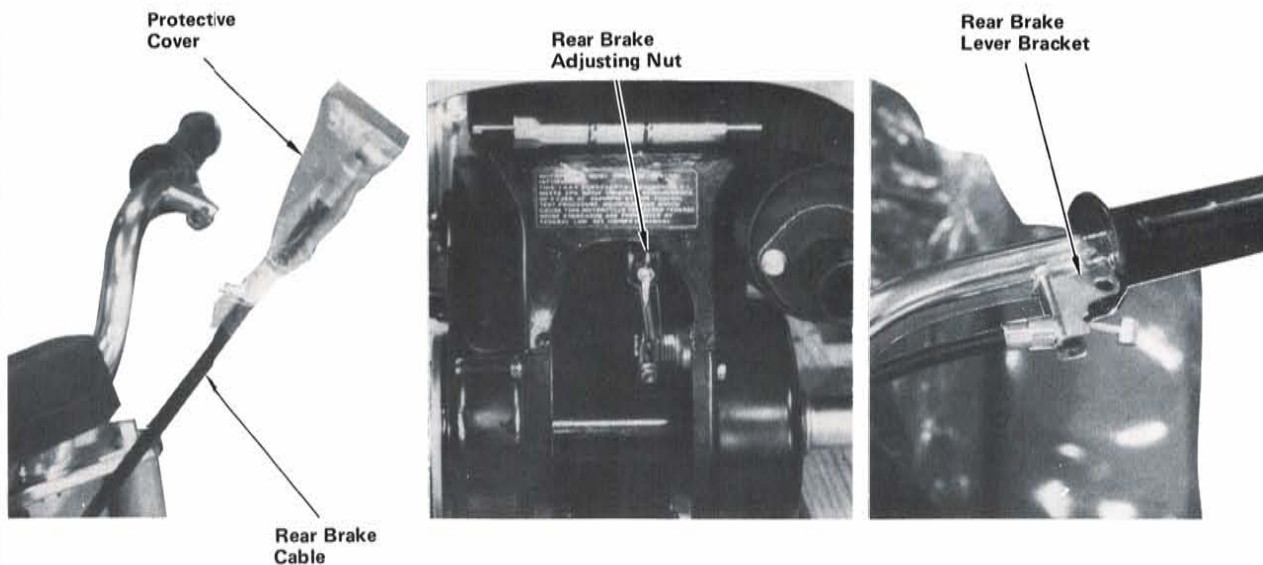

STEP 14—Remove protective cover from rear brake cable. Loosen rear brake adjusting nut on brake operating rod at rear of ATC. Route rear brake cable in front of throttle cable and insert rear brake cable into slot in rear brake lever bracket as shown.

1983 MODEL

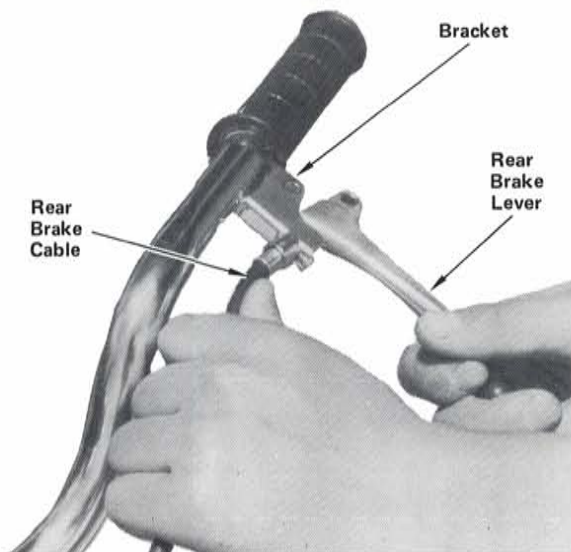

1984 MODEL

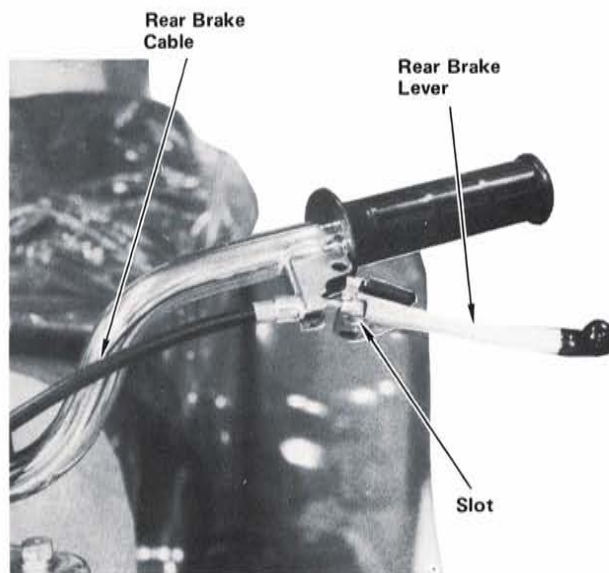

STEP 15—With the rear brake cable routed in front of throttle cable, insert end of rear brake cable into slot in brake lever.

NOTE: On 1983 models, pull cable back through slot in brake lever bracket.

1983 MODEL

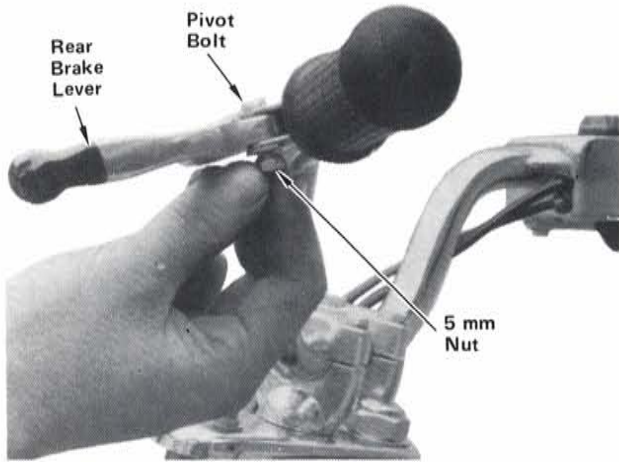

1984 MODEL

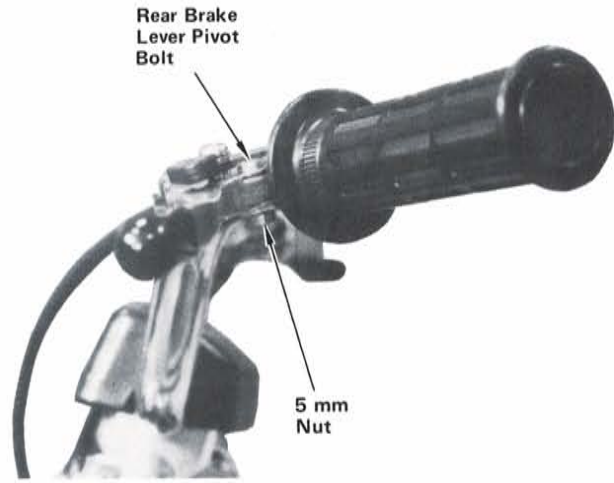

STEP 16—Install rear brake lever on bracket using a brake lever pivot bolt and 5 mm nut. Tighten nut securely.

CAUTION: Check that brake lever operates freely.

Adjust rear brake on 1983 Model as described in owner's manual or shop manual. Adjust rear brake on 1984 Model as described in Step 36.

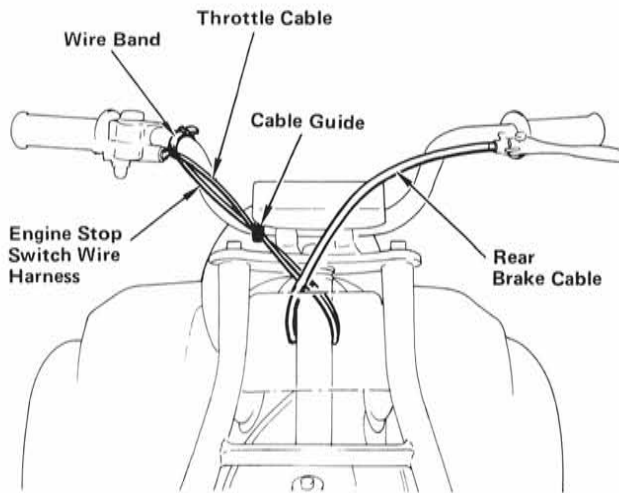

STEP 17—Check for proper routing of cables and wire harness as shown.

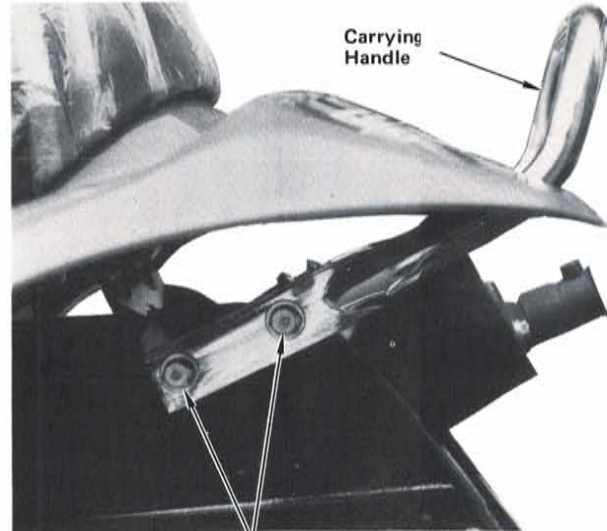

STEP 18—Install carrying handle on frame, with curved end up, using four 8 x 16 mm bolts and lock washers. Tighten bolts to specified torque.

Torque specification:
2.2 kg-m (16 lb-ft)

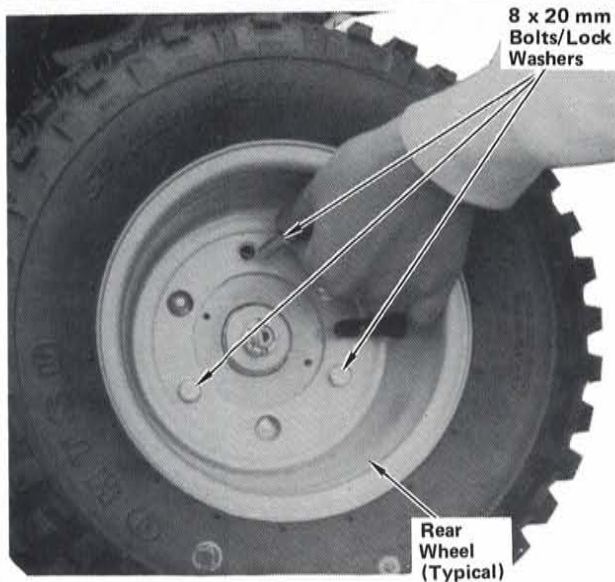

STEP 19—Inflate rear tires to 2.2 psi. Install rear wheels as shown using three 8 x 20 mm bolts/lock washers for each. Tighten bolts to specified torque.

Torque specification:
2.2 kg-m (16 lb-ft)

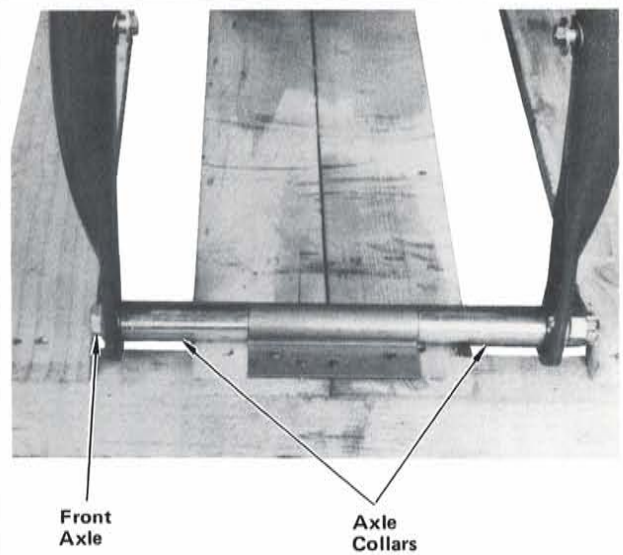

STEP 20—Remove and clean front axle and axle collars. Discard shipping bracket. Place a padded block under engine to raise front forks.

1983 MODEL ONLY

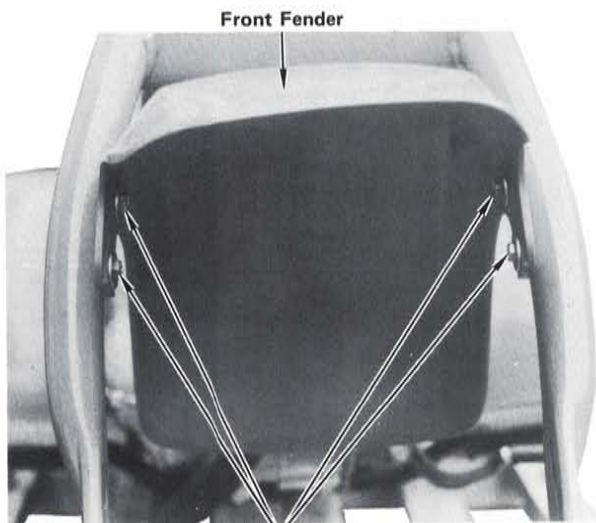

STEP 21—Remove and retain four 6 x 16 mm bolts and special washers from fork legs. Position front fender between fork legs with short end forward. Install fender using the four 6 x 16 mm bolts and special washers. Tighten bolts securely.

1984 MODEL ONLY

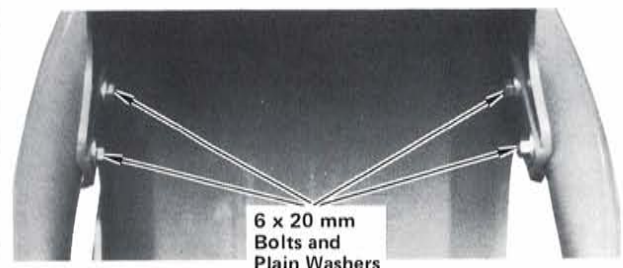
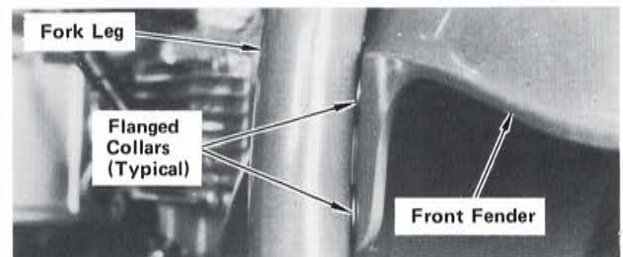

STEP 22—Remove and retain four 6 x 20 mm bolts, plain washers and flanged collars from fork legs. Position front fender between fork legs with short end forward. Install front fender using four 6 x 20 mm bolts, plain washers and flanged collars as shown. Tighten bolts securely.



STEP 23—Insert axle collars into front wheel grease seals. Inflate front tire to 2.2 psi.

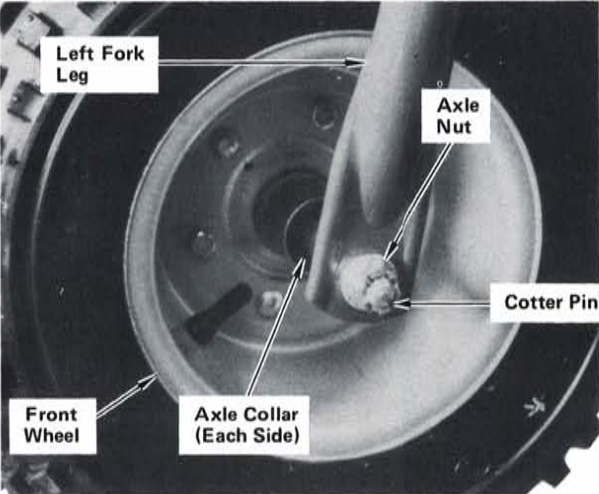

STEP 24—Position front wheel between fork legs with valve stem on left side. Insert axle from right side, through right fork leg, axle collar, wheel hub, axle collar, and left fork leg. Install axle nut and tighten nut to specified torque.

Torque specification:
7.0 kg-m (51 lb-ft)

Insert cotter pin through slots in nut and hole in axle. Spread cotter pin ends as shown.

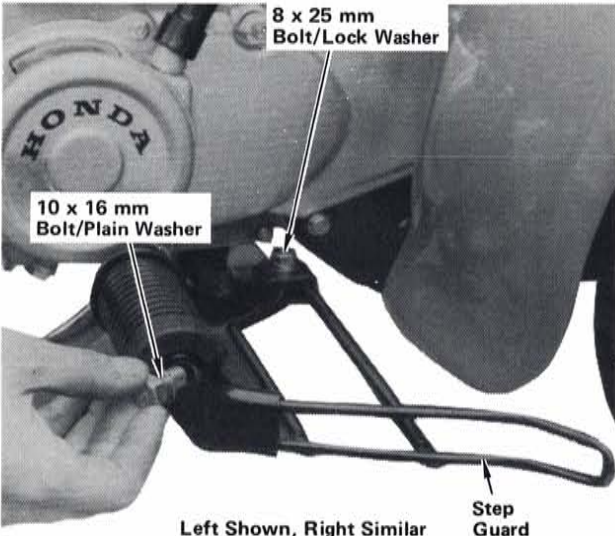

STEP 25—Install right and left step guards as shown using a 10 x 16 mm bolt/plain washer and an 8 x 25 mm bolt/lock washer for each. Tighten bolts to specified torque.

Torque specifications:
8 mm bolts: 2.2 kg-m (16 lb-ft)
10 mm bolts: 4.5 kg-m (32 lb-ft)

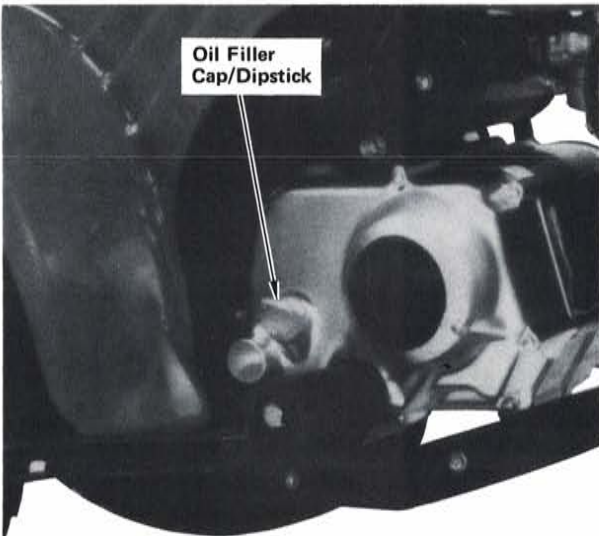

STEP 26—Remove oil filler cap/dipstick. Check engine oil level and if necessary add recommended oil as described in owner's manual or shop manual. Reinstall oil filler cap/dipstick.

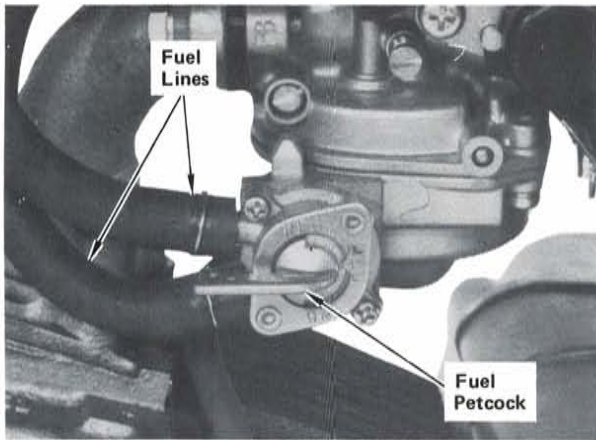

STEP 27—Inspect fuel tank. If necessary, drain and flush fuel tank by removing fuel lines. Reconnect fuel lines, fill tank, turn on fuel petcock and check for leaks. Drain residual fuel from carburetor.

WARNING

Fuel must be drained into a proper container. Gasoline is flammable and explosive under certain conditions. Do not smoke or allow flames or sparks near while draining fuel.

1983 MODEL ONLY

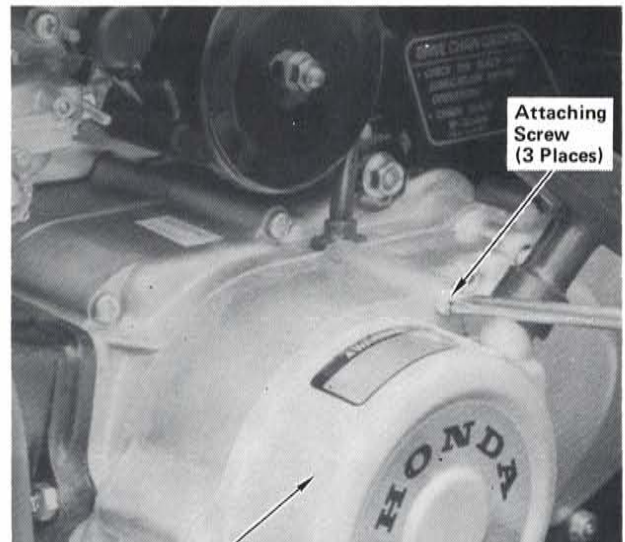

Recoil Starter

STEP 28—Remove recoil starter by removing three screws. Retain screws for reinstallation.

1983 MODEL ONLY

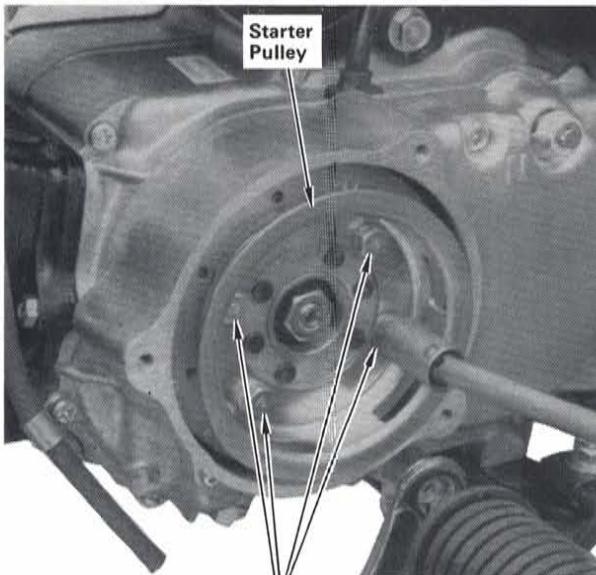

Attaching Bolts

STEP 29—Remove starter pulley by removing four 6 mm hex bolts and lock washers. Retain bolts for reinstallation.

1983 MODEL ONLY

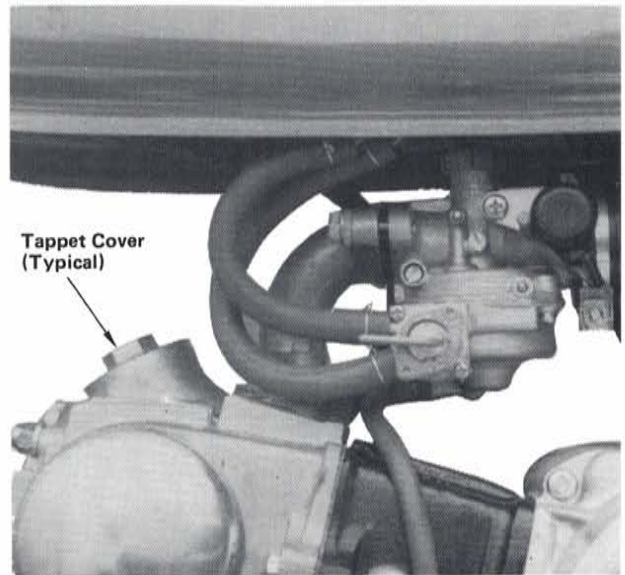

Tappet Cover (Typical)

STEP 30—Remove tappet covers.

1983 MODEL ONLY

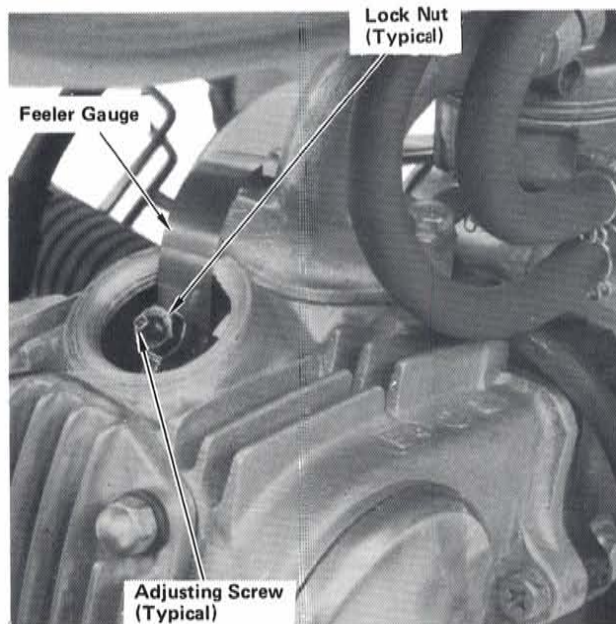
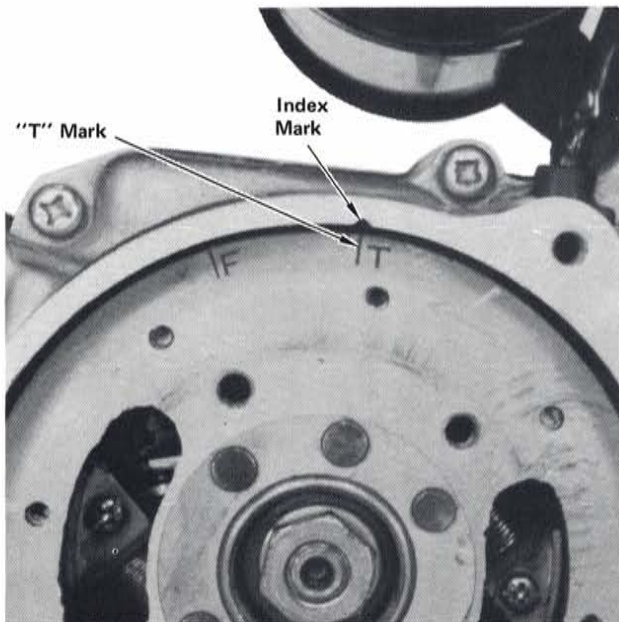

STEP 31—Turn flywheel counterclockwise to the “T” mark with piston on compression. Check valve clearance, and if necessary, adjust valve clearance as described in owner’s manual or shop manual. Reinstall tappet covers.

Intake and exhaust valves: 0.05 mm (0.002 in.)

1983 MODEL ONLY

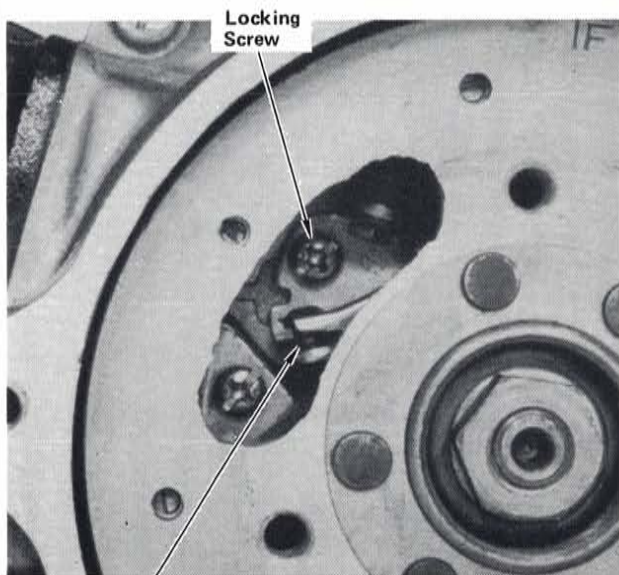

Contact Points

STEP 32—Check point gap. Adjust if necessary, as described in owner’s manual or shop manual.

Point gap: 0.3–0.4 mm (0.012–0.016 in.)

1983 MODEL ONLY

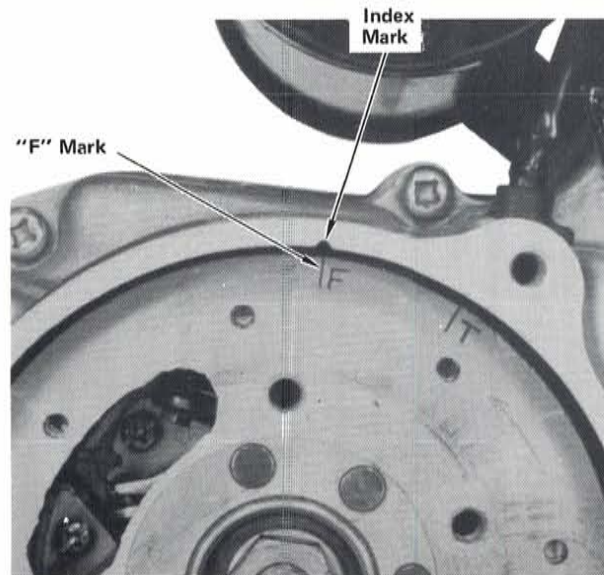

STEP 33—Turn flywheel counterclockwise to the “F” mark. Check that points are just beginning to open. Adjust if necessary, as described in owner’s manual.

1983 MODEL ONLY

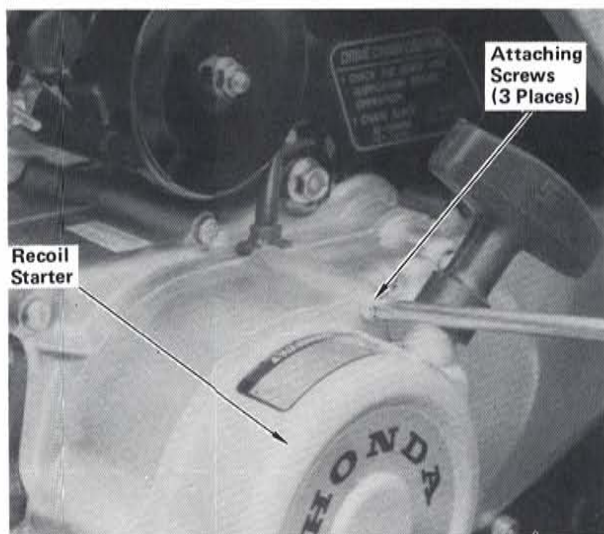

STEP 34—Reinstall starter pulley (four 6 mm hex bolts and lock washers) and recoil starter (three pan head screws). Tighten starter pulley bolts to specified torque. Tighten screws securely.

Torque specification:
1.0 kg-m (8 lb-ft)

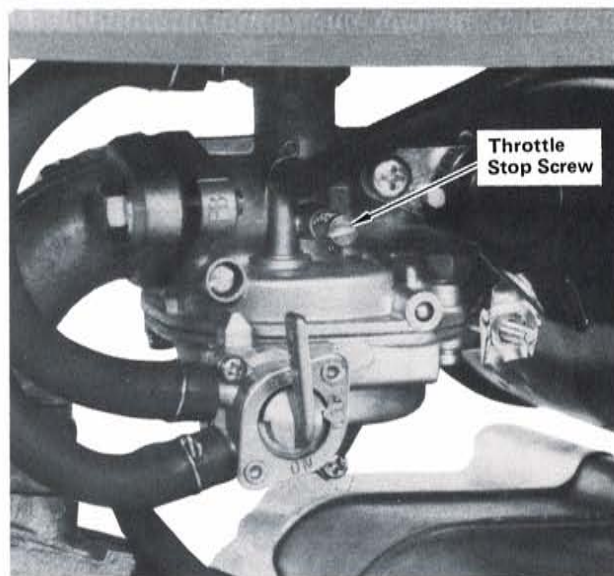

STEP 35—Adjust throttle stop screw and the throttle lever free play, if necessary, as described in owner's manual or shop manual. Refer to owner's manual for use of the speed limiter screw.

1984 MODEL ONLY

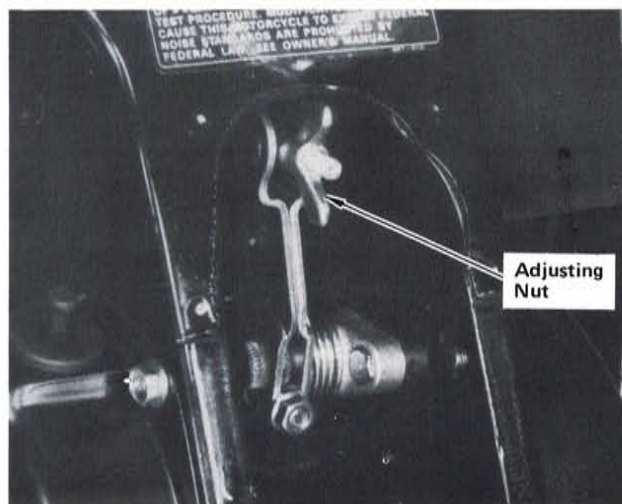
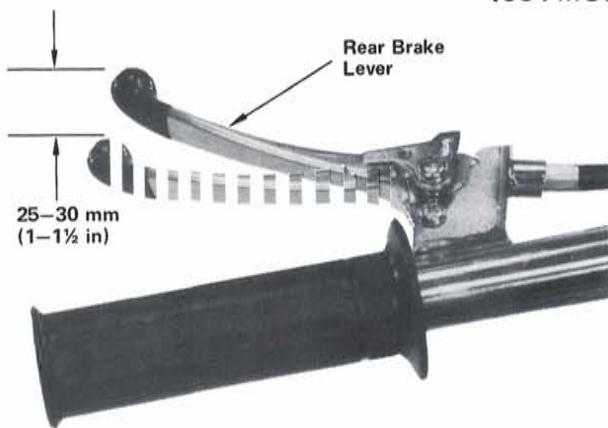

STEP 36—Place a block under ATC. Spin rear wheels by hand and measure free play of rear brake lever before brake starts to engage. Free play, measured at tip of rear brake lever, should be between 25-30 mm (1-1/2 in). Use adjusting nut on brake operating rod at rear of ATC to make adjustment. Remove block from ATC.

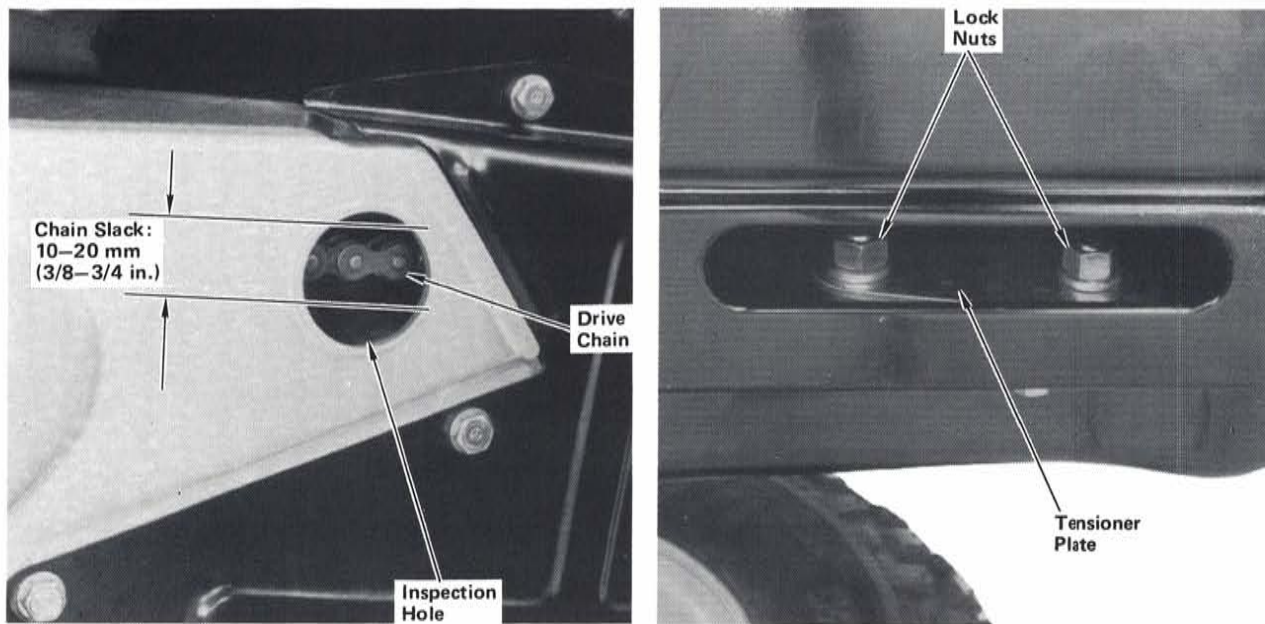

STEP 37—Remove drive chain inspection hole cover and check for a drive chain slack of 10–20 mm (3/8–3/4 in.). Adjust drive chain slack as follows, if necessary. Stop engine and position vehicle to obtain access to chain tensioner plate through hole in skid plate. Loosen the two lock nuts and move tensioner plate to obtain correct chain slack. Tighten bolt lock nuts securely. Reinstall inspection hole cover.

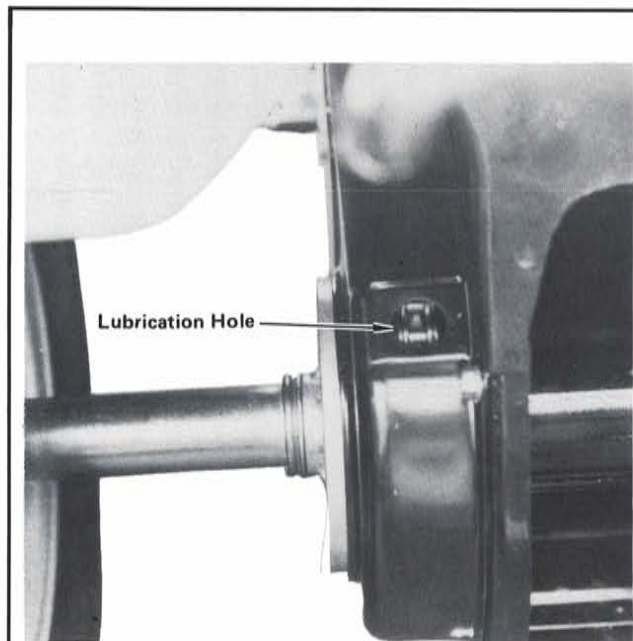

STEP 38—Remove lubrication hole cover and lubricate drive chain using a commercially prepared chain lubricant. Reinstall hole cover.

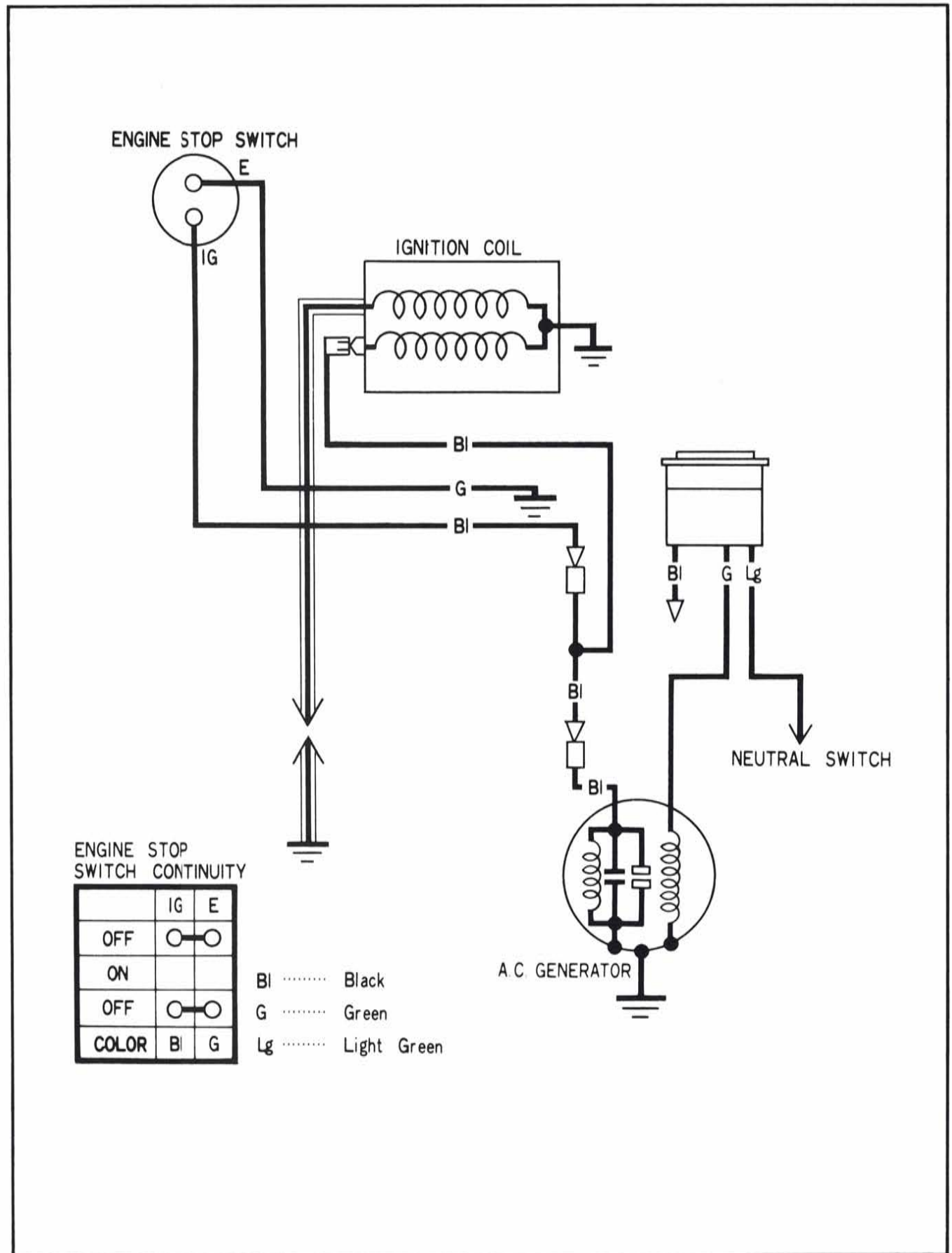

TORQUE TABLE

ITEM	SIZE	TORQUE
Front fork bolts	-----	4.5 kg-m (32 lb-ft)
Handlebar holder nuts	10 mm	4.5 kg-m (32 lb-ft)
Carrying handle bolts	8 x 16 mm	2.2 kg-m (16 lb-ft)
Rear wheel bolts	8 x 20 mm	2.2 kg-m (16 lb-ft)
Front axle nut	-----	7.0 kg-m (51 lb-ft)
Step guard bolts	8 x 25 mm	2.2 kg-m (16 lb-ft)
	10 x 16 mm	4.5 kg-m (32 lb-ft)
Recoil starter pulley bolts	6 mm	1.0 kg-m (8 lb-ft)

NOTE: Check all items listed on the following Pre-delivery Service Check List. Refer to owner's manual or shop manual for specifications and detailed procedures. Always test ride the unit to make sure that it is functioning properly.

PRE-DELIVERY SERVICE CHECK LIST

- | | |
|--|---|
| <ul style="list-style-type: none"> <input type="checkbox"/> Adjust rear brake, check cable routing and check operation. <input type="checkbox"/> Fill crankcase with recommended oil. <input type="checkbox"/> Inspect fuel tank, drain and flush, if necessary. <input type="checkbox"/> Drain residual fuel from carburetor. <input type="checkbox"/> Check valve clearance; adjust if necessary (1983 Model only). <input type="checkbox"/> Fill fuel tank, turn on petcock and check for leaks. <input type="checkbox"/> Clean and check contact points and ignition timing; and adjust if necessary (1983 Model only). <input type="checkbox"/> Adjust idle speed. <input type="checkbox"/> Check throttle lever free play, cable routing, and operation in all steering positions. <input type="checkbox"/> Adjust and lubricate drive chain. <input type="checkbox"/> Check tire pressure. | <ul style="list-style-type: none"> <input type="checkbox"/> Inspect electrical component for proper operation. <ul style="list-style-type: none"> • Engine stop switch. <input type="checkbox"/> Check security of all nuts, bolts, and other fasteners. <input type="checkbox"/> Check to ensure that all applicable recall and product update campaigns are complied with. <input type="checkbox"/> TEST RIDE: Check performance, handling, and operation. <ul style="list-style-type: none"> • Transmission and clutch: Ease of shifting, clutch operation, etc. • Acceleration: Smoothness, etc. • Cruising: Smoothness, etc. • Handling: Stability and cornering. • Brake: Smoothness and stopping power. • Idling: Smoothness, throttle response, return to idle. • Recheck idle speed after 10 minutes of stop and go operation. • Upon completion of test ride, check for fuel and oil leaks. |
|--|---|

1983 LOOSE PARTS

The following is a list of loose parts contained in the crate:

DESCRIPTION	H/C	PART NUMBER
Rear brake lever	046510	53178-147-0000
Screw, rear brake lever pivot	016914	90114-063-0000
Nut, hex head, 5 mm	015688	94001-0500-0S
Washer, lock, 10 mm (2 reqd.)	033092	94111-10800
Nut, hex head, 10 mm (2 reqd.)	034137	94001-10080-0S
Step guard, right	067395	50620-957-0000
Step guard, left	067396	50630-957-0000
Bolt-washer, 10 x 16 mm (2 reqd.), step guard	067489	93492-10016-08
Bolt-washer, 8 x 25 mm (2 reqd.), step guard	067491	93493-08025-08
Front fender	067406	61100-957-000AZ
Bolt, tapping (4 reqd.), front fender	067420	90202-957-000
Washer, (4 reqd.), front fender	029937	64348-086-000
Pin, cotter, 3 x 25 mm, front axle nut	005842	94201-30250
Carrying handle	067411	81200-957-000
Bolt-washer, 8 x 16 mm (4 reqd.), carrying handle	067490	93493-08016-08
Bolt-washer, 8 x 20 mm (6 reqd.), rear wheel	067488	93492-08020-00
Front wheel	-----	4430Z-957-000
Rear wheel (2 reqd.)	-----	4230Z-957-000
Screw, speed limiter, 5 x 14 mm	017179	93500-05018-0A
Nut, hex head, 5 mm, speed limiter	015688	94001-05000-0S
Owner's manual	128525	31957060

1984 LOOSE PARTS

The following is a list of loose parts contained in the crate:

DESCRIPTION	H/C	PART NUMBER
Rear brake lever	1506740	53178-957-000
Screw, parking brake lever pivot	1506823	90115-957-000
Nut, hex head, 5 mm	0057992	94001-05000
Washer, lock, 10 mm (2 reqd.)	0330928	94111-10800
Nut, hex head, 10 mm (2 reqd.)	0341370	94001-10080-0S
Step guard, right	0673954	50620-957-000
Step guard, left	0673962	50630-957-000
Bolt-washer, 10 x 16 mm (2 reqd.)	0674895	93492-10016-08
Bolt-washer, 8 x 25 mm (2 reqd.)	0674911	93493-08025-08
Front fender, R-109 passion red	0952028	61100-957-000ZB
Bolt, hex head, 6 x 20 mm (4 reqd.)	-----	92000-06020-OH
Collar, front fender (4 reqd.)	-----	90002-957-0000
Washer, plain, front fender (4 reqd.)	0629824	94103-06800
Pin, cotter, 3 x 25 mm, front axle nut	0058420	94201-30250
Carrying handle	0674119	81200-957-000
Bolt-washer, 8 x 16 mm (4 reqd.)	0674903	93493-08016-08
Bolt-washer, 8 x 20 mm (6 reqd.)	0674887	93492-08020-00
Front wheel	-----	44700-957-0000
Rear wheel (2 reqd.)	-----	42700-957-0000
Owner's manual	1507045	31957610

(

(

(

(

(

(

(

READ THIS READ THIS READ THIS

HONDA

MODIFICATIONS WHICH YOU HAVE MADE, OR SHOULD MAKE IN THE FUTURE, TO ANY HONDA MOTORCYCLE, SHALL BE DEEMED BY OUR COMPANY TO HAVE BEEN PERFORMED AT YOUR SOLE RISK AND RESPONSIBILITY, AND WITHOUT OUR COMPANY'S OR THE MANUFACTURER'S APPROVAL OR CONSENT, IMPLIED OR EXPRESSED. WE FURTHER DISCLAIM ANY AND ALL LIABILITY, OBLIGATION, OR RESPONSIBILITY FOR ANY DEFECTS OF MODIFIED PARTS OR OF THE MODIFIED MOTORCYCLE, AND FOR ANY CLAIMS, DEMANDS, OR CAUSES OF ACTION FOR DAMAGE TO PROPERTY OR FOR PERSONAL INJURIES RESULTING FROM THE MODIFICATION OF SAID HONDA MOTORCYCLE.

READ THIS READ THIS READ THIS

READ THIS READ THIS READ THIS