

# Set-up Instructions

AUG. 25 1983

# 1984 Model ATC 110



MPD 6116 8308  
AMERICAN HONDA MOTOR CO., INC.  
100 WEST ALONDRA BOULEVARD, GARDENA, CALIFORNIA 90247

**WARNING**

**WARNING**

**WARNING**

**WARNING**

**SET-UP AND PRE-DELIVERY SERVICE MUST BE PERFORMED BY AN AUTHORIZED HONDA MOTORCYCLE DEALER.** Proper set-up and pre-delivery service is essential to rider safety and reliability of the ATC. When a customer takes delivery of his brand new ATC, he expects it to be in excellent running condition. There are few things that will cause greater customer dissatisfaction than poor preparation of a new unit. An error or oversight made by the mechanic assembling and servicing a new unit can easily result in faulty operation, damage to the machine, or even injury to the rider.



*NOTE: Right and left are determined from the rider's view.*

Date of Issue: 8/83

# SET-UP INSTRUCTION REVISED PAGES

Pages Affected

Orig. Issue Date

Rev. Date

1 through 18

8/83

Original

Remove and destroy superseded pages.

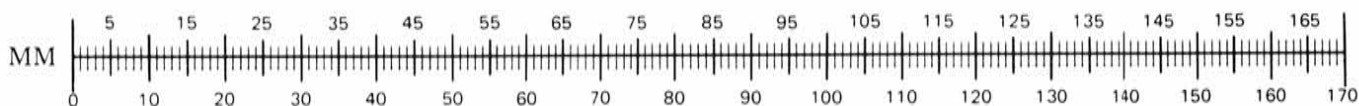

METRIC SCALE FOR DETERMINING BOLT LENGTHS/DIAMETERS

Pay special attention to warnings, cautions, and notes.

**WARNING** means hazards or unsafe practices which could cause severe personal injury or death.

**CAUTION:** means hazards or unsafe practices which could cause minor personal injury or product or property damage.

*NOTE:* gives helpful information.

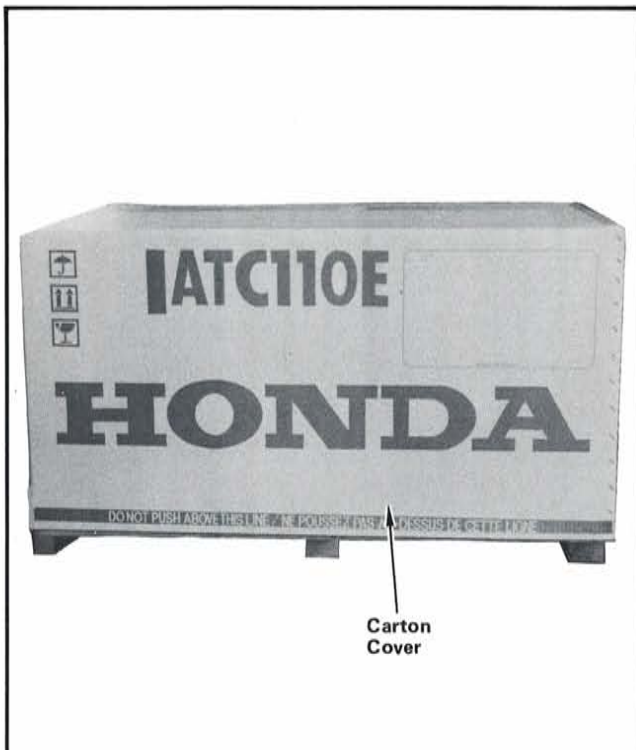

**STEP 1**—Cut straps and lift off carton cover.

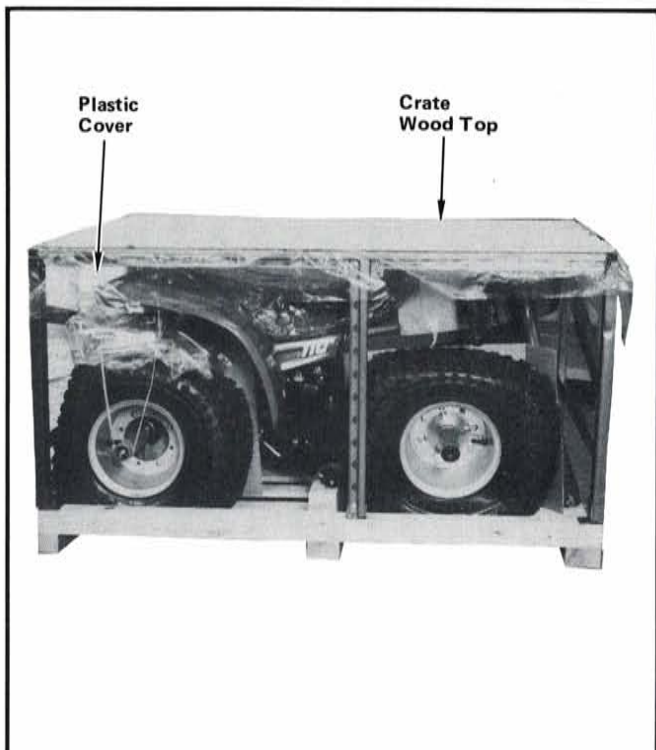

**STEP 2**—Remove crate wood top and plastic cover.

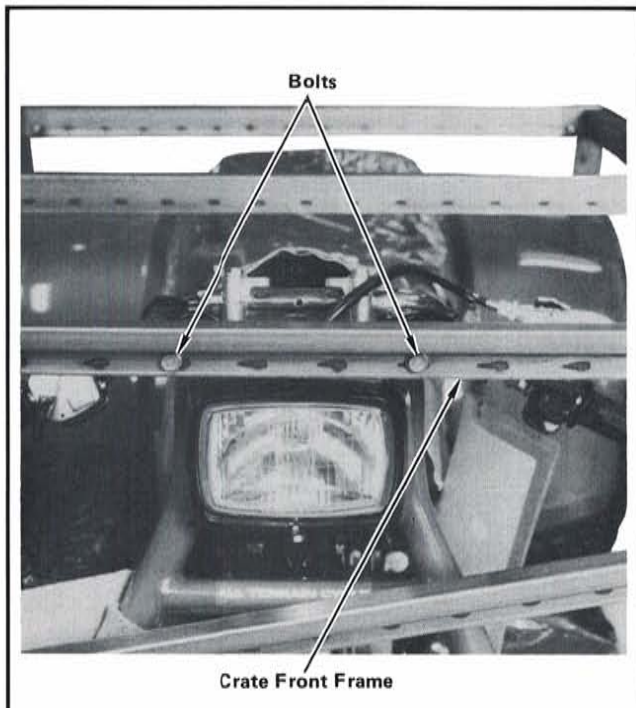

**STEP 3**—Remove two bolts attaching crate front frame to shipping brace located on top of front forks.

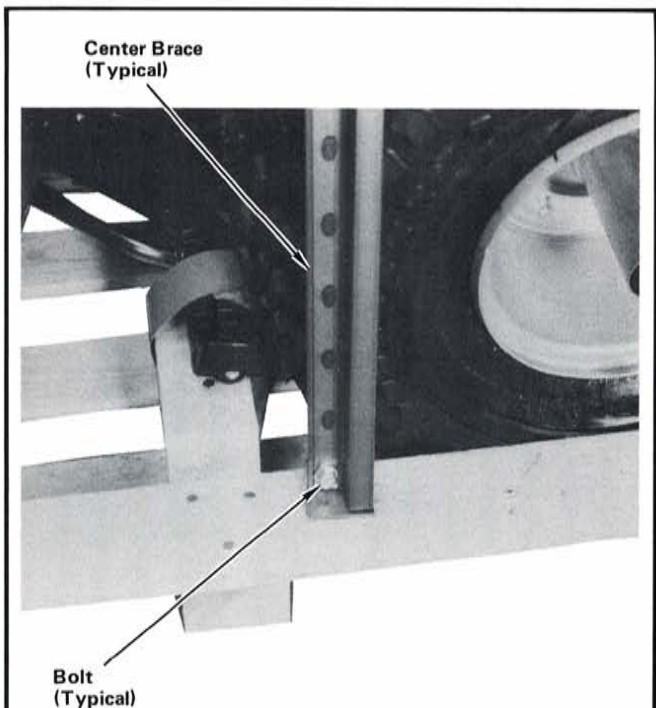

**STEP 4**—Remove bolts attaching center braces to crate base.

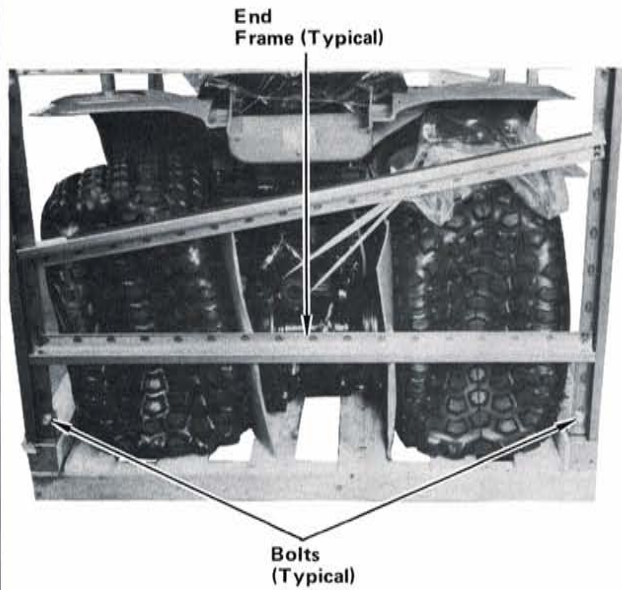

**STEP 5**—Remove bolts attaching front and rear end frames to crate base. Carefully lift off crate frame using two people.

**CAUTION:** Use extreme care not to damage ATC with crate frame.

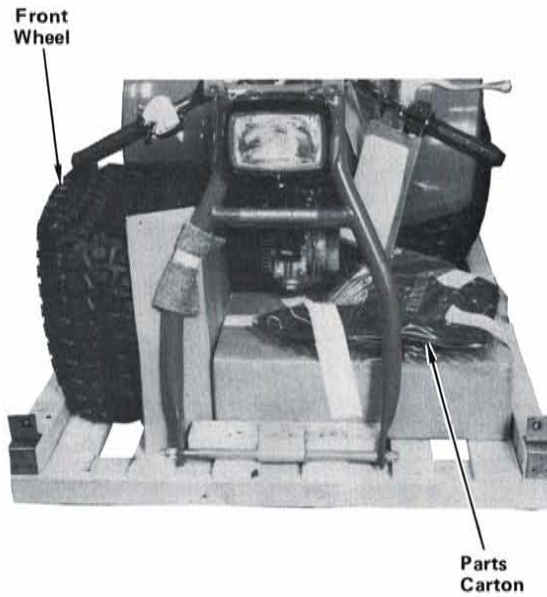

**STEP 6**—Remove front wheel and parts carton from crate base.

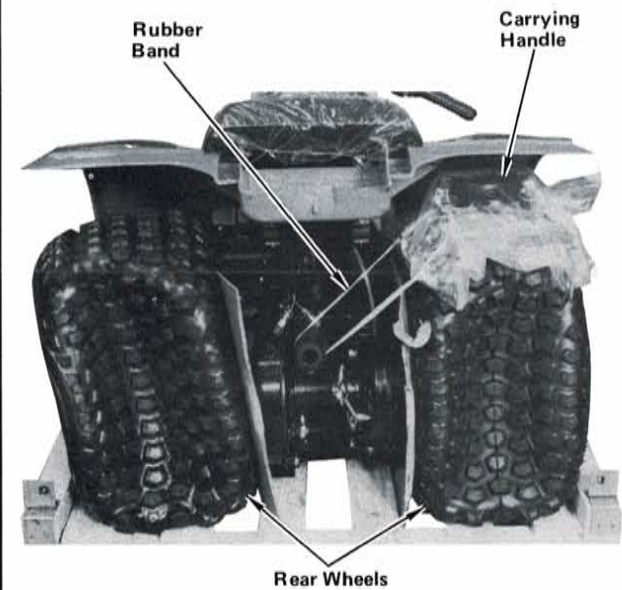

**STEP 7**—Remove carrying handle from behind rear wheel by removing rubber band. Remove rear wheels from crate base.

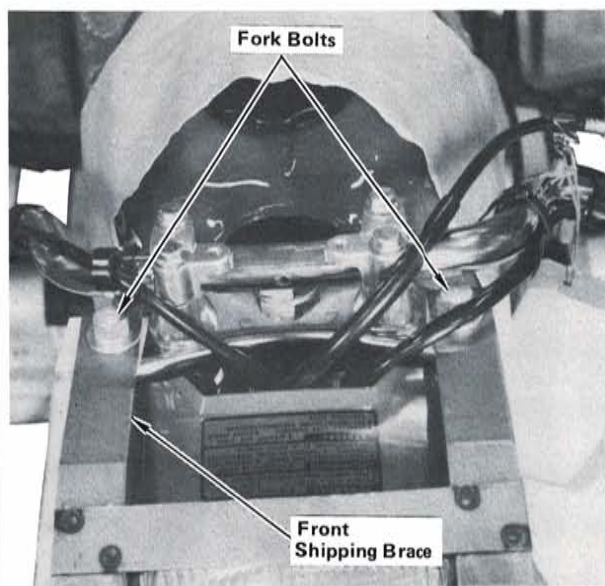

**STEP 8**—Loosen fork bolts and remove front shipping brace. Retighten fork bolts to specified torque.

**Torque specification:**  
6 kg-m (43 lb-ft)

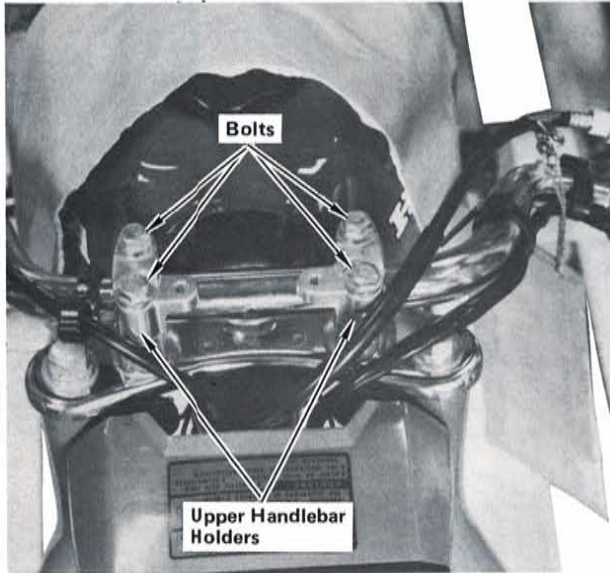

**STEP 9**—Loosen four bolts attaching upper handlebar holders.

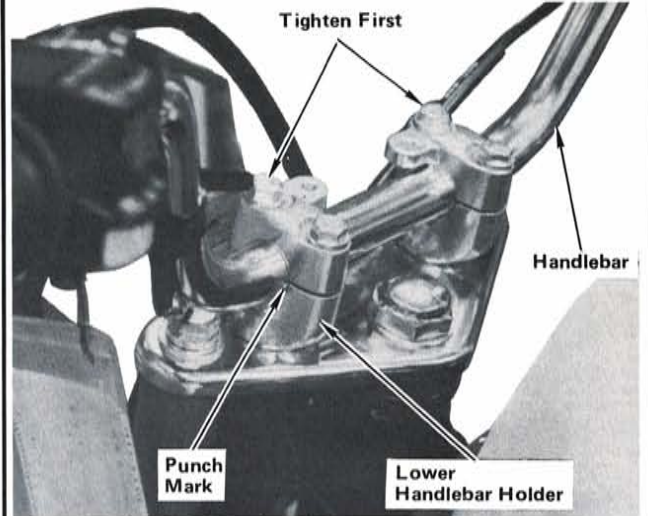

**STEP 10**—Raise handlebar grips until punch mark on handlebar is aligned with top of lower holder and serrations are aligned with lower holders. Tighten forward bolts to specified torque first, then tighten rear bolts to same torque.

**Torque specification:**  
2.4 kg-m (18 lb-ft)

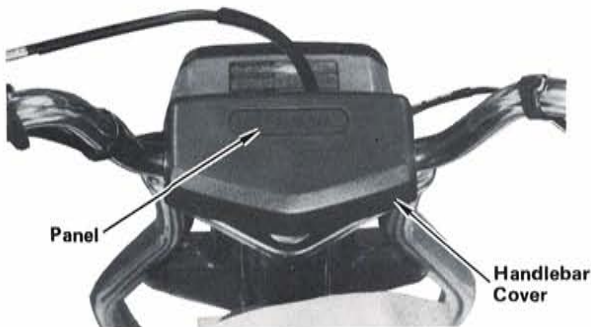
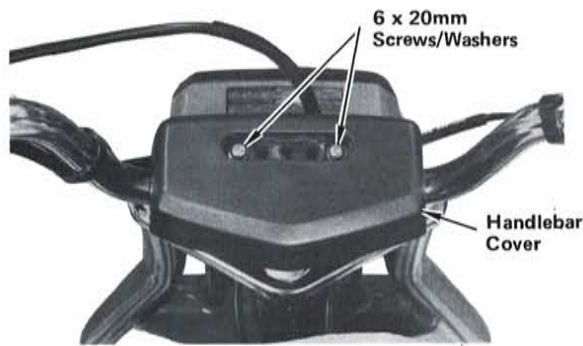

**STEP 11**—Remove panel from handlebar cover and install cover as shown using two 6 x 20 mm screws/washers. Tighten screws securely and reinstall panel as shown.

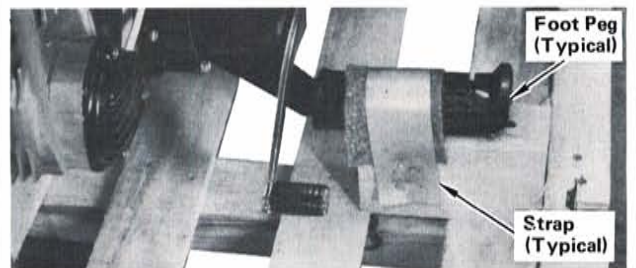
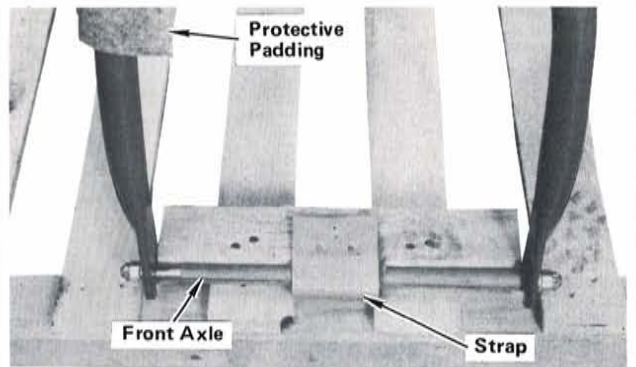

**STEP 12**—Remove straps holding front axle and foot pegs to crate base, by removing nails. Remove protective padding from front forks.

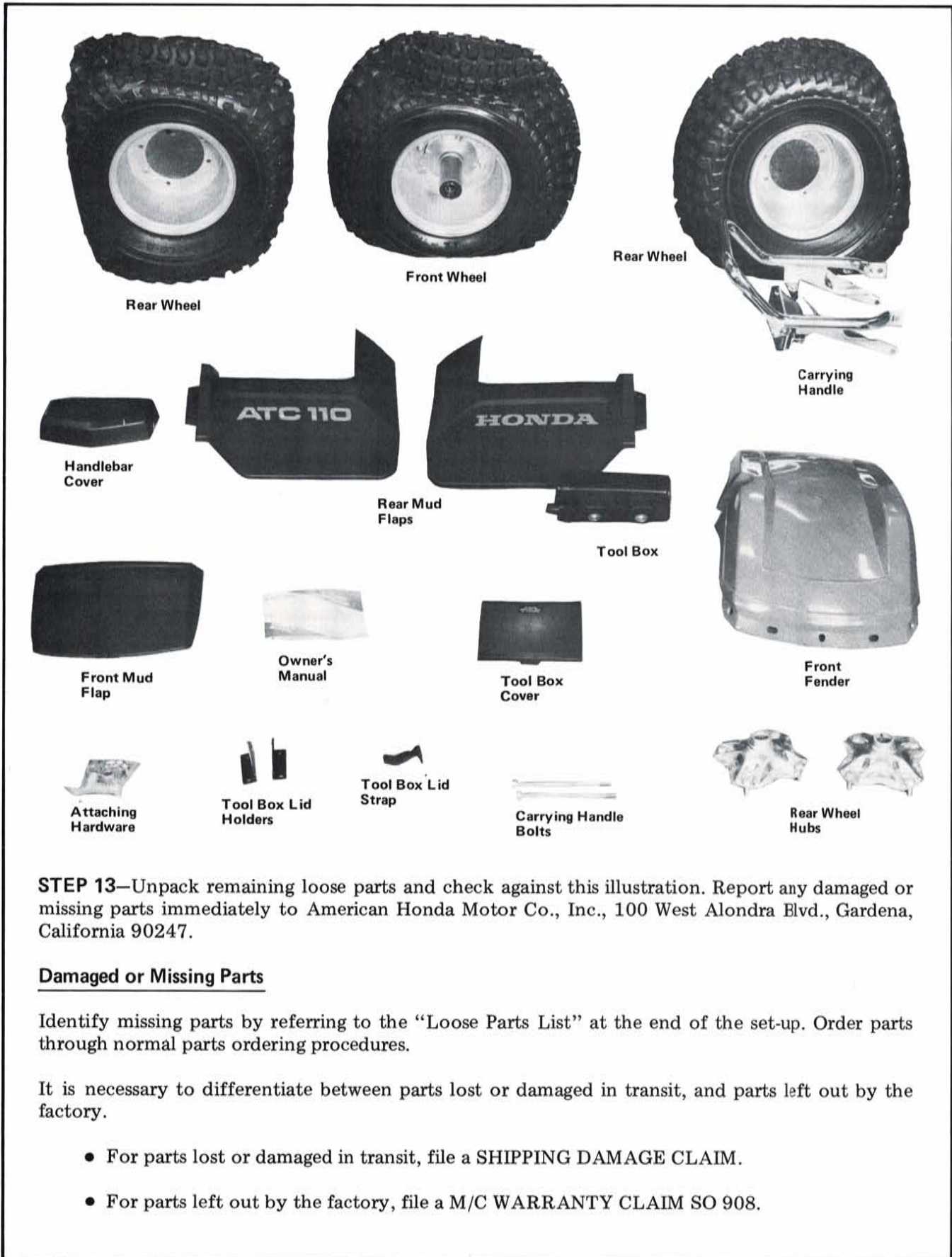

**STEP 13**—Unpack remaining loose parts and check against this illustration. Report any damaged or missing parts immediately to American Honda Motor Co., Inc., 100 West Alondra Blvd., Gardena, California 90247.

**Damaged or Missing Parts**

Identify missing parts by referring to the "Loose Parts List" at the end of the set-up. Order parts through normal parts ordering procedures.

It is necessary to differentiate between parts lost or damaged in transit, and parts left out by the factory.

- For parts lost or damaged in transit, file a SHIPPING DAMAGE CLAIM.
- For parts left out by the factory, file a M/C WARRANTY CLAIM SO 908.

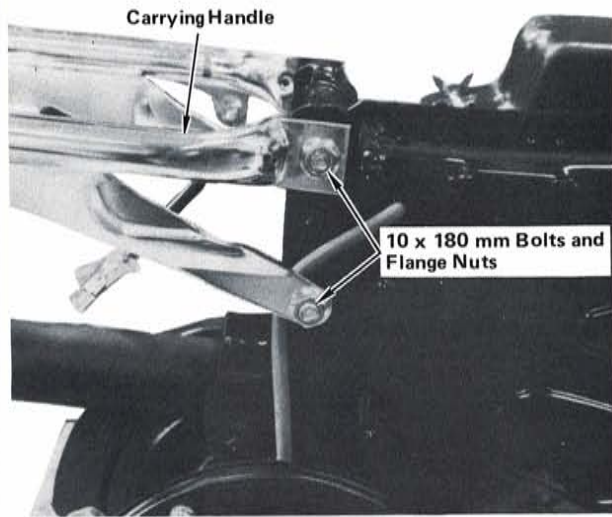

**STEP 14**—Remove rear fender/seat. Position carrying handle with curve up as shown and install using two 10 x 180 mm bolts and flange nuts. Tighten nuts to specified torque.

**Torque specification:**  
4.0 kg-m (29 lb-ft)

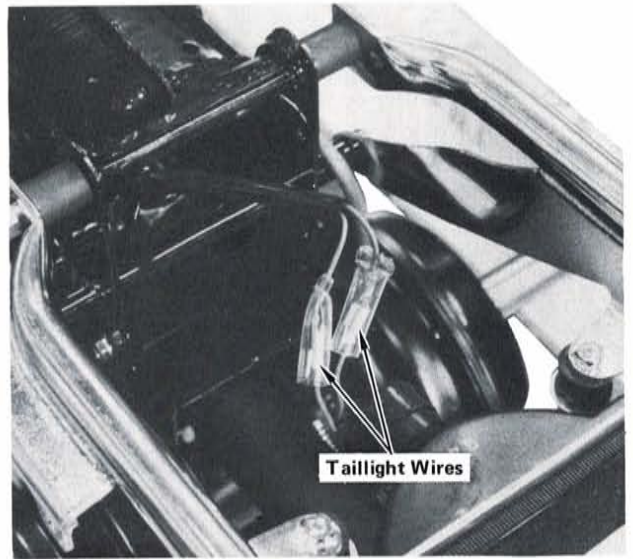

**STEP 15**—Connect taillight wires color-to-color.

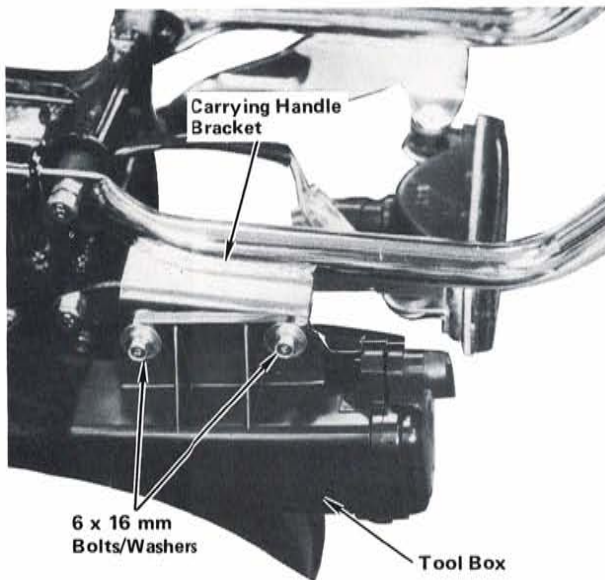

**STEP 16**—Position tool box on carrying handle bracket and install using two 6 x 16 mm bolt/washer combinations. Tighten bolts securely.

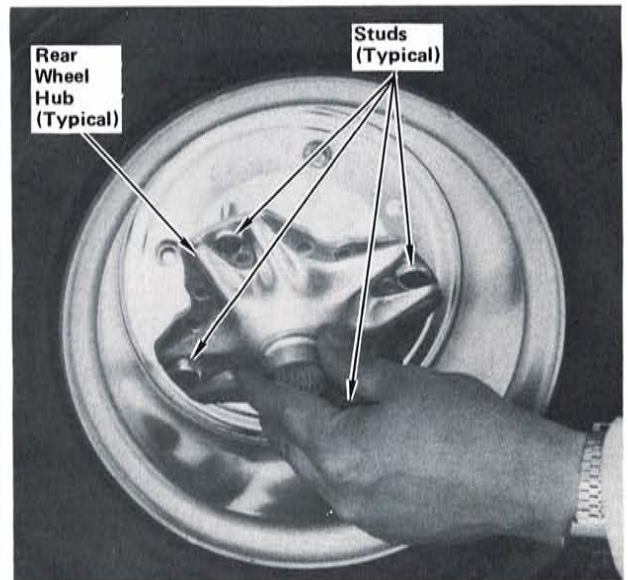

**STEP 17**—Insert studs of rear wheel hubs through rear wheels from side opposite valve stem.

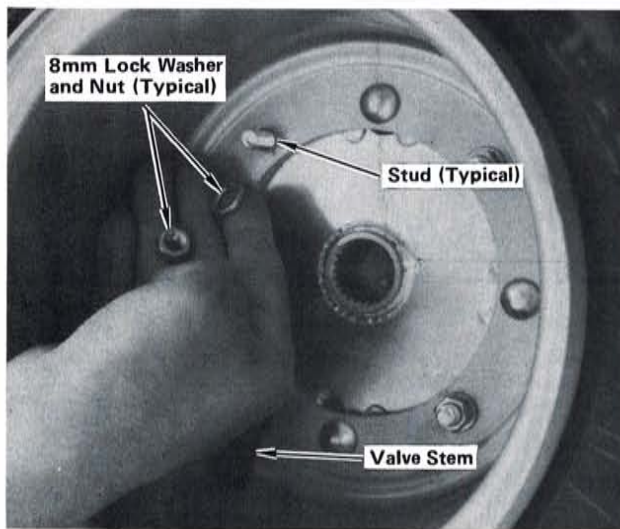

**STEP 18**—Install each rear wheel hub using four 8 mm lock washers and nuts on side of wheel having valve stem. Repeat step for other wheel. Tighten nuts to specified torque.

**Torque specification:**  
2.2 kg-m (16 lb-ft)

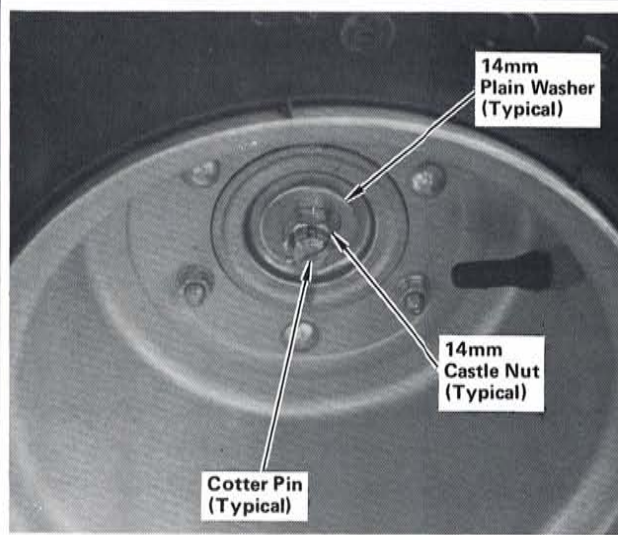

**STEP 19**—Grease axle splines and install rear wheels, with valve stems to the outside, using a 14 mm plain washer and castle nut for each. Tighten both rear axle nuts to specified torque and install a cotter pin in each. Spread ends of cotter pin as shown.

**Torque specification:**  
7 kg-m (51 lb-ft)

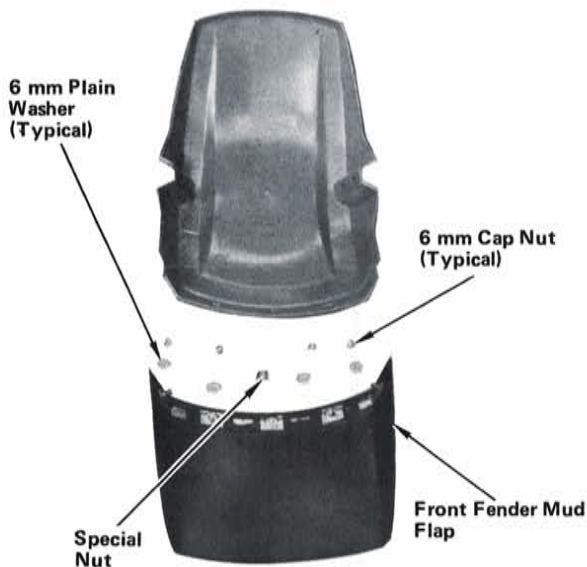

**STEP 20**—Install front fender mud flap using four 6 mm plain washers, cap nuts and one special nut. Tighten nuts to specified torque.

**Torque specification:**  
0.8 kg-m (6 lb-ft)

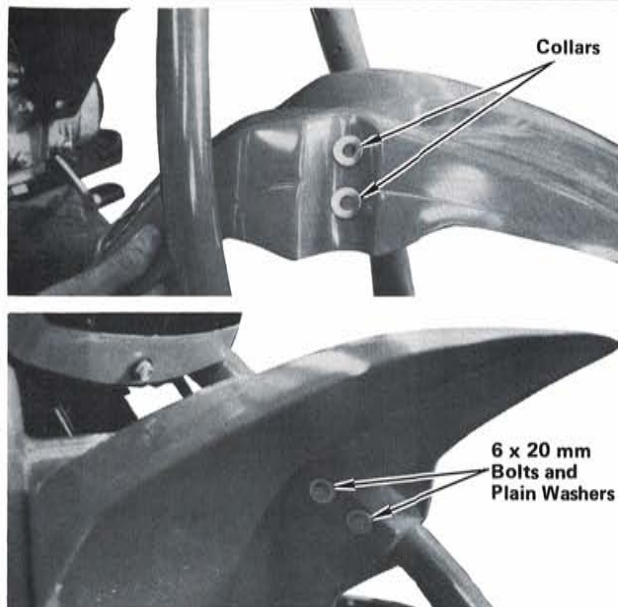

**STEP 21**—Position front fender between fork legs and install using four 6 x 20 mm bolts, plain washers and collars as shown. Tighten bolts to specified torque.

**Torque specification:**  
1.0 kg-m (8 lb-ft)



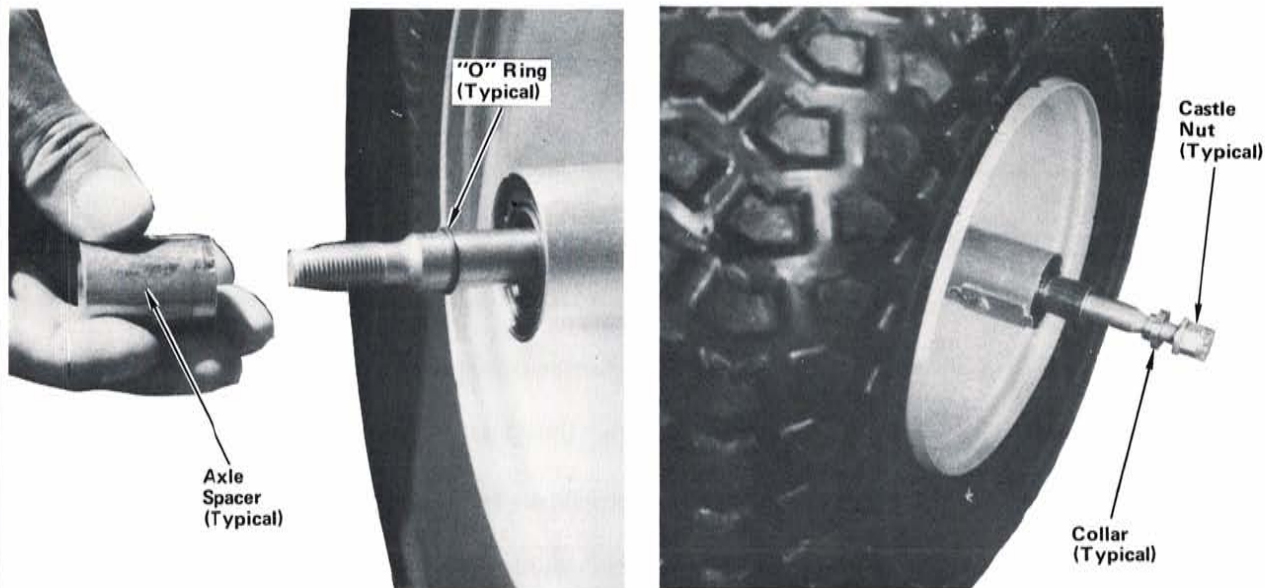

**STEP 22**—Remove front axle from fork legs. Grease front wheel hub seals and insert front axle in front wheel hub. Slip an O-ring and spacer over each end of front axle and push into seal. Install a collar and castle nut on each end of front axle as shown but do not tighten at this time.

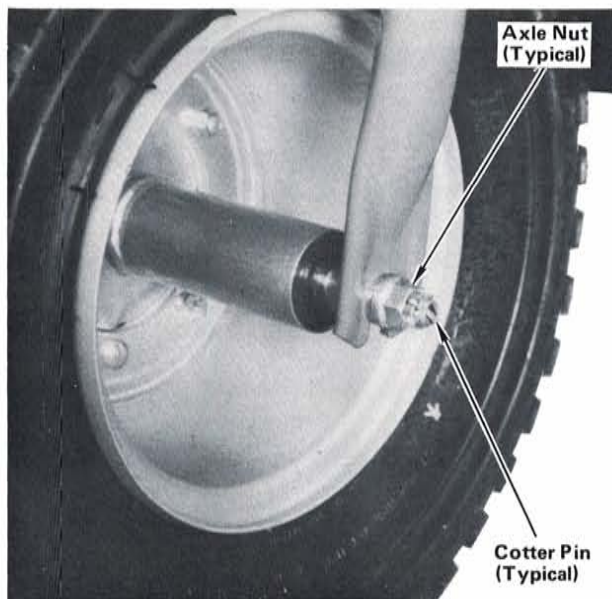

**STEP 23**—Install front wheel between fork legs and tighten both axle nuts to specified torque. Install a cotter pin through each axle nut and spread ends as shown.

**Torque specification:**  
6 kg-m (43 lb-ft)

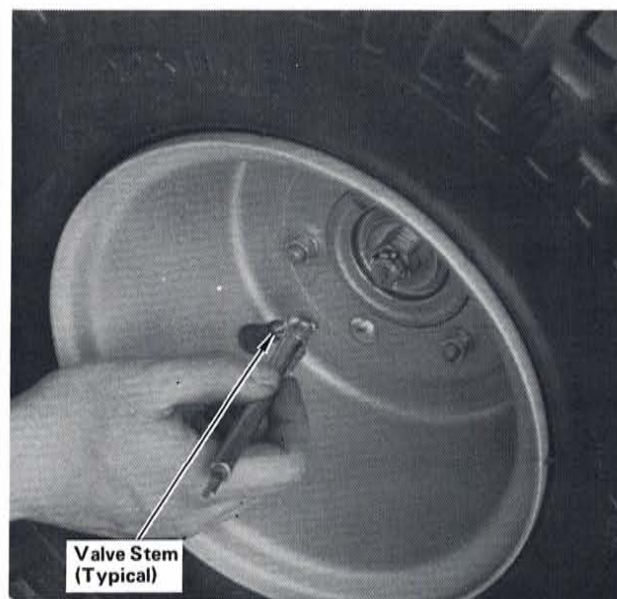

**STEP 24**—Inflate all tires and check tire pressure.  
All tires: 2.2 psi.

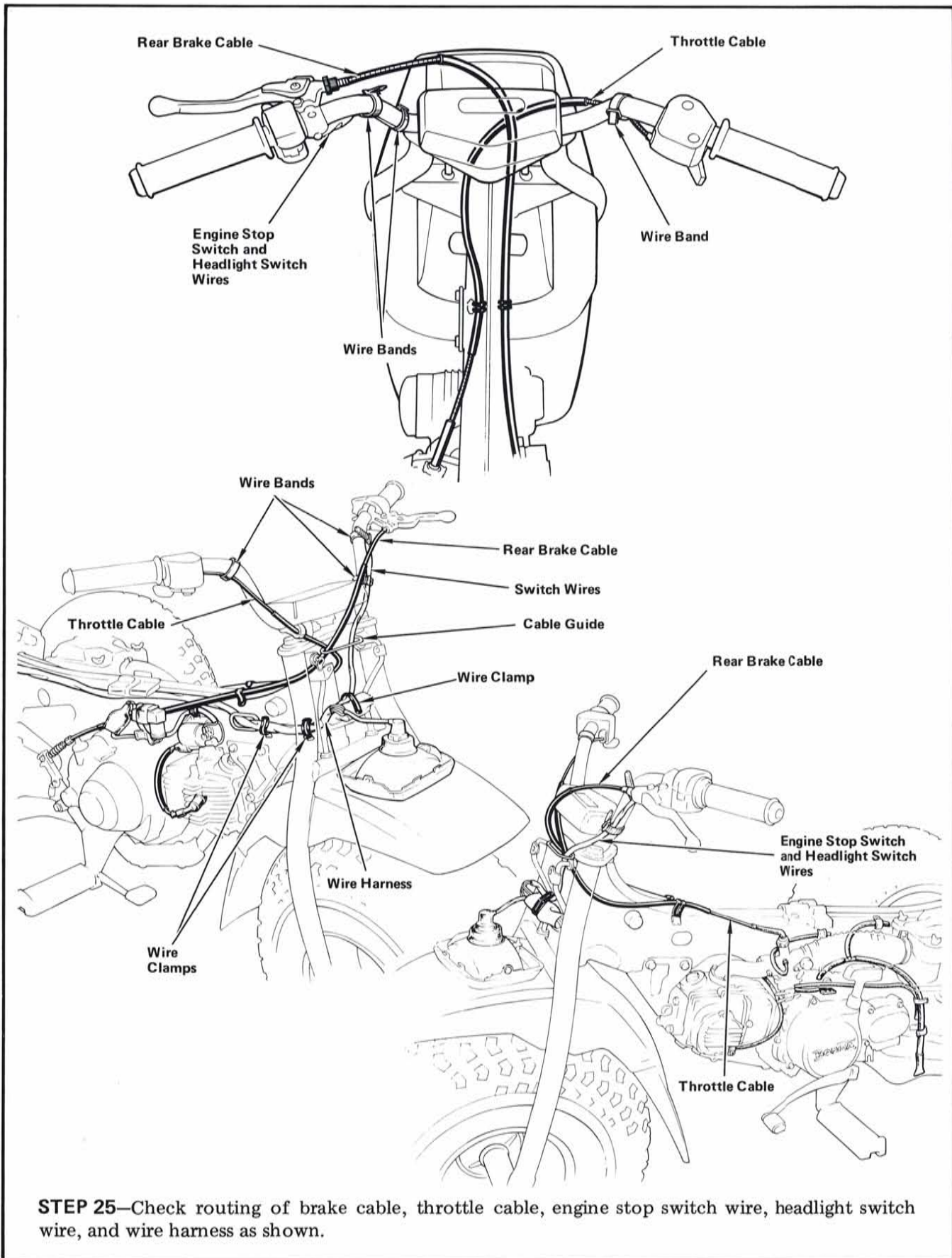

**STEP 25**—Check routing of brake cable, throttle cable, engine stop switch wire, headlight switch wire, and wire harness as shown.

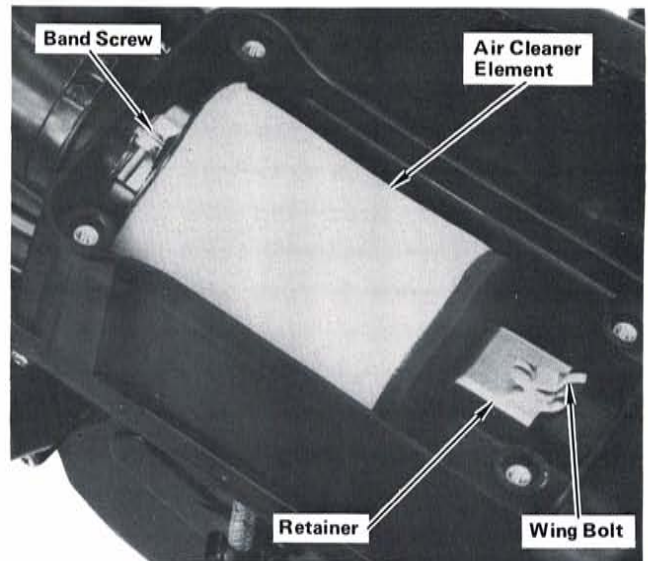
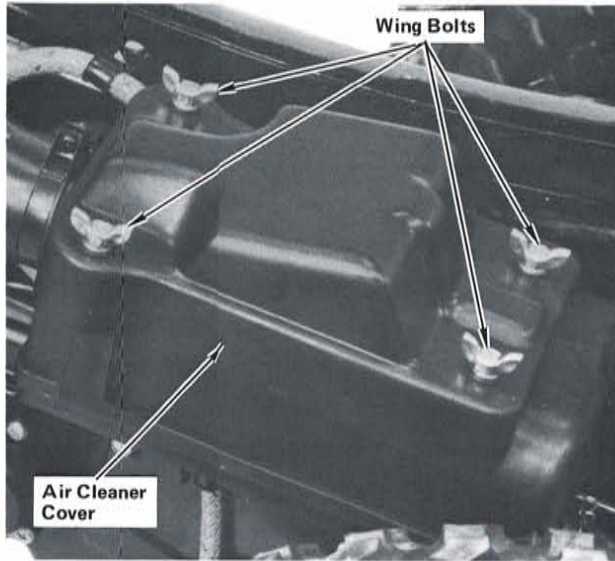

**STEP 26**—Remove wing bolts attaching air cleaner cover and retainer. Loosen air cleaner band screw. Remove air cleaner element assembly from air cleaner case. Remove retainer from air cleaner core and remove air cleaner element. Check condition of element. If necessary, clean element as described in owner's manual or shop manual. Reinstall element, retainer, and assembly into air cleaner case. Tighten air cleaner band screw. Reinstall air cleaner cover and tighten wing bolts securely.

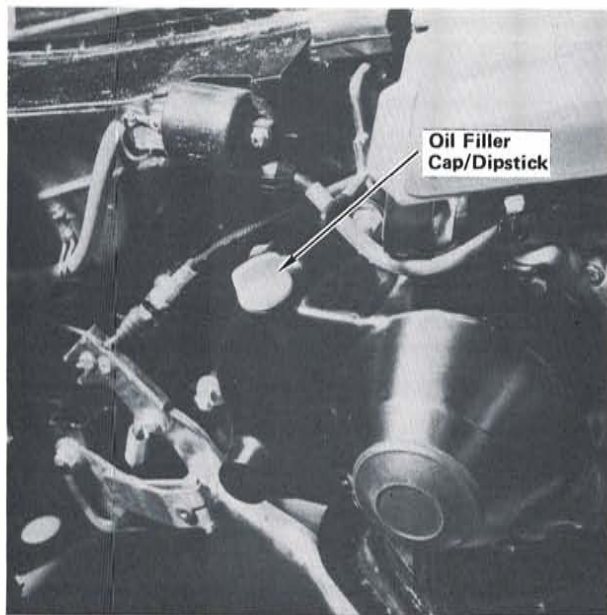

**STEP 27**—Remove oil filler cap and fill crankcase with recommended oil as described in owner's manual. Reinstall and tighten cap.

*NOTE: Do not drain oil until break-in period has been completed.*

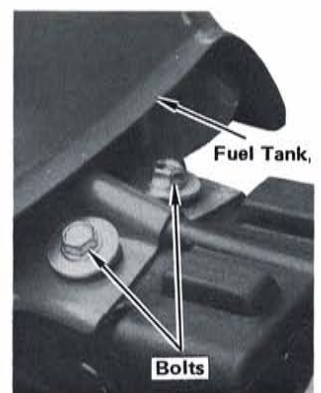

**STEP 28**—Remove protective wrapping from fuel tank. Drain fuel tank as described in owner's manual. Remove fuel tank by disconnecting fuel lines and removing two bolts at rear of the tank. Inspect and flush tank. Reinstall fuel tank using the two bolts removed, and connect fuel lines. Tighten bolts securely. Drain residual fuel from carburetor.

**WARNING** Fuel must be drained into a proper container. Gasoline is flammable and explosive under certain conditions. Do not smoke or allow flames or sparks near while draining fuel.

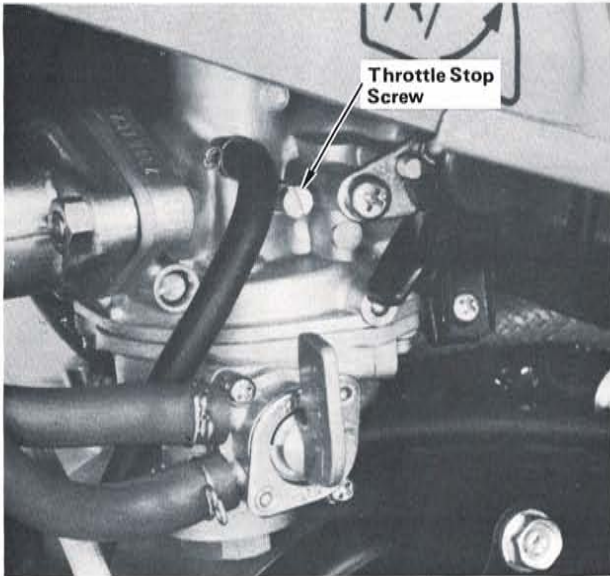

**STEP 29**—Connect a tachometer. Start engine and warm it up to operating temperature. Adjust idle speed to 1,700 rpm using throttle stop screw. Stop engine and disconnect the tachometer.

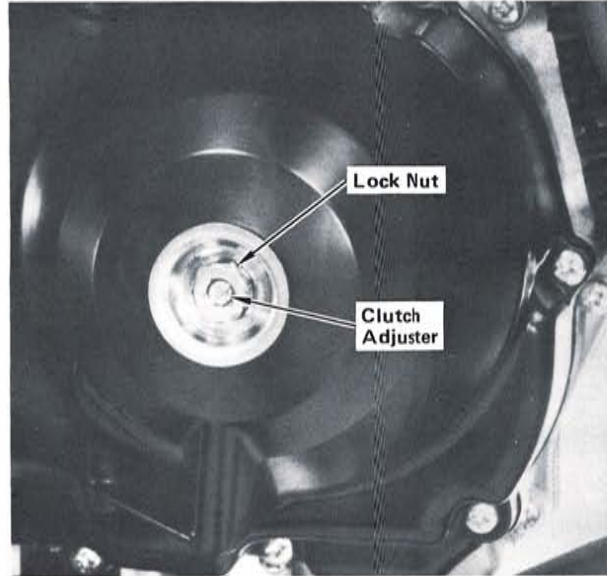

**STEP 30**—Check clutch operation. If adjustment is necessary, use the following procedure. Loosen lock nut and turn clutch adjuster counterclockwise until resistance is felt, then turn clutch adjuster 1/8 turn clockwise and tighten lock nut. Recheck clutch operation.

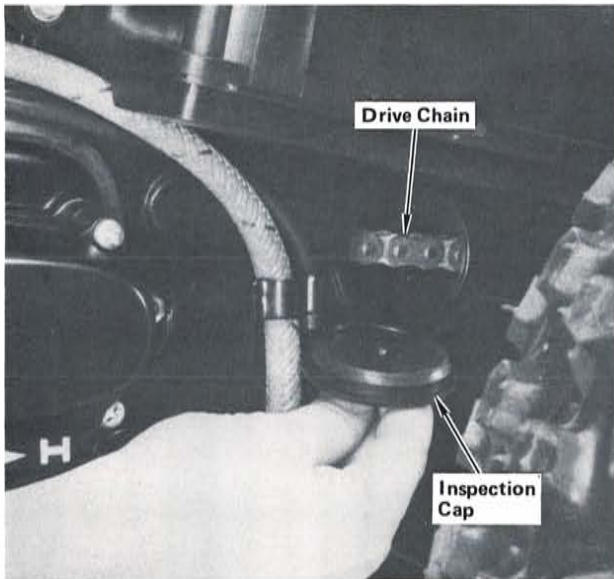

**STEP 31**—Remove drive chain inspection cap and check chain slack. If adjustment is necessary, loosen rear hub bolts and turn adjusting nut to obtain correct slack. After adjustment, tighten rear hub bolts and lock nut then recheck chain slack. Lubricate drive chain and reinstall chain inspection cap.

**Drive chain slack: 10–20 mm (3/8–3/4 in.)**

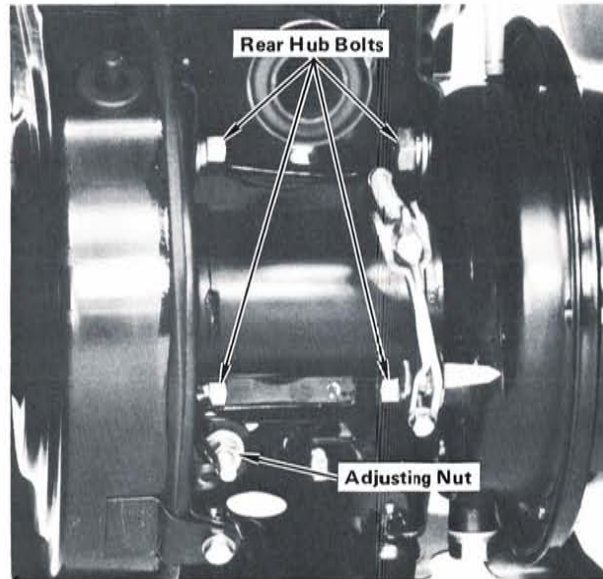

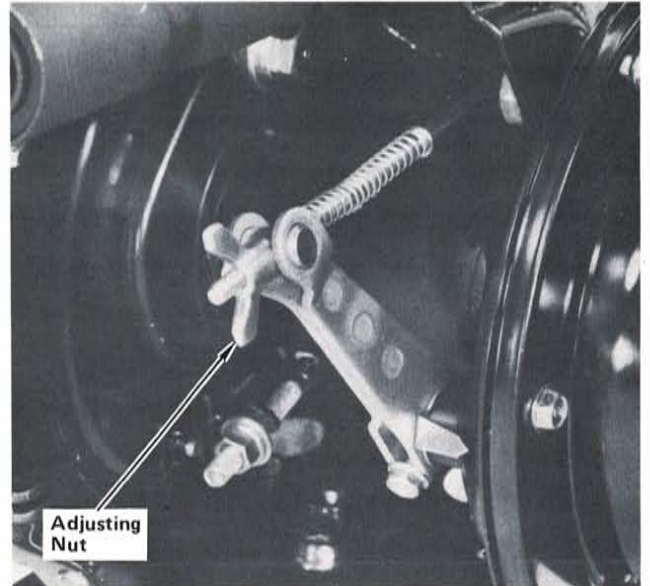
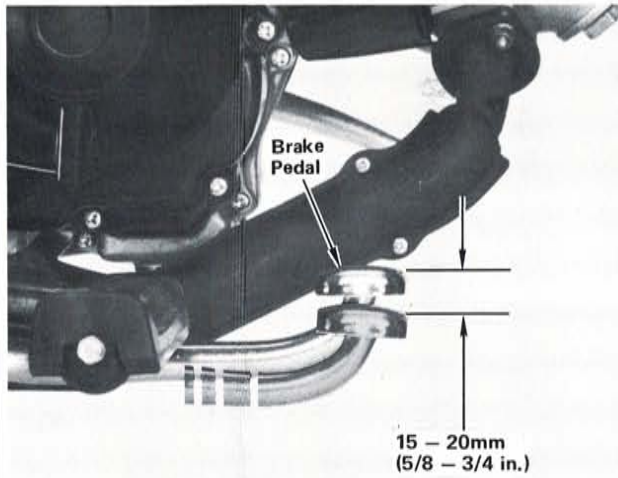

**STEP 32**—Check brake pedal free play. If adjustment is necessary, turn adjusting nut on brake rod at rear of frame.

**Free Play:** 15–20 mm (5/8–3/4 in.)

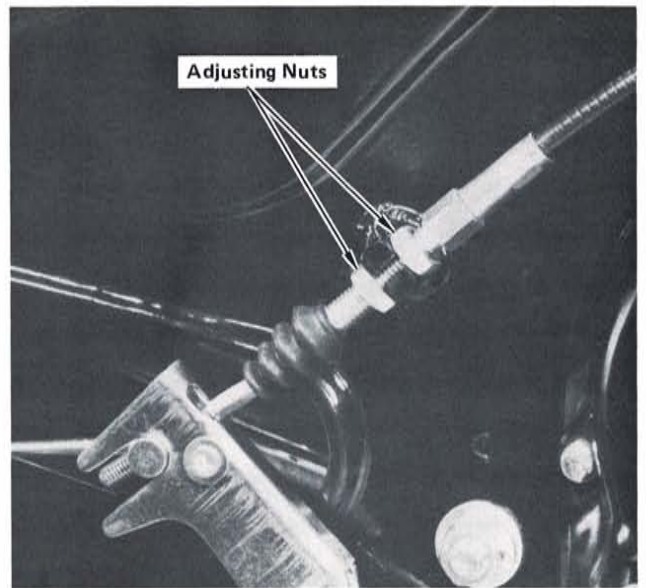
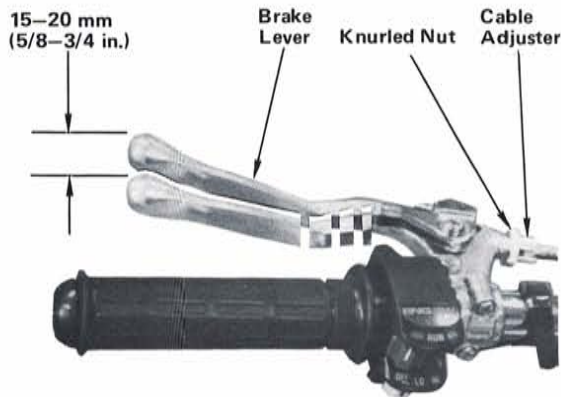

**STEP 33**—Place a block under ATC. Spin rear wheels by hand and measure free play of rear brake hand lever before brake starts to engage. Free play, measured at tip of rear brake hand lever should be between 15 and 20 mm (5/8–3/4 in.). Use adjusting nuts on rear brake arm to make large adjustments. Small adjustments are made at rear brake hand lever by loosening knurled nut and turning cable adjuster. After adjustment, tighten knurled nut. Remove block from under ATC.

**Free Play:** 15–20 mm (5/8–3/4 in.)

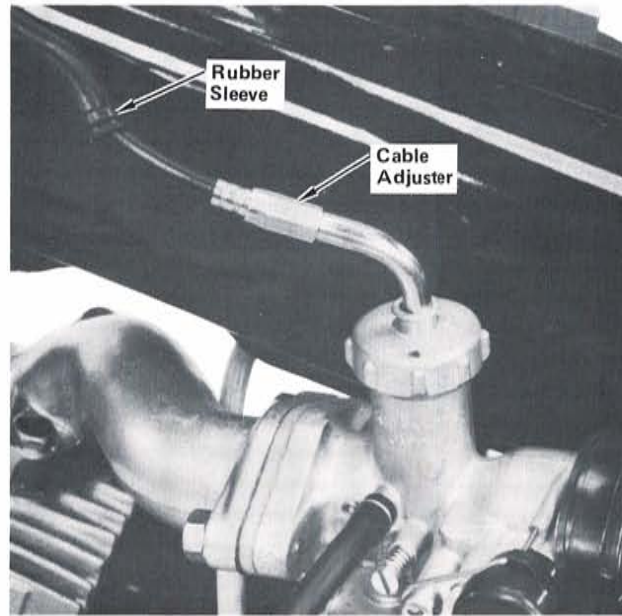
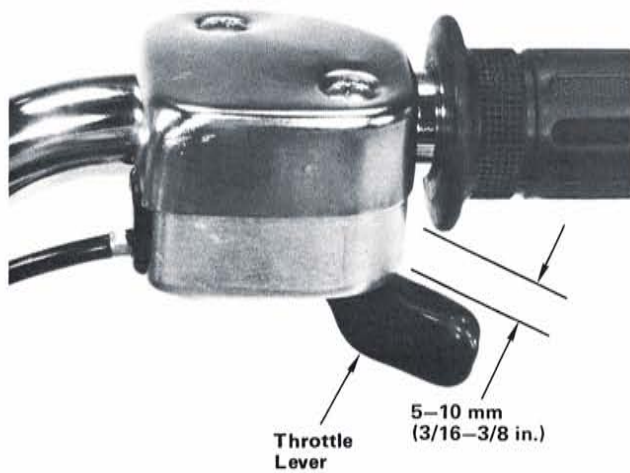

**STEP 34**—Check throttle lever free play. If adjustment is necessary, slide rubber sleeve on carburetor forward and turn throttle cable adjuster as necessary. Slide rubber sleeve back over adjuster.

Throttle lever free play: 5–10 mm (3/16–3/8 in.)

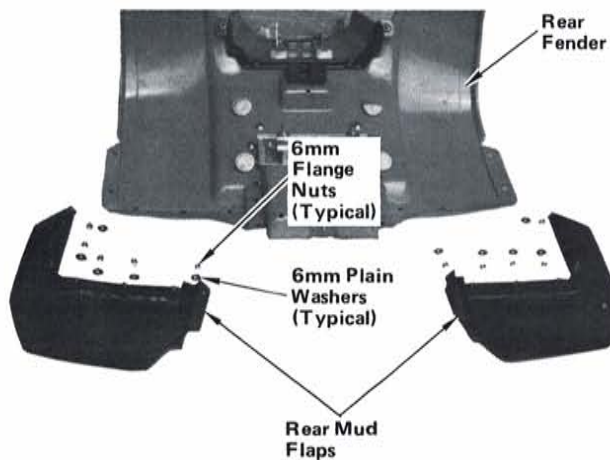

**STEP 35**—Install right and left rear mud flaps on rear fender by inserting studs on mud flaps down through fender with 6 mm plain washers and flange nuts under fender. Tighten nuts to specified torque.

**Torque specification:**  
0.8 kg-m (6 lb-ft)

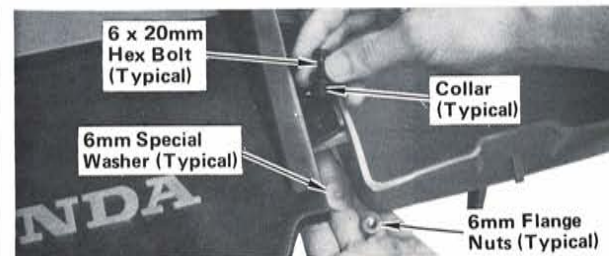
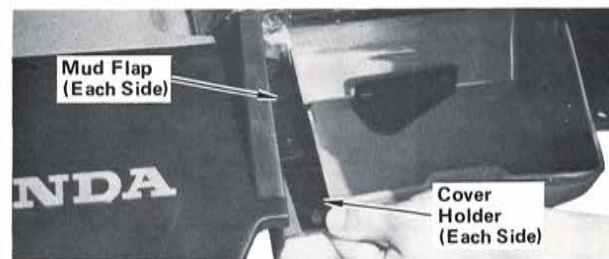

**STEP 36**—Position tool box cover holders (one on each side) between mud flap and rear fender and align the holes. Install holders using four 6 x 20 mm black hex bolts and collars down through holes, and four 6 mm special washers and flange nuts under fender. Tighten nuts securely.

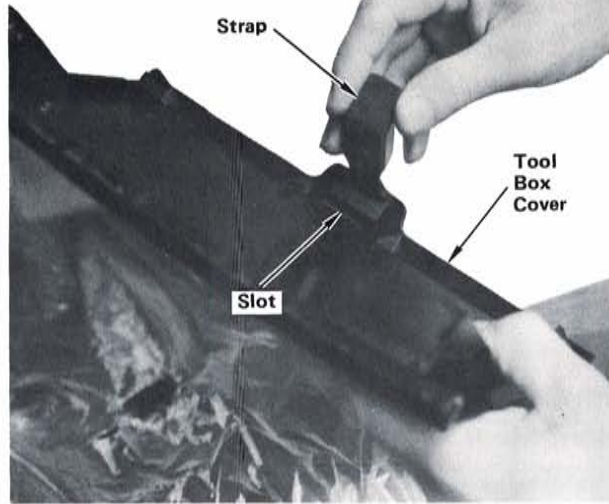

**STEP 37**—Install tool box cover strap as shown by coating end of rubber with soapy water and inserting end into slot in tool box cover.

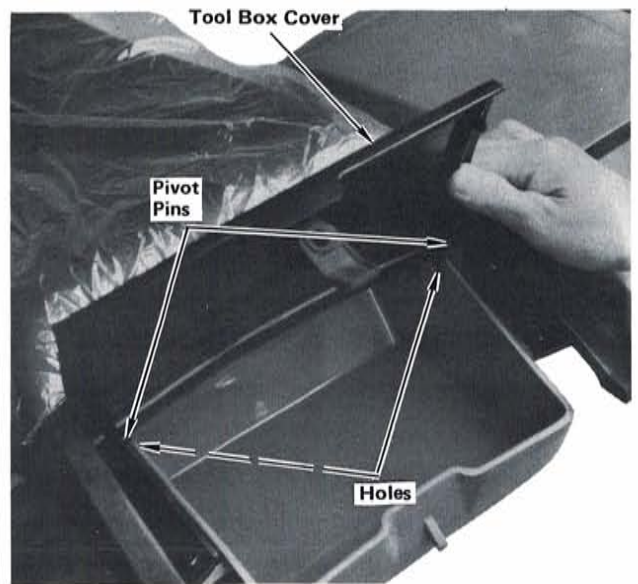

**STEP 38**—Snap tool box cover pivot pins into holes of cover holders as shown.



**STEP 39**—Install and latch rear fender/seat.

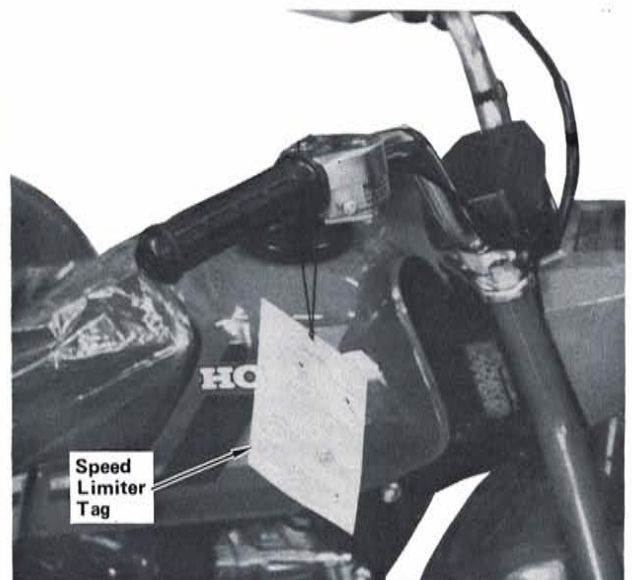

**STEP 40**—Hang speed limiter tag onto handlebar.

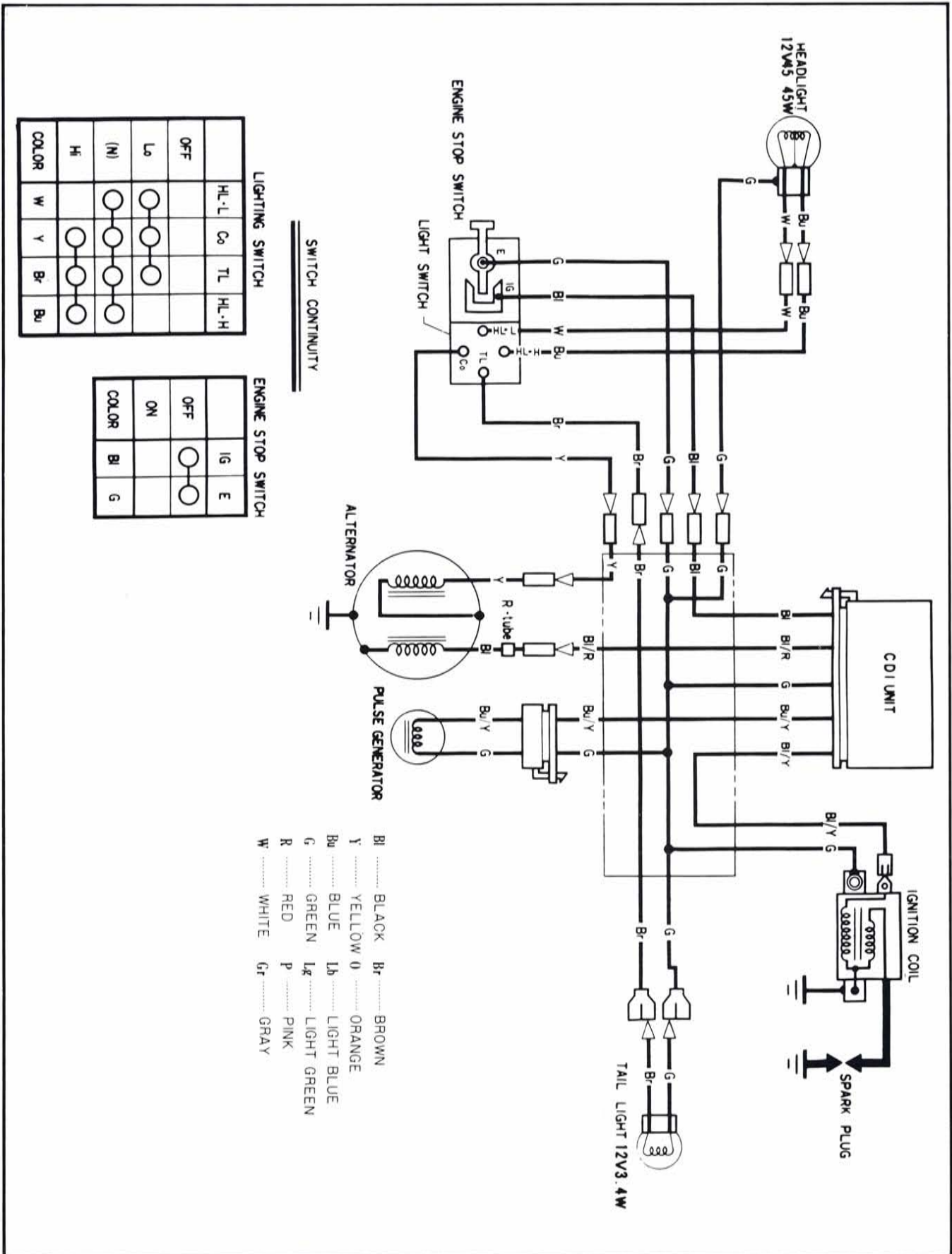



## TORQUE TABLE

ITEM	SIZE	TORQUE
Front fork bolts	-----	6.0 kg-m (44 lb-ft)
Handlebar holder bolts		2.4 kg-m (18 lb-ft)
Carrying handle bolts	10 x 180 mm	4.0 kg-m (29 lb-ft)
Rear wheel flange nuts	8 mm	2.2 kg-m (16 lb-ft)
Rear axle nuts	14 mm	7.0 kg-m (51 lb-ft)
Front fender bolts	6 x 16 mm	1.0 kg-m (8 lb-ft)
Front axle nuts	12 mm	7.0 kg-m (51 lb-ft)

*NOTE: Check all items listed on the following Pre-delivery Service Check List. Refer to owner's manual for specifications and detailed procedures. Always test ride the unit to make sure that it is functioning properly.*

## PRE-DELIVERY SERVICE CHECK LIST

- |  |   |
|--|---|
| <ul style="list-style-type: none"> <li><input type="checkbox"/> Adjust rear brake, check cable routing and check operation.</li> <li><input type="checkbox"/> Fill crankcase with recommended oil.</li> <li><input type="checkbox"/> Remove and inspect fuel tank, drain and flush.</li> <li><input type="checkbox"/> Drain residual fuel from carburetor.</li> <li><input type="checkbox"/> Reinstall fuel tank, fill, turn on petcock, and check for leaks.</li> <li><input type="checkbox"/> Adjust idle speed.</li> <li><input type="checkbox"/> Check throttle lever free play, cable routing, and operation in all steering positions.</li> <li><input type="checkbox"/> Adjust and lubricate drive chain.</li> <li><input type="checkbox"/> Check tire pressure.</li> </ul> | <ul style="list-style-type: none"> <li><input type="checkbox"/> Inspect electrical components for proper operation and adjustment.           <ul style="list-style-type: none"> <li>• Headlight switch.</li> <li>• Headlight: Adjust high and low beam aim.</li> <li>• Taillight.</li> <li>• Engine stop switch.</li> </ul> </li> <li><input type="checkbox"/> Check security of all nuts, bolts and other fasteners.</li> <li><input type="checkbox"/> Check to ensure that all applicable recall and product update campaigns are complied with.</li> <li><input type="checkbox"/> <b>TEST RIDE:</b> Check performance, handling, and operation.           <ul style="list-style-type: none"> <li>• Transmission: high-low gear range selector, and clutch: Ease of shifting, clutch operation, etc.</li> <li>• Acceleration: Smoothness, etc.</li> <li>• Cruising: Smoothness, etc.</li> <li>• Handling: Stability and cornering.</li> <li>• Brakes: Smoothness and stopping power.</li> <li>• Idling: Smoothness, throttle response, and return to idle.</li> <li>• Recheck idle speed after 10 minutes of stop and go operation.</li> <li>• Upon completion of test ride, check for fuel and oil leaks.</li> </ul> </li> </ul> |
|--|---|

## LOOSE PARTS

The following is a list of items contained in the parts package carton and loose parts in the crate:

DESCRIPTION	QTY	H/C	PART NUMBER
Front fender R-109 passion red	1	1520840	61110-943-023EA
Collar	4	-----	90002-957-0000
6 x 20 mm hex bolt	4	0442103	92000-06020-0H
Front mud guard	1	1536580	61111-943-033
6 mm plain washer	8	0629824	94103-06800
6 mm cap nut	4	0203620	94021-06000-0S
6 x 16 mm special nut	1	1508985	90301-943-0000
Rear fender			
Right rear holder	1	1412980	80251-943-013
Left rear holder	1	1405356	80256-943-0133
6 x 20 mm hex bolt	4	150897	90195-943-000
Rear mud guard collar	4	1520881	80117-943-010
6 mm plain washers	14	0629824	94103-06800
Right rear mud guard	1	1520873	80111-943-800
Left rear mud guard	1	1508845	80116-968-000
6 mm flange nut	14	0612689	94050-06080
Carry pipe			
10 x 180 mm hex bolt	2	0263079	90196-918-000
10 mm flange nut	2	0623405	94050-10080
Handle cover	1	1285816	53205-943-003
Handle cover mark	1	1274760	53206-958-003
6 x 20 mm screw/washer	2	0878538	93891-06020-08
Front wheel			
Front axle	1	1495985	44301-943-000
Axle collar	2	1510460	44302-968-000
Side collar	2	1508548	44312-968-000
Axle nut	2	0955625	90305-169-000
Cotter pin	2	0058420	94201-30250
O-ring	2	0347906	91307-611-000
Rear wheel			
Rear wheel hub	2	1275163	42410-958-671
8 mm lock washer	8	0058982	94111-08000
8 mm hex nut	8	0058032	94-001-08000-0S
Washer	2	1074327	42322-950-000
Castle nut	2	0109454	94011-14000-0S
Cotter pin	2	0058420	94201-30250
Tool set	1	1538867	89000-943-800
Tool box	1	-----	83500-968-0001
6 x 20 mm washer	2	0665133	93493-06016-08
Tool box cover	1	1494855	80211-943-023
Tool box band	1	1304401	80214-943-000
Reflect reflector (KC only)	4	0640573	33741-081-601
6 mm plain washer (KC only)	2	0059071	94101-06000
6 mm lock washer (IC only)	2	0058974	94111-06000
6 mm cap nut (KC only)	2	0057885	94021-06000
Throttle caution tag	1	-----	87600-957-0100
Owner's manual	1	1521020	31943610

(

(

(

(

(

(

(

READ THIS READ THIS READ THIS

# HONDA

MODIFICATIONS WHICH YOU HAVE MADE, OR SHOULD MAKE IN THE FUTURE, TO ANY HONDA MOTORCYCLE, SHALL BE DEEMED BY OUR COMPANY TO HAVE BEEN PERFORMED AT YOUR SOLE RISK AND RESPONSIBILITY, AND WITHOUT OUR COMPANY'S OR THE MANUFACTURER'S APPROVAL OR CONSENT, IMPLIED OR EXPRESSED. WE FURTHER DISCLAIM ANY AND ALL LIABILITY, OBLIGATION, OR RESPONSIBILITY FOR ANY DEFECTS OF MODIFIED PARTS OR OF THE MODIFIED MOTORCYCLE, AND FOR ANY CLAIMS, DEMANDS, OR CAUSES OF ACTION FOR DAMAGE TO PROPERTY OR FOR PERSONAL INJURIES RESULTING FROM THE MODIFICATION OF SAID HONDA MOTORCYCLE.

READ THIS READ THIS READ THIS

READ THIS READ THIS READ THIS