

Set-up Instructions

1984 Model ATC 200X



MPD 6168 8308

AMERICAN HONDA MOTOR CO., INC.
100 WEST ALONDRA BOULEVARD, GARDENA, CALIFORNIA 90247

WARNING

WARNING

WARNING

WARNING

SET-UP AND PRE-DELIVERY SERVICE MUST BE PERFORMED BY AN AUTHORIZED HONDA MOTORCYCLE DEALER. Proper set-up and pre-delivery service is essential to rider safety and reliability of the ATC. When a customer takes delivery of his brand new ATC, he expects it to be in excellent running condition. There are few things that will cause greater customer dissatisfaction than poor preparation of a new unit. An error or oversight made by the mechanic assembling and servicing a new unit can easily result in faulty operation, damage to the machine, or even injury to the rider.



NOTE: Right and left are determined from the rider's view.

Date of Issue: 8/83

SET-UP INSTRUCTION REVISED PAGES

Pages Affected

Orig. Issue Date

Rev. Date

1 through 24

8/83

Original

Remove and destroy superseded pages.

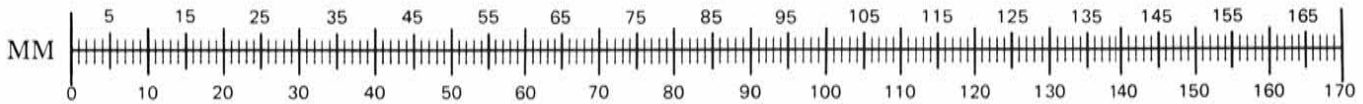

METRIC SCALE FOR DETERMINING BOLT LENGTHS/DIAMETERS

Pay special attention to warnings, cautions, and notes.

WARNING means hazards or unsafe practices which could cause severe personal injury or death.

CAUTION: means hazards or unsafe practices which could cause minor personal injury or product or property damage.

NOTE: gives helpful information.

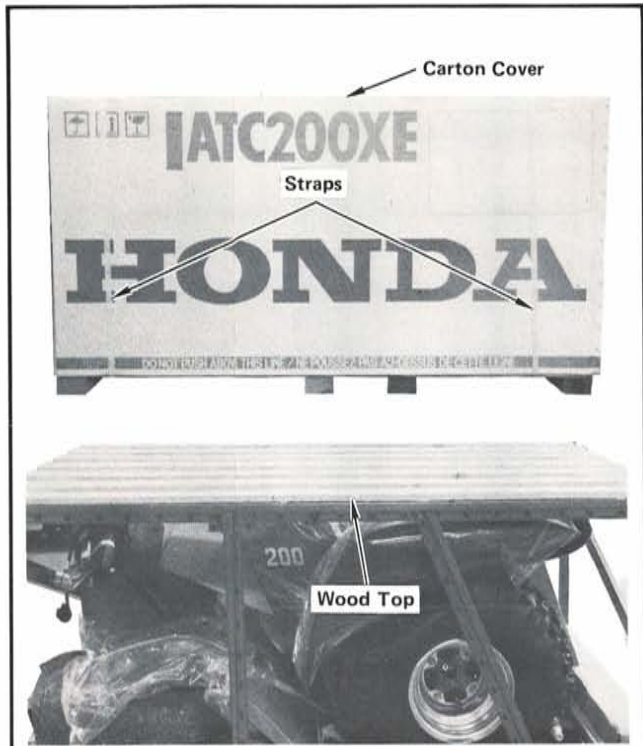

STEP 1—Cut straps and remove carton cover by lifting it up. Remove crate wood top.

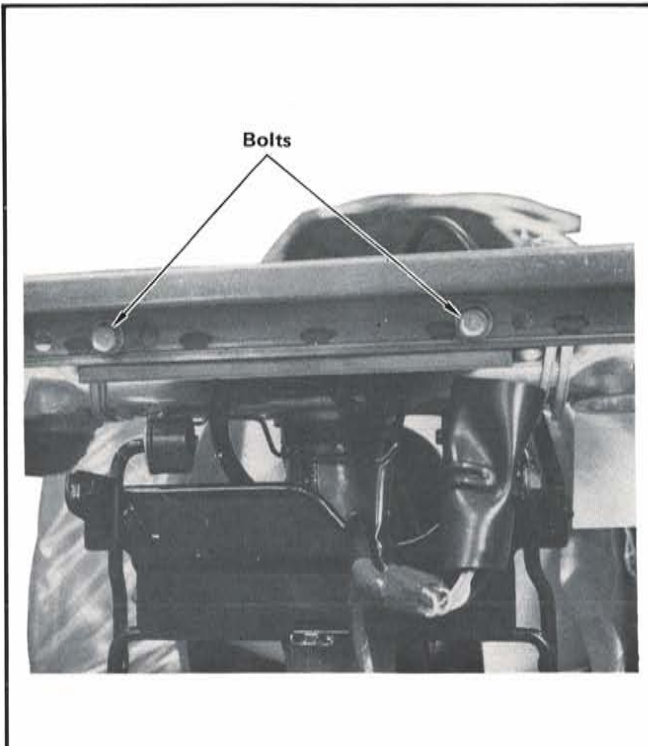

STEP 2—Remove bolts attaching front shipping bracket to crate end frame. Discard bolts.

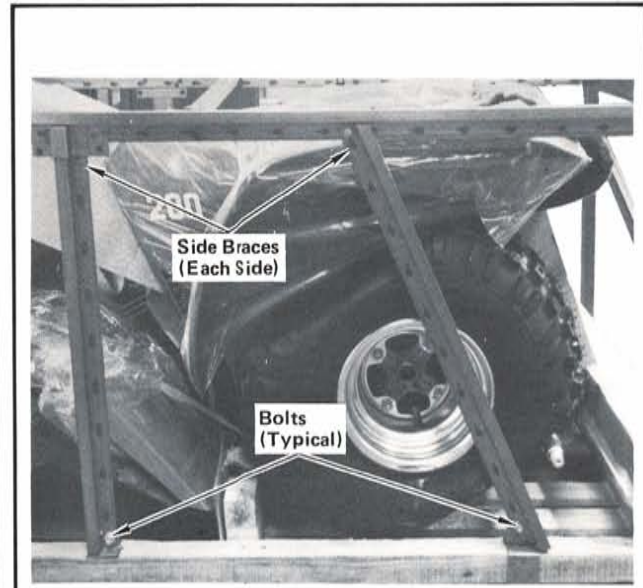

STEP 3—Remove bolts attaching side braces to crate base on each side. Discard side braces and bolts.

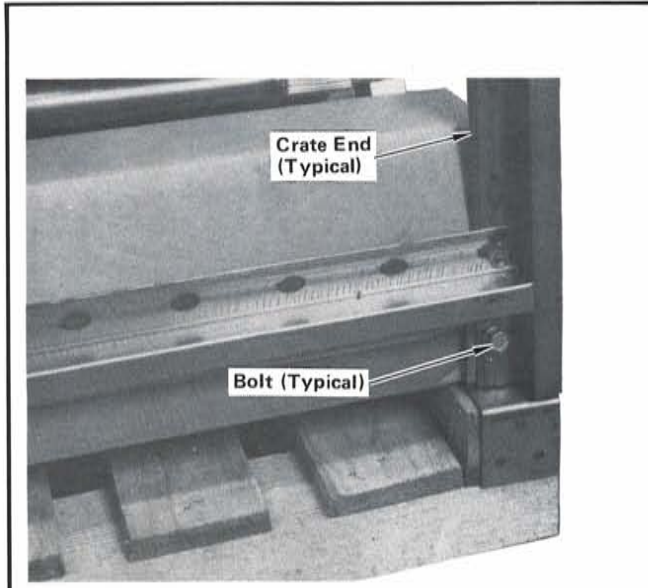

STEP 4—Remove bolts attaching crate ends to crate base. Carefully lift off crate frame using two people. Discard frame and bolts.

CAUTION: Use extreme care not to damage ATC with crate frame.

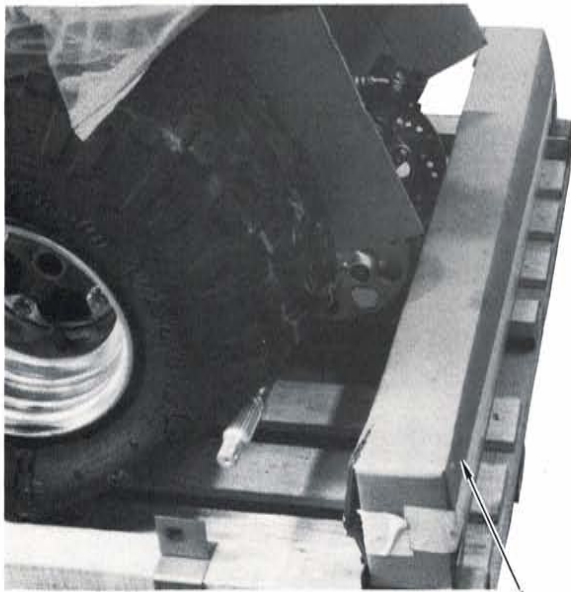

Front Forks Carton

STEP 5—Remove front forks carton from crate base.

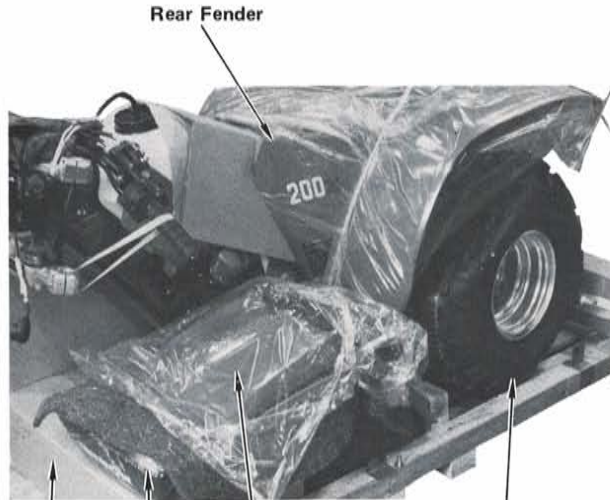

Parts Carton, Seat, Front Fender, Rear Fender, Rear Wheel (Each Side)

STEP 6—Remove rear wheels, rear fender, front fender, seat, front wheel, and parts carton by removing rubber bands and ties.

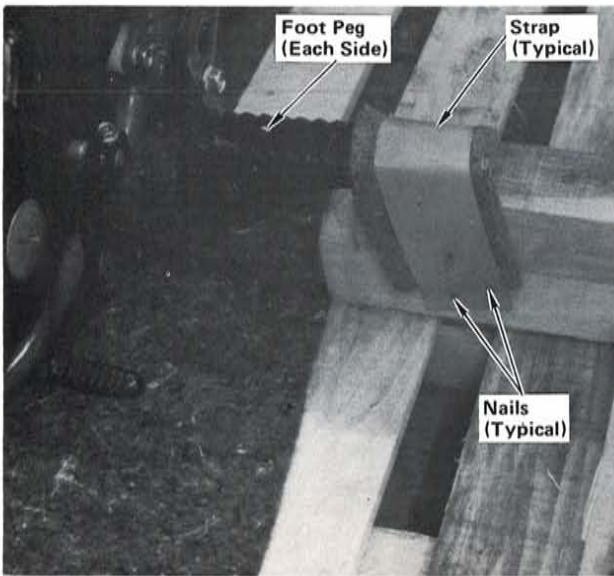

Foot Peg (Each Side), Strap (Typical), Nails (Typical)

STEP 7—Remove nails and remove lower shipping straps holding foot pegs to crate base.

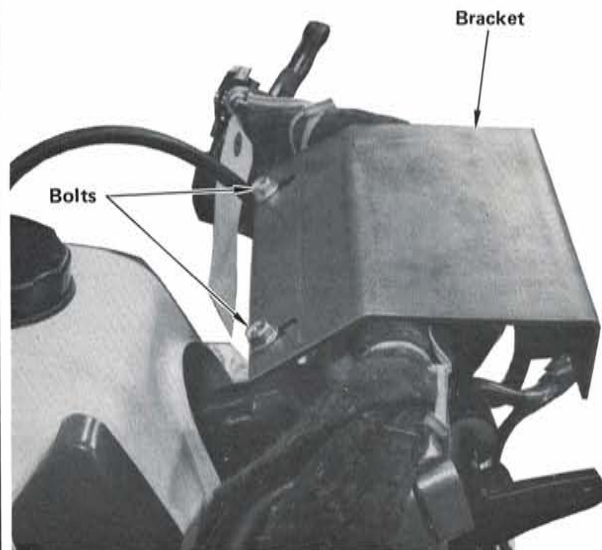

Bracket, Bolts

STEP 8—Remove bolts attaching front shipping bracket to lower handlebar holders. Discard bracket and bolts.



STEP 9—Unpack remaining loose parts and check against this illustration. Report any damaged or missing parts immediately to American Honda Motor Co., Inc., 100 West Alondra Blvd., Gardena, California 90247.

Damaged or Missing Parts

Identify missing parts by referring to the "Loose Parts List" at the end of the set-up. Order parts through normal parts ordering procedures.

It is necessary to differentiate between parts lost or damaged in transit, and parts left out by the factory.

- For parts lost or damaged in transit, file a SHIPPING DAMAGE CLAIM.
- For parts left out by the factory, file a M/C WARRANTY CLAIM SO 908.

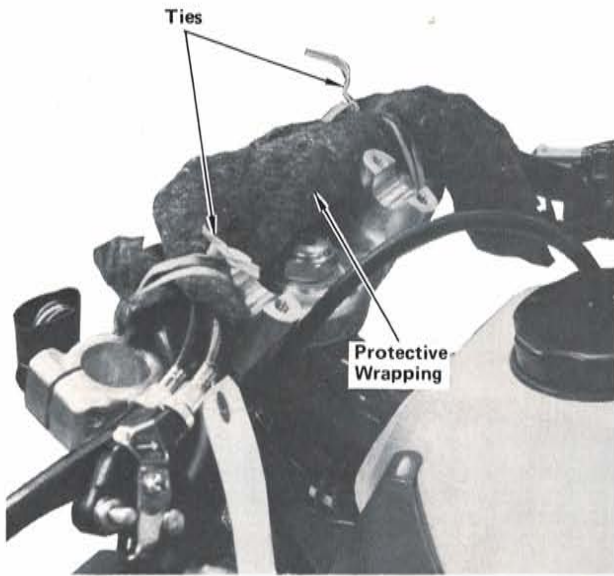

STEP 10—Remove and discard ties and protective wrapping from handlebar.

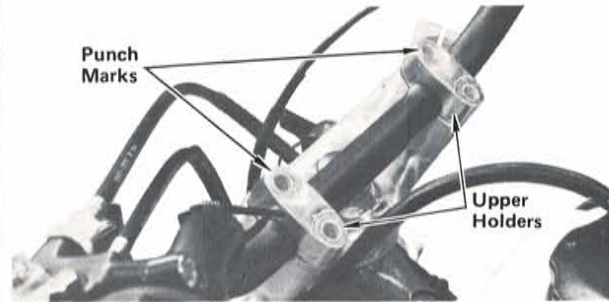
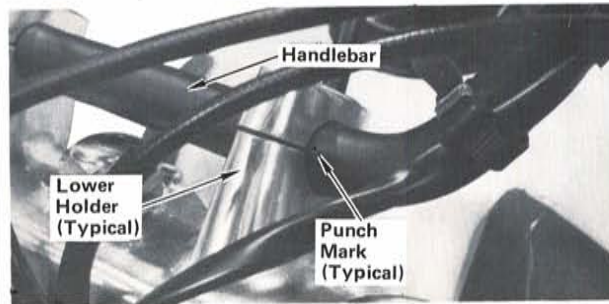

STEP 11—Position handlebar on lower holders with serrations aligned with holders and punch mark on handlebar aligned with top of lower holders. Position upper holders on handlebar as shown, with punch mark on each holder forward.

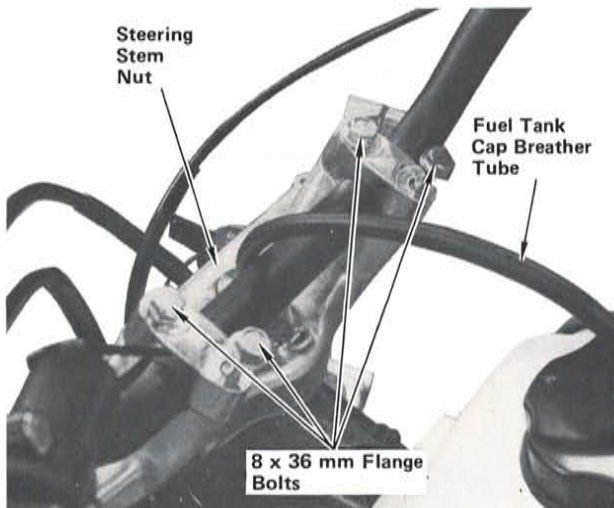

STEP 12—Install upper handlebar holders using two 8 x 36 mm flange bolts for each. Tighten forward bolts to specified torque first, then tighten rear bolts to same torque. Insert fuel cap breather tube into hole in steering stem nut as shown.

Torque specification:
2.7 kg-m (19 lb-ft)

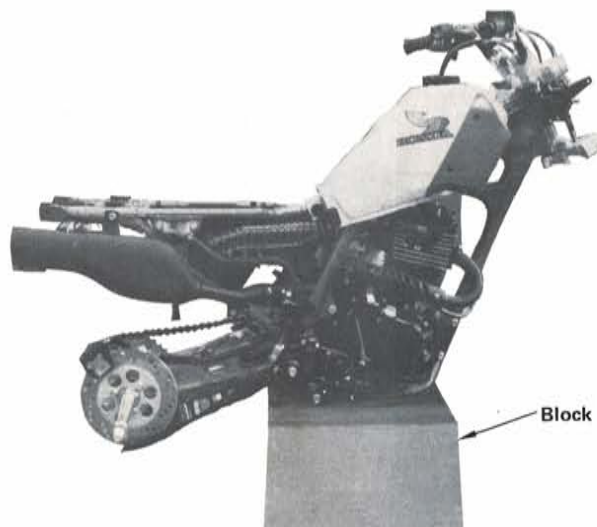

STEP 13—Carefully remove ATC from crate base and support on padded block centered under engine as shown. This will require two people.

CAUTION: The ATC can easily be tipped over until it is resting on the front and rear wheels.

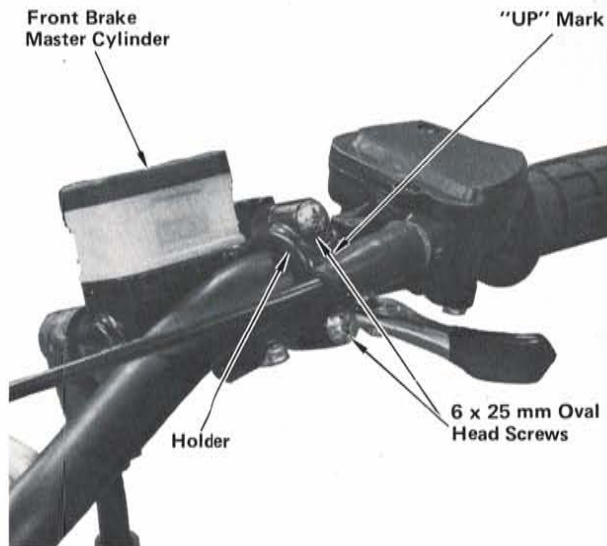

STEP 14—Assemble front brake master cylinder and holder with “UP” mark on holder up. Loosely install holder using two 6 x 25 mm oval head screws.

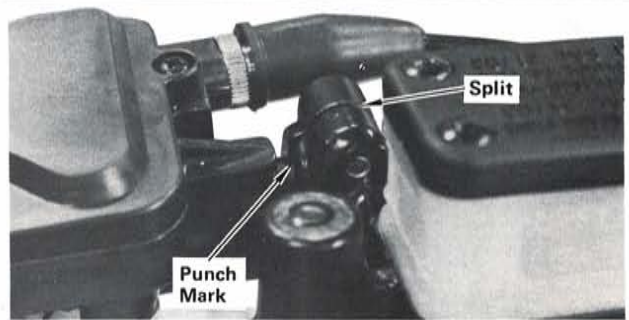

STEP 15—Position master cylinder so split aligns with punch mark on handlebar. Tighten upper screw to specified torque first, then tighten lower screw to same torque.

Torque specification:
0.9 kg-m (7 lb-ft)

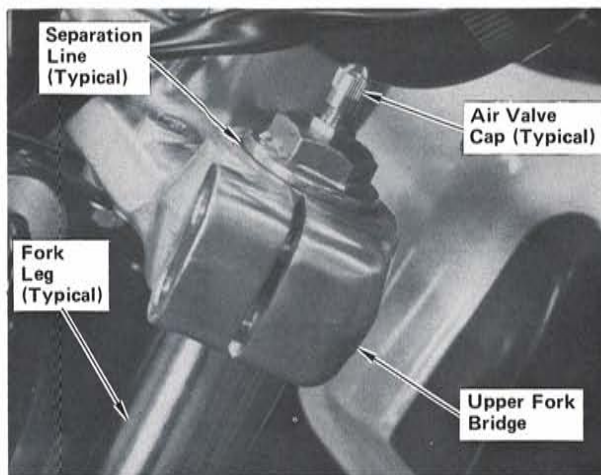

STEP 16—Slide right and left fork legs up through holes in lower and upper fork bridges. (Left fork leg has axle holder.) Position fork legs so that the separation line between the fork bolt and fork tube is even with top of upper fork bridge as shown. Check that fork air valve caps are installed.

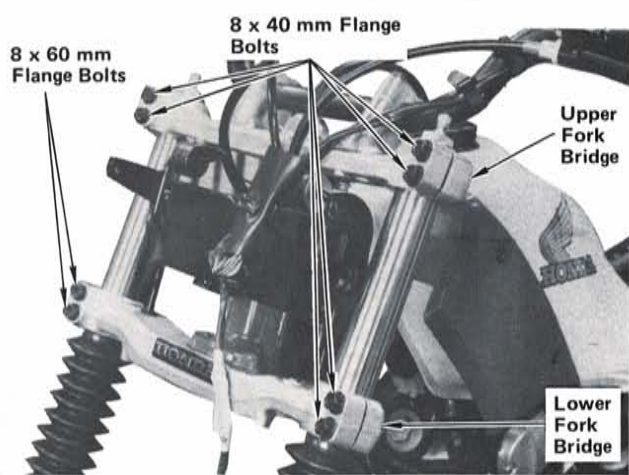

STEP 17—Secure left fork leg using four 8 x 40 mm flange bolts through upper and lower fork bridges. Secure right fork leg using two 8 x 40 mm flange bolts through upper fork bridge, and two 8 x 60 mm flange bolts through lower fork bridge. Tighten upper fork bridge bolts to specified torque first, then tighten bolts in lower fork bridge to same torque.

Torque specification:
2.7 kg-m (19 lb-ft)

Rubber Grommets and Flanged Collars

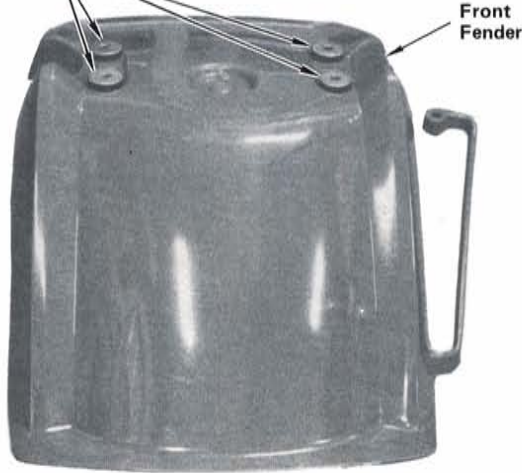

STEP 18—Insert four rubber grommets into holes in front fender. Insert four flanged collars into grommets from the top as shown.

Front Fender

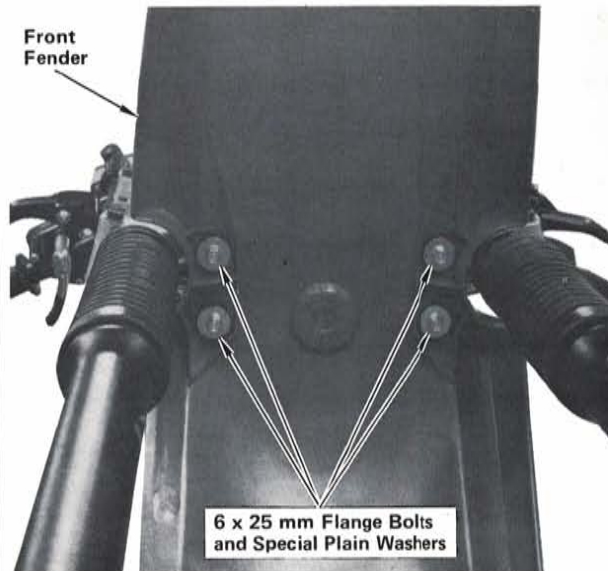

STEP 19—Position front fender between fork legs and install using four 6 x 25 mm flange bolts and special plain washers. Tighten bolts to specified torque.

Torque specification:
1.0 kg-m (8 lb-ft)



STEP 20—Inflate all three tires to specified tire pressure.

Tire pressure: Front: 3.3 psi.
Rear: 2.4 psi.

NOTE: Some pressure will be lost when checking tire pressure with a gauge.

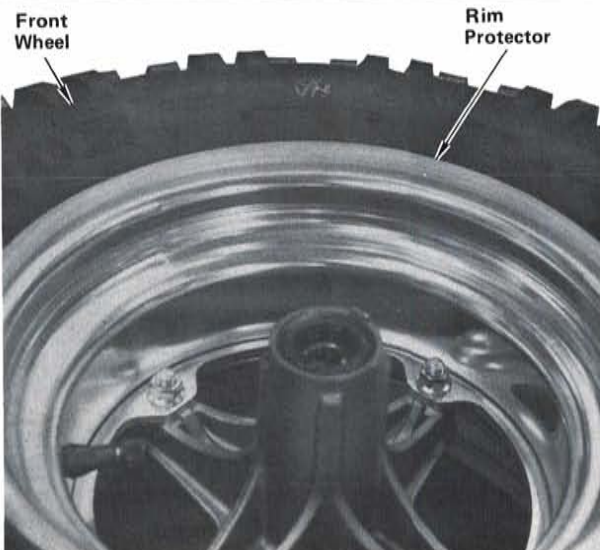

STEP 21—Remove rim protector from front wheel.

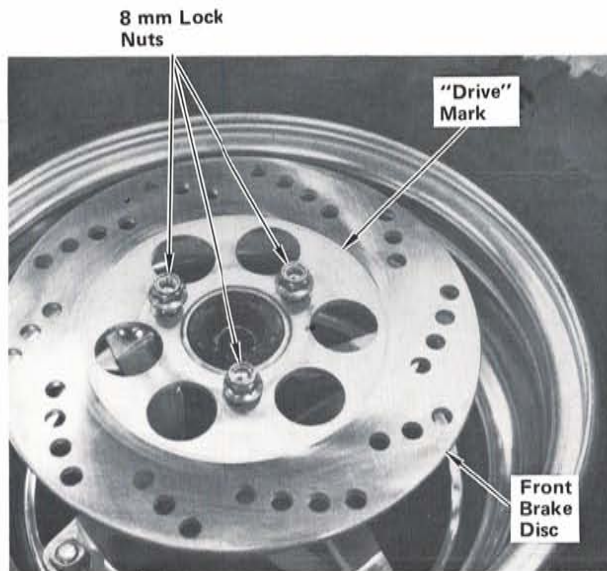

STEP 22—Position front brake disc on studs of front wheel with "DRIVE" mark side facing the outside. Loosely install brake disc using three 8 mm lock nuts. Do not tighten nuts at this time.

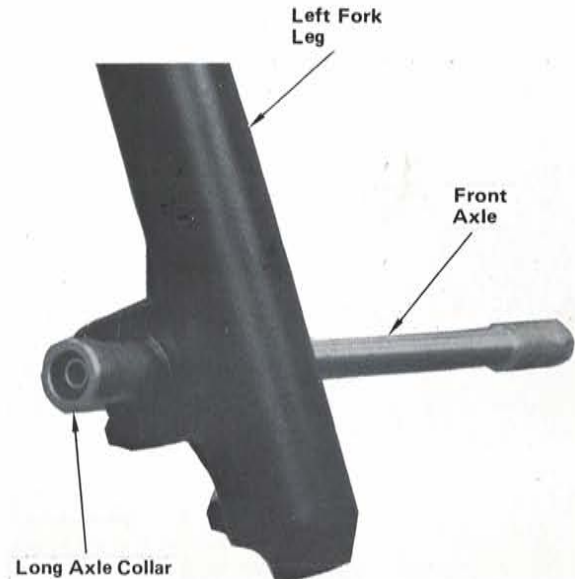

STEP 23—Insert front axle from left side, through left fork leg and long axle collar as shown.

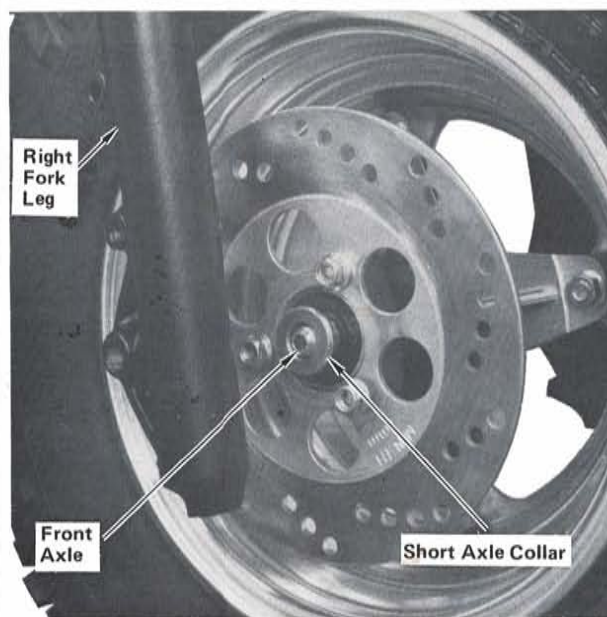

STEP 24—Position front wheel between fork legs with brake disc on the right as shown. Insert front axle through wheel hub and short axle collar, and screw axle into right fork leg.

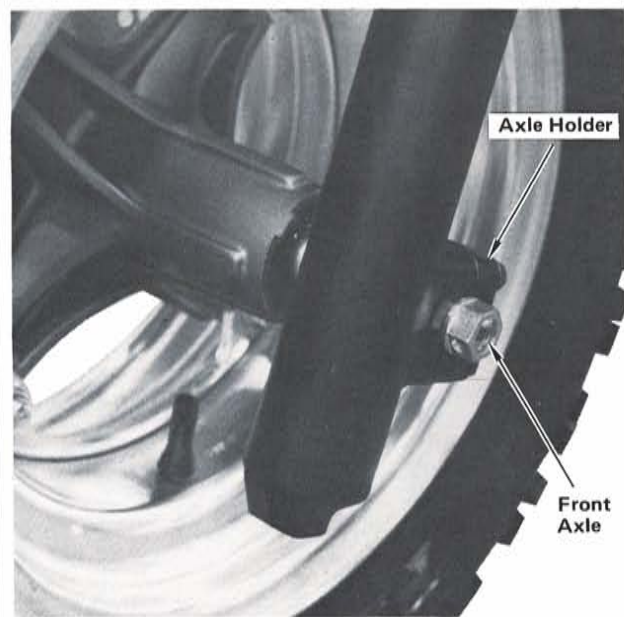

STEP 25—Tighten front axle to specified torque and position left fork leg so axle holder face is flush with flange of front axle.

Torque specification:
9.0 kg-m (70 lb-ft)

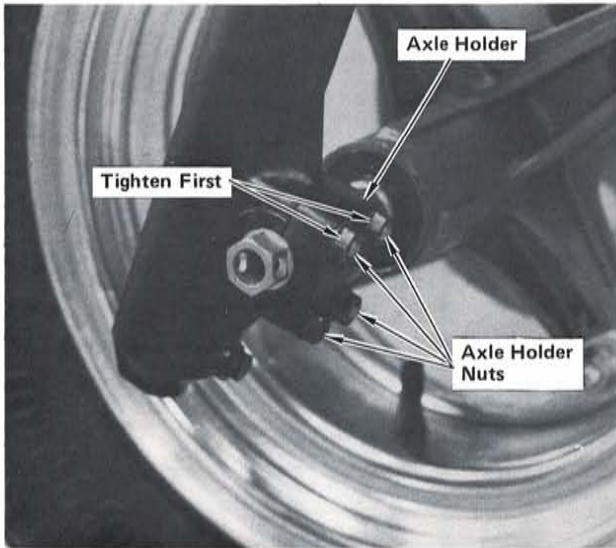

STEP 26—Tighten upper axle holder nuts to specified torque first, then tighten lower nuts to same torque.

Torque specification:
1.2 kg-m (9 lb-ft)

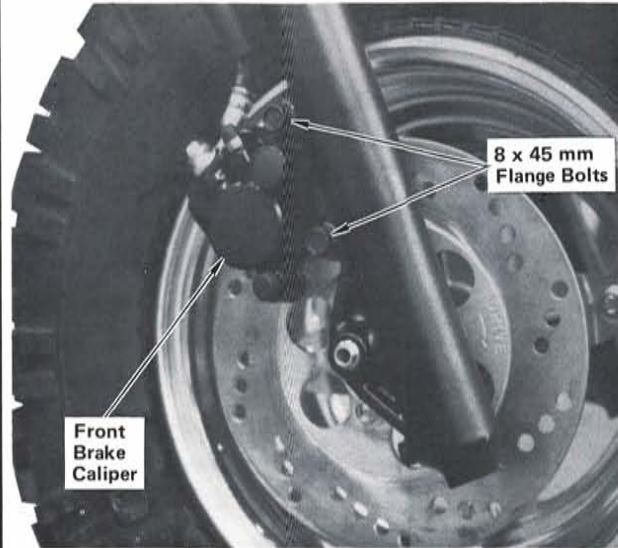

STEP 27—Carefully insert front brake disc between brake pads of front brake caliper. Install front brake caliper on right fork leg using two 8 x 45 mm flange bolts. Tighten bolts to specified torque.

Torque specification:
2.7 kg-m (19 lb-ft)

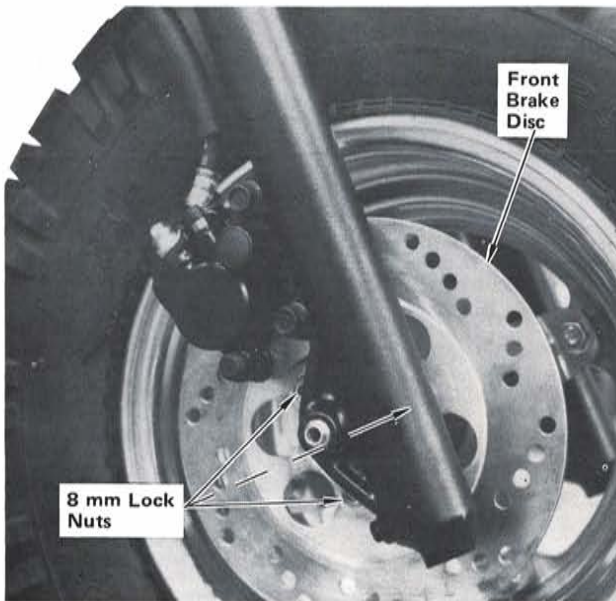

STEP 28—Tighten front brake disc 8 mm lock nuts to specified torque.

Torque specification:
2.7 kg-m (19 lb-ft)

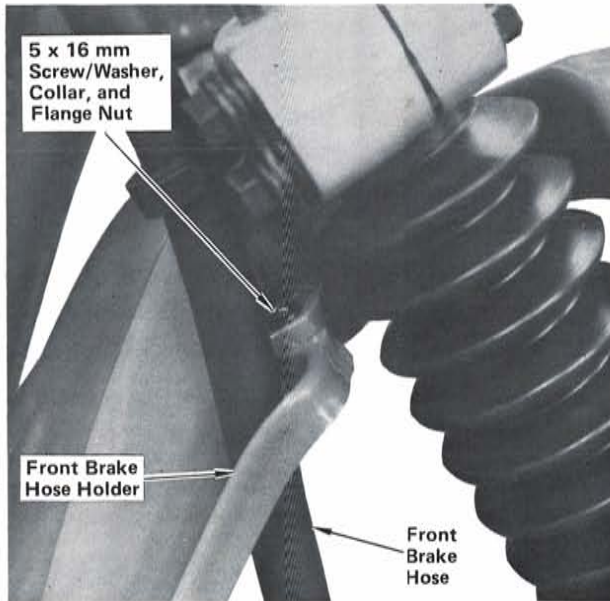

STEP 29—Route front brake hose through brake hose holder on front fender as shown and secure with a 5 x 16 mm screw/washer, collar, and flange nut as shown. Tighten nut securely.

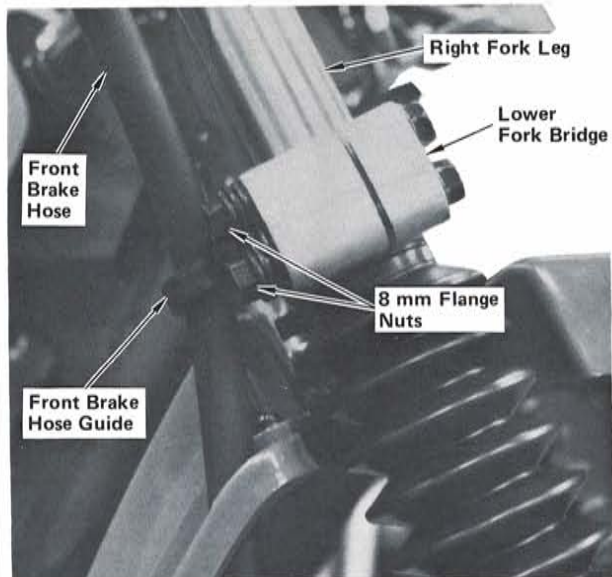

STEP 30—Install front brake hose guide on lower fork bridge as shown using two 8 mm flange nuts. Tighten nuts to specified torque.

Torque specification:
2.7 kg-m (19 lb-ft)

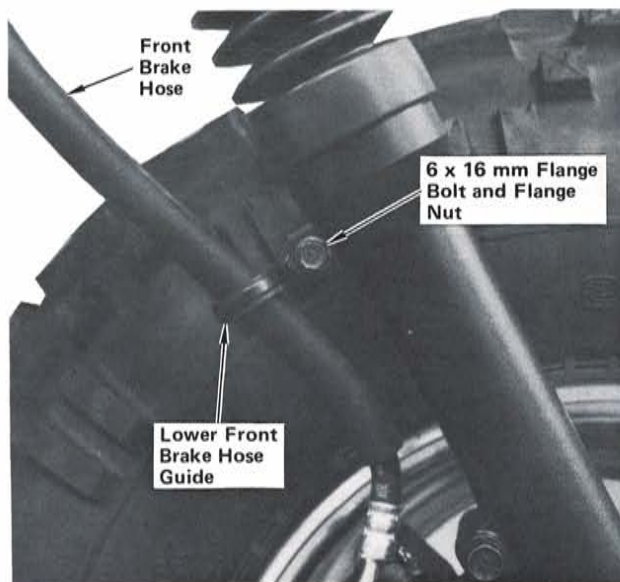

STEP 31—Install lower front brake hose guide on fork leg as shown using a 6 x 16 mm flange bolt and flange nut. Tighten nut to specified torque.

Torque specification:
1.2 kg-m (9 lb-ft)

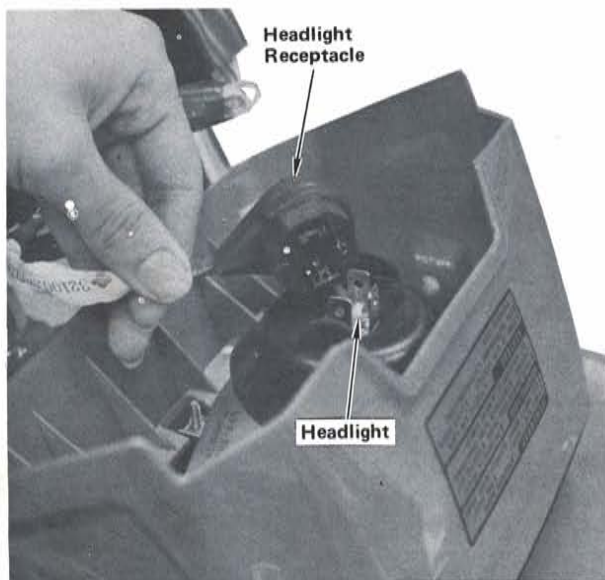

STEP 32—Connect headlight receptacle to headlight.

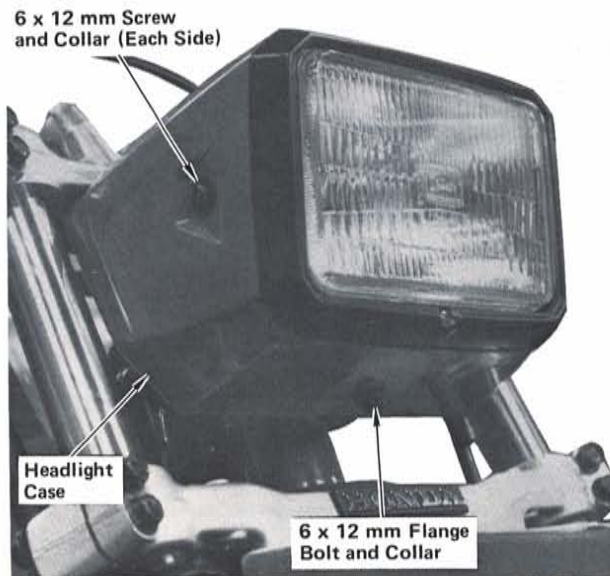

STEP 33—Position headlight case over headlight mount brackets and install using a 6 x 12 mm screw and collar on each side and a 6 x 12 mm flange bolt and collar up through the bottom. Tighten all screws and bolt securely.

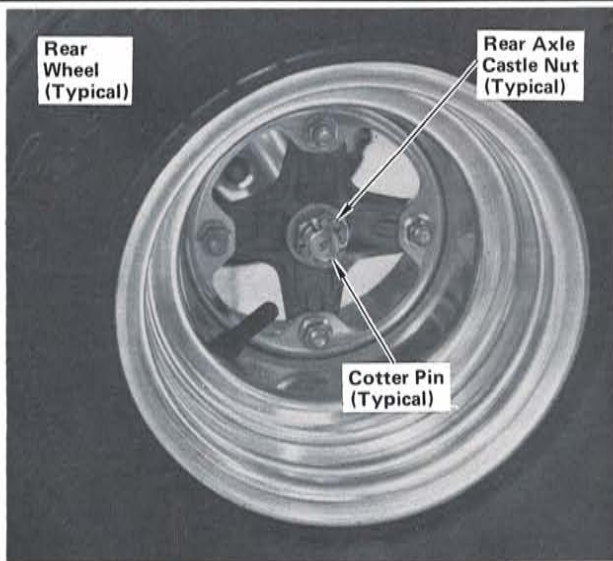

STEP 34—Grease rear axle splines and install rear wheels, with valve stems to the outside, using a plain washer and castle nut for each. Tighten both castle nuts to specified torque and install a cotter pin in each. Spread ends of cotter pins as shown.

Torque specification:
9.0 kg-m (70 lb-ft)

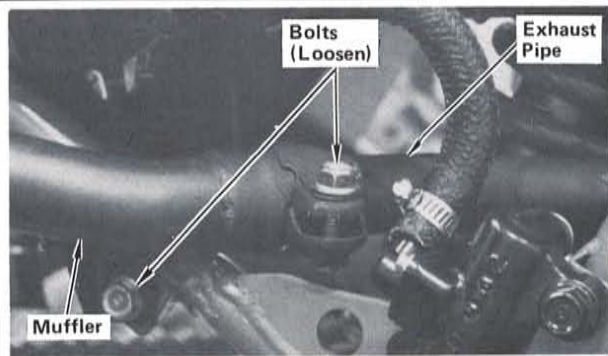

STEP 35—Loosen bolts attaching muffler to exhaust pipe and frame. Remove bolt and special washer attaching muffler tab to frame. Retain bolt and special washer for reinstallation.

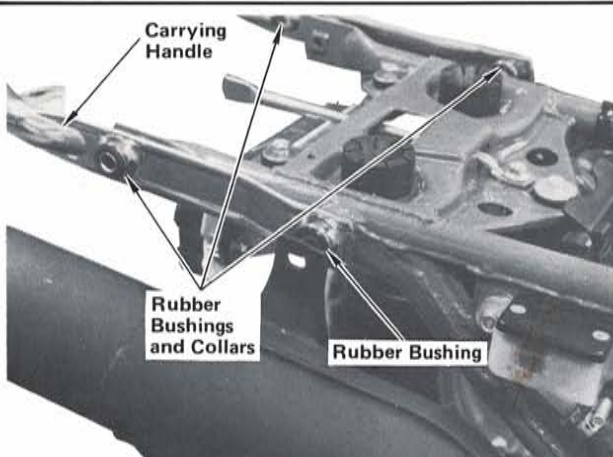

STEP 36—Position carrying handle on rear of frame with curved end up. Insert four rubber bushings into holes in carrying handle. Insert three collars in indicated rubber bushings. (Rubber bushing at muffler attach point does not get a collar.)



STEP 37—Install right side of carrying handle using an 8 x 35 mm flange bolt and 8 mm special washer in rear hole, and an 8 mm special washer between muffler tab and carrying handle, and the bolt retained in Step 35 through muffler, 8 mm special washer, carrying handle, and into frame. Tighten bolts to specified torque.

Torque specification.
2.7 kg-m (19 lb-ft)

Securely tighten bolts attaching muffler to exhaust pipe and frame.

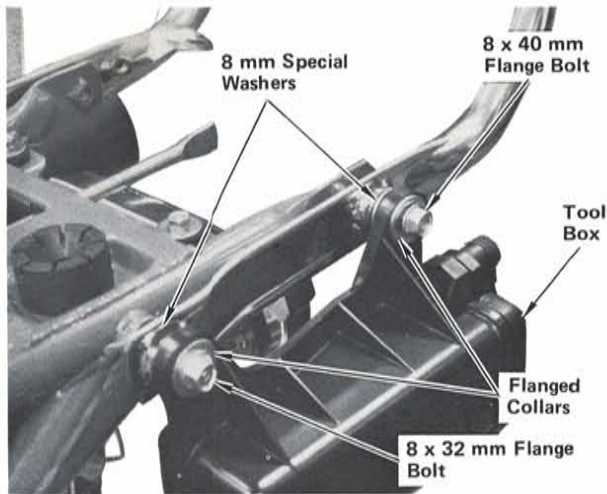

STEP 38—Install tool box on left side, positioned as shown, using an 8 mm special washer between tool box tabs and carrying handle. Insert an 8 x 32 mm flange bolt and flanged collar through forward tab and an 8 x 40 mm flange bolt and flanged collar through rear tab. Tighten bolts to specified torque.

Torque specification:
2.7 kg-m (19 lb-ft)

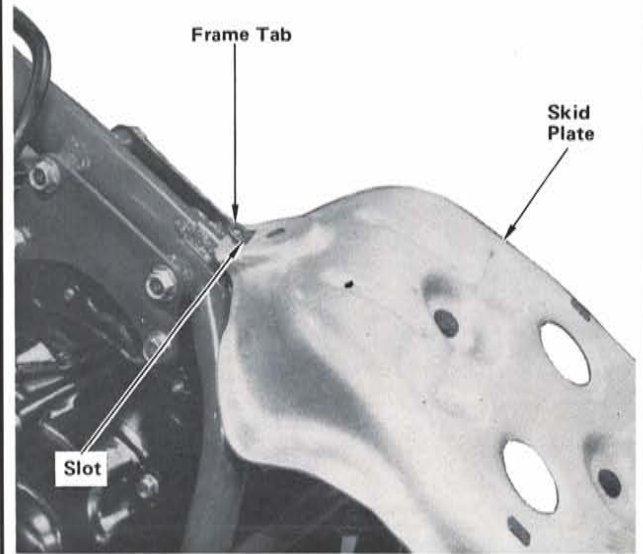

STEP 39—Hook tab on front of frame into slot in front of skid plate.

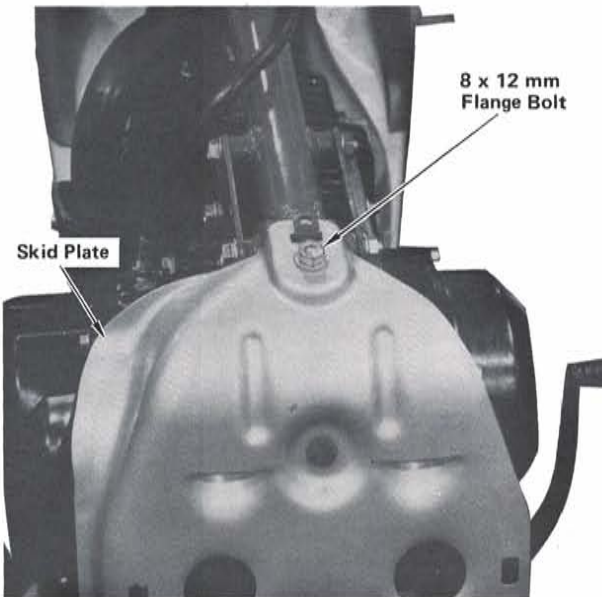

STEP 40—Install front of skid plate using an 8 x 12 mm flange bolt. Tighten bolt to specified torque.

Torque specification:
2.7 kg-m (19 lb-ft)

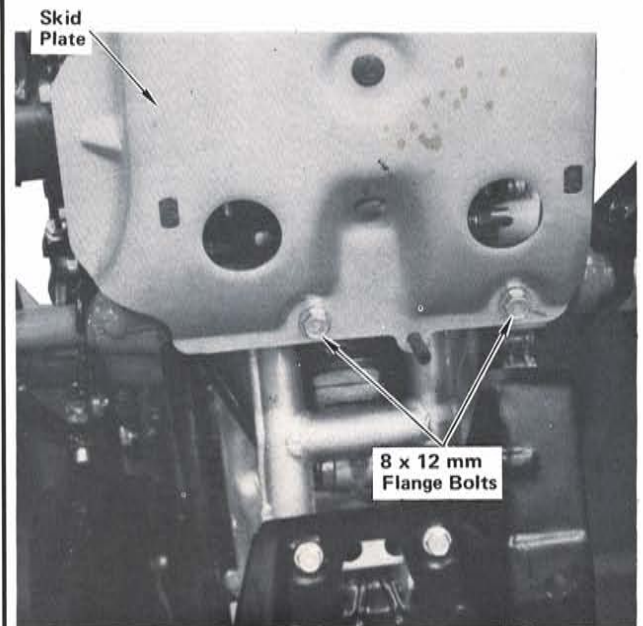

STEP 41—Install rear of skid plate using two 8 x 12 mm flange bolts. Tighten bolts to specified torque.

Torque specification:
2.7 kg-m (19 lb-ft)

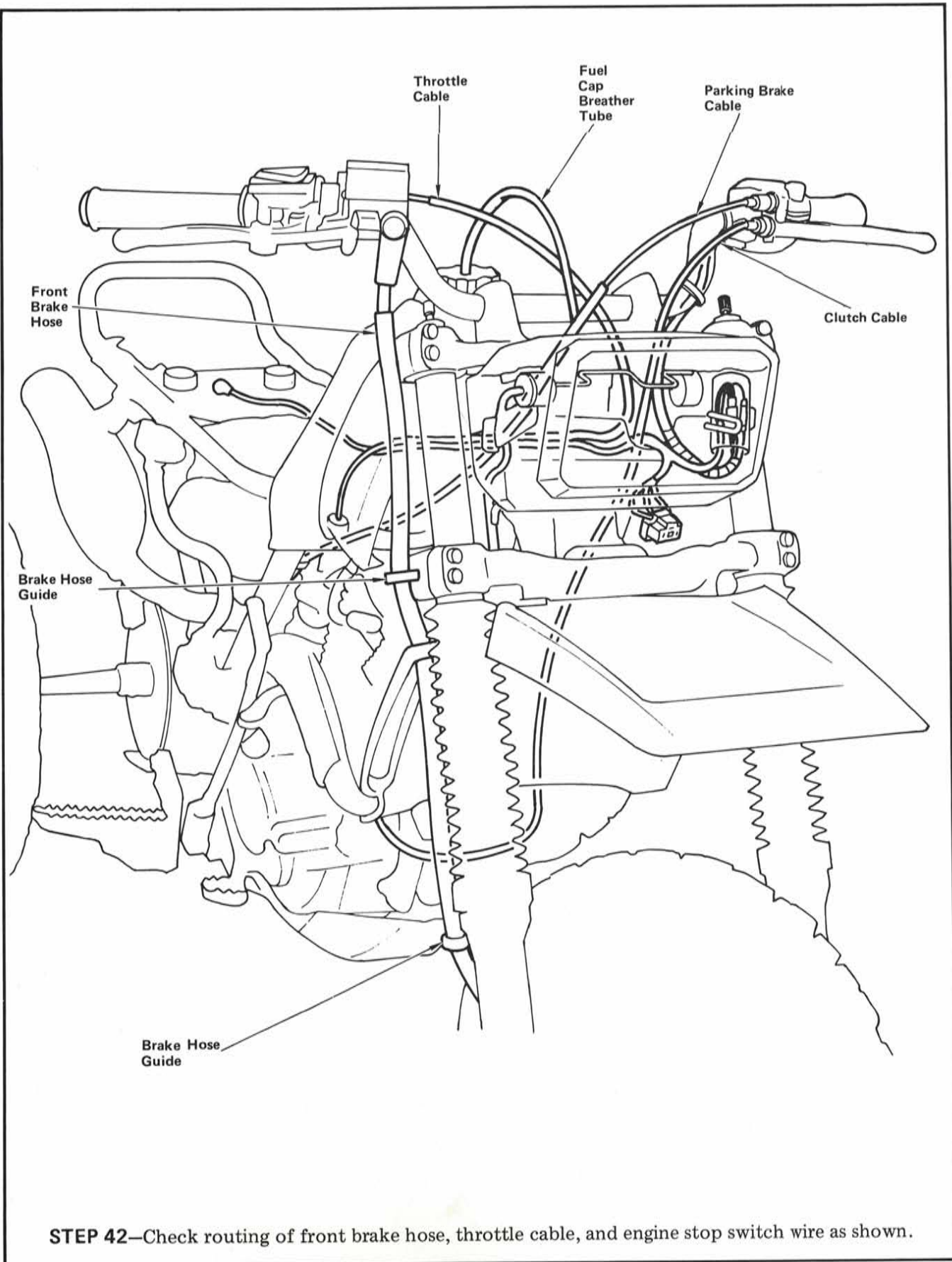

STEP 42—Check routing of front brake hose, throttle cable, and engine stop switch wire as shown.

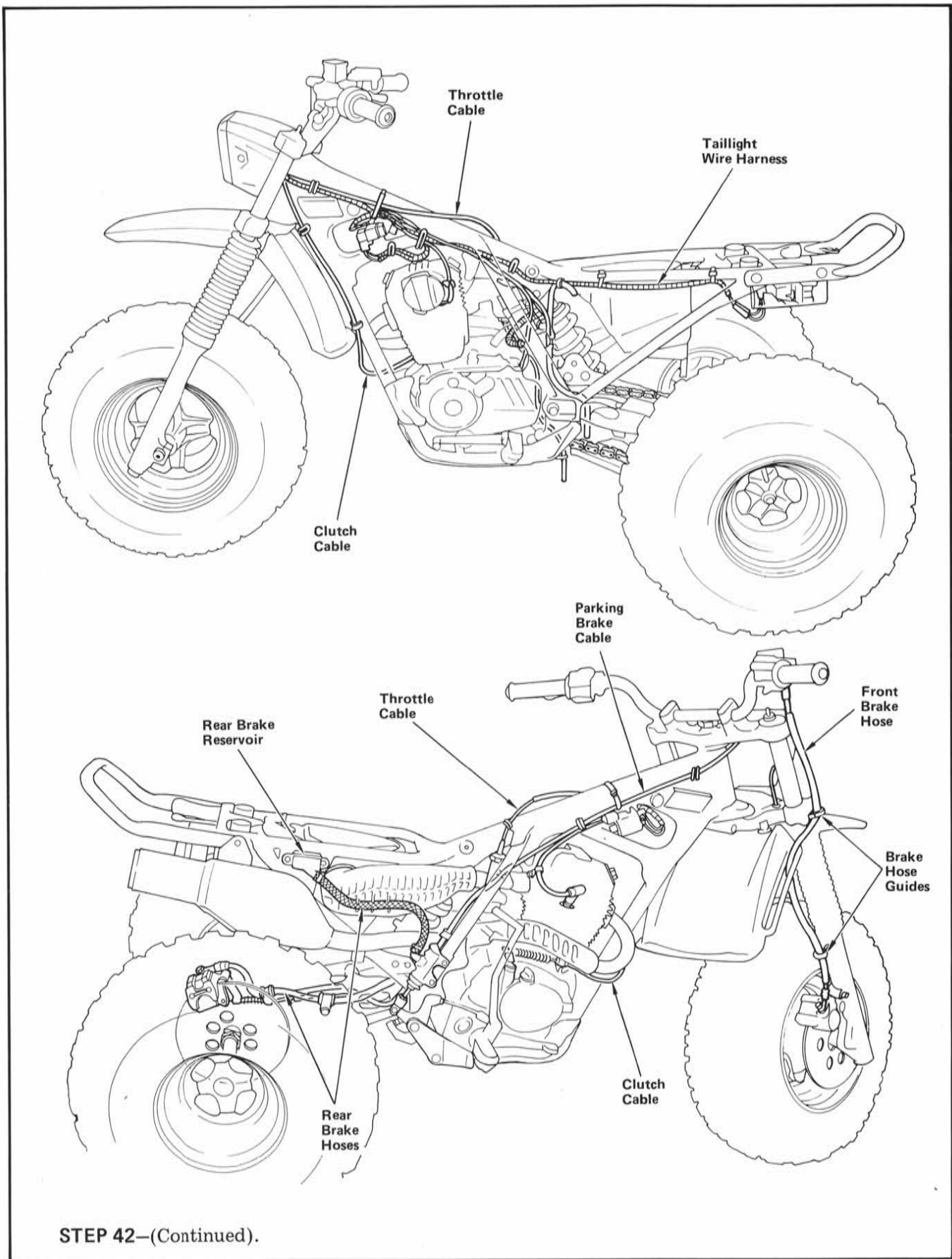

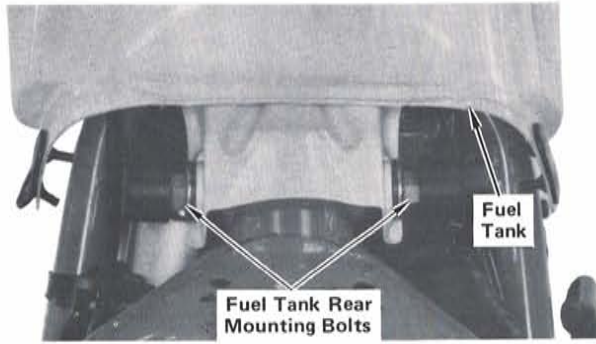

STEP 43—Drain fuel tank as described in shop manual. Remove fuel tank by removing mounting bolts at rear of tank and disconnecting fuel line. Inspect and flush fuel tank. Reinstall fuel tank, connect fuel line, fill tank, turn on fuel petcock and check for leaks and flow through fuel filter. Tighten mounting bolts securely. Check that end of fuel cap breather tube is in hole in steering stem nut. Drain residual fuel from carburetor.

WARNING Fuel must be drained into a proper container. Gasoline is flammable and explosive under certain conditions. Do not smoke or allow flames or sparks near while draining fuel.



STEP 44—Remove oil filler cap/dipstick and fill crankcase with recommended oil as described in owner's manual or shop manual. Reinstall and tighten oil filler cap/dipstick.

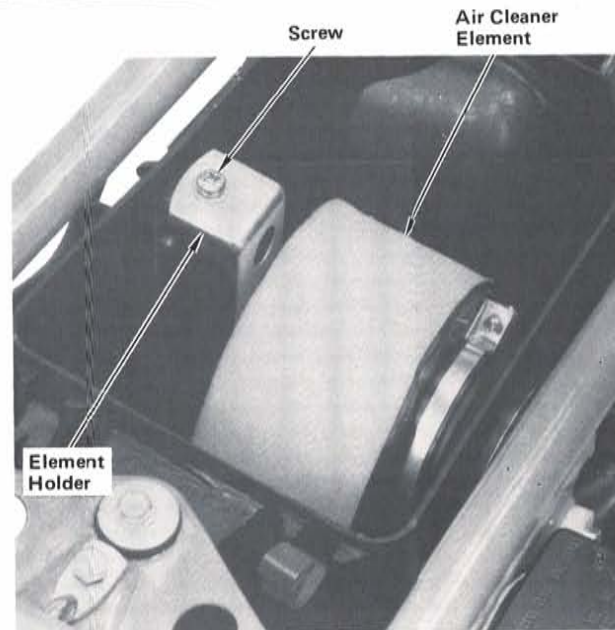
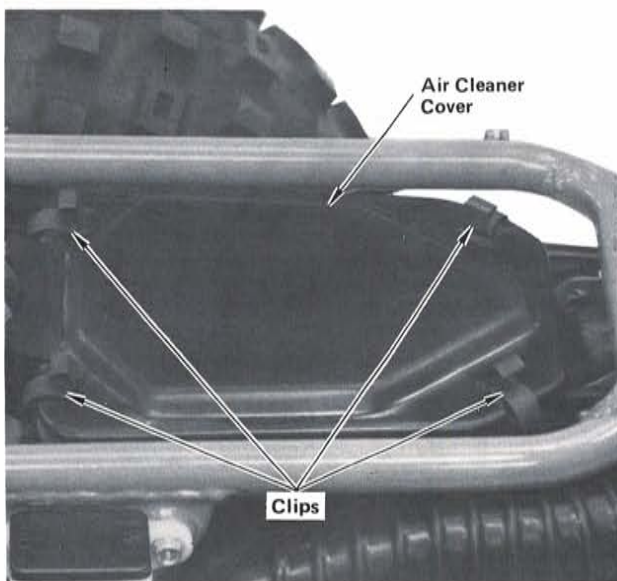

STEP 45—Remove air cleaner cover by releasing four clips. Remove air cleaner element holder by removing screw. Check air cleaner element condition. If necessary, clean and oil element as described in owner's manual or shop manual. Reinstall air cleaner element holder and tighten screw securely. Reinstall air cleaner cover and engage clips.

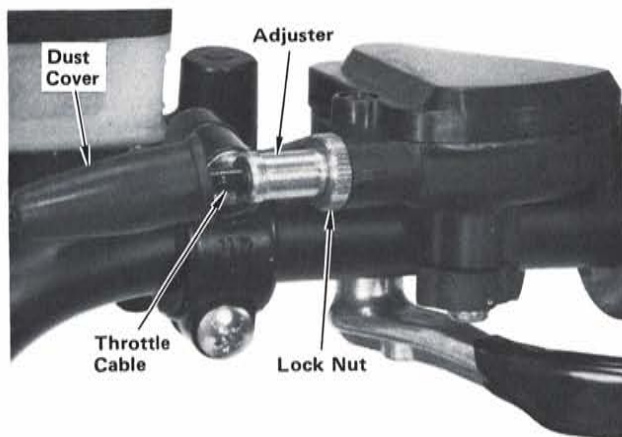
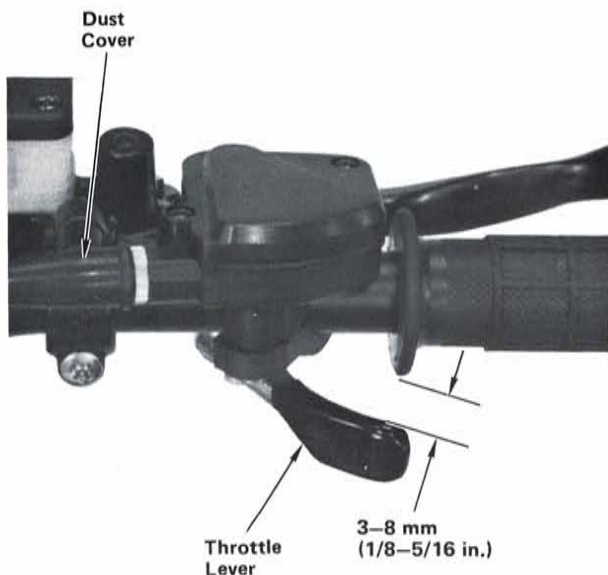

STEP 46—Check throttle cable condition. Check that throttle lever free play is within 3–8 mm (1/8–5/16 in.) at tip of throttle lever. Check for smooth operation of throttle lever from fully open to fully closed in all steering positions and that throttle lever automatically returns from fully open to fully closed when released. If necessary to adjust free play, loosen lock nut and turn adjuster to obtain correct free play. After adjustment, tighten lock nut and reinstall dust cover.

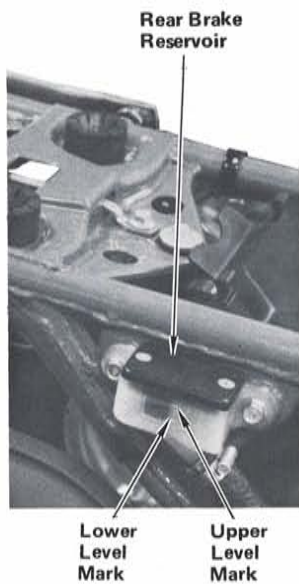
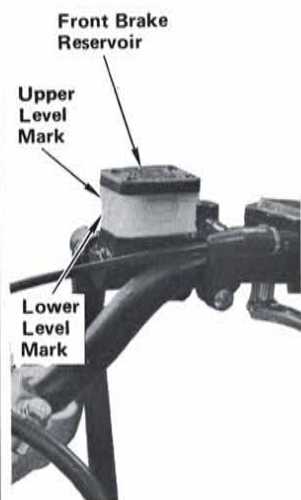

STEP 47—Fill front and rear brake master cylinder reservoirs with DOT 3 brake fluid from a sealed container.

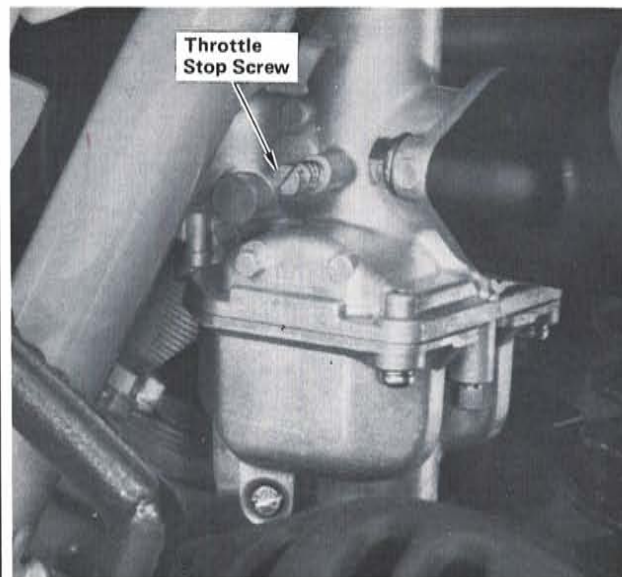

STEP 48—Connect a tachometer and check transmission in neutral. Start engine and allow it to warm up to operating temperature and check idle speed at 1,300 ± 100 rpm. If necessary, adjust idle speed using throttle stop screw. Remove tachometer.

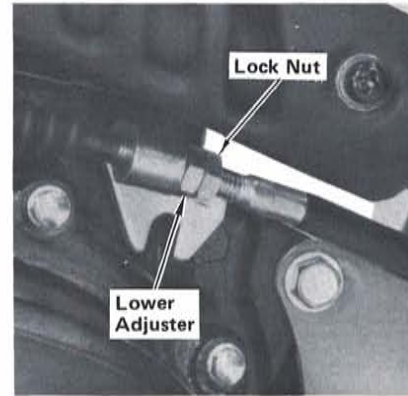
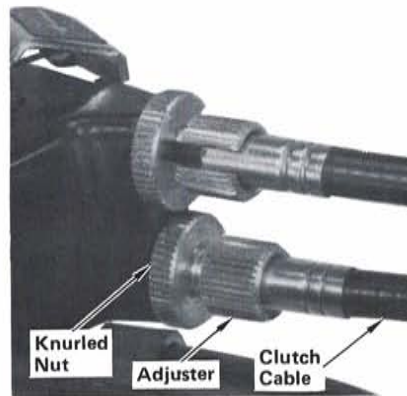
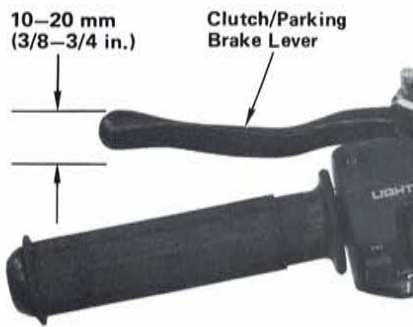

STEP 49—Check clutch lever free play at tip of lever between 10 and 20 mm (3/8–3/4 in.) before clutch starts to disengage. Clutch lever free play can be adjusted at either end of clutch cable. Use lower adjuster to make large adjustments by loosening lock nut and turning lower adjuster. Small adjustments are made at clutch hand lever by loosening knurled nut and turning adjuster. After adjustment, tighten all lock nuts.

CAUTION: After adjusting clutch, check that clutch is not slipping, and is properly disengaging as follows: start engine, pull in clutch lever and shift into gear, and check that engine does not stall or start to creep. Gradually release clutch lever and open throttle, ATC should start smoothly and accelerate gradually.

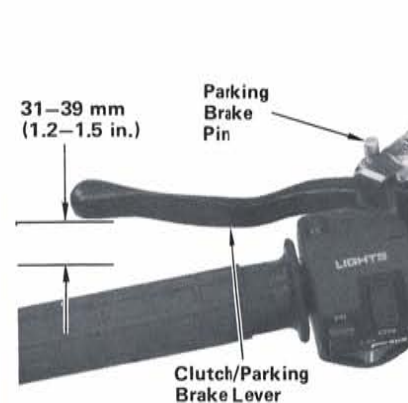
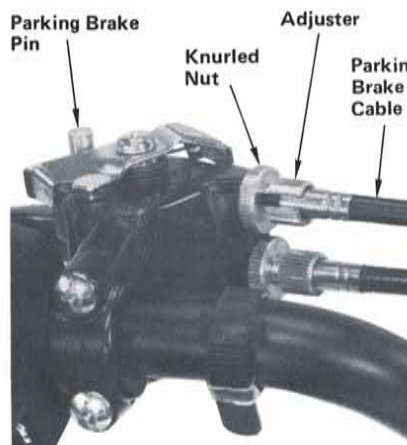
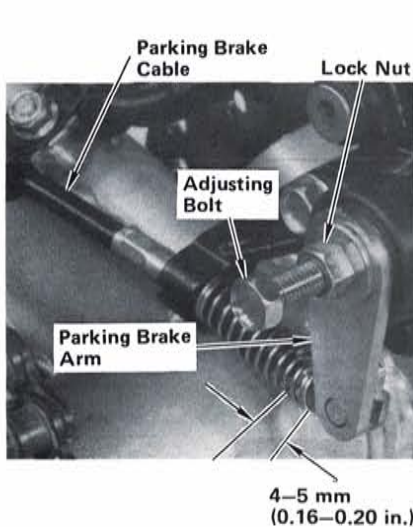

4–5 mm
(0.16–0.20 in.)

STEP 50—Check parking brake operation. Press parking brake pin at rear brake caliper and squeeze clutch/parking brake hand lever to check that free play at tip of parking brake arm at rear brake caliper is within 4–5 mm (0.16–0.20 in.). If necessary, adjust free play as follows: loosen lock nut on rear brake caliper and turn adjusting bolt until resistance is felt without squeezing clutch/parking brake lever. Tighten lock nut. Press parking brake pin and check that travel of clutch/parking brake hand lever is between 31 and 39 mm (1.2–1.5 in.) at tip of lever. If adjustment is necessary, loosen knurled nut, press parking brake pin, squeeze clutch/parking brake lever, and turn adjuster. Tighten lock nut and recheck brake arm free play.

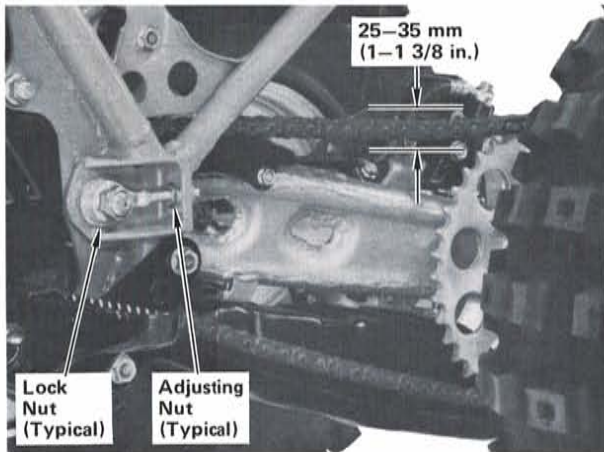

STEP 51—Check drive chain slack and lubrication. If necessary, adjust and lubricate drive chain as described in owner's manual or shop manual.

Slack: 25–35 mm (1–1 3/8 in.)

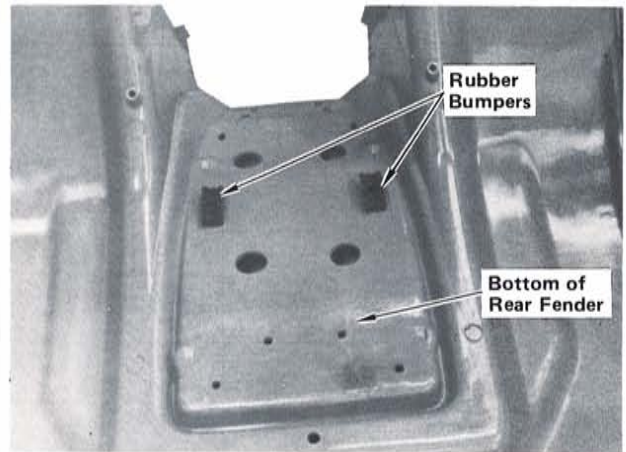

STEP 52—Install rubber bumpers under rear fender where shown. Make sure mounting tips of bumpers are inserted through holes in rear fender and fully engaged.

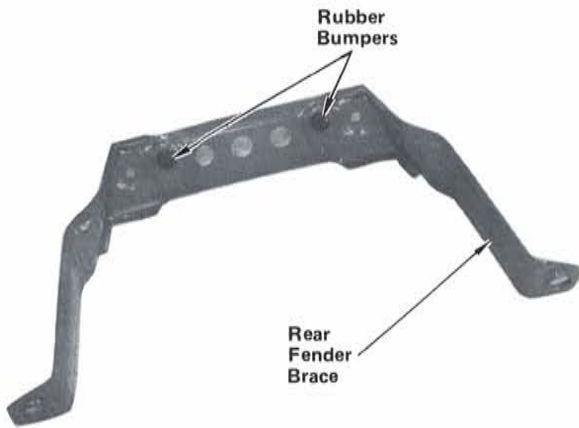

STEP 53—Insert small rubber bumpers into holes in rear fender brace as shown.

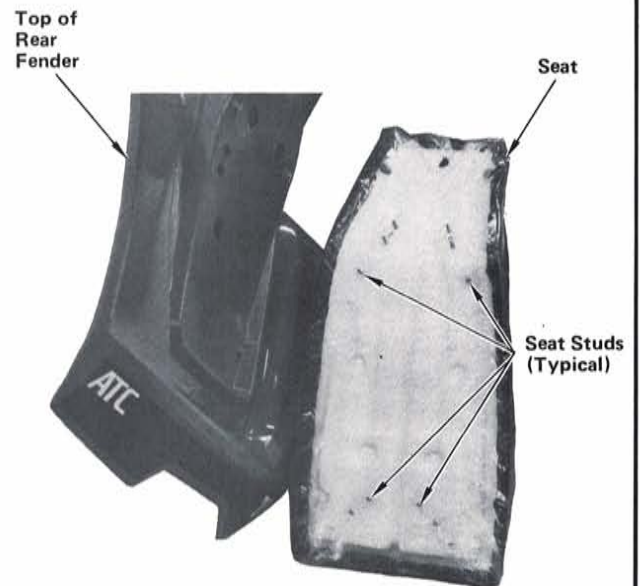

STEP 54—Insert seat studs through matching holes in rear fender.

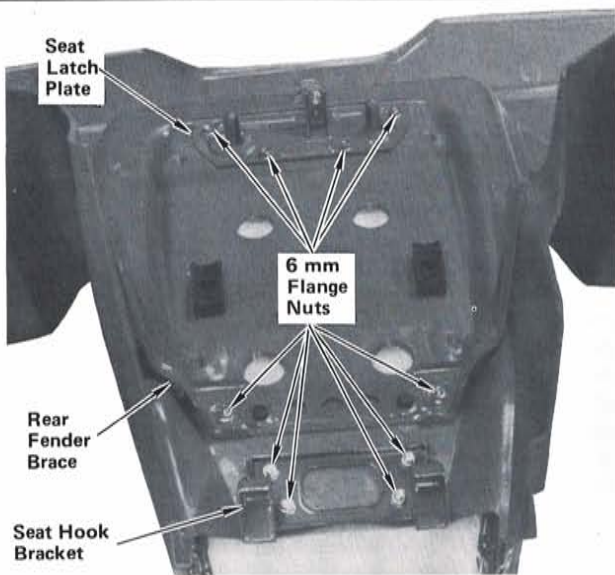

STEP 55—Position seat latch plate, rear fender brace, and seat hook bracket over seat studs as shown. Install seat, and attachments using ten 6 mm flange nuts on seat studs. Tighten nuts to specified torque.

Torque specification:
1.2 kg-m (9 lb-ft)

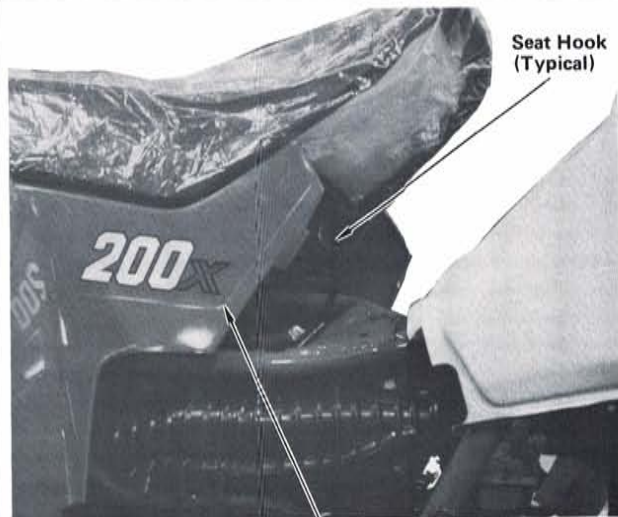

STEP 56—Install seat/rear fender by sliding seat hooks over seat mounts at rear of fuel tank and sliding seat forward. Press down on rear of seat to engage seat latch. Check that seat latch is fully engaged.

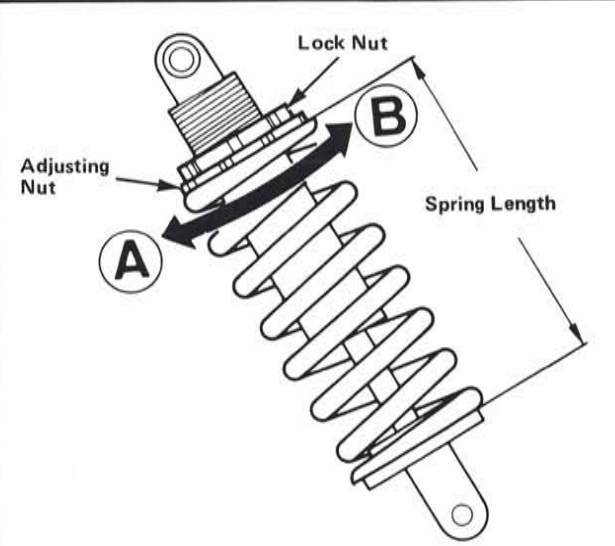

DIRECTION A: SHORTEN SPRING LENGTH
DIRECTION B: INCREASE SPRING LENGTH

STEP 57—Measure rear shock spring length. If necessary to adjust length, loosen lock nut and turn adjusting nut to obtain standard spring length. After adjustment, tighten lock nut.

Standard spring length: 195 mm (7.7 in.).



STEP 58—Remove front fork air valve caps and check front fork air pressure as described in owner's manual or shop manual. Reinstall air valve caps.

Standard air pressure: 0 psi.

TORQUE TABLE

ITEM	SIZE	TORQUE
Handlebar upper holder bolts	8 mm	2.7 kg-m (19 lb-ft)
Master cylinder holder screws	-----	0.9 kg-m (7 lb-ft)
Fork leg bolts	10 mm	2.7 kg-m (19 lb-ft)
Front fender bolts	6 mm	1.0 kg-m (8 lb-ft)
Front axle	-----	9.0 kg-m (70 lb-ft)
Axle holder nuts	-----	1.2 kg-m (9 lb-ft)
Front brake caliper bolts	8 mm	2.7 kg-m (19 lb-ft)
Front brake disc nuts	8 mm	2.7 kg-m (19 lb-ft)
Front brake hose guide nuts	8 mm	2.7 kg-m (19 lb-ft)
Front brake hose guide bolt	6 mm	1.2 kg-m (9 lb-ft)
Rear axle nuts	-----	9.0 kg-m (70 lb-ft)
Carrying handle bolts	8 mm	2.7 kg-m (19 lb-ft)
Skid plate bolts ^s	8 mm	2.7 kg-m (19 lb-ft)
Seat nuts	6 mm	1.2 kg-m (9 lb-ft)

NOTE: Check all items listed on the following Pre-delivery Service Check List. Refer to owner's manual or shop manual for specifications and detailed procedures. Always test ride the unit to make sure that it is functioning properly.

PRE-DELIVERY SERVICE CHECK LIST

- | | |
|---|---|
| <input type="checkbox"/> Fill front and rear brake master cylinder reservoirs with DOT 3 brake fluid. Bleed brake systems if necessary. | <input type="checkbox"/> Inspect electrical components for proper operation and adjustment. <ul style="list-style-type: none"> • Headlight: Adjust. • Taillight. • Ignition switch. |
| <input type="checkbox"/> Adjust parking brake and check cable routing. Check front and rear brake operation and brake hose routing. | <input type="checkbox"/> Check security of all nuts, bolts, and other fasteners. |
| <input type="checkbox"/> Check crankcase oil level. If necessary, fill crankcase with recommended oil. | <input type="checkbox"/> Check to ensure that all applicable recall and product update campaigns are complied with. |
| <input type="checkbox"/> Remove and inspect fuel tank, drain and flush. Clean fuel filter. | <input type="checkbox"/> TEST RIDE: Check performance, handling, and operation. <ul style="list-style-type: none"> • Transmission and clutch: Ease of shifting, clutch operation, etc. • Acceleration: Smoothness, etc. • Cruising: Smoothness, etc. • Handling: Stability and cornering. • Brakes: Smoothness and stopping power. • Idling: Smoothness, throttle response, and return to idle. • Recheck idle speed after 10 minutes of stop and go operation. • Parking brake operation: Check. • Upon completion of test ride, check for fuel and oil leaks. |
| <input type="checkbox"/> Drain residual fuel from carburetor. | |
| <input type="checkbox"/> Check air filter element. Clean and oil if necessary. | |
| <input type="checkbox"/> Adjust clutch, check cable routing and check operation. | |
| <input type="checkbox"/> Reinstall fuel tank, fill, turn on petcock and check for leaks. | |
| <input type="checkbox"/> Adjust idle speed. | |
| <input type="checkbox"/> Check throttle lever free play, cable routing, and operation in all steering positions. | |
| <input type="checkbox"/> Adjust and lubricate drive chain. | |
| <input type="checkbox"/> Check tire pressure. | |
| <input type="checkbox"/> Check front fork air pressure. | |
| <input type="checkbox"/> Check operation and adjustment of front and rear suspension. | |

LOOSE PARTS

The following is a list of items contained in the parts package carton and loose parts in the crate:

PART NAME	QTY	H/C	PART NUMBER
Front wheel	1	-----	44700-965-000
Front axle	1	1403807	44301-965-000
Right front axle side collar	1	1403815	44311-965-000
Left front axle side collar	1	1403823	44312-965-000
Rear wheels	2	-----	42700-965-000
Rear wheel axle nuts	2	0377960	90306-329-770
Cotter pin	2	1047679	94201-40400
Headlight	1	-----	-----
Headlight setting collar	3	0941138	90522-170-700
6 x 12 mm screw oval	2	0671024	93500-06012-0G
6 x 12 mm flange bolt	1	0481176	95700-06012-07
Front brake assy	1	-----	-----
8 x 45 mm flange bolt	2	1226315	95800-08045-07
8 x 60 mm flange bolt	2	1404672	90113-965-000
Rear axle washer	2	1045954	42322-961-000
Brake hose guide	1	1085182	45468-961-000
8 mm flange nut	2	1047463	90303-379-690
Right front fork	1	-----	51400-965-010
Left front fork	1	-----	51500-965-010
Front fender	1	1409481	61100-965-003
Front fender mount rubber	4	0680678	61103-430-000
Front fender mount collar	4	0763946	61104-444-000
25 mm washer	4	1044288	90404-680-000
6 x 25 mm flange bolt	4	0484485	95700-06025-00
Seat	1	1404425	77100-965-003
Rear fender	1	1404441	80100-965-003
Seat lock plate	1	1404466	80102-965-000
Rear fender catch	1	1404458	80101-965-000
6 mm flange nut	8	0612689	94050-06080
Skid plate	1	-----	50360-965-010
8 x 12 mm flange bolt	3	0496455	95700-08012-00
Carrying handle	3	1404474	81200-965-000
8 x 35 mm flange bolt	1	0368639	95700-08035
8 x 40 mm flange bolt	1	0294355	95700-08040
Carrying handle mounting collar	3	1404490	81202-965-000
Carrying handle mounting rubber	4	1404482	81201-965-000
8 mm plain washer	4	0876896	94103-08000
Tool box	1	1406636	83500-965-000
Front brake disc	1	-----	43122-965-000
Tool box collar	2	0686899	83515-428-000
Brake hose guide A	1	0686204	45467-428-000
6 x 16 mm flange bolt	1	1007277	95700-06016-07

LOOSE PARTS (Cont'd)

PART NAME	QTY	H/C	PART NUMBER
6 mm flange nut	1	1089499	90301-428-900
Master cylinder holder	1	1046374	45517-961-000
Upper holder	2	0301713	95014-22100
8 x 36 mm flange bolt	4	0338293	90111-362-000
5 x 16 mm screw/washer	1	0487017	93891-05016-07
Grommet collar	1	0576215	18625-634-670
5 mm hex nut	1	0207399	94002-05000-0S
Hinger stopper rubber	2	1088103	77204-GA6-670
8 x 32 mm flange bolt	1	0637173	95700-08032-00
6 x 25 mm oval screw	2	0420521	93700-06025-0B
8 x 40 mm flange bolts	6	1404698	90118-965-000
8 mm lock nut	3	1001197	90309-428-731
Owner's manual	1	1522036	31965610



READ THIS READ THIS READ THIS

HONDA

Modifications which you have made, or should make in the future, to any Honda product, shall be deemed by our company to have been performed at your sole risk and responsibility, and without our company's or the manufacturer's approval or consent, implied or expressed. We further disclaim any and all liability, obligation, or responsibility for any defects of modified parts or of the modified product, and for any claims, demands, or causes of action for damage to property or for personal injuries resulting from the modification of said Honda product.

READ THIS READ THIS READ THIS

READ THIS READ THIS READ THIS