Honda ATC 70/125

MODEL COVERAGE

ATC 70
ATC 90
ATC 110
ATC 125

Covers 1985 and Earlier

INDEX

Serial Number Locations	2		
MAINTENANCE	2	ENGINE AND TRANSMISSION	9
Lubrication		Engine Removal	9
Checking Engine Oil	2	Top End	9
Chassis Lubrication	3	Right Crankcase Cover	13
Service Checks and Adjustments	3	Left Crankcase Cover	15
Drive Chain	3	Lower End and Transmission	17
Clutch	3	Engine Specifications	18
Throttle Cable	3	Engine Toque Specifications	22
Front Brake	3	General Torque Specifications	23
Rear Brake	4	FUEL SYSTEM	23
Tires	4	Gas Tank	23
Steering Stem Bearings	4	Carburetor	23
Fuel System	4	Fuel Petcock and Lines	24
Air Filter	4	ELECTRICAL SYSTEM	24
Fuel Filter	4	Charging System	25
Carburetor	5	Ignition System	24
Fuel Lines	5	Starting System	25
Spark Arrestor	5	Electrical Switches	26
Periodic Maintenance Intervals	5	CHASSIS	27
Recommended Lubricants	5	Wheels	27
TUNE-UP	6	Front Brake	27
Compression Test	6	Front Wheel Bearings	28
Camshaft Chain	6	Rear Brakes	28
Valve Clearance	6	Front End	29
Ignition Timing	7	Rear Axle	30
Contact Breaker Points	7	Chassis Specifications	31
Carburetor Adjustment	8	Chassis Torque Specifications	31
Tune-Up Specifications	8		

SERIAL NUMBER LOCATIONS

To avoid confusion when ordering parts, always supply the frame and engine serial numbers.

The frame serial number is stamped onto the left side of the steering head lug.

The engine serial number is stamped onto the lower left side of the crankcase behind the gearshift lever.

MAINTENANCE

NOTE: Common maintenance procedures are explained in detail in the "General Information" section of this manual.

LUBRICATION

Checking Oil

1. Oil level should be checked before each ride.
 2. A dipstick is fitted to the oil filler cap on the right crankcase cover.
 3. Park the machine on a level surface.
 4. Start the engine, allow it to idle for several minutes, then shut it off and let it sit for a minute or so.
 5. Unscrew and remove the dipstick and wipe it clean.
 6. Insert the dipstick, allowing the cap to rest on top of the threads of the hole. Do not screw it in when checking oil level.
 7. The oil level should be between the minimum and maximum marks on the dipstick.
 8. If level is too low, add enough oil to bring it up to the specified level.
- CAUTION:** Do not overfill the crankcase.

Changing Oil

1. Oil should be changed every 30 operating days if the machine is used under normal operating conditions.
2. At the same time the oil is changed, the oil filter screen and centrifugal filter should be cleaned. See "Oil Filters," below.
3. Oil should be API service rated "SE" or "SF," SAE 20W-40 or 20W-50 can be used when average air temperature is above freezing (32°F). Refer to the "Recommended Lubricants" chart for all temperature oil recommendations.
4. Run the machine until the engine reaches operating temperature.
5. Park the machine on a level surface.
6. Place a container of about 2 qts. capacity beneath the engine.
7. Remove the dipstick.
8. Remove the oil drain plug. Allow the oil to drain for several minutes.
9. With the ignition or kill switch "OFF," turn the engine over with the recoil starter. This will allow more of the oil to drain out.
10. Check the condition of the drain plug washer. Replace it if damaged.
11. Clean the threads of the drain plug. Install the plug and tighten it securely.
12. Clean the oil filters. See below.
13. Add the correct amount and grade of

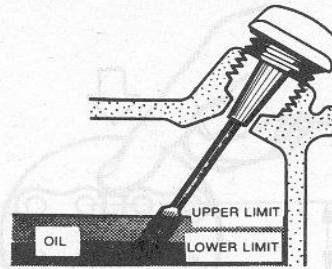

Checking oil level

motor oil. Approximate capacities are as follows. Use the dipstick to check for level:

ATC 70	0.7 qts./0.7L
ATC 90	0.9 qts./0.9L
ATC 110	1.1 qts./1.0L
ATC 125	1.2 qts./1.1L

14. Check oil level as outlined above.
15. Start the engine and let it run for a minute or so. Check for leaks. Recheck level and top up if necessary.

NOTE: The oil change interval is based on normal operating conditions. If the machine is used under severe conditions (i.e. racing, high-speed riding, sto-and-go commercial use, in dusty environments, cold weather, etc.), changes should be made more frequently. This is especially true if the vehicle is used infrequently such as during the winter months.

Oil Filters

1. The machines are fitted with a centrifugal filter in the clutch housing. An oil filter screen is located in a slot beneath the clutch.
2. The filters should be cleaned each time the oil is changed, which will be every 30 operating days under normal conditions.
3. Have a clutch outer cover gasket and a crankcase cover gasket on hand. These items should be replaced.
4. Drain the oil as outlined above.
5. Install the drain plug.
6. Place a drip pan beneath the right crankcase cover.
7. On ATC 70 models, remove the right crankcase cover as follows:
 - a. Remove the exhaust pipe;

- b. Remove the footpegs;
 - c. Remove the carburetor manifold bolts;
 - d. Support the engine with a jack or suitable substitute to take the weight off the upper engine mounting bolt. Remove the bolt;
 - e. Loosen the lower engine mounting bolt;
 - f. Lower the engine;
 - g. Remove the right crankcase cover bolts;
 - h. Remove the right crankcase cover. If it is stuck, tap it with a plastic mallet to free it.
8. On other models, remove the seat. Remove the rear fender.
 9. Remove the starter motor bracket screws, if a starter motor is fitted.
 10. Remove the right crankcase cover screws. Remove the cover. If it is stuck, tap it with a plastic mallet to break it free.
 11. Remove the ball retainer and clutch cam plate side spring.
 12. Remove the oil passage pipe and spring from the center of the clutch.
 13. Remove the clutch cam plate.
 14. Remove the clutch lever.
 15. Remove the clutch outer cover screws. Remove the outer cover and release bearing.
 16. Using a clean, lift-free rag, wipe the center of the clutch housing to remove any foreign matter.
 17. Install the clutch outer cover and bearing. Using a new cover gasket is recommended.
 18. Install the cam plate.
 19. Install the clutch lever.
 20. Clean the oil passage pipe and spring in a clean solvent, dry them, lubricate lightly and re-install.
 21. Install the cam plate side spring and ball retainer, aligning the steel ball with the centerline of the clutch lever.
 22. Remove the oil filter screen from its slot below the clutch.
 23. Clean the screen in a clean solvent to remove any foreign matter.
 24. Check the residue for metal particles. If there are any, it indicates that severe engine wear is taking place. Determine the cause before operating the machine.
 25. If the screen cannot be cleaned, or if it is punctured or shows other signs of damage, replace it.

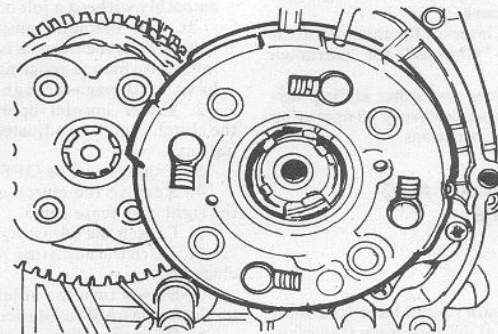

Clutch centrifugal oil filter

Honda ATC 70-125

26. Install the screen.
27. Check that the two locating dowel pins are in place on the crankcase cover mating surface.
28. Install a new crankcase cover gasket.
29. Install the crankcase cover. Tighten the screws gradually and evenly.
30. Add oil as directed under "Changing Oil," above. Check level. Start the engine and check for leaks.
31. After the machine has been sitting for a minute, make a final level check and top up the crankcase if necessary.

Drive Chain

1. The drive chain can be cleaned and lubricated through the inspection cap on the side of the chain case. Some models may be fitted with a lubrication port on the top rear of the case.
2. Standard chains can be lubricated with commercially available chain lubes or with SAE 80 or 90 oil.

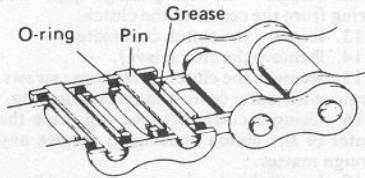

O-ring chain construction

3. Later model ATC 110 and 125 machines are fitted with chains which have rubber O-rings to seal in grease around the pins. These chains should be cleaned only with kerosene. Gasoline and other petroleum-based solvents will damage the O-rings.
4. O-ring chains should be lubricated with SAE 80 or 90 oil or with commercially available chain lubes which are compatible with rubber. Do not use chain lubes unless this is clearly stated on the container.
5. Chain service interval is every 30 operating days.

Chassis Lubrication

1. Chassis lubrication points include wheel and steering head bearings, brake cams and control pivots.
2. Bearings should be lubricated with a good grade of waterproof, medium weight bearing grease. Other points can take general purpose chassis grease.
3. The service interval for these points is every year. See "Chassis" for teardown procedures.
4. Control cables and other sliding surfaces should be lubricated every 30 operating days under normal conditions.

SERVICE CHECKS AND ADJUSTMENTS

Drive Chain

1. The drive chain should have 10-20mm (3/8-3/4 in.) of total up-and-down free-play. This is measured at the chain case inspection hole after removing the rubber cap.
2. Before checking or adjusting the

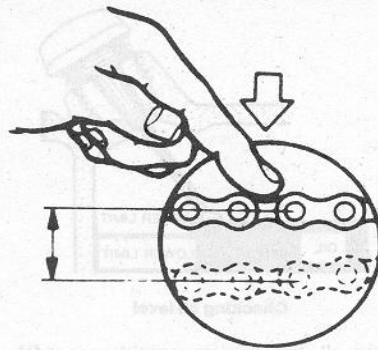

Checking drive chain free-play (10-20 mm/3/8-3/4 in.)

- chain, the following conditions should be met:
- a. The chain should be clean and well lubricated. Dirty chains tend to get tight;
 - b. The chain should have been checked for tight spots by slowly rotating the wheels and checking for variances in tension. If a tight spot exists, the chain free-play should be adjusted to the proper specification at that point. Note, however, that such a condition is indicative of a worn chain and probably worn sprockets which should be inspected and replaced as soon as possible.
 3. Be sure the transmission is in Neutral.
 4. Check chain free-play after removing the chain case inspection hole cap.
 5. On ATC 125 and late ATC 110 machines, adjust the chain as follows:
 - a. Loosen the four rear wheel bearing holder bolts.
 - b. Turn the adjusting nut as required until free-play is correct.
 - c. Tighten the bearing holder bolts. Proper torque is 36-51 ft. lbs.
 - d. Recheck chain free-play.
 - e. Adjust the rear brake.
 6. On early ATC 110 models and 70s and 90s, a chain adjustment mechanism is fitted to the chain case. Loosen the locknut or bolt and move the tensioner so that chain free-play is correct. Then tighten the nut or bolt.

Clutch

1. Clutch operation must meet the following standards:
 - a. The vehicle must go into First gear smoothly without a jolt or stalling;
 - b. The machine must begin to move smoothly as the throttle is opened and moving performance must not indicate power loss and slippage through the clutch.
2. Under normal operating conditions, the clutch should be adjusted every 30 operating days.
3. Engine must be OFF.
4. Remove the clutch adjuster cap from the right crankcase cover.
5. Loosen the adjusting screw locknut.
6. Turn the adjusting screw one full turn clockwise.
7. Slowly turn the adjusting screw counterclockwise until resistance is felt.
8. Back the adjusting screw off 1/8 turn clockwise.
9. Hold the adjusting screw in place and tighten the locknut to 14-18 ft. lbs.

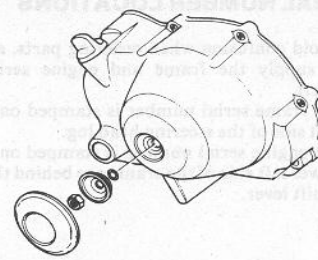

Clutch adjuster

10. Install the cap.
11. Check clutch operation.

Throttle Cable

1. Throttle operation and cable free-play are important safety items which should be attended to without fail. Operation of the throttle should be checked each time before the machine is ridden. The cable adjustment should be checked every 30 operating days.
2. The tip of the throttle lever should move 5-10mm (3/16-3/8 in.) before the throttle slide begins to open.
3. The cable adjuster is fitted to the carburetor end of the cable. Remove the fuel tank and slide back the rubber cover over the adjuster. Loosen the adjuster locknut and turn the adjuster so that cable free-play is correct. Tighten the locknut.
4. On some models, a cable adjuster is fitted to the upper end of the cable as well as to the carburetor end. This adjuster can be used for minor cable adjustments. If two cable adjusters are fitted, use both of them so that neither one approaches the end of its range.
5. With the engine idling, turn the handlebars slowly from lock to lock and listen for any change in engine speed. If this happens, the throttle cable is either too tightly adjusted or is binding somewhere along its routing.
6. Check that the throttle lever returns to the closed position regardless of the position of the handlebars. If it seems to hang up at one point or another, check cable free-play, cable routing and cable and throttle lever lubrication.

Front Brake

1. The tip of the hand lever should have 15-20mm (5/8-3/4 in.) of free movement before the linings contact the drum.
2. Adjust, if necessary, by turning the wing nut at the wheel in until lever free-play is correct.
3. Make minor adjustment, if necessary, with the cable adjuster at the hand lever.

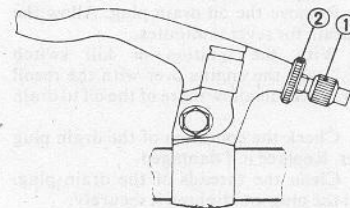

Cable adjuster (1) and locknut (2)

4. Apply the brakes fully and check the wear indicator position relative to the index mark on the brake plate. When the two align, the brake shoes must be replaced.

Rear Brake

ATC 70

1. The tip of the hand lever should have 15-20mm (3/8-3/4 in.) of free movement before the linings contact the drum.

2. Maintain this adjustment with the adjusting nut on the end of the brake rod.

3. Late models are fitted with a wear indicator on the brake plate. If the indicator aligns with the index mark on the brake plate when the brakes are fully applied, the brake shoes must be replaced.

ATC 90/110/125

1. The tip of the rear brake hand lever should have 15-20mm (5/8-3/4 in.) of free movement before the linings contact the drum.

2.-Use the adjuster at the hand lever for minor corrections.

3. Use the adjuster at the foot pedal for major corrections.

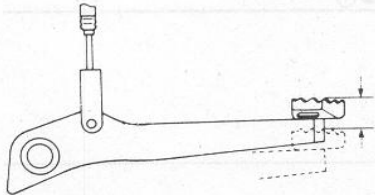

Brake pedal free-play (15-20 mm/5/8-3/4 in.)

4. The foot pedal should have 15-20mm (5/8-3/4 in.) of free movement before the linings contact the drum. This free-play is measured at the tip of the pedal.

5. Use the adjuster on the cable at the brake drum to give the correct pedal travel.

CAUTION: Unless the brake pedal is properly adjusted, the hand lever will not be effective.

6. When the brakes are fully applied, check the wear indicator on the drum. If the index marks align, replace the brake shoes. See "Chassis."

Tires

1. Periodically check each tire for cuts, embedded matter, excessive tread wear.

2. Tire pressures must be checked when the tires are cold. A special low pressure gauge is needed for accurate readings.

3. Proper tire pressures are as follows:

ATC 70

1970-81 3.0psi

1981-On 2.2 psi

ATC 90/110/125 2.2 psi

CAUTION: Always maintain tires at the recommended pressures.

4. If pressure is too low, pump up the tires with a hand-held pump.

CAUTION: Never apply high pressure air sources to the tire valves. Service station hoses are generally unsuitable for filling these low pressure tires.

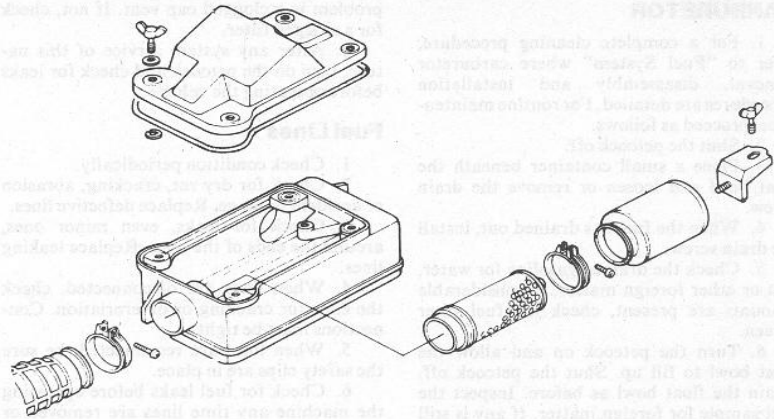

Air cleaner assembly (ATC 125)

Steering Head Bearings

1. Bearing wear and adjustment should be checked periodically.

2. Raise the front end of the machine off the ground by placing a safe, sturdy support beneath the frame.

3. Turn the handlebars slowly from lock to lock.

4. Check for binding, rough rotation and/or bearing noise as the wheel is turned. If any is noted, adjust the bearings as outlined in "Chassis."

5. Grasp the lower end of the forks and attempt to move them back and forth in line with the machine. There must be no play evident. If play is found in the forks, the bearings must be adjusted or replaced. Refer to "Chassis" for procedures.

Non-flammable cleaning solvent

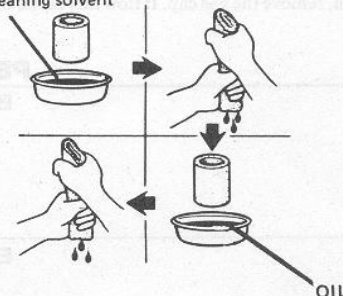

Oiling the air filter element

FUEL SYSTEM

Fuel system maintenance involves cleaning the filter, cleaning or replacing the air filter and cleaning the carburetor. These procedures should be carried out every 30 operating days.

Air Filter

1. Wash the element in a safe, high flash point solvent. Squeeze it to dry thoroughly.

CAUTION: Do not wring the element out as the pores or fabric may be damaged.

2. Soak the element in SAE 80 or 90 gear oil. Squeeze off the excess.

3. Fit the element on the frame and install the assembly in the case.

Fuel Filter

1. The fuel filter is fitted to the carburetor float bowl on some models and behind the petcock on others.

2. Turn the petcock to the off position.

3. Place a rag beneath the carburetor to soak up the small amount of gasoline which will come out.

4. Remove the filter cap from the float bowl or the petcock (two screws).

5. Remove the filter screen.

6. Clean the filter in solvent. If the filter cannot be cleaned or is crushed, punctured or otherwise ineffective, replace it.

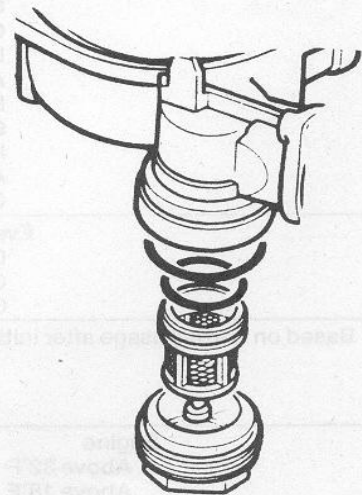

Carburetor float bowl filter

7. If your model has the filter cap, clean the inside of the cap in solvent.

8. Check the condition of the O-ring(s). Replace if knicked, crushed or otherwise damaged, or if leaks are evident.

9. Filter caps should be tightened to 4 ft. lbs.

10. Turn the petcock on and check for leaks before operating the vehicle.

Honda ATC 70-125

CARBURETOR

1. For a complete cleaning procedure, refer to "Fuel System" where carburetor removal, disassembly and installation procedures are detailed. For routine maintenance, proceed as follows.

2. Shut the petcock off.

3. Place a small container beneath the float bowl and loosen or remove the drain screw.

4. When the fuel has drained out, install the drain screw.

5. Check the drained gasoline for water, dirt or other foreign matter. If considerable amounts are present, check the fuel filter screen.

6. Turn the petcock on and allow the float bowl to fill up. Shut the petcock off. Drain the float bowl as before. Inspect the fuel sample for foreign matter. If any is still present, check the fuel filter. Remove the gas tank and drain off the fuel. Check it for dirt and water. Flush out the tank before installing it.

7. If fuel flow out of the bowl seems sluggish, remove the gas cap. If flow increases, the

problem is a clogged cap vent. If not, check for a clogged filter.

8. After any system service of this nature, turn on the petcock and check for leaks before operating the vehicle.

Fuel Lines

1. Check condition periodically.

2. Check for dry rot, cracking, abrasion or accident damage. Replace defective lines.

3. Check for leaks, even minor ones, around the ends of the lines. Replace leaking lines.

4. When lines are disconnected, check the ends for cracking or deterioration. Connections must be tight.

5. When lines are reconnected, be sure the safety clips are in place.

6. Check for fuel leaks before operating the machine any time lines are removed or replaced.

SPARK ARRESTOR

1. The spark arrestor should be

decarbonized every 30 operating days. Excessive carbon buildup will cause sluggish performance and possible engine overheating.

2. Park the machine in an open area free of flammable material.

3. On 1985 and later ATC 125 machines, remove the bolt and sealing washer.

4. On other models, remove the spark arrestor bolts and pull it out of the exhaust pipe.

5. On models with a removable spark arrestor, use a wire brush to remove build-up carbon from the unit.

6. On all models, start the engine and, after it reaches operating temperature, rev it several times to blow out the carbon.

CAUTION: Hot carbon particles may represent a fire hazard if this procedure is carried out in an unsuitable location.

7. Shut off the engine.

8. After the exhaust system has cooled, replace the arrestor on those machines with a removable unit.

9. On 1985 and later 125s, install the bolt and sealing washer and tighten the bolt to 22-29 ft. lbs.

PERIODIC MAINTENANCE INTERVALS ①

Before every ride

Check engine oil level

Check tire pressure

Check throttle operation

Check brake adjustment

Check operation of lights, if equipped

Every 30 operating days

Change engine oil

Clean oil filters

Check air filter element

Check battery level, if equipped

Clean fuel system

Lubricate and adjust drive chain

Adjust clutch

Decarbonize spark arrestor

Check tightness of critical fasteners

Inspect tires for condition

Adjust cables

Carry out general chassis lubrication

Every year

Check condition of fuel lines

Check brake shoes

Check wheel and steering head bearings

① Based on normal usage after initial break-in is completed

RECOMMENDED LUBRICANTS

Engine

Above 32°F

SAE 20W-40, SAE 20W-50, service rated "SE" or "SF"

Above 18°F

SAE 10W-40, service rated "SE" or "SF"

18-85°F

SAE 10W-30, service rated "SE" or "SF"

Below 45°F

SAE 5W, service rated "SE" or "SF"

Drive chain (O-ring)

SAE 80 or 90 oil

Commercial chain lubes compatible with rubber

Drive chain (standard)

Commercial chain lubes

SAE 80 or 90 oil

RECOMMENDED LUBRICANTS

Air filter	SAE 80 or 90 gear oil
Wheel and steering head Bearings	Waterproof, medium-weight bearing grease
General lubrication	Waterproof, medium-weight chassis grease
Cables	Light motor oil Commercial cables lubricants Molybdenum disulphide-based lubricant

TUNE-UP

NOTE: Common tune-up procedures are explained in detail in the "General Information" section of this manual.

CAUTION: All tune-up procedures done with the engine running must be carried out with the machine on level ground in a well-ventilated area. The parking brake should be applied.

Keep children and other innocents away from hot, running engines. Never leave the vehicle running and unattended.

COMPRESSION TEST

1. A compression check should be made before each tune-up since this will provide a general idea of engine condition.

2. It is necessary to have a gauge with the proper adapter if a screw-in type gauge is used. Plug holes are 10mm and 70cc engines, 12mm on the others. The less expensive "hold-in" type gauge can also be used. Oil the rubber tip to ensure a good seal.

3. The engine must be at operating temperature.

4. Be sure the choke is fully on.

5. Turn the ignition switch "OFF."

6. Fit the gauge. Push the throttle lever wide open and turn the engine over with the recoil starter.

7. The highest gauge reading is the compression.

8. Standard compression is about 175 ± 22 psi.

9. Low compression may be caused by valves which are too tightly adjusted, burned or otherwise damaged, worn piston rings, piston and/or cylinder or other worn engine components.

10. If the compression reading is too low, squirt some motor oil into the cylinder and repeat the test. If the gauge reading is higher, suspect worn rings, piston or cylinder as the cause. If the reading does not increase, suspect problems in the valve train.

11. If the test shows that compression is too high, the problem is likely due to carbon deposits on the piston crown and cylinder. Remove the cylinder head and decarbonize the top end.

CAM CHAIN TENSION

1985 and Later

Cam chain tension is maintained automatically by a spring-loaded plunger operated

by oil pressure. No routine adjustment is required.

1984 and Earlier

1. Cam chain adjustment is made with the engine idling. The adjustments can be made in two ways: either with the adjusting screw or with the tensioner bolt.

The adjusting screw locks the spring-loaded tensioner rod in place, and loosening it will allow tension to be automatically taken up.

The tensioner bolt allows the tensioner rod to be moved, compressing the tensioner itself.

The adjusting screw is located at the bottom of the left crankcase cover. The tensioner bolt is just below the adjusting screw, beneath a cover bolt.

2. With the engine idling, loosen the adjusting screw locknut and back the screw off (counterclockwise) about 1 1/2 turns. Tighten the adjusting screw. If chain operation is now quiet, tighten the adjusting screw locknut, since the adjustment is now complete. If chain operation is still noisy, proceed as follows:

3. Remove the tensioner cover bolt. Loosen the adjusting screw locknut and back off the adjusting screw about 1 1/2 turns.

4. Turn the tensioner bolt in or out slowly until proper chain operation is obtained. If the chain chatters, it is too loose and the tensioner bolt should be turned clockwise; if the chain whines, it is too tight, and the tensioner bolt should be turned counterclockwise.

5. When chain operation is quiet, replace the cover bolt, tighten the adjusting screw and the adjusting screw locknut. Adjustment is now complete. Tighten the cover bolt to 14-25 ft. lbs.

VALVE ADJUSTMENT

NOTE: Valves must be adjusted when the engine is cold.

1. Remove the spark plug.

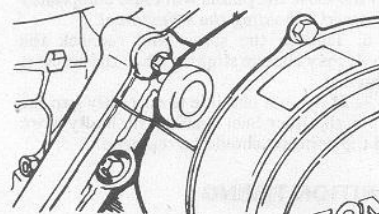

Timing inspection hole

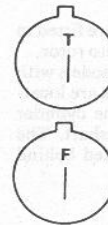

TOP DEAD CENTER

IGNITION TIMING MARK

Rotor timing marks

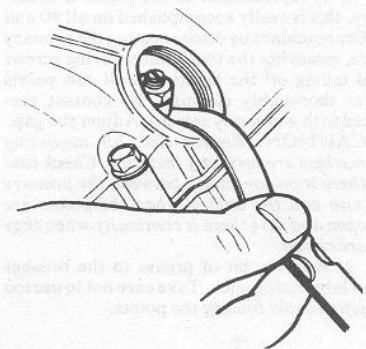

Checking valve clearance

2. Remove the intake and exhaust valve adjuster covers.

3. Remove the timing inspection hole cap on the left crankcase cover, if one is fitted. If not, remove the recoil starter assembly.

4. Turn the engine over slowly while watching the intake rocker arm and the magneto rotor.

NOTE: The rotor must be turned counterclockwise.

5. When the intake rocker arm opens the valve and then begins to close it, check the magneto rotor timing marks relative to the timing index mark. When the "T" mark on the rotor aligns with the index mark, stop. The piston should now be at TDC on the compression stroke.

6. Check for rocker arm clearance at the valves. Each rocker arm should have a slight amount of free-play. If they do not, the piston is probably at TDC on the exhaust stroke. Turn the rotor 360°, align the "T" mark and check again.

7. Valve clearances are as follows:

ATC 70, 90: 0.05mm/0.002 in.

ATC 110, 125 0.07mm/0.003 in.

These figures are for both intake and exhaust valves. A feeler gauge blade of the proper

Honda ATC 70-125

thickness should be a light slip fit between the valve and the adjuster.

8. If adjustment is necessary, loosen the adjuster locknut and turn the adjuster so that the feeler gauge blade is a slip fit. Hold the adjuster in place and tighten the locknut (torque: 11-13 ft. lbs.)

9. After the locknut is tightened, recheck clearance.

10. Install and tighten the adjuster covers to 7-10 ft. lbs.

11. Tighten the spark plug to 9-14 ft. lbs.

CONTACT BREAKER POINTS

Location

1. On the ATC 70, the points are fitted to the stator plate beneath the magneto rotor.

2. On ATC 90 and ATC 110 models with breaker point ignitions, the points are located in a case on the left side of the cylinder head and are driven off the camshaft. The timing advance mechanism is fitted behind the breaker point plate.

Replacement

ATC 90, 110

1. If replacement of the points is necessary, this is easily accomplished on all 90 and 110cc machines by disconnecting the primary wire, removing the two point securing screws and taking off the points. Install new points after thoroughly cleaning the contact surfaces with a non-oily solvent. Adjust the gap.

CAUTION: Ensure that all insulating washers are correctly installed. Check that there is no continuity between the primary wire and the engine when the points are open and that there is continuity when they are closed.

2. Apply a bit of grease to the breaker cam lubricating wick. Take care not to use too much to avoid fouling the points.

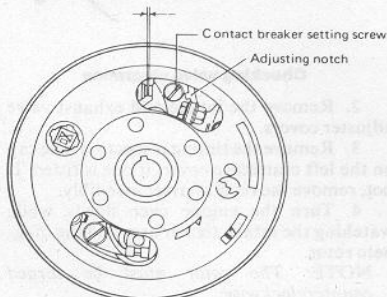

ATC 70 breaker points

ATC 70

1. Remove the recoil starter. Use the special puller to remove the magneto rotor after removing the rotor nut.

NOTE: The puller has a **LEFT-HAND** thread.

2. Disconnect the primary wire; remove the points' securing screw. Install the new point set.

CAUTION: Ensure that all insulating washers are correctly installed. Check that there is no continuity between the primary wire and the engine when the points are open, and that there is continuity when they are closed.

3. Apply a bit of grease to the breaker cam lubricating wick. Take care not to apply too much to avoid fouling the points.

4. Install the rotor. Torque the nut to 22-28 ft. lbs.

5. Adjust the point gap. Adjust the ignition timing.

Gapping

Gapping is necessary to compensate for wear of the contact surfaces due to electrical arcing and for wear of the breaker point fiber heel. As the heel wears the points will open later relative to the rotation of the crankshaft, retarding the timing.

Points should be filed (if necessary) and cleaned before gapping.

NOTE: On ATC 70 machines the ignition timing is adjusted by changing the point gap. Therefore these operations must be carried out at the same time.

ATC 90/110

1. Remove the points cover.

2. Turn the engine over slowly until the points are open to their maximum gap.

3. With the proper feeler gauge, check the gap. The proper specification for all models is 0.012-0.016 in. (0.3-0.4 mm). The feeler gauge should be a slip fit between a correctly gapped point set.

4. If adjustment is necessary, loosen the two screws which secure the points to the base plate, and use a thin screwdriver at the pry slot provided to bring the gap to the proper specification.

NOTE: Loosen the screws just enough to allow the points to be moved. If too loose, the points will snap shut instead of holding the adjustment.

5. Tighten the screws and recheck the gap. It may change slightly when the screws are tightened.

6. If it is not possible to gap the points correctly, the fiber heel is probably worn and the points should be replaced.

ATC 70

1. On this model, adjusting the point gap is the only method of adjusting the ignition timing, so timing should be checked whenever the points are gapped.

2. Remove the recoil starter.

3. Turn the engine over, observing the points through the cutout in the rotor until they are opened to their maximum gap.

4. With a feeler gauge blade, check point gap. Proper gap is 0.012-0.016 in. (0.3-0.4mm).

5. If adjustment is necessary, loosen the point securing screw and use a thin screwdriver at the pry slot provided to bring the gap within the proper specification.

NOTE: Loosen the securing screw just enough to allow the gap to be adjusted. If it is too loose the points will close completely instead of holding the adjustment.

6. Tighten the screw and recheck the gap. It may change slightly when the screw is tightened.

7. If it is not possible to correctly gap the points, the fiber heel is evidently badly worn and the point set should be replaced.

IGNITION TIMING

CAUTION: Running-engine adjustments

must be carried out in a well-ventilated area. Be sure the machine is parked on a level surface and that the parking brake is set.

ATC 70

The timing on these models is accomplished by changing the point gap.

1. Remove the spark plug and the recoil starter.

2. Clean and gap the points to the proper specification as outlined under "Gapping."

3. Hook up the ohmmeter to ground and to the black wire coming from the points.

4. Turn the rotor slowly in the normal direction of rotation (counterclockwise). When the "F" mark on the rotor and the stationary timing mark on the crankcase align, the meter should indicate that the points have just begun to open.

5. If the points open after the "F" mark passes the stationary mark, the timing is too retarded; if they open before the "F" mark aligns, the timing is too advanced.

6. As noted above, ignition timing is corrected by changing the point gap. If the timing was retarded, increase the point gap. If it was advanced, decrease the point gap.

NOTE: It should be possible to set the timing perfectly while maintaining the point gap within the specification given (0.012-0.016 in 0.3-0.4mm). If the timing marks will not align when the point gap is within this specification, the points must be replaced. Wear of the fiber heel is one cause of this conditions.

ATC 90/110 (Breaker Points)

1. Remove the recoil starter and the points cover. Remove the spark plug and intake valve cover.

2. Hook the tester up.

3. Turn the engine over so that the engine is just beginning its compression stroke. (The intake valve will go down and come up). Turn the rotor slowly in the normal direction of rotation (counterclockwise). At the instant in which the "F" mark on the rotor aligns with the mark on the crankcase cover, the points should begin to open as indicated by the reaction of the test light or the meter.

4. If the points open before the marks align, the timing is too advanced. If they open after the "F" mark passes the stationary mark, the timing is too retarded.

5. If the timing is not correct, loosen the two philips screws which secure the breaker base plate to the engine. Loosen them just enough to allow the plate to be rotated.

6. Turn the plate using a thin screwdriver applied to the pry slot provided so that the

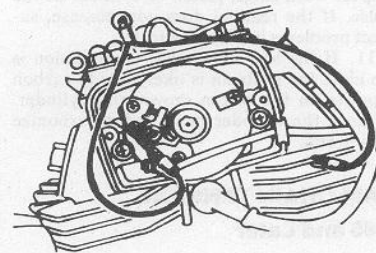

Timing light on breaker point ignition 90 and 110s

Honda ATC 70-125

points open just as the "F" mark lines up with the stationary mark. If the timing was too advanced, turn the plate counterclockwise. If too retarded, rotate the plate clockwise.

7. Tighten the breaker plate screws and recheck the timing. Sometimes this will cause the plate to move slightly and throw the timing off.

ATC 110/125 (CDI)

1. Remove the timing inspection hole cap on the left crankcase cover.
2. Connect a timing light according to the light manufacturer's instructions.
3. Connect an electronic tachometer if idle speed is not known.
4. Observe the rotor timing marks through the inspection hole while the engine is running.
5. At 1700 rpm (± 100 rpm), the "F" mark on the rotor should align with the index mark on the hole.
6. If adjustment is necessary, remove the pulse generator cover on the left side of the cylinder head.
7. Loosen the two base plate screws and turn the plate with a small screwdriver applied to the pry point until the "F" mark aligns with the index mark at 1700 rpm.
8. Tighten the base plate screws. Check that timing is still correct.
9. Shut the engine off.
10. Turn the engine over with the recoil starter until the pulse rotor aligns with the pulse generator.
11. The air gap between the rotor and the pulse generator should be 0.3-0.4mm (0.01-0.02 in.).
12. Adjust by loosening the two small screws which mount the generator to the base plate.

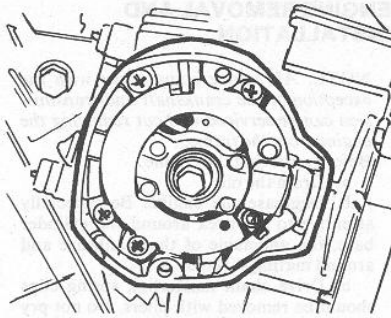

Base plate screws (CDI)

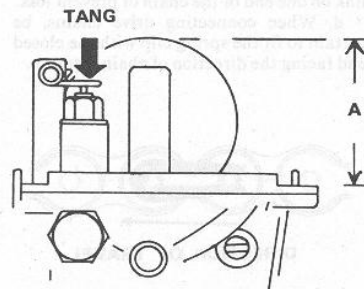

Adjust float level ("A") by bending the tang

13. Install the cover. Install the timing inspection hole cap.

NOTE: Once set properly, the CDI ignition should not require adjustment. Unless the proper equipment (tach and strobe

light) is available, ignition timing should not be attempted.

CARBURETOR

Float Level

1970-77

1. Remove the carburetor.
2. Remove the float bowl.
3. Remove the float bowl gasket.
4. Float level is defined as the measured distance from the float bowl mating surface (gasket removed) to the top of the float when the float tang is just touching the end of the needle.
5. With the float held in this position, measure the distance from the mating surface to the top of the float. It should be 20.0mm (0.78 in.).
6. If the float level is not within 10% of this value, check for foreign matter on the needle tip or seat. Check for wear of the needle tip. Float needle, seat or both must be replaced if worn or corroded.
7. If the components are in acceptable condition, adjust the float level by bending the float tang up or down.

1978 AND LATER

1. Float level is not adjustable. Generally this item need not be checked until considerable mileage has been covered or fuel system problems arise.
2. Remove the carburetor.
3. Remove the float bowl (2 screws).
4. Remove the float bowl gasket.
5. Float level is defined as the measured distance from the float bowl mating surface (gasket removed) to the top of the float when

TUNE-UP SPECIFICATIONS

VALVE CLEARANCE (INTAKE & EXHAUST)	
ATC 70, 90	0.05mm/0.002 in.
ATC 110, 125	0.07mm/0.003 in.
BREAKER POINT GAP	
	0.3-0.4mm/0.012-0.016 in.
SPARK PLUG	
OEM Type	NGK
ATC 70	
1970-81	C7HS
1982-On	CR7HS
ATC 90	D8HS
ATC 110	
1979-81	D8HA, D8HS
1982-On	DR8ES-L
ATC 125	DR8ES-L
Gap	0.6-0.7mm/0.024-0.028 in.
Torque	9-14 ft lbs.
COMPRESSION	
Standard	175 \pm 22 psi
Minimum	128 psi
CARBURETOR	
Idle speed	
ATC 70	1500 \pm 100 rpm
ATC 90	1200 \pm 100 rpm
ATC 110, 125	1700 \pm 100 rpm
Float level	
1970-77	20.0mm/0.78 in.
1978-On	10.7mm/0.42 in.

Honda ATC 70-125

the float tang is just touching the end of the needle.

6. With the float held in this position, measure the distance from the mating surface to the top of the float. It should be 10.7mm (0.42 in.).

7. If the float level is not within 10% of this value, check for foreign matter on the needle tip or seat. Check for wear of and needle tip. Float, needle and seat, or all three must be replaced if the level is not correct.

Idle Speed and Mixture

NOTE: These items must be adjusted when the engine is at operating temperature.

CAUTION: Park the machine on a level surface in a well-ventilated area and set the parking brake.

1. Check that the throttle cable adjustment is correct so that the cable has enough slack to permit the throttle slide to close fully.

2. Screw the pilot in carefully until it is seated, then back it out about 1 1/2 turns.

3. Start the engine and, when it has reached operating temperature, adjust the idle speed as follows:

ATC 70: 1500 ± 100 rpm

ATC 90: 1200 ± 100 rpm

ATC 110, 125: 1700 ± 100 rpm

4. Turn the pilot screw in slowly until the engine stalls, then back it out one full turn.

5. Readjust idle speed, if necessary, to the specification given.

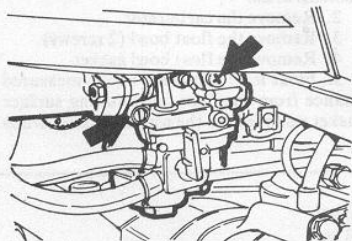

Carburetor pilot (left) and throttle stop (idle) screws

6. Shut the engine off and adjust the throttle cable as outlined in "Maintenance."

NOTE: If proper idling cannot be obtained using this method, it may be that the fuel system is clogged. Check petcock, filter screen, carburetor, gas cap vent. Other possible causes include a dirty or worn spark plug, a plug which is too cold, improperly adjusted valves or air leaks in the intake system.

ENGINE AND TRANSMISSION

NOTE: Engine component removal and installation procedures are given in the following text. Specifications are in the chart at the end of this section. For service procedures and inspection techniques to valves, piston, clutch and other components, refer to "Engine Rebuilding" in the "General Information" section of this manual.

ENGINE REMOVAL AND INSTALLATION

NOTE: All engine components with the exception of the crankshaft and transmission can be serviced without removing the engine from the frame.

Before removing the engine:

- Drain the oil.
- Degrease the engine. Be especially attentive to the area around the cylinder base, the underside of the crankcase and around mating surfaces.
- Drive chain masterlink spring clips should be removed with pliers. Do not pry the clip off with a screwdriver or it will be distorted and will have to be replaced. After disconnecting the chain, install the masterlink on one end of the chain of prevent loss.
- When connecting drive chains, be certain to fit the spring clip with the closed end facing the direction of chain rotation.

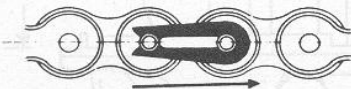

DIRECTION OF TRAVEL

Masterlink spring clip closed end must be installed as shown

ATC 70

- Remove the skid plate.
- Remove the chain case.
- Remove the recoil starter assembly.
- Remove the exhaust pipe nuts at the cylinder head and the muffler mounting bolts. Remove the exhaust system.
- Remove the footpeg mounting bar.
- Remove the carburetor manifold bolts from the cylinder head.
- Remove the Neutral indicator e-clip. Remove the gearshift lever.
- Remove the left crankcase cover.
- Loosen the chain tensioner. Unbolt the engine sprocket.
- Disconnect the spark plug lead. Loosen the spark plug.
- Detach the wiring harness from the frame and disconnect the wires at the connectors.
- Place a jack or other adjustable support beneath the engine.
- Remove the upper and lower engine mounting bolts.
- Remove the engine from the left side of the frame.
- Installation is the reverse of removal. Tighten the engine mounting bolts to 14-18 ft. lbs. Tighten the footpeg bar to 14-18 ft. lbs.

ATC 90/110/125

- Disconnect the spark plug lead and loosen the plug.
- Remove the seat and rear fender assembly.
- On the ATC 125, be sure that the petcock is "OFF" and remove the two screws securing the petcock to the carburetor. Remove the mounting bolt at the rear of the fuel tank and remove the tank.

- Remove the carburetor manifold bolts from the cylinder head.
- Disconnect the battery ground (negative) cable from the battery (ATC 125).
- Disconnect the starter motor cable from the starter motor (ATC 125).
- Remove the left rear wheel.
- Remove the skid plate.
- Remove the chain case axle cover.
- Remove the chain case.
- Remove the exhaust pipe nuts from the cylinder head. Remove the muffler mounting bolts. Remove the exhaust system.
- Remove the footpeg bar.
- Locate the wiring connectors for points or pulse generator and disconnect.
- Locate the magento/alternator wiring connectors on the frame and disconnect.
- Locate the connector of the Neutral indicator wire on the frame and disconnect it.
- Disconnect the breather tube from the crankcase, if fitted.
- Disconnect the drive chain.
- Support the engine by placing a support beneath it.
- Remove the cylinder head bracket.
- Remove the rear engine mounting bolts and take the engine out of the left side of the frame.
- Installation is the reverse of removal. Tighten the cylinder head bracket fasteners to 14-18 ft. lbs. and the rear engine mounting bolts to 22-29 ft. lbs.

TOP END

The following section deals with the removal and installation of the cylinder head, cylinder, piston and related components. Inspection and service procedures are outlined under "Engine Rebuilding" in the "General Information" section of this manual. Specifications are included in the chart at the end of this section.

CAUTION: When removing cylinder head and cylinder, be sure to note the exact locations of all dowel pins, O-rings and collars on head and cylinder base mating surfaces. Proper installation of these components is critical.

ATC 70 REMOVAL

- The engine need not be removed from the frame to remove the cylinder head and cylinder. Remove the exhaust system and the carburetor and manifold from the cylinder.
- Remove the magneto or alternator rotor cover. Remove the spark plug and the valve adjuster caps. Turn the engine over until the intake valve goes down and comes up, and turn it a bit farther so that the "T"

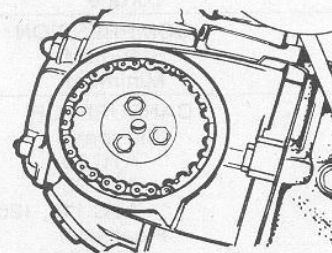

Cam sprocket bolts and sprocket timing mark (arrow) (ATC 70)

Honda ATC 70-125

mark on the rotor aligns with the stationary index mark.

3. Loosen each cylinder head cover nut 1/4 of a turn at a time until they are loose, then remove them. Note that one or two of the nuts are different and must be installed in the location from which they were removed.

On most models, there is one hex nut and three capnuts; an oil sealing washer is fitted beneath the hex nut.

4. Tap the head cover lightly with a plastic mallet to free it if stuck.

5. Remove the bolt from the right side of the cylinder head. This will enable the left side cover to be removed.

6. Remove the two screws on the right side cylinder head cover and remove the cover.

7. Check that the piston is at TDC (the "O" mark on the cam sprocket will be toward the top of the head).

8. Remove the three sprocket mounting bolts, and push in on the camshaft to disengage it from the sprocket. Remove the sprocket after disengaging it from the cam chain.

NOTE: It may be necessary to hold the camshaft in position while removing the sprocket bolts and this can be done if the engine is in the frame by engaging the transmission except for centrifugal clutch models. If the engine is not in the frame, secure the magneto rotor or the counter-shaft sprocket.

9. Remove the cylinder head mounting bolt on the left side of the head. Remove the head, tapping around the mounting surface with a plastic mallet if it is stuck.

10. When the head is removed, remove the two locating pins at the head mating surface and ensure that they are in place when the head is refitted. To remove the rocker arms, thread a suitable bolt into the right side of the rocker arm shafts and pull them out. Keep each rocker arm shaft with its own rocker arm for proper installation. Push the camshaft out of the head.

NOTE: The cylinder head or cylinder mounting bolt can be used to remove the rocker arm shafts.

11. Unscrew and remove the cam chain guide roller pin from the left side of the cylinder and remove the guide roller.

12. Remove the cylinder mounting bolt on the left side and pull off the cylinder. Do not allow the piston to strike the studs as it comes out of the cylinder. Check the location of the two hollow dowel pins on the cylinder studs. Remove these and make sure that they are installed when assembling the top end.

13. To remove the piston, remove the wrist pin circlips with needlenose pliers and push out the wrist pin.

NOTE: Use steady pressure while removing the wrist pin. Support the piston with your other hand. Do not strike or attempt to force out the pin. If it is stuck apply gentle and even heat to the piston crown with a propane torch until the pin is free.

INSPECTION

Refer to the "Engine Rebuilding" section of "General Information" and to the specifications charts at the end of this section for inspection techniques and service limits, respectively.

INSTALLATION

1. If the piston rings were removed or

replaced, be sure that they are installed correctly.

2. Check the profiles of the compression rings. The two rings are not interchangeable. The ring with the plain profile is the top ring and the wedge-shaped ring is the second compression ring.

3. Be sure to install the compression rings with the manufacturer's mark near the end-gap facing upwards.

4. Piston ring end-gaps should be arranged as follows:

a. On models with a one-piece oil ring, arrange end-gaps of the three rings 120° apart around the piston, but not at the very front or rear of the piston or directly above the wrist pin holes.

b. On models with a multi-piece oil ring, end-gaps of the two compression rings and the oil expander should be arranged 120° apart around the piston, but not at the very front or rear of the piston and not directly above the wrist pin holes. The end-gaps of the oil rails should be arranged at about 3/4 in. (20mm) or more - one on either side of the expander end-gap.

5. Install one wrist pin circlip and place the piston on the connecting rod. The triangular mark on the piston crown must be positioned on the cam chain side. Insert the wrist pin and the other circlip. Use new circlips and be sure that they are properly seated. Arrange the circlip end-gaps so that they do not align with the cutouts on the piston. Lubricate the wrist pin, rings, and piston skirt with motor oil.

6. Be sure that the O-ring is in place in the crankcase oil passage and the hollow dowel pins are installed on the cam chain side studs. Fit a new cylinder base gasket. Install the cylinder, compressing the rings with your fingers as the piston enters the bore. Feed the cam chain through the cylinder as it is seated. Install and tighten the cylinder mounting bolt.

7. Install the cam chain guide roller and the roller pin.

8. Install the two hollow pins on the studs: one on the top right stud, the other on the left bottom. Fit the O-rings to the oil passage and to the stud oil passage; fit the head gasket.

9. Install the head, complete with rocker arms and cam, threading the cam chain with its sprocket through, and securing them with a length of wire or a screwdriver.

10. Turn the magneto rotor so that the "T" mark on the rotor is aligned with the index mark on the crankcase. Set the cam sprocket "O" mark at the top of the head. Install and tighten the sprocket bolts to 4-7 ft. lbs. Thread locking compound should be used on these bolts. Lubricate the top end components.

11. The remainder of the procedure is the reverse of disassembly. Note that the cylinder head cover hex nut (on most models) and its copper washer are installed on the lower left stud. Install the head mounting bolt. Tighten the head cover nuts in a cross pattern and in increments of 2-3 ft. lbs. until the proper torque of 6.5-8.7 ft. lbs. is reached. Adjust the cam chain and tappet clearance before starting the engine.

NOTE: The cylinder head cover may be fitted with an arrow mark. If so, install it so that the arrow points towards the exhaust port (down).

ATC 90/110/125

REMOVAL

1. The cylinder head, cylinder and piston can be removed with the engine still in the frame.

2. Disconnect the spark plug lead and remove the plug. Remove the valve adjuster caps.

3. Remove the exhaust pipe nuts at the cylinder head.

4. Remove the three muffler mounting bolts.

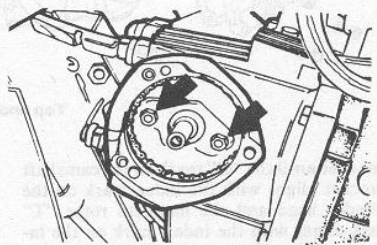

Cam sprocket bolts (ATC 90-125)

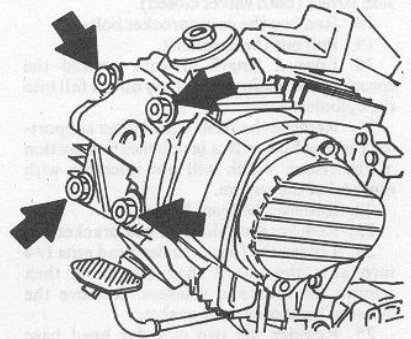

Cylinder head nuts

5. Remove the exhaust system.

6. Remove the manifold bolts on the head and remove the carburetor and manifold.

7. Remove the breaker point or pulse generator cover on the left side of the cylinder head.

8. Disconnect the pulse generator or point wire from the plastic connector on the harness and remove the wire clamp from the cylinder head, if equipped.

9. Remove the base plate screws (2) and remove the base plate.

10. Remove the rotor or advance mechanism bolt.

11. Remove the rotor or advance the mechanism.

12. Remove the pin from the camshaft.

13. Remove the three screws securing the points or generator housing. Remove the housing and gasket from the head.

14. Locate the cam chain tensioner assembly on the left under side of the crankcase.

15. On 1984 and earlier machines, loosen the cam chain locknut and tensioner adjusting screw. On 1985 and later machines, remove the tensioner sealing bolt, washer, tensioner spring and pushrod.

16. Removing the timing inspection hole cap on the left crankcase cover.

17. Use the recoil starter to turn the en-

Honda ATC 70-125

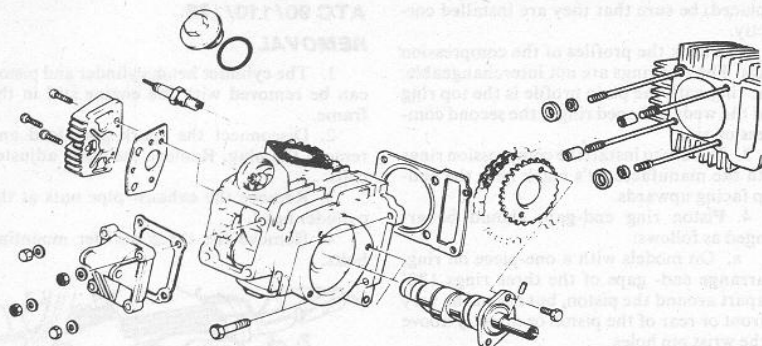

Top end assembly

gine over until the "O" mark on the camshaft sprocket aligns with the index mark on the cylinder head and the magneto rotor "T" mark aligns with the index mark on the inspection hole. The sprocket bolts will be in line with the centerline of the cylinder. This positions the piston at TDC on the compression stroke (both valves closed).

18. Remove the cam sprocket bolts.
19. Pull out the camshaft.
20. Loop a length of wire around the sprocket and chain so that they do not fall into the cylinder.
21. Remove the front wheel after supporting the machine with a jack beneath a portion of the frame which will not interfere with removal of the engine.
22. Remove the front fender.
23. Remove the cylinder head bracket.
24. Loosen the four cylinder head nuts 1/4 turn at a time until they are loose, then remove the nuts and washers. Remove the cylinder head cover and gasket.
25. Remove the two cylinder head base bolts on the left side of the head, if fitted.
26. Remove the head.

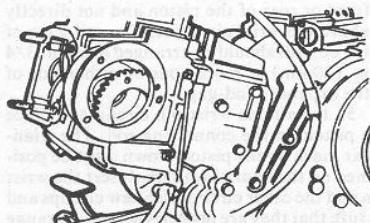

Cylinder head base screws

27. Remove the sprocket from the cam chain.
28. Remove the head gasket.
29. Remove the two cylinder base bolts on the left side of the cylinder, if fitted.
30. Remove the cam chain guide roller bolt from the left side of the cylinder. Remove the roller.
31. Remove the two dowel pins from the cylinder head studs.
32. Remove the O-rings from the cylinder head studs.

33. Carefully pull off the cylinder taking care that the piston does not strike the studs when the cylinder is removed.
34. Remove the cylinder base gasket.
35. Check that the cylinder base dowel pins are in place in the crankcase. If further engine work is contemplated, remove the pins to prevent loss.
36. Stuff a clean, lint-free rag into the crankcase.
37. Remove the piston wrist pin circlips with a needlenose pliers. Push out the wrist pin with a suitable drift. Remove the piston.
38. Remove the four screws and take off the finned cylinder head cover and gasket from the right side of the head.
39. Pull out the rocker arm shafts with a needlenose pliers and remove the rocker arms. Keep each shaft with its own rocker arm and mark them to ensure that they are installed in their original locations during assembly.
40. To remove the valve assemblies, compress the valve springs and remove the keepers.

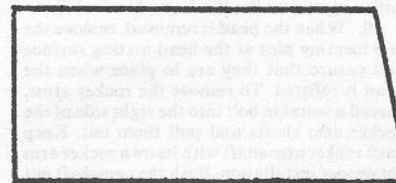
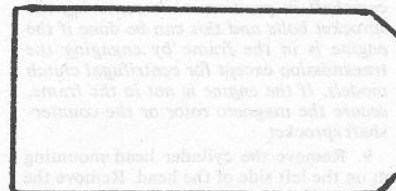

Compression ring profiles

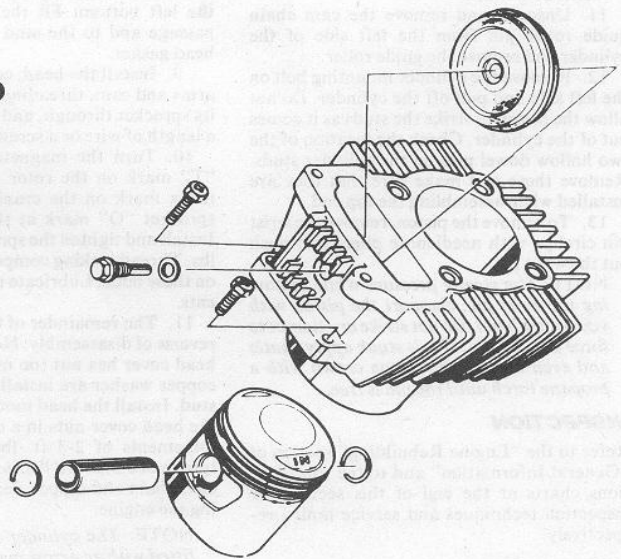
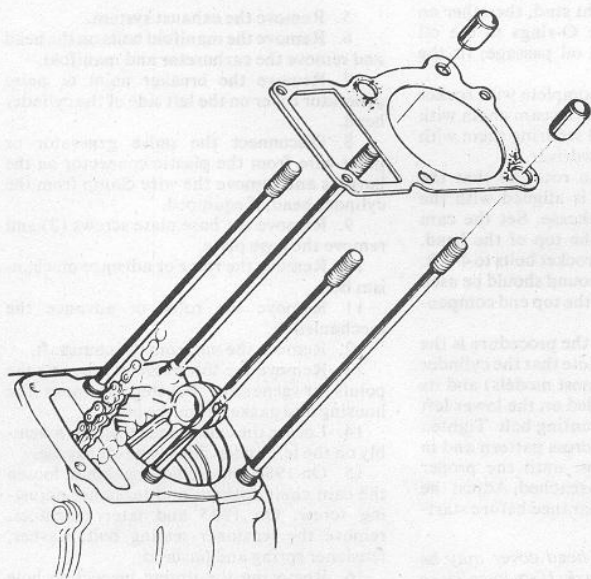

Cylinder and piston assembly

Honda ATC 70-125

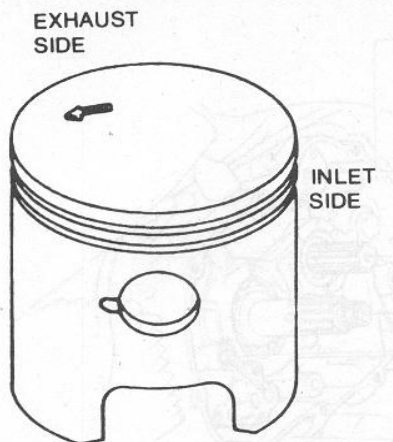

Arrow must point towards the exhaust side (ATC 90-125). On ATC 70s, position piston crown triangle mark on cam chain side

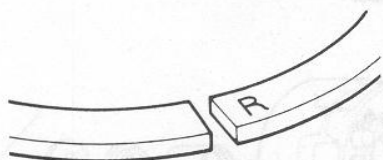

Install rings with manufacturer's mark up

INSPECTION

Refer to the "Engine Rebuilding" section of "General Information" and to the specifications chart in this section for inspection techniques and service limits.

INSTALLATION

1. If the piston rings were removed or replaced, be sure that they are installed correctly.
2. The two compression rings are not interchangeable. The top ring has a plain profile, while the second is wedge-shaped.
3. Be certain to install the compression rings with the manufacturer's mark near the end-gap facing upwards.
4. The piston ring end-gaps should be arranged as follows:
 - a. End-gaps of the two compression rings and the oil expander ring should be arranged 120° apart around the piston but not at the very front or rear of the piston and not directly above the wrist pin holes.
 - b. The end-gaps of the oil rails should be arranged at about 3/4 in. (20mm) or more on either side of the oil expander ring end-gap.
5. Thoroughly clean the cylinder mating surface.
6. Check that the two dowel pins are in place on the right side cylinder head studs.
7. Use a new cylinder base gasket.
8. Install the piston on the connecting rod so that the "IN" mark on the piston crown is on the intake side.
9. Use new wrist pin circlips. Be sure the circlips are properly seated. The circlip end-gaps should not align with the cut-outs at the wrist pin hole.

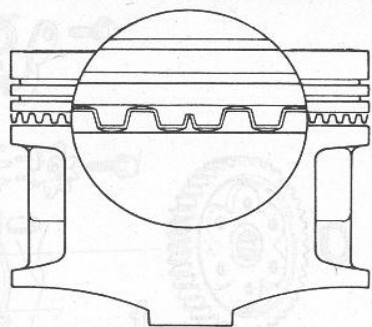

Ends of the oil ring expander must abut, not overlap

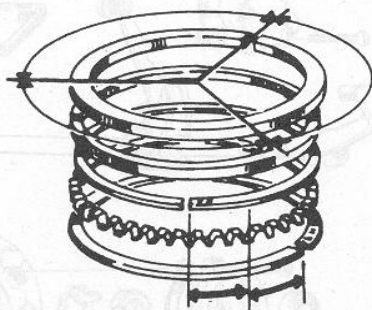

Position ring end gaps around the piston as shown

10. Lubricate the piston and rings. Check that the ring end-gaps are properly aligned.
11. Compress the rings and slide the cylinder over the piston. Pull the cam chain through the cylinder.
12. When the cylinder is seated, install and tighten the cylinder base bolts, if fitted.
13. Fit the cam chain guide roller. Tighten the roller bolt to 7-10 ft. lbs.
14. Use new valve seals when assembling the head.
15. Valve springs are progressively wound. They are installed with the close coils against the head.
16. Lubricate valve stems before inserting them into the guides.
17. After the valve and spring assemblies have been installed, rap the end of each valve smartly with a plastic mallet to ensure that the keepers are properly seated.
18. Lubricate each rocker arm shaft and slip it into place. Use a new gasket beneath the finned cover.
19. Be sure the dowel pins, O-rings and

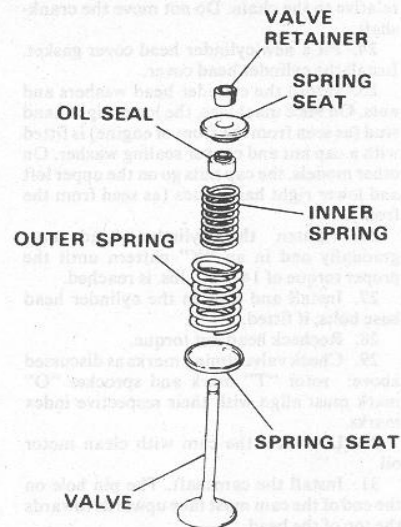

Valve assembly

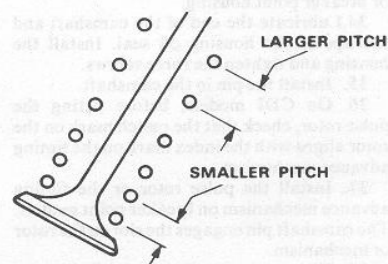

Progressively wound valve springs are fitted with the close coils against the head

collars are in place on the correct cylinder head studs.

20. Use a new cylinder head gasket.
21. Pull the cam chain taut and ensure that it is not jammed or kinked anywhere.



TOP DEAD CENTER



IGNITION TIMING MARK

Rotor timing marks

22. Thread the cam sprocket on the chain. Turn the engine so that the magneto rotor "T" mark is aligned with the inspection index mark. The piston will be at TDC. At this point, fit the chain over the cam sprocket so that the "O" mark on the sprocket is at the top of the cylinder head and the sprocket bolt holes are aligned with the centerline of the cylinder.

23. Install the cylinder head. Pull the cam sprocket through. With the rotor "T" mark aligned with the index mark, the "O" mark on the sprocket must align with the index mark on the head. If it does not, move the sprocket

Honda ATC 70-125

relative to the chain. Do not move the crankshaft.

24. Fit a new cylinder head cover gasket. Install the cylinder head cover.

25. Install the cylinder head washers and nuts. On 90cc machines, the lower right hand stud (as seen from the front of engine) is fitted with a cap nut and copper sealing washer. On other models, the cap nuts go on the upper left and lower right hand studs (as seen from the front).

26. Tighten the cylinder head nuts gradually and in an "X" pattern until the proper torque of 14-16 ft. lbs. is reached.

27. Install and tighten the cylinder head base bolts, if fitted.

28. Recheck head nut torque.

29. Check valve timing marks as discussed above: rotor "T" mark and sprocket "O" mark must align with their respective index marks.

30. Lubricate the cam with clean motor oil.

31. Install the camshaft. The pin hole on the end of the cam must face upwards towards the top of the head.

32. Install the sprocket bolts. Using a non-permanent thread-locking compound is recommended. Torque the bolts to 6-9 ft. lbs.

33. Fit a new gasket behind the generator or breaker point housing.

34. Lubricate the end of the camshaft and the lips of the housing oil seal. Install the housing and tighten the three screws.

35. Install the pin in the camshaft.

36. On CDI models, before fitting the pulse rotor, check that the punch mark on the rotor aligns with the index mark on the timing advance mechanism.

37. Install the pulse rotor or the timing advance mechanism on breaker point models. The camshaft pin engages the slot on the rotor or mechanism.

38. Tighten the cam bolt to 6-9 ft. lbs.

39. Install the base plate assembly.

40. On CDI models, turn the crankshaft so that the "F" mark on the magneto rotor is aligned with the inspection hole index mark.

41. On CDI models, turn the pulse generator base plate so that the pulse generator tooth aligns with the pulse rotor index mark. Tighten the base plate screws.

42. 1985 and later:

a. Install the cam chain tensioner pushrod, spring, washer and sealing bolt, if removed.

b. Remove the oil hole bolt from the crankcase above the tensioner bolt.

c. Fill the pushrod with motor oil until it comes out of the bolt hole. Install the oil hole bolt.

43. Adjust cam chain tension (see "Maintenance.")

44. Turn the engine over slowly with the recoil starter. If resistance is felt, stop immediately and determine the cause. Check that the timing marks all align after one complete engine revolution.

45. Adjust valve clearance as outlined in "Maintenance."

46. The remainder of the procedure is the reverse of removal. Tighten the cylinder head bracket hardware to 14-18 ft. lbs., where applicable.

RIGHT CRANKCASE COVER COMPONENTS

The right crankcase cover contains the

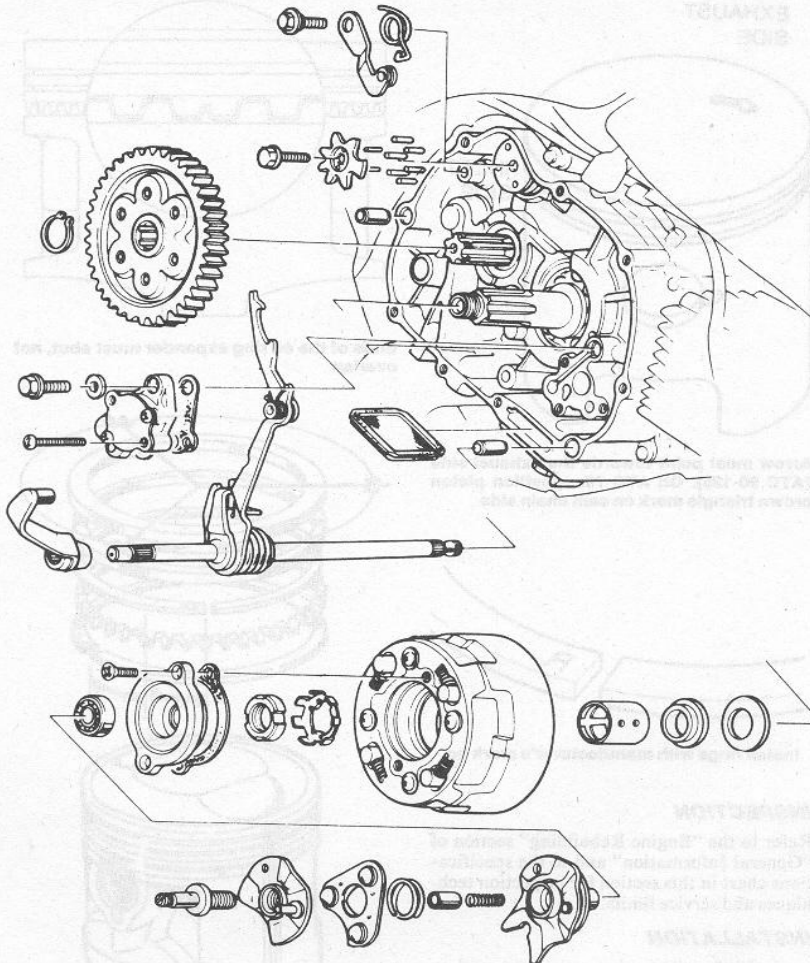

Right crankcase cover components

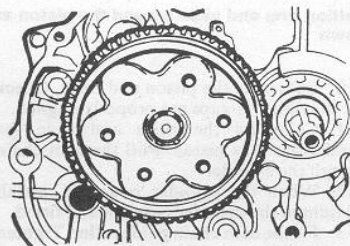

Primary driven gear circlip

clutch, oil pump, primary driven gear and external shift mechanism. All of these components can be serviced without removing the engine from the frame.

Removal

ATC 70

1. Drain the engine oil.
2. Remove the exhaust pipe.
3. Remove the footpegs.

4. Remove the carburetor manifold bolts from the cylinder head.

5. Support the engine with a jack or suitable substitute to take the weight off the upper engine mounting bolt. Remove the bolt.

6. Loosen the lower engine mounting bolt.

7. Lower the engine until the right crankcase cover is clear of the frame.

8. Place a drip pan beneath the crankcase cover to catch any residual oil which may come out.

9. Remove the cover bolts. Remove the cover. If it is stuck, tap it with a plastic mallet to break it free.

10. Note the locations of the dowel pins on the cover mating surface. Be sure that they are not misplaced.

11. For safety while working, raise the engine and slip the upper engine mounting bolt into place.

12. Remove the components as outlined under "All Models," below.

ATC 90/110/125

1. Remove the seat.
2. Drain the crankcase oil.

3. Place a drip pan beneath the right crankcase cover.
4. Remove the starter motor bracket, if fitted.
5. Remove the crankcase cover screws.
6. Remove the crankcase cover. If it is stuck, tap it with a plastic mallet to break it free.
7. Note the locations of the two locating dowel pins on the mating surface.
8. Remove the components as outlined under "All Models," below.

ALL MODELS

1. Remove the ball retainer and clutch cam plate side spring.
2. Remove the oil passage pipe and spring.
3. Remove the clutch cam plate.
4. Remove the clutch outer cover screws.
5. Remove the release lever.
6. Bend up the locking tap on the clutch nut washer.
7. Remove the clutch nut.
8. Remove the clutch assembly.
9. Remove the clutch center guide.
10. Remove the primary driven gear snap ring.
11. Remove the primary driven gear.
12. To remove the oil pump, remove the hex head bolt and the three pump mounting screws.
13. Remove the gearshift pedal pinch bolt and carefully pull the pedal off the shaft.
14. Clean the exposed splines of the shift shaft to remove any burrs or sharp edges so they won't damage the oil seal.
15. Remove the shift drum stopper bolt and the stopper.
16. Disengage the fingers of the shift arm from the shift drum pins and pull the external shift mechanism out of the case.
17. Remove the shift drum stopper plate, if required.

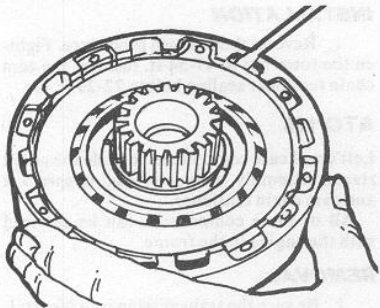

Removing the clutch snap-ring

Inspection

CLUTCH

1. Compress the clutch assembly and remove the large snap-ring on the inner side. Carefully release pressure and separate the components.
2. Remove the snap-ring to separate the primary drive gear from the clutch hub.
3. If further disassembly is required, remove the clutch damper springs from the housing. Remove the four phillips screws from the outer side of the housing and separate the drive plate, clutch springs and housing.

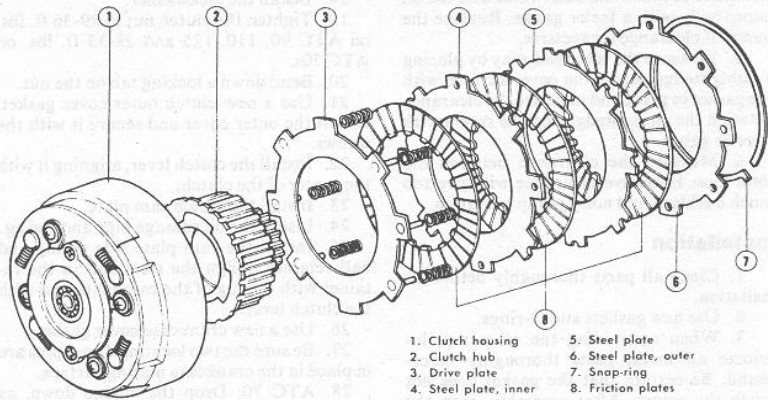

1. Clutch housing
2. Clutch hub
3. Drive plate
4. Steel plate, inner
5. Steel plate
6. Steel plate, outer
7. Snap-ring
8. Friction plates

Clutch assembly

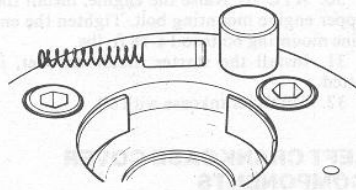

Clutch roller, plunger and spring assembly

4. To complete disassembly, remove the clutch weight stopper ring from the drive plate.
5. Measure clutch spring free length.
6. Check friction plates for worn or damaged friction material. Measure thickness and compare to the given specification.
7. Check steel plates for warpage.
8. Check plate tabs for chipping, wear or other damage.
9. Measure primary gear ID and center guide OD and compare to the specifications.
10. Check gear teeth for pitting, chipping or other damage. Check gears for heat discoloration.

SHIFT MECHANISM

1. Check the splines of the gearshift shaft. If the splines are broken or torn to the extent that it is difficult to properly secure the shift lever, replace the shaft.
2. Check the condition of the shift arm. Be sure that it is not bent. Check that the shift fingers are not bent or worn.

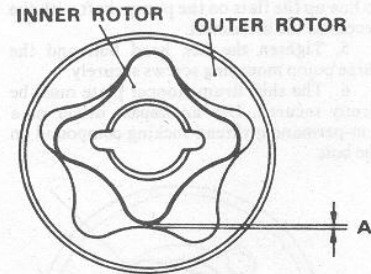

Rotor tip clearance ("A")

3. Check the condition of the springs in the shift linkage, especially the shift lever return spring. If any spring is broken, has lost its tension, or fails to hold its component properly, replace it.
4. Check the condition of the shift drum stopper roller and replace it if worn. The stopper spring should hold the stopper firmly against the stopper plate.
5. Check the stopper plate and pins for wear. Replace if damage.

OIL PUMP

1. Remove the cover screws and remove the cover.
2. Remove the inner and outer rotors.
3. Check all parts for scoring, discoloration or other obvious signs of wear.
4. Install the rotors and measure the

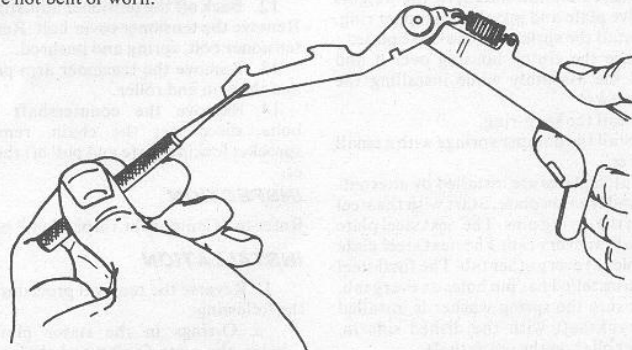

Check shift fingers for damage

Honda ATC 70-125

clearance between the outer rotor and the oil pump body with a feeler gauge. Replace the pump if clearance is excessive.

5. Measure the rotor end-play by placing a straightedge across the cover surface with the gasket in place and measure the clearance between the straightedge and the rotors with a feeler gauge.

6. Measure the clearance between the rotor tips. Excessive clearance will give too much backlash and noisy pump operation.

Installation

1. Clean all parts thoroughly before installation.

2. Use new gaskets and O-rings.

3. When assembling the oil pump, lubricate all metal parts thoroughly beforehand. Be certain that the gasket does not touch the rotors. After assembly, turn the pump by hand. There should be little resistance.

4. Install the pump on the engine. Be sure to line up the flats on the pump shaft with the recess on the driveshaft.

5. Tighten the hex head bolt and the three pump mounting screws securely.

6. The shift drum stopper plate must be firmly secured. Use an impact driver or a non-permanent thread-locking compound on the bolt.

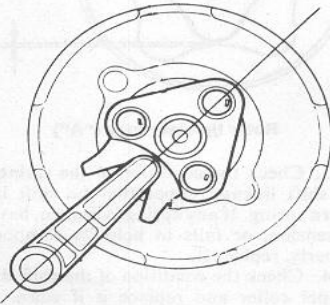

Install the clutch lever as shown

7. Install the external shift mechanism shaft assembly, locating the ends of the return spring on either side of the stopper pin and engaging the fingers of the shift arm with the shift drum pins. Be careful when installing the shaft as there is an oil seal on the left side of the engine.

8. Install the shift drum stopper.

9. Install the primary driven gear.

10. To assemble the clutch, fit the weights on the drive plate and install the stopper ring.

11. Install the springs on the drive plate.

12. Place the clutch housing over it and compress the assembly while installing the phillips screws.

13. Install the snap-ring.

14. Install the damper springs with a small screwdriver.

15. Clutch plates are installed by alternating steel and friction plate. Start with the steel plate with the spring pins. The next steel plate has cut-outs at every tab. The next steel plate has pin holes at every other tab. The final steel plate to be installed has pin holes on every tab.

16. Be sure the spring washer is installed on the crankshaft with the dished side in. Install the collar on the crankshaft.

17. Install the clutch assembly.

18. Install the lockwasher.

19. Tighten the clutch nut to 29-36 ft. lbs. on ATC 90, 110, 125 and 28-33 ft. lbs. on ATC 70s.

20. Bend down a locking tab on the nut.

21. Use a new clutch outer cover gasket. Install the outer cover and secure it with the screws.

22. Install the clutch lever, aligning it with the center of the clutch.

23. Install the clutch cam plate.

24. Install the oil passage pipe and spring.

25. Install the cam plate side spring and ball retainer. Align the steel ball in the retainer with the lug of the cam plate and with the clutch lever.

26. Use a new crankcase cover gasket.

27. Be sure the two locating dowel pins are in place in the crankcase mating surface.

28. ATC 70: Drop the engine down, as before, so that the cover can be installed.

29. Install the cover and tighten the screws evenly.

30. ATC 70: Raise the engine, install the upper engine mounting bolt. Tighten the engine mounting bolts to 14-18 ft. lbs.

31. Install the starter motor bracket, if fitted.

32. Fill the crankcase with oil.

LEFT CRANKCASE COVER COMPONENTS

ATC 70

Left crankcase cover components include the recoil starter, magneto, engine sprocket and cam chain tensioner assembly.

All of these components can be serviced with the engine in the frame.

REMOVAL

1. Drain the oil.

2. Remove the recoil starter assembly.

3. Remove the exhaust pipe.

4. Remove the footpeg bar.

5. Remove the chain case.

6. Remove the E-clip and remove the Neutral indicator.

7. Remove the left crankcase cover.

8. Remove the starter pulley from the rotor.

9. Remove the rotor nut. Using the special puller, remove the rotor.

10. Remove the rotor nut. Using the special puller, remove the rotor.

11. Remove the two screws which secure the coil stator plate. Tap the plate lightly to rotate it, then remove it.

12. Back off the tensioner adjusting screw. Remove the tensioner cover bolt. Remove the tensioner bolt, spring and pushrod.

13. Remove the tensioner arm pivot bolt, and the arm and roller.

14. Remove the countershaft sprocket bolts, disconnect the chain, remove the sprocket locking plate and pull off the sprocket.

INSPECTION

Refer to "Component Inspection," below.

INSTALLATION

1. Reverse the removal procedures. Note the following:

a. O-rings in the stator plate screw holes, the plate O-ring and the crankshaft oil seal must be replaced.

b. Tighten the rotor nut to 24-27 ft. lbs. Tighten the starter driven pulley bolts to 6-9 ft. lbs. Tighten the cam chain tensioner sealing bolt to 15-18 ft. lbs. Tighten the engine sprocket plate bolts to 10 ft. lbs.

ATC 90/110

Left crankcase cover components include the recoil starter assembly, magneto, engine sprocket and cam chain tensioner assembly.

All of these components can be serviced with the engine in the frame.

REMOVAL

1. Be sure the transmission is in Neutral.

2. Remove the gearshift lever pinch bolt and carefully pull the lever off its shaft.

3. Remove the three bolts that secure the recoil starter assembly. Remove the recoil starter.

4. Remove the gasket.

5. Remove the starter driven pulley bolts and pulley.

6. Remove the rotor nut and washer.

7. Using the special puller, remove the rotor.

8. Disconnect the magneto wires at the connectors.

9. Remove the stator bolts and take off the stator.

10. If disassembly past this point is required, drain the engine oil.

11. Remove the sub-transmission cover.

12. Remove the sub-transmission gears.

13. Remove the left crankcase cover screws and the cover.

14. Remove the gasket and dowel pins.

15. Remove the cam chain tensioner sealing bolt, spring and pushrod.

16. Disconnect the drive chain to remove the engine sprocket.

INSPECTION

Refer to "Component Inspection", below.

INSTALLATION

1. Reverse the removal procedure. Tighten the rotor nut to 47-54 ft. lbs. and the cam chain tensioner sealing bolt to 22-29 ft. lbs.

ATC 125

Left crankcase components include the recoil starter assembly, magneto, engine sprocket and cam chain tensioner.

All of these components can be serviced with the engine in the frame.

REMOVAL

1. Be sure the transmission is in Neutral.

2. Remove the gearshift lever pinch bolt and carefully pull the lever off its shaft.

3. Remove the recoil starter assembly (3 screws).

4. Remove the gasket.

5. If further disassembly is required.

6. Remove the pulley bolt.

7. Remove the pulley.

8. Remove the air cleaner hose.

9. Disconnect the alternator wires.

10. Remove the Neutral indicator E-clip and washer.

11. Remove the sub-transmission cover bolts.

12. Remove the dowel pins.

13. Remove the gasket.

14. Remove the sub-transmission components.

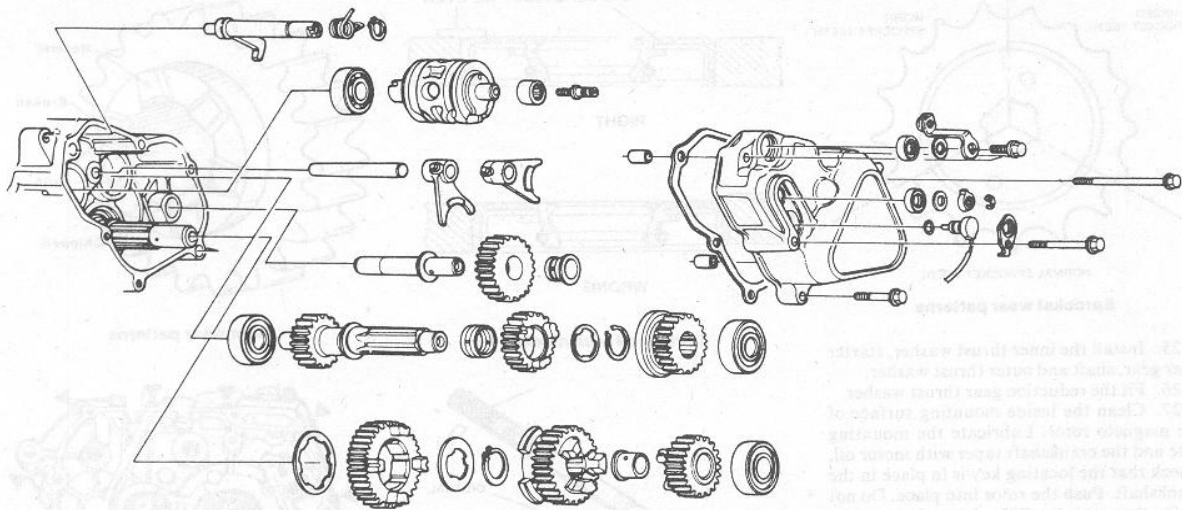

Sub-transmission components

15. Remove the left crankcase cover bolts.
16. Remove the flywheel with a suitable puller.
17. Remove the thrust washers, starter idler gear and shaft.
18. Remove the starter reduction gear washer.
19. Remove the bolt securing the starter driven gear set plate. Remove the plate.
20. Remove the starter driven gear and the needle bearing.
21. Remove the seven bolts securing the left crankcase cover spacer and remove the spacer.
22. Remove the two dowel pins from the crankcase mating surface.
23. Remove the two screws securing the cam chain tensioner guide sprocket set plate. Remove the sprocket.
24. Unscrew and remove the cam chain tensioner oil hole bolt and washer.
25. Remove the tensioner sealing bolt and washer and the spring and pushrod.
26. Disconnect the drive chain at the masterlink.
27. Remove the engine sprocket and bushings.

INSPECTION

Refer to "Component Inspection", below.

INSTALLATION

1. Use new gaskets and O-rings.
2. Clean all metal parts in a safe solvent and dry thoroughly.
3. Lubricate all metal parts with motor oil before assembly.
4. Grease the lips of all seals before installation.
5. Wrap the starter rope around the pulley in a clockwise direction when viewed from the ratchet side of the pulley.
6. Install the recoil spring in the housing, hooking the end of the spring in the place provided.
7. Grease the spring thoroughly.
8. Install the pulley shaft collar.

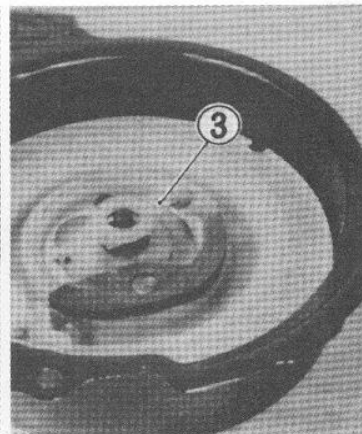
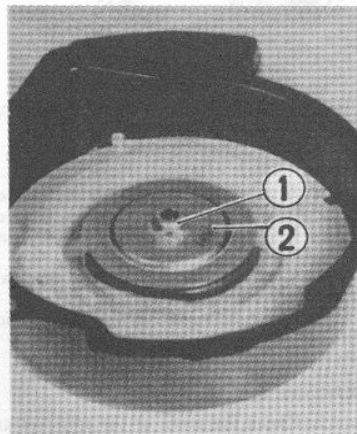

Recoil starter nut (1), ratchet cover (2) and guide (3)

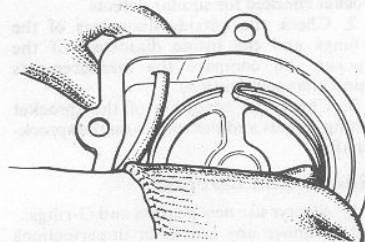

Engage the end of the coil spring into the boss provided

9. Grease the pulley shaft and install the pulley, hooking the end of the spring on the starter housing hook.
10. Turn the pulley two full turns clockwise.
11. Pull the starter rope through the hole and install the handle. Knot the end of the rope. Fit the handle cover.

12. Grease the ratchet and install it on the pulley.
13. Install the spring, spring seat and ratchet guide.
14. Install the cover. Install the cover nut.
15. Check recoil starter operation.
16. Lubricate the engine sprocket bushings and install bushings and sprocket.
17. Connect the drive chain.
18. Install the cam chain guide sprocket and set plate.
19. Fit a new crankcase cover spacer gasket.
20. Check that the two locating dowel pins are in place on the crankcase mating surface.
21. Install the spacer and secure it with the seven bolts. Bolts should be tightened gradually and evenly.
22. Install the starter driven gear spacer on the crankshaft.
23. Install the starter driven gear and needle bearing.
24. Install the driven gear set plate and bolt.