

**Official**

# HONDA

## SHOP MANUAL

**ATC 185**  
**ATC 185S**  
**ATC 200**

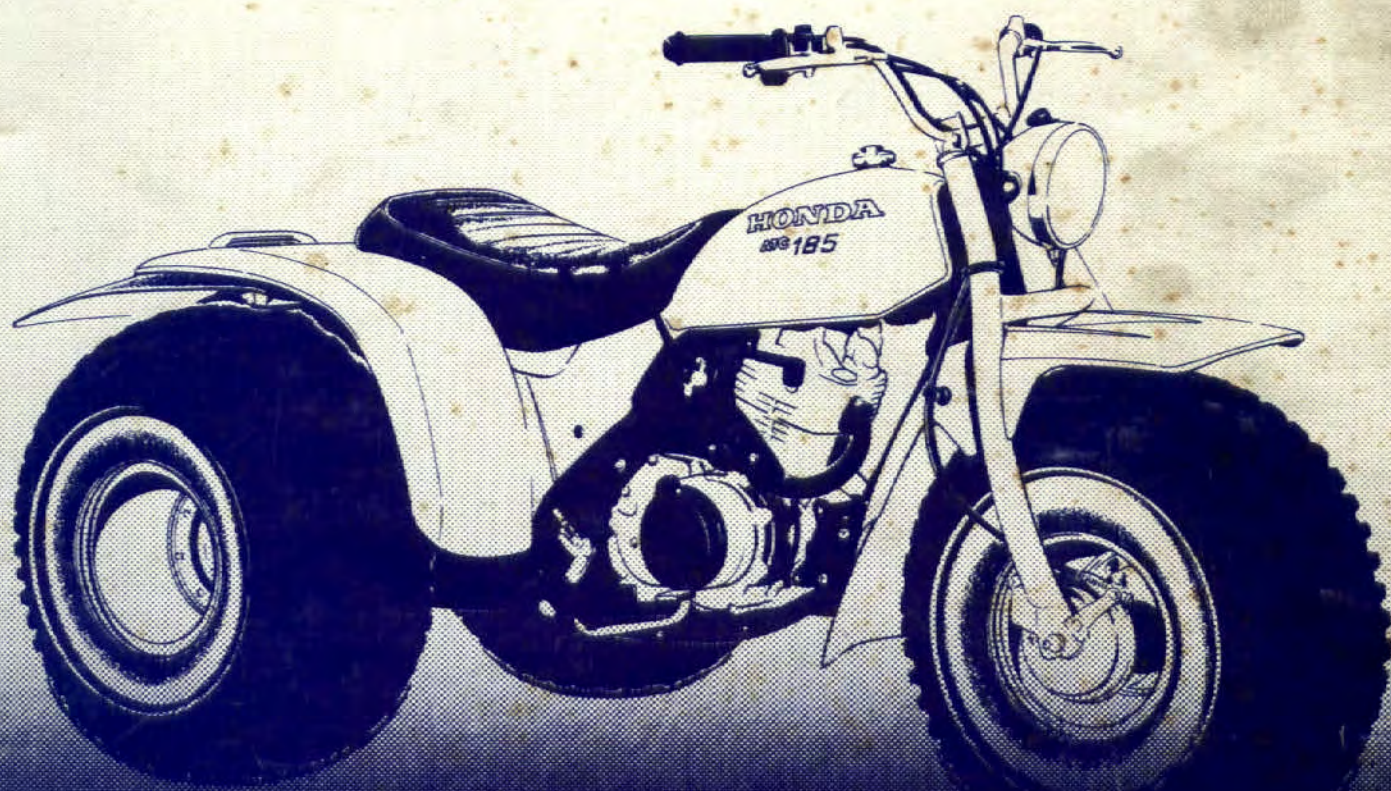

**ATC 185 '80**  
**ATC 185S/200 '81-83**

## IMPORTANT SAFETY NOTICE

 **WARNING** Indicates a strong possibility of severe personal injury or loss of life if instructions are not followed.

**CAUTION:** Indicates a possibility of personal injury or equipment damage if instructions are not followed.

**NOTE:** Gives helpful information.

Detailed descriptions of standard workshop procedures, safety principles and service operations are not included. It is important to note that this manual contains *some* warnings and cautions against some specific service methods which could cause **PERSONAL INJURY** to service personnel or could damage a vehicle or render it unsafe. Please understand that those warnings could not cover all conceivable ways in which service, whether or not recommended by Honda might be done or of the possibly hazardous consequences of each conceivable way, nor could Honda investigate all such ways. Anyone using service procedures or tools, whether or not recommended by Honda *must satisfy himself thoroughly* that neither personal safety nor vehicle safety will be jeopardized by the service method or tools selected.



## HOW TO USE THIS MANUAL

Sections 1 through 3 apply to the whole motorcycle, while sections 4 through 15 describe parts of the motorcycle, grouped according to location.

Find the section you want on this page, then turn to the table of contents on page 1 of that section.

Most sections start with an assembly or system illustration and all the required specifications, torque values, general instructions, tools and troubleshooting for the section. The subsequent pages give detailed procedures.

If you don't know the source of the trouble, see section 18, TROUBLESHOOTING.

Read Technical Feature section 17 if you are unfamiliar with the ATC185/200 clutch operation.

Refer to the addendums at the back of the manual for 1981 and subsequent model year information.

## CONTENTS

	GENERAL INFORMATION	1
	LUBRICATION	2
	INSPECTION/ADJUSTMENT	3
ENGINE	FUEL SYSTEM	4
	ENGINE REMOVAL/INSTALLATION	5
	CYLINDER HEAD/VALVES	6
	CYLINDER/PISTON	7
	CLUTCH/OIL PUMP	8
	STARTER/A.C. GENERATOR	9
	TRANSMISSION/CRANKSHAFT	10
CHASSIS	FRONT WHEEL/BRAKE/STEERING	11
	REAR WHEEL/BRAKE/DRIVE MECHANISM	12
	REAR FENDER/EXHAUST PIPE	13
ELECTRICAL	IGNITION SYSTEM	14
	LIGHTS/SWITCHES	15
	WIRING DIAGRAM	16
	TECHNICAL FEATURE	17
	TROUBLESHOOTING	18
	'81 ATC185S • 200 ADDENDUM	19
	'82 ATC185S • 200 ADDENDUM	20
	'83 ATC185S • 200 ADDENDUM	21



## MODEL IDENTIFICATION



The frame serial number is stamped on the steering head left side.

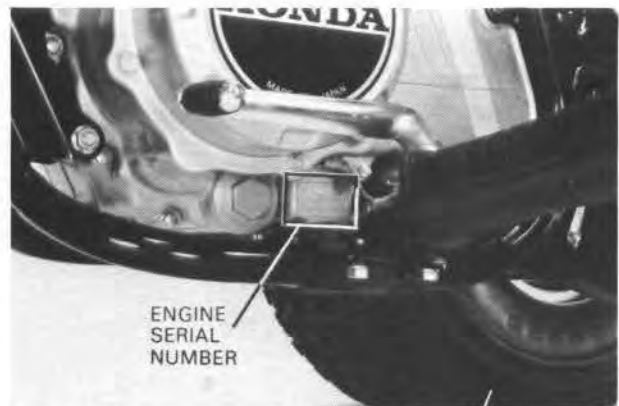

The engine serial number is stamped on the crankcase lower left side.



The carburetor identification number is on the carburetor body right side.



GENERAL SAFETY	1-1
SERVICE RULES	1-1
SPECIFICATIONS	1-2
TORQUE VALUES	1-4
TOOLS	1-6
CABLE & HARNESS ROUTING	1-7
MAINTENANCE SCHEDULE	1-8

## GENERAL SAFETY

### WARNING

*If the engine must be running to do some work, make sure the area is well-ventilated. Never run the engine in a closed area. The exhaust contains poisonous carbon monoxide gas.*

### WARNING

*Gasoline is extremely flammable and is explosive under certain conditions. Do not smoke or allow flames or sparks in your work area.*

## SERVICE RULES

1. Use genuine HONDA or HONDA-recommended parts and lubricants or their equivalent. Parts that don't meet HONDA's design specifications may damage the motorcycle.
2. Use the special tools designed for this product to avoid damage and incorrect assembly.
3. Use only metric tools when servicing this motorcycle. Metric bolts, nuts, and screws are not interchangeable with English fasteners.
4. Install new gaskets, O-rings, cotter pins, and lock plates when reassembling.
5. When tightening bolts or nuts, begin with the larger-diameter or inner bolt first. Then tighten to the specified torque diagonally in 2-3 steps, unless a particular sequence is specified.
6. Clean parts in non-flammable or high flash point solvent upon disassembly.
7. Lubricate any sliding surfaces before reassembly.
8. After reassembly, check all parts for proper installation and operation.



**SPECIFICATIONS**

<p><b>DIMENSIONS</b></p>	<p>Overall length Overall width Overall height Wheel base Rear tread Seat height Foot peg height Ground clearance Dry weight</p>	<p>1,820 mm (71.7 in) 1,110 mm (43.7 in) 995 mm (39.2 in) 1,160 mm (45.7 in) 805 mm (31.5 in) 680 mm (26.8 in) 275 mm (10.8 in) 130 mm (5.1 in) 137 kg (302 lb)</p>
<p><b>FRAME</b></p>	<p>Type Rim size  Front Rear  Front tire size, pressure Rear tire size, pressure Front brake Rear brake Fuel capacity Fuel reserve capacity Caster Trail</p>	<p>Semi-double cradle 10.0 x 9.0 10.0 x 9.0 25 x 12-9, 0.15 kg/cm<sup>2</sup> (2.2 psi) 25 x 12-9, 0.15kg/cm<sup>2</sup> (2.2 psi) Cable operated leading shoe Cable operated leading shoe 8.8 liters (2.3 US gal, 1.9 Imp gal) 1.6 liters (0.42 US gal, 0.35 Imp gal) 70°30' 30 mm (1.2 in)</p>
<p><b>ENGINE</b></p>	<p>Type Cylinder arrangement Bore x stroke Displacement Compression ratio Valve train Maximum horsepower Maximum torque  Oil capacity  Lubrication system Cylinder compression Intake valve  Exhaust valve  Valve clearance (Cold)</p>	<p>Gasoline, air-cooled 4-stroke Single cylinder inclined 15° 63.0 x 57.8 mm (2.48 x 2.28 in) 180.2 cc (11.01 cu in) 8.0:1 Overhead camshaft chain driven 13 BHP/7,000 rpm 1.38 kg-m/5,500 rpm (9.26 ft-lb/5,500 rpm) 1.35 lit (1.43 US qt, 1.19 Imp qt) 0.95 lit (1.00 US qt, 0.84 Imp qt) after draining Forced pressure and wet sump 11 ± 1.0 kg/cm<sup>2</sup> (156 ± 14 psi) 5° BTDC 35° ABDC 35° BBDC 5° ATDC 0.05 mm (0.002 in) 0.05 mm (0.002 in)</p>
<p><b>CARBURETOR</b></p>	<p>Type Main jet Pilot screw opening Float level Idle speed Venturi dia.</p>	<p>Piston valve # 95 2 turns out 12.5 mm (0.49 in) 1,400 ± 100 rpm 22 mm (0.9 in)</p>



DRIVE TRAIN	Clutch Transmission Primary reduction Gear ratio  Final reduction Gearshift pattern Drive chain	Wet multi-plate, semi-automatic 5-speed constant mesh 3.333 2.769 1.722 1.273 1.000 0.815 4.273 Left foot operated return system, N-1-2-3-4-5 520, 90 L
ELECTRICAL	Ignition Ignition timing  Alternator Spark plug    Spark plug gap Headlight Taillight	CDI 10° ± 2° BTDC at idle 30° ± 2° BTDC at 3,350 rpm A. C. generator, 12V 50W/5,000 rpm X24ES-U (ND) D8EA (NGK) X24ESR-U (ND) DR8ES-L (NGK) 0.6-0.7 mm (0.024-0.028 in) 12V 45W/45W 12V (5W)

**GENERAL INFORMATION****TORQUE VALUES****ENGINE**

Item	Q'ty	Thread Size (mm)	Torque	
			kg-m	ft-lb
Cylinder head bolt	4	8 x 1.25	1.8-2.0	13-14
Clutch lock nut	1	16 x 1.0	4.0-5.0	29-36
Centrifugal clutch lock nut	1	22 x 1.25	10.5-11.5	76-83
Clutch adjuster lock nut	1	8 x 1.25	1.9-2.5	14-18
A. C. generator rotor nut	1	12 x 1.25	6.5-7.5	47-54
Valve adjuster cover	2	36 x 1.5	1.0-1.4	7-14
Oil filler cap	1	36 x 1.5	1.0-2.0	7-10
Spark plug	1	12 x 1.25	1.2-1.9	9-14
Cam sprocket bolt	2	6 x 1.0	0.8-1.2	6-9
Oil filter rotor cover bolt	3	6 x 1.0	1.0-1.4	7-10
Clutch lifter stopper bolt	1	8 x 1.25	1.8-2.5	13-18
Gearshift drum stopper arm bolt	1	6 x 1.0	1.0-1.4	7-10
Pulser generator screw	2	5 x 0.5	0.4-0.7	2.9-4.3
Pulser cover screw	2	5 x 0.8	0.4-0.7	2.9-4.3
Valve adjuster lock nut	2	6 x 0.75	1.5-1.8	11-13
Gearshift stopper plate bolt	1	6 x 1.0	0.8-1.2	6-9
Clutch bolt	4	6 x 1.0	1.0-1.4	7-10
Recoil starter driven pulley	4	6 x 1.0	1.0-1.4	7-10
Cam chain tensioner adjust bolt	1	16 x 1.0	1.5-2.2	11-16
Cam chain tensioner check bolt	1	6 x 1.0	0.8-1.0	6-7
Decompressor lever pivot bolt	1	6 x 1.0	0.5-0.7	3.6-5.1
Drive sprocket bolt	3	6 x 1.0	0.8-1.2	6-9
Right crankcase protector screw	3	Self tapping screw	0.3-0.7	2.2-5.1

**FRAME**

Item	Q'ty	Thread Size (mm)	Torque	
			kg-m	ft-lb
Handlebar upper holder bolt	4	6 x 1.0	0.7-1.2	5-9
Handlebar lower holder nut	2	10 x 1.25	4.0-4.8	29-35
Fork top bridge bolt	2	10 x 1.25	4.0-4.8	29-35
Steering stem nut	1	22 x 1.0	5.0-7.0	36-51
Front axle nut	2	12 x 1.25	5.0-7.0	36-51
Front hub nut	4	8 x 1.25	1.9-2.5	14-18
Front brake drum bolt	3	8 x 1.25	1.9-2.5	14-18
Front brake panel bolt	1	8 x 1.25	2.1-2.7	15-20
Front/rear rim nut	12	8 x 1.25	1.9-2.5	14-18
Damper holder nut	5	8 x 1.25	2.1-2.7	15-20
Rear brake drum nut	2	32 x 1.0	6.0-8.0	43-58
Rear hub nut	8	8 x 1.25	1.9-2.5	14-18
Rear axle nut	2	14 x 1.5	6.0-8.0	43-58
Bearing holder bolt	4	12 x 1.25	5.0-7.0	36-51





Item	Q'ty	Thread Size (mm)	Torque	
			kg-m	ft-lb
Front engine hanger nut	2	10 x 1.25	4.0-4.8	29-35
Front engine hanger nut	2	8 x 1.25	2.3-2.7	17-20
Rear engine hanger nut	2	10 x 1.25	4.0-4.8	29-35
Upper engine hanger nut	1	8 x 1.25	1.9-2.5	14-18
Carburetor nut	2	6 x 1.0	0.6-0.9	4.3-6.5
Gearshift pedal	1	6 x 1.0	0.7-1.2	5-8.7
Foot peg bolt	8	8 x 1.25	1.9-2.5	14-18
Mud guard bolt	11	5 x 0.8	0.4-0.8	2.9-5.8
Drive chain slider nut	2	6 x 1.0	0.6-0.9	4.3-6.5

Torque specifications listed above are for the most important tightening points. If a torque specification is not listed, follow the standards given below.

**STANDARD TORQUE VALUES**

Item	Torque kg-m (ft-lb)	Item	Torque kg-m (ft-lb)
5 mm bolt, nut	0.45-0.6 (3.3-4.3)	5 mm screw	0.35-0.5 (2.5-3.6)
6 mm bolt, nut	0.8-1.2 (5.8-8.7)	6 mm screw	0.7-1.1 ( 5-8 )
8 mm bolt, nut	1.8-2.5 ( 13-18 )	6 mm flange bolt, nut	1.0-1.4 (7.2-10)
10 mm bolt, nut	3.0-4.0 ( 22-29 )	8 mm flange bolt, nut	2.4-3.0 ( 17-22 )
12 mm bolt, nut	5.0-6.0 ( 36-43 )	10 mm flange bolt, nut	3.0-4.0 ( 22-29 )

**GENERAL INFORMATION****TOOLS****SPECIAL**

Description	Tool No.	Interchangeability	Ref. Page
Valve guide reamer 5.5 mm	07984-0980000		6-10
Flywheel holder	07925-9580000	Not available in USA	8-5, 8-9, 9-6, 9-8
Clutch center holder	07923-9580000	Not available in USA	8-11, 8-14
41 mm lock nut wrench	07916-9180000	Commercially available	12-5, 12-12
30 mm lock nut wrench	07907-6890100	30 mm socket	8-5, 8-9, 11-18, 11-21
Ball race remover	07944-1150001		11-19
Tire disassembling tool	07772-0010000	M987X-350-XXX	11-11
Lever	07772-0010100	} (Available in USA only)	11-11
Weight	07772-0010200		11-11

**COMMON**

Description	Tool No.	Interchangeability	Ref. Page
Float level gauge	07401-0010000		4-9
Pin spanner	07702-0010000	07902-0010000	11-18, 11-20
Valve adjusting wrench 10 x 12 mm	07708-0030200	} 07908-3230000	3-5
Valve adjuster A	07708-0030300		3-5
Lock nut wrench 20 x 24 mm	07716-0020100	07916-3710000	8-11, 8-14
Lock nut wrench 30 x 32 mm	07716-0020400	07907-6890100	11-18, 11-21
Extension bar	07716-0020500	Commercially available in USA	8-11, 8-14, 11-18, 11-21
Flywheel puller	07733-0010000	07933-0010000	9-6
Valve guide remover 5.5 mm	07742-0010100	07942-3290100	6-10
Valve guide driver B	07742-0020200	07942-3290200	6-10
Bearing driver outer 37 x 40 mm	07746-0010200		11-19
Bearing driver outer 42 x 47 mm	07746-0010300	07946-9350200	11-15
Driver handle outer A	07749-0010000	07949-6110000	11-15, 11-19, 12-10
Driver pilot 15 mm	07746-0040300		11-15
Driver pilot 35 mm	07746-0040800		12-10
Bearing driver inner 20 mm	07746-0020400	07945-8340100	
Driver handle inner B	07746-0020100	07945-8150000	
Bearing driver outer 62 x 68 mm	07746-0010500	07945-3710300	12-9
Valve spring compressor	07757-0010000	07957-3290001	6-8, 6-14



**CABLE & HARNESS ROUTING**

REAR BRAKE CABLE (PARKING BRAKE)

FRONT BRAKE CABLE

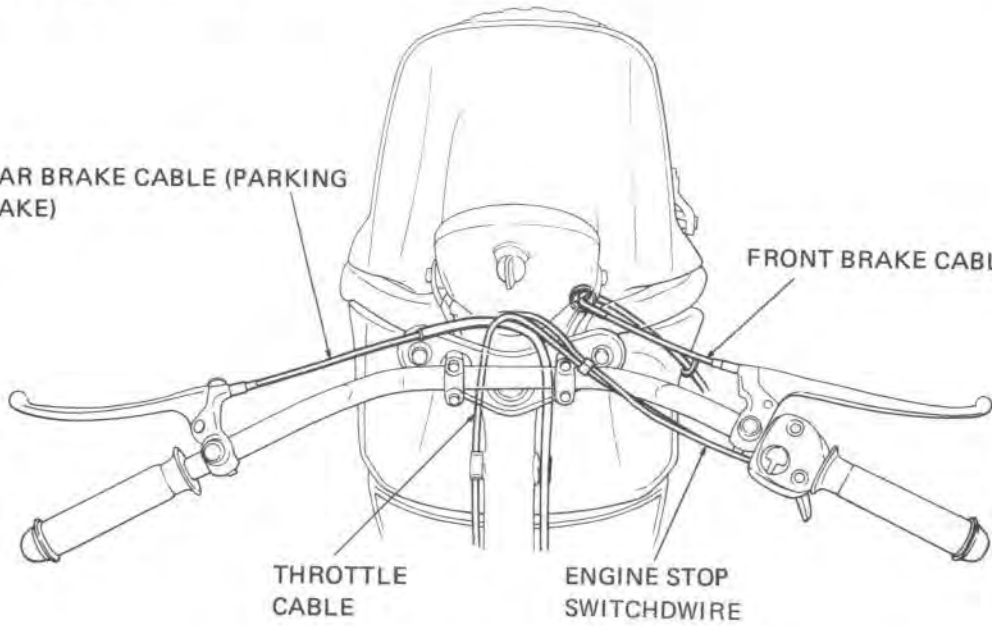

FRONT BRAKE CABLE

REAR BRAKE CABLE

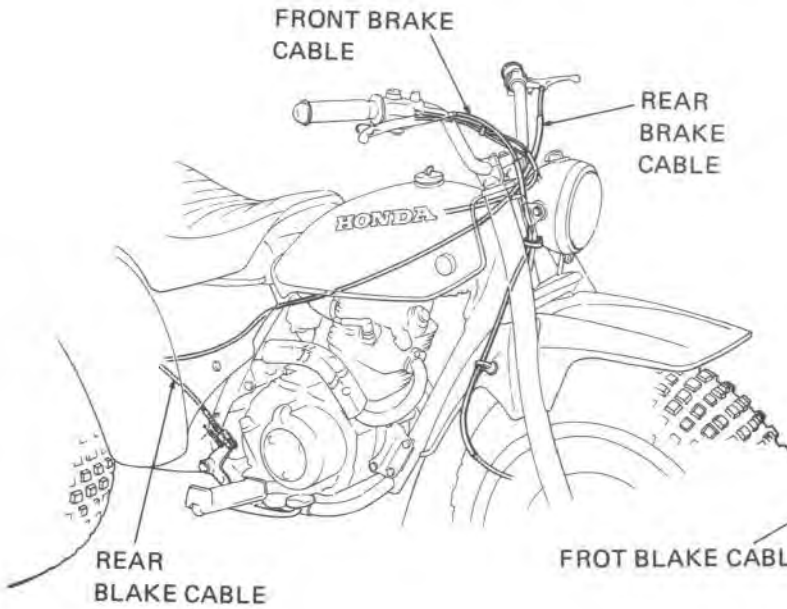

REAR BRAKE CABLE

THROTTLE CABLE

FRONT BRAKE CABLE

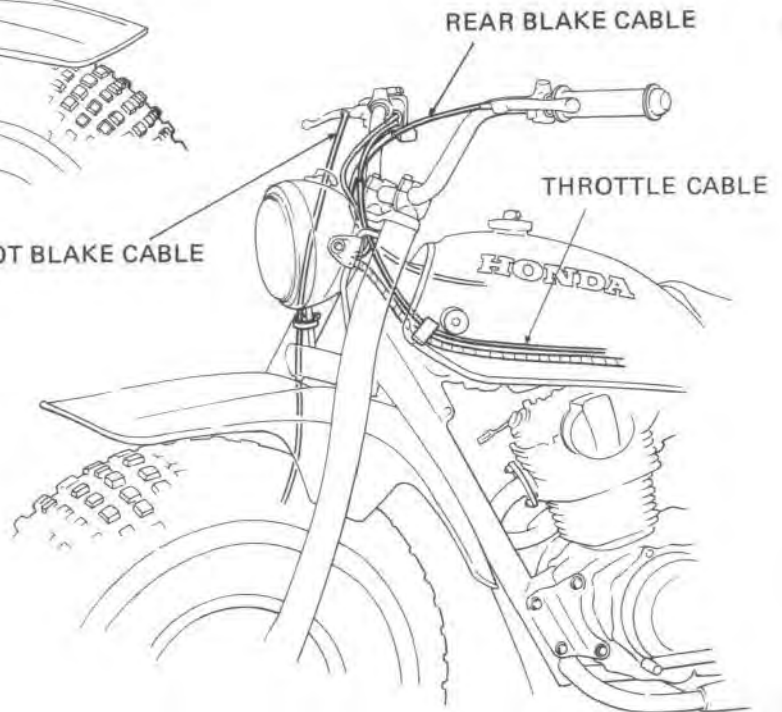



**GENERAL INFORMATION**

**MAINTENANCE SCHEDULE**

Perform the PRE-RIDE INSPECTION in the Owner's Manual at every maintenance period.

**REGULAR MAINTENANCE SCHEDULE**

I : Inspect, Clean, Adjust, Lubricate or Replace if Necessary.

C: Clean

R: Replace

A: Adjust

L: Lubricate

	ITEM	INITIAL SERVICE PERIOD (First week of operation)	REGULAR SERVICE PERIOD (Every 30 operating days)	Ref. Page
	ENGINE OIL (NOTE 1,2)	R	R	2-2
*	ENGINE OIL FILTER SCREEN	C	C	2-2
	OIL FILTER ROTOR		C	2-3
	AIR CLEANER ELEMENT (NOTE 2)		C	3-3
	SPARK PLUG		I	3-4
*	VALVE CLEARANCE	I	I	3-5
*	CAM CHAIN TENSION	A	A	3-6
*	CARBURETOR IDLE SPEED	I	I	3-6
	FUEL LINE	I (EVERY YEAR)		3-6
*	FUEL STRAINER	C (EVERY YEAR)		3-7
	THROTTLE OPERATION	I	I	3-7
	DRIVE CHAIN	I	I	3-9
*	BRAKE SHOES	I (EVERY YEAR)		3-11
	BRAKE CONTROL LINKAGE	I	I	3-11
*	CLUTCH	I	I	3-13
*	SPARK ARRESTER		C	3-13
	ALL NUTS, BOLTS, FASTENERS	I	I	3-14
	LIGHTING EQUIPMENT	I	I	3-14
	TIRES	I	I	3-14
*	STEERING HEAD BEARING	A (EVERY YEAR)		3-15

NOTES: 1. Replace every 30 operating days or every 3 months, whichever occurs first.

2. Service more frequently when riding in dusty areas.



**HONDA**  
**ATC185**

---

MEMO

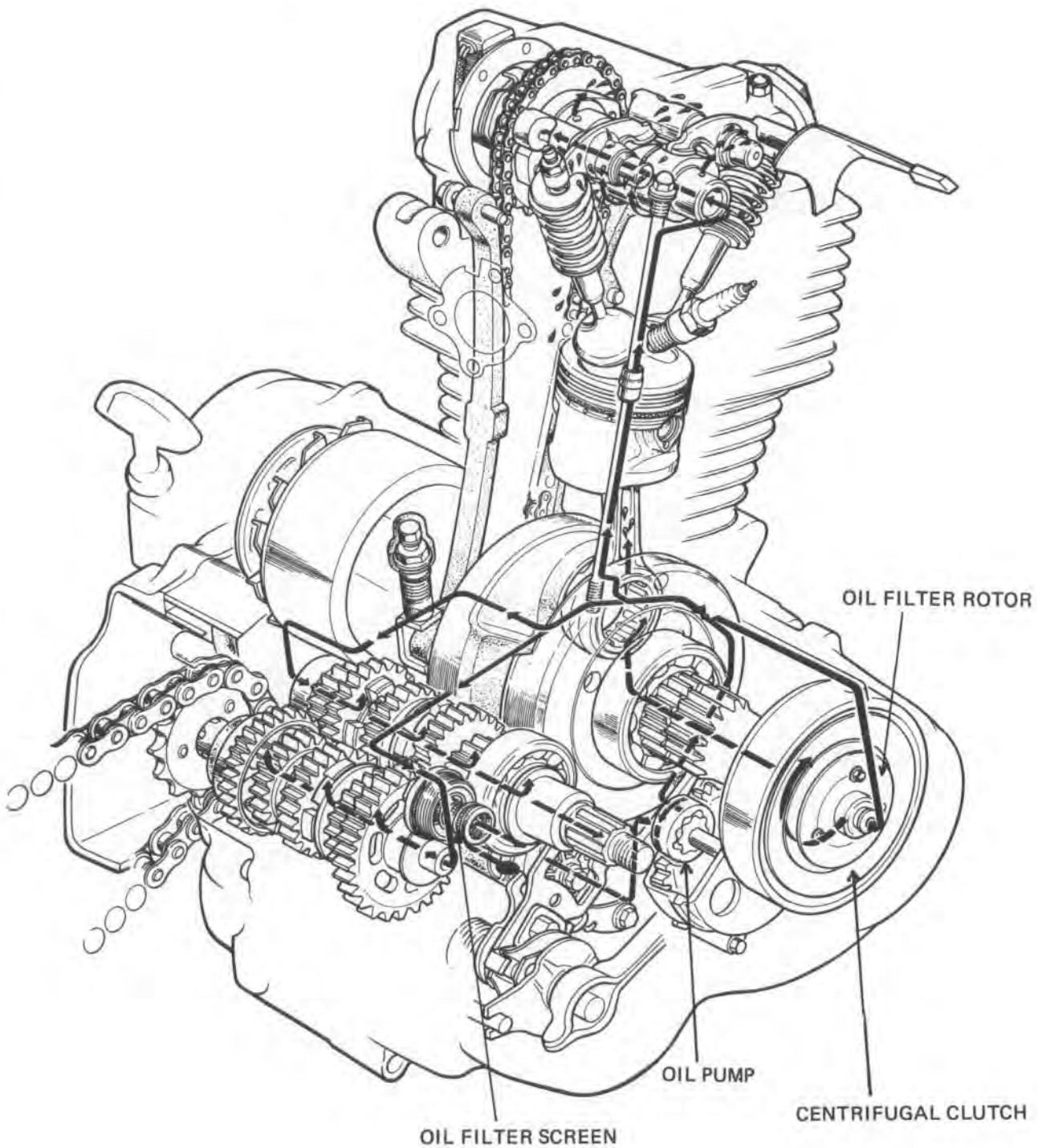



SERVICE INFORMATION	2-1
TROUBLESHOOTING	2-1
ENGINE OIL LEVEL CHECK	2-2
ENGINE OIL CHANGE AND OIL FILTER SCREEN CLEANING	2-2
OIL FILTER ROTOR CLEANING	2-3
LUBRICATION POINTS	2-4

## SERVICE INFORMATION

### GENERAL INSTRUCTIONS

- This section describes how to inspect and replace the engine oil and clean the oil filter screen.
- Section 8 shows how to service the oil pump.

### SPECIFICATIONS

Oil capacity 1.35 lit (1.43 US qt, 1.19 Imp qt) at disassembly  
0.95 lit (1.00 US qt, 0.84 Imp qt) at draining

Engine oil recommendation

Use HONDA 4-STROKE OIL or equivalent.  
API SERVICE CLASSIFICATION: SE  
Viscosity: SAW 10W-40

### TORQUE VALUES

Oil filter screen cap 1.0-2.0 kg-m (7-14 ft-lb)  
Oil filter rotor cover bolt 1.0-1.4 kg-m (7-10 ft-lb)

## TROUBLESHOOTING

### Oil level too low

1. Normal oil consumption
2. External oil leaks
3. Worn piston rings

### Oil consumption

1. Oil not changed often enough
2. Faulty head gasket

### OIL VISCOSITY

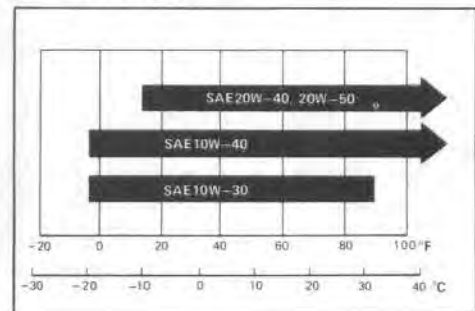



## ENGINE OIL LEVEL CHECK

Place the ATC on level ground.  
 Check the oil level with the oil cap/dipstick.  
 Do not screw in the cap when making this check.

If the oil level is below the lower level mark on the dipstick, fill to the upper level mark with the recommended oil (Page 2-1).

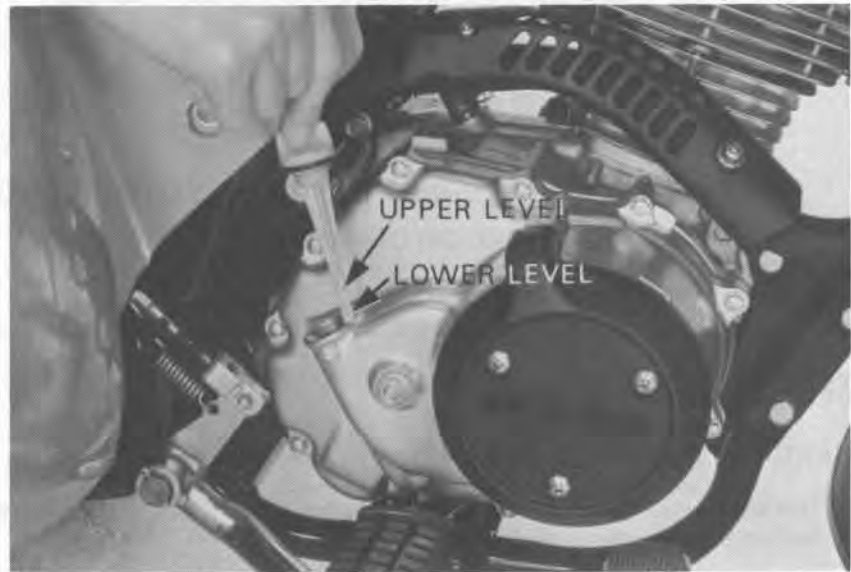

## ENGINE OIL CHANGE AND OIL FILTER SCREEN CLEANING

### NOTE

- Drain the oil with the engine warm.
- The oil filter screen and spring will come out when the oil filter screen cap is removed.

Remove the oil filler cap and oil filter screen cap.

Operate the recoil starter several times to completely drain any residual oil.  
 Clean the oil filter screen.

Make sure that the oil filter screen, sealing rubber, screen cap and O-ring are in good condition.

Install the oil filter screen, spring and screen cap.

**TORQUE: 1.0–2.0 kg-m (7–14 ft-lb)**

Fill the crankcase with the recommended grade oil (Page 2-1).

### ENGINE OIL CAPACITY:

**0.95 liters (1.00 US qt, 0.84 Imp qt)**  
 after draining

Install the oil filler cap.

Start the engine and let it idle for 2-3 minutes.  
 Stop the engine.

With the ATC on level ground, make sure that the oil level is at the upper level mark.  
 Be sure there are no leaks.

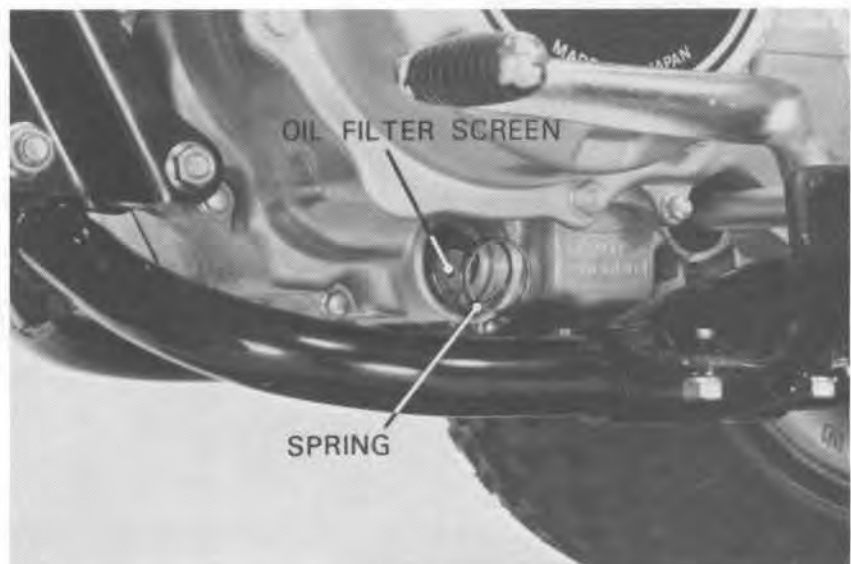





## OIL FILTER ROTOR CLEANING

### NOTE

Clean the oil filter rotor before adding oil.

Remove the right crankcase cover (Page 8-3).

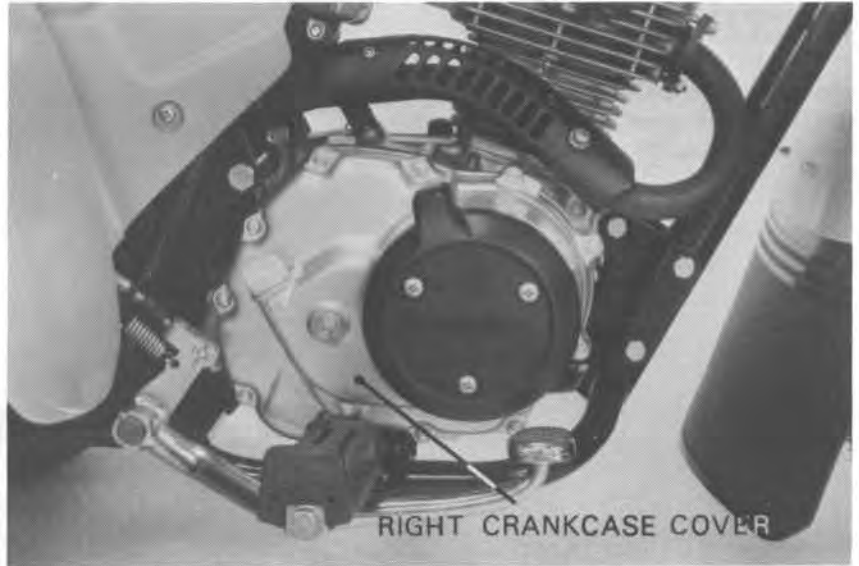

Remove the oil filter rotor cover and clean the inside of the rotor cover and rotor.

Install the oil filter rotor cover (Page 8-10).

**TORQUE: 1.0-1.4 kg-m (7-10 ft-lb)**

Install the right crankcase cover (Page 8-21).  
Fill the engine with recommended grade oil (Page 2-1 and 2-2).





## LUBRICATION POINTS

Use general purpose grease when no other specification is given. Apply oil or grease to any 2 sliding surfaces and cables not shown here.

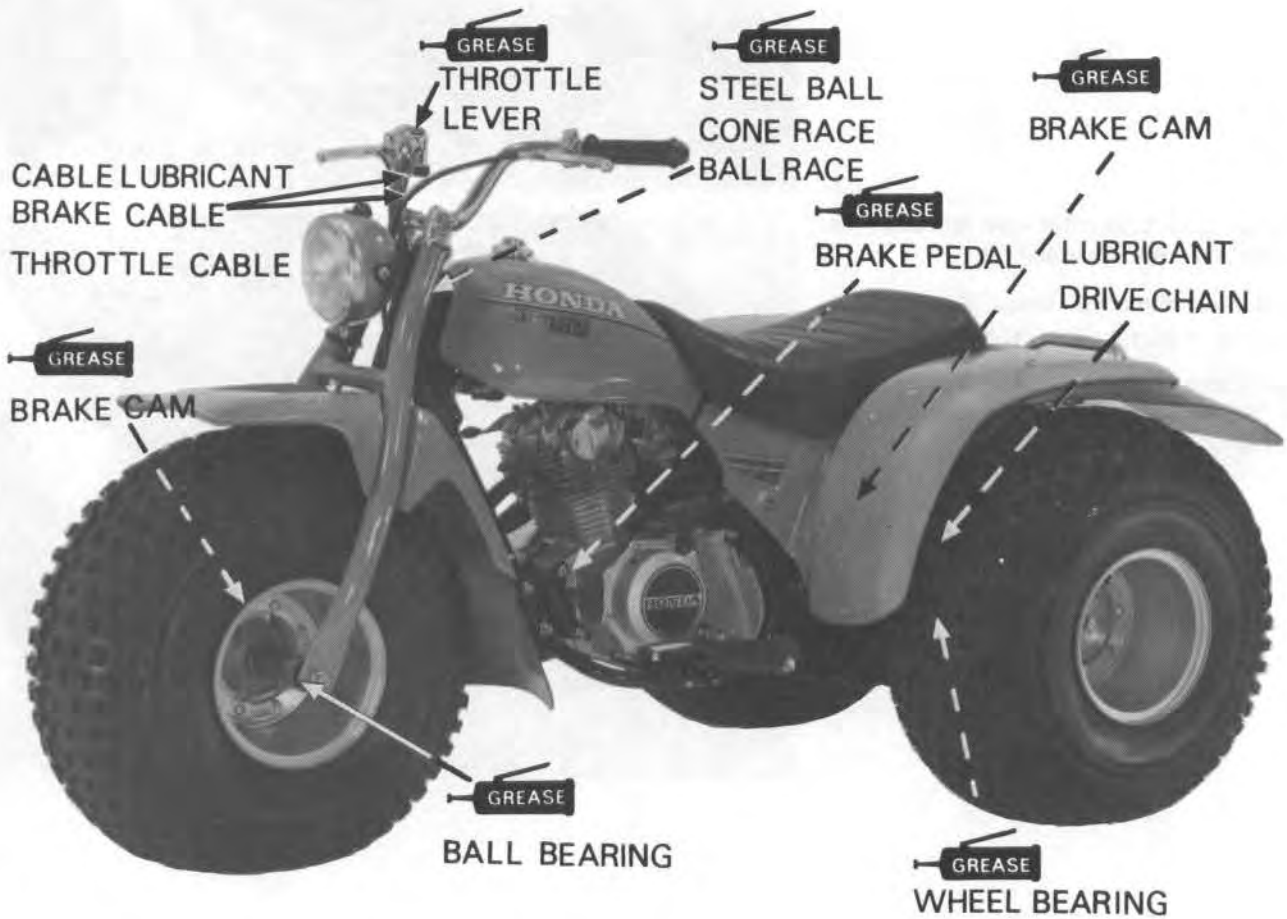



SERVICE INFORMATION	3-1	< CHASSIS >	
< ENGINE >		DRIVE CHAIN	3-9
AIR CLEANER	3-3	BRAKE SHOES	3-11
SPARK PLUG	3-4	FRONT BRAKE	3-11
VALVE CLEARANCE	3-5	REAR BRAKE	3-12
CAM CHAIN TENSION	3-6	CLUTCH	3-13
CARBURETOR IDLE SPEED	3-6	SPARK ARRESTER CLEANING	3-13
FUEL LINE	3-6	NUTS, BOLTS, FASTENERS	3-14
FUEL STRAINER	3-7	LIGHTING EQUIPMENT	3-14
THROTTLE OPERATION	3-7	TIRES	3-14
IGNITION TIMING	3-8	STEERING HEAD BEARING	3-15
CYLINDER COMPRESSION	3-8		

## SERVICE INFORMATION

### SPECIFICATIONS

#### < ENGINE >

##### Ignition timing:

Initial                       $10^{\circ} \pm 2^{\circ}$  BTDC at idle  
Full advance                 $30^{\circ} \pm 2^{\circ}$  BTDC at 3,350 rpm

##### Spark plug:

Spark plug gap             0.6-0.7 mm (0.024-0.028 in)

##### Recommended spark plugs:

USA model                    X24ES-U     (ND)  
                                      D8EA         (NGK)

Canada model                X24ESR-U    (ND)  
                                      DR8ES-L     (NGK)

##### Valve clearance: (cold)

Intake                         0.05 mm (0.002 in)  
Exhaust                        0.05 mm (0.002 in)

##### Throttle lever free play

5-10 mm (3/16-3/8 in)

##### Idle speed

$1,400 \pm 100$  rpm

##### Cylinder compression

$11 \pm 1$  kg/cm<sup>2</sup> (156  $\pm$  14 psi)



**INSPECTION/ADJUSTMENT**

**<CHASSIS >**

Front brake lever free play	15-20 mm (5/8-3/4 in)
Rear brake pedal free play	15-20 mm (5/8-3/4 in)
Rear brake lever (parking brake) lever free play	15-20 mm (5/8-3/4 in)
Drive chain free play	10-20 mm (3/8-3/4 in)
Drive chain length (45 pins):	
Standard	698.5 mm (27.50 in)
Service limit	715 mm (28.1 in)
Front/rear rim size	10.0 x 9.0
Front/rear tire size	25 x 12-9.0
Front/rear tire pressure	0.15 kg/cm <sup>2</sup> (2.2 psi)
Front/rear tire circumference	
Standard	1,963 mm (77.28 in)

**TORQUE VALUES**

Spark plug	1.2-1.9 kg-m (9-14 ft-lb)
Valve adjuster cover	1.0-2.0 kg-m (7-14 ft-lb)
Cam chain tensioner adjusting bolt	1.5-2.2 kg-m (11-16 ft-lb)
Rear axle bearing holder bolt	5.0-7.0 kg-m (36-51 ft-lb)
Clutch adjusting screw lock nut	1.9-2.5 kg-m (14-18 ft-lb)
Valve adjusting screw lock nut	1.5-1.8 kg-m (11-13 ft-lb)



## AIR CLEANER

Remove the seat.

Remove the air cleaner case cover.

Remove the air cleaner case attaching bolts and loosen the air cleaner connecting tube band.

Remove the air cleaner case.

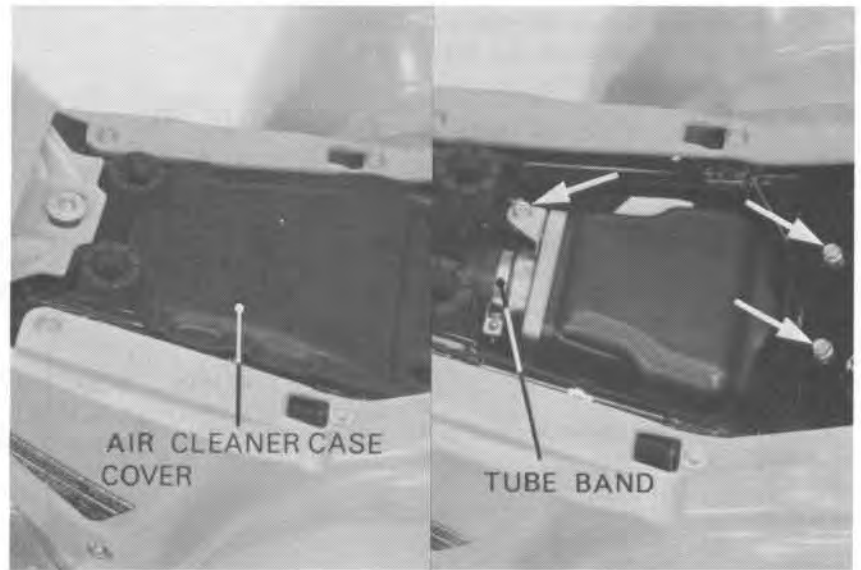

Remove the nut and the air cleaner element from the air cleaner case.



Remove the retainer and air cleaner element from the element holder.

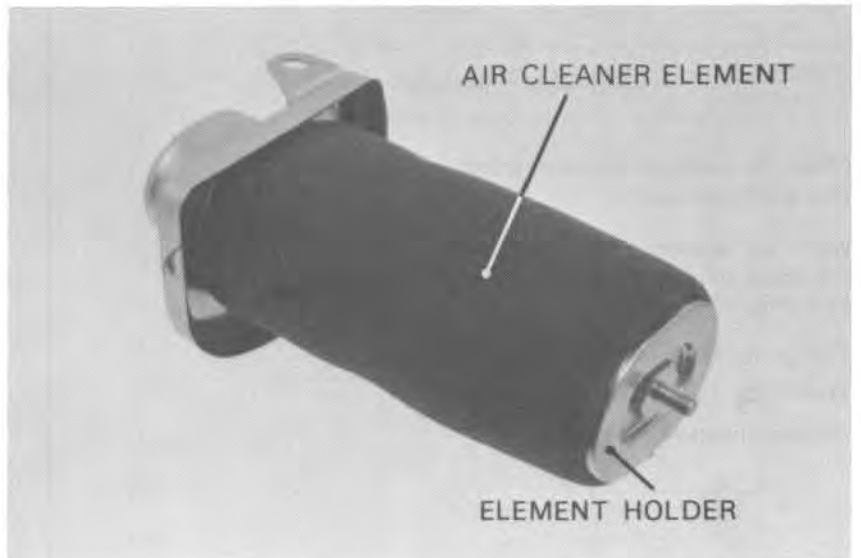



## INSPECTION/ADJUSTMENT

Wash the element in non-flammable or high flash point solvent, squeeze out the solvent thoroughly, and allow to dry.

Soak the element in gear oil (SAE 80-90) and squeeze out excess. Place the element onto the element holder.

Install the element holder into the air cleaner case.

Install the air cleaner case and attach the connecting tube.

Tighten the tube band.

Install the air cleaner case cover and seat.

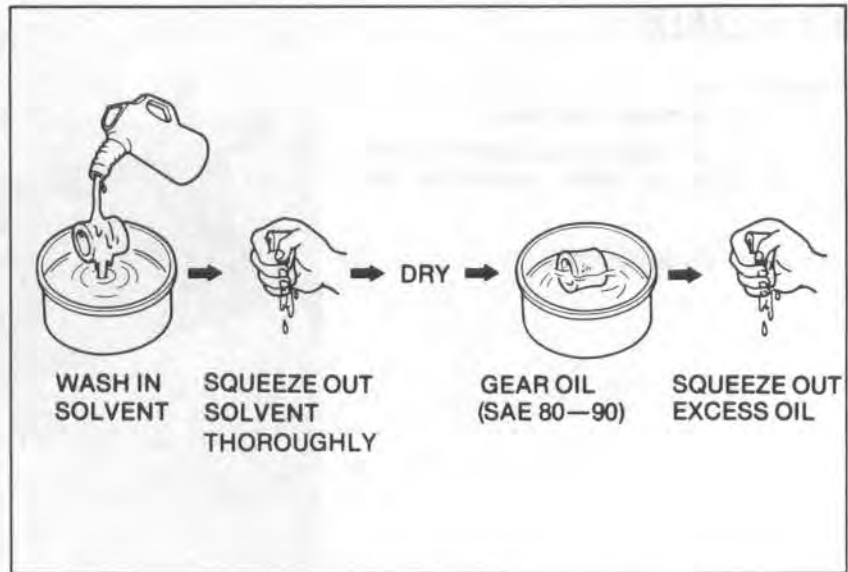

## SPARK PLUG

Disconnect the spark plug cap and remove the spark plug.

Visually inspect the spark plug electrodes for wear. The center electrode should have square edges and the side electrode should have a constant thickness. Discard the spark plug if there is apparent wear or if the insulator is cracked or chipped. Measure the gap with a wire-type feeler gauge and adjust by carefully bending the side electrode.

### SPARK PLUG GAP:

0.6-0.7 mm (0.024-0.028 in)

### RECOMMENDED REPLACEMENT PLUG:

	NGK	ND
USA model	D-8EA	X24ES-U
Canada model	DR8ESR-L	X24ESR-U

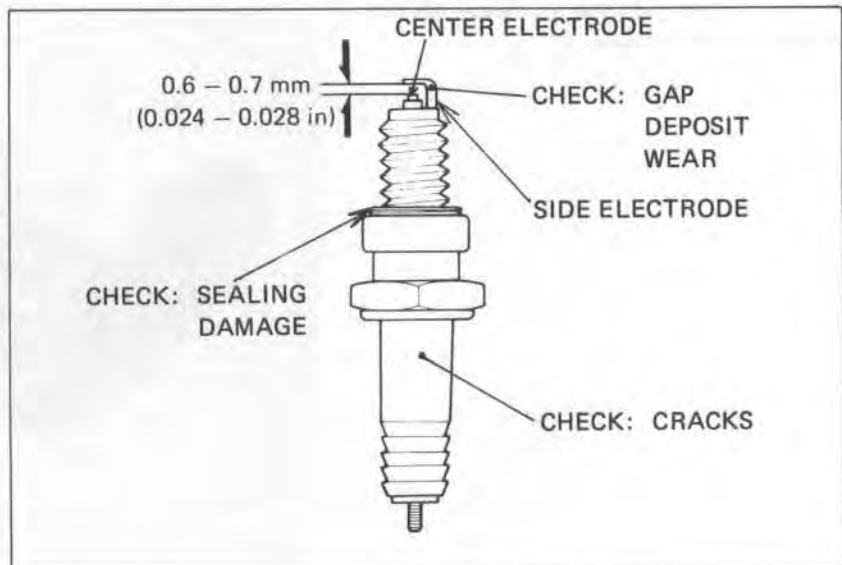

Check the sealing washer and replace with a new one if damaged.

With the sealing washer attached, thread the spark plug in by hand to prevent cross-threading.

Tighten the spark plug to the specified torque.

**TORQUE: 1.2-1.9 kg-m (9-14 ft-lb)**

Connect the spark plug cap.



## VALVE CLEARANCE

### NOTE

- Inspect and adjust valve clearance while the engine is cold (below 35°C/95°F).
- Make sure the decompressor valve lifter has free play.

Remove the seat and fuel tank.  
Remove the timing mark hole cap.  
Remove the valve adjuster covers.

Rotate the crankshaft by using the recoil starter and align the "T" mark on the rotor with the index mark. The piston must be at TDC of the compression stroke.

Inspect the intake and exhaust valve clearances by inserting the feeler gauge between the adjusting screw and valve stem.

### VALVE CLEARANCES:

Intake: 0.05 mm (0.002 in)  
Exhaust: 0.05 mm (0.002 in)



Adjust by loosening the lock nut and turning the adjusting screw until there is a slight drag on the feeler gauge.

Hold the adjusting screw and tighten the lock nut.

**TORQUE: 1.5–1.8 kg-m (11–13 ft-lb)**

Recheck the valve clearance.  
Install the valve adjuster covers.

**TORQUE: 1.0–2.0 kg-m (7–14 ft-lb)**

Install the timing hole cap.  
Install the fuel tank and the seat.  
Reconnect the fuel tube.

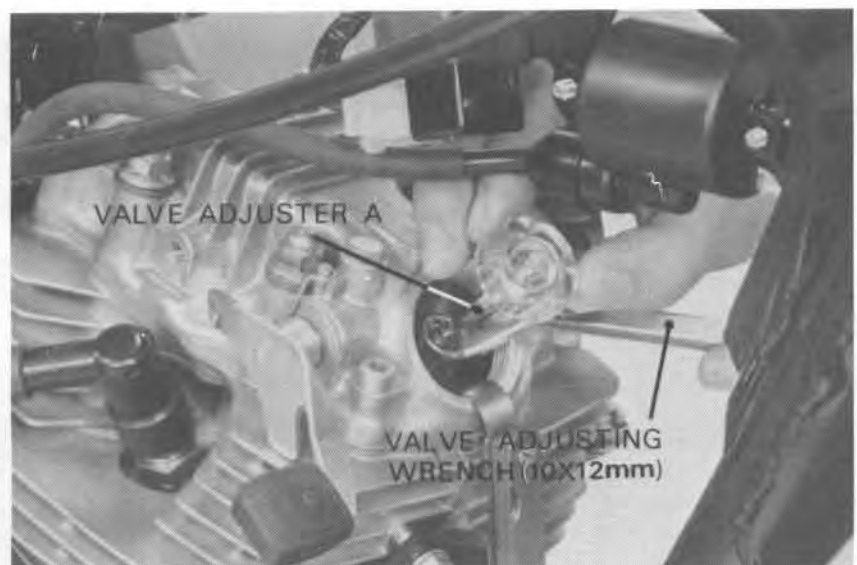



**INSPECTION/ADJUSTMENT**

**CAM CHAIN TENSION**

Start the engine and allow it to idle.  
Remove the rubber cap and loosen the cam chain tensioner adjusting bolt.

When the cam chain tensioner adjusting bolt is loosened, the tensioner will automatically position itself to provide the correct tension.

Retighten the adjusting bolt and install the rubber cap.

**TORQUE: 1.5–2.2 kg-m (11–16 ft-lb)**

**NOTE**

Do not loosen the 6 mm bolt.

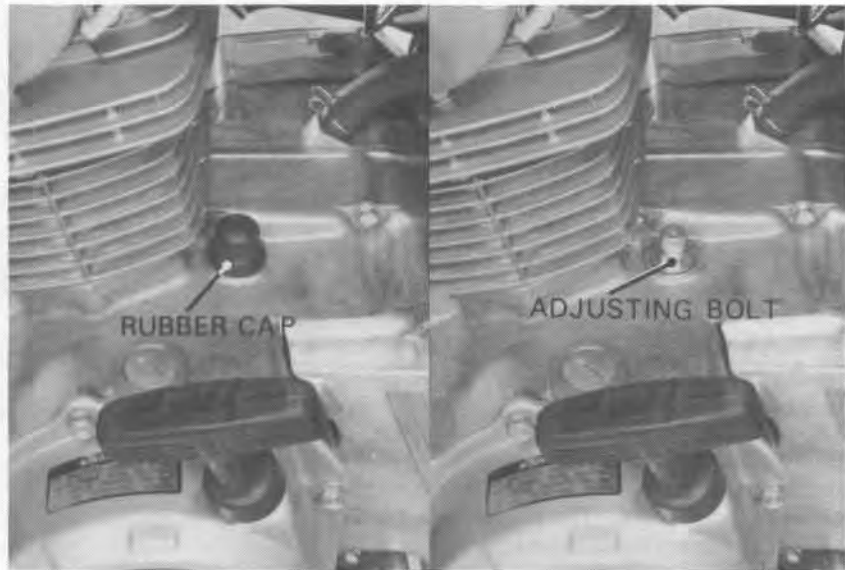

**CARBURETOR IDLE SPEED**

**NOTE**

- Inspect and adjust the idle speed after all other maintenance items have been performed and are within specifications.
- The engine must be warm for accurate idle speed inspection and adjustment.

Warm up the engine.  
Stop and go driving for ten minutes is sufficient.

Turn the throttle stop screw as required to obtain the specified idle speed.

**IDLE SPEED: 1,400 ± 100 rpm**

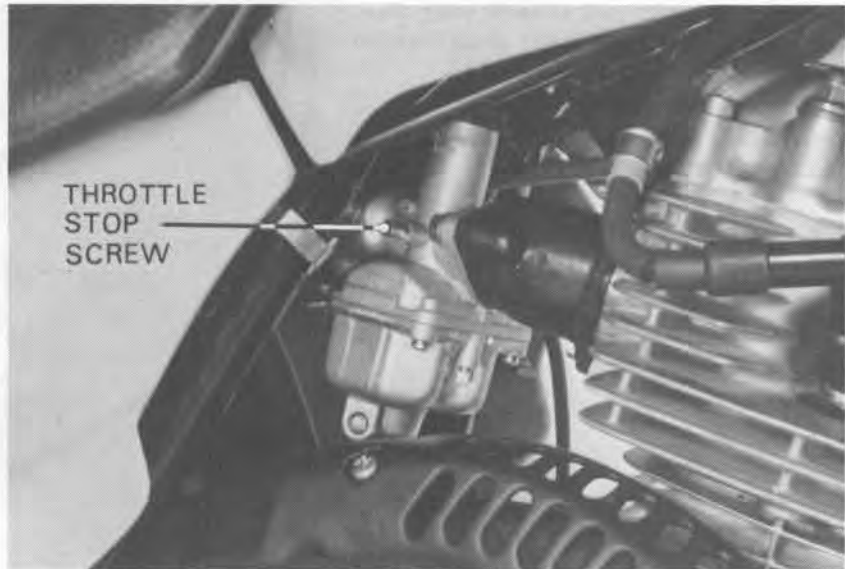

**FUEL LINE**

Replace any parts which show signs of deterioration, damage or leaks.







## FUEL STRAINER

Disconnect the fuel tube.  
Drain fuel from the fuel tank.

**WARNING**

*Keep gasoline away from flames or sparks. Wipe up spilled gasoline at once.*

Remove the fuel valve by loosening the valve nut.

Remove the fuel strainer and clean the strainer.

Install the strainer and valve.  
Attach the fuel line.

Fill the fuel tank and turn the fuel valve "ON" and check for leaks.



## THROTTLE OPERATION

Check for smooth throttle lever full opening and automatic full closing in all steering positions.

Make sure there is no deterioration, damage or kinking in the throttle cable.  
Replace any damaged parts.

Disconnect the throttle cable at the upper end. Thoroughly lubricate the cable and pivot point with a commercially available cable lubricant to prevent premature wear.

Install the throttle cable in the reverse order of removal.

Make sure the throttle lever free play is 5-10 mm (3/16-1/8 in) at the tip of the throttle lever.

Adjust as follows:

Remove the fuel tank.

Slide the rubber cap of the adjuster on the carburetor top up.

Adjust the throttle lever free play by turning the adjuster on the carburetor.

Install the adjuster rubber cap securely.  
Install the fuel tank.

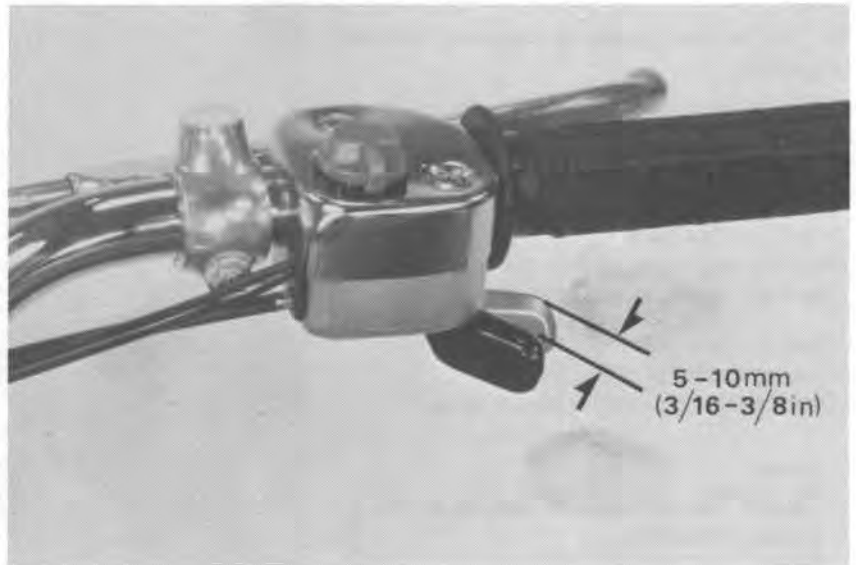



**INSPECTION/ADJUSTMENT**

**IGNITION TIMING**

**NOTE**

The Capacitive Discharge Ignition (CDI) system is factory pre-set and does not require adjustment. To inspect the function of the CDI components, ignition timing inspection procedures are given here.

Remove the timing hole cap.  
Connect a tachometer and timing light.  
Start the engine and allow it to idle.

**IDLE SPEED: 1,400 ± 100 rpm**

Inspect the ignition timing.  
Timing is correct, if the "F" mark on the generator rotor is aligned with the index mark on the left crankcase cover at idle.

If the ignition timing is incorrect, refer to Page 14-4.



**CYLINDER COMPRESSION**

Warm up the engine.  
Stop the engine and remove the spark plug.  
Insert a compression gauge.

Raise the choke lever all the way up.  
Fully open the throttle.  
Operate the recoil starter several times.

**NOTE**

Watch for compression leaking at the gauge connection.

**COMPRESSION: 11 ± 1 kg/cm<sup>2</sup>  
(156 ± 14 psi)**

**Low compression can be caused by:**

- Improper valve adjustment
- Valve leakage
- Cylinder head gasket leaking
- Worn piston ring or cylinder

**High compression can be caused by:**

- Carbon deposits in combustion chamber or on piston crown





## DRIVE CHAIN

Stop the engine and shift the transmission into neutral.

Remove the drive chain inspection hole cap.

Check the amount of chain free play through the inspection hole.

**DRIVE CHAIN FREE PLAY: 10–20 mm**  
**(3/8–3/4 in)**

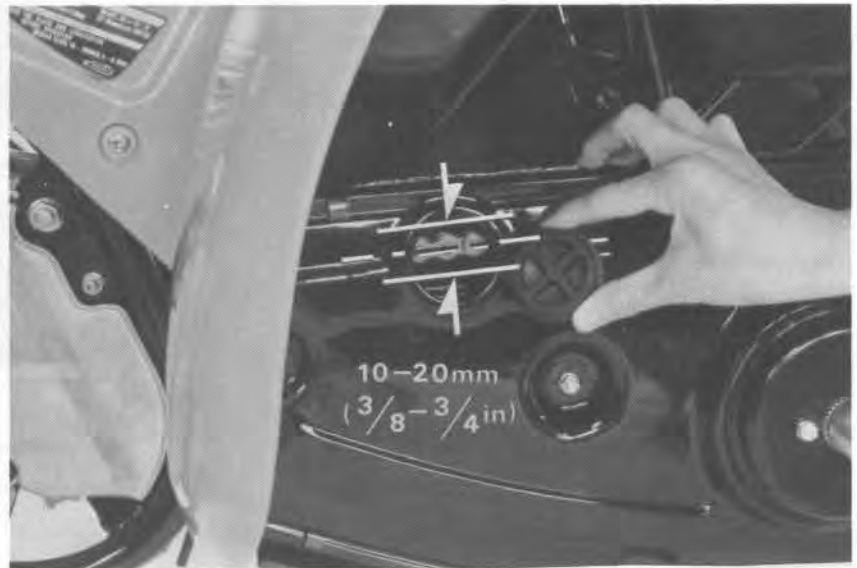

### Adjust as follows:

Loosen the rear axle bearing holder bolts.  
Turn the adjusting nut to obtain the specified free play.

Retighten the rear axle bearing holder bolts.

Check the rear wheels for free rotation.  
Adjust the rear brake (Page 3–12).

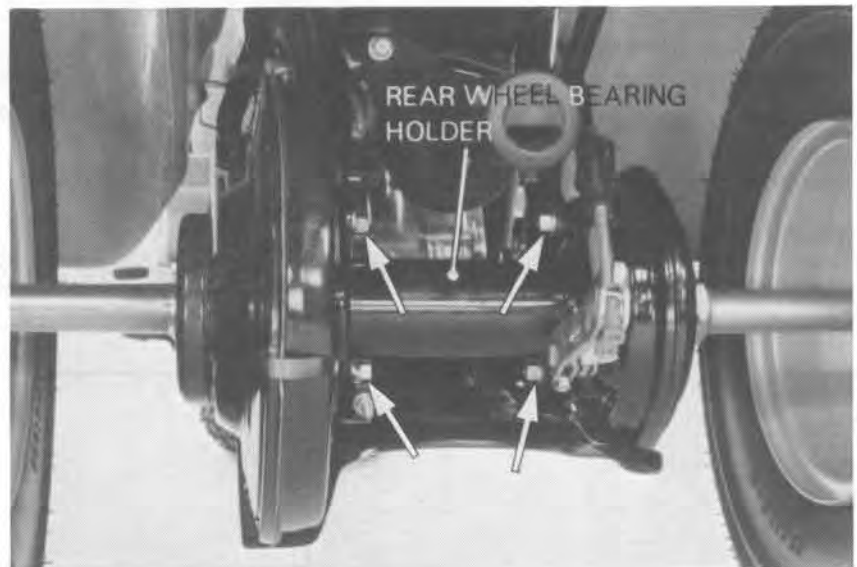

Lubricate the drive chain with a commercial chain lubricant through the inspection hole.

Install the inspection hole cap.





**INSPECTION/ADJUSTMENT**

When the drive chain becomes extremely dirty, it should be removed and cleaned prior to lubrication.

Remove the frame under cover.  
Remove the drive sprocket cover.

Remove the sealed cover and drive chain cover.  
Remove the drive chain.

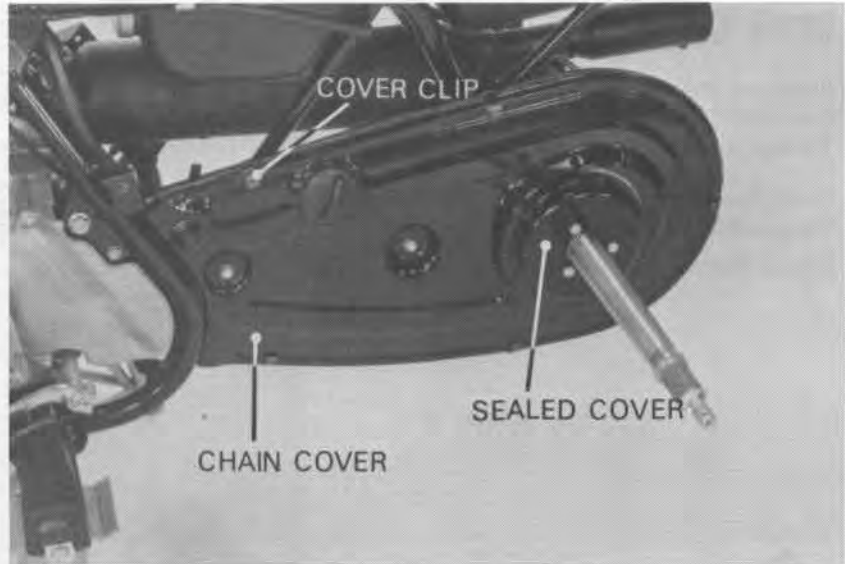

Clean the drive chain in non-flammable or high flash point solvent with a brush and allow it to dry.

Inspect the drive chain for wear or damage.  
Replace any chain that is excessively worn or damaged.

Measure the drive chain distance between a span of 45 pins from pin center to pin center with the chain held taut and any kinks straightened.

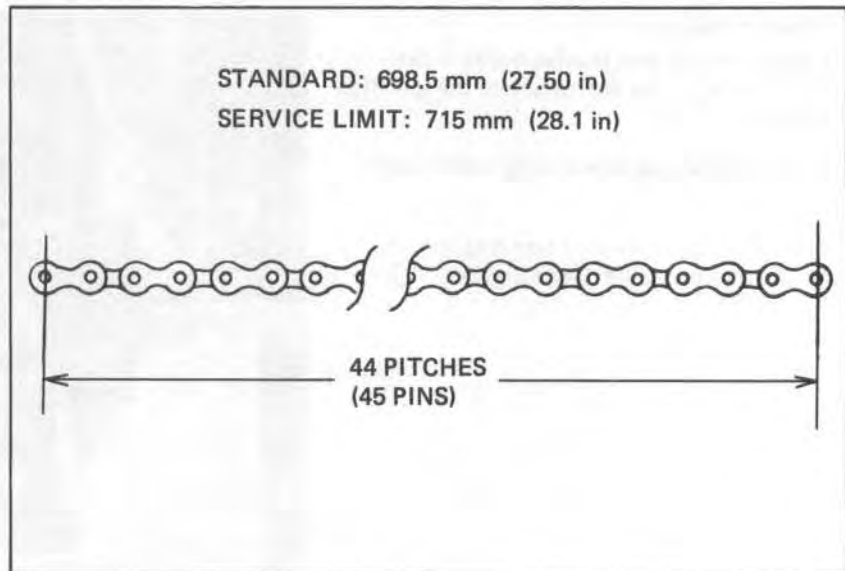

Inspect the drive sprocket teeth for excessive wear or damage.  
Replace if necessary.

**NOTE**

Never install a new drive chain on worn sprockets or a worn chain on new sprockets. Both chain and sprockets must be in good condition, or the new replacement chain or sprockets will wear rapidly.

Install the drive chain in the reverse order of removal noting the chain clip direction (Page 12-13).

Lubricate the drive chain with a commercial chain lubricant.

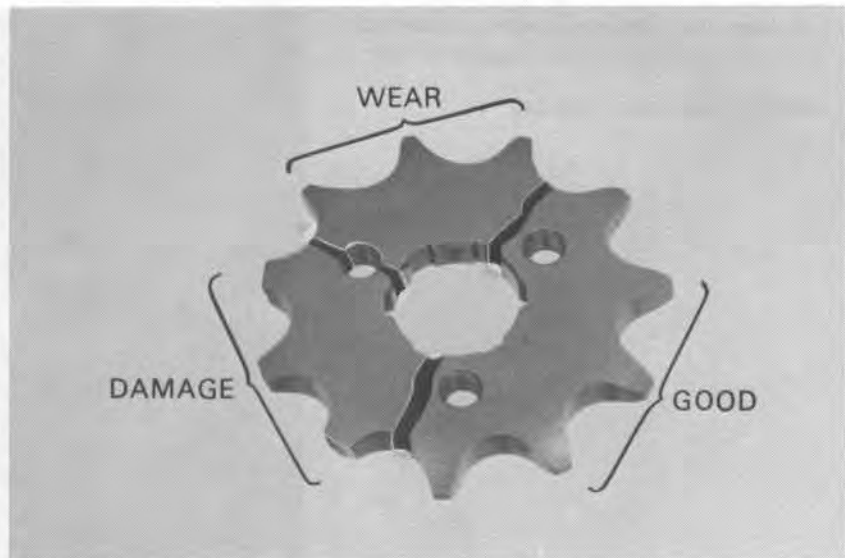



## BRAKE SHOES

Replace the brake shoes if the indicator plate aligns with the brake panel index mark when the front brake lever, rear brake lever or pedal is applied.

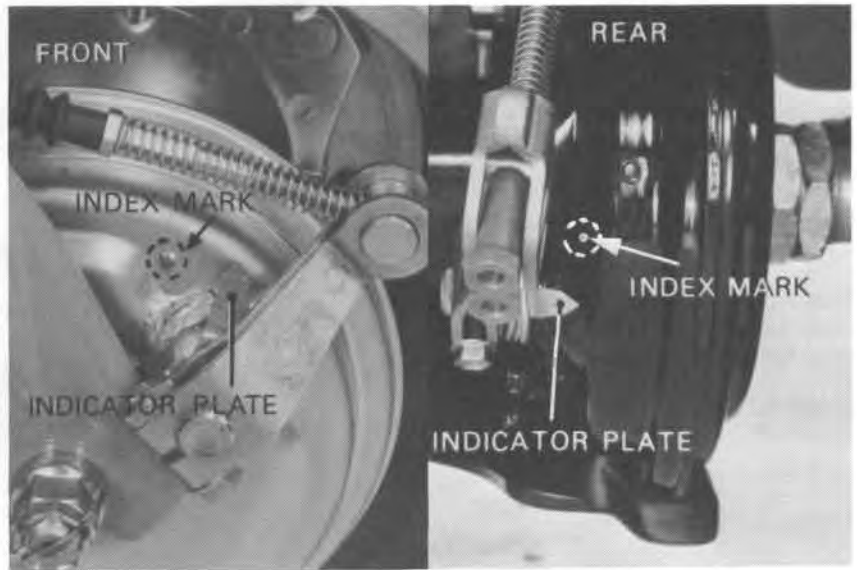

## FRONT BRAKE

Check the cable and brake lever for loose connections, excessive play, or other damage. Replace or repair if necessary.

Disconnect the brake cable at the upper end. Thoroughly lubricate the cable and pivot point with a commercially available cable lubricant to prevent premature wear.

Install the brake cable. Make sure brake lever free play is 15–20 mm (5/8–3/4 in) at the brake lever tip.

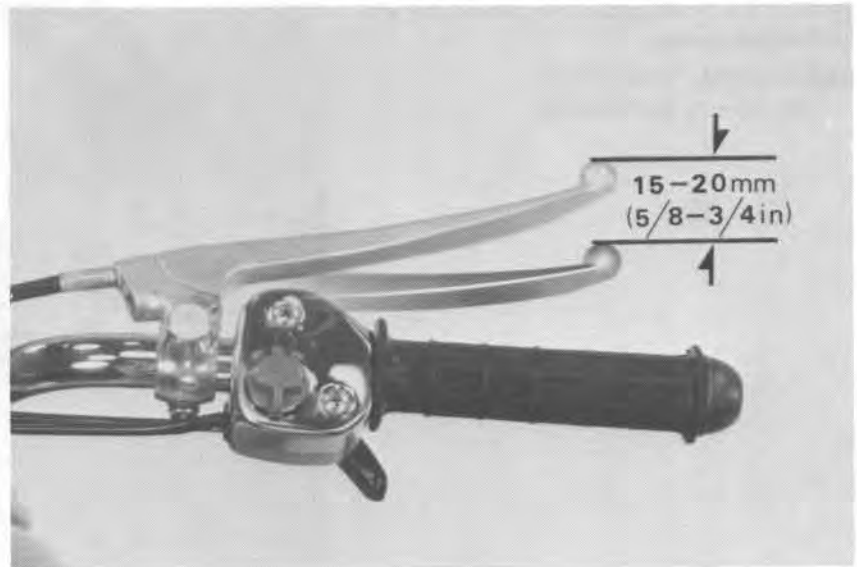

Adjust free play by turning the adjusting nut.

### NOTE

Make sure the cut-out of the adjusting nut is seated on the brake arm pin.





**INSPECTION/ADJUSTMENT**

**REAR BRAKE**

Check the cable, brake lever and brake pedal for loose connections, excessive play, or other damage.

Replace or repair if necessary.

Disconnect the brake cables at the brake lever or pedal ends.

Thoroughly lubricate the cables and their pivot points with a commercially available cable lubricant to prevent premature wear.

Install the cables.

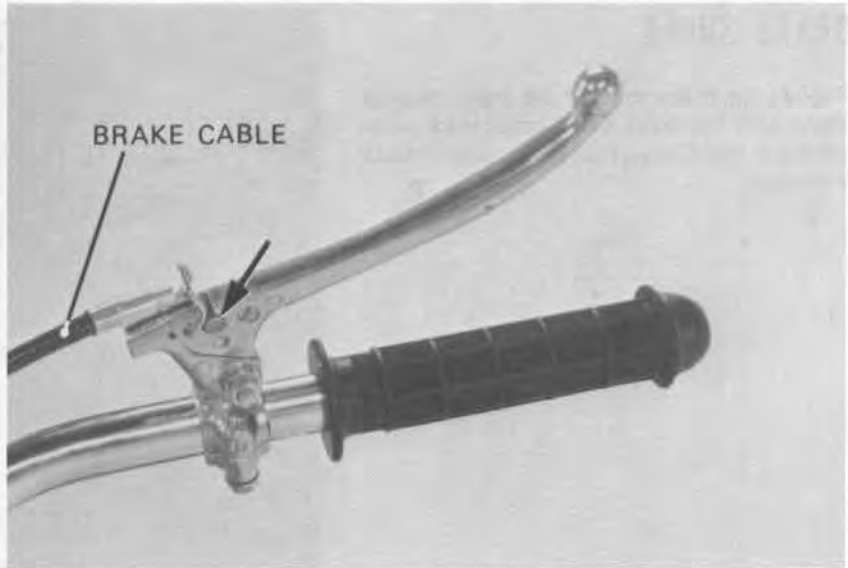

Measure the brake pedal free play at the end of the brake pedal.

**BRAKE PEDAL FREE PLAY:**  
15-20 mm (5/8-3/4 in)

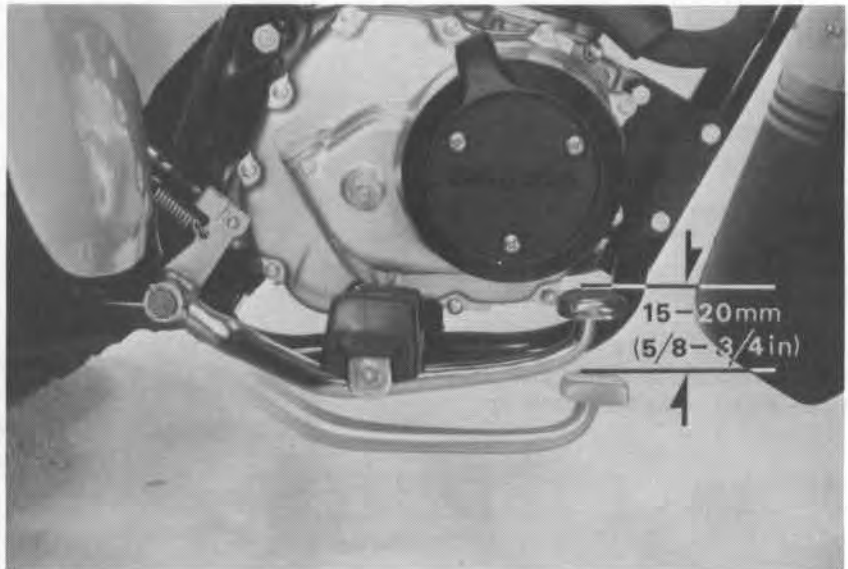

Measure the rear brake lever (parking brake) free play at the end of the brake lever.

**REAR BRAKE LEVER FREE PLAY:**  
15-20 mm (5/8-3/4 in)

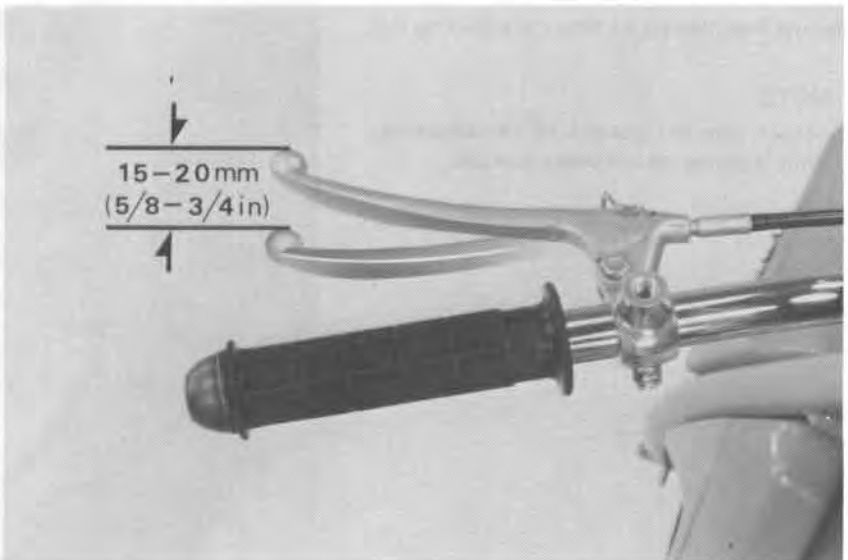



Adjust the free play by turning the adjuster.

### NOTE

Make sure the cut-out of the adjuster is seated on the brake arm pin.



## CLUTCH

Stop the engine.

Loosen the clutch adjusting screw lock nut.

Slowly turn the adjusting screw counterclockwise until resistance is felt.

Then turn the adjusting screw clockwise 1 / 8 turn, and tighten the lock nut.

After adjustment, start the engine and check for proper clutch operation.

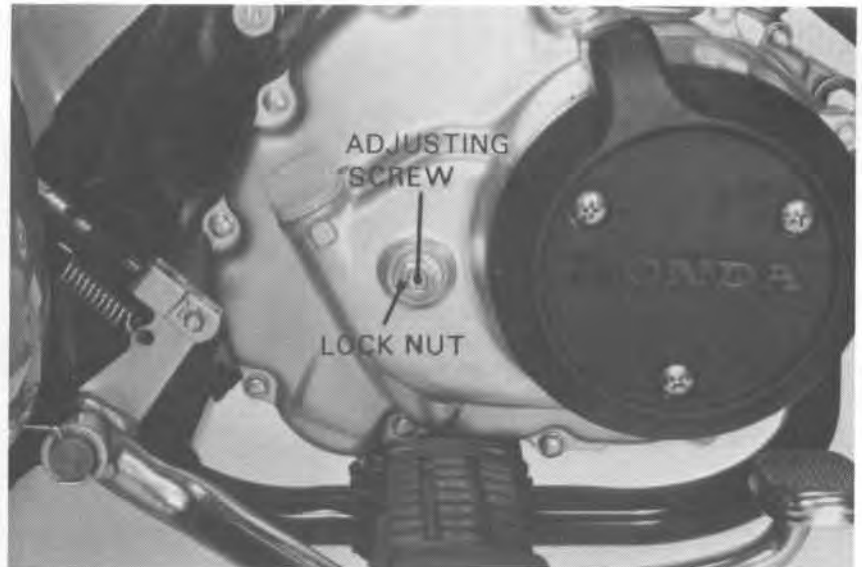

## SPARK ARRESTER CLEANING

### WARNING

- Do not remove and install the spark arrester while the exhaust pipe is hot.
- Perform this operation in a well-ventilated area, free from fire hazard.
- Use adequate eye protection.

Remove the spark arrester bolts.

Remove the spark arrester.

Remove any arrester accumulated carbon.

Start the engine and remove accumulated carbon from the exhaust system by momentarily revving up the engine several times.

Stop the engine.

Reinstall the spark arrester.

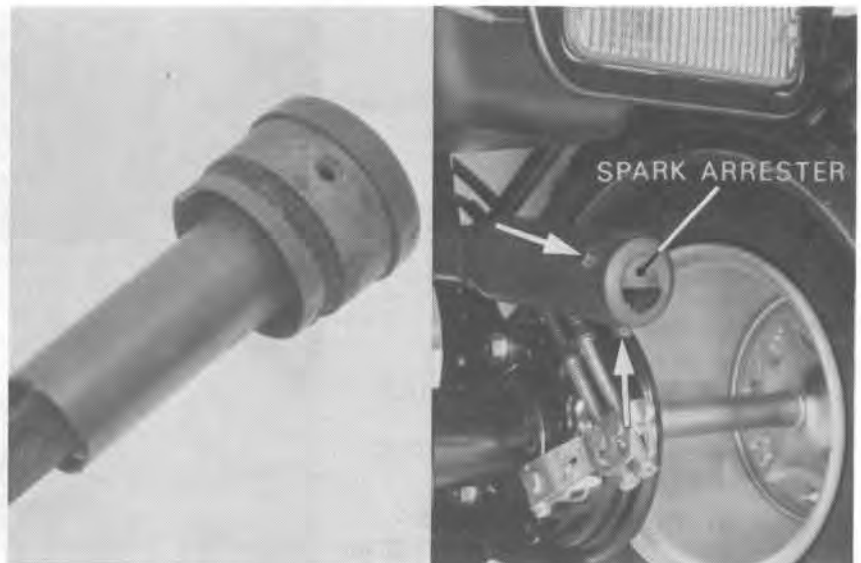



**INSPECTION/ADJUSTMENT**

**NUT, BOLTS, FASTENERS**

Tighten bolts, nuts and fasteners at regular intervals shown in the maintenance Schedule. (Page 1-8).

Check that all chassis nuts and bolts are tightened to their correct torque values (Page 1-4, 5). Check that all cotter pins and safety clips are in place.

**LIGHTING EQUIPMENT**

Apply the parking brake lever.  
Start the engine.

Check the headlight and taillight by operating the switch on the headlight case.

Switch position	Function
OFF	: Lights are OFF
LO	: Headlight low beam and taillight are ON
HI	: Headlight high beam and taillight are ON

Replace the bulb or switch if necessary.



**TIRES**

Check the tire for cuts, imbedded nails, or other sharp objects.

**NOTE**

Tire pressure should be checked when the tires are COLD.

Check the tire pressure.

**TIRE PRESSURES:**

Recommended pressure: 0.15 kg/cm<sup>2</sup> (2.2 psi)

Minimum pressure: 0.12 kg/cm<sup>2</sup> (1.7 psi)

**STANDARD TIRE CIRCUMFERENCE:**

1,963 mm (77.28 in)







## STEERING HEAD BEARINGS

### NOTE

Make sure the cables do not interfere with the rotation of the handlebar.

Raise the front wheel off the ground and make sure that the handlebar rotates freely.

If the handlebar moves unevenly, binds or has vertical movement, adjust the steering head bearing by turning the steering head adjusting nut with a pin spanner (Page 11-21).

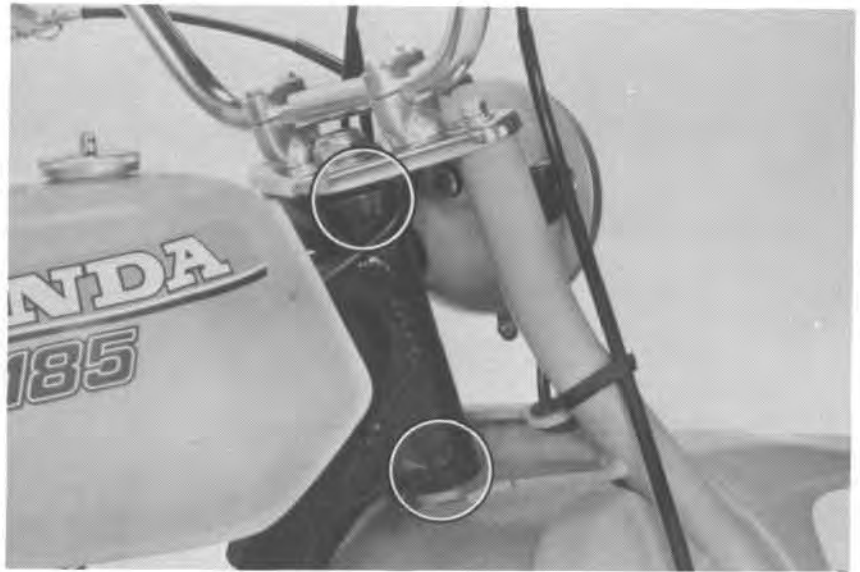

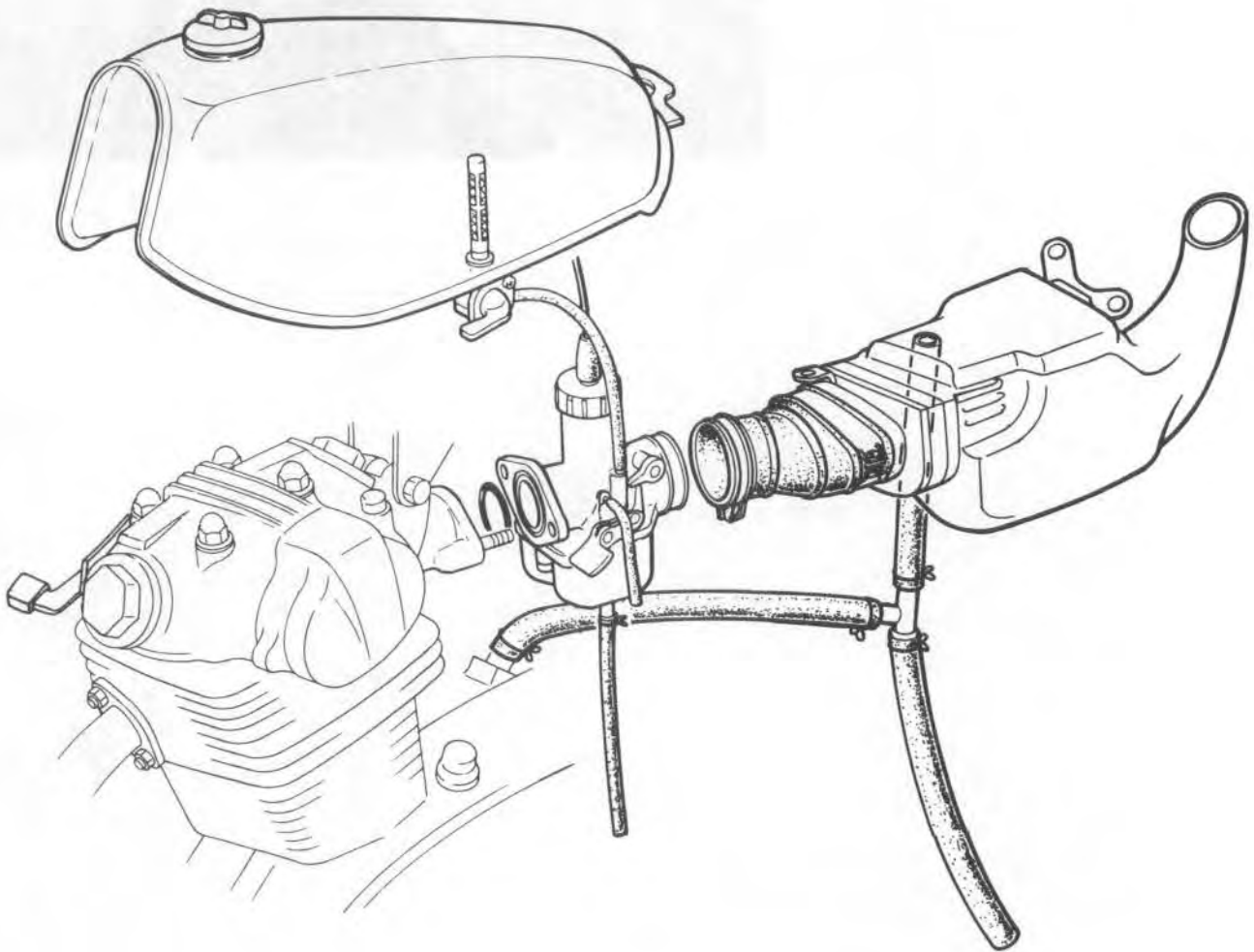



SERVICE INFORMATION	4-1
TROUBLESHOOTING	4-2
FUEL TANK	4-3
AIR CLEANER CASE	4-4
CRANKCASE BREATHER	4-5
CARBURETOR REMOVAL	4-6
THROTTLE VALVE DISASSEMBLY	4-7
FLOAT, FLOAT VALVE AND JETS	4-7
CARBURETOR ASSEMBLY	4-8
FLOAT LEVEL ADJUSTMENT	4-9
THROTTLE VALVE ASSEMBLY	4-9
CARBURETOR INSTALLATION	4-9
PILOT SCREW ADJUSTMENT	4-10
HIGH ALTITUDE ADJUSTMENT	4-10

## SERVICE INFORMATION

### GENERAL INSTRUCTIONS

- Use caution when working with gasoline. Always work in a well ventilated area away from sparks or flames.
- When disassembling fuel system parts, note the locations of the O-rings. Replace them during reassembly.

### SPECIFICATIONS

Fuel tank capacity                      8.8 lit (23 US gal, 1.9 Imp gal)  
 Fuel reserve capacity                1.6 lit (0.42 US gal, 0.35 Imp gal)

#### Carburetor

Identification mark	PD35A
Type	Piston valve
Venturi	22 mm (0.9 in)
Float level	12.5 mm (0.49 in)
Pilot screw opening	2 turns out
Idle speed	1,400 ± 100 rpm
Main jet	# 95
Throttle lever free play	5-10 mm (3/16-3/8 in)

### TOOL

Common  
 Float level gauge:                      07401-0010000



## **TROUBLESHOOTING**

### **Engine cranks but won't start**

1. No fuel in tank
2. No fuel to cylinder
3. Too much fuel getting to cylinder
4. No spark at plug (ignition malfunction)
5. Air cleaner clogged

### **Engine idles roughly, stalls, or runs poorly**

1. Idle speed incorrect
2. Ignition malfunction
3. Rich mixture
4. Lean mixture
5. Air cleaner dirty
6. Insulator leaks

#### **Lean mixture**

1. Carburetor fuel jet clogged
2. Fuel cap vent blocked
3. Fuel filter clogged
4. Fuel line kinked or restricted
5. Float valve faulty
6. Float level too low

#### **Rich mixture**

1. Carburetor choke stuck closed
2. Float valve faulty
3. Float level too high
4. Carburetor air jet clogged
5. Air cleaner dirty



### FUEL TANK

Remove the seat.  
Turn the fuel valve OFF, and disconnect the fuel tube.  
Remove the fuel tank.

**WARNING**

*Keep gasoline away from flames or sparks. Wipe up spilled gasoline at once.*

Check that fuel flows freely out of the fuel valve.  
If flow is restricted, clean the fuel strainer.  
Install the fuel tank.  
Connect the fuel tube.  
Install the seat.

**NOTE**

- After assembly, make sure there are no fuel leaks.
- Do not overtighten the fuel valve lock nut.

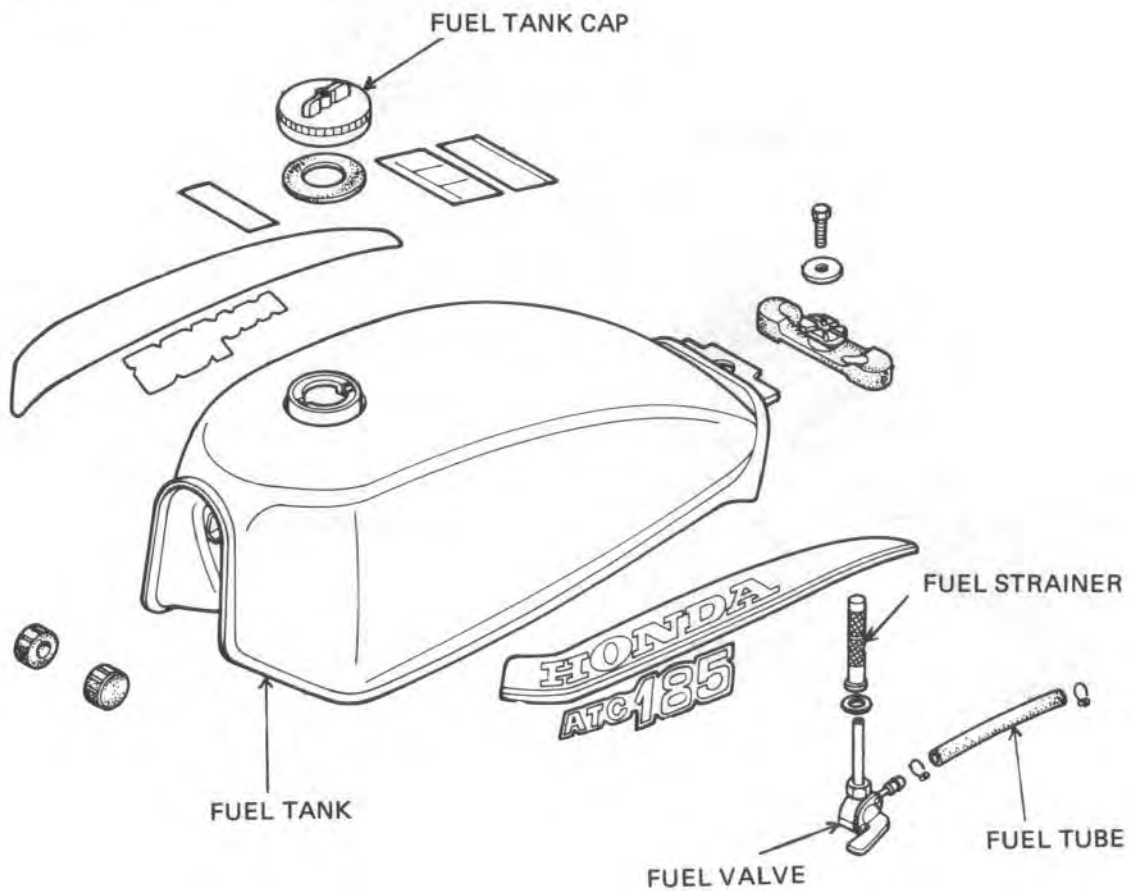



## AIR CLEANER CASE

Remove the seat and air cleaner case cover.  
Loosen the connecting tube band.  
Remove the bolts and air cleaner case.

Remove the element holder and air cleaner element.  
For air cleaner element service, see Page 3-3.

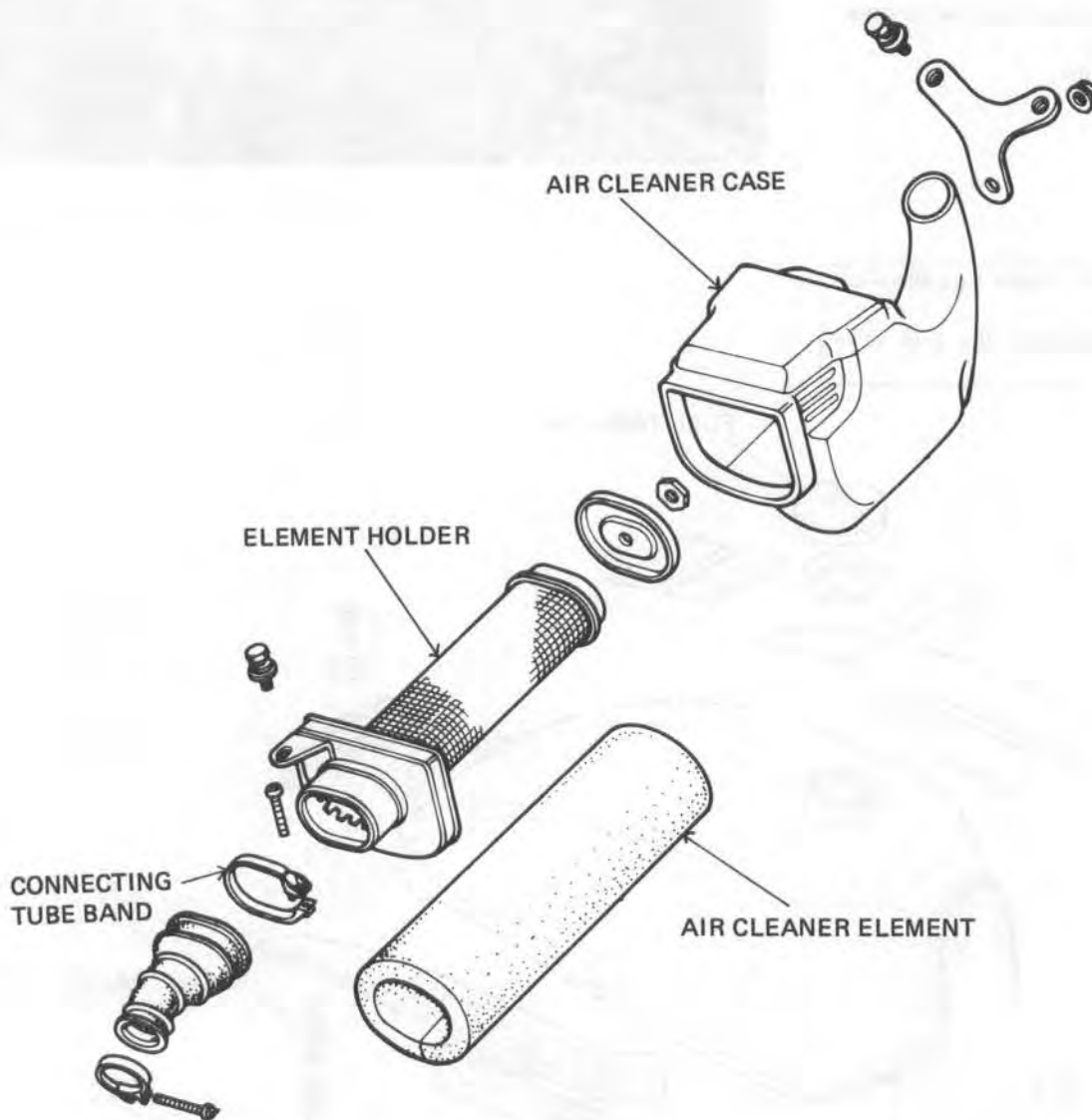



## CRANKCASE BREATHER

Route the crankcase breather tube as shown.

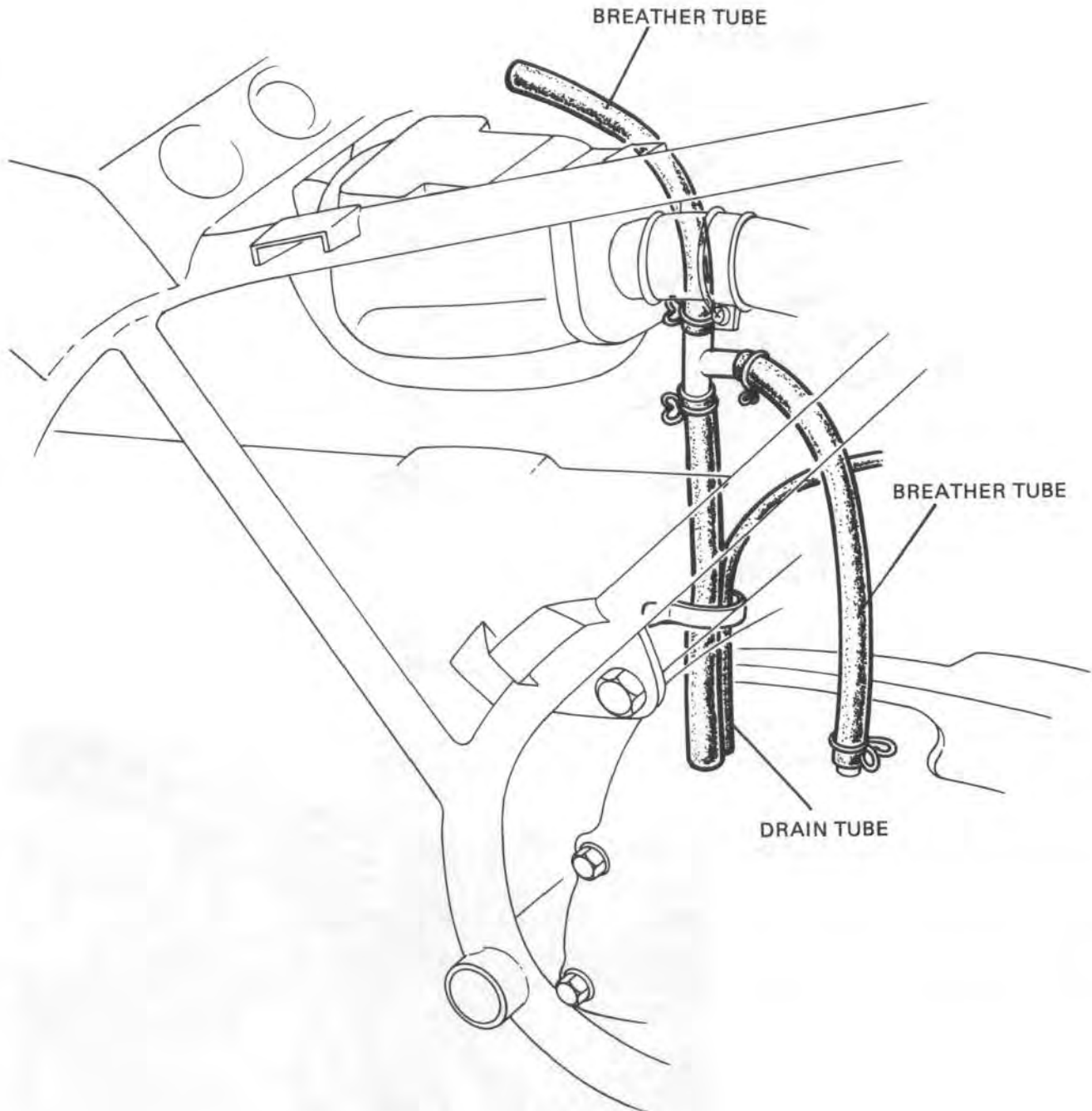



**CARBURETOR REMOVAL**

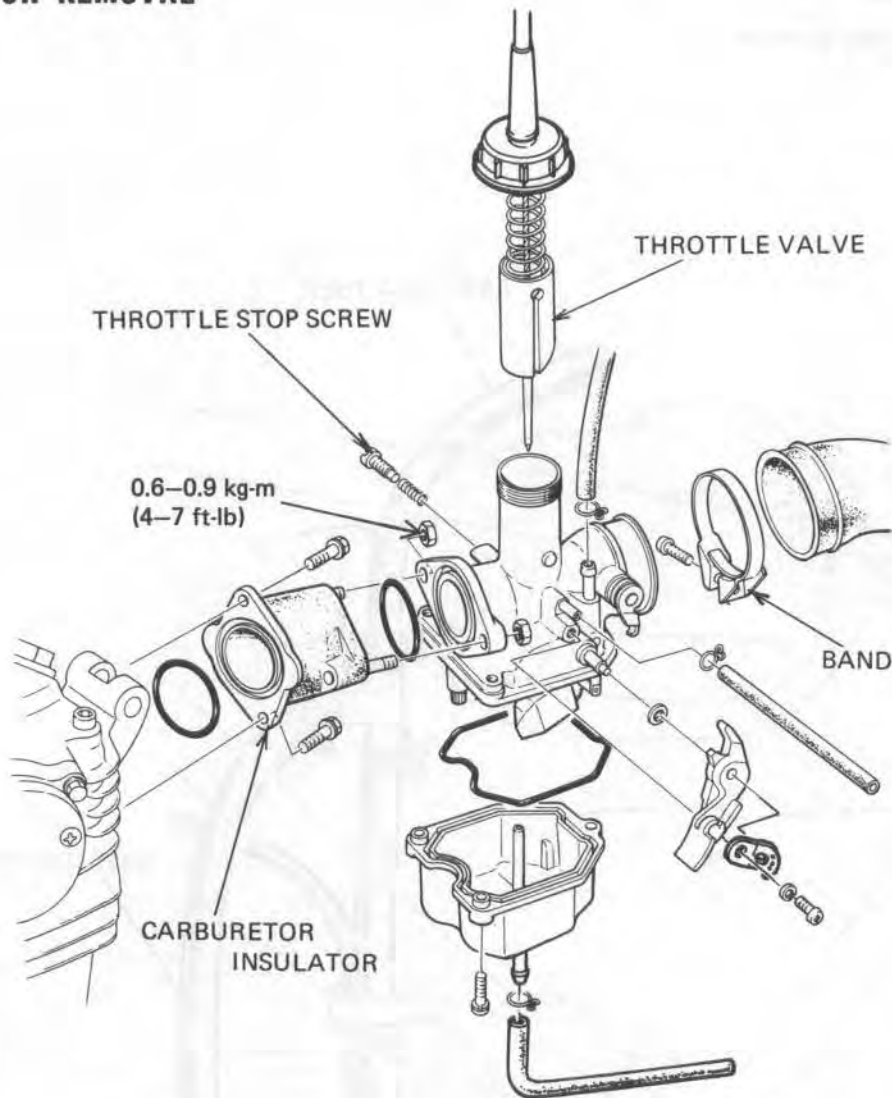

- Remove the seat.
- Turn the fuel valve OFF and disconnect the fuel line.
- Remove the fuel tank.
- Loosen the drain screw and drain the gasoline.
- Remove the right rear fender.
- Unscrew the carburetor top and pull the throttle valve out.
- Loosen the screw securing the carburetor band and remove the carburetor setting nuts.
- Remove the carburetor.







### THROTTLE VALVE DISASSEMBLY

Remove the throttle cable from the throttle valve while depressing the throttle valve spring.

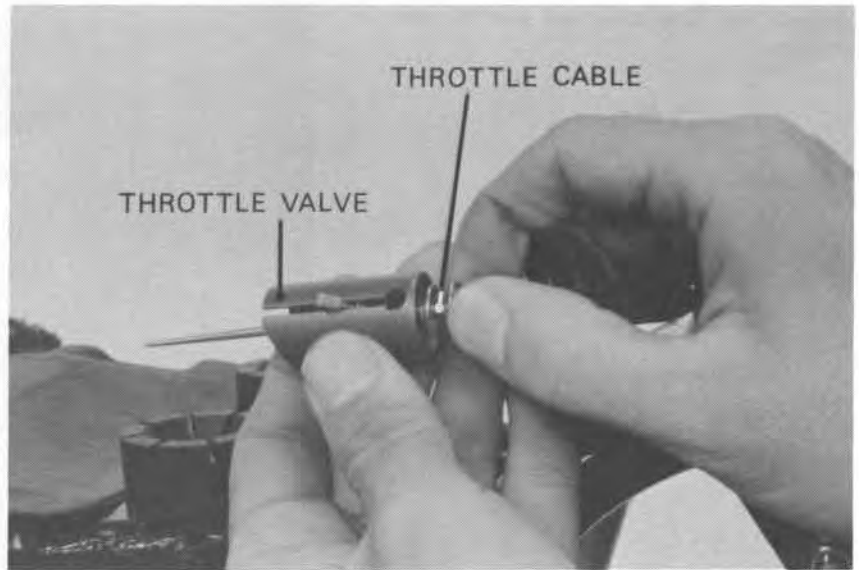

Remove the needle clip retainer.  
Remove the jet needle and needle clip.  
Inspect the throttle valve and jet needle surface for dirt, scratches or wear.

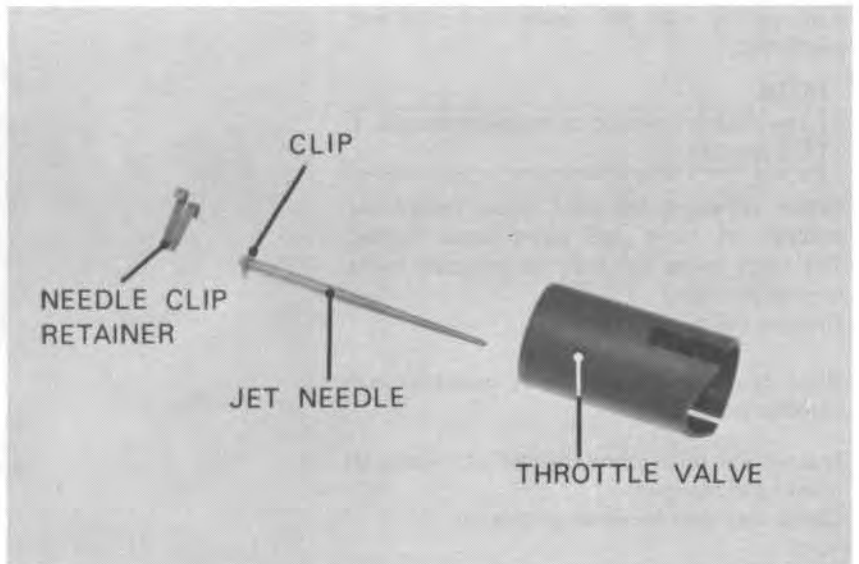

### FLOAT, FLOAT VALVE AND JETS

Remove the float chamber body.  
Remove the float arm pin with pliers.  
Remove the float and float valve.

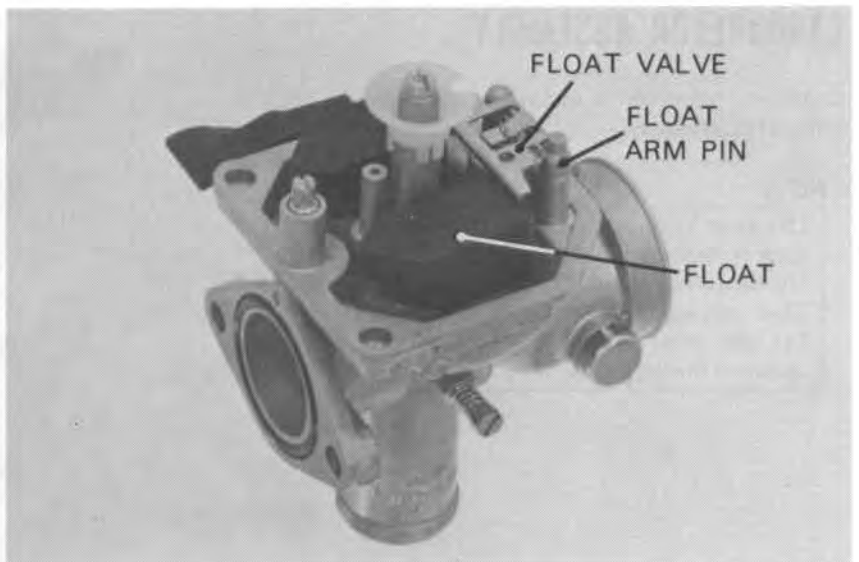



## FUEL SYSTEM

Inspect the float valve and seat for wear or damage.



Remove the main jet, needle jet holder and needle jet.

### NOTE

The slow jet cannot be removed since it is a press fit.

Before removing the pilot screw, record the number of turns the screw seats lightly. The pilot screw can then be returned to its original position.

Remove the pilot screw.

Blow open all jets and body openings with compressed air.

Inspect the pilot screw, needle jet, needle jet holder and main jet.

Check each part for wear or damage.

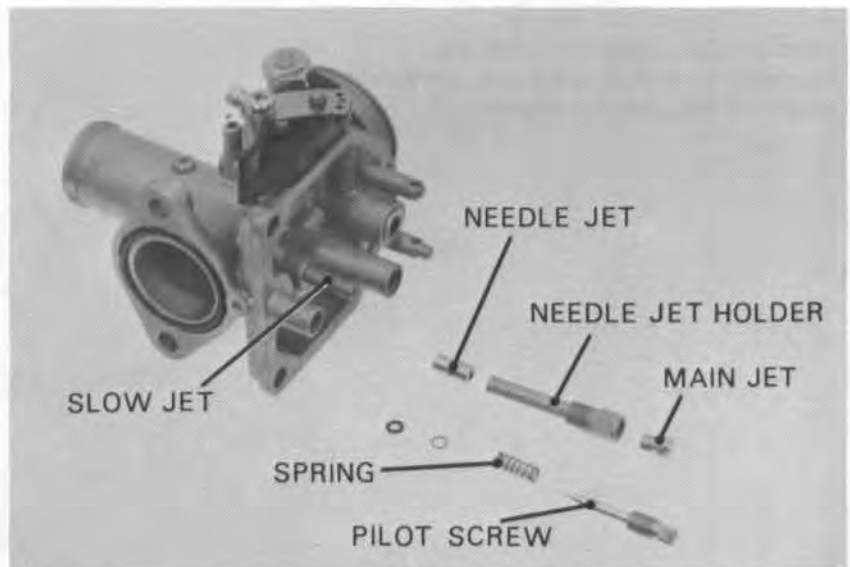

## CARBURETOR ASSEMBLY

Carburetor assembly is essentially the reverse order of disassembly.

### NOTE

Use new O-rings whenever the carburetor is reassembled.

Handle all jets and needles with care.

They can easily be scored or scratched.

Set the pilot screw to the position recorded during disassembly.

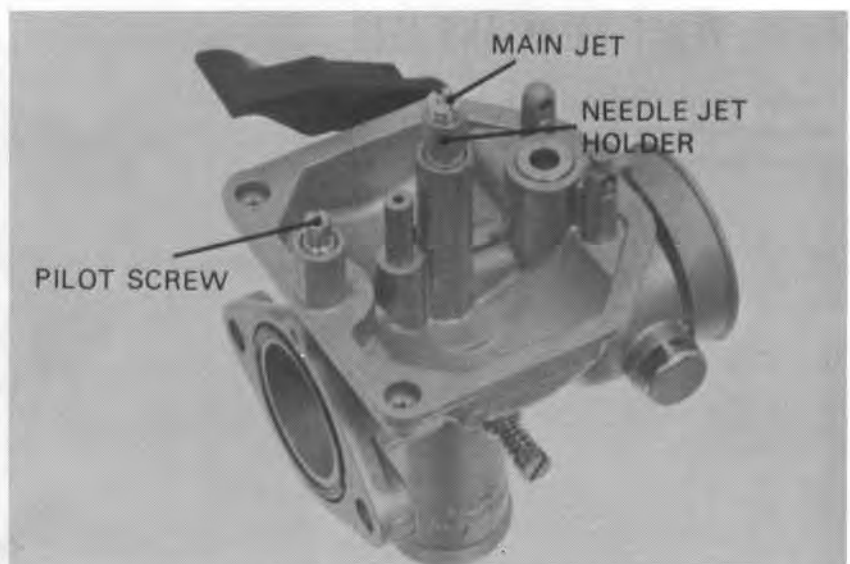



## FLOAT LEVEL ADJUSTMENT

Measure the float level with a float level gauge as shown.

**FLOAT LEVEL: 12.5 mm (0.49 in)**

To adjust the float level, bend the float arm carefully until the float tip just contacts the float valve.

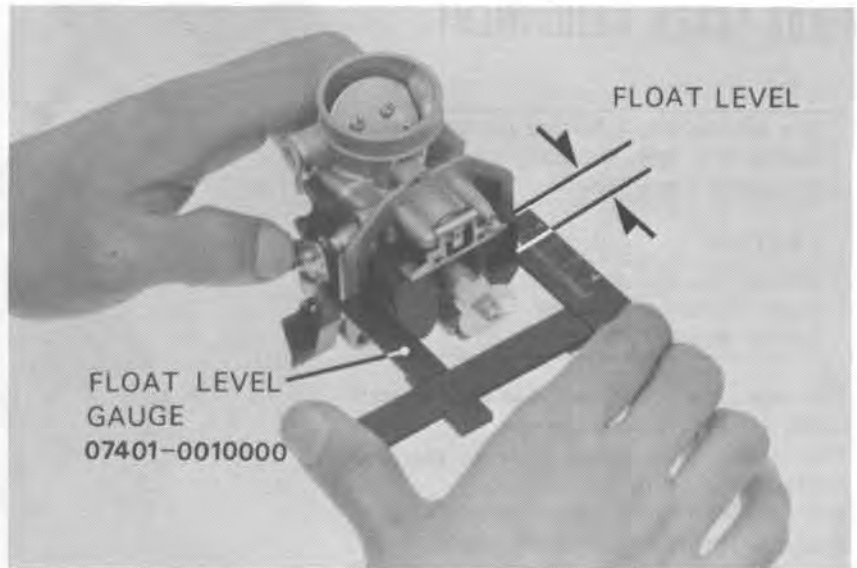

## THROTTLE VALVE ASSEMBLY

Install the needle clip on the jet needle.

**STANDARD SETTING: Second groove**

Install the jet needle into the throttle valve and secure it with the needle clip retainer.

Install the throttle cable and spring.  
Install the throttle valve.

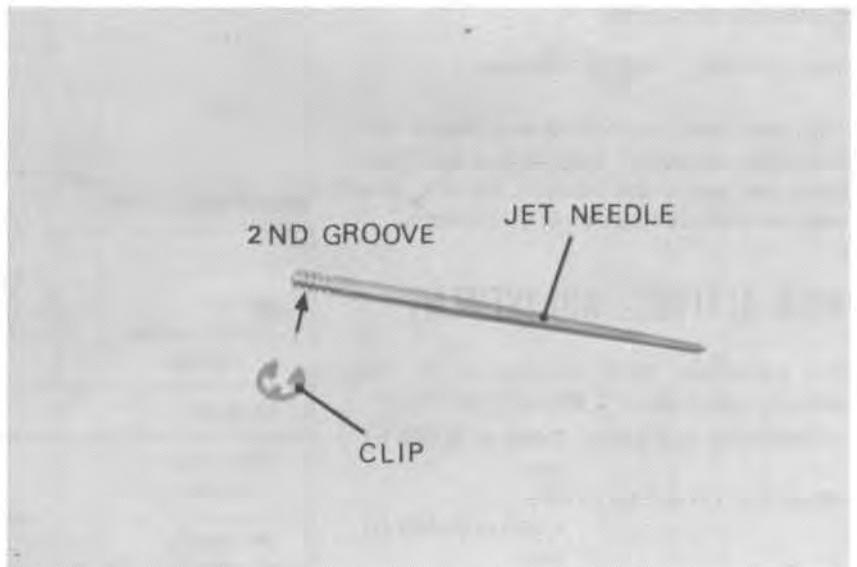

## CARBURETOR INSTALLATION

Carburetor installation is essentially the reverse of removal.

### NOTE

- When installing the throttle valve, align the throttle valve groove with the throttle stop screw.
- After installing the carburetor, perform the following adjustments:  
Throttle lever free play (Page 3-7).  
Carburetor pilot screw adjustment (Page 4-10) if the carburetor was overhauled.

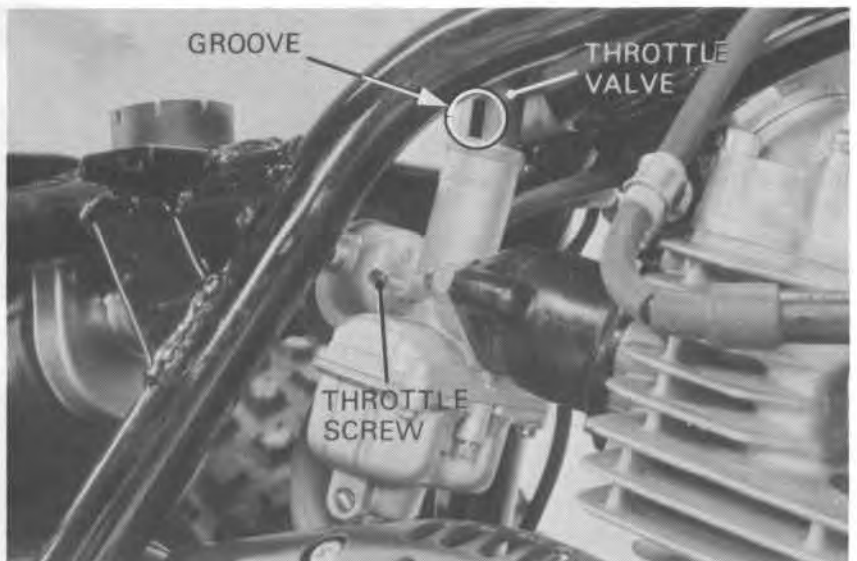



**FUEL SYSTEM**

**PILOT SCREW ADJUSTMENT**

**NOTE**

The pilot screw is factory pre-set. Adjustment is not necessary unless the carburetor is overhauled.

**CAUTION**

Damage to the pilot screw seat will occur if the pilot screw is tightened against the seat.

Turn the pilot screw clockwise until it seats lightly and back it out 2 turns.

This is an initial setting prior to the final pilot screw adjustment.

Warm the engine up to operating temperature. Stop the engine and connect a tachometer. Start the engine and adjust the idle speed with the throttle stop screw.

**IDLE SPEED: 1400 ± 100 rpm**

Turn the pilot screw clockwise slowly until the engine stops, and then back it out 1 turn. Start the engine and readjust the idle speed with the throttle stop screw, if necessary.

**HIGH ALTITUDE ADJUSTMENT**

The carburetor must be adjusted for high altitude riding (above 2,500 m/6,500 ft).

**STANDARD SETTING: 2,000 m (6,500 ft) max.**

**HIGH ALTITUDE SETTING: 1,500 m (5,000 ft) min.**

High altitude carburetor adjustment is performed as follows:

Remove and disassemble the carburetor (Page 4-5 and 4-6).

Replace the standard main jet with the high altitude type (# 82).

Assemble the carburetor.  
Install the carburetor.



**SPECIFICATIONS**

	Standard (2,000 m/6,500 ft max.)	High altitude (1,500 m/5,000 ft min.)
Identification number	PD35A	←
Main jet	# 95	# 82
Pilot screw opening	Factory preset	1/4 turn clockwise
Jet needle	Second groove	First groove





Remove the throttle valve.  
Remove the jet needle (Page 4-7).

Change the jet needle clip position from the 2nd groove (standard) to the 1st groove.

Install the jet needle.  
Install the throttle valve.

Turn the pilot screw clockwise 1/4 turn.  
Start the engine and adjust the idle speed at high altitude to ensure proper high altitude operation.

**CAUTION:**

*Sustained operation below 1,500 m (5,000 ft) with the high altitude settings may cause engine overheating and engine damage. Install the #95 main jet, return the jet needle clip position to the 2nd groove and pilot screw to the factory preset position when riding below 1,500 m (5,000 ft).*



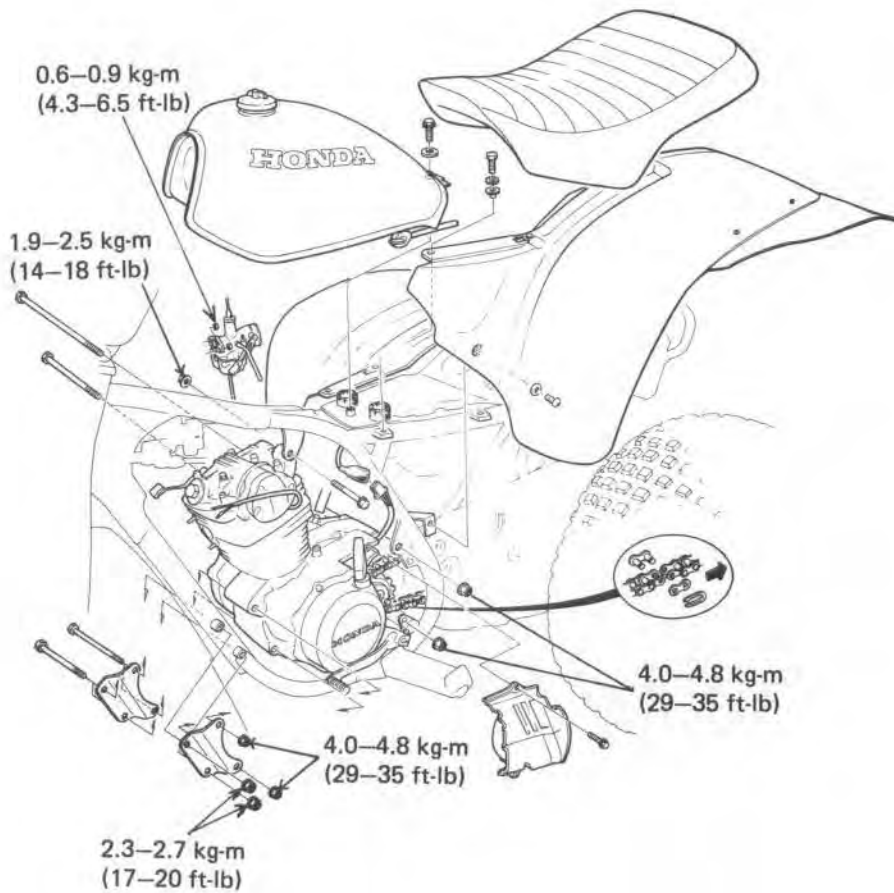
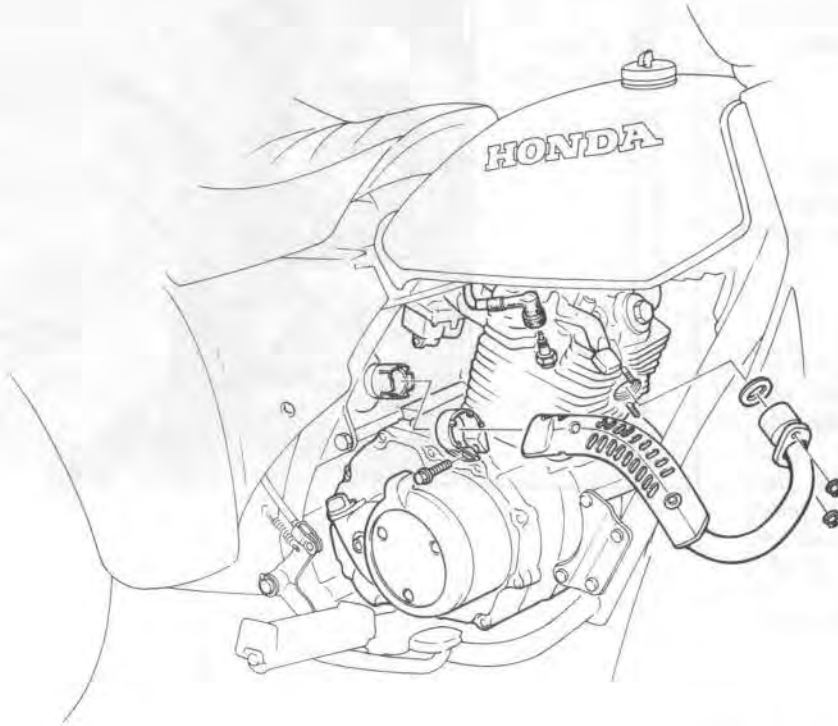



SERVICE INFORMATION	5-1
ENGINE REMOVAL	5-2
ENGINE INSTALLATION	5-5

## SERVICE INFORMATION

### GENERAL INSTRUCTIONS

This section covers removal and installation of the engine.

Operations requiring engine removal:

- Cylinder head Section 6
- Cylinder and piston Section 7
- Crankshaft, transmission Section 10

Upon reassembly, make sure that no exhaust gas leaks past the exhaust pipe connection.

### SPECIFICATIONS

Engine dry weight	30.2 kg (66.5 lb)
Engine oil capacity	1.35 lit (1.43 US qt, 1.19 Imp qt) after disassembly 0.95 lit (1.00 US qt, 0.84 Imp qt) after draining

### TORQUE VALUES

Upper engine hanger nut	1.9-2.5 kg-m (14-18 ft-lb)
Front engine hanger 8 mm nut	2.3-2.7 kg-m (17-20 ft-lb)
10 mm nut	4.0-4.8 kg-m (29-35 ft-lb)
Rear engine hanger nut	4.0-4.8 kg-m (29-35 ft-lb)
Carburetor mounting nut	0.6-0.9 kg-m (4-7 ft-lb)
Rear axle bearing holder bolt	5.0-7.0 kg-m (36-51 ft-lb)



## ENGINE REMOVAL

Drain oil from the engine.  
Remove the seat.

Turn the fuel valve OFF and disconnect  
the fuel tube.  
Remove the fuel tank.



Disconnect the spark plug cap.  
Remove the exhaust pipe.

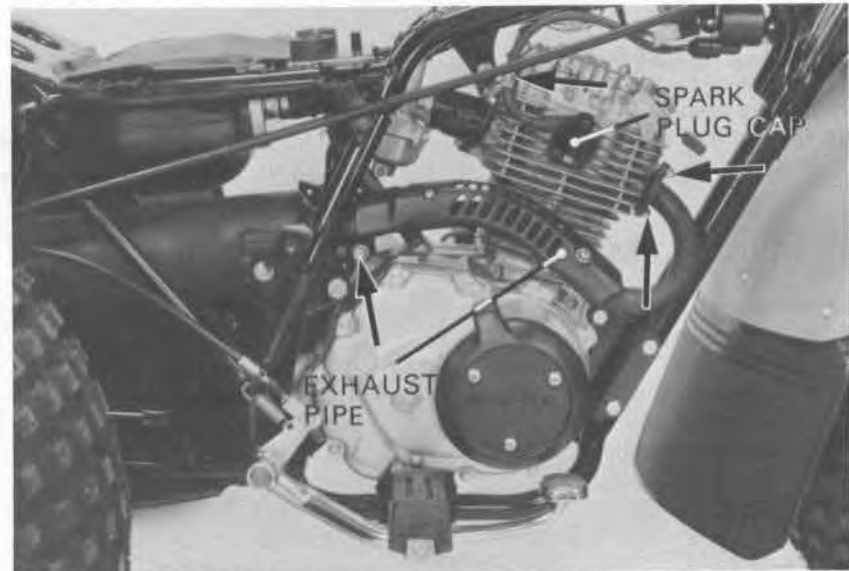

Disconnect the crankcase breather tube.  
Disconnect the A. C. generator coupler and  
pulser wires.

Remove the carburetor (Page 4-6).

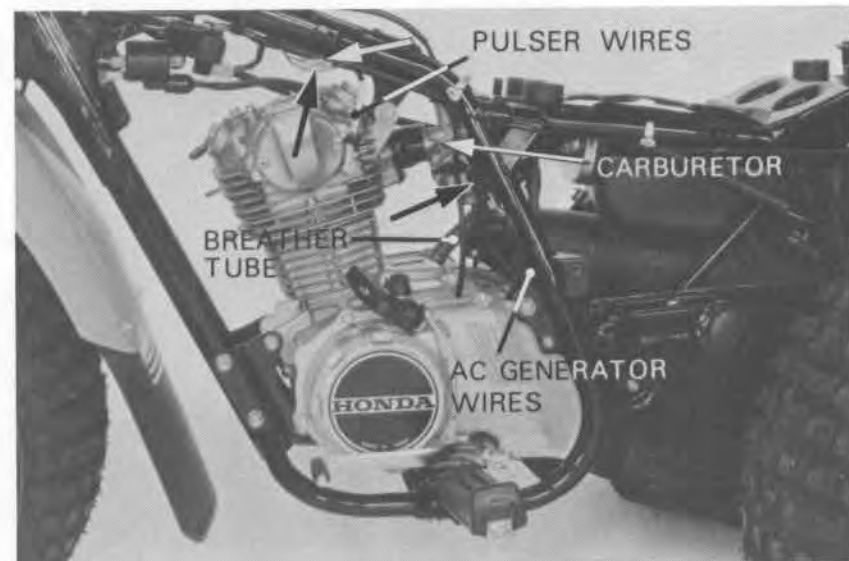





Remove the gearshift pedal.  
Remove the drive sprocket cover.

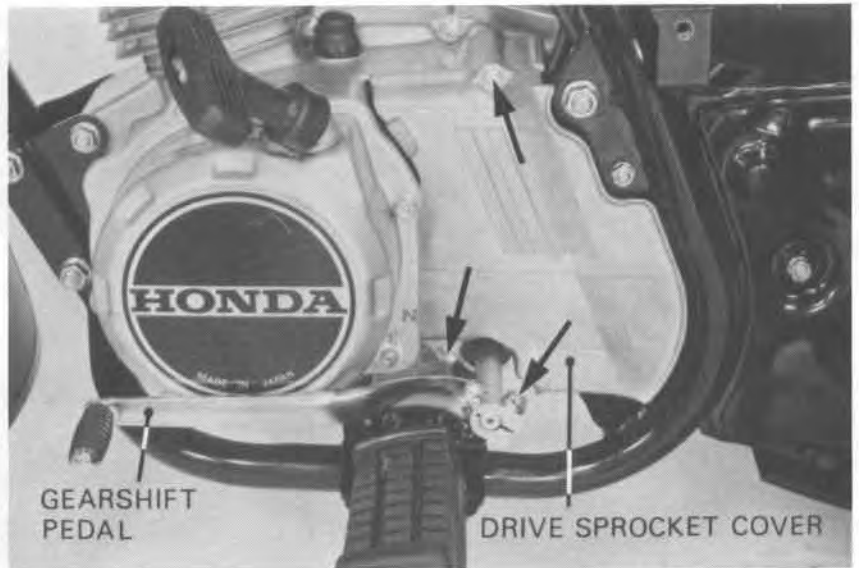

Loosen the rear wheel bearing holder attaching bolt and drive chain adjusting nut.

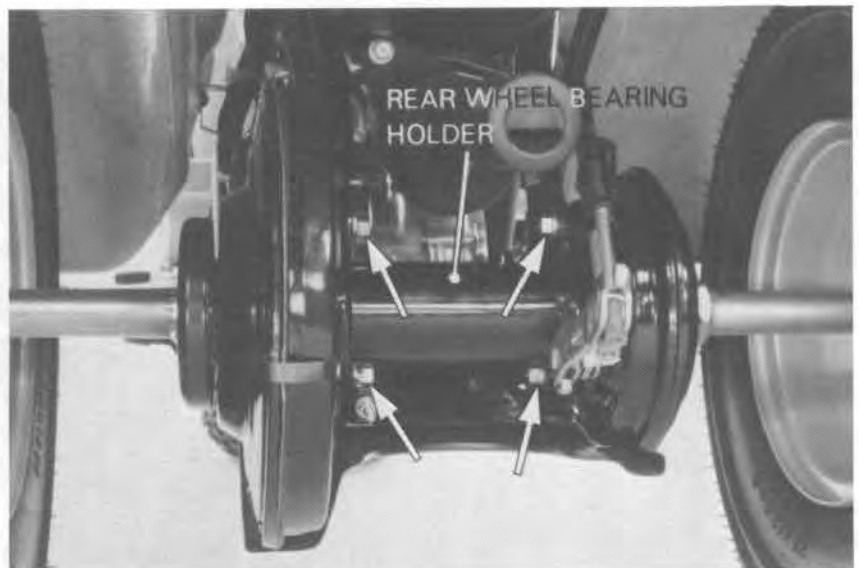

Disconnect the drive chain by removing the chain clip and master link.

Hold the drive chain with a piece of wire to prevent it from falling into the drive chain case.

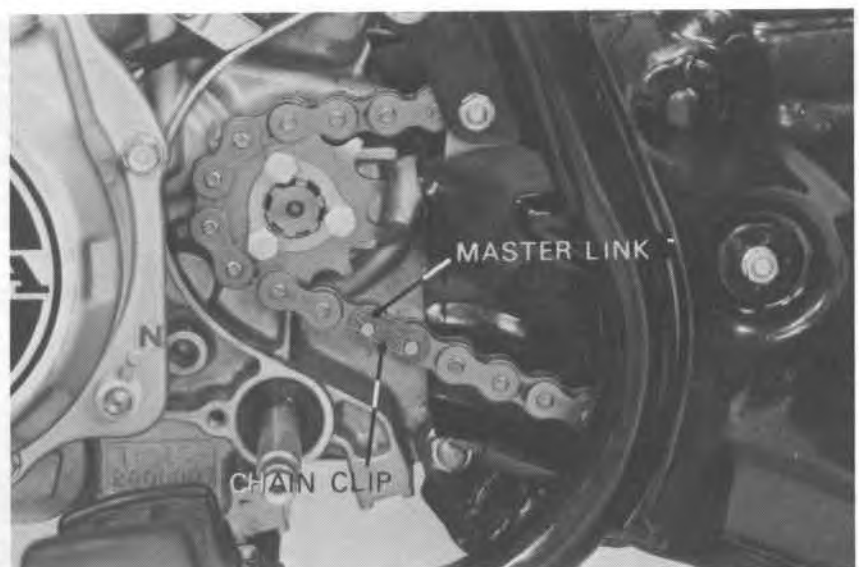



Remove the upper engine hanger bolt.



Remove the front engine hanger bolt and plates.

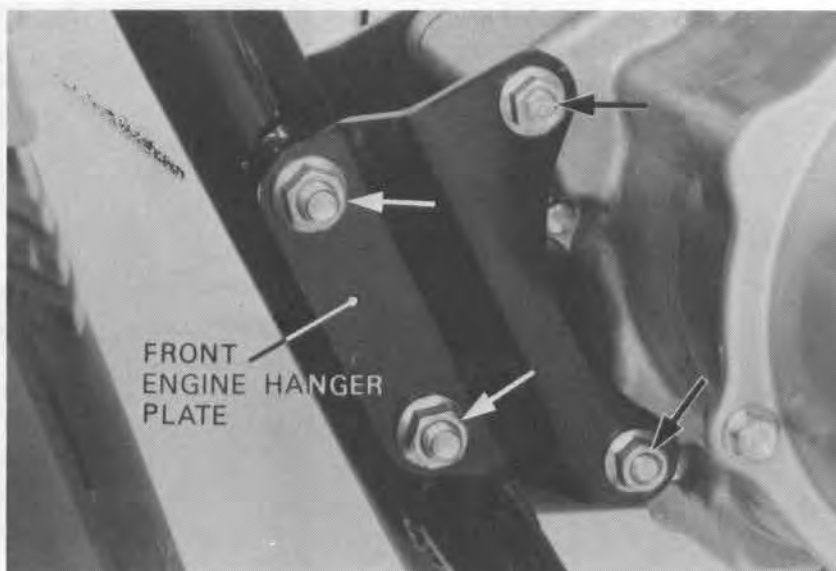

Remove the rear engine hanger bolts.  
Remove the engine from the left side of the frame.





**ENGINE INSTALLATION**

Install the engine in the reverse order of removal.

**NOTE**

- Use the correct bolts in their proper positions.
- Tighten the engine hanger bolts to the specified torque values after they are installed loosely.

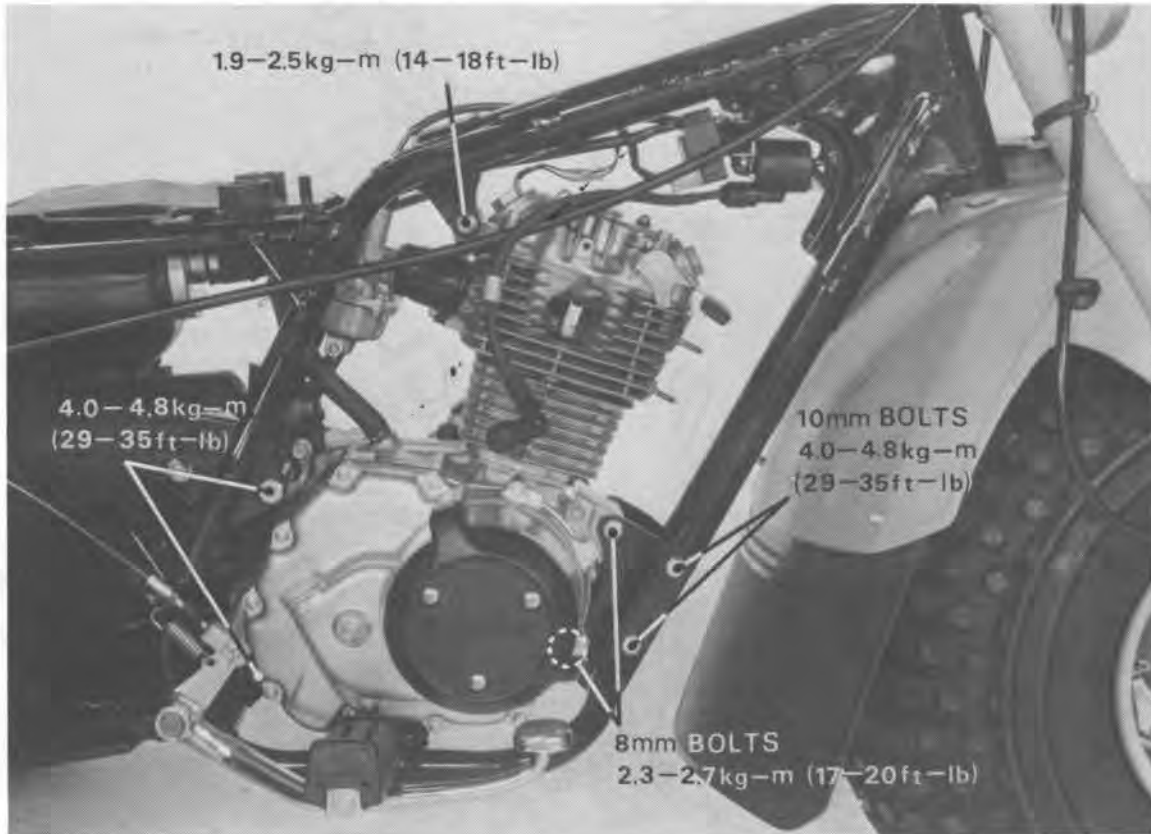
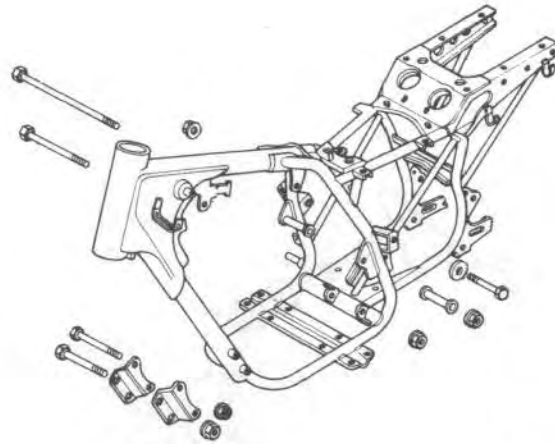

**NOTE**

- After installing the engine, perform the following inspections and adjustments:
- Engine oil level (Page 2–2)
  - Throttle lever free play (Page 3–7)
  - Drive chain slack (Page 3–9)
  - Check that exhaust gas is not leaking past the exhaust pipe connection
  - Check the electrical equipment performance.

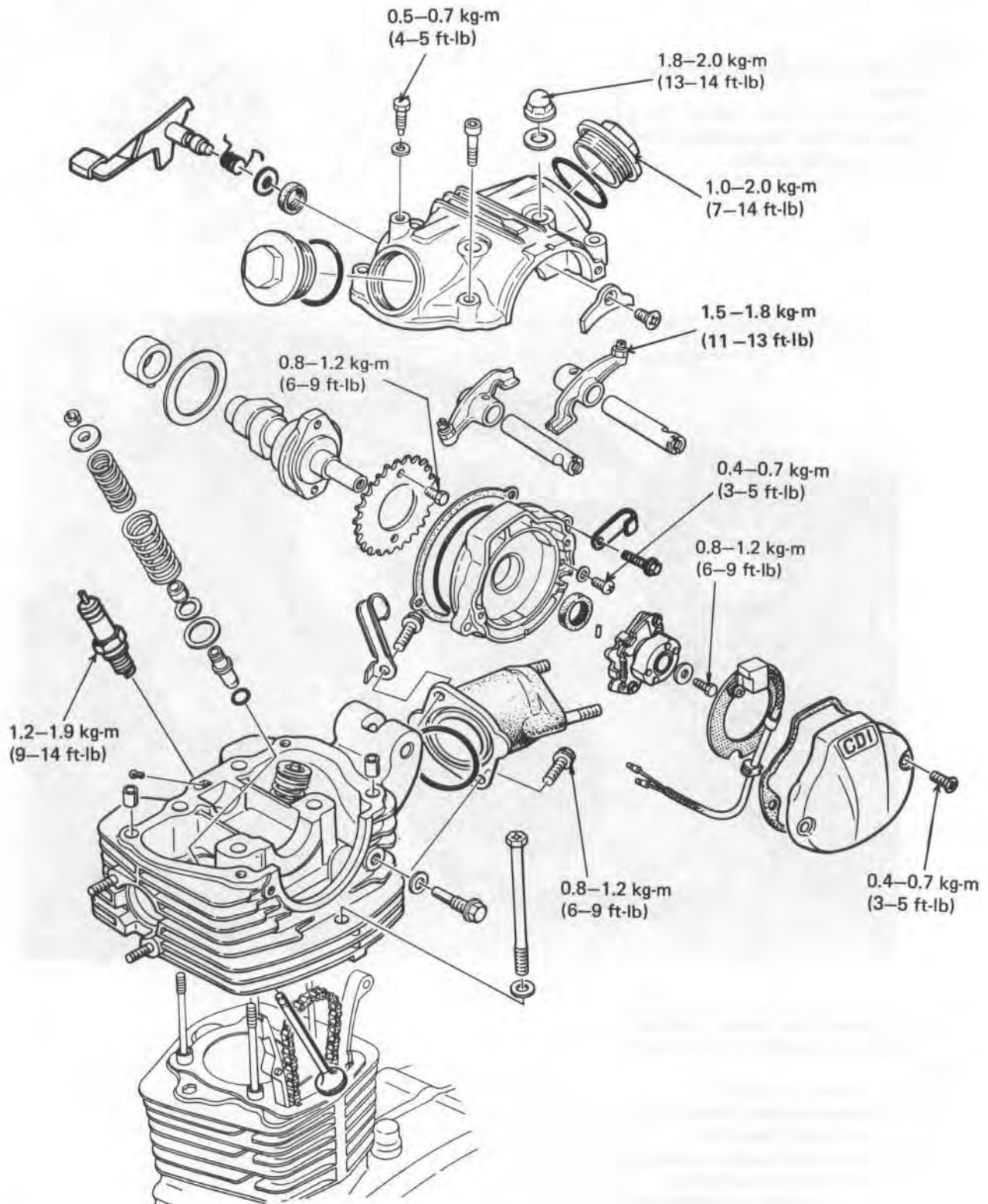



SERVICE INFORMATION	6-1	CYLINDER HEAD DISASSEMBLY	6-8
TROUBLESHOOTING	6-2	VALVE SEAT INSPECTION/REFACING	6-11
CAMSHAFT REMOVAL	6-3	CYLINDER HEAD ASSEMBLY	6-13
CYLINDER HEAD COVER REMOVAL	6-5	CYLINDER HEAD INSTALLATION	6-14
CYLINDER HEAD REMOVAL	6-7	CAMSHAFT INSTALLATION	6-17

## SERVICE INFORMATION

### GENERAL INSTRUCTIONS

- This Section covers cylinder head, valves, camshaft and rocker arms maintenance.
- The engine must be removed from the frame to service the cylinder head and valves.
- (To remove the cylinder head cover and the rocker arm alone, the engine removal is not required)
- Camshaft lubrication oil is fed to the cylinder head through an oil control orifice in the engine case. Be sure this orifice is not clogged and that the O-rings and dowel pins are in place before installing the cylinder head.
- Before assembly, apply molybdenum disulfide grease to the camshaft bearings to provide initial lubrication.
- Pour clean engine oil into the oil pockets in the cylinder head during assembly to lubricate the cam.

### TOOLS

Special	
Valve Guide Reamer	07984-0980000
Common	
Valve Guide Driver B	07742-0020200 or 07942-3290200
Valve Guide Remover 5.5 mm	07742-0010100 or 07942-3290100
Valve Spring Compressor	07757-0010000 or 07957-3290001

### TORQUE VALUES

Cylinder head	1.8-2.0 kg-m (13-14 ft-lb)
Cam sprocket	0.8-1.2 kg-m (6-9 ft-lb)
Carburetor insulator	0.8-1.2 kg-m (6-9 ft-lb)
Pulser rotor	0.8-1.2 kg-m (6-9 ft-lb)
Decompressor pivot bolt	0.5-0.7 kg-m (4-5 ft-lb)
Valve adjuster cover	1.0-2.0 kg-m (7-14 ft-lb)
Spark plug	1.2-1.9 kg-m (9-14 ft-lb)
Pulser cover screw	0.4-0.7 kg-m (3-5 ft-lb)
Pulser generator screw	0.4-0.7 kg-m (3-5 ft-lb)
Valve adjusting screw lock nut	1.5-1.8 kg-m (10-13 ft-lb)

**SPECIFICATIONS**

ITEM			STANDARD	SERVICE LIMIT
Cylinder compression			11 ± 1 kg/cm <sup>2</sup> (156 ± 14 psi)	_____
Camshaft	Cam lift	IN	31.379 mm (1.2354 in)	31.199 mm (1.2283 in)
		EX	30.978 mm (1.2196 in)	30.798 mm (1.2125 in)
	Journal OD	R	19.967–19.980 mm (0.7861–0.7866 in)	19.90 mm (0.784 in)
		L	33.957–33.970 mm (1.3370–1.3376 in)	33.90 mm (1.335 in)
Cylinder head	Bearing ID	L	33.980–34.075 mm (1.3378–1.3415 in)	34.05 mm (1.341 in)
	Warpage		_____	0.10 mm (0.004 in)
Camshaft bushing		ID	20.005–20.026 mm (0.7876–0.7884 in)	20.05 mm (0.789 in)
Rocker arm		ID	12.000–12.018 mm (0.4724–0.4730 in)	12.05 mm (0.474 in)
Rocker arm shaft		OD	11.977–11.995 mm (0.4715–0.4722 in)	11.93 mm (0.470 in)
Rocker arm-to-shaft clearance			0.005–0.041 mm (0.0002–0.0016 in)	0.08 mm (0.003 in)
Valve spring	Free length	Inner	39.4 mm (1.55 in)	35.5 mm (1.40 in)
		Outer	45.5 mm (1.79 in)	41.0 mm (1.61 in)
	Preload	Inner	83.0 ± 0.6 kg/33.7 mm (18.3 ± 1.3 lb/1.33 in)	_____
		Outer	21.0 ± 1.5 kg/38.4 mm (46.3 ± 3.3 lb/1.51 in)	_____
Valve, valve guide	Stem OD	IN	5.450–5.465 mm (0.2146–0.2152 in)	5.42 mm (0.213 in)
		EX	5.430–5.445 mm (0.2138–0.2144 in)	5.40 mm (0.213 in)
	Guide ID	IN	5.475–5.485 mm (0.2156–0.2159 in)	5.50 mm (0.217 in)
		EX	5.475–5.485 mm (0.2156–0.2159 in)	5.50 mm (0.217 in)
	Stem-to-guide clearance	IN	0.010–0.035 mm (0.0004–0.0014 in)	0.12 mm (0.005 in)
		EX	0.030–0.055 mm (0.0012–0.0022 in)	0.14 mm (0.006 in)
Valve face width			1.7 mm (0.07 in)	2.0 mm (0.08 in)
Valve seat width			1.2 mm (0.05 in)	1.5 mm (0.06 in)

**TROUBLESHOOTING**

Engine top-end problems usually affect engine performance. These problems can be diagnosed by a compression test, or by tracing engine noises to the top-end with a sounding rod or stethoscope.

**Low compression**

1. Valve
  - Incorrect valve adjustment
  - Burned or bent valve
  - Incorrect valve timing
  - Weak valve spring
2. Cylinder head
  - Leaking or damaged head gasket
  - Warped or cracked cylinder head
3. Cylinder and piston (Section 7)
4. Faulty decompressor lever

**High compression**

1. Excessive carbon build-up on piston crown or on combustion chamber

**Excessive noise**

1. Incorrect valve adjustment
2. Sticking valve or broken valve spring
3. Damaged or worn rocker arm or camshaft
4. Worn or damaged cam chain
5. Worn or damaged cam chain tensioner
6. Worn cam sprocket teeth

**Poor idling**

1. Compression too low
2. Faulty decompressor lever

**Hard starting**

1. Faulty decompressor lever



## CAMSHAFT REMOVAL

Remove the pulser cover.

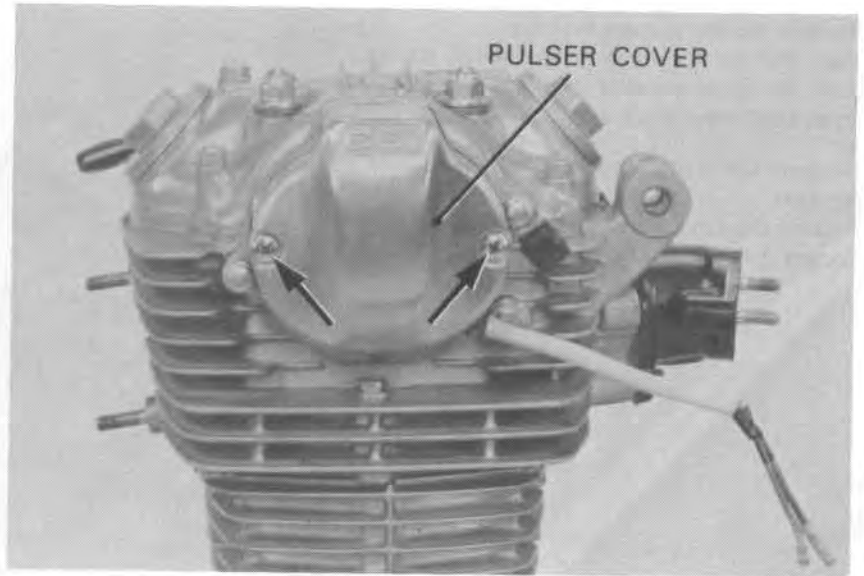

Remove the pulser generator screws, and  
remove the pulser generator.  
Remove the pulser rotor.

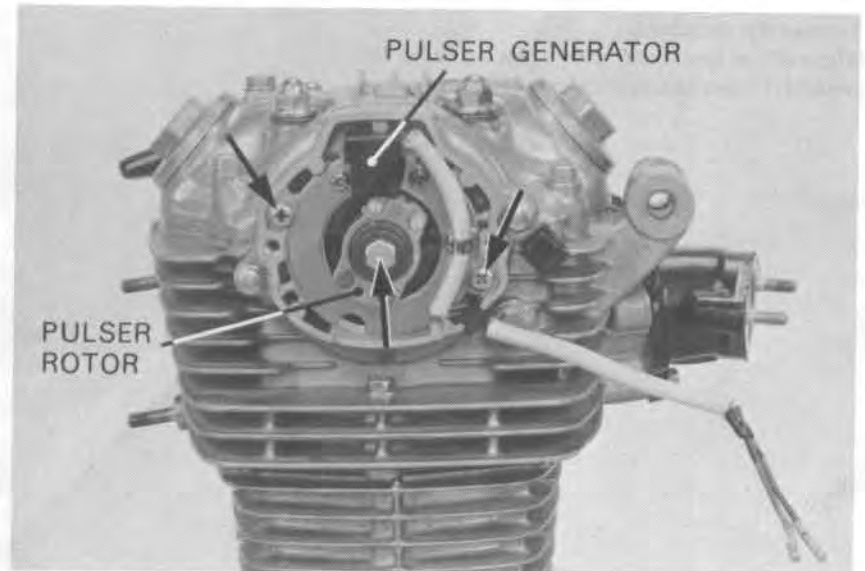

Remove the dowel pin.  
Remove the pulser base.

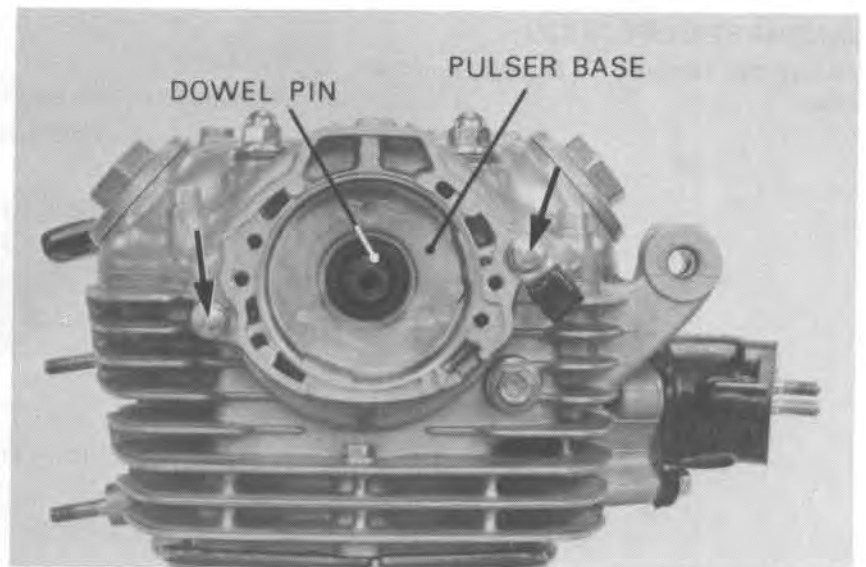



## CYLINDER HEAD/VALVES

Remove the timing mark hole cap.  
Turn the crankshaft with the recoil starter until the cam sprocket "O" mark and cylinder head index mark align.

Remove the cam sprocket bolts and cam sprocket.  
Remove the valve adjuster covers.  
Loosen the valve adjusters.

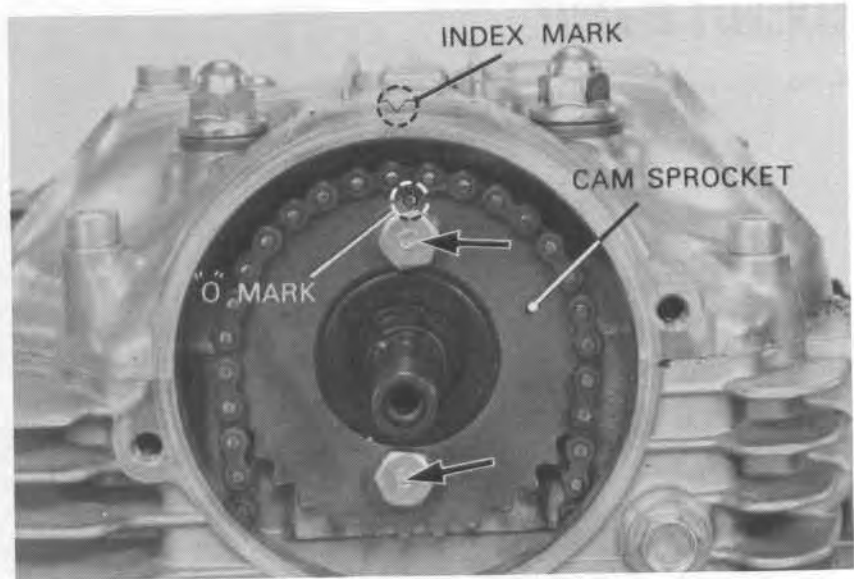

Remove the camshaft.  
Suspend the cam chain with a piece of wire to prevent it from falling into the crankcase.

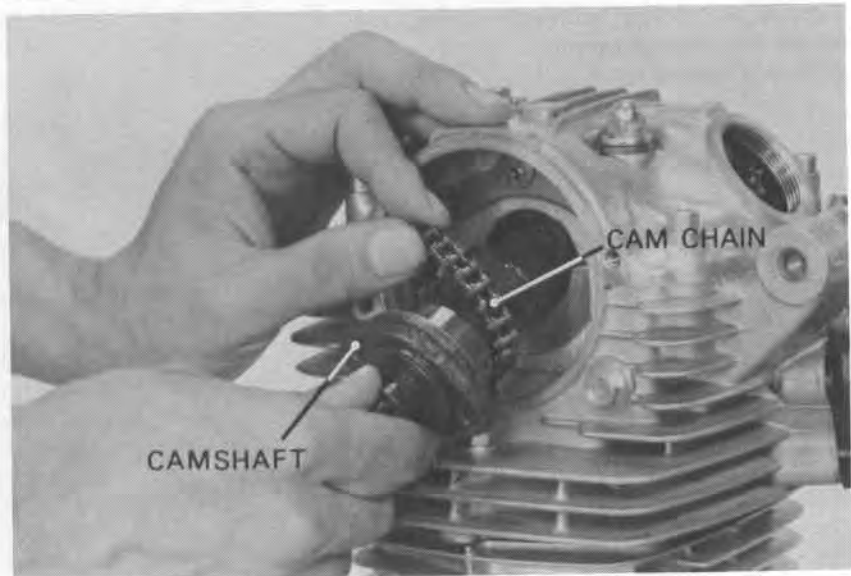

### CAMSHAFT INSPECTION

Measure the camshaft O. D, with a micrometer.

STANDARD:

R: 19.967-19.980mm(0.7861-0.7866in)

L: 33.957-33.970mm(1.3369-1.3374in)



SERVICE LIMITS:

RIGHT: 19.90mm(0.784in)

LEFT: 33.90mm(1.335in)





Using a micrometer, measure each cam lobe height and inspect it for wear or damage.

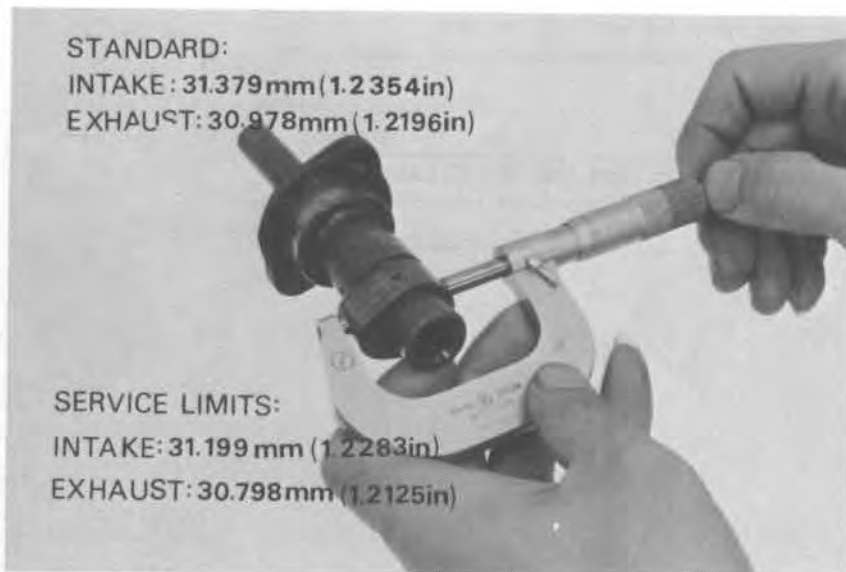

### CYLINDER HEAD COVER REMOVAL

Remove the engine from the frame (Page 5-2).  
Remove the 6 mm socket bolts and 8 mm cap nuts.

Remove the cylinder head cover.  
Remove the camshaft bushing.

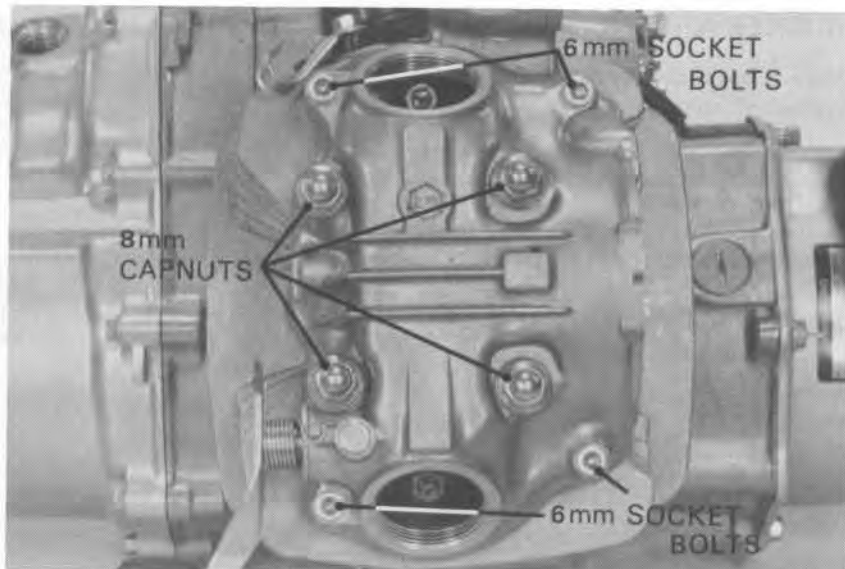

Remove the decompressor lever and spring by removing the decompressor lever guide bolt.

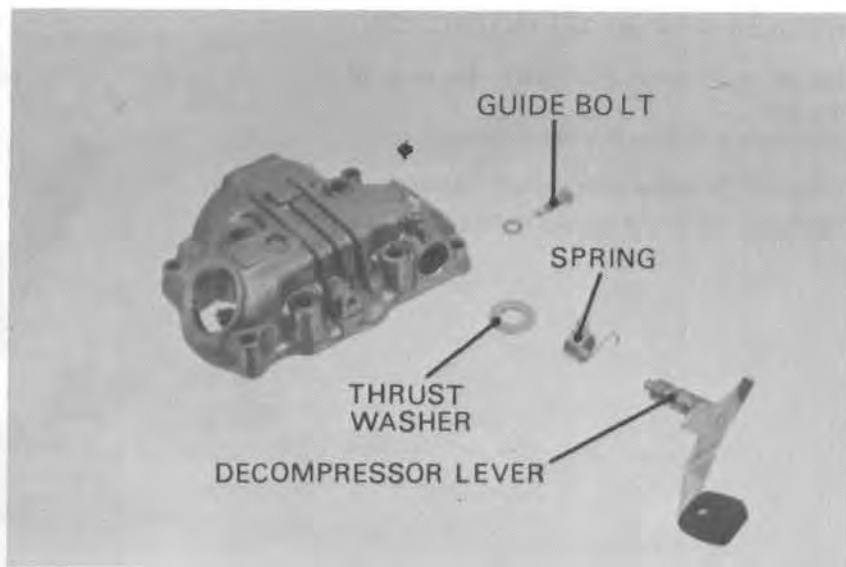



## CYLINDER HEAD/VALVES

Remove the rocker arm shaft set plate.  
Remove the rocker arm shafts, and rocker arms.

### NOTE

Screw a 6 mm bolt into the threaded end of the rocker arm shaft to remove it.

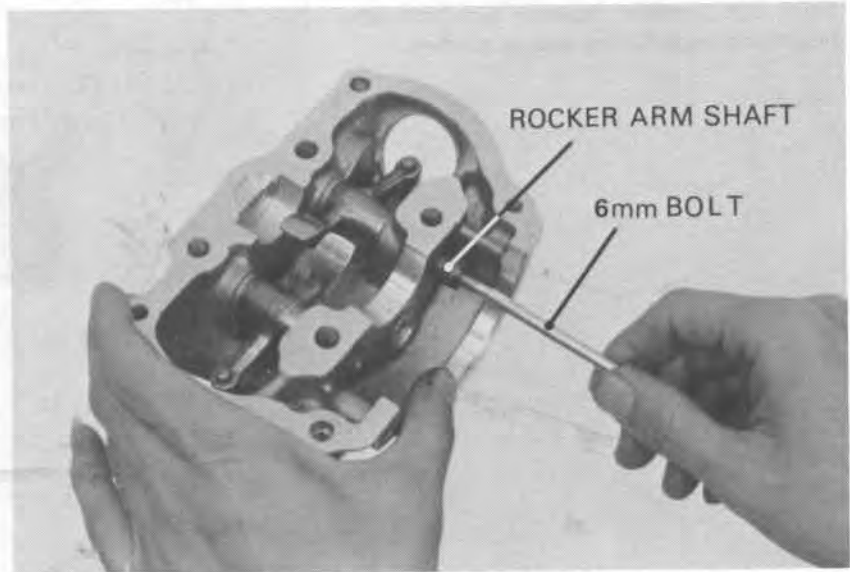

## ROCKER ARM INSPECTION

Inspect the rocker arms for damage, wear or clogged oil holes.

### NOTE

If any rocker arms require servicing or replacement, inspect the cam lobes for scoring, chipping or flat spots.

Measure the I.D. of each rocker arm.



## ROCKER ARM SHAFT INSPECTION

Inspect the rocker arm shafts for wear or damage.

Measure the O.D. with a micrometer.

Calculate the rocker arm-to-shaft clearance.

**SERVICE LIMIT: 0.08 mm (0.003 in)**





### CAMSHAFT BEARING INSPECTION

Install the cylinder head cover with 8 mm nuts.

**TORQUE: 1.8–2.0 kg-m (13–14 ft-lb)**

Measure the camshaft bearing I.D.

Calculate the camshaft-to-bearing clearance.

**SERVICE LIMIT: 0.10 mm (0.004 in)**



### CAMSHAFT BUSHING INSPECTION

Measure the camshaft bushing I.D.

Calculate the camshaft bushing-to-camshaft clearance.

**SERVICE LIMIT: 0.10 mm (0.004 in)**



### CYLINDER HEAD REMOVAL

Remove the cylinder head cover (Page 6–5).  
Remove the carburetor insulator.

Remove the cam chain tensioner bolt.  
Remove the cylinder head bolts.  
Remove the cylinder head.

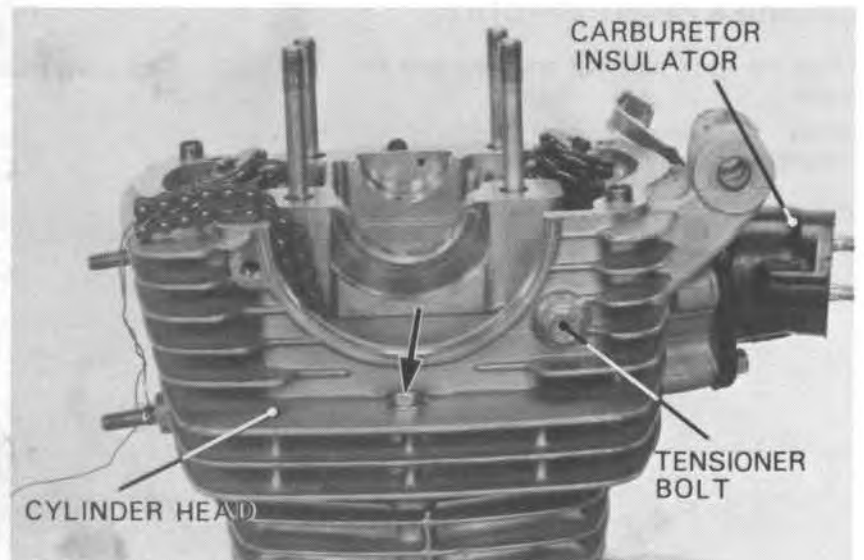



**CYLINDER HEAD/VALVES**

**CYLINDER HEAD DISASSEMBLY**

Remove the valve cotters, spring retainers and valve springs with a valve spring compressor.



VALVE SPRING COMPRESSOR  
07757-0010000 or 07957-3290001

Remove carbon deposits from the combustion chamber.  
Clean off any gasket material from the cylinder head surface.

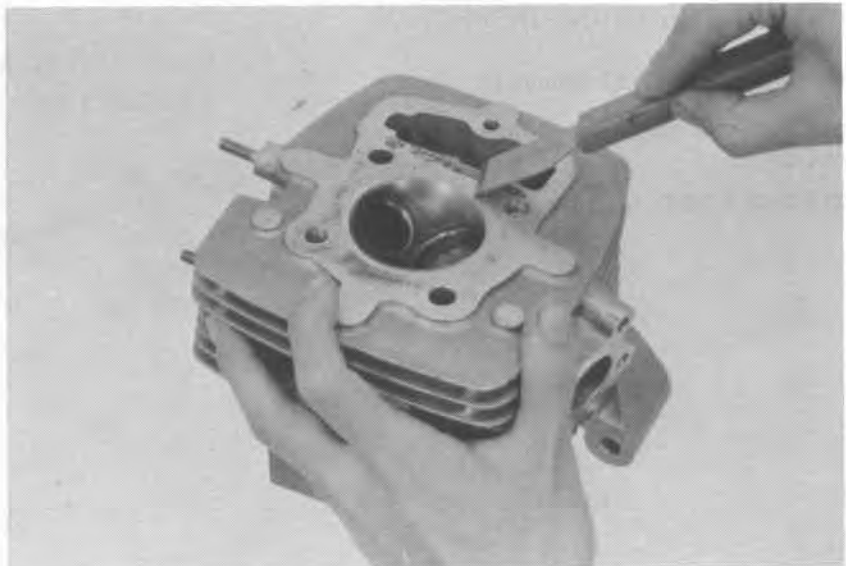

**CYLINDER HEAD INSPECTION**

Check the spark plug hole and valve area for cracks.

Check the cylinder head diagonally for warpage with a straight edge and feeler gauge.

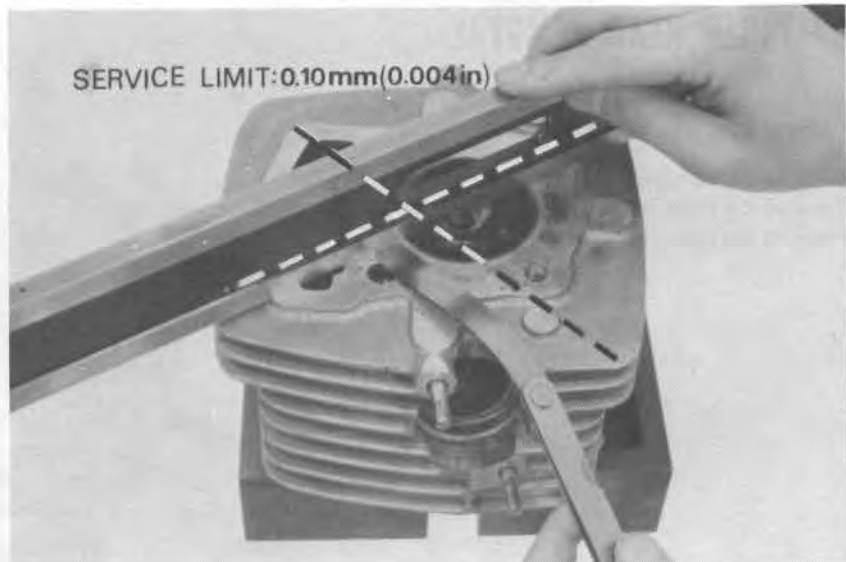

SERVICE LIMIT: 0.10mm(0.004in)



**VALVE SPRING INSPECTION**

Measure the free length of the inner and outer valve springs.

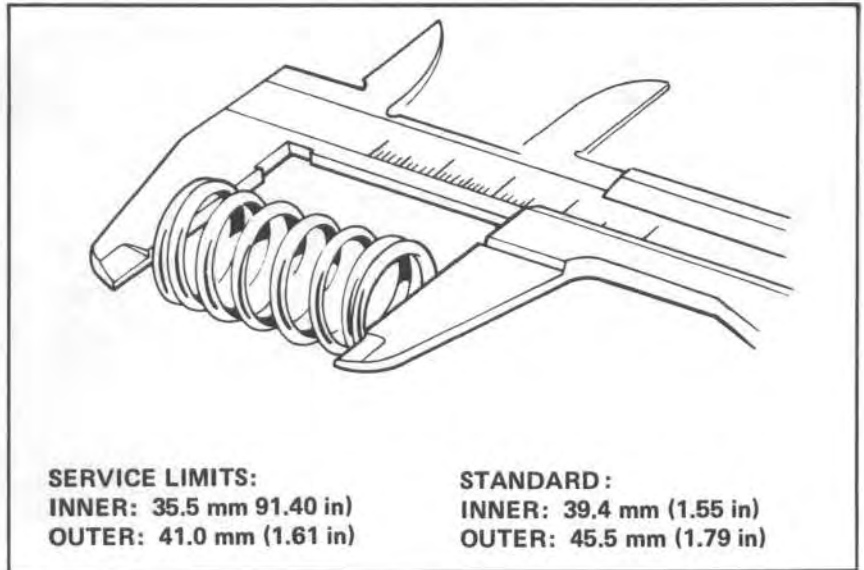

**VALVE/VALVE GUIDE INSPECTION**

Inspect each valve for trueness, burning, scratches or abnormal stem wear. Check the valve movement in the guide. Measure and record each valve stem O.D.

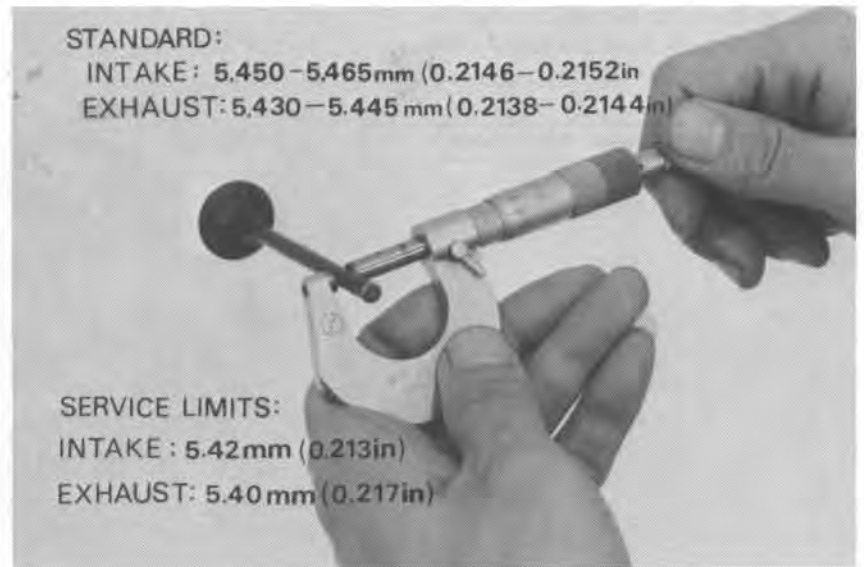

Measure and record the valve guide I.D.

**NOTE**

Ream the guides to remove any carbon build up before checking the valve guide I.D.

Calculate the stem-to-guide clearance.

**SERVICE LIMITS:**

IN: 0.12 mm (0.005 in)  
EX: 0.14 mm (0.006 in)

**NOTE**

- If the stem-to-guide clearance exceeds the service limit, determine if a new guide with standard dimensions would bring the clearance within tolerance. If so, replace guides as necessary and ream to fit.
- If the valve guide is replaced, the valve seat must be refaced.

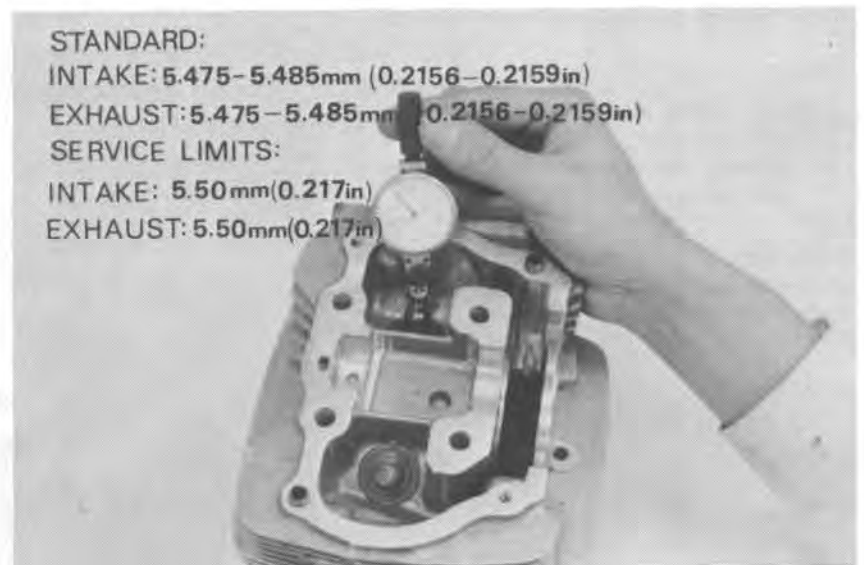



**CYLINDER HEAD/VALVES**

**VALVE GUIDE REPLACEMENT**

Support the cylinder head and drive out the guide from the valve port with a valve guide remover.

**NOTE**

When driving out the guide, do not damage the head.



**VALVE GUIDE REMOVER**  
5.5mm

(07942-3290100  
07942-9350000  
or  
07742-0010100

Install an O-ring on the new valve guide. Drive in the guide from the top of the head.

**NOTE**

Inspect the valve guide for damage.



**VALVE GUIDE DRIVER B**

(07942-3290200  
07942-9350000  
or  
07742-0020200

Ream the new valve guide after installation.

**NOTE**

- Use cutting oil on the reamer during this operation.
- Rotate the reamer when inserting and removing it.

Clean the cylinder head thoroughly to remove any metal particles. Reface the valve seat.

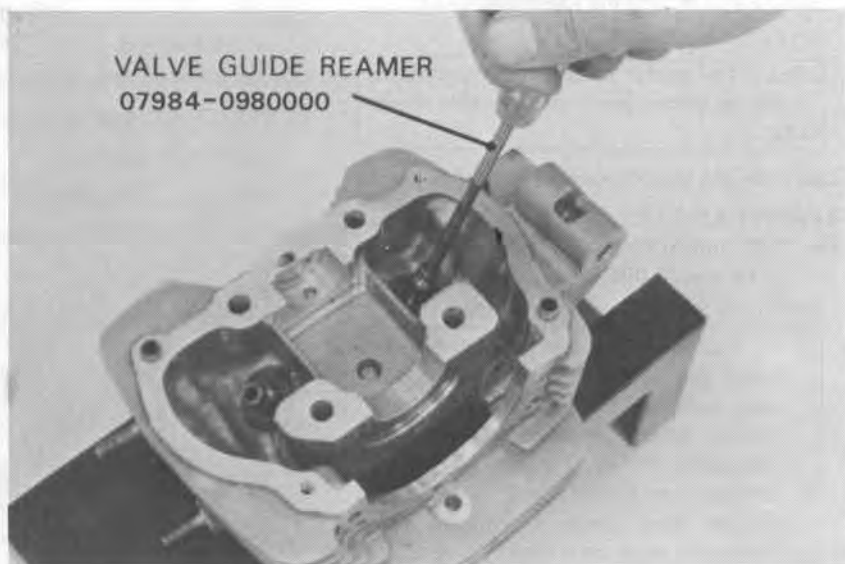

**VALVE GUIDE REAMER**  
07984-0980000



## VALVE SEAT INSPECTION/ REFACING

Clean all intake and exhaust valves thoroughly to remove carbon deposits.

Apply a light coating of Prussian Blue to each valve seat. Lap each valve and seat using a rubber hose or other hand-lapping tool. Remove and inspect each valve.

**CAUTION:**

*The valve cannot be ground. If the valve face is burned or badly worn or if it contacts the seat unevenly, replace the valve.*

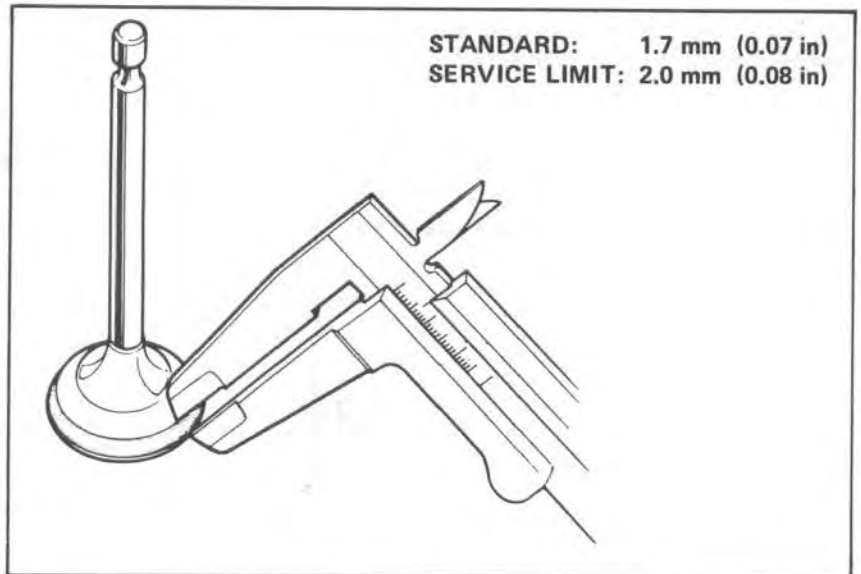

Inspect each valve seat.

If the seat is too wide, too narrow, or has low spots, the seat must be refinished to seal properly.

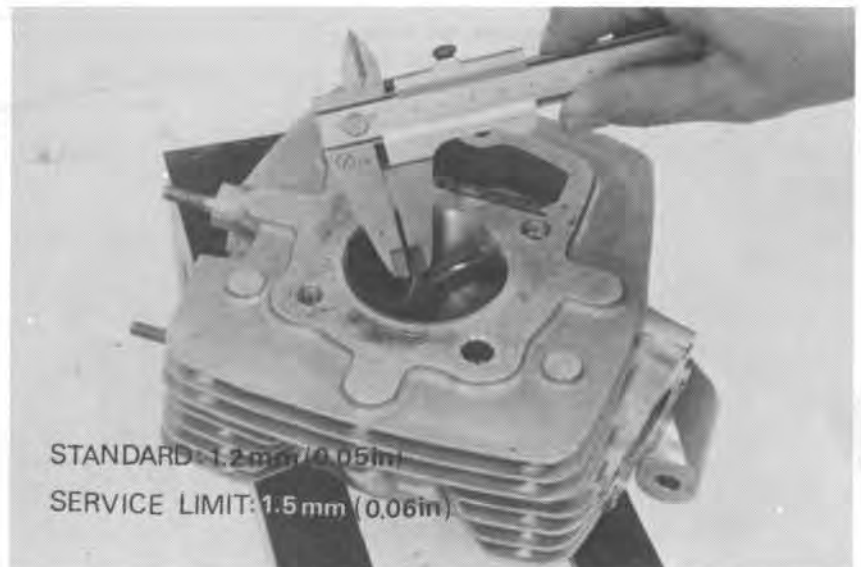

## VALVE SEAT GRINDING

HONDA VALVE SEAT CUTTERS, grinder or equivalent valve seat refacing equipment are recommended to correct a worn valve seat.

Follow the instructions supplied with the Valve Seat Refacing Equipment.

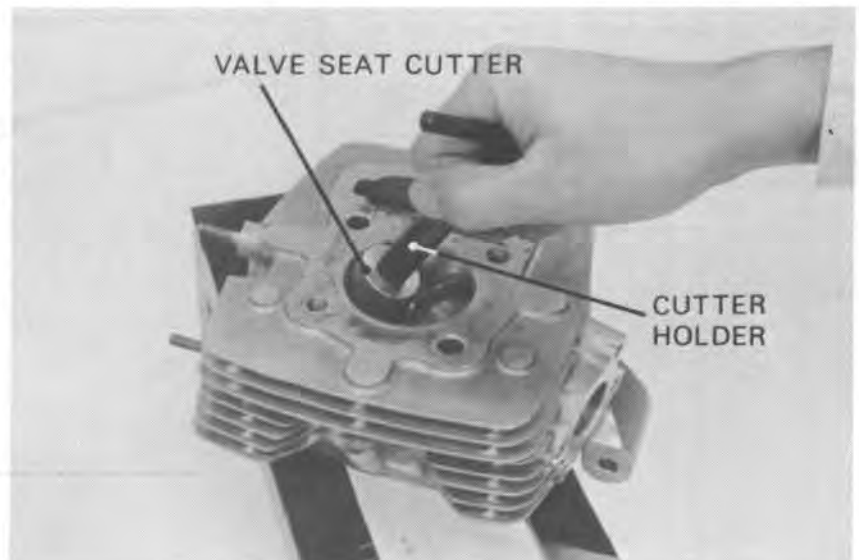



**CYLINDER HEAD/VALVES**

Use a 45 degree cutter to remove any roughness or irregularities from the seat.

**NOTE**

Reface the seat with a 45 degree cutter when the valve guide is replaced.

Use a 32 degree cutter to remove 1/4 of the existing valve seat material.

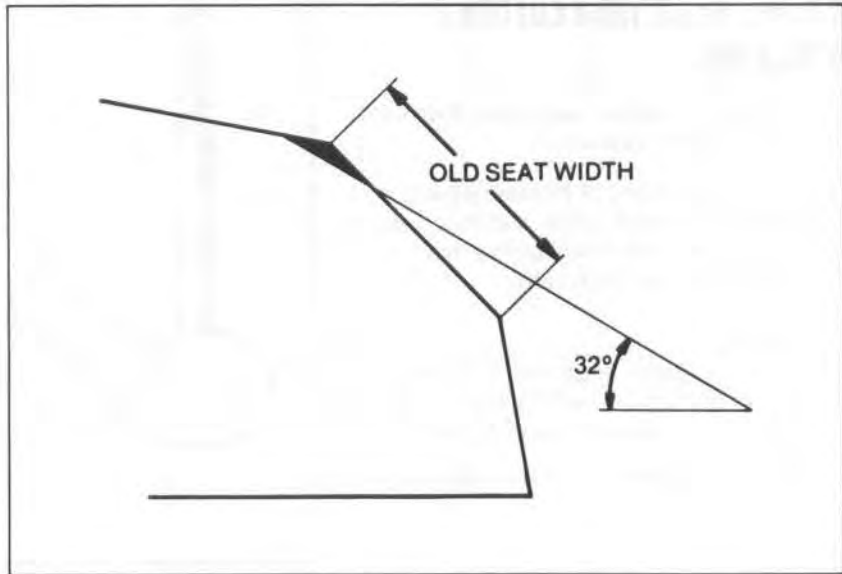

Use a 60 degree cutter to remove the lower 1/4 of the old seat. Remove the cutter and inspect the area you have just cut.

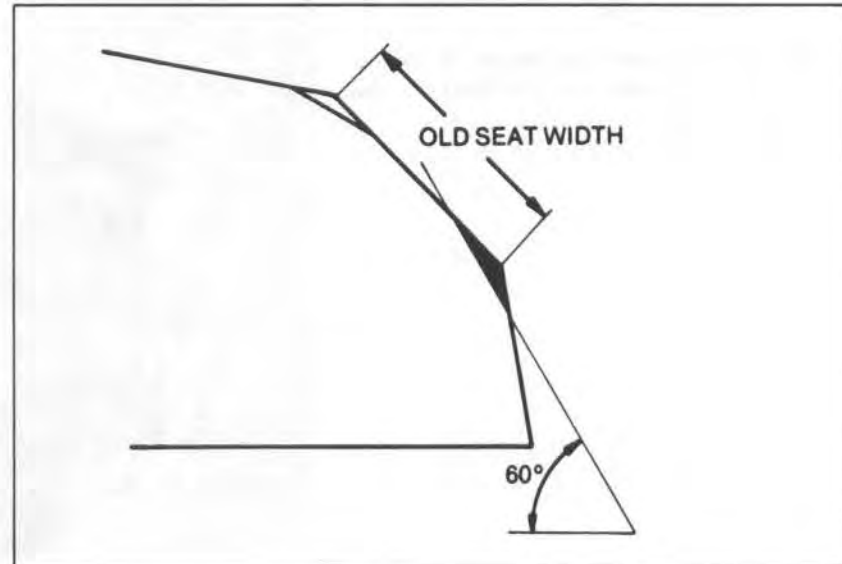

Install a 45 degree finish cutter and cut the seat to the proper width.

**NOTE**

Make sure that all pitting and irregularities are removed. Refinish if necessary.

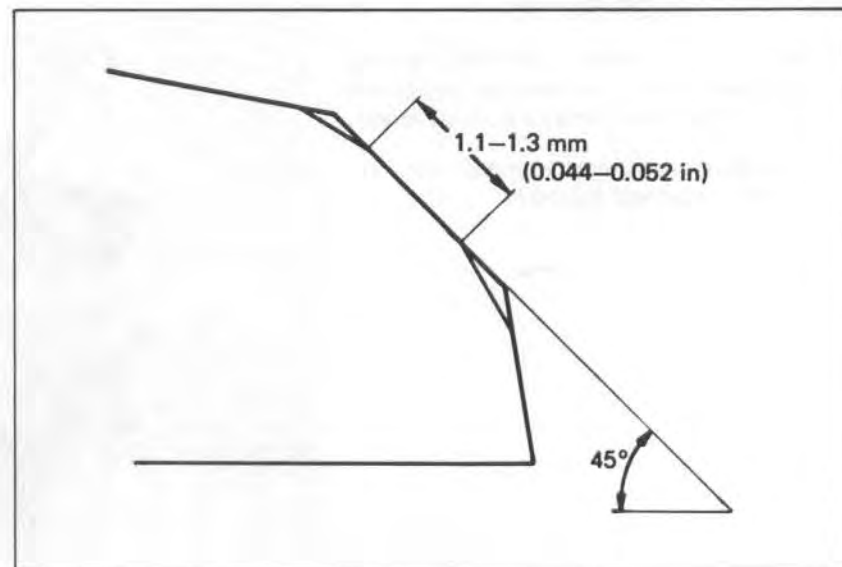





Apply a thin coating of Prussian Blue to the valve seat.

Press the valve through the valve guide and onto the seat without rotating it to make a clear pattern.

**NOTE**

The location of the valve seat in relation to the valve face is very important for good sealing.

If the contact area is too high on the valve, the seat must be lowered using a 32 degree flat cutter.

If the contact area is too low on the valve, the seat must be raised using a 60 degree inner cutter.

Refinish the seat to specifications using a 45 degree seat cutter.

After cutting the seat, apply lapping compound to the valve face and lap the valve using light pressure.

After lapping, wash all residual compound off the cylinder head and valve.

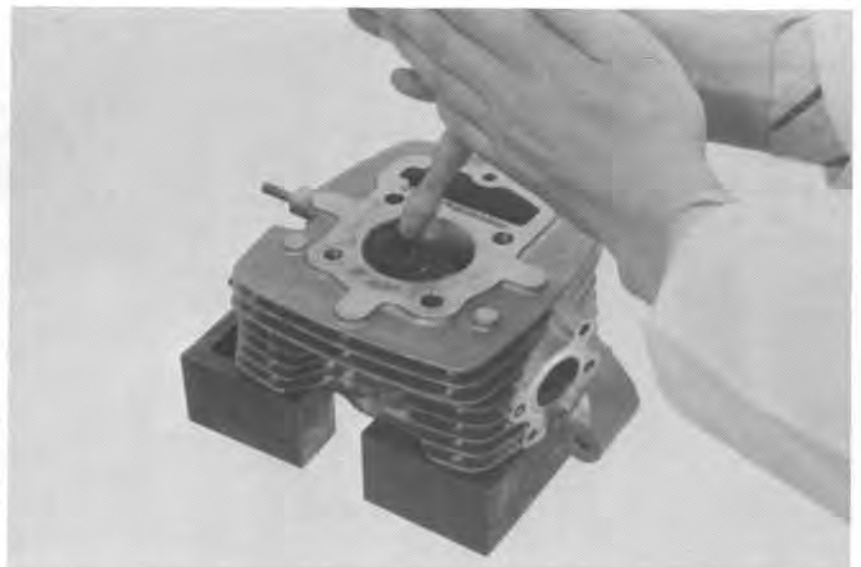
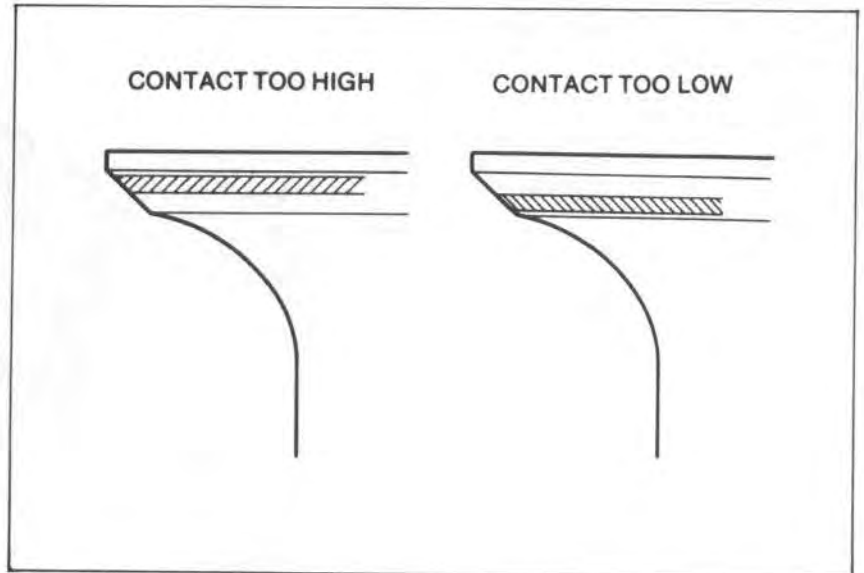

**CYLINDER HEAD ASSEMBLY**

**NOTE**

- Install new valve stem seals after disassembling.
- Install the valve springs with the tightly wound coils facing the cylinder head.

Lubricate each valve stem with oil.  
Insert the valves into the valve guides.

Install the valve spring seats.  
Install the valve springs.

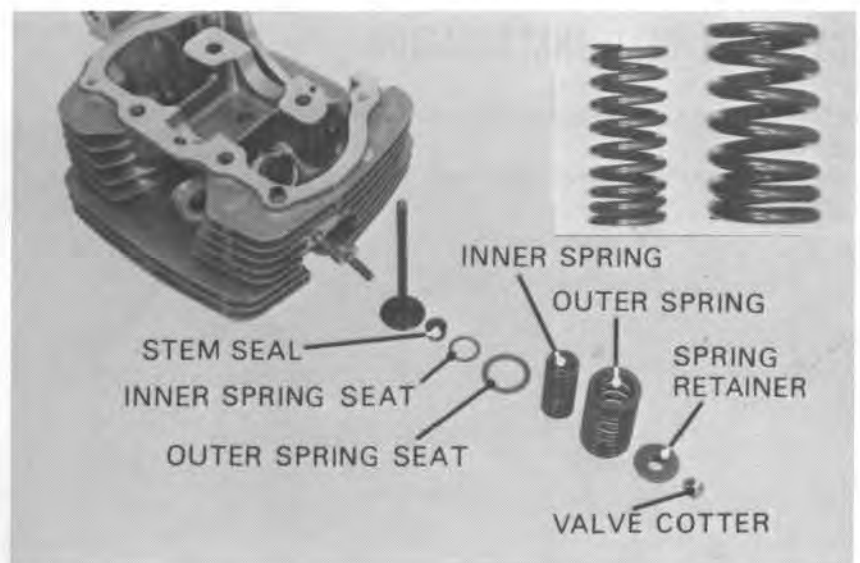



## CYLINDER HEAD/VALVES

Install the valve spring retainers.  
Install the valve cotters.

**CAUTION:**

*To prevent loss of tension, do not compress the valve spring more than necessary.*



Tap the valve stems gently with a plastic hammer to firmly seat the cotters.

**CAUTION:**

*Support the cylinder head above the work bench surface to prevent possible valve damage.*

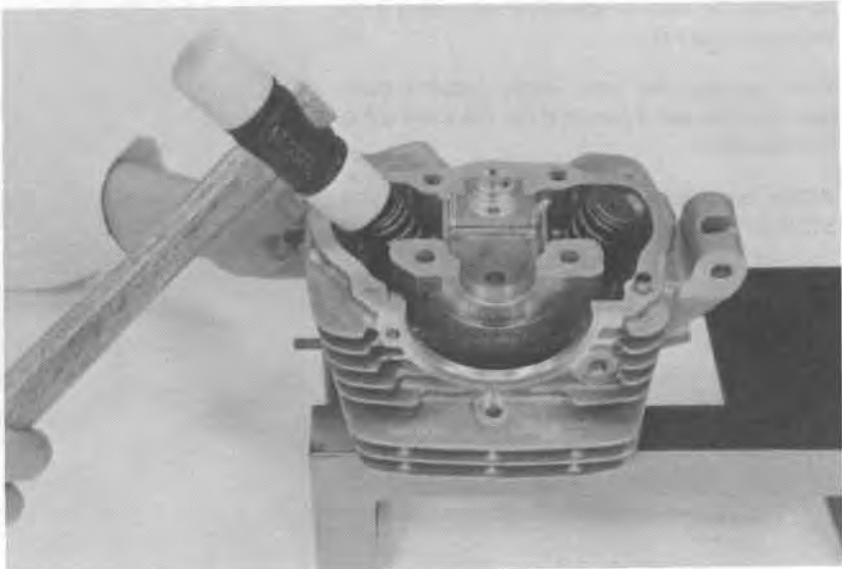

## CYLINDER HEAD INSTALLATION

Clean off any gasket material from the cylinder surface.  
Install the O-rings, dowel pins and a new gasket.

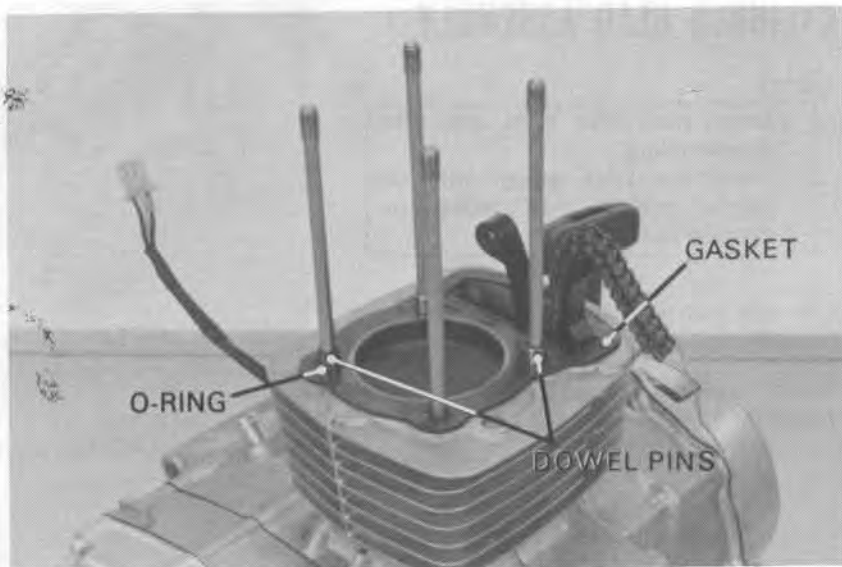



Remove the cam chain tensioner adjusting bolt rubber cap.  
Remove the check bolt and loosen the tensioner adjusting bolt.

Push the tensioner down with a screwdriver, as shown, while tightening the adjusting bolt. Install the check bolt and rubber cap.

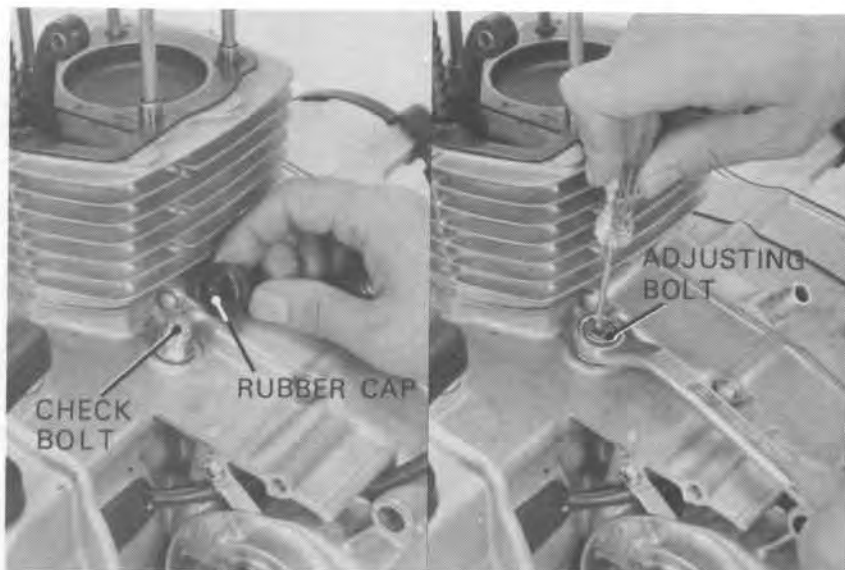

Install the cylinder head.  
Install the cylinder head bolts and tensioner bolt.



Install the dowel pins and camshaft bushings.

**NOTE**

Align the camshaft bushing dowel pin with the cutout in the cylinder head.

Install the oil hole plug.

Install the dowel pins.

Pour oil into the cylinder head oil pocket so the cam lobes will be lubricated.

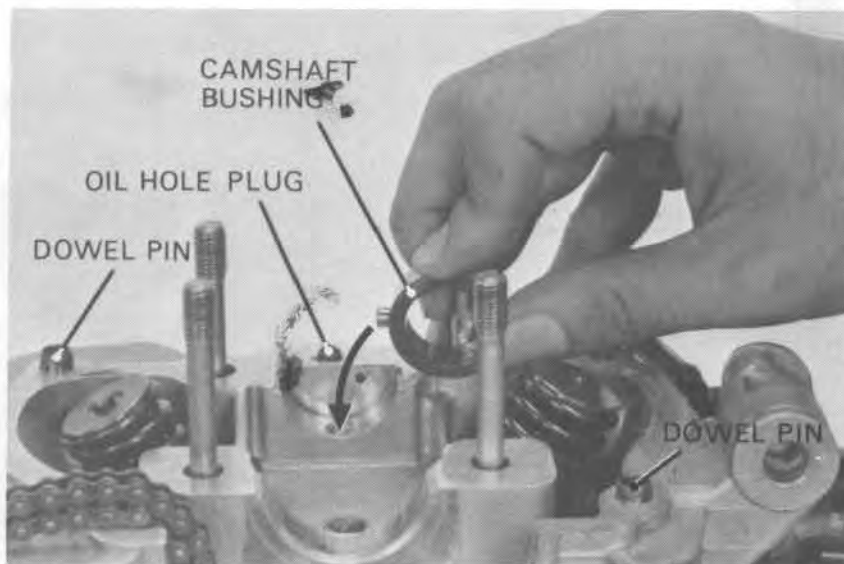



**CYLINDER HEAD/VALVES**

Install the carburetor insulator.

**NOTE**

Make sure that the O-ring is properly seated.

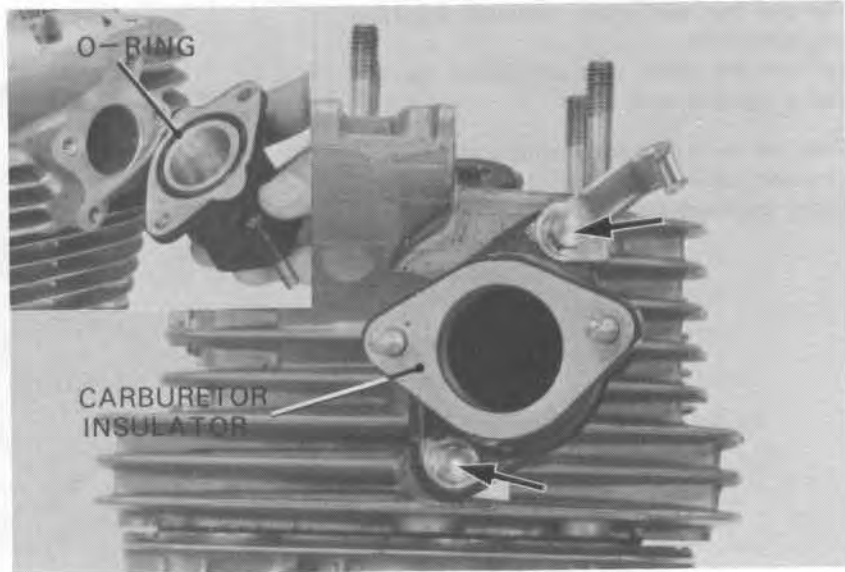

Install the rocker arms and rocker arm shafts in the cylinder head cover.  
Install the set plate and tighten the set plate screw.

Install the decompressor lever.  
Tighten the decompressor lever guide bolt.

**TORQUE: 0.5–0.7 kg-m (4–5 ft-lb)**

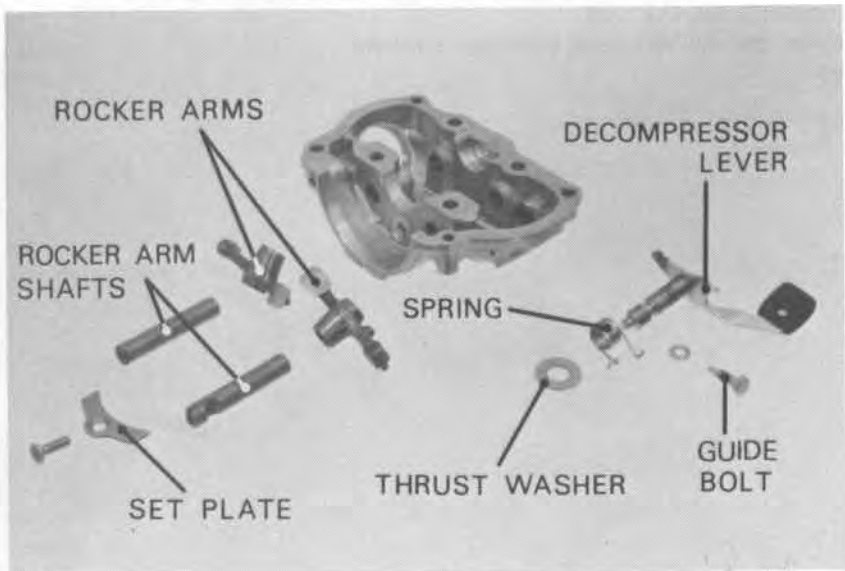

Loosen the valve adjusting screws.  
Apply liquid sealant to the cylinder head cover mating surface.

**NOTE**

Keep sealant away from the camshaft bearing surfaces.

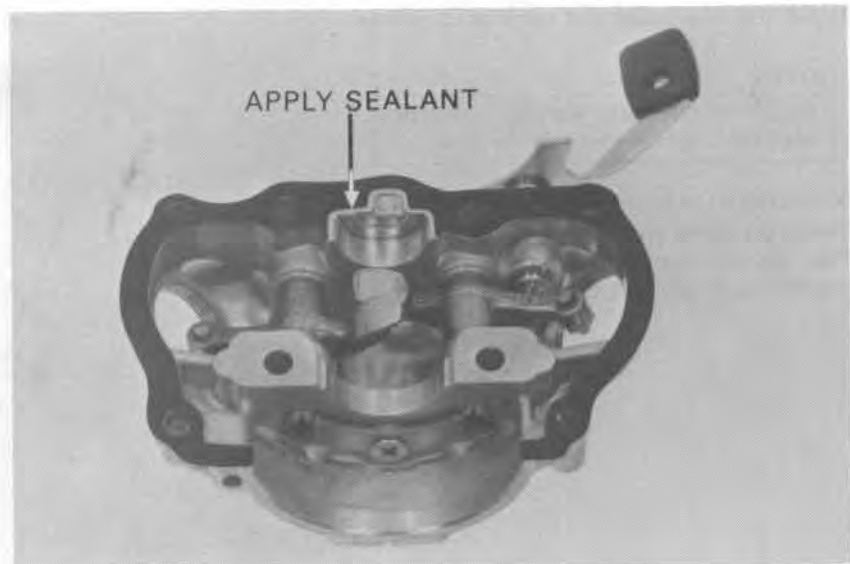



Coat the camshaft bearing and bushing with molybdenum disulfide grease.

Install the cylinder head cover.

Install and tighten the 8 mm cap nuts.

**TORQUE: 1.8–2.0 kg-m (13–14 ft-lb)**

Install and tighten the 6 mm socket bolts.

**TORQUE: 0.8–1.2 kg-m (6–9 ft-lb)**

**NOTE**

Tighten the 8 mm cap nuts and 6 mm bolts in a crisscross pattern in 2–3 steps.

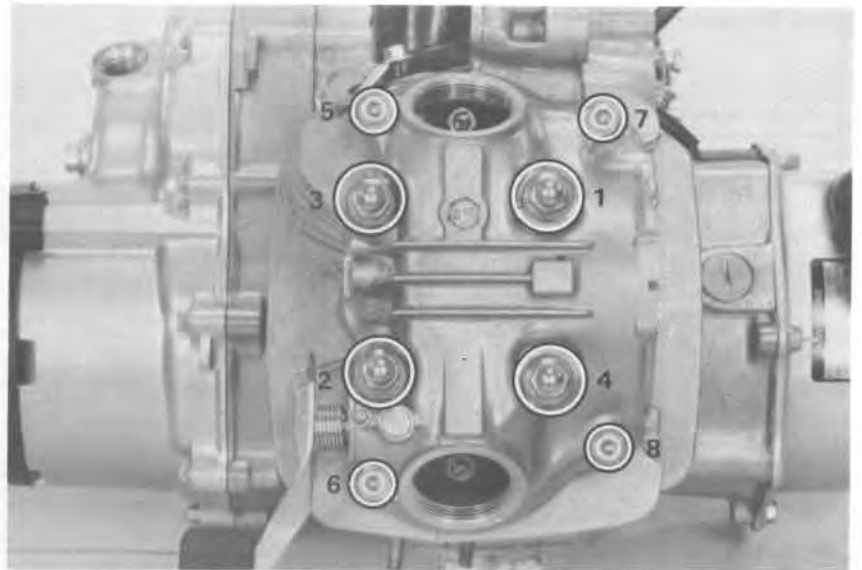

**CAMSHAFT INSTALLATION**

Coat the camshaft journals with molybdenum disulfide grease.

Place the thrust washer onto the camshaft.

Place the camshaft through the cam chain and into the cylinder head.

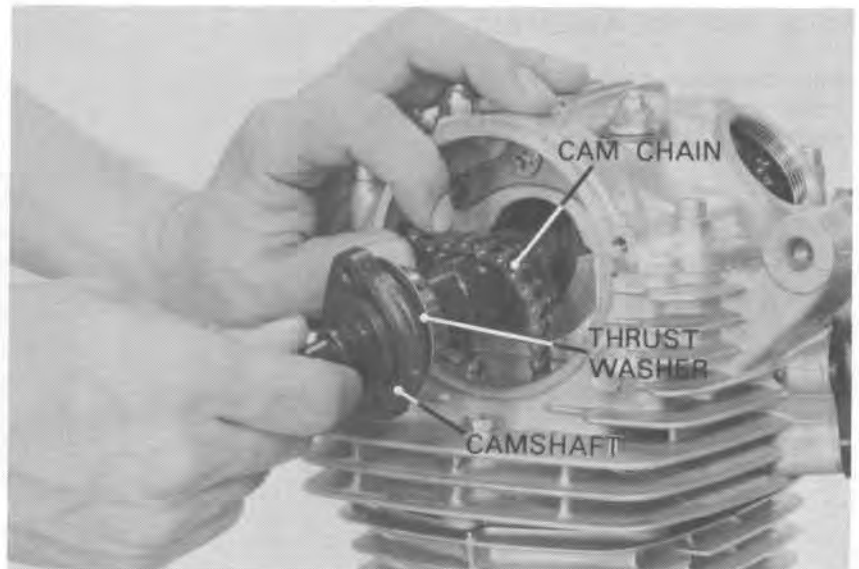

Turn the crankshaft counterclockwise and align the "T" mark with the index mark.  
Install the cam sprocket.

Align the timing mark "O" on the cam sprocket with the index mark on the cylinder head cover.

Tighten the cam sprocket bolt.

**TORQUE: 0.8–1.2 kg-m (6–9 ft-lb)**





**CYLINDER HEAD/VALVES**

Install the pulser base.

**NOTE**

Do not turn the oil seal lip inside out.

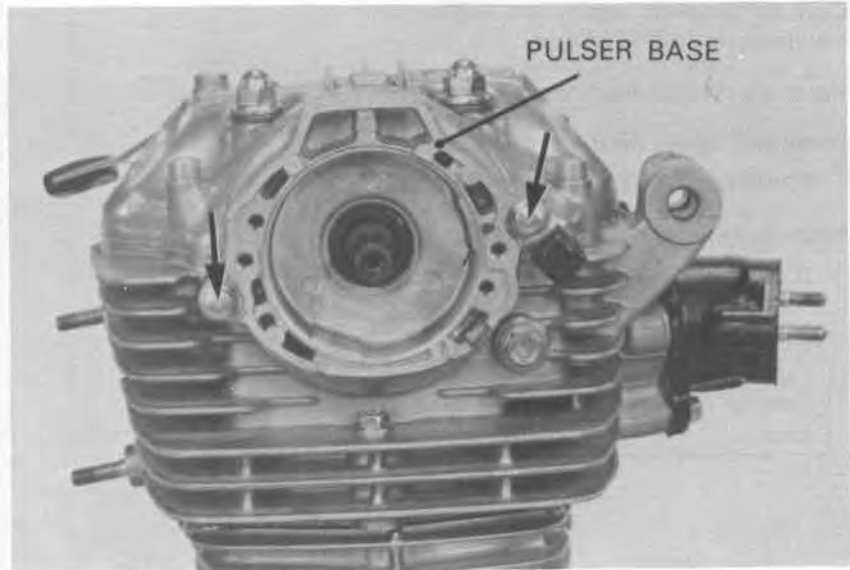

**PULSER ROTOR ASSEMBLY**

Align the punch mark on the rotor with the index mark on the spark advancer and assemble.

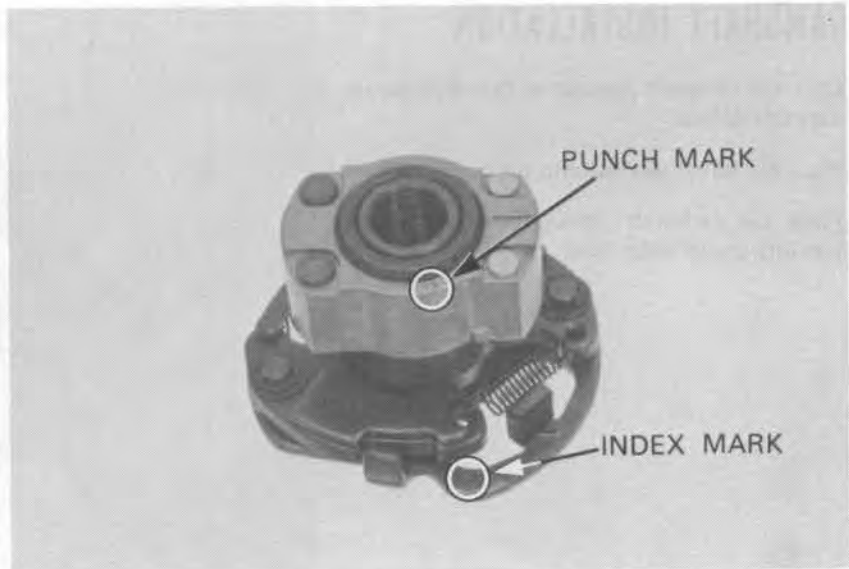

Install the dowel pins.  
Install the pulser rotor.

**NOTE**

Align the camshaft pin with the advancer groove.

Tighten the pulser rotor bolts.

**TORQUE: 0.8–1.2 kg-m (6–9 ft-lb)**

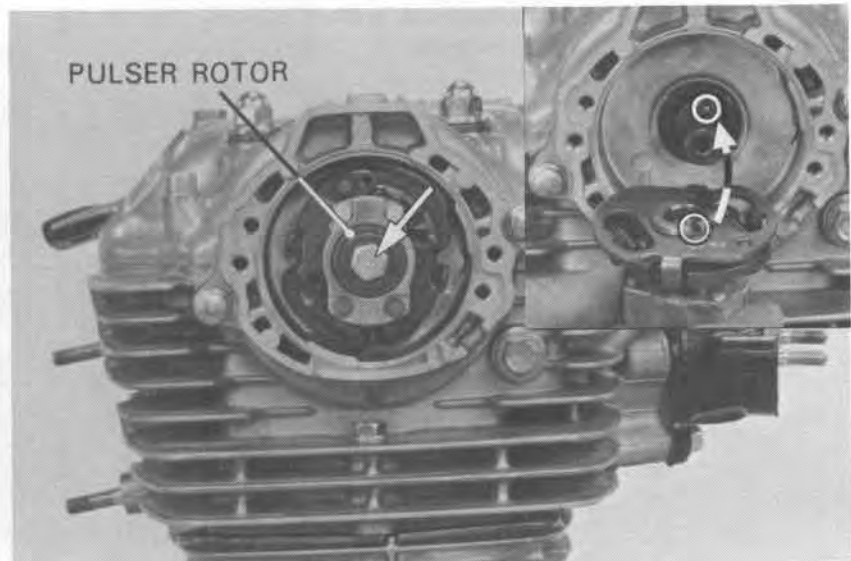



Install the pulser generator.  
Turn the crankshaft counterclockwise and align the "F" mark with the crankcase cover index mark.

Align the pulser rotor and pulser generator pulser generator index marks.  
Adjust the pulser rotor and generator air gap to 0.3–0.4 mm (0.012–0.016 in)

Install the pulser cover.  
Pour fresh oil into the oil pockes in the cylinder head so that the cam lobes are submerged.

Adjust the valve clearance (Page 3–5).  
Inspect and adjust the ignition timing (Page 15–6).

Test the cylinder compression (Page 3–8).  
Adjust the cam chain tension (Page 3–6).

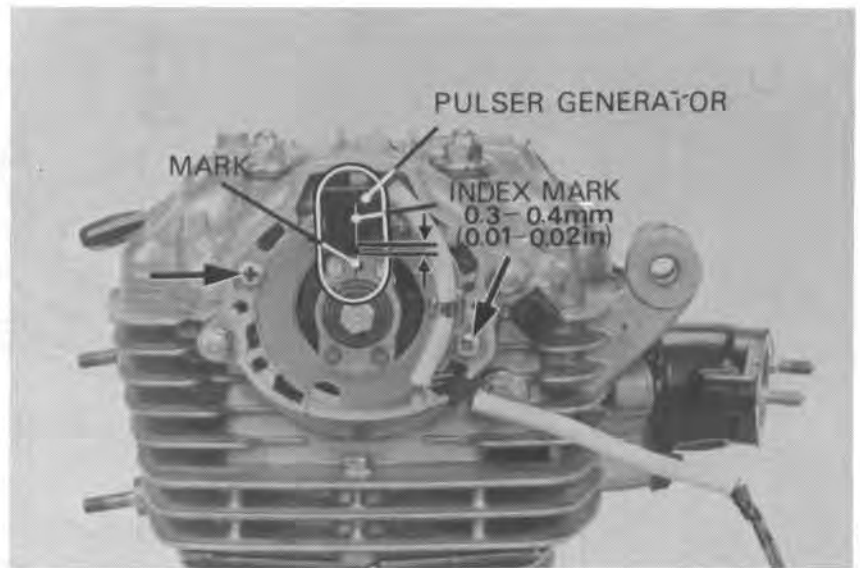

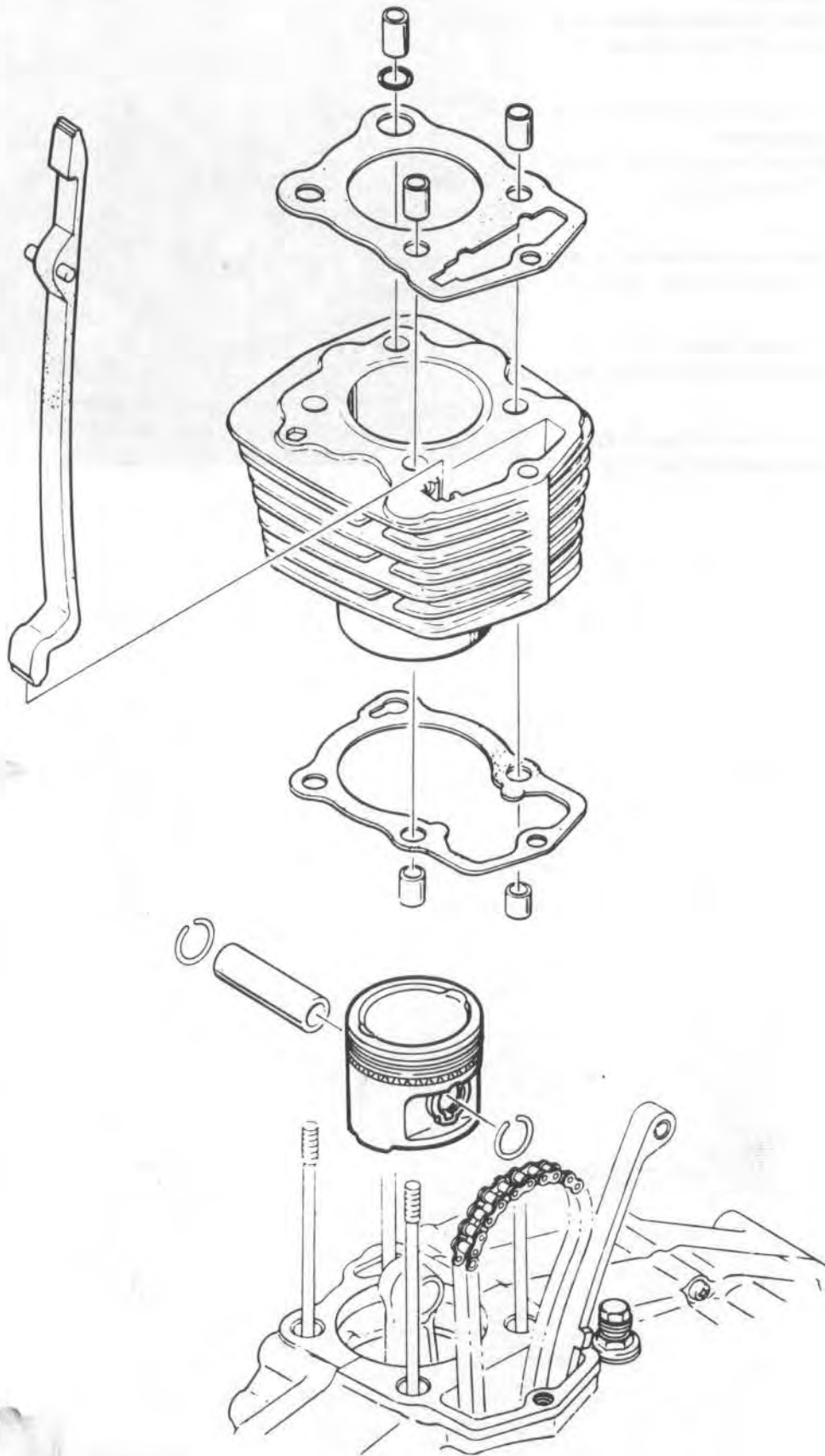





# 7. CYLINDER/PISTON

SERVICE INFORMATION	7-1
TROUBLESHOOTING	7-1
CYLINDER REMOVAL	7-2
PISTON REMOVAL	7-3
PISTON INSTALLATION	7-6
CYLINDER INSTALLATION	7-6

## SERVICE INFORMATION

### GENERAL INSTRUCTIONS

- Camshaft lubrication oil is fed to the cylinder head through an orifice in the cylinder and crankcase. Be sure this orifice is not clogged and that the O-rings and dowel pins are in place before installing the cylinder head.

### SPECIFICATIONS

ITEM		STANDARD	SERVICE LIMIT	
Cylinder	I.D.	63.000–63.010 mm (2.4803–2.4807 in)	63.10 mm (2.484 in)	
	Taper	—————	0.10 mm (0.004 in)	
	Out of round	—————	0.10 mm (0.004 in)	
	Warpage across top	—————	0.10 mm (0.004 in)	
Piston, piston pin, piston rings	Piston O.D.	62.955–62.985 mm (2.4785–2.4797 in)	62.90 mm (2.476 in)	
	Piston pin bore	15.002–15.008 mm (0.5906–0.5909 in)	15.04 mm (0.592 in)	
	Piston pin O. D.	14.994–15.000 mm (0.5903–0.5906 in)	14.96 mm (0.589 in)	
	Piston-to-pin clearance	0.002– 0.014 mm (0.0001–0.0006 in)	0.02 mm (0.001 in)	
	Piston ring-to-ring groove clearance	TOP	0.015– 0.050 mm (0.0006–0.0020 in)	0.09 mm (0.004 in)
		SEC	0.015– 0.045 mm (0.0006–0.0018 in)	0.09 mm (0.004 in)
	Piston ring end gap	TOP/SEC	0.20 – 0.40 mm (0.008 –0.016 in)	0.50 mm (0.02 in)
OIL		0.20 – 0.90 mm (0.010 –0.040 in)	—————	
Cylinder-to-piston clearance		0.015– 0.055 mm (0.0006–0.0022 in)	0.10 mm (0.004 in)	

## TROUBLESHOOTING

### Low or unstable compression

1. Worn cylinder or piston rings
2. Faulty decompressor lever out of adjustment.

### Excessive smoke

1. Worn cylinder, piston, or piston rings
2. Improper installation of piston rings
3. Scored or scratched piston or cylinder wall

### Overheating

1. Excessive carbon build-up on piston or combustion chamber wall

### Knocking or abnormal noise

1. Worn piston and cylinder
2. Excessive carbon build-up



## CYLINDER REMOVAL

Remove the cylinder head (Section 6).  
Remove the gasket, dowel pins and O-ring.  
Remove the cam chain guide.

**NOTE**

Keep the cam chain from falling into the crankcase when removing the cylinder.

Remove the cylinder.  
Remove the gasket and dowel pins.

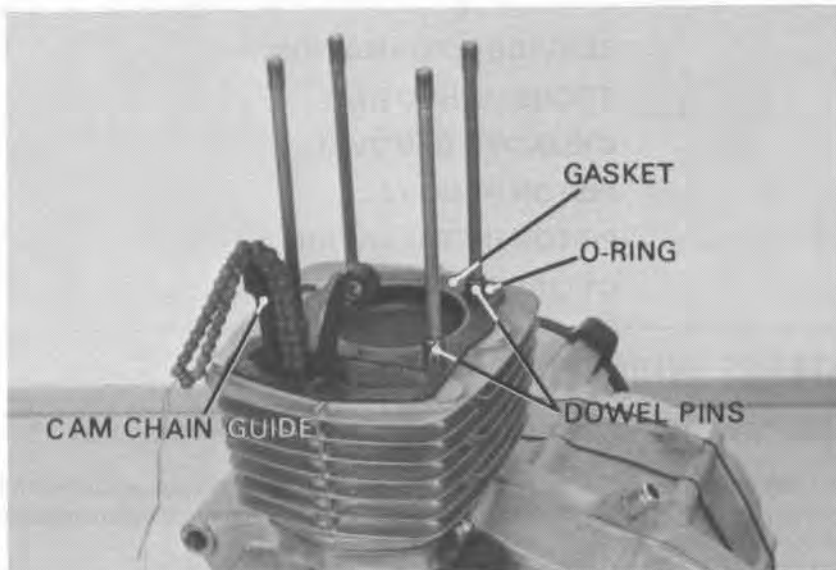

Clean off any gasket material from the cylinder surface.

**NOTE**

Do not remove metal from the gasket surface.



## CYLINDER INSPECTION

Inspect the cylinder bore for wear or damage.  
Measure the cylinder I.D.

**NOTE**

Check for cylinder I.D. at X and Y axis at three locations.

Calculate the taper and out of round.

**SERVICE LIMITS:**

**Taper:** 0.10 mm (0.004 in)  
**Out of round:** 0.10 mm (0.004 in)

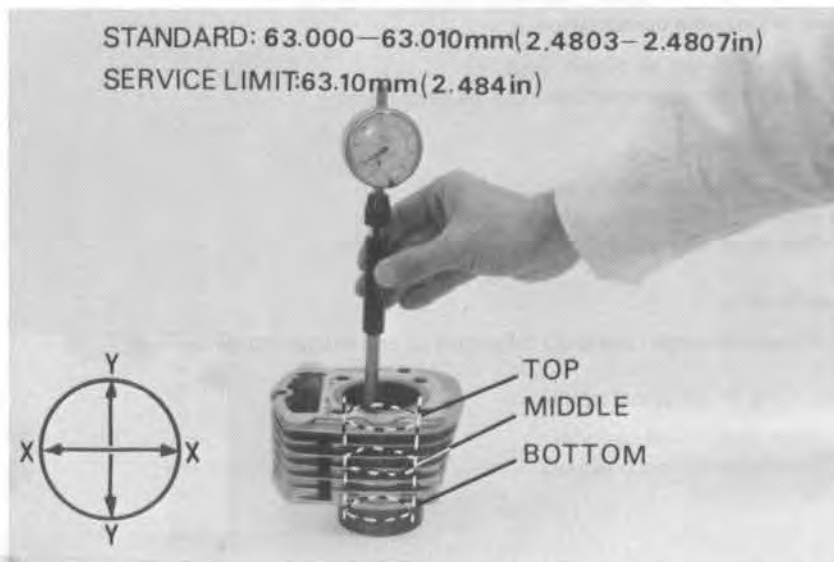



Inspect the top of the cylinder for warpage.



## PISTON REMOVAL

Remove the piston pin clip with pliers.

**NOTE**

Do not let the clips fall into the crank case.

Press the piston pin out of the piston.  
Remove the piston.

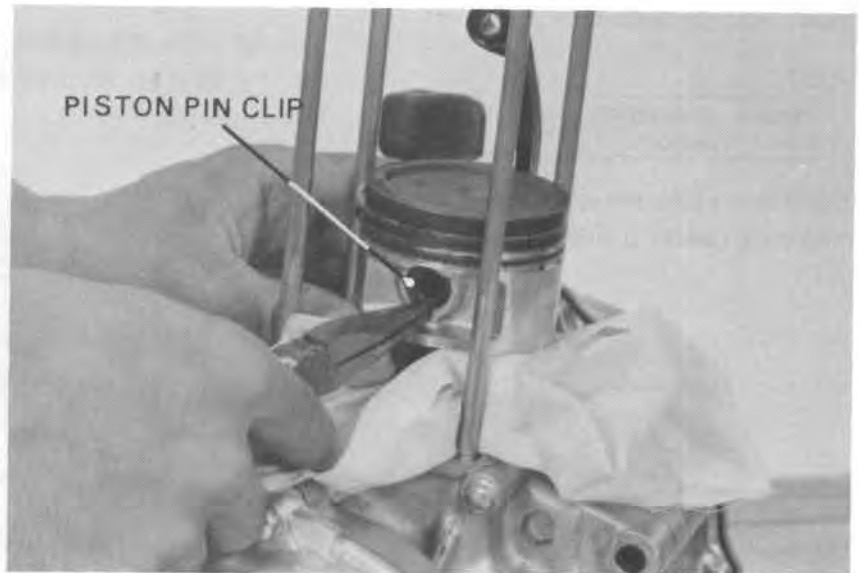

## PISTON/PISTON RING INSPECTION

Measure the piston ring-to-groove clearance.

Remove the piston rings.

**NOTE**

Do not damage the piston rings during removal.

Inspect the piston for wear or damage.

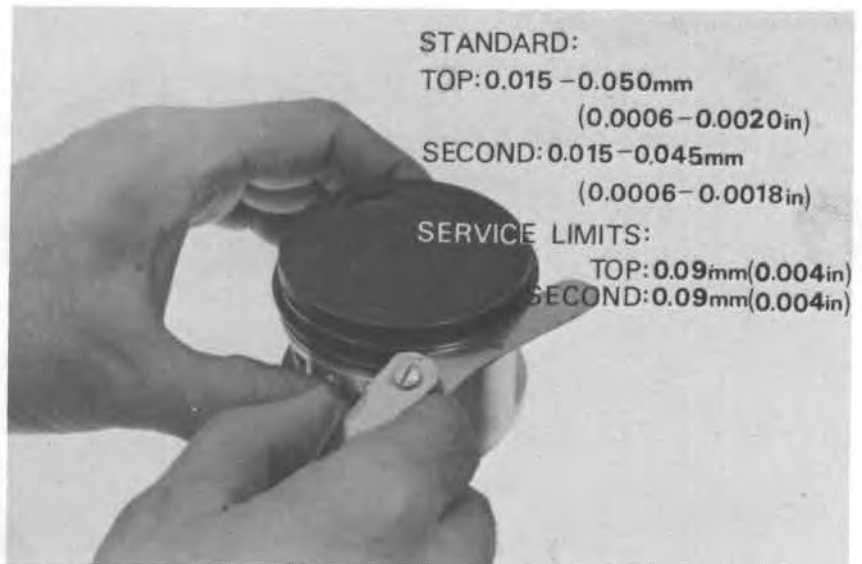



**CYLINDER/PISTON**

Insert each piston ring into the cylinder and measure the ring end gap.

STANDARD  
TOP: 0.20-0.40mm (0.008-0.016in)  
SECOND: 0.20-0.40mm (0.008-0.016in)  
SERVICE LIMITS:  
TOP: 0.5mm (0.02in)  
SECOND: 0.5mm (0.02in)



Measure the piston diameter at the skirt.

**NOTE**

Measure the piston diameter 10 mm from the bottom.

Calculate the piston-to-cylinder clearance.

**SERVICE LIMIT: 0.10 mm (0.004 in)**

STANDARD: 62.955-6.2985mm (2.4785-2.4795in)  
SERVICE LIMIT: 62.90mm (2.476in)



Measure the piston pin hole I.D.

STANDARD: 15.002-15.008mm  
(0.5906-0.5909in)  
SERVICE LIMIT: 15.04mm (0.592in)





Measure the piston O. D.

Calculate the piston-to-piston pin clearance.

**SERVICE LIMIT: 0.02 mm (0.001 in)**



**PISTON RING INSTALLATION**

Clean the piston ring grooves thoroughly.  
Install the piston rings.

**NOTE**

- Avoid piston and piston ring damage during installation.
- Install the piston rings with the marking facing up.
- Do not mix the top and second rings.

Space the piston ring end gaps 120 degrees apart. Do not align the gaps in the oil rings (side rails).

After installation, the rings should be free to rotate in the ring grooves'

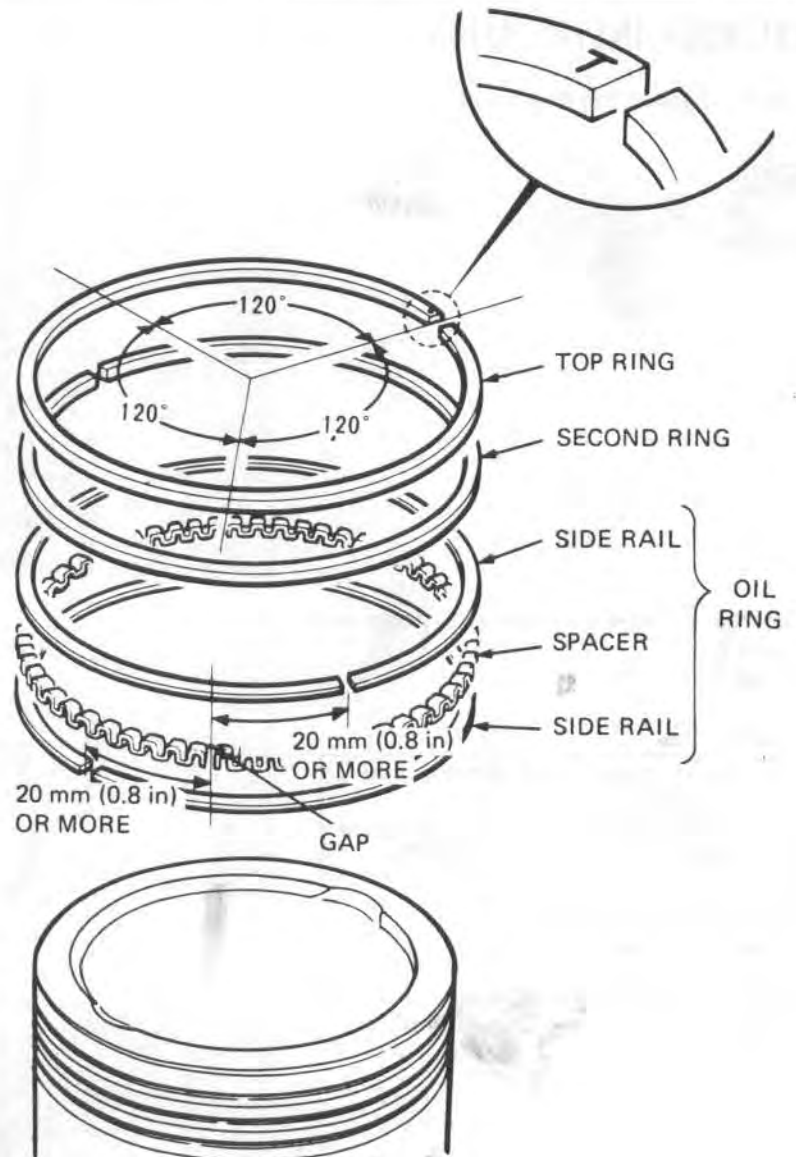
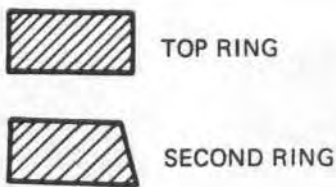



**CYLINDER/PISTON**

**PISTON INSTALLATION**

Install the piston and piston pin.  
Install new piston pin clips.

**NOTE**

- Position the piston "IN" mark on the intake valve side.
- Do not align the piston pin clip end gap with the piston cutout.
- Do not let the clip fall into the crankcase.

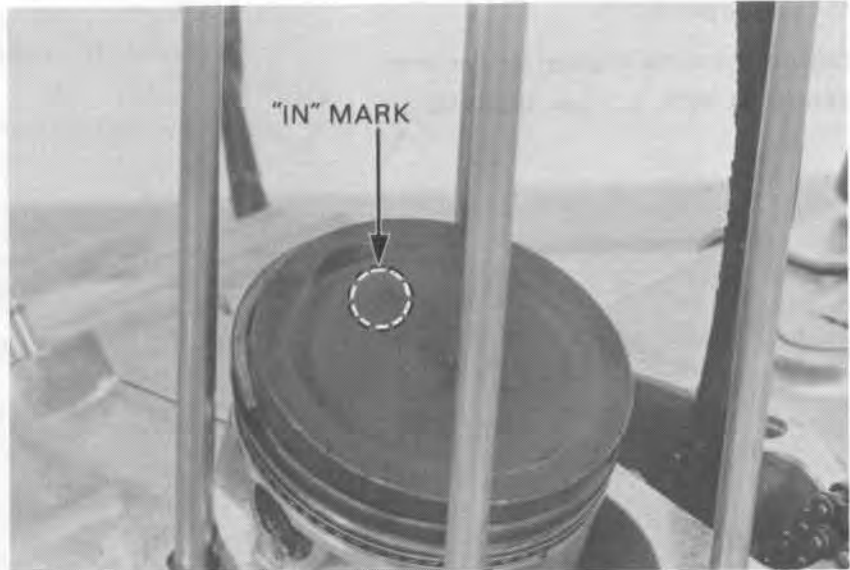

**CYLINDER INSTALLATION**

Install the gasket and dowel pins.

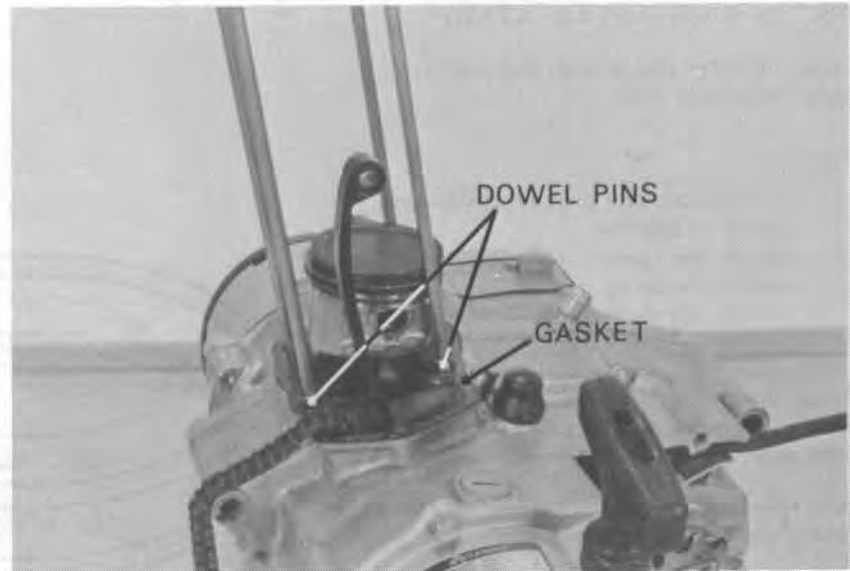

Coat the cylinder bore and piston rings with engine oil.  
Install the cylinder.

**NOTE**

- Avoid piston ring damage during installation.
- Do not let the cam chain fall into the crankcase.

Install the cam chain guide.  
Install a new gasket.

Install the dowel pins and O-ring.  
Install the cylinder head (Page 6-14).





**HONDA**  
**ATC185**

---

MEMO

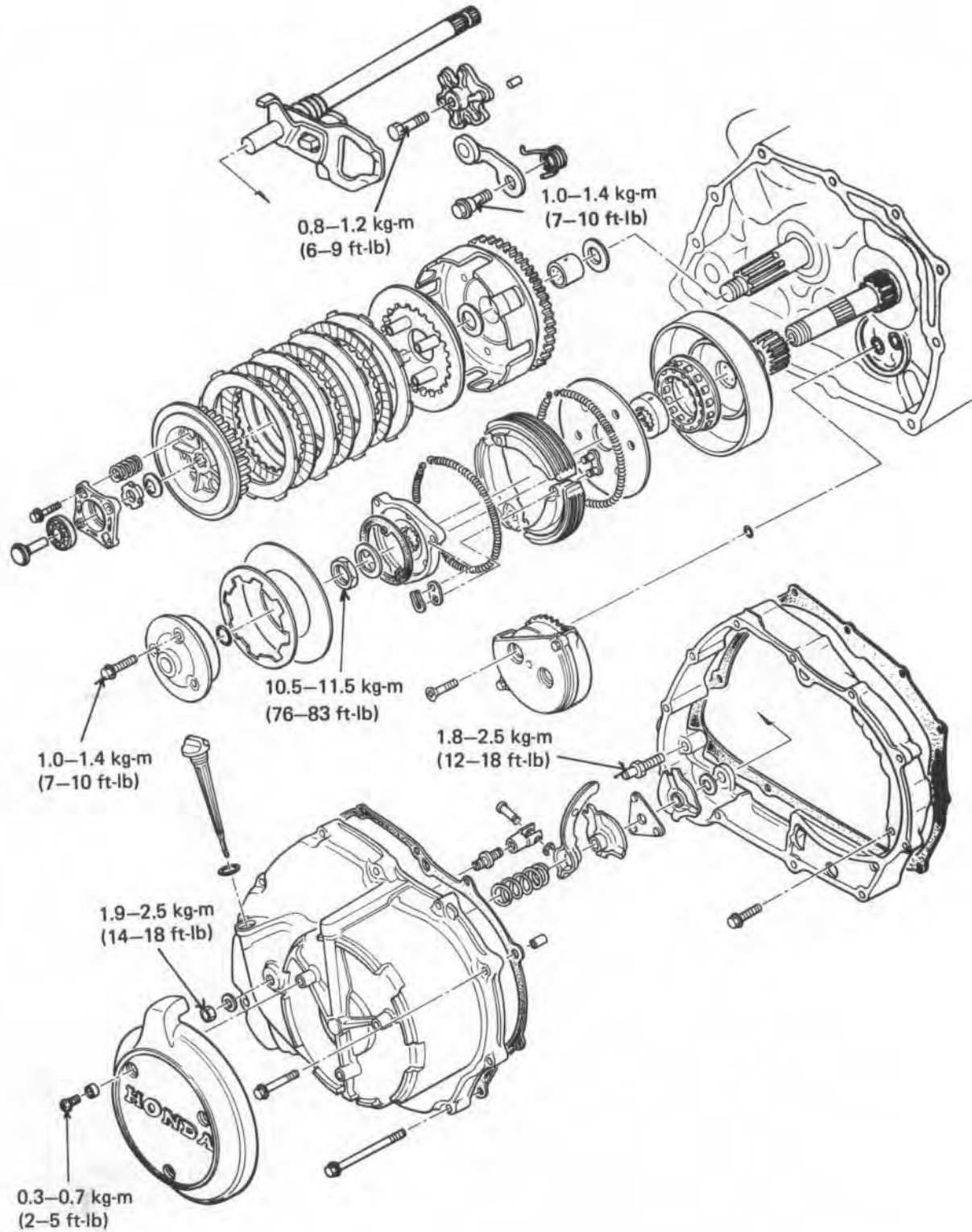





# 8. CLUTCH/OIL PUMP

SERVICE INFORMATION	8-1	MANUAL CLUTCH	8-11
TROUBLESHOOTING	8-2	OIL PUMP	8-15
RIGHT CRANKCASE COVER REMOVAL	8-3	GEARSHIFT LINKAGE	8-17
CENTRIFUGAL CLUTCH	8-5	RIGHT CRANKCASE COVER INSTALLATION	8-21

## SERVICE INFORMATION

### GENERAL INSTRUCTIONS

- This section covers removal and installation of the centrifugal clutch, manual clutch, oil pump and gearshift linkage.
- The clutches oil pump and gearshift linkage can be serviced with the engine installed in the frame.

### TOOLS

#### Common

Lock Nut Wrench 20 x 24 mm                    07716-0020100 or 07916-3710000  
 Extension Bar                                        07716-0020500    commercially available

#### Special

Flywheel Holder                                    07925-9580000    Not available in USA  
 30 mm Lock Nut Wrench                        07907-6890100  
 Clutch Center Holder                            07923-9580000    Not available in USA

### TORQUE VALUES

Oil filter rotor cover bolt                        1.0-1.4 kg-m (7-10 ft-lb)  
 Manual clutch lock nut                            4.0-5.0 kg-m (29-36 ft-lb)  
 Centrifugal clutch lock nut                      10.5-11.5 kg-m (76-83 ft-lb)  
 Clutch adjusting screw lock nut                1.9-2.5 kg-m (14-18 ft-lb)  
 Clutch lifter stopper bolt                        1.8-2.5 kg-m (13-18 ft-lb)  
 Gearshift drum stopper arm bolt                1.0-1.4 kg-m (7-10 ft-lb)  
 Gearshift drum stopper plate bolt              0.8-1.2 kg-m (6-9 ft-lb)  
 Foot peg bolt                                        1.9-2.5 kg-m (14-18 ft-lb)

### SPECIFICATIONS

ITEM		STANDARD		SERVICE LIMIT	
Manual clutch	Spring free length	25.7 mm	(1.01 in)	25.0 mm	(0.98 in)
	Spring preload	37.5 kg	(86.70 lb)		
	Disc thickness	2.9-3.0 mm	(0.11-0.12 in)	2.6 mm	(0.10 in)
	Disc warpage			0.20 mm	(0.008 in)
	Plate warpage			0.20 mm	(0.008 in)
	Clutch outer guide	20.000-20.021 mm	(0.7874-0.7882 in)	20.05 mm	(0.7894 in)
Centrifugal clutch	Drum I.D.	116 mm	(4.57 in)	116.3 mm	(4.58 in)
	Weight thickness	4.3 mm	(0.17 in)	4.1 mm	(0.16 in)
	Spring free length	267.5 mm	(10.53 in)	282 mm	(11 in)
	Spring preload	12.3-13.7 kg	(27.1-30.21 lb)		
Oil pump	Rotor-to-cover clearance	0.15-0.20 mm	(0.006-0.008 in)	0.25 mm	(0.010 in)
	Rotor tip clearance	0.15 mm	(0.006 in)	0.20 mm	(0.008 in)
	Rotor-to-body clearance	0.30-0.36 mm	(0.012-0.014 in)	0.40 mm	(0.016 in)



**CLUTCH/OIL PUMP**

---

**TROUBLESHOOTING**

Faulty clutch operation can usually be corrected by adjusting the clutch.

**Clutch slips when accelerating**

1. Faulty clutch lifter
2. Discs worn
3. Spring weak

**Clutch will not disengage**

1. Faulty clutch lifter
2. Plates warped

**Motorcycle creeps with clutch disengaged**

1. Faulty centrifugal clutch
2. Plates warped

**Clutch operation feels rough**

1. Outer drum slots rough

**Hard to shift**

1. Stopper plate damaged
2. Incorrect clutch adjustment
3. Faulty clutch lifter

**Gearshift pedal will not return**

1. Weak or broken shift return spring
2. Shift spindle binding with case

**Transmission jumps out of gears**

1. Weak or broken stopper spring

**Low oil pressure**

1. Faulty oil pump
2. Oil pump drive gear broken



### RIGHT CRANKCASE COVER REMOVAL

Drain oil from the engine.  
Remove the right foot peg.

Remove the right crankcase cover bolts and cover.

Remove the gasket and dowel pins.

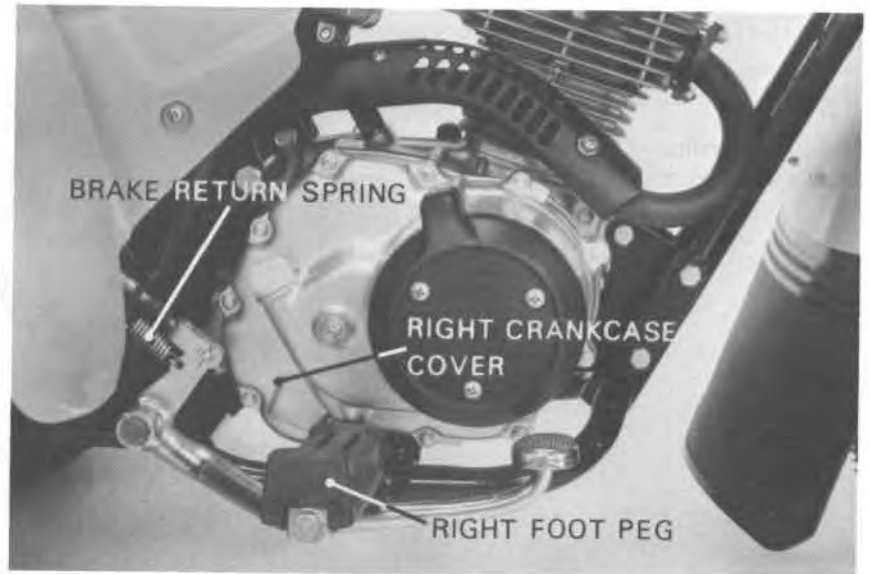

### CLUTCH LIFTER DISASSEMBLY

Remove the clutch adjusting screw lock nut, washer and O-ring.

Remove the clutch lifter lever and spring.

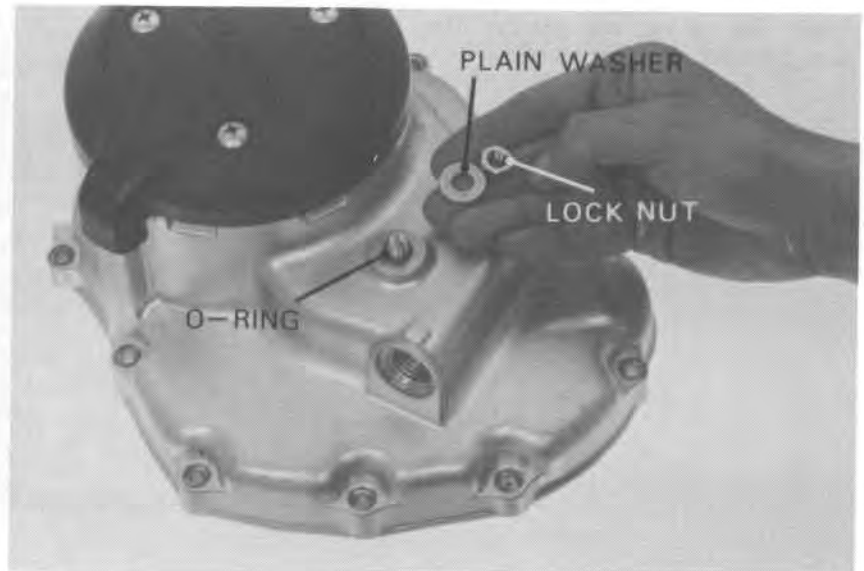

Remove the clutch adjusting screw.

Remove the circlip and disassemble the clutch lifter lever.

Check the disassembled parts for damage or wear.

Replace the parts if necessary.

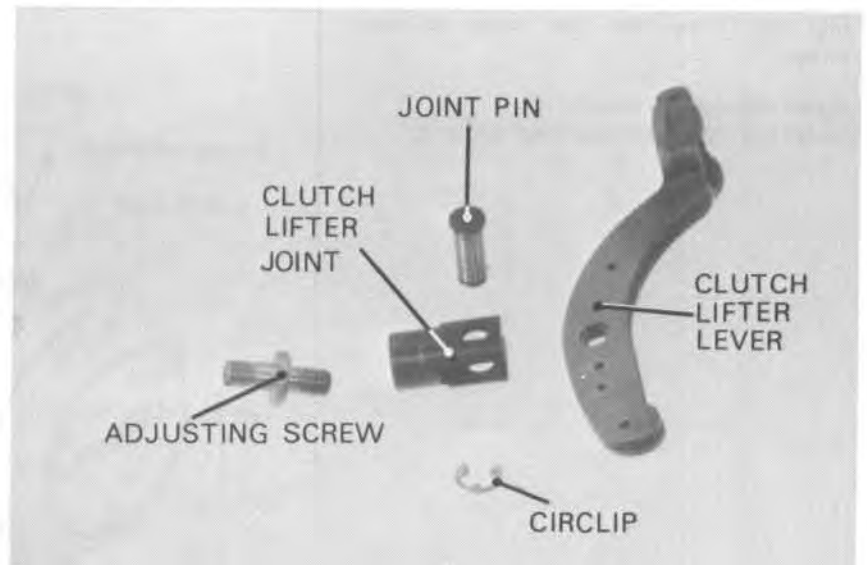



**CLUTCH/OIL PUMP**

**CLUTCH LIFTER ASSEMBLY**

Install the joint and joint pin on the lifter lever.

Install the circlip.  
Screw in the clutch adjusting screw.

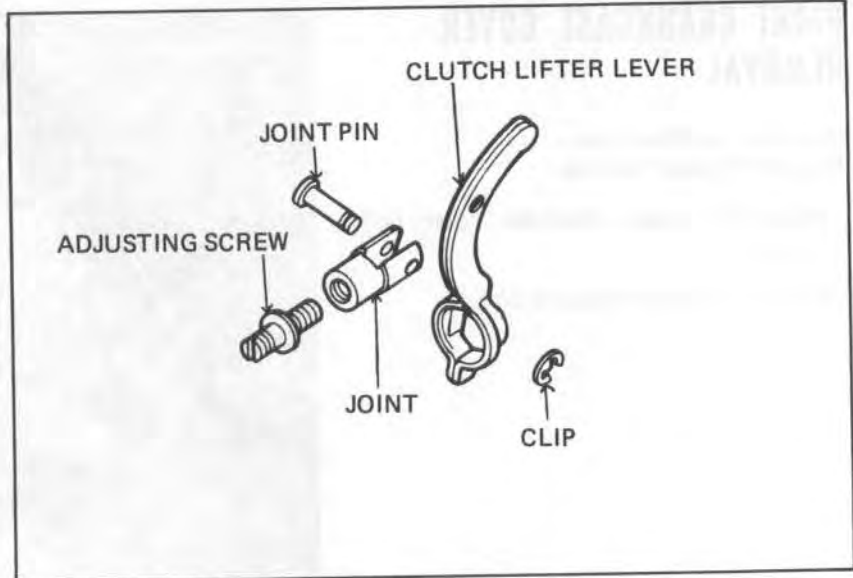

Install the spring and clutch lifter lever onto the right crankcase cover.

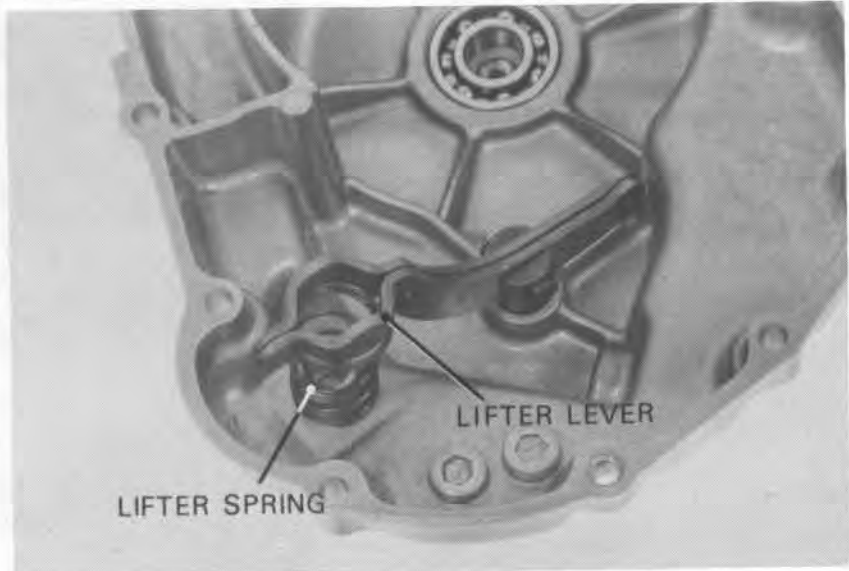

Slip the O-ring onto the clutch adjusting screw.

Install the lock nut loosely.  
Install the right crankcase cover protector.

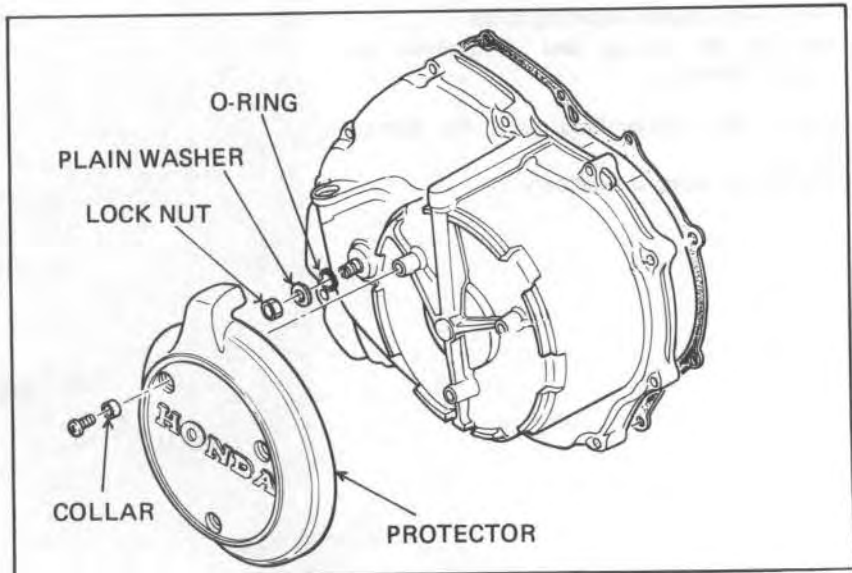



## CENTRIFUGAL CLUTCH

### CENTRIFUGAL CLUTCH REMOVAL

Remove the recoil starter from the left crankcase cover (Page 9-2)

Install a ROTOR HOLDER or screwdriver to prevent the crankshaft from turning.

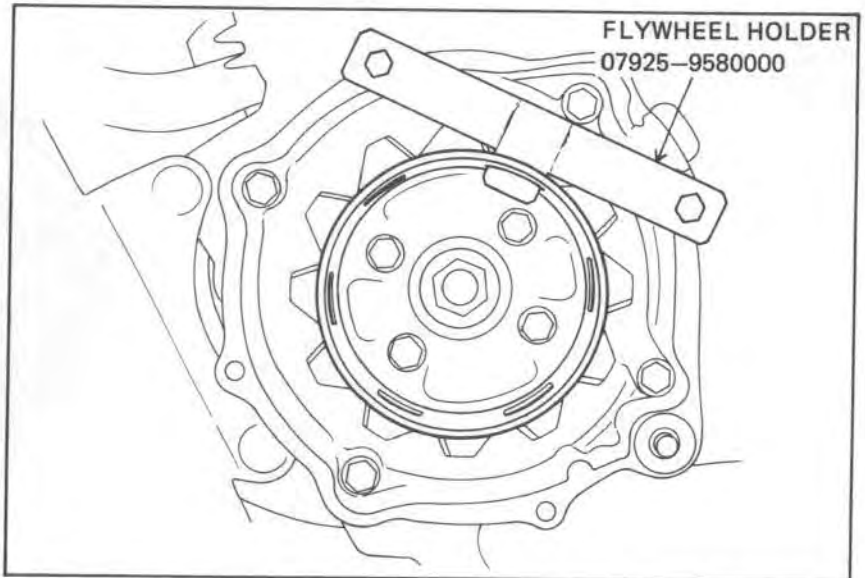

Remove the oil filter rotor cover, slide friction spring and plain washer.  
Remove the O-ring.

**CAUTION:**

*Use care to prevent oil pressure pad damage.*

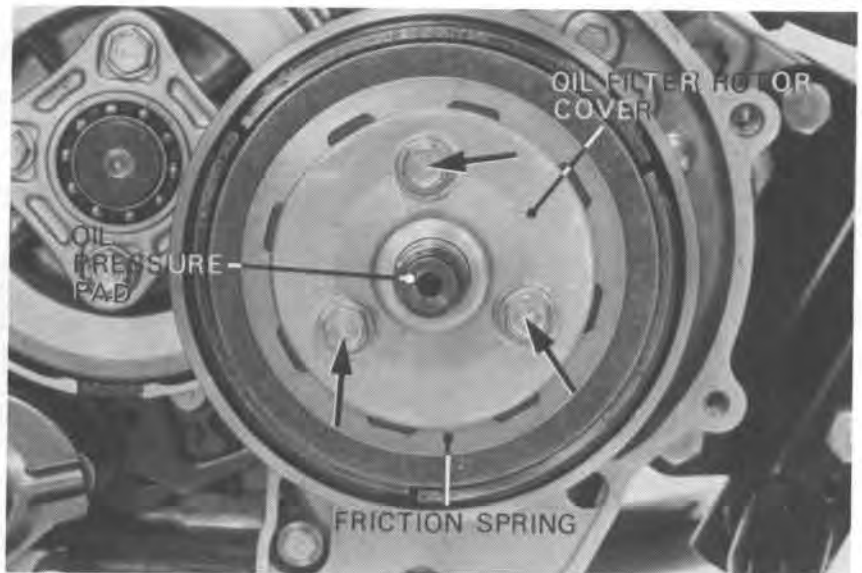

Remove the lock nut by turning it clockwise.

**NOTE**

*The lock nut has left hand threads.*

Remove the centrifugal clutch weights.





**CLUTCH/OIL PUMP**

Remove the springs.  
Remove the clips and centrifugal clutch weight.

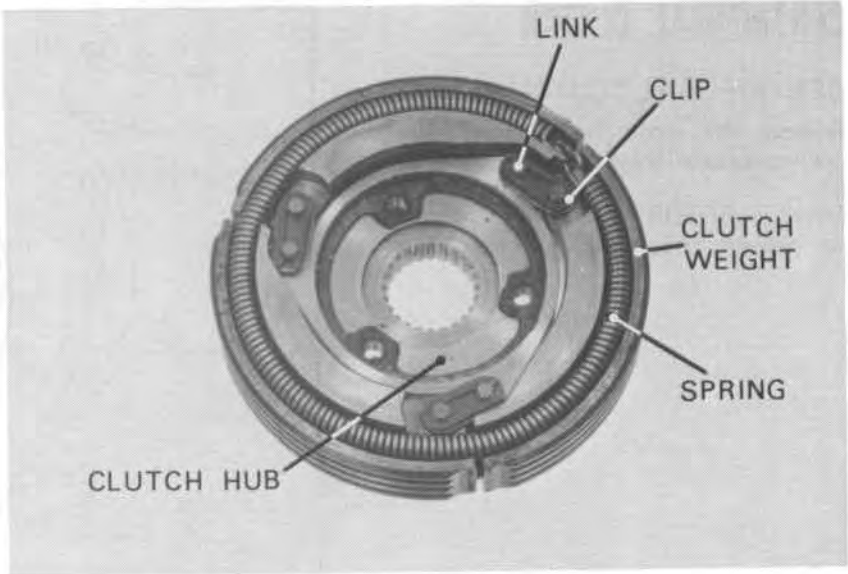

**WEIGHT INSPECTION**

Measure the weight lining thickness.  
Measure the link joint hole I. D.



Measure the weight spring free length.

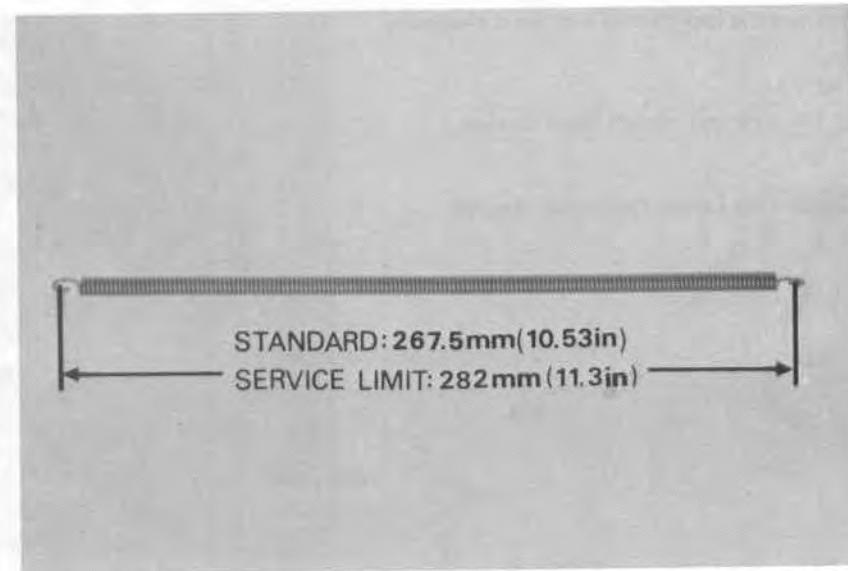



Remove the clutch plate.  
Align the clutch outer cutout with the drive gear.  
Remove the clutch drum.

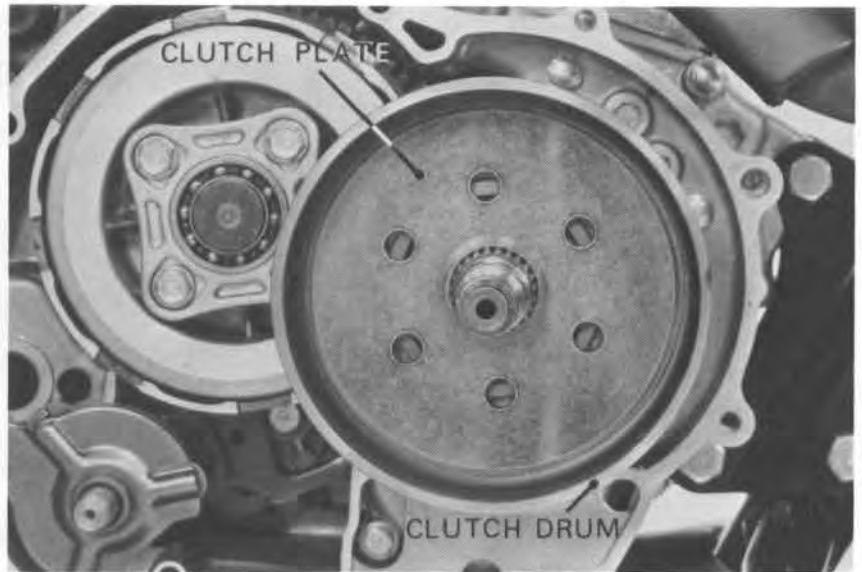

Remove the one-way clutch center.  
Remove the one-way clutch sprag.

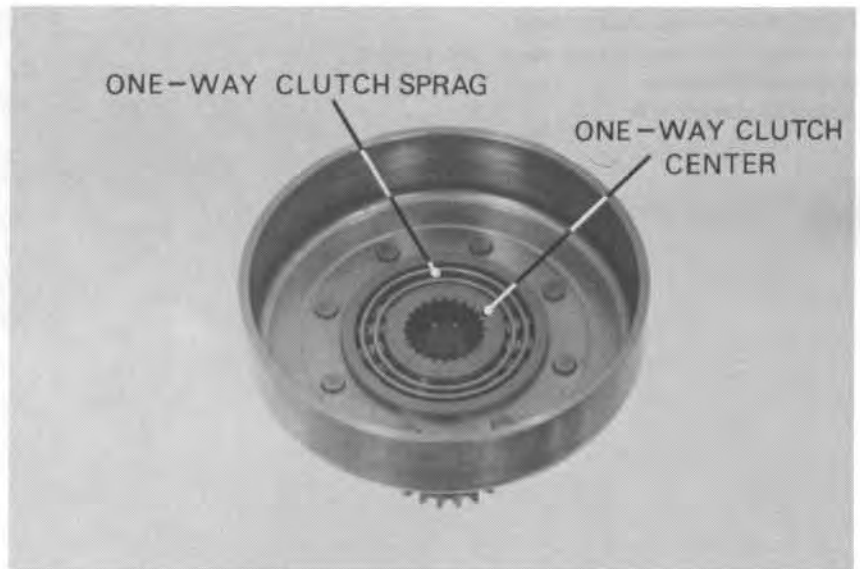

**CLUTCH DRUM INSPECTION**

Check the inside of the centrifugal clutch drum for scratches or excessive wear.

Measure the I. D. of the clutch drum.





**CLUTCH/OIL PUMP**

**CLUTCH INSTALLATION**

Install the clutch centrifugal clutch drum, aligning the clutch outer cutout with the drive gear.

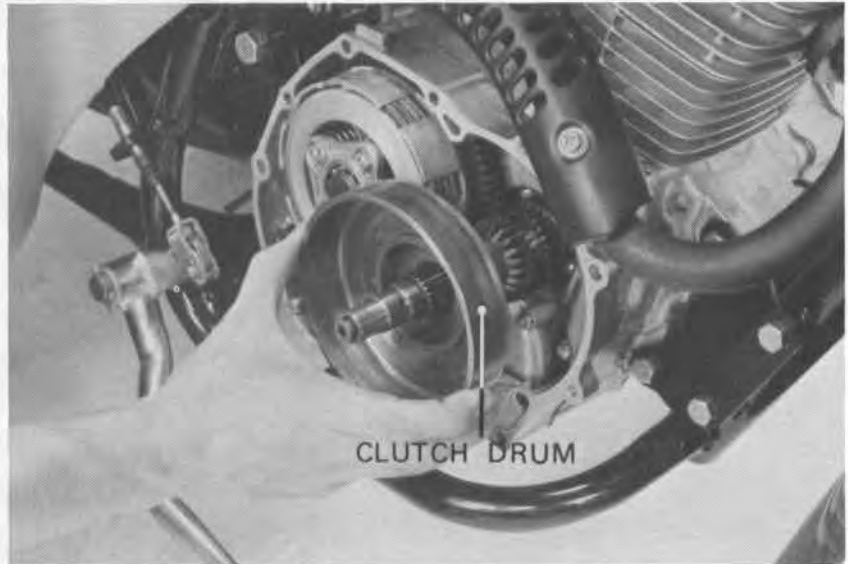

Install the one-way clutch sprag.  
Install the one-way clutch center by turning it counterclockwise.  
Install clutch plate B.

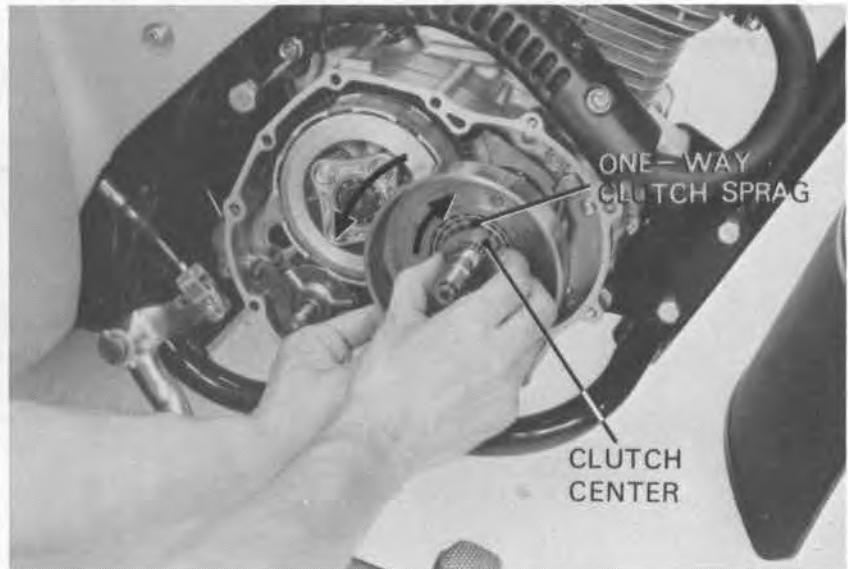

Attach the centrifugal clutch weights to the clutch hub with the links and clips.

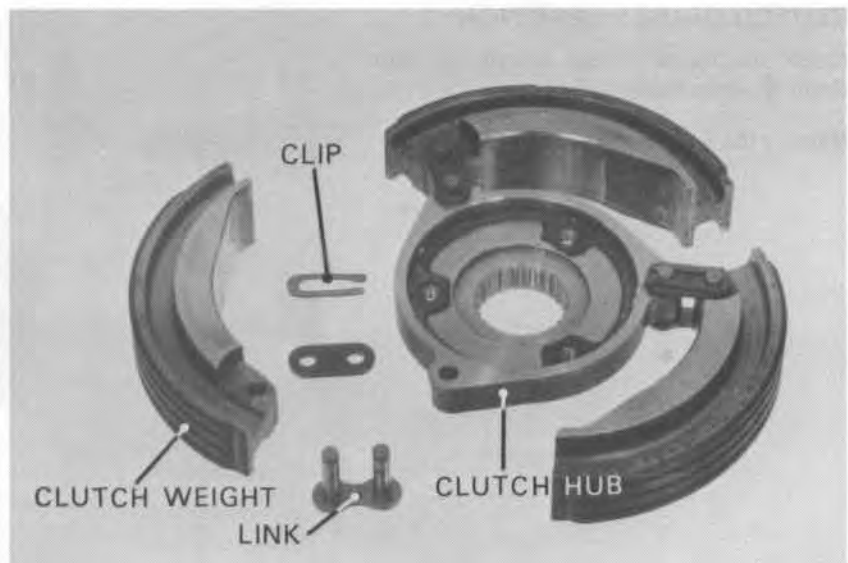





Install the centrifugal clutch springs, using a screwdriver.



Install the centrifugal clutch weight assembly onto the clutch drum.  
Install the lock washer and lock nut.

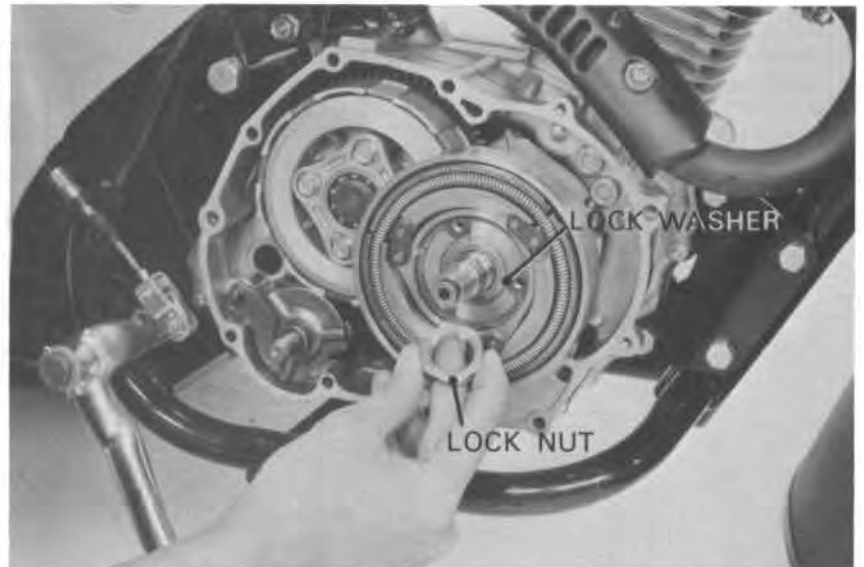

Install the rotor holder or screwdriver (Page 8-5).

Turn the lock nut counterclockwise to tighten it.

**TORQUE: 10.5-11.5 kg-m (76-83 ft-lb)**

**NOTE**

The lock nut has left hand threads.

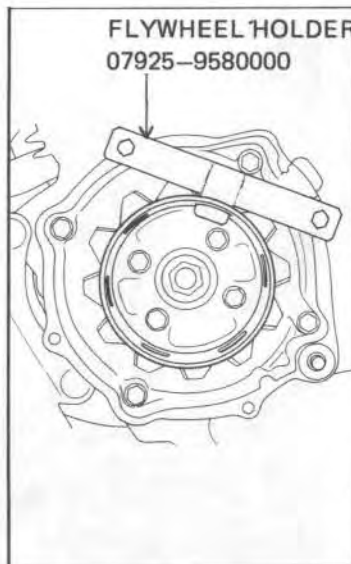



**CLUTCH/OIL PUMP**

Place the oil filter rotor cover gasket onto the clutch hub.

Slip a new O-ring onto the crankshaft. Install the thrust washer, side friction spring and rotor cover.

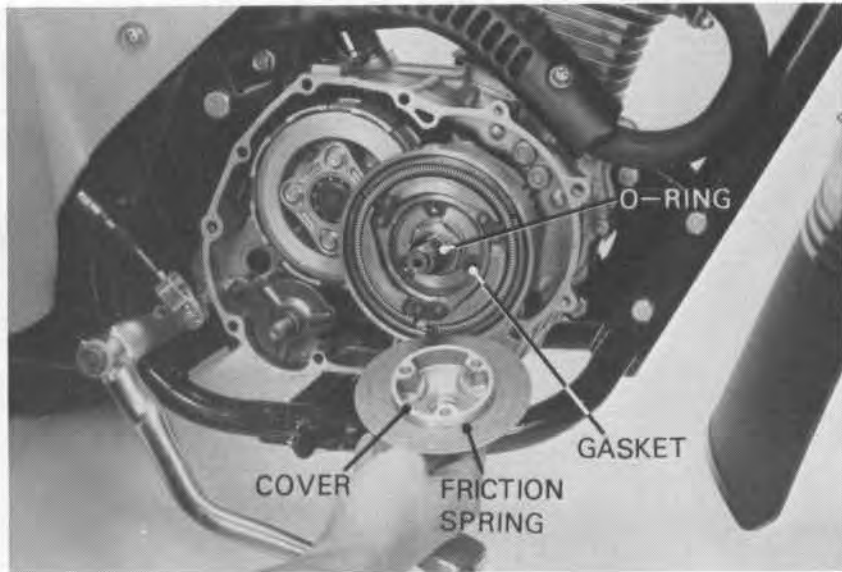

**NOTE**

Align the teeth of the friction spring with the cover groove.

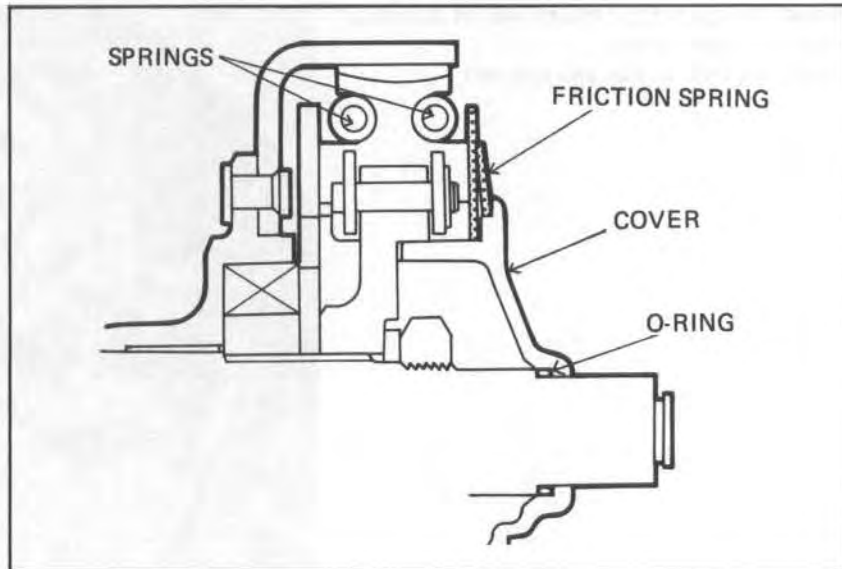

Tighten the cover bolts.

**TORQUE: 1.0-1.4 kg-m (7-10 ft-lb)**

Remove the Rotor Holder.

Install the cooling fan, starter pulley and recoil starter (Page 9-9).

Install the neutral indicator (Page 9-9).

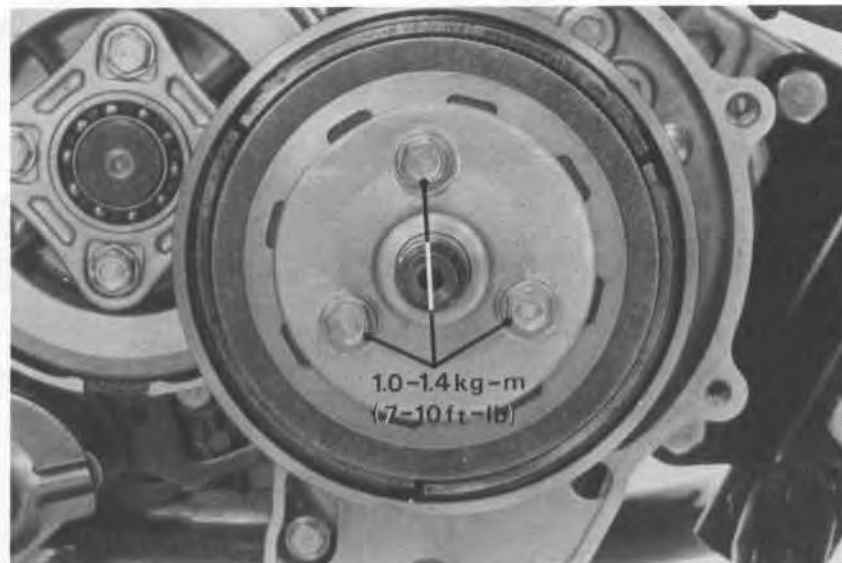



## MANUAL CLUTCH

### CLUTCH REMOVAL

- Remove the clutch cover.
- Remove the centrifugal clutch (Page 8-5).
- Remove the clutch bolts.
- Remove the clutch lifter plate and clutch springs.

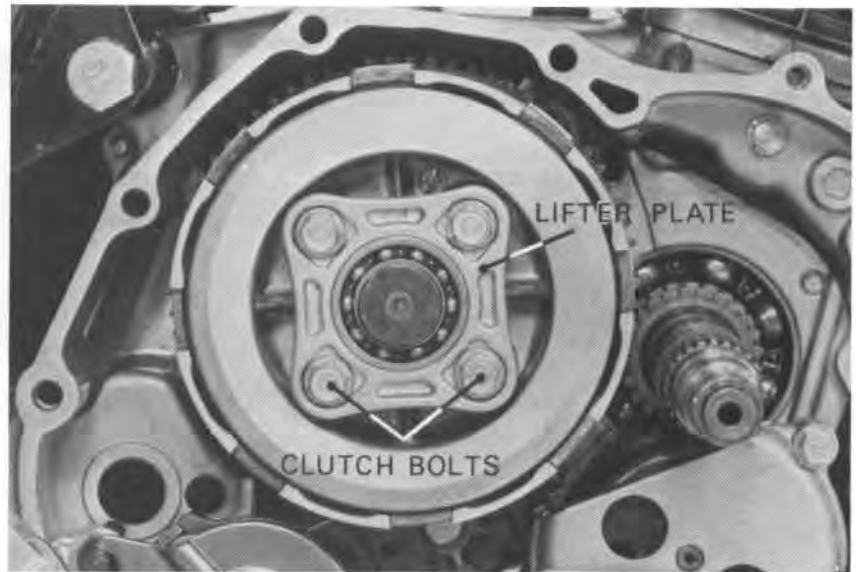

Install a CLUTCH CENTER HOLDER as shown.  
Remove the clutch lock nut.

**LOCK NUT WRENCH**  
20 x 24 mm  
07716-0020100 or  
07916-3710000  
**EXTENSION BAR**

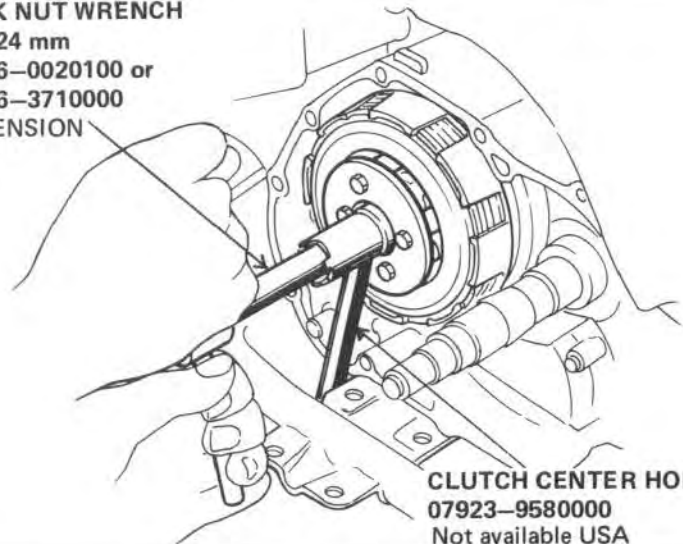

**CLUTCH CENTER HOLDER**  
07923-9580000  
Not available USA

- Remove the clutch center, discs, plates and pressure plate.
- Remove the thrust washer.
- Remove the clutch outer and clutch outer guide.
- Remove the thrust washer.





**CLUTCH/OIL PUMP**

**CLUTCH INSPECTION**

Check the slots of the clutch outer for nicks, cuts or indentations made by the clutch discs. Replace if necessary.

Measure the I. D. of the clutch outer guide.

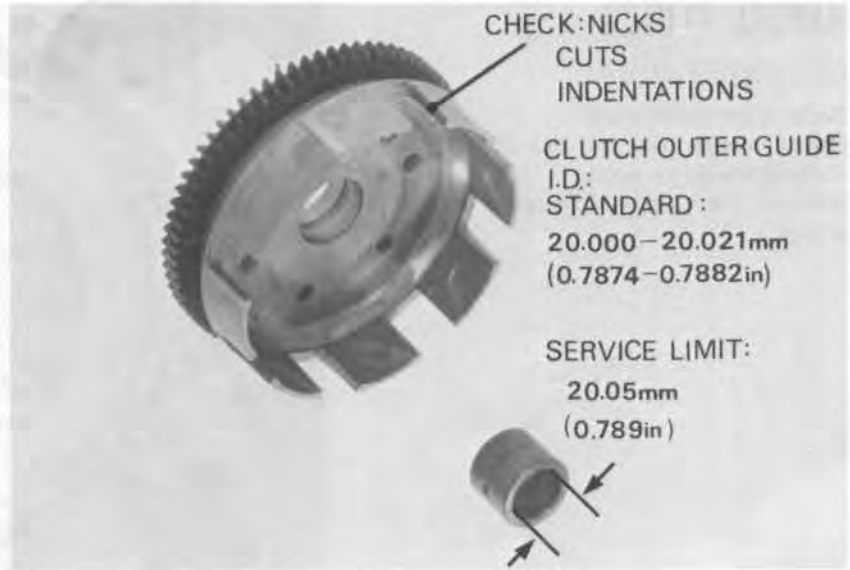

Measure the spring free length.

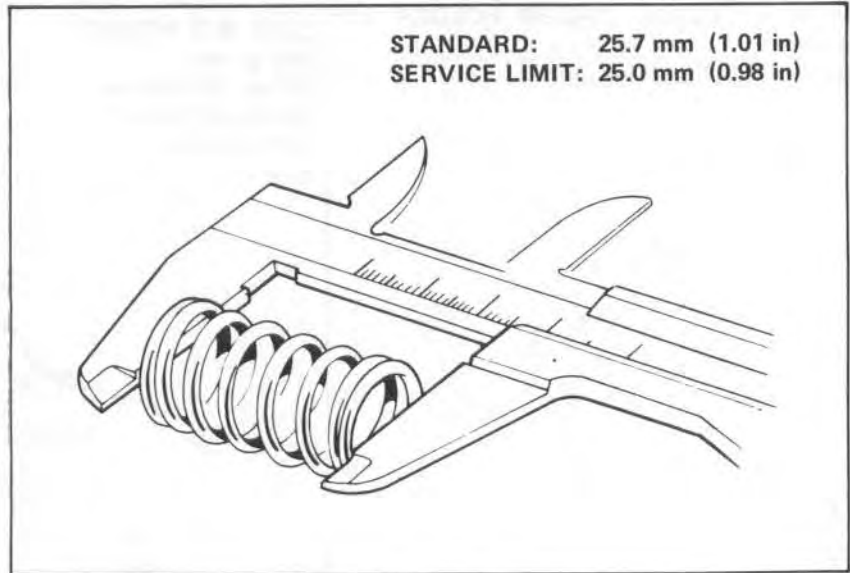

Replace the clutch discs if they show signs of scoring or discoloration.

Measure the disc thickness.

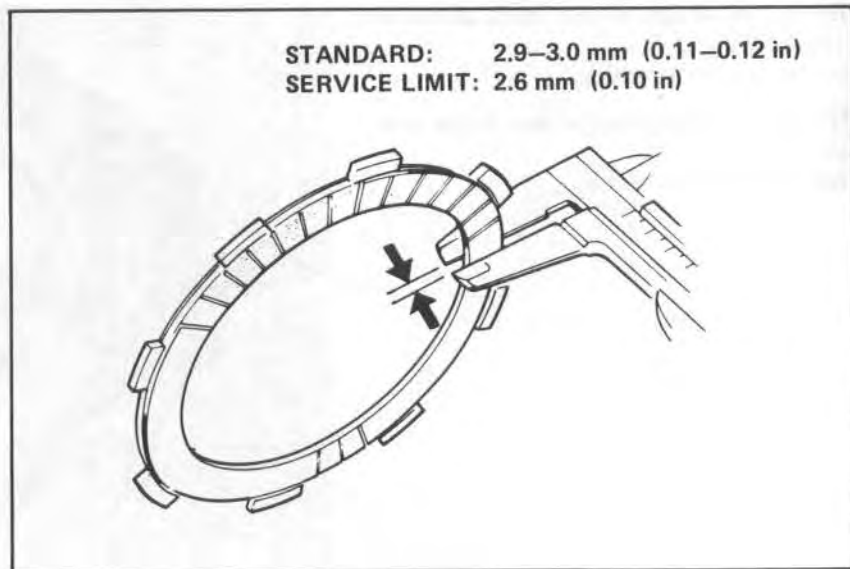



Check for plate and disc warpage on a surface plate using a feeler gauge.

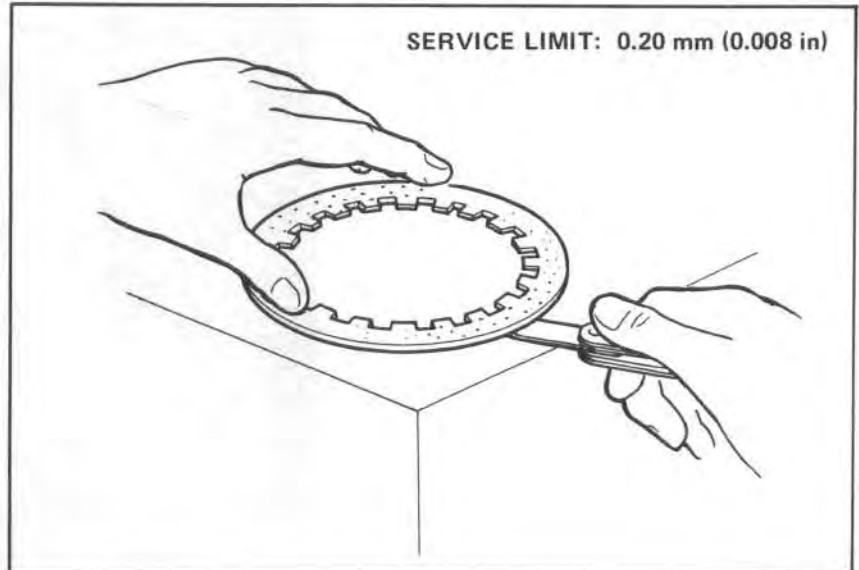

**CLUTCH INSTALLATION**

Assemble the clutch pressure plate, discs, plate and clutch center.

**NOTE**

- Stack the discs and plates alternately.
- Coat new clutch discs with engine oil.

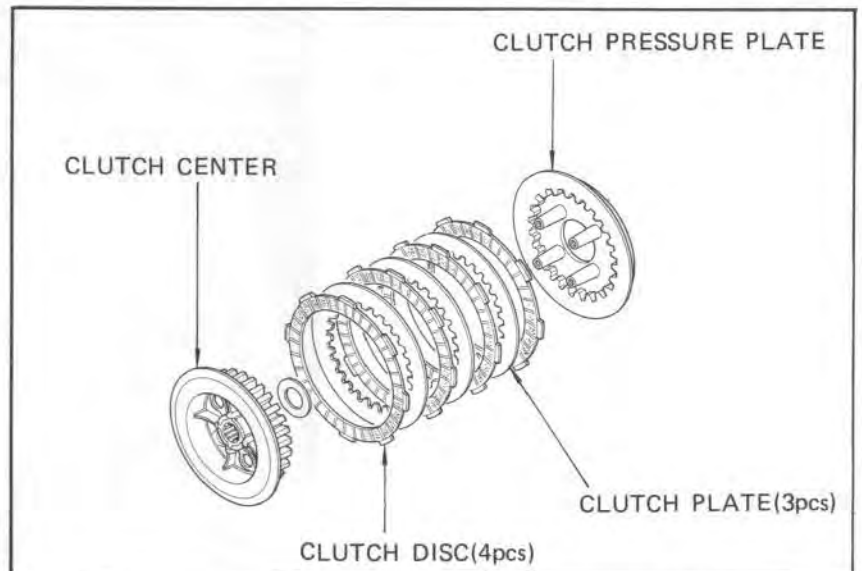

Install the thrust washer.  
Install the clutch outer guide.  
Install the clutch outer.





**CLUTCH/OIL PUMP**

Install the thrust washer.  
Install the clutch assembly.



Install the lock washer with the STAMPED WORD "OUTSIDE" facing out.

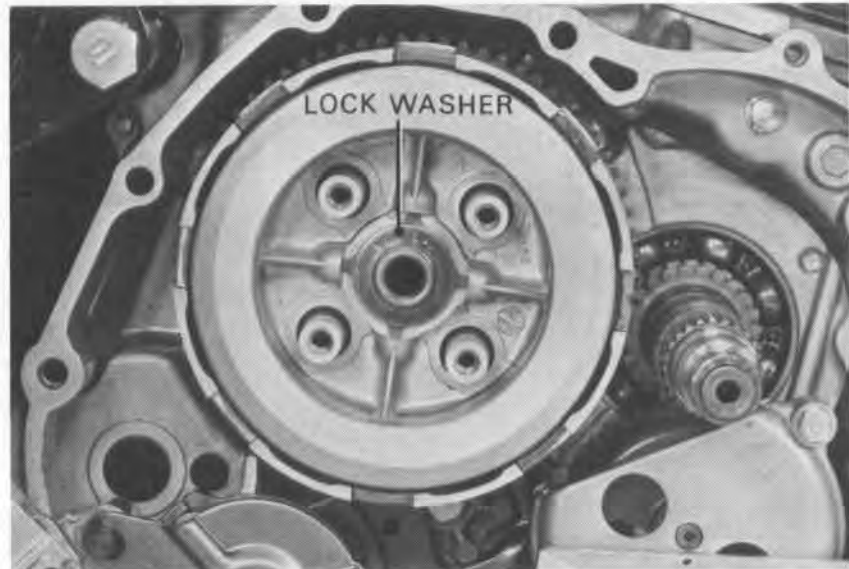

Install the clutch center holder with clutch bolts.

Tighten the lock nut.

**TORQUE: 5.0-6.0kg-m (36-43 ft-lb)**

Install the clutch spring and lifter plate.  
Tighten the clutch bolts.

Install the bearing and push rod.  
Install the centrifugal clutch (Page 8-8).

**LOCK NUT WRENCH**  
20 x 24 mm  
07716-0020100 or  
07916-3710000  
**EXTENSION BAR**

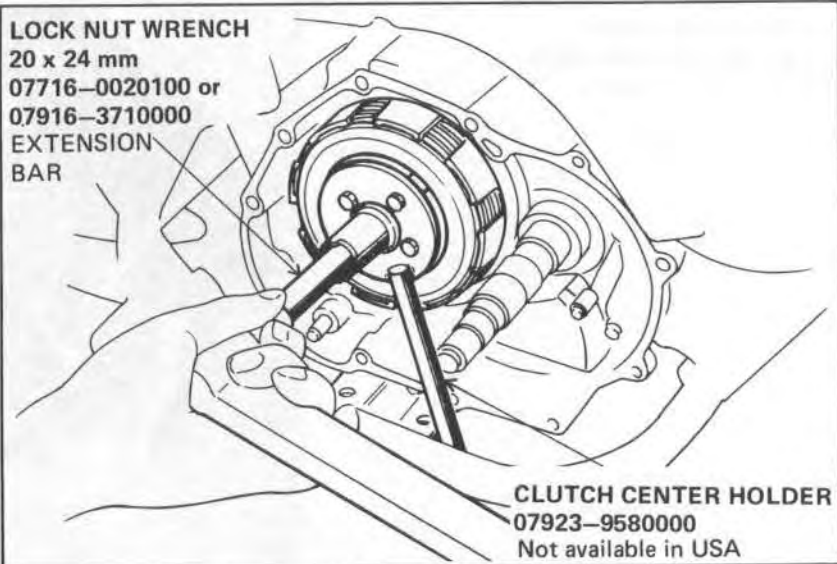



## OIL PUMP

### OIL PUMP REMOVAL

Remove the centrifugal clutch (Page 8-5).  
Remove the clutch (Page 8-11).

Remove the clutch lifter cam, ball retainer  
and clutch lifter (Page 8-18).

Remove the right crankcase cover (Page 8-18).

Align the oil pump setting screws with the  
gear cover holes.

Remove the oil pump setting screws.

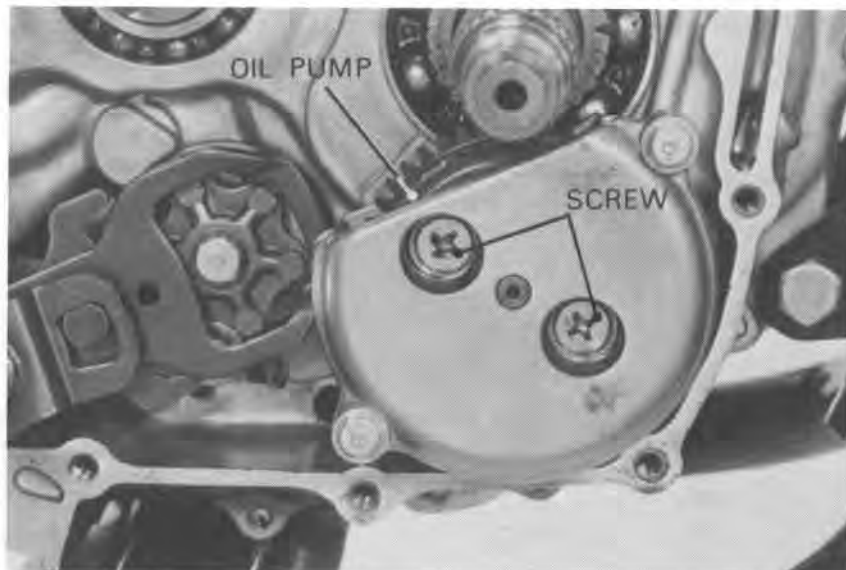

### OIL PUMP DISASSEMBLY

Remove the oil pump cover and gasket.  
Remove the oil pump inner and outer rotors.

Remove the bolts and pump gear cover.  
Remove the pump driven gear.

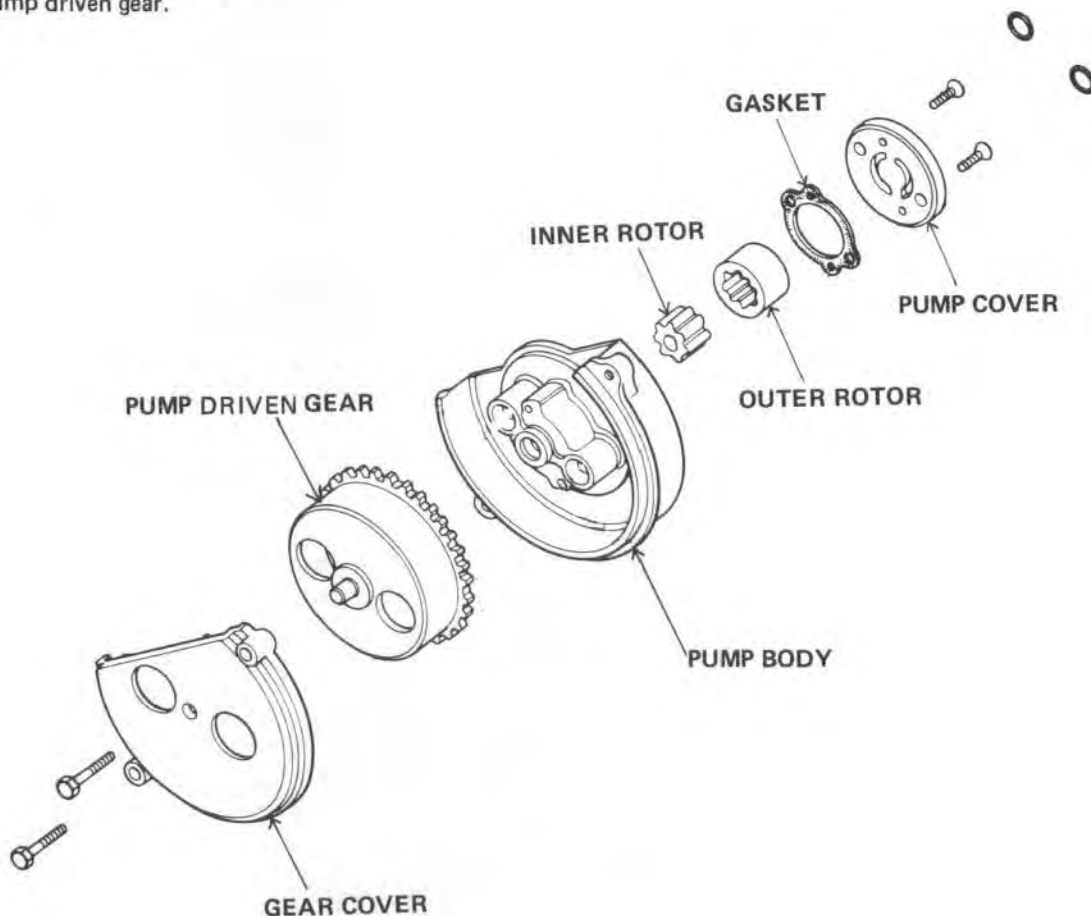



**CLUTCH/OIL PUMP**

**OIL PUMP INSPECTION**

Measure the pump body clearance.

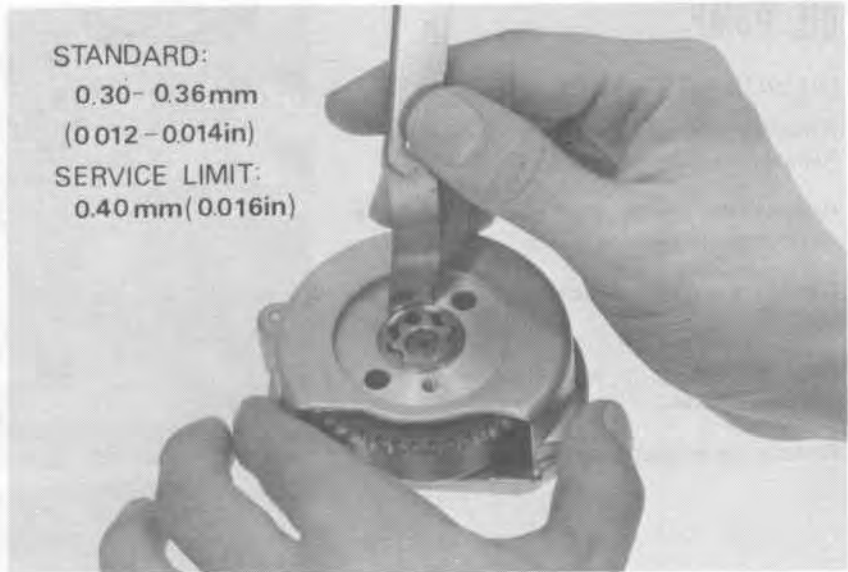

Measure the pump tip clearance.



**OIL PUMP ASSEMBLY**

Install the pump gear and gear cover onto the oil pump body.

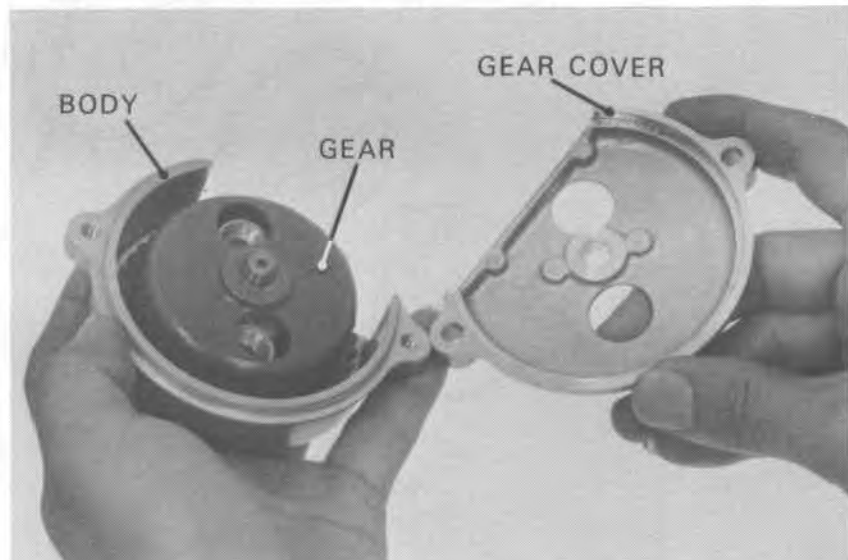





Install the inner and outer rotors.  
Install the gasket.

Install the pump cover by aligning the cover center with the gear shaft.

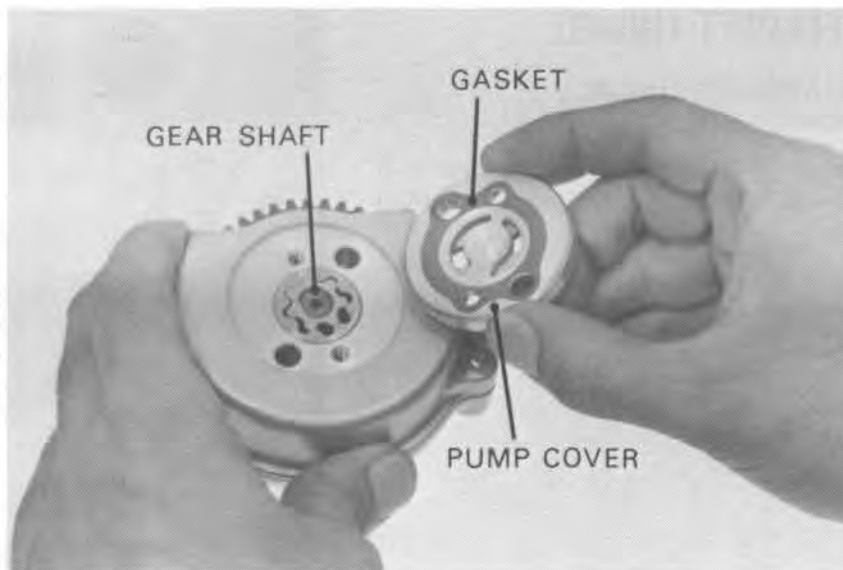

Tighten the screws.

Check operation of the pump by rotating the pump gear by hand.

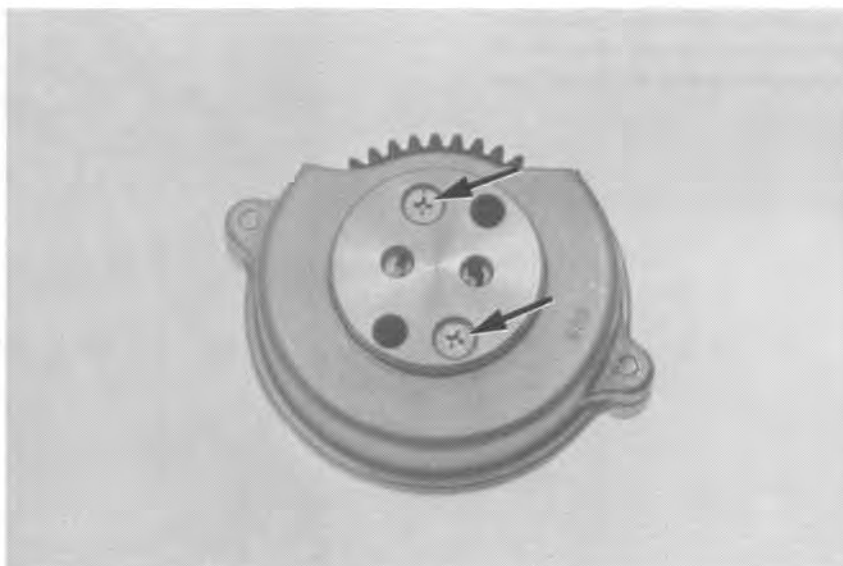

### OIL PUMP INSTALLATION

Install the O-rings.  
Install the pump.

#### NOTE

Make sure that the O-rings remain in place when installing the pump.

Install the oil pump assembly.





## GEARSHIFT LINKAGE

### GEARSHIFT LINKAGE DISASSEMBLY

Remove the right crankcase cover (Page 8-3).  
Remove the manual clutch and centrifugal clutch.

Remove the clutch lifter cam.  
Remove the ball retainer and clutch lifter.

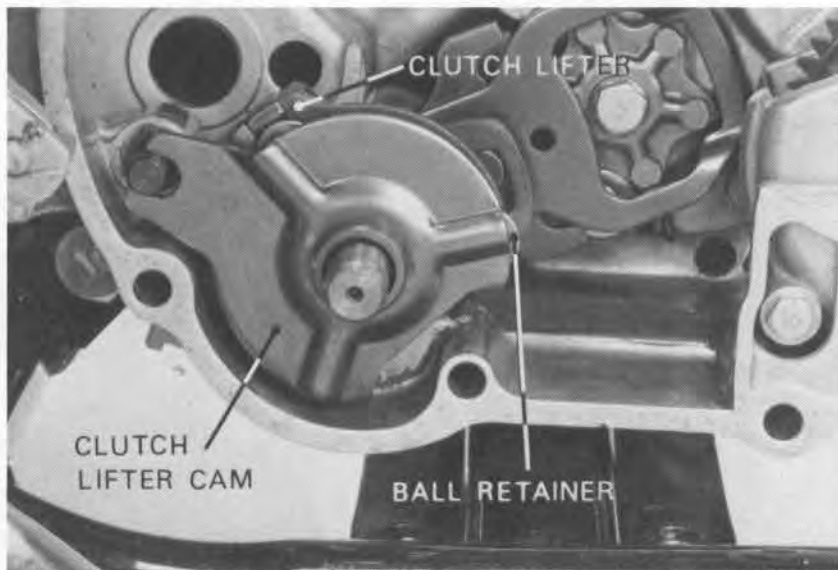

Remove the right crankcase spacer.  
Remove the oil pump (Page 8-15).  
Remove the gasket and dowel pins.

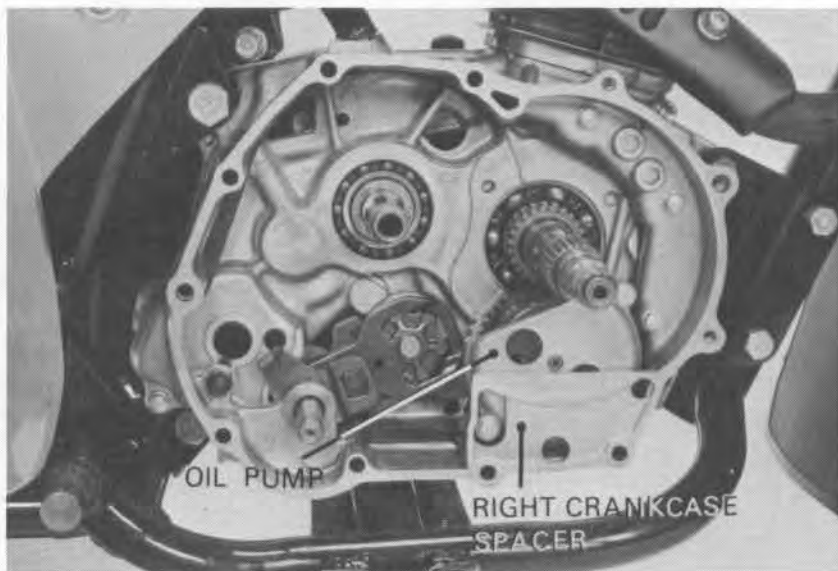

Remove the gearshift pedal.  
Pull the gearshift spindle out.

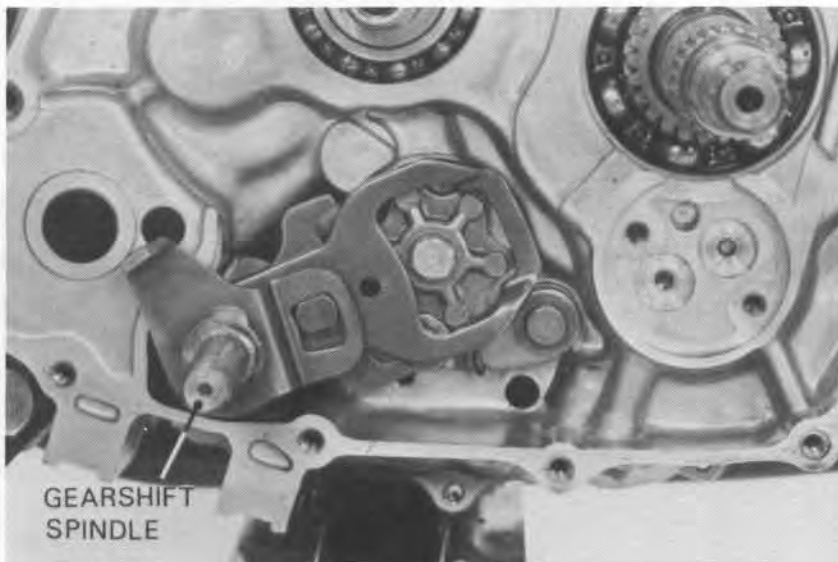



Remove the thrust washer.  
Remove the circlip and disassemble the gearshift spindle.

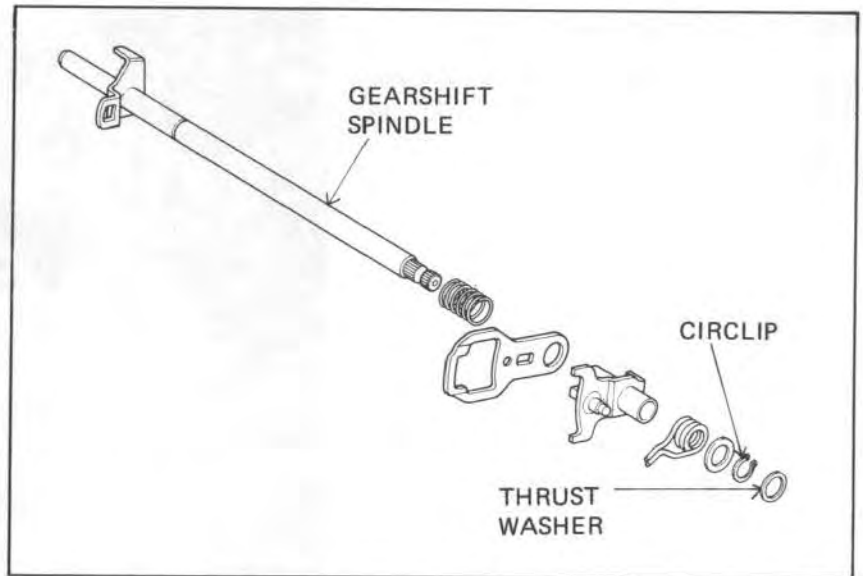

Remove the drum stopper plate.  
Remove the drum stopper arm.

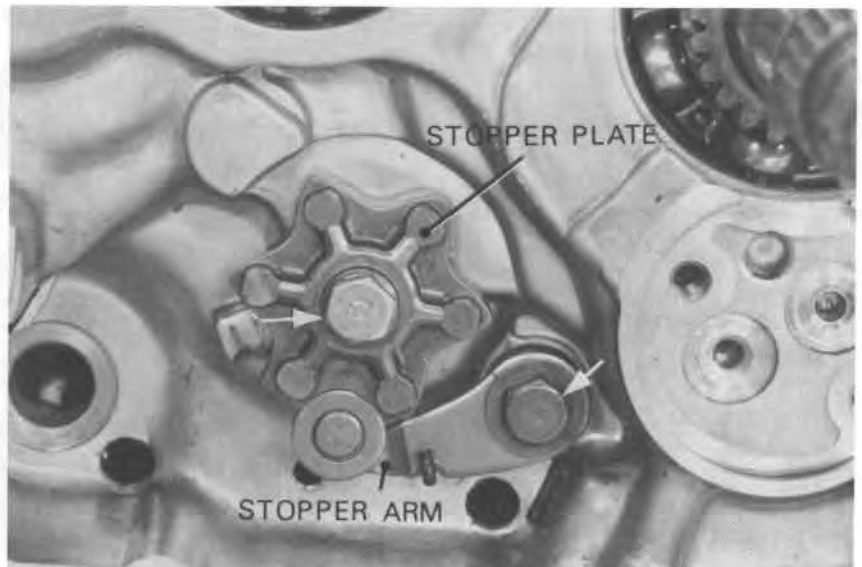

**GEARSHIFT LINKAGE ASSEMBLY**

Install the drum stopper plate by aligning the hole and dowel pin.

Install the stopper arm.

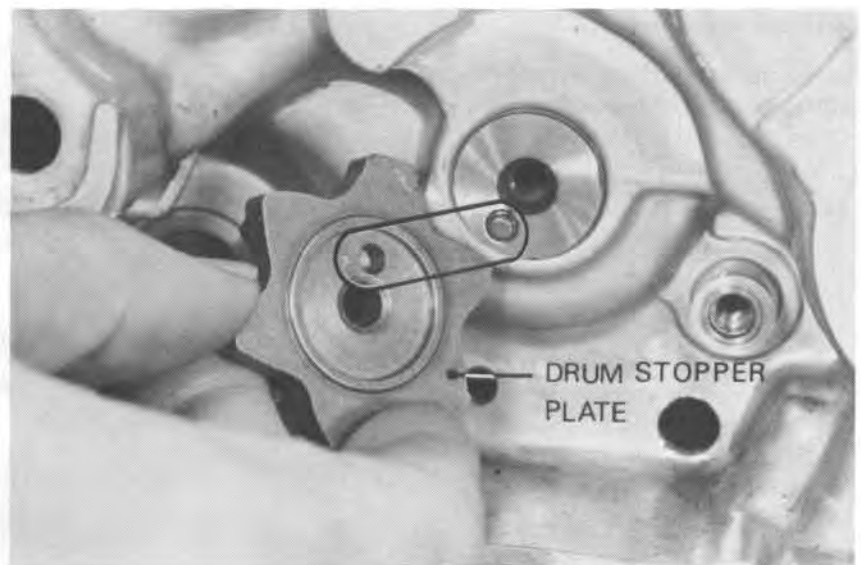



**CLUTCH/OIL PUMP**

Assemble the gearshift spindle.

Install the gearshift spindle assembly and gearshift pedal.

Install the oil pump (Page 8-17).

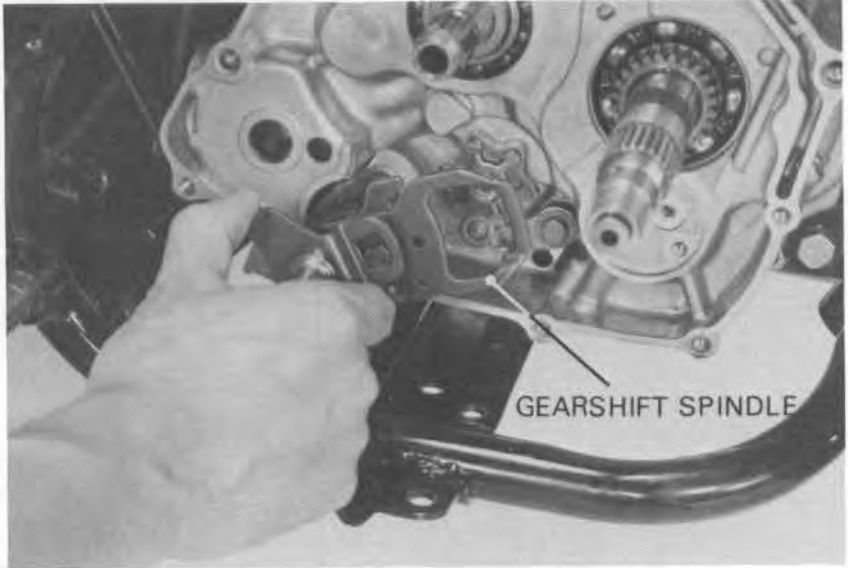

Install the dowel pins and gasket.  
Install the right crankcase spacer.

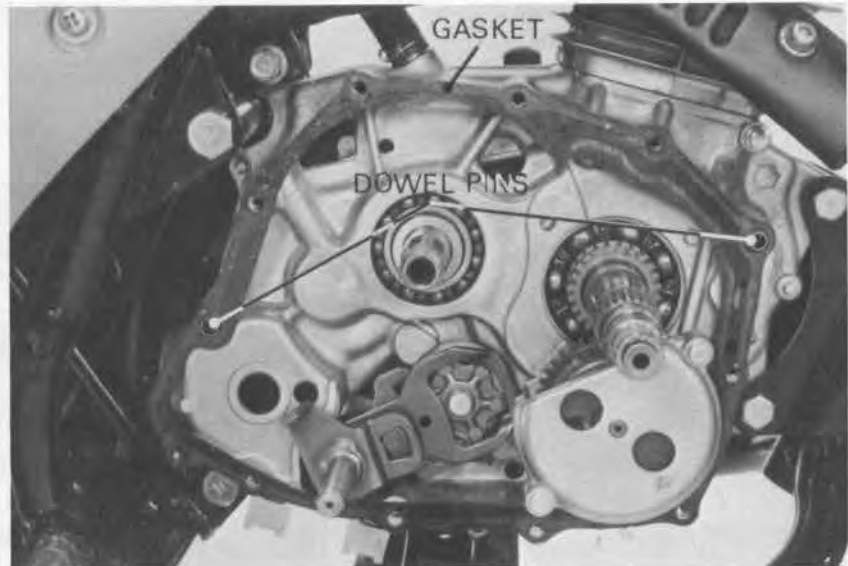

Install the thrust washer.

Install the clutch lifter by aligning the boss with the cut-out of the clutch lifter.

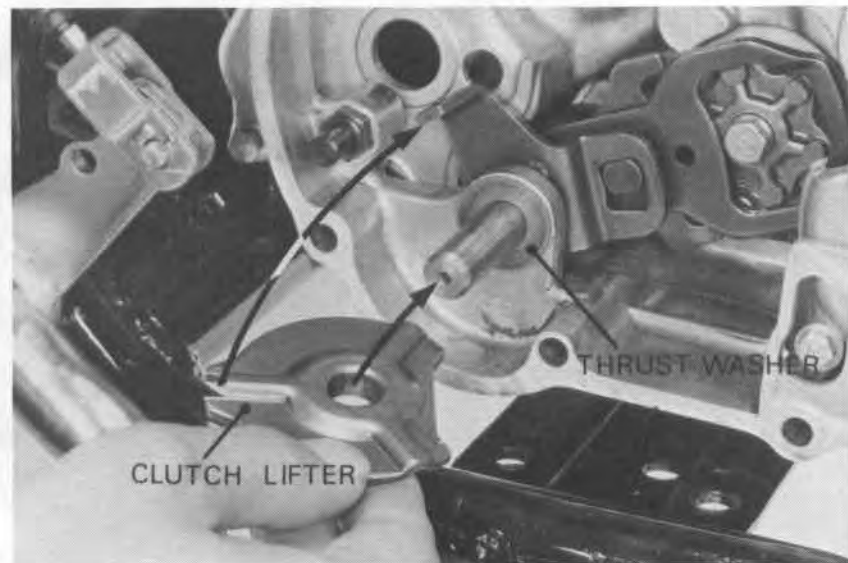



Install the ball retainer.  
Install the clutch lifter cam by aligning the cut-out of the cam with the lifter cam stopper bolt on the crankcase spacer.

Install the manual clutch (Page 8-13).  
Install the centrifugal clutch (Page 8-8).

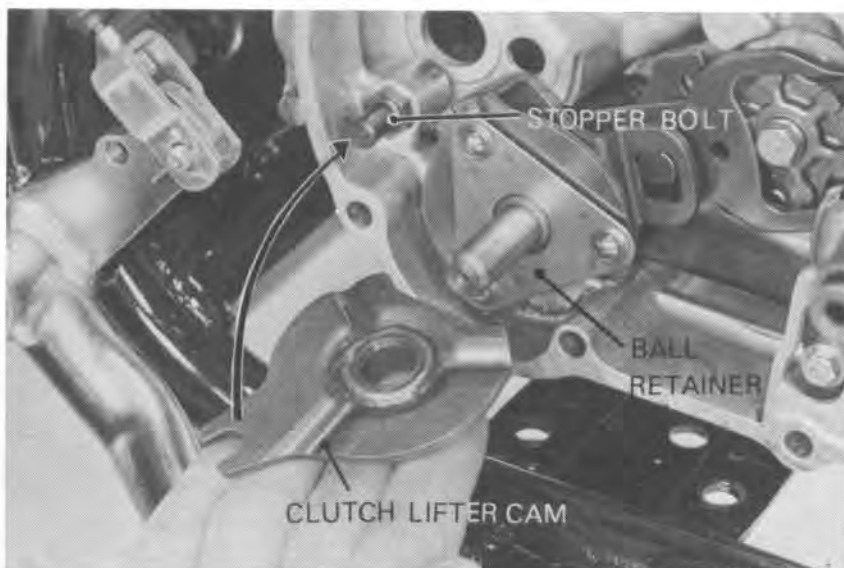

## **RIGHT CRANKCASE COVER INSTALLATION**

Install the dowel pins and gasket.  
Install the right crankcase cover.  
Install the foot peg.

Adjust the clutch (Page 3-13).  
Fill the engine with the recommended oil (Page 2-2).

Connect the rear brake cable and install the brake pedal return spring.  
Adjust the rear brake pedal (Page 3-12).

Start the engine and check the clutch for smooth operation.

Be sure there are no oil leaks.

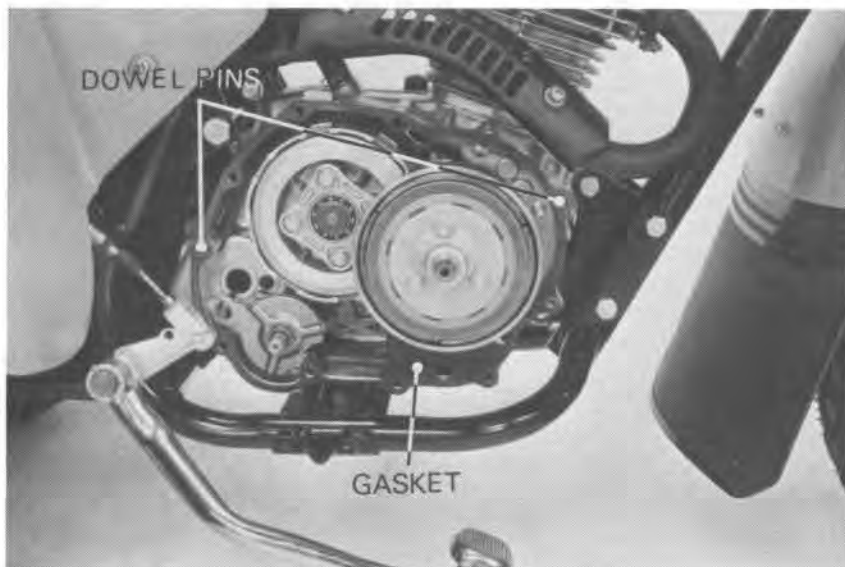

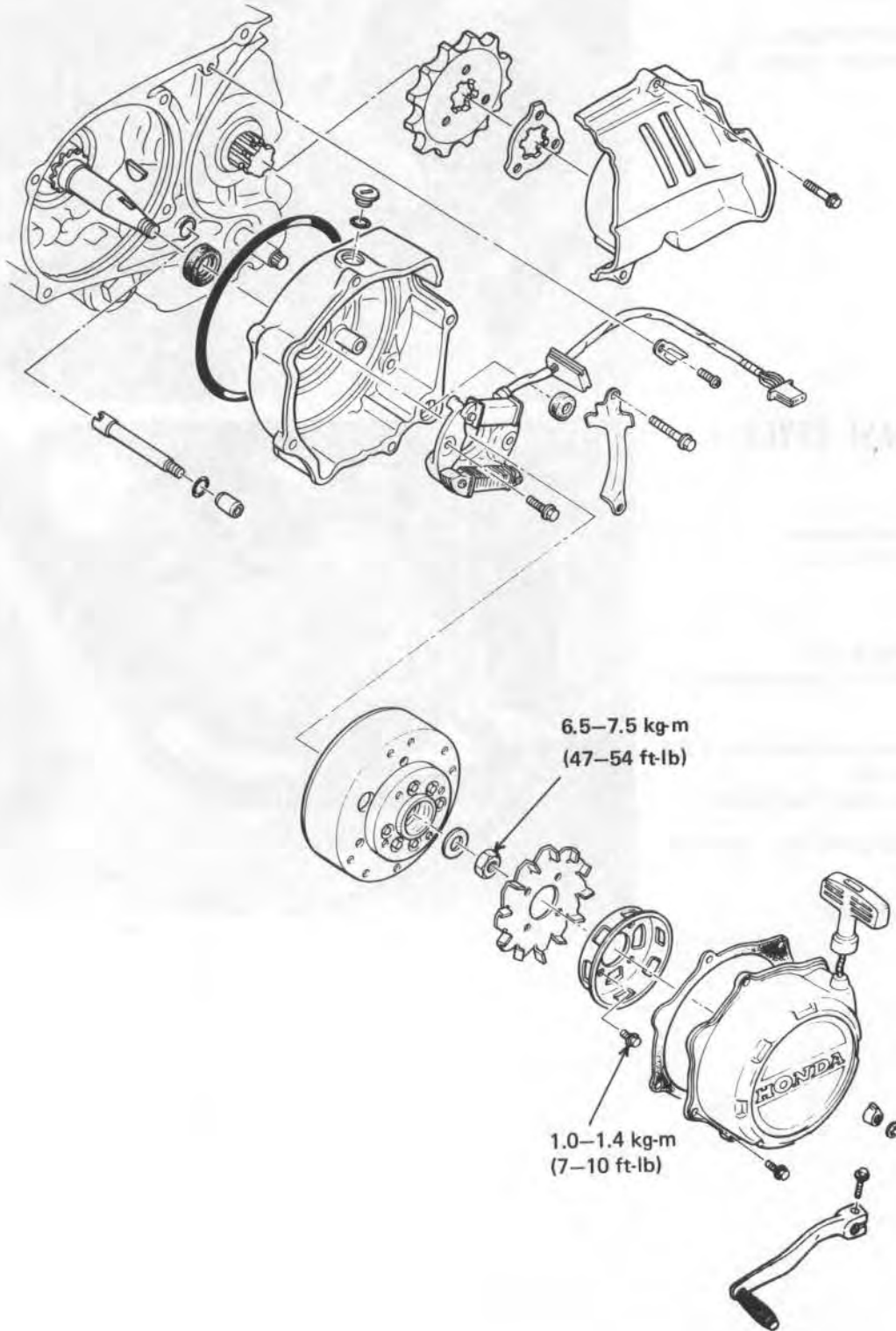



SERVICE INFORMATION	9-1
TROUBLESHOOTING	9-1
RECOIL STARTER REMOVAL	9-2
RECOIL STARTER DISASSEMBLY	9-2
RECOIL STARTER ASSEMBLY	9-4
A. C. GENERATOR REMOVAL	9-6
A. C. GENERATOR INSTALLATION	9-7
RECOIL STARTER INSTALLATION	9-9

**SERVICE INFORMATION**

**GENERAL INSTRUCTIONS**

- This section covers removal and installation of the recoil starter and A. C. generator.
- For A. C. generator inspection and troubleshooting, refer to section 14.

**TOOLS**

Common Flywheel and Rotor Puller	07733-0010000 or 07933-0010000
Special Flywheel Holder	07925-9580000 Not available in USA

**TORQUE VALUES**

A. C. generator rotor nut	6.5-7.5 kg-m (47-54 ft-lb)
Recoil starter driven pulley bolt	1.0-1.4 kg-m ( 7 -10 ft-lb)

**TROUBLESHOOTING**

**Engine does not turn when operating  
recoil starter**

1. Faulty starter ratchet
2. Faulty starter driven pulley
3. Faulty starter drive pulley

**Starter rope does not recoil**

1. Faulty recoil spring



## RECOIL STARTER REMOVAL

Shift the transmission into the neutral.  
Remove the gearshift pedal.

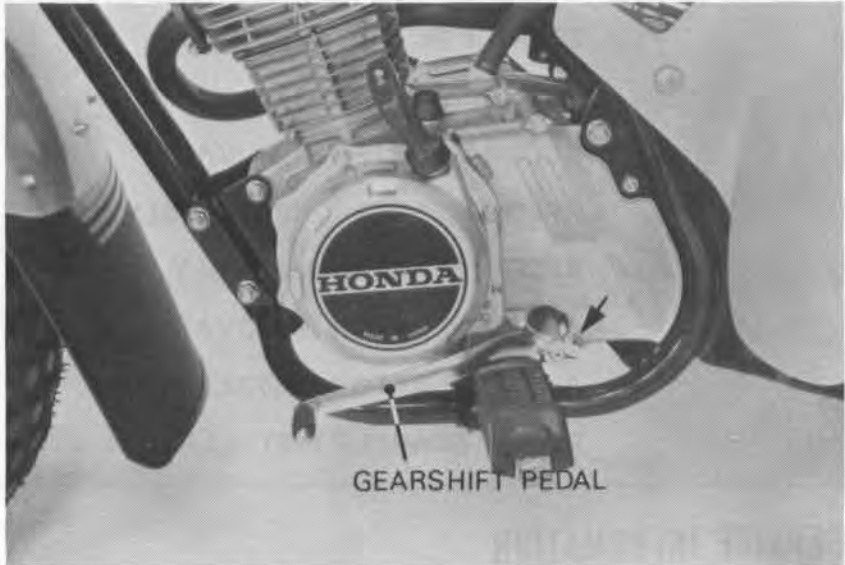

Remove the neutral indicator.  
Remove the recoil starter bolts.

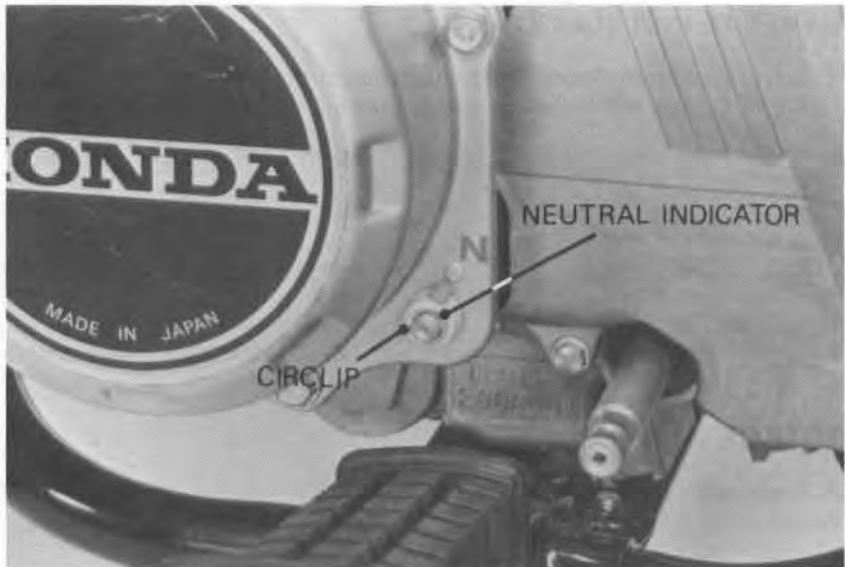

## RECOIL STARTER DISASSEMBLY

Remove the circlip.  
Remove the thrust washer and ratchet cover.

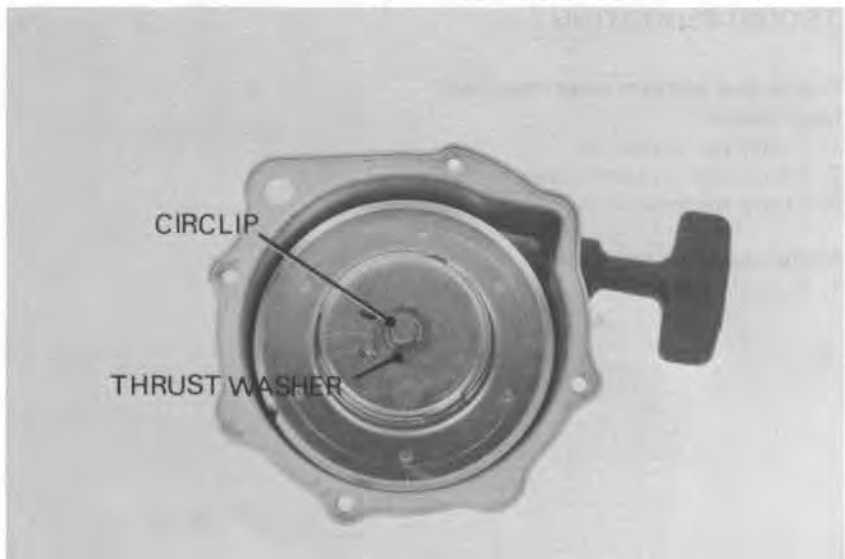





Remove the ratchets and ratchet springs.  
Remove the spring and thrust washer.

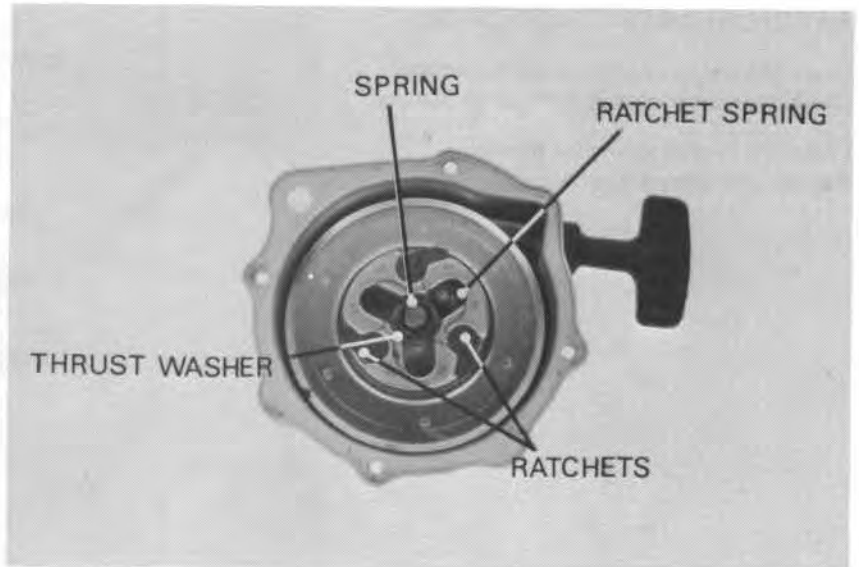

Remove the starter grip.  
Release the starter rope slowly.

Remove the starter drive pulley by turning  
the pulley counterclockwise.

**CAUTION:**

*Wear eye protection and use care  
when removing the drive pulley and  
starter spring. The spring can pop  
out of the housing if care is not used.*

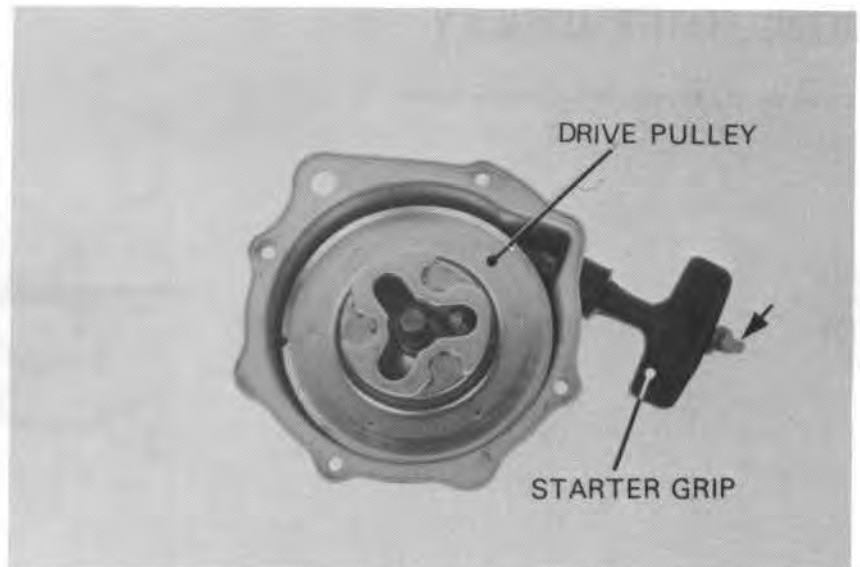

Check the recoil starter spring.  
Remove the starter spring, if necessary.

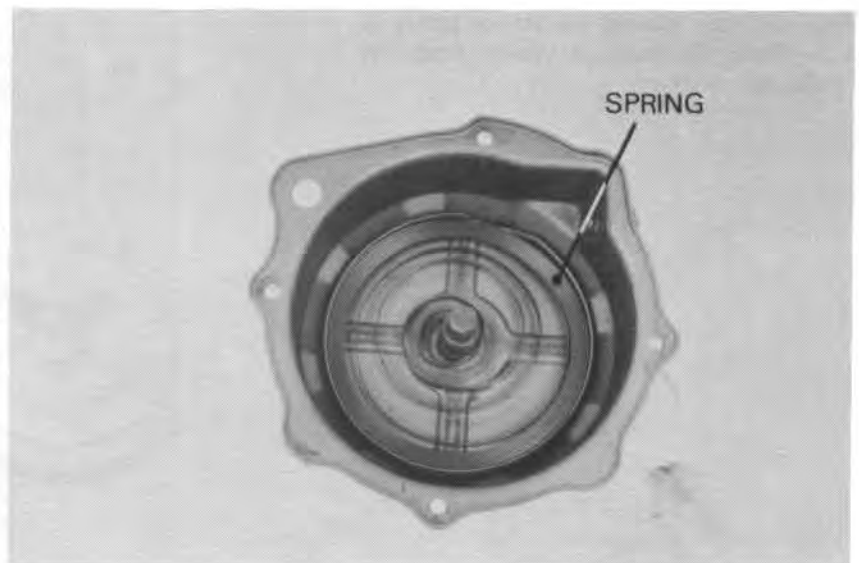



**STARTER/A. C. GENERATOR**

**RECOIL STARTER INSPECTION**

Check the starter rope for wear or damage.  
Check the starter ratchet for wear or damage.  
Check the ratchet spring for damage.  
Replace any damaged parts.

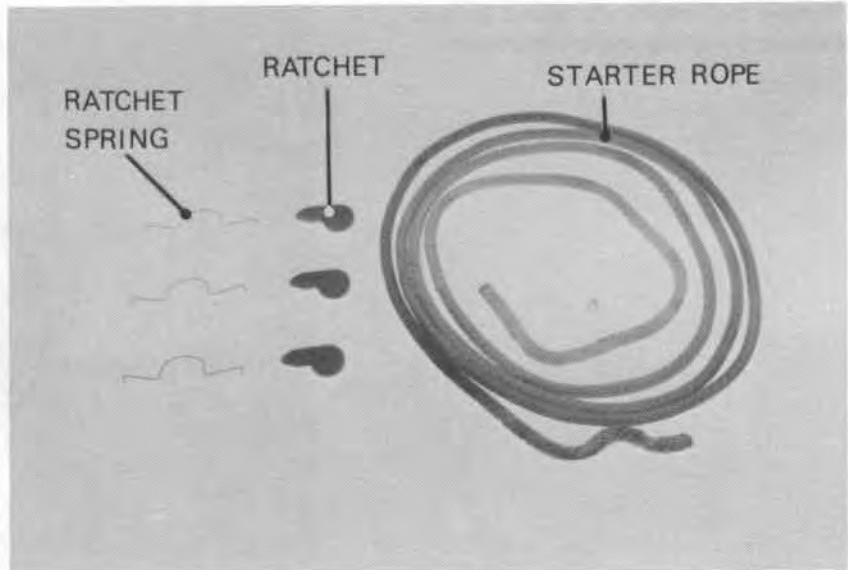

**RECOIL STARTER ASSEMBLY**

Install the starter rope and a knot as shown.

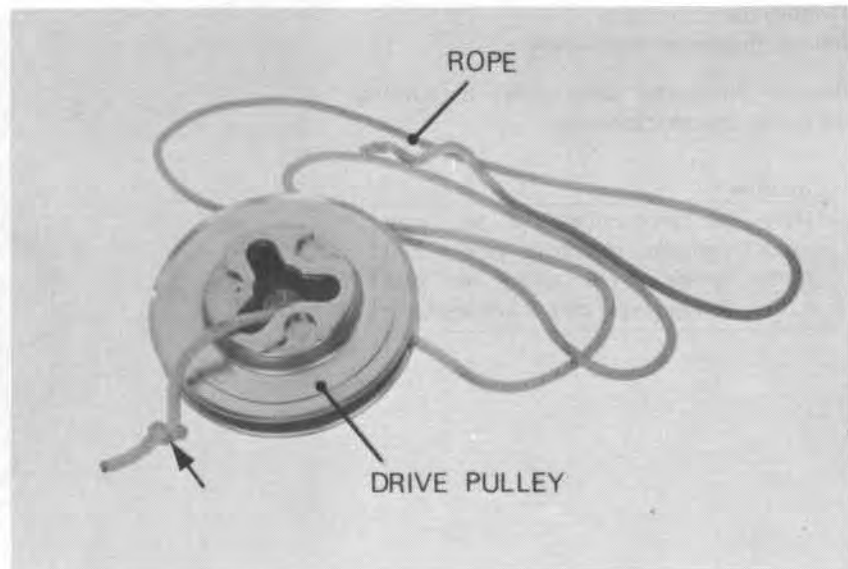

Wrap the rope around the starter pulley in a clockwise direction as viewed from the ratchet side as shown.

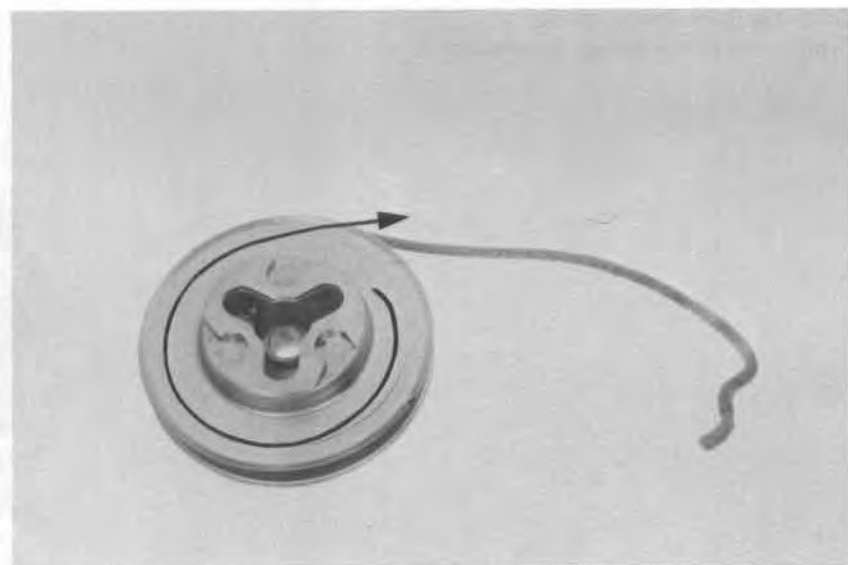



Apply grease to the pulley shaft.  
Install the spring by hooking the end with the starter housing hook.

**CAUTION:**

*Wear eye protection and use care when removing the drive pulley and starter spring. The spring can pop out of the housing if care is not used.*

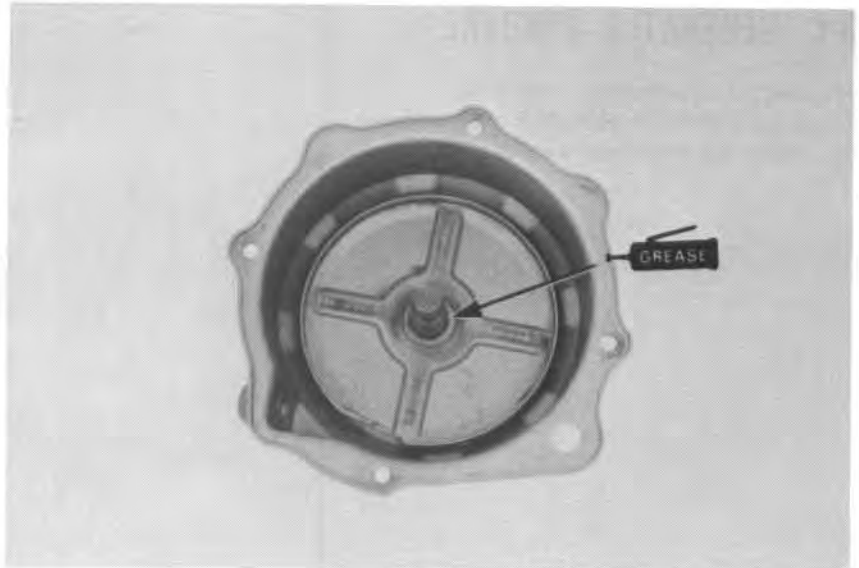

Install the starter pulley by turning it clockwise to align the spring end with the starter pulley boss.

Route the starter rope through the pulley cut-out.

Preload the starter spring by turning the pulley 2 turns counterclockwise.

Route the rope end through the starter housing hole and install the grip.

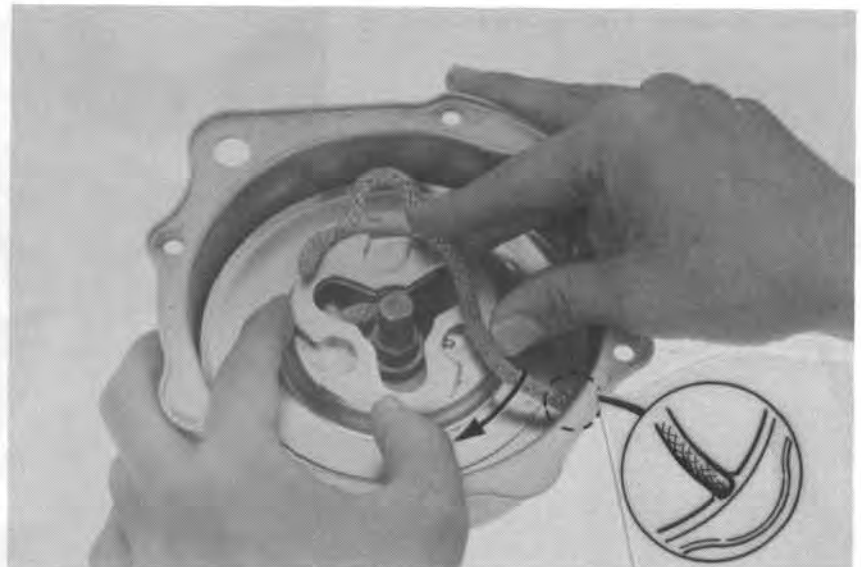

Apply grease to the ratchets.  
Install the ratchets and ratchet springs.

Coat the thrust washer with grease and install it.

Install the spring.  
Install the ratchet cover, thrust washer and circlip.

Check recoil starter operation by pulling the starter grip.

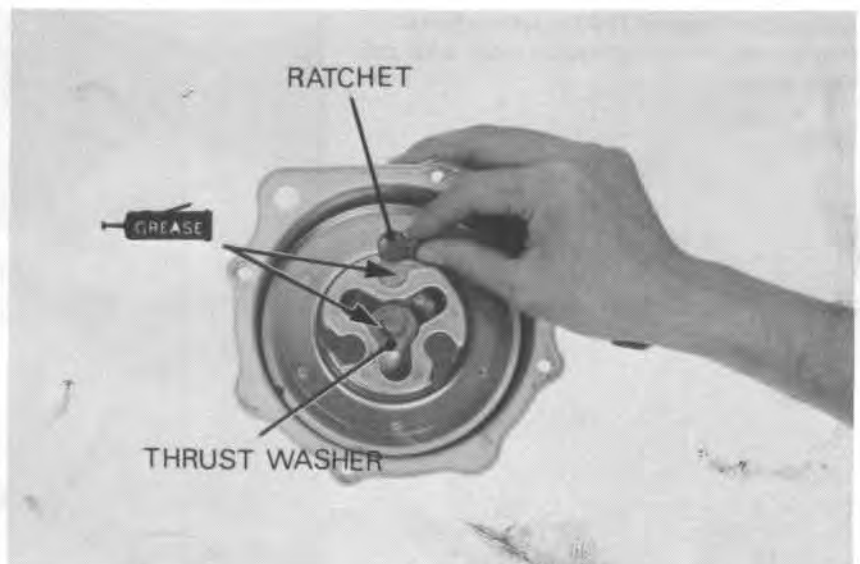



**STARTER/A. C. GENERATOR**

**A.C. GENERATOR REMOVAL**

Remove the recoil starter (Page 9-2).  
Install a FLYWHEEL HOLDER or screwdriver  
to prevent the rotor from turning.

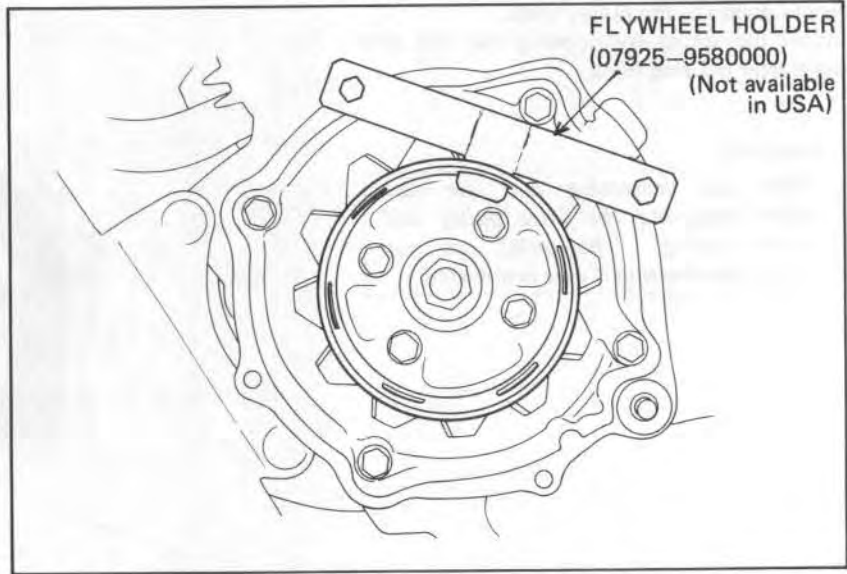

Remove the starter driven pulley and cooling fan.

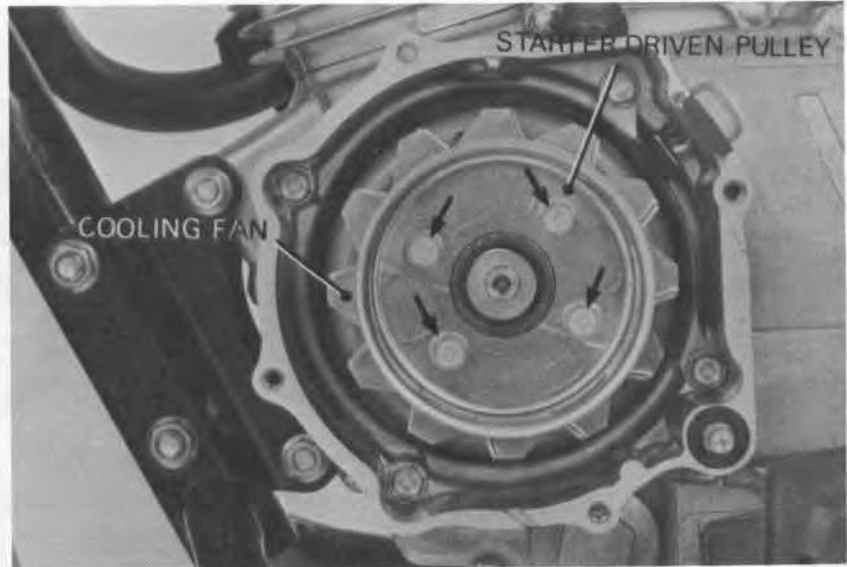

Loosen the Flywheel Holder setting bolts.  
Remove the A. C. generator rotor with the  
rotor puller.





Remove the drive sprocket cover.  
Disconnect the A. C. generator coupler.  
Remove the generator wire clamp.

Drain the engine oil.  
Remove the A. C. generator housing.  
Remove the stator coils from the generator housing.

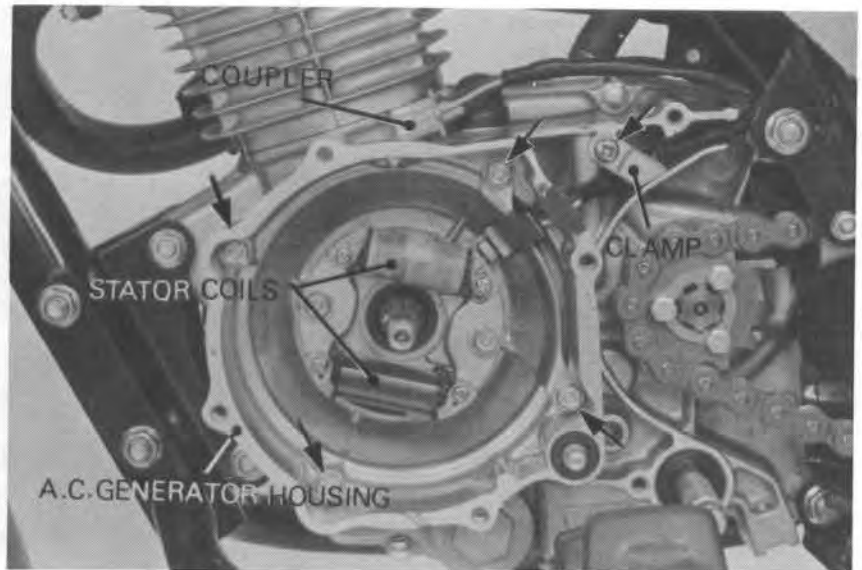

### A.C. GENERATOR INSTALLATION

Install the A. C. generator stator coil onto the generator housing as shown.

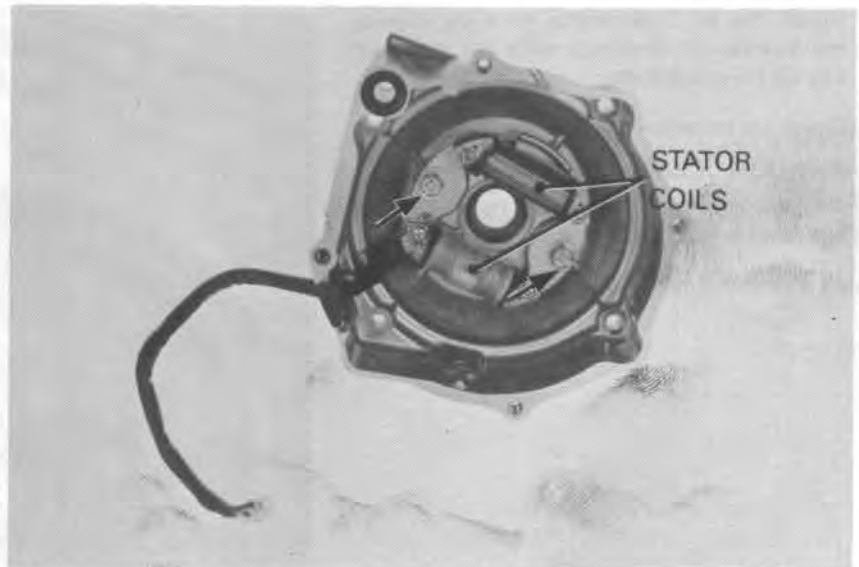

Install the dowel pin and O-rings.  
Install the neutral indicator shaft.

Install the A. C. generator housing by aligning the neutral indicator shaft groove with the gearshift drum cut-out.

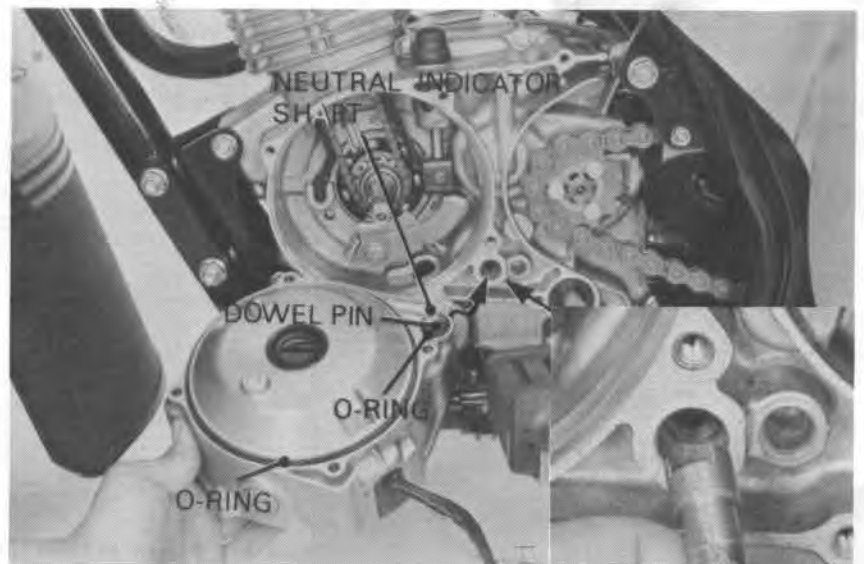



**STARTER/A. C. GENERATOR**

Install the generator wire holder.  
Install the generator wire clamp.

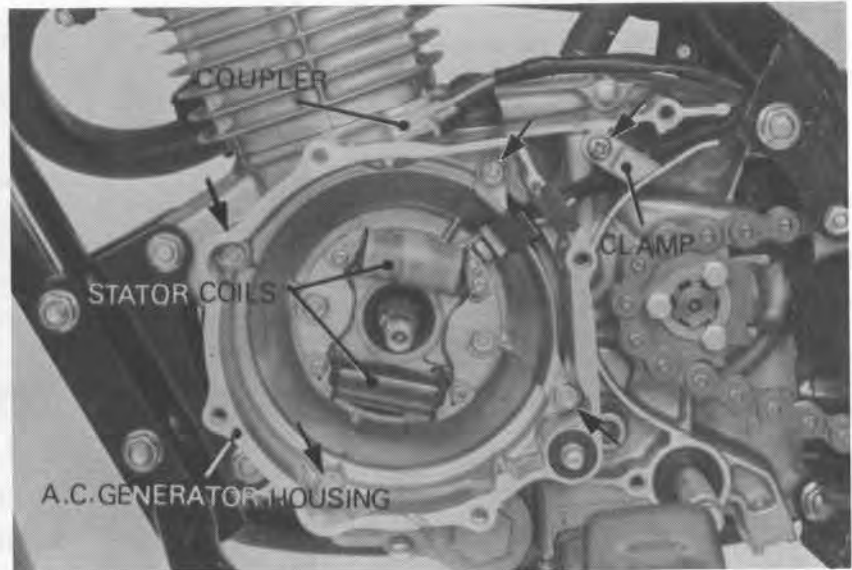

Install the A. C. generator rotor by aligning the keyway of the rotor with the woodruff key on the crankshaft.

Check for rotor-to-wire holder clearance.

**MINIMUM CLEARANCE: 1 mm (0.04 in)**

Replace or repair the wire holder, if the clearance is less than 1 mm (0.04 in).

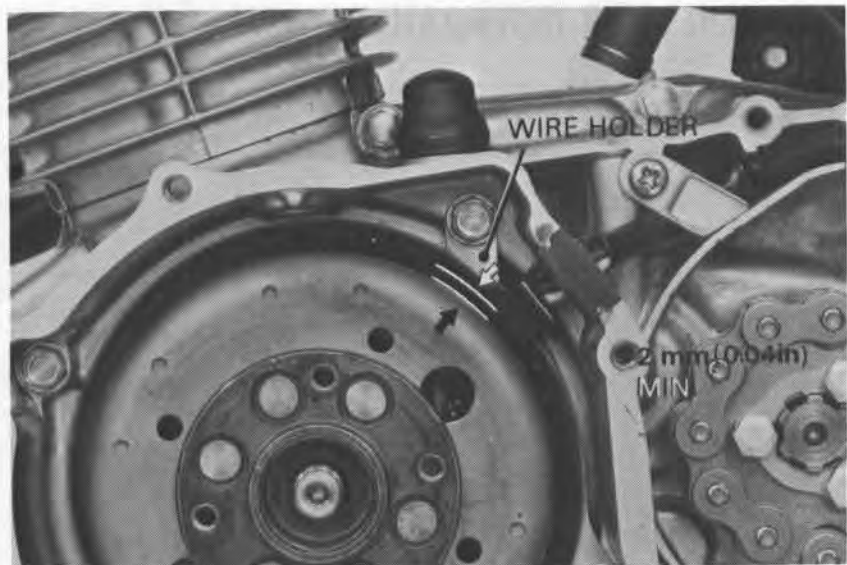

Install the starter driven pulley and cooling fan.

**TORQUE: 1.0–1.4 kg-m (7–10 ft-lb)**

Tighten the rotor nut.

**TORQUE: 6.5–7.5 kg-m (47–54 ft-lb)**

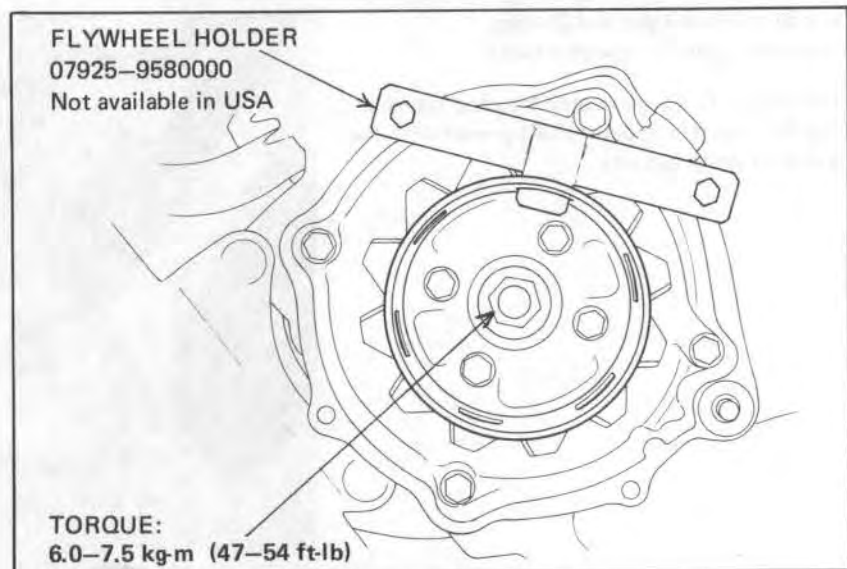



## RECOIL STARTER INSTALLATION

Install the recoil starter.

Install the neutral indicator by aligning the indicator boss with the recoil starter housing "N" mark.

Install the circlip.

Install the gearshift pedal.

Check that the indicator aligns with the "N" mark when the transmission is in neutral.

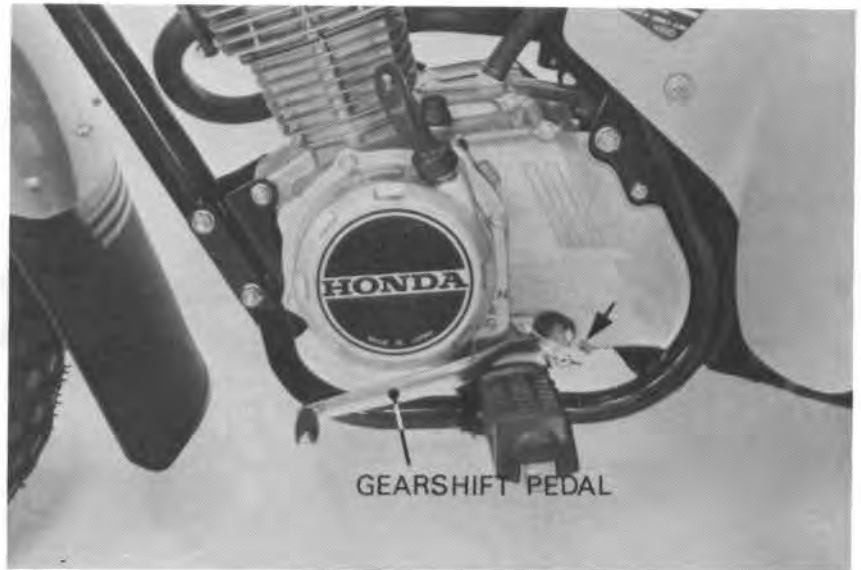

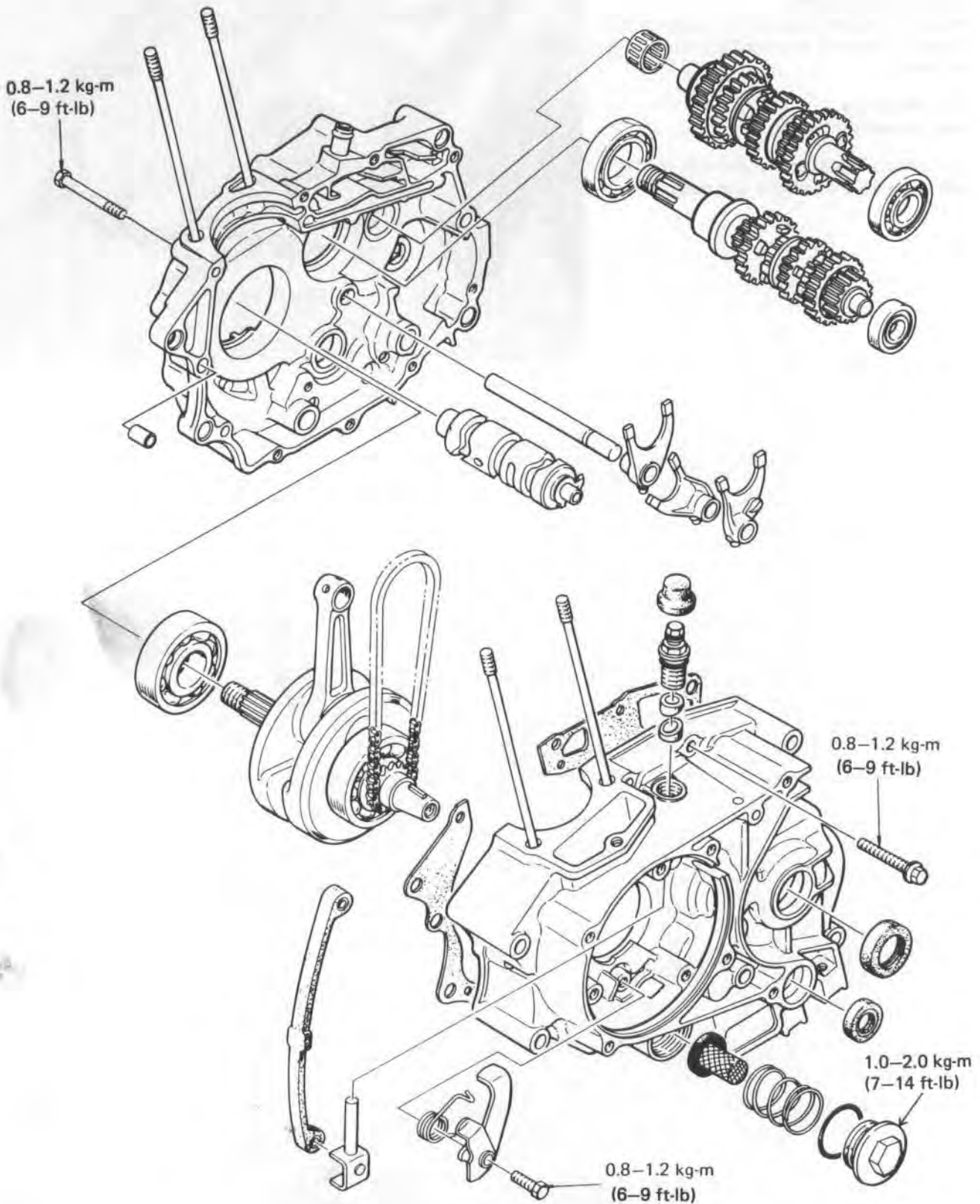





SERVICE INFORMATION	10-1
TROUBLESHOOTING	10-1
CRANKCASE SEPARATION	10-2
CRANKSHAFT REMOVAL	10-3
TRANSMISSION DISASSEMBLY	10-5
TRANSMISSION ASSEMBLY	10-7
CRANKCASE ASSEMBLY	10-8

## SERVICE INFORMATION

### GENERAL INSTRUCTIONS

- Use care not to damage the oil pressure pad on the crankshaft right end.
- The crankcase must be separated to service the crankshaft and transmission.
- Remove the following parts before separating the crankcase.
  - Cylinder head Section 6
  - Cylinder and piston Section 7
  - Clutch and gearshift linkage Section 8
  - A. C. Generator Section 9

### SPECIFICATIONS

ITEM		STANDARD	SERVICE LIMIT	
Shift fork, guide shaft	Fork	I. D.	12.016–12.034 mm (0.473–0.474 in)	
		Claw thickness	4.93 – 5.00 mm (0.194–0.197 in)	
	Shaft	O. D.	11.976–11.994 mm (0.4715–0.4722 in)	11.96 mm (0.471 in)
Crankshaft	Connecting rod small end I. D.		15.010–15.028 mm (0.5909–0.5917 in)	15.06 mm (0.593 in)
	Connecting rod big end axial clearance		0.05 – 0.30 mm (0.002 –0.012 in)	0.80 mm (0.032 in)
	Connecting rod big end radial clearance		0–0.008 mm (0–0.0003 in)	0.05 mm (0.002 in)
	Runout			0.05 mm (0.002 in)

## TROUBLESHOOTING

### Hard to shift

1. Shift fork bent
2. Shift fork shaft bent

### Transmission jumps out of gear

1. Gear dogs worn
2. Shift fork bent or damaged
3. Shift fork shaft bent

### Crankshaft noisy

1. Worn connecting rod big end bearing
2. Bent connecting rod
3. Worn crankshaft main journal bearing

### Gears noisy

1. Worn transmission gear
2. Worn spline shafts



## CRANKCASE SEPARATION

Remove the cam chain tensioner adjusting bolt.

Remove the cam chain tensioner arm.  
Remove the cam chain tensioner and cam chain.

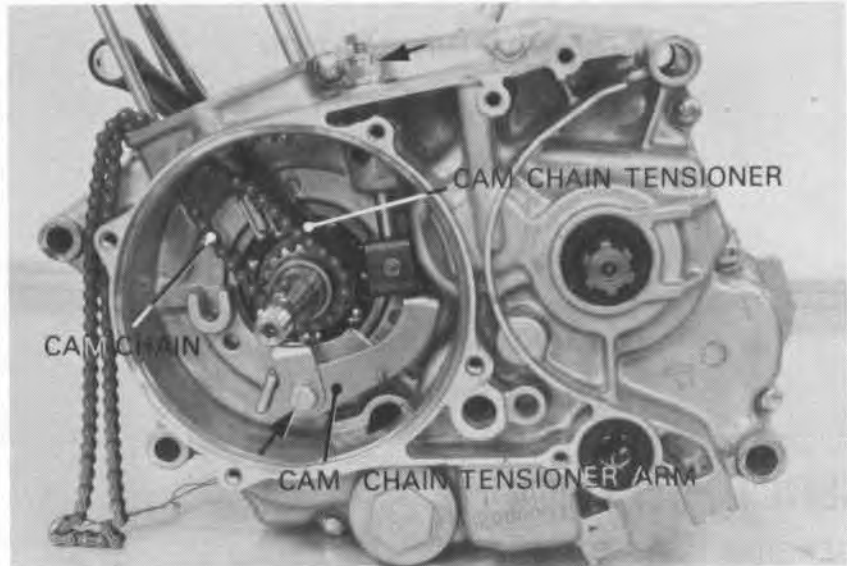

Remove the left crankcase 6 mm bolts.

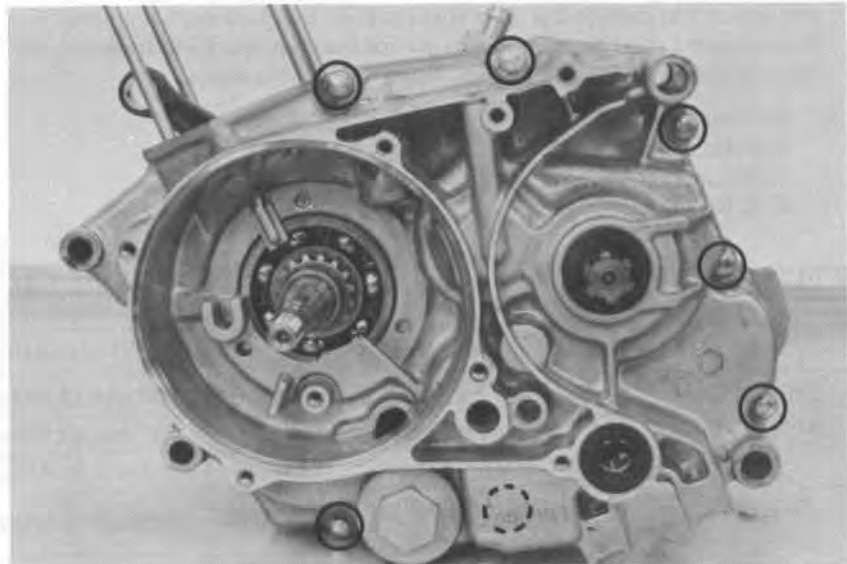

Set the engine on the left crankcase.  
Remove the 6 mm bolt.

Separate the right crankcase from the left crankcase.

Remove the gasket and dowel pins.

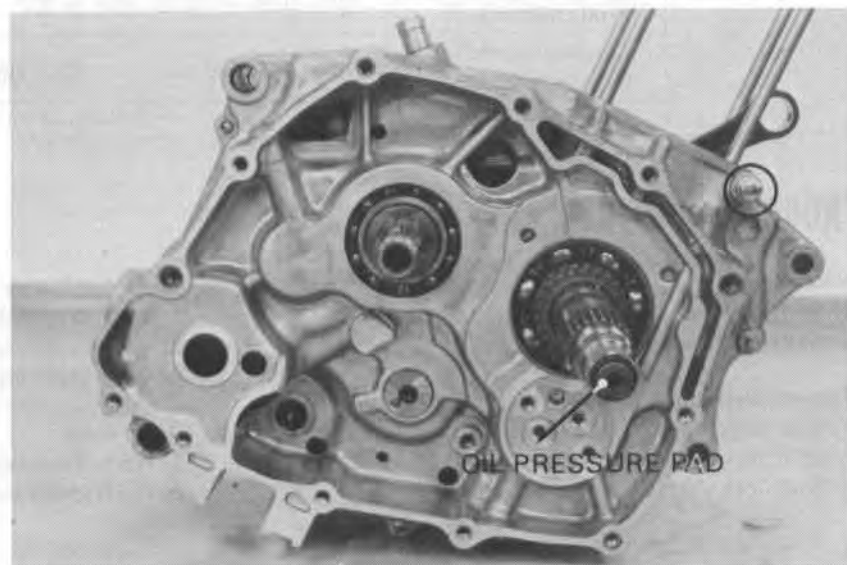



## CRANKSHAFT REMOVAL

Remove the crankshaft.  
Do not damage the oil pressure pad.

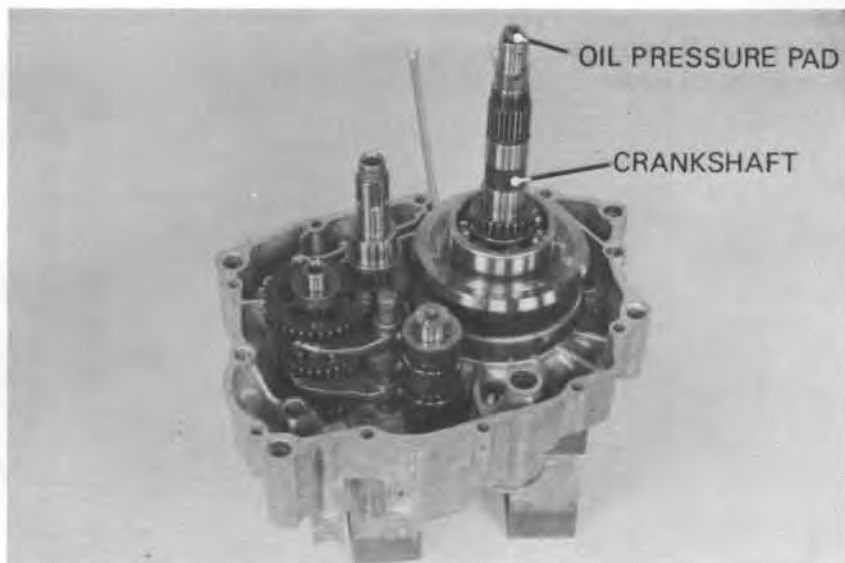

## CRANKSHAFT INSPECTION

Set the crankshaft on a stand or V-blocks and read the runout using a dial indicator.

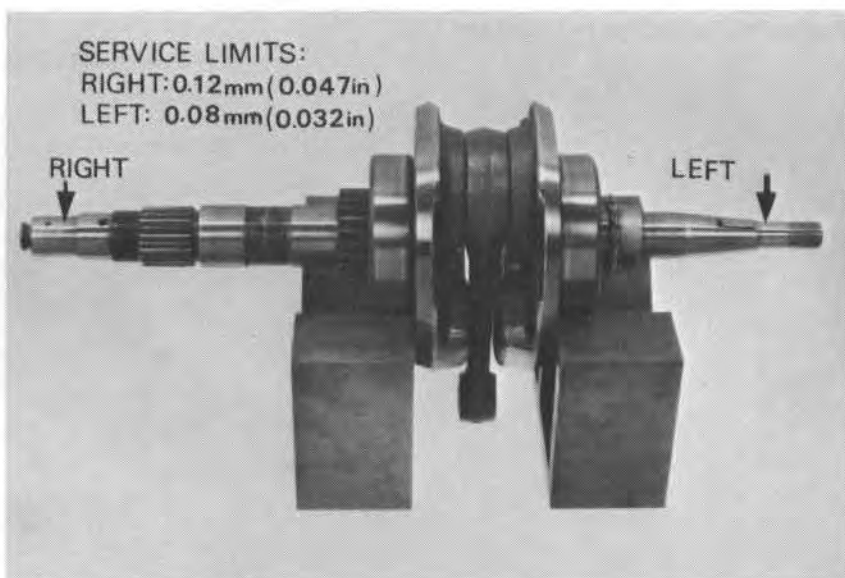

Measure the side clearance at the connecting rod big end with a feeler gauge.





**TRANSMISSION/CRANKSHAFT**

Measure the radial clearance at the connecting rod big end, at two points in the direction indicated by the arrows.

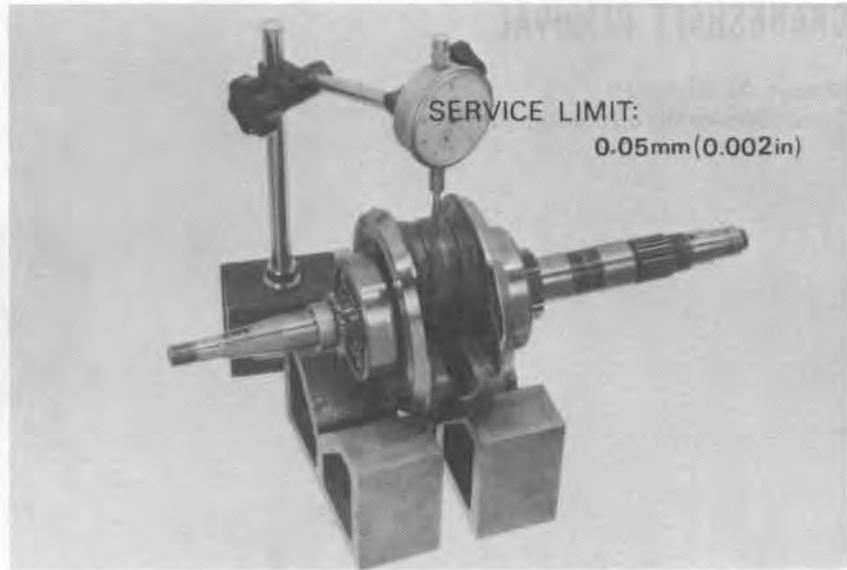

Measure the connecting rod small end I. D.



**CRANKSHAFT BEARING INSPECTION**

Spin the crankshaft bearing by hand and check for play.

The bearing must be replaced if it is noisy or has excessive play.

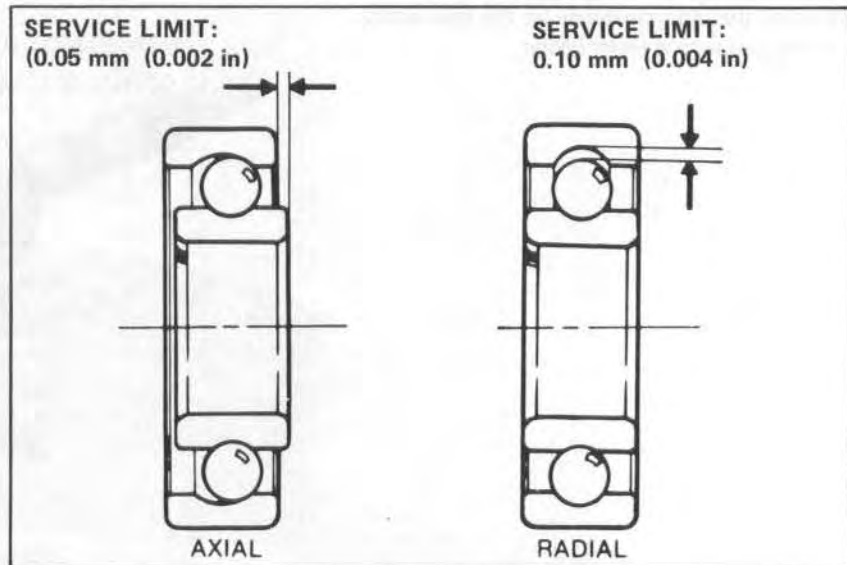



**TIMING SPROCKET  
INSTALLATION**

Install the sprocket, aligning any tooth center with the keyway center in the crankshaft.

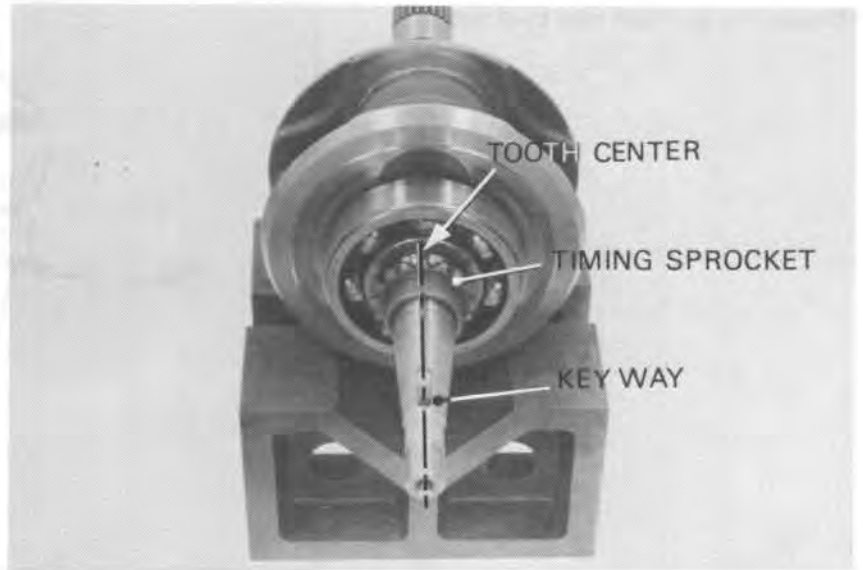

**TRANSMISSION DISASSEMBLY**

Remove the shift fork shaft and remove the shift forks.

Remove the shift drum.

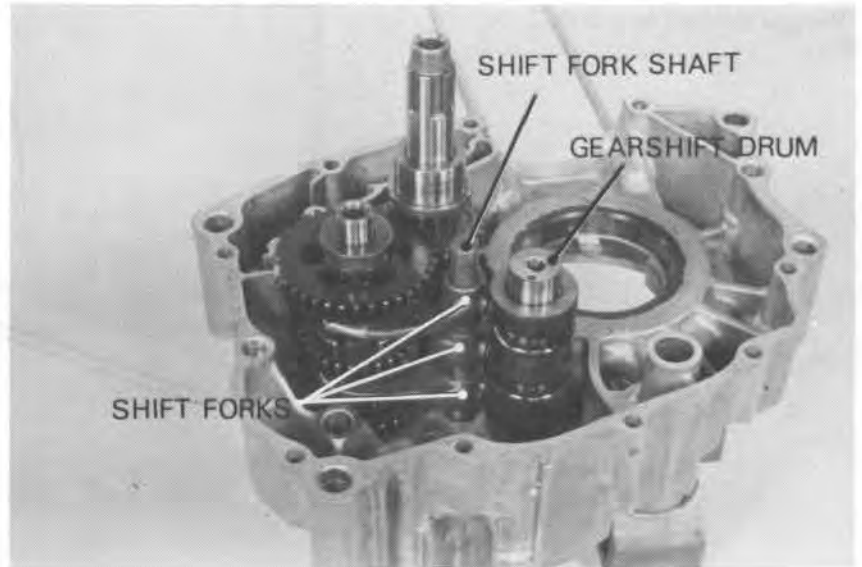

**SHIFT FORK/SHIFT SHAFT  
INSPECTION**

Check the shift fork for wear, bending or any damage.

Measure the I. D.

**STANDARD:**  
12.016–12.034 mm (0.473–0.474 in)  
**SERVICE LIMIT:**  
12.05 mm (0.474 in)

WEAR OR DAMAGE



**TRANSMISSION/CRANKSHAFT**

Measure the shift fork claw thickness.

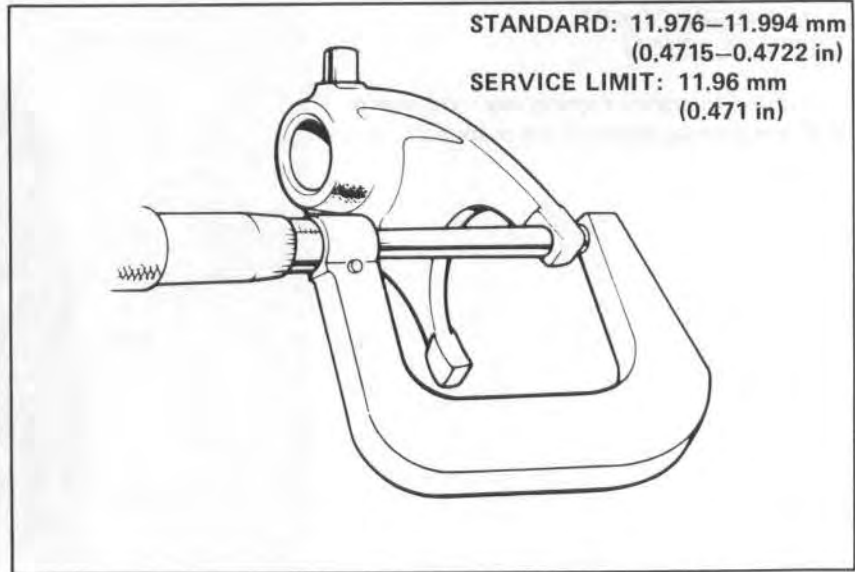

Measure the shift fork shaft O. D.

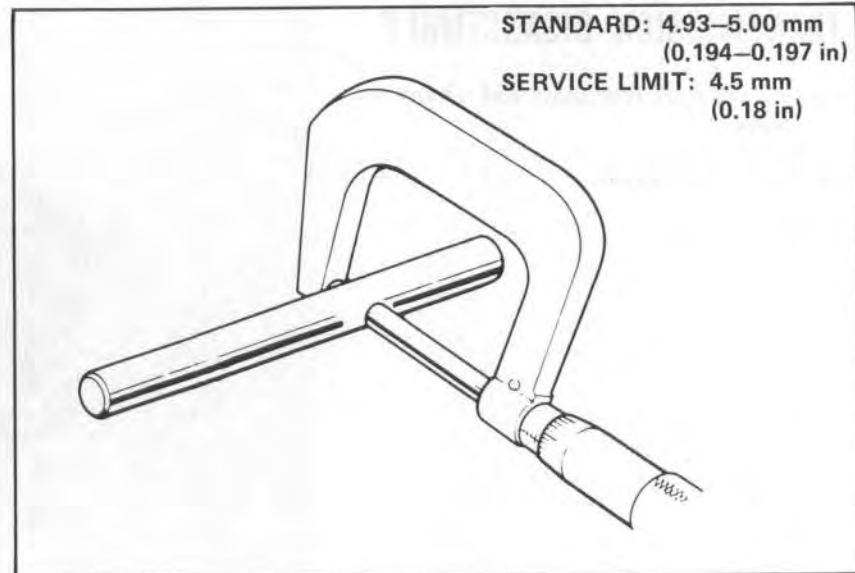

Remove the transmission gears.

Inspect each gear for wear or damage and replace if necessary.

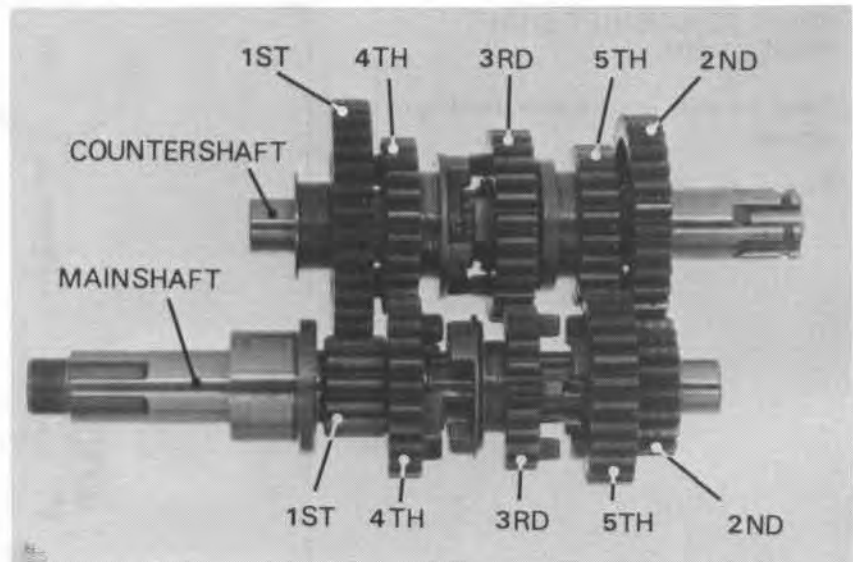



## TRANSMISSION ASSEMBLY

Coat all parts with oil.

Assemble the transmission shafts and gears noting the locations of the thrust washers and snap rings.

**NOTE**

Make sure the snap rings are seated properly.

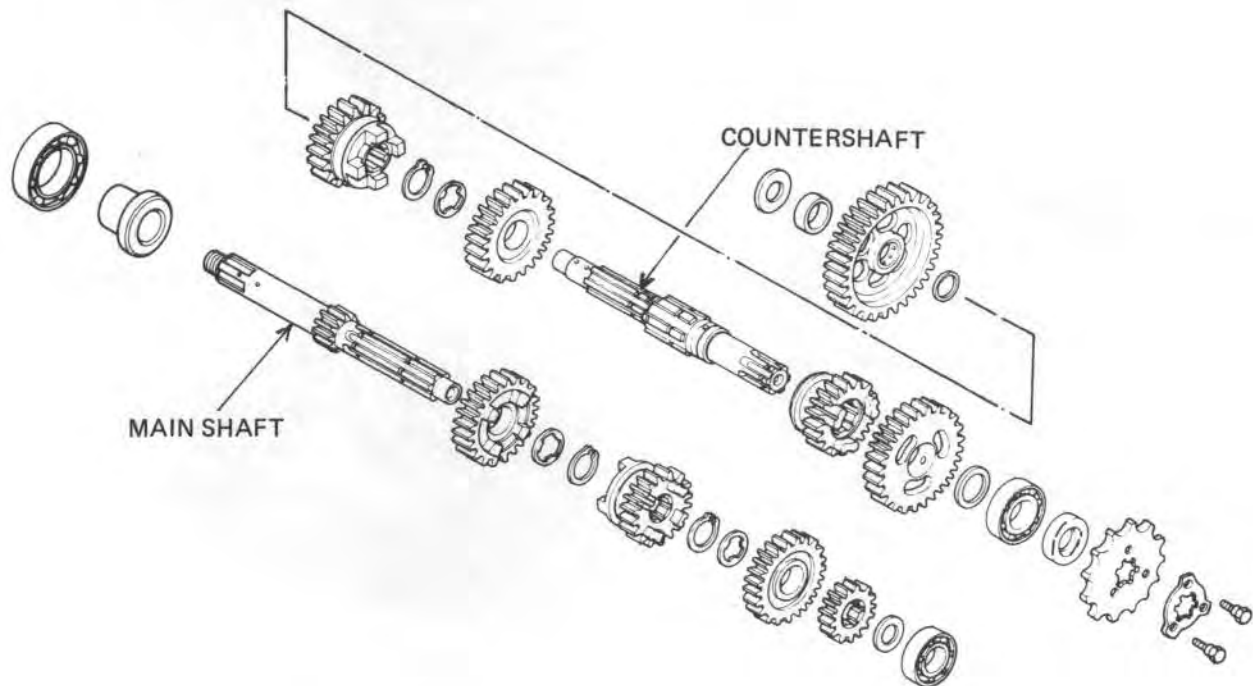

Install the mainshaft and countershaft assemblies in the left crankcase.

**NOTE**

Make sure the thrust washer stays in place during this operation.

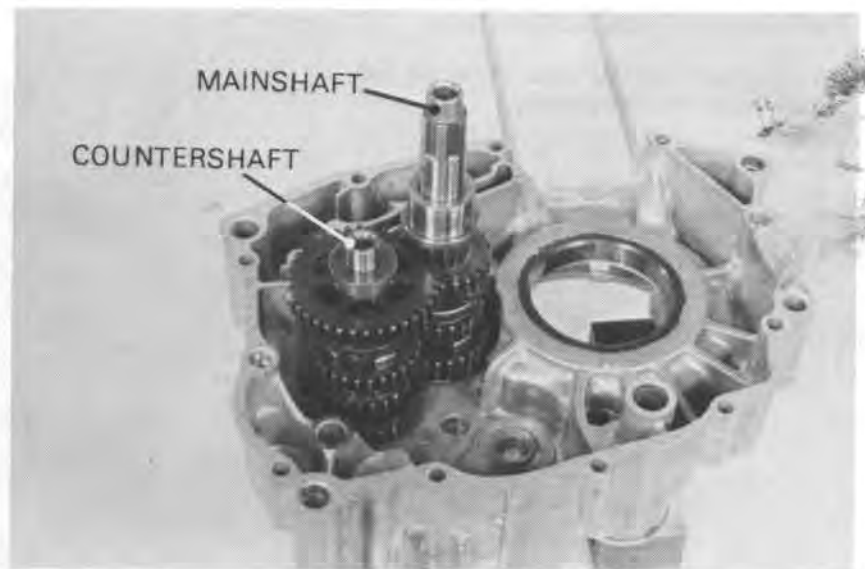



## TRANSMISSION/CRANKSHAFT

Install the shift drum.  
Install the shift forks.

Install the fork guide shaft.  
Rotate the manishaft by hand to see if the gears rotate freely.

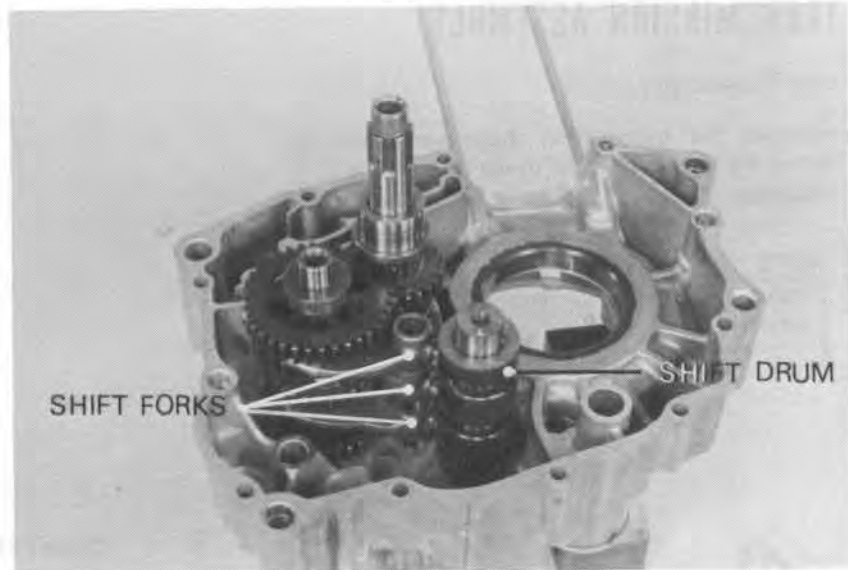

## CRANKCASE ASSEMBLY

Install the crankshaft.  
Install the gasket and dowel pins.

Install the right crankcase on the left crankcase.

### NOTE

Make sure that the gasket stays in place during this operation.

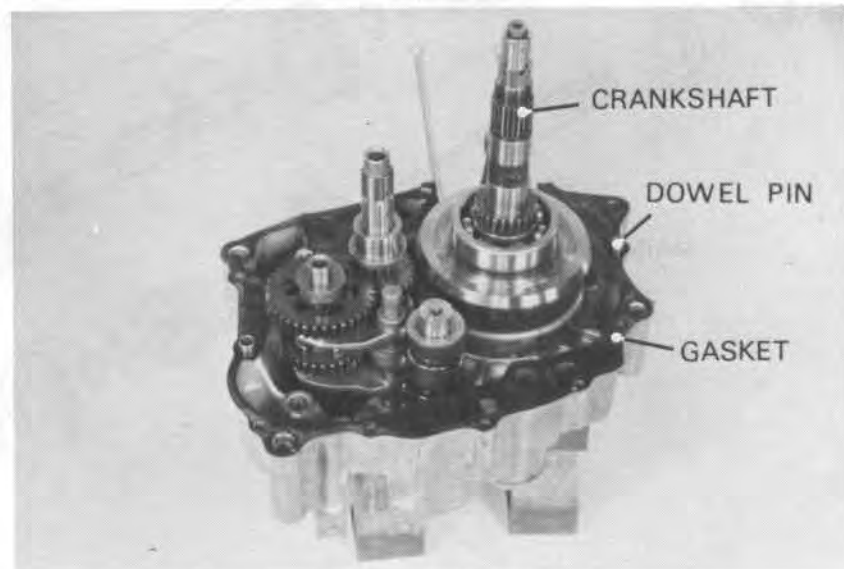

Tighten the right crankcase 6 mm bolts.

Lay the engine on its right crankcase and tighten the 6 mm bolts securely.

### NOTE

Tighten the bolts in a crisscross pattern in 2-3 steps.

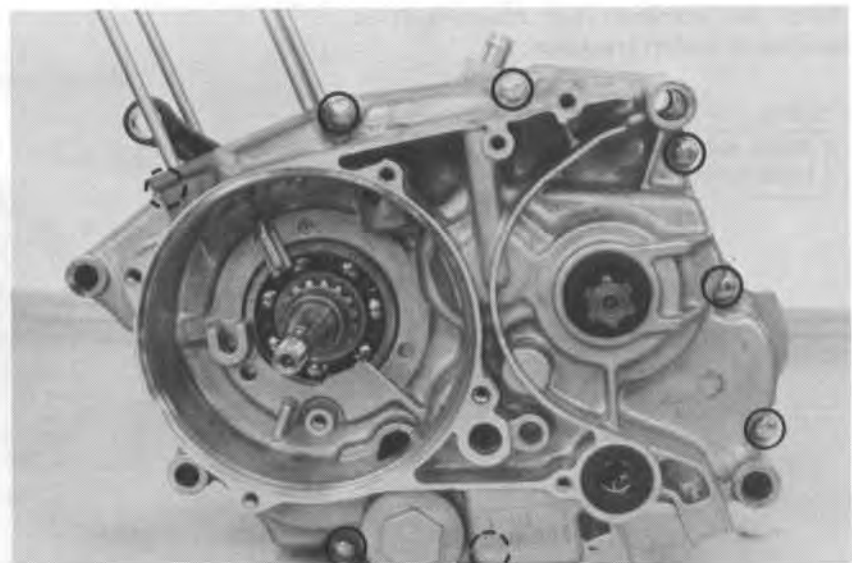





Install the cam chain tensioner and tensioner rod.

Install the cam chain and tensioner arm.  
Install the tensioner lock collar.

With the tensioner arm held down all the way,  
tighten the adjusting bolt.

**NOTE**

Note the tensioner lock collar direction.

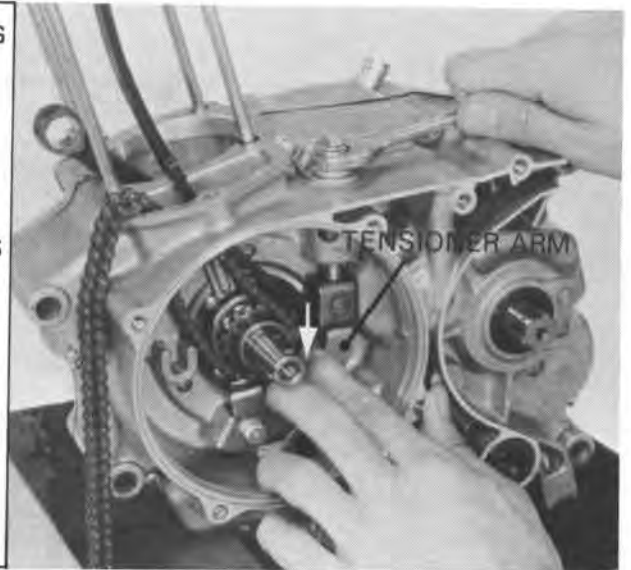
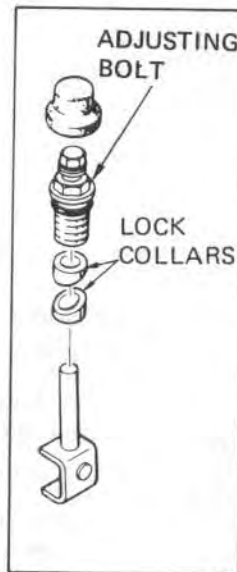



**FRONT WHEEL/BRAKE/STEERING**

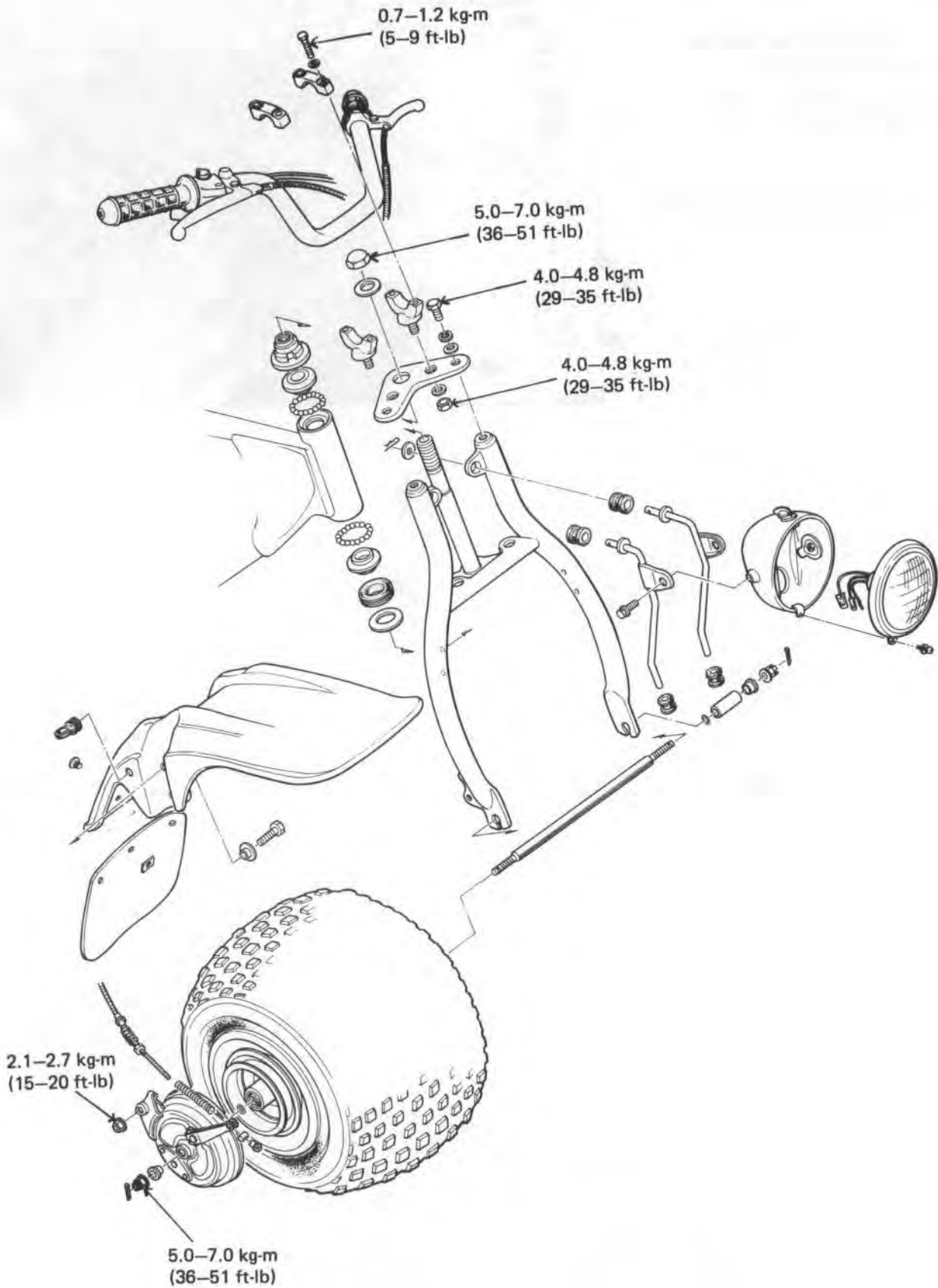



SERVICE INFORMATION	11-1
TROUBLESHOOTING	11-2
HEADLIGHT	11-3
HANDLEBAR	11-4
FRONT WHEEL	11-8
FRONT BRAKE	11-16
STEERING STEM/FRONT FORK	11-18

## SERVICE INFORMATION

### GENERAL INSTRUCTIONS

- \* This section covers maintenance of the front wheel, front brake and steering system.
- \* A jack or other support is required to support the ATC.

### TOOLS

#### Special

Ball Race Remover 07944-1150001 or 07944-1150000  
Tire Disassembling Tool 07722-0010000 or M987X-350-XXXX

#### Common

Pin Spanner 07702-0010000 or 07902-0010000  
Socket Wrench 30 x 32 mm 07716-0020400 or 07907-6890100  
Extension Bar 07716-0020500 Commercially available in USA  
Bearing Driver Handle Outer A 07749-0010000 or 07949-6110000  
Bearing Driver Outer 37 x 40 mm 07746-0010200  
Driver Pilot 15 mm 07746-0040300  
Bearing Driver Outer 42 x 47 mm 07746-0030300 or 7946-9350200

### SPECIFICATIONS

ITEM		STANDARD	SERVICE LIMIT
Front axle runout		(22.23 in)	0.5 mm (0.02 in)
Front brake drum I. D.		110 mm (4.3 in)	111 mm (4.4 in)
Front brake lining thickness		4 mm (0.2 in)	2 mm (0.1 in)
Front wheel bearing play	Radial	_____	0.05 mm (0.002 in)
	Axial	_____	0.1 mm (0.004 in)



**FRONT WHEEL/BRAKE/STEERING**

**TORQUE VALUES**

Handlebar upper holder bolt	0.7–1.2 kg-m (5–9 ft-lb)
Handlebar lower holder nut	4.0–4.8 kg-m (29–35 ft-lb)
Fork top bridge bolt	4.0–4.8 kg-m (29–35 ft-lb)
Steering stem nut	5.0–7.0 kg-m (36–51 ft-lb)
Front axle nut	5.0–7.0 kg-m (36–51 ft-lb)
Front wheel hub nut	1.9–2.5 kg-m (14–18 ft-lb)
Front brake drum bolt	1.9–2.5 kg-m (14–18 ft-lb)
Front brake panel bolt	2.1–2.7 kg-m (15–20 ft-lb)
Front rim nut	1.9–2.5 kg-m (14–18 ft-lb)

**TROUBLESHOOTING**

**Hard steering**

1. Steering stem nut too tight
2. Faulty steering stem bearings
3. Damaged steering stem ball race and/or cone race
4. Insufficient tire pressure

**Steers to one side or does not track straight**

1. Bent front forks
2. Bent front axle, wheel installed incorrectly

**Front wheel wobbling**

1. Distorted rim
2. Worn front wheel bearing
3. Faulty tire
4. Axle not tightened properly

**Improper brake performance**

1. Incorrect adjustment of lever
2. Brake shoes worn
3. Brake shoes contaminated
4. Brake cam worn
5. Brake drum worn
6. Brake arm serrations improperly engaged
7. Cam contacting area of shoes worn



## HEADLIGHT

### HEADLIGHT CASE REMOVAL

Remove the headlight.  
Disconnect the wire connectors.

**NOTE**

Do not cut the wires.

Remove the headlight case.

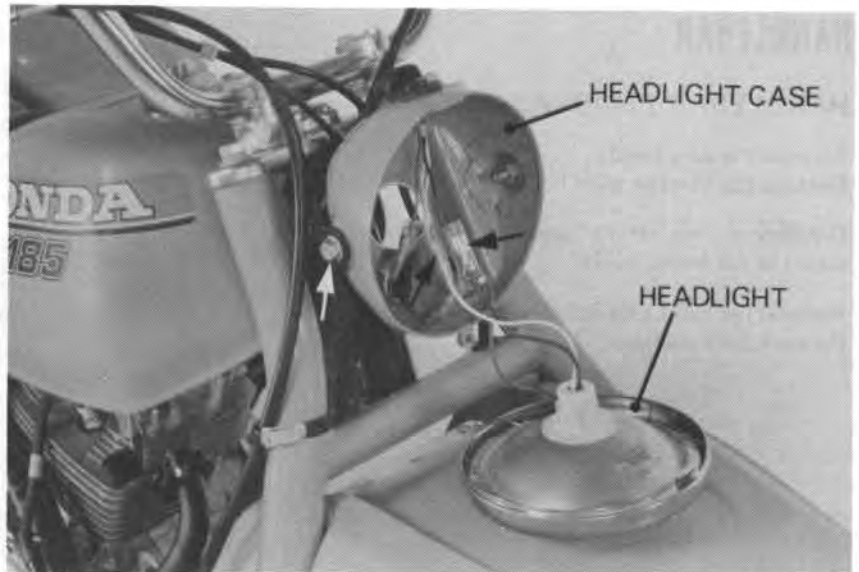

Remove the light switch.

**NOTE**

Install the lighting switch by aligning the groove with the tab of the seat rubber.

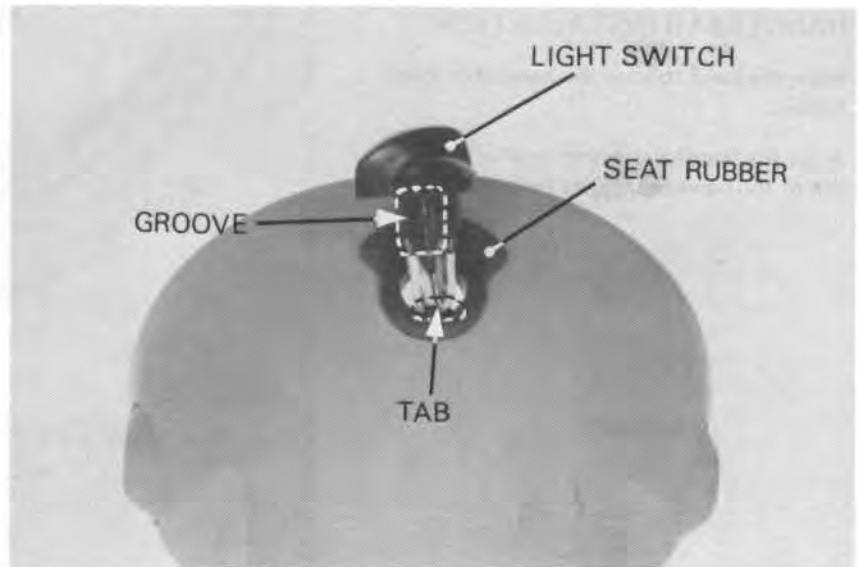

Remove the clip and washer.  
Remove the headlight case bracket.

### HEADLIGHT CASE INSTALLATION

The installation sequence is essentially the reverse order of removal.

**NOTE**

Connect the wires color-to-color.

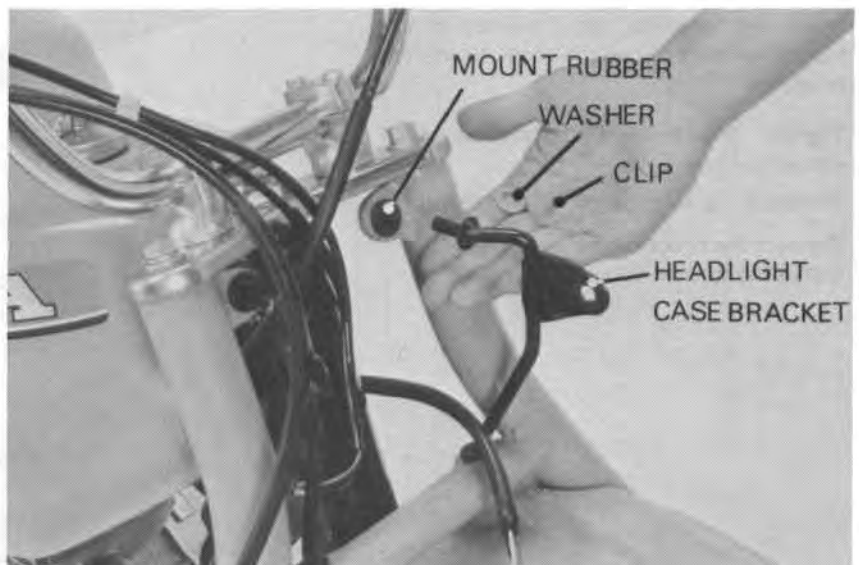



**FRONT WHEEL/BRAKE/STEERING**

**HANDLEBAR**

**HANDLEBAR REMOVAL**

Remove the wire band.  
Remove the throttle lever housing.

Disconnect the front and rear brake cables at the brake levers.

Remove the handlebar holders.  
Remove the handlebar.



**HANDLEBAR INSTALLATION**

Place the handlebar on the handlebar lower holders.

Align the handlebar punch marks with the top of the handlebar lower holders.

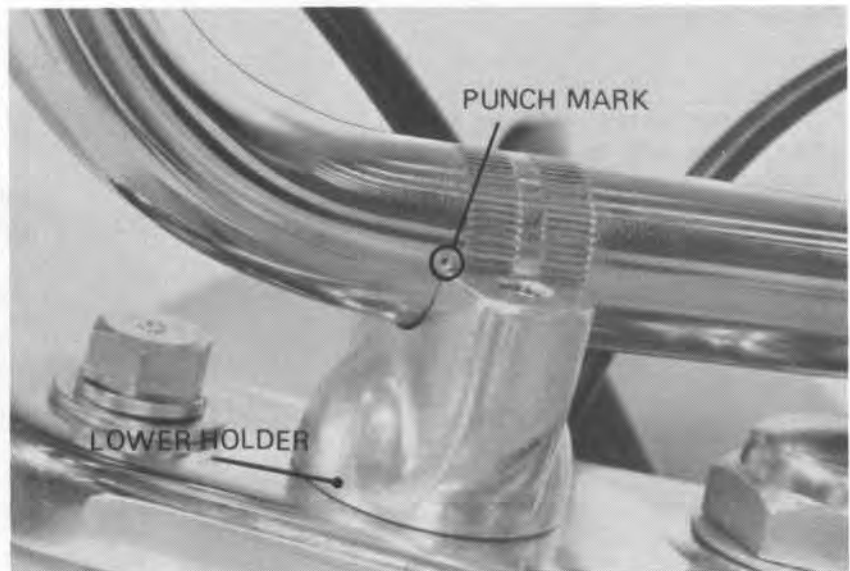

Install the handlebar upper holders on the handlebar with the punch mark facing the front.

Tighten the forward bolts first, then tighten the rear bolts.

**TORQUE: 0.7–1.2 kg-m (5–10 ft-lb)**

Connect the brake cables.  
Install the throttle lever.

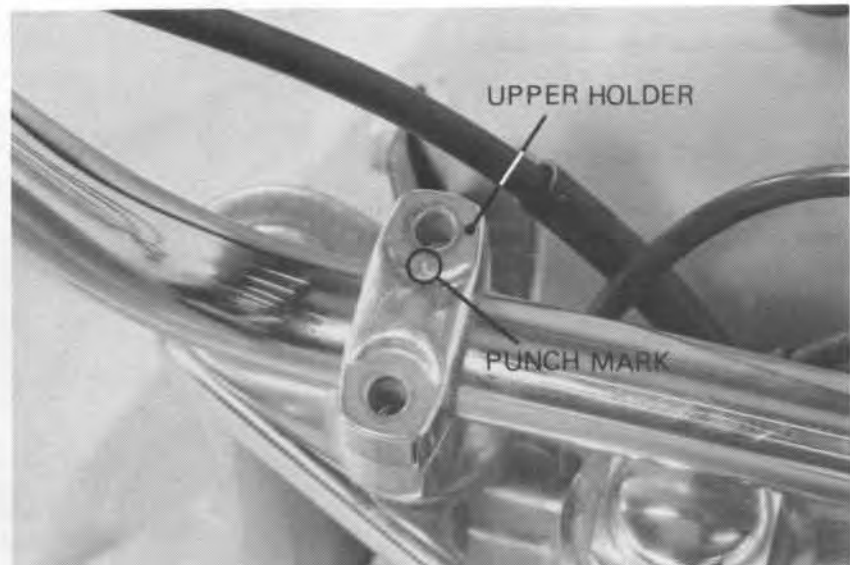



**BRAKE LEVER BRACKET/  
THROTTLE LEVER INSTALLATION**

Install the throttle lever case as shown.  
Tighten the front screw first.

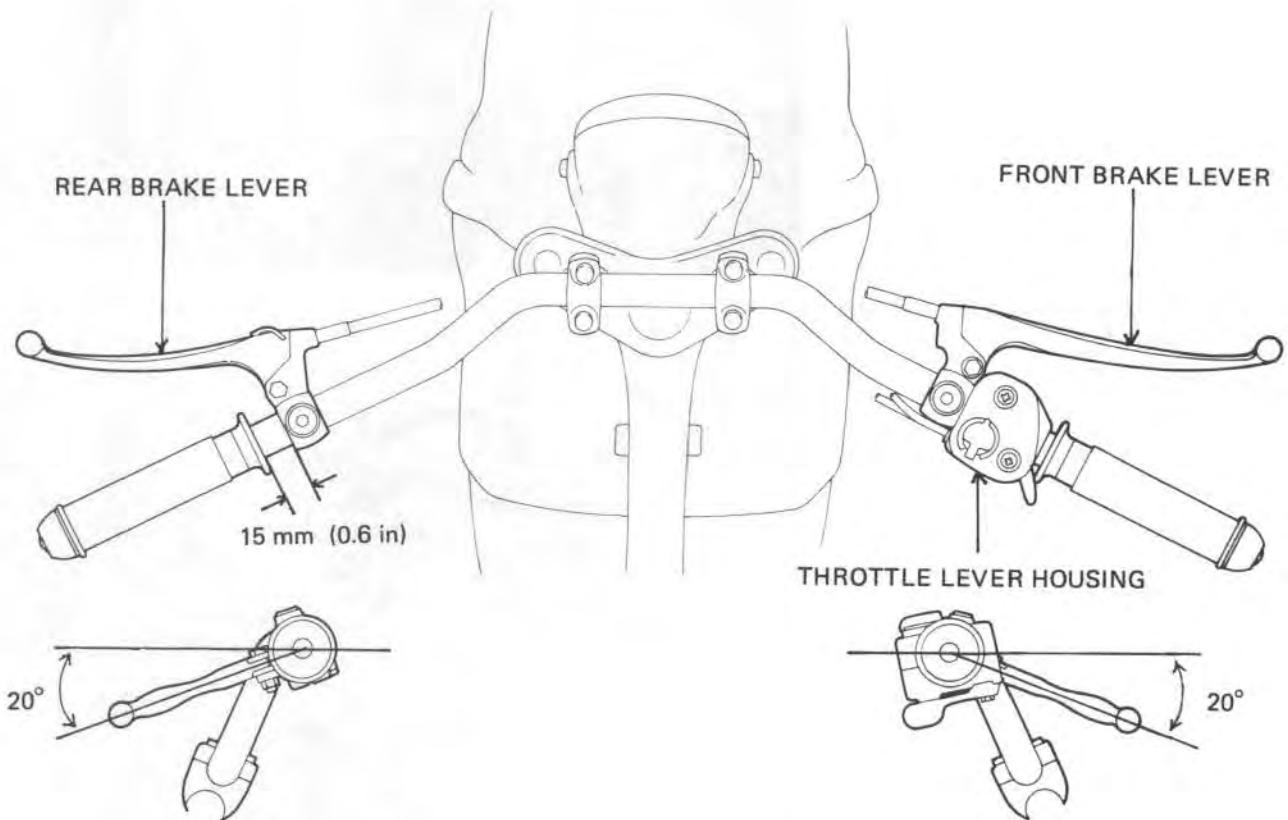

Install the front brake lever bracket as shown.

Install the rear brake (parking brake) lever bracket as shown.





**FRONT WHEEL/BRAKE/STEERING**

**THROTTLE LEVER DISASSEMBLY**

Remove the headlight and disconnect the engine stop switch wire connector.

Remove the screws and throttle lever cover.



Pull the engine stop switch out from the throttle lever cover.

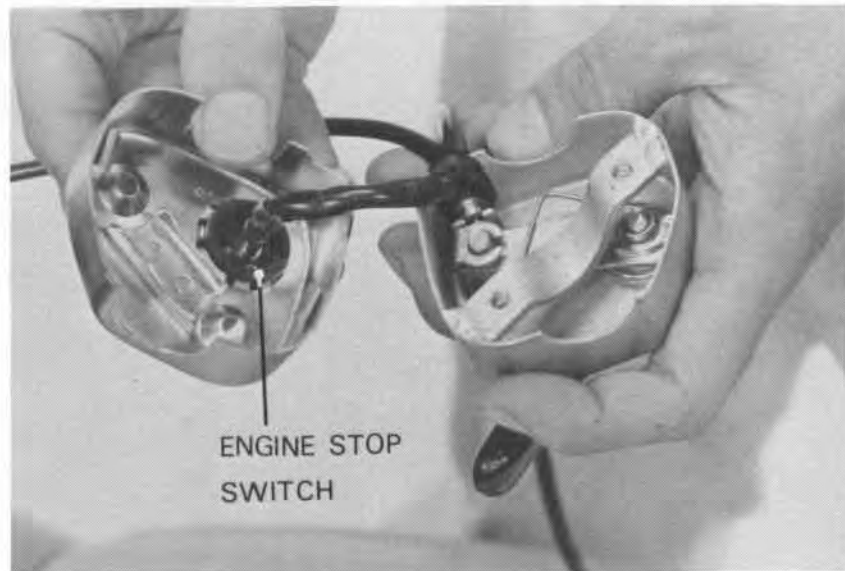

Raise the tab of the lock plate and remove the bolt.

Remove the throttle lever and spring. Disconnect the throttle cable.







**THROTTLE LEVER ASSEMBLY**

Coat the throttle lever and seal with grease and connect the throttle cable.

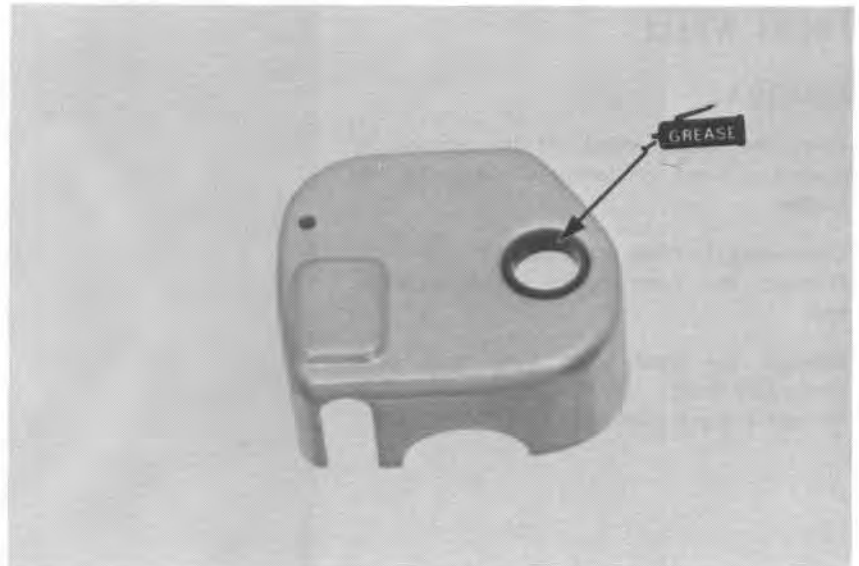

Install the throttle lever and spring.  
Install the rubber seal.

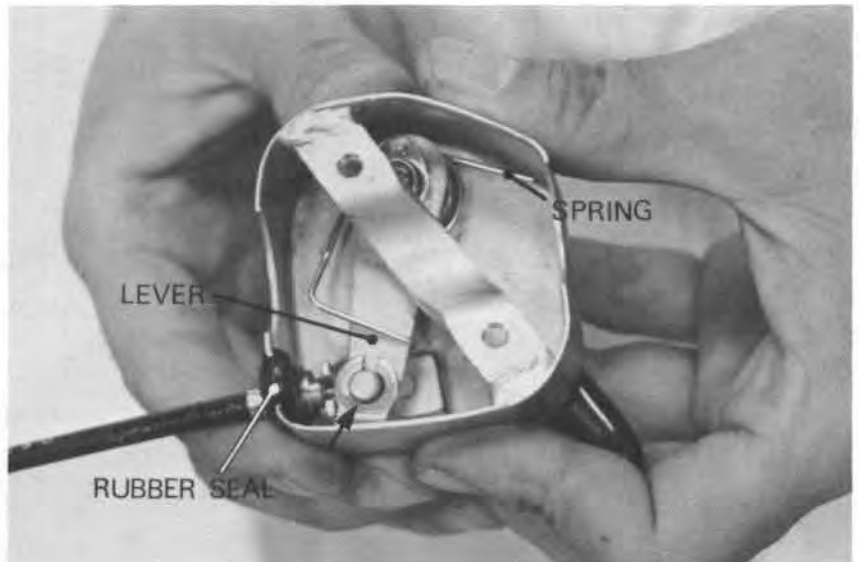

Install the lock plate.  
Screw in the pivot bolt and check the lever for smooth operation.

Bend the tabs of the lock plate.  
Install the engine stop switch on the throttle lever cover.

Install the throttle lever case onto the handlebar (Page 11-6).

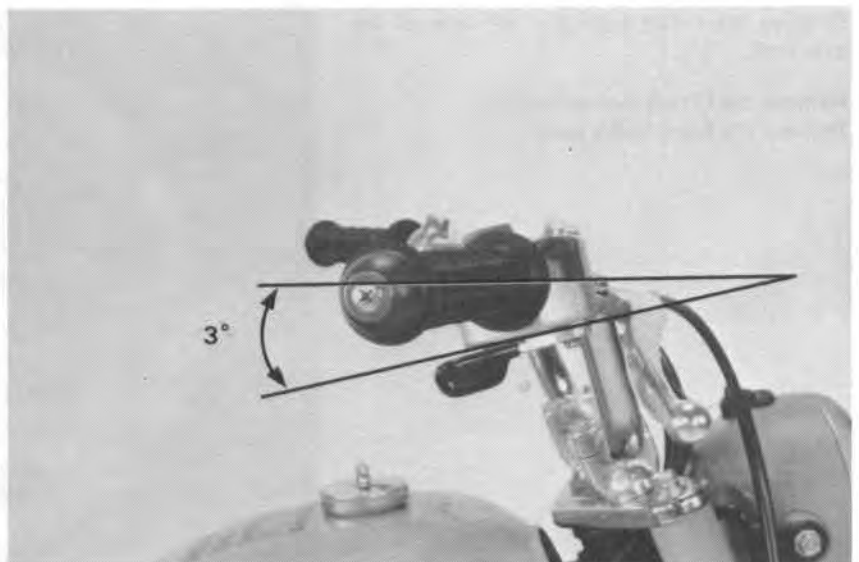



**FRONT WHEEL/BRAKE/STEERING**

**FRONT WHEEL**

**REMOVAL**

Raise the front wheel off the ground by placing a block or safety stand under the engine.

Disconnect the front brake cable.  
Remove the front brake panel attaching bolt.

Remove the cotter pins from both sides of the axle shaft.  
Remove the axle nuts from both sides.



Remove the front axle collars and remove the front wheel.



Remove the collar from the left side of the axle shaft.

Remove the O-ring and axle shaft.  
Remove the front brake panel.

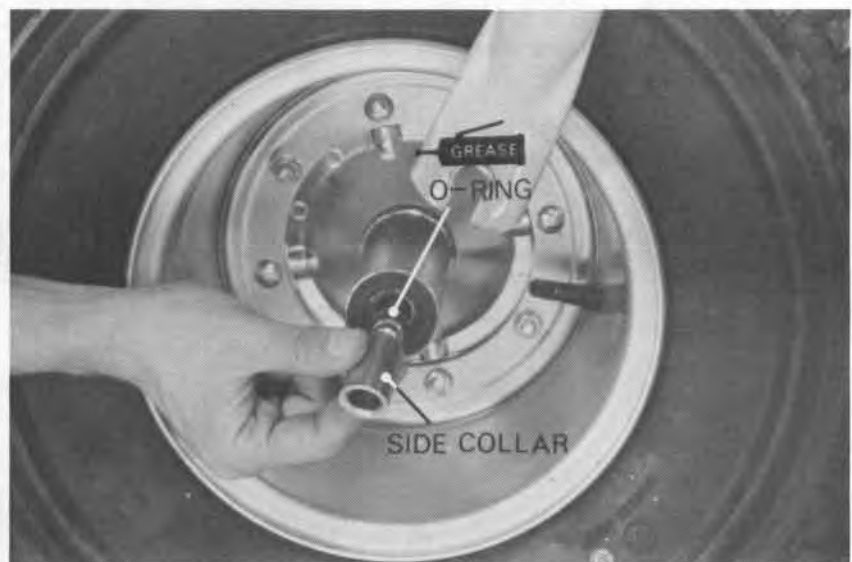



**FRONT AXLE INSPECTION**

Set the axle in V-blocks, rotate and measure the runout.

Actual runout is 1/2 of TIR (Total Indicator Reading).

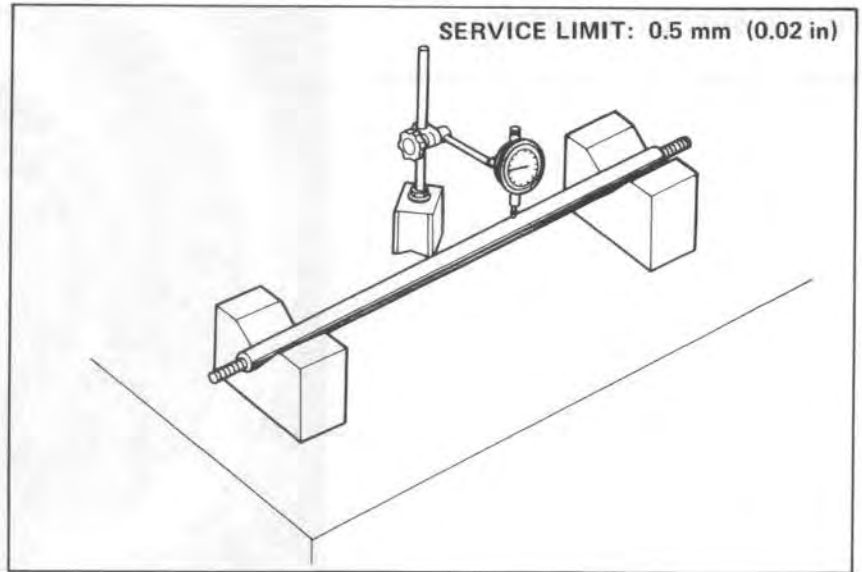

**WHEEL BEARING INSPECTION**

Check the wheel bearings by placing the wheel between V-blocks and spinning the wheel by hand.

Replace the bearings with new ones if they are noisy or have excessive play.

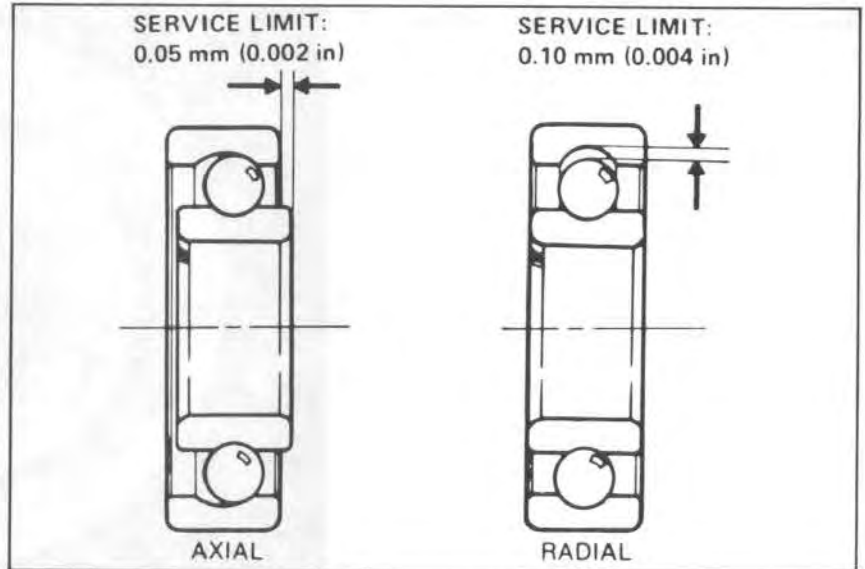

**BRAKE DRUM INSPECTION**

Remove the brake panel assembly. Measure the brake drum I. D.





**FRONT WHEEL/BRAKE/STEERING**

**FRONT WHEEL DISASSEMBLY**

Remove the brake drum bolts and brake drum.

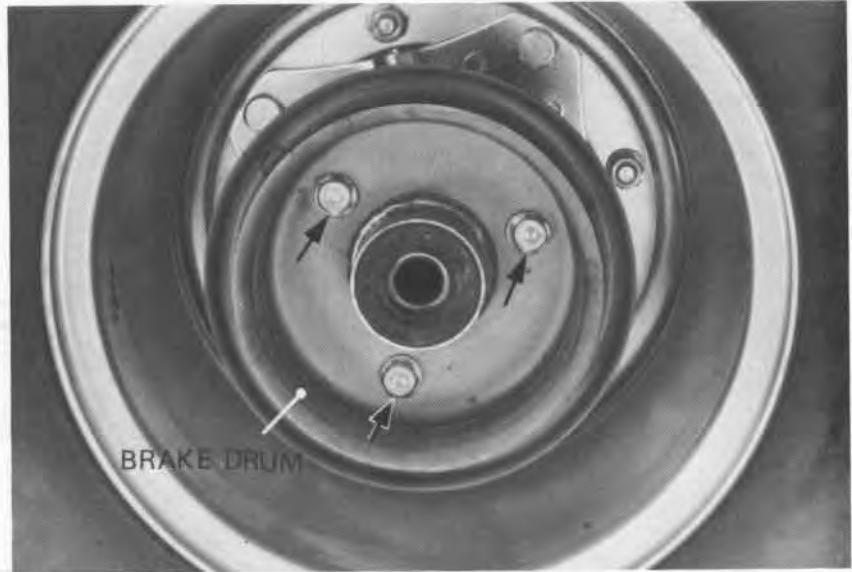

Remove the front wheel hub nuts and hub.

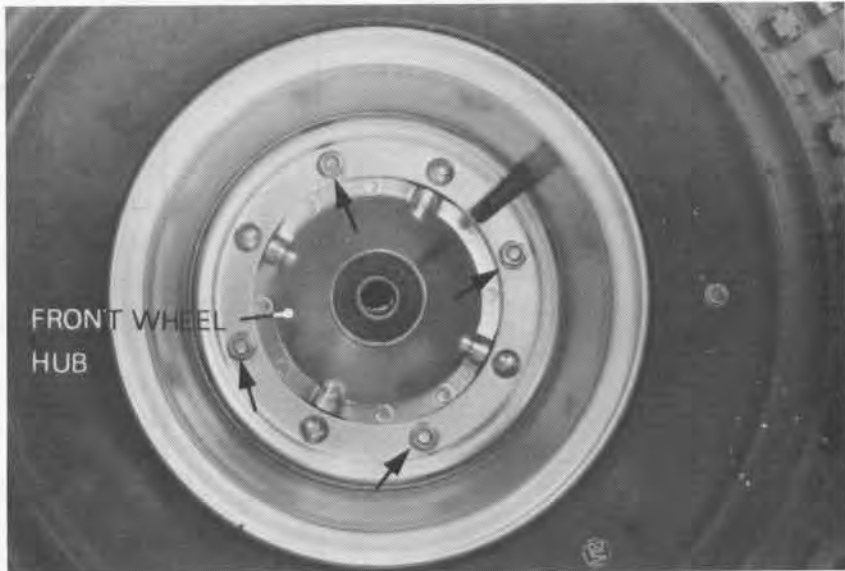

Remove the dust seals.  
Drive the bearings and center collar out.

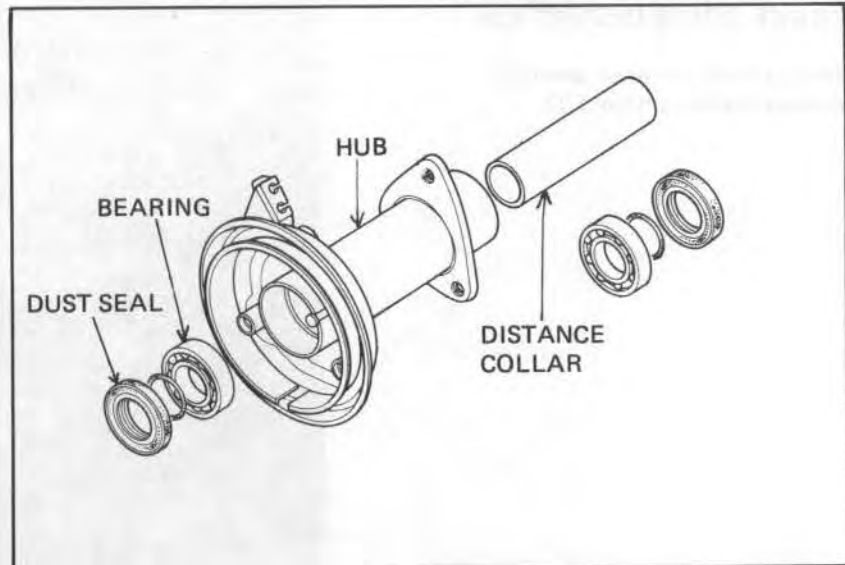



**TIRE REMOVAL**

Deflate the tire.  
Break both tire beads loose.

**NOTE**

- Do not use tire irons to break the bead away from the rim flange; this could damage the rim seal and cause an air leak.
- If it is difficult to break the beads or if rust has formed on the rim, apply a soap and water solution or tire mounting lubricant to the rim periphery.

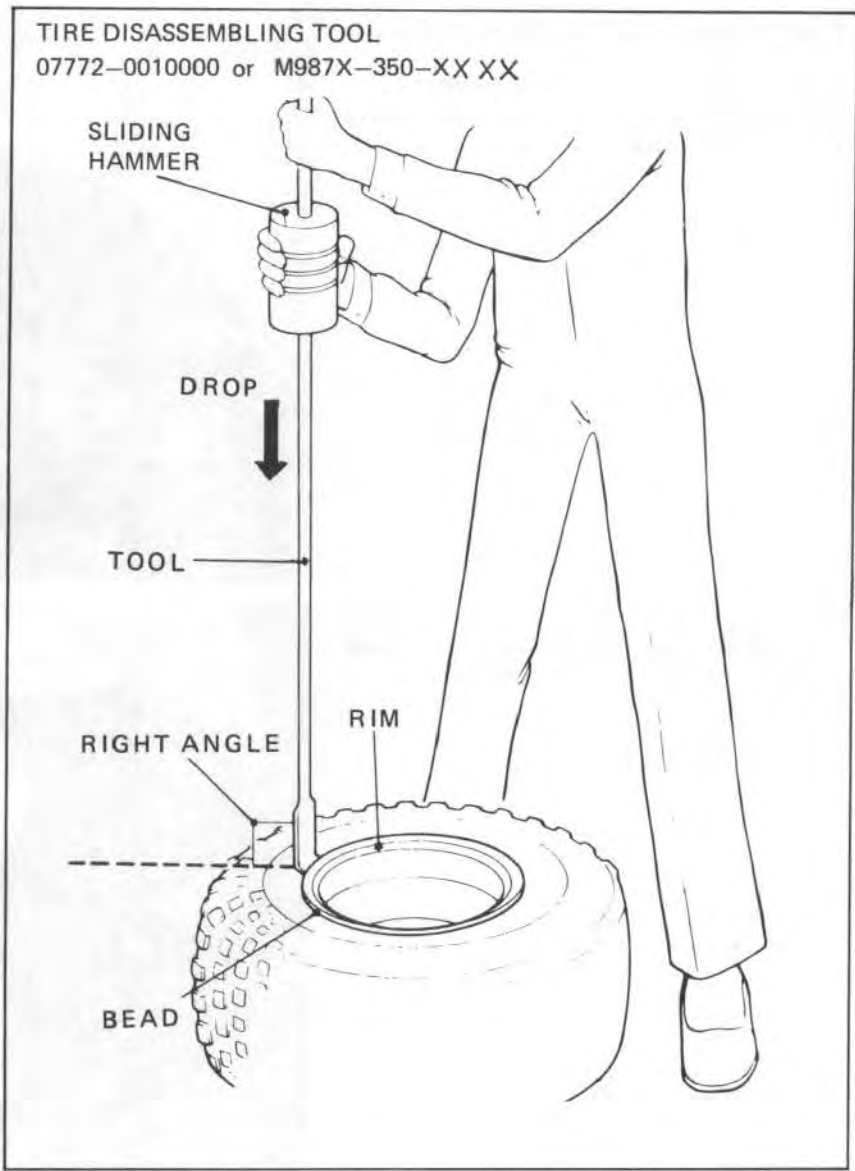

Remove the rim bolts.  
Remove the rim, O-ring and rim plate.

Check the rim for damage.  
Check the tire for cuts, tears, wear or other damage. Replace if necessary.





**FRONT WHEEL/BRAKE/STEERING**

**TIRE REPAIR (WITH COLD PATCH)**

Check the tire tread for puncturing objects. Chalk mark the punctured area and remove the puncturing object.



Clean and roughen the punctured area with a tire rubber cleaner or a wire brush. Clean the area with non-flammable solvent.



Apply rubber cement around the torn area and allow it to dry. Remove the lining from the patch and center it over the injury. Press the patch against the injury using a special roller.

**NOTE**

- Allow cement to dry until tacky before applying patch.
- Do not touch cement surface with dirty or greasy hands.





### TIRE REPAIR (WITH RUBBER PLUG)

#### NOTE

This method is an emergency repair only. Replace the plug at the first opportunity with a cold patch.

Remove the puncturing object.  
Insert a rubber plug through the eye of an inserting needle.

Apply patching cement to the plug.



Center the needle on the plug and insert until the plug is all the way in the tire.  
Twist the needle several times.

Pull the needle straight out so that the plug is about 10 mm (3/8 in) above the tread surface. Trim the plug 2 mm (1/16 in) above the surface.

Repeat the above procedure if the puncture is large.



### TIRE ASSEMBLY

Clean the rim bead seat and flanges.  
Apply clean water to the rim flanges, bead seat and base.





**FRONT WHEEL/BRAKE/STEERING**

Insert the rim plate into the tire.

Place the rim with the valve on the rim plate and position the tire.

Seat a new O-ring in the groove of the rim.

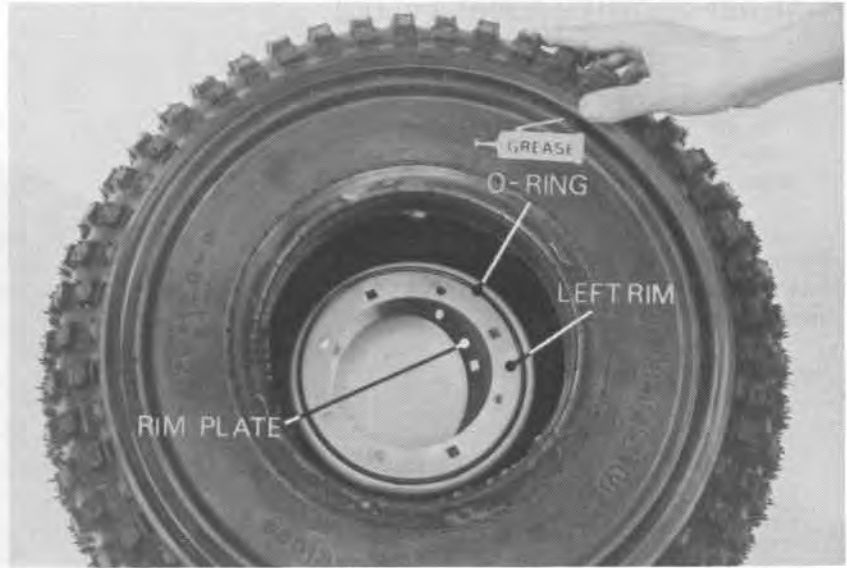

Install the other rim and rim plate.  
Align the rim bolt holes and install the bolts.

Install each washer and tighten the nuts.

**TORQUE: 1.9–2.5 kg-m (14–18 ft-lb)**

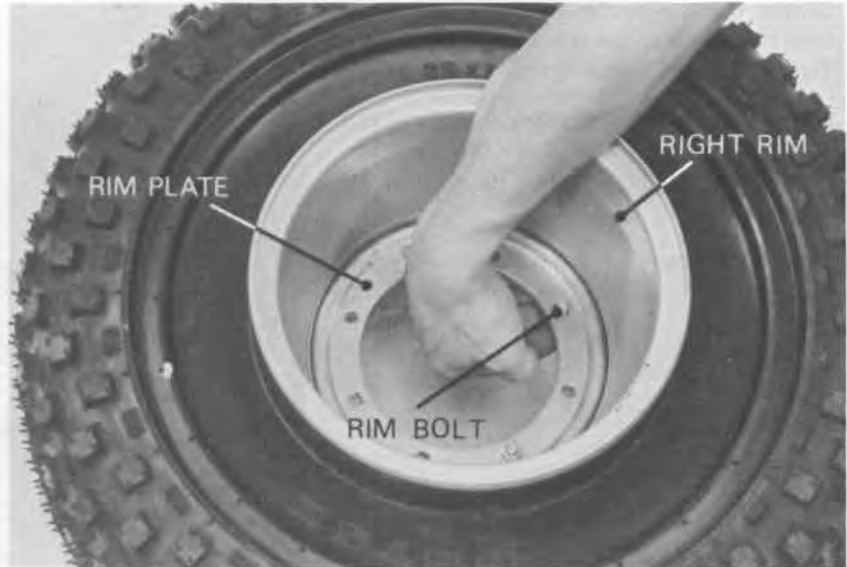

Inflate the tire to seat the tire bead.

**NOTE**

Use tire mounting lubricant or a soap and water solution to help seat the tire bead.

Deflate the tire. Wait 1 hour and inflate the tire to the specified pressure.

**TIRE PRESSURE: 0.15 kg/cm<sup>2</sup> (2.2 psi)**

Measure the tire circumference.

**STANDARD TIRE CIRCUMFERENCE:**  
**1.948 mm (76.7 in)**

Check for air leaks and install the valve cap.







**FRONT WHEEL ASSEMBLY**

Pack all front wheel bearing cavities with grease.

Drive in the left bearing.

Install the collar and drive in the right bearing.

**NOTE**

Do not allow the bearings to tilt while driving them in.



Apply grease to the inside of the dust seal.  
Install the dust seal and distance collar.

Install the front wheel hub.  
Tighten the hub nuts.

**TORQUE: 1.9–2.5 kg-m (14–18 ft-lb)**

Install the brake drum.

**TORQUE: 1.9–2.5 kg-m (14–18 ft-lb)**



Insert the front axle.

Apply grease to the O-rings and install them on both sides of the axle.

Install the front brake panel and side collar.





**FRONT WHEEL/BRAKE/STEERING**

Install the front wheel.  
Install the front axle collars.

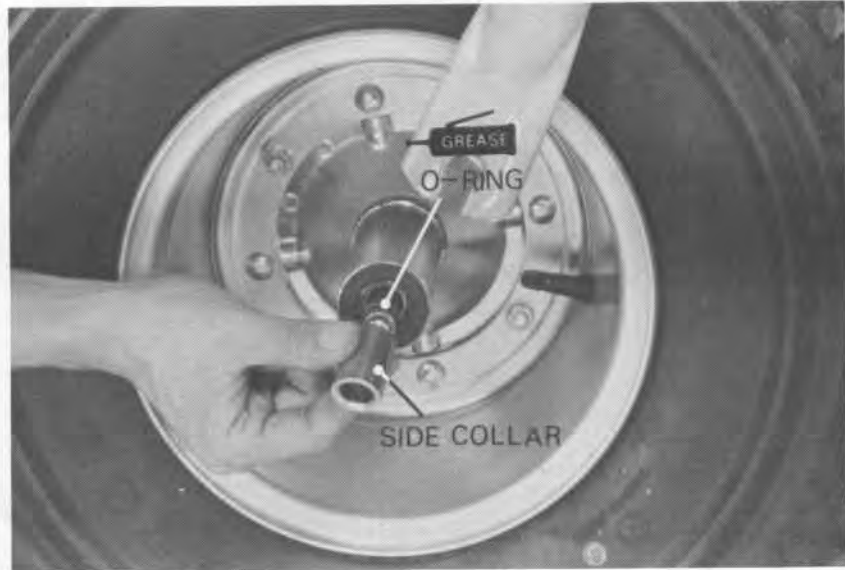

Install the brake panel setting bolt, collar and nut.

**TORQUE: 2.1–2.7 kg-m (15–20 ft-lb)**

Tighten the axle nuts.

**TORQUE: 5.0–7.0 kg-m (36–51 ft-lb)**

Install new cotter pins and bend the ends securely as shown.

Connect the front brake cable and adjust the front brake lever free play (Page 3–11).

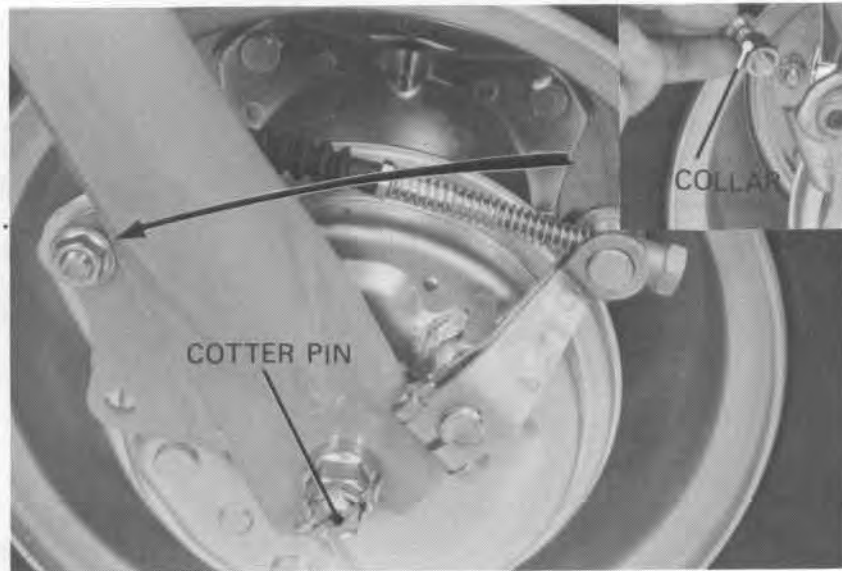

**FRONT BRAKE**

**BRAKE LINING INSPECTION**

Measure the brake lining thickness.

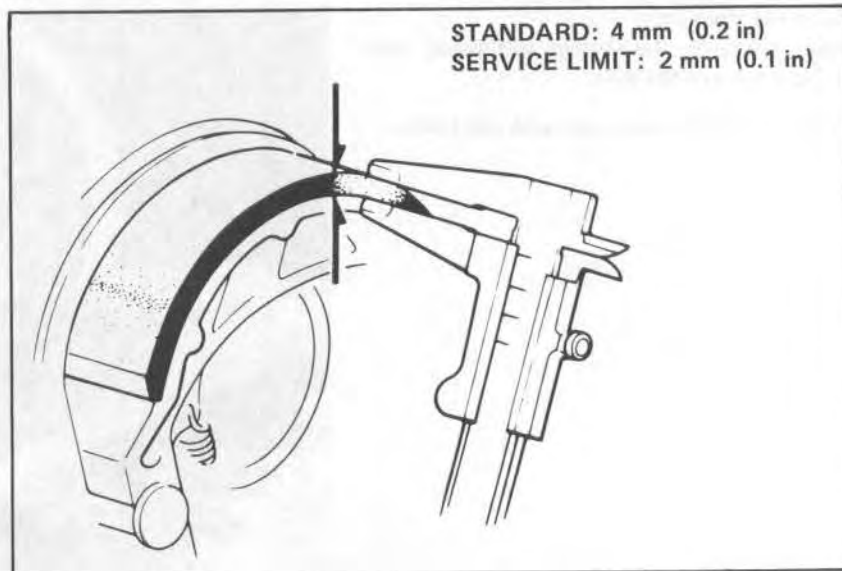



**BRAKE PANEL DISASSEMBLY**

Expand and remove the brake shoes by hand.

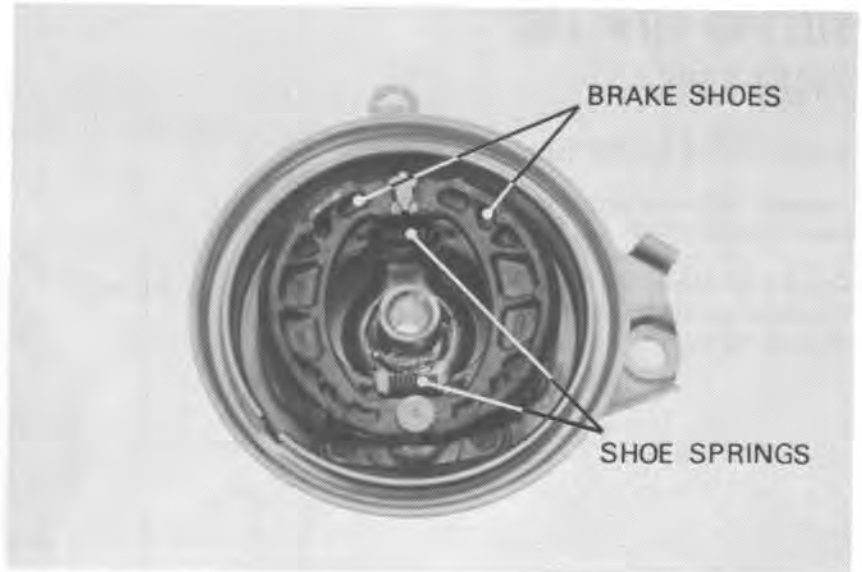

- Remove the brake arm bolt.
- Remove the brake arm and indicator plate.
- Remove the brake cam and thrust washer.
- Remove the rubber seals and dust seal.

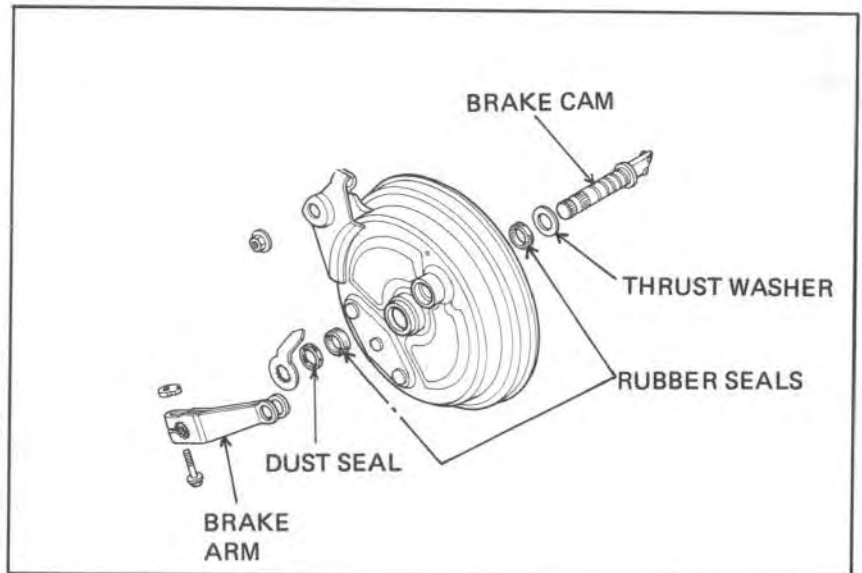

**BRAKE PANEL ASSEMBLY**

Install the new rubber and dust seals.  
Apply grease to the brake camshaft.

**WARNING**

- *A contaminated brake lining reduces stopping power.*
- *Keep grease off the linings. Wipe excess grease off the cam.*

Install the brake cam and thrust washer.  
Install the brake arm and indicator.

**NOTE**

Align the brake cam and brake arm punch marks.

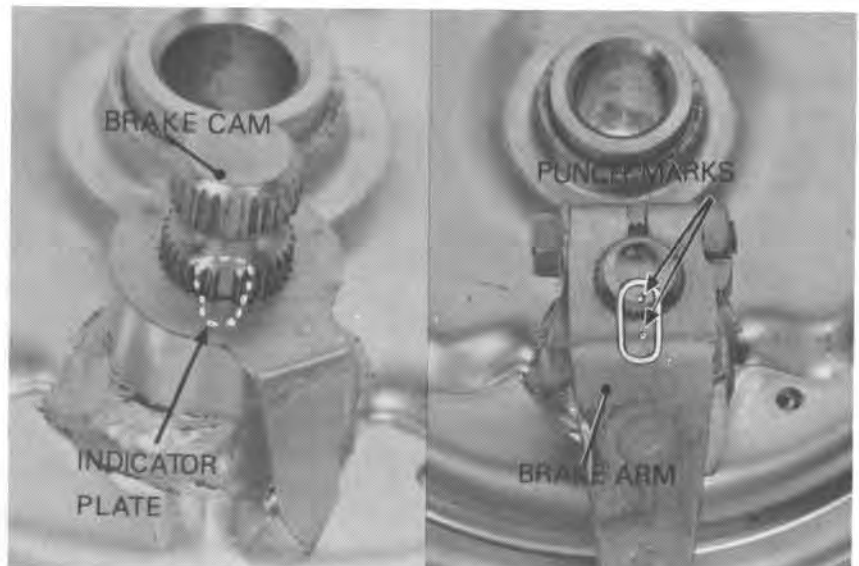



**FRONT WHEEL/BRAKE/STEERING**

**STEERING STEM AND  
FRONT FORK**

**FORK TOP BRIDGE REMOVAL**

Remove the headlight and headlight case bracket (Page 11-3).

Remove the handlebar (Page 11-4).  
Remove the front wheel (Page 11-8).  
Remove the front fender.



Remove the steering stem nut.  
Remove the front fork top bridge bolts.  
Remove the fork top bridge.



**FRONT FORK REMOVAL**

Remove the steering top thread nut.

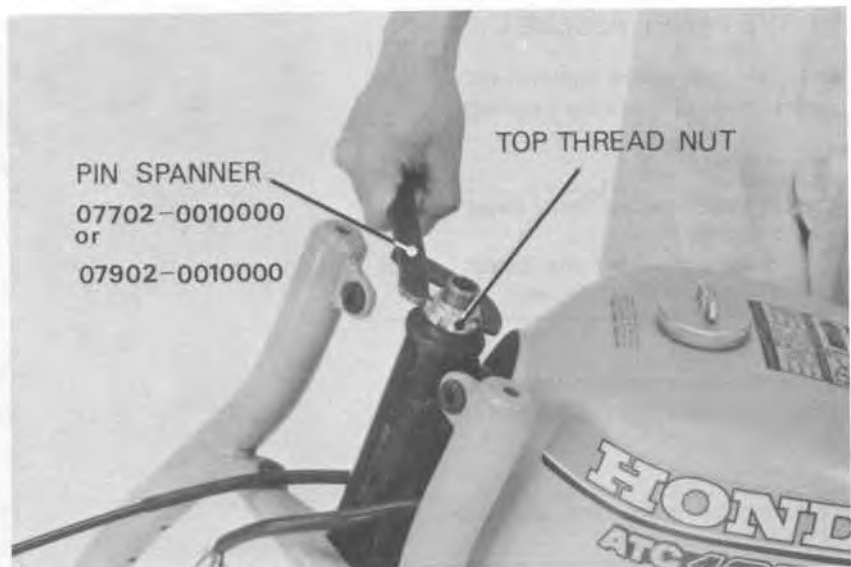



Remove the front fork and bearings.

**NOTE**

Do not allow the steel balls to fall.

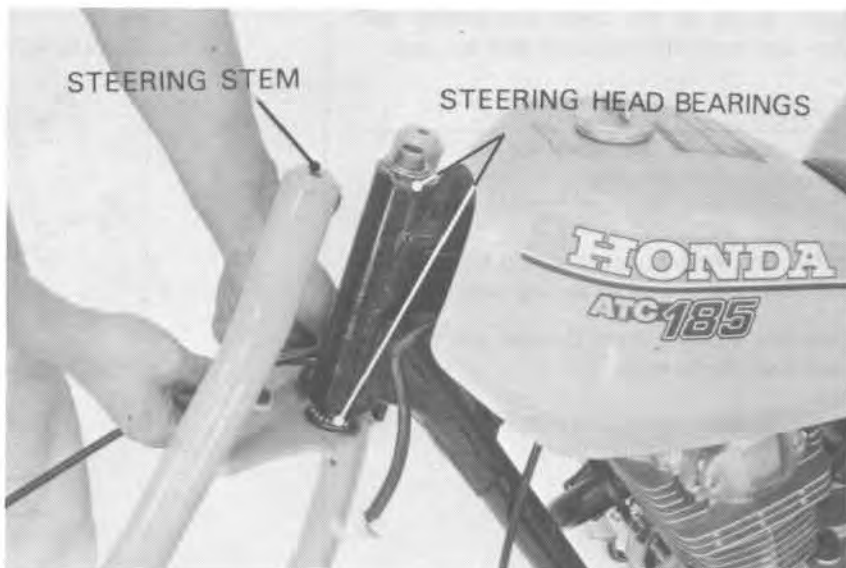

Remove the ball races.  
Check the ball race for wear or damage and  
replace if necessary.



**STEERING STEM INSTALLATION**

Drive in the ball races with a ball race driver.





**FRONT WHEEL/BRAKE/STEERING**

Apply grease to the upper and bottom ball races and install the steel balls and the races.

**NOTE**

21 steel balls are used for both the upper and lower races.

Install the washer, dust seal and bottom race and steel balls onto the steering stem.

Slide the steering stem through the steering head from the bottom.

Install the top race and steel balls. Thread on the top thread nut.

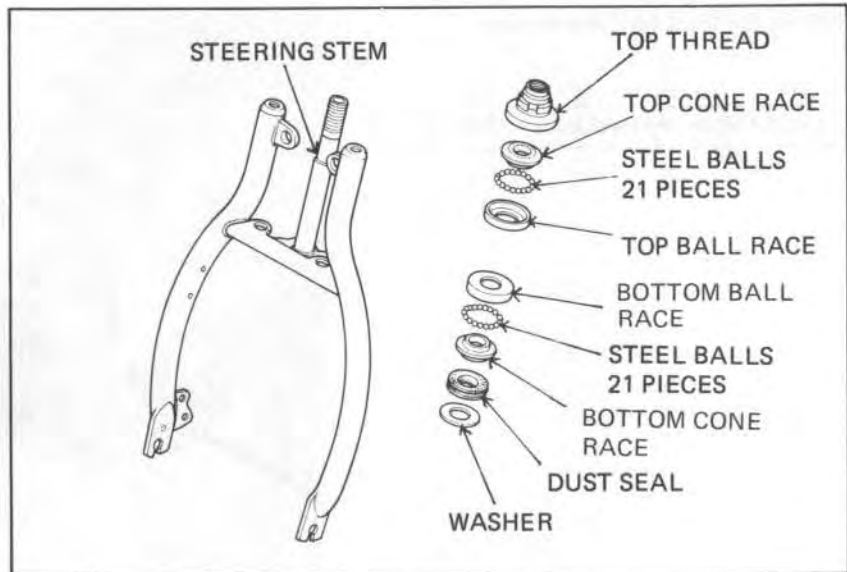

Tighten the top thread nut until snug against the top ball race and back off about 1/8 turn.

Check that the stem rotates freely without axial play.



**TOP BRIDGE INSTALLATION**

Attach the handlebar lower holders loosely to the top bridge.

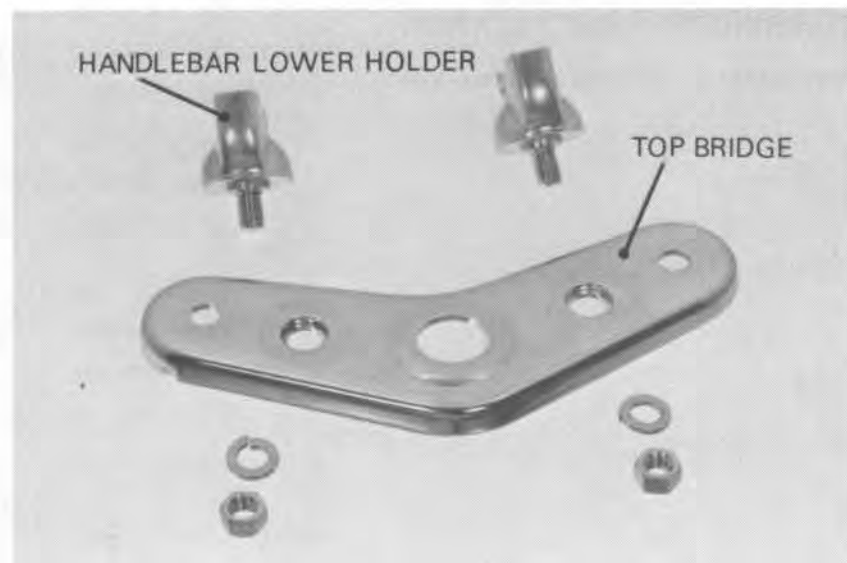



Install the fork top bridge.  
Tighten the steering stem nut.

**TORQUE: 5.0–7.0 kg-m (36–51 ft-lb)**

Tighten the fork bolt.

**TORQUE: 4.0–4.8 kg-m (29–35 ft-lb)**



Install the handlebar (Page 11–4).  
Tighten the handlebar lower holder nuts.

**TORQUE: 4.0–4.8 kg-m (29–35 ft-lb)**

Install the front fender.  
Install the headlight case bracket.  
Install the headlight.



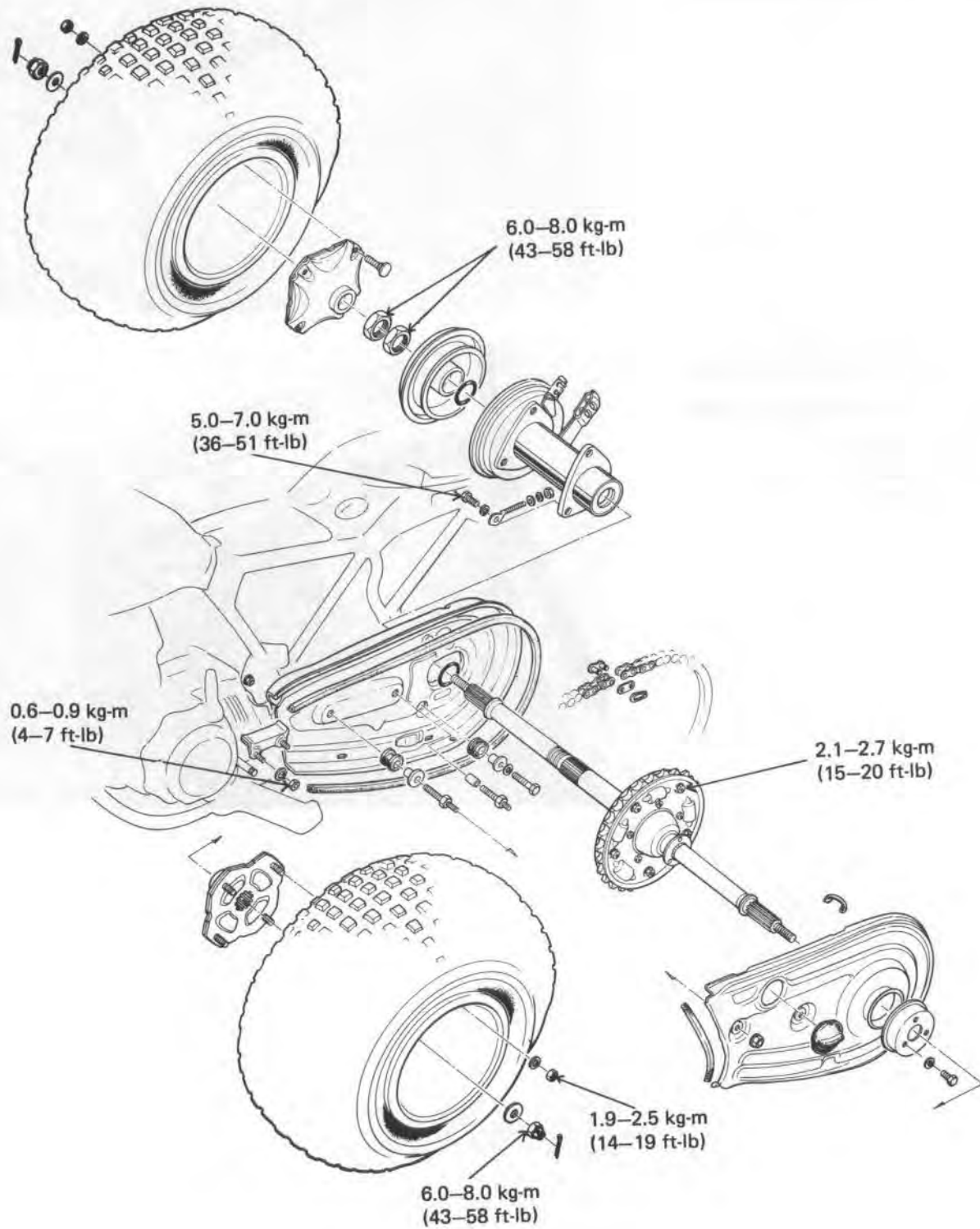





SERVICE INFORMATION	12-1
TROUBLESHOOTING	12-2
REAR WHEEL	12-3
REAR AXLE/FINAL DRIVEN SPROCKET	12-4
REAR AXLE BEARING HOLDER/REAR BRAKE	12-7

## SERVICE INFORMATION

### GENERAL INSTRUCTIONS

- This section covers maintenance of the rear wheel and drive mechanism.
- A jack or block is required to support the ATC.

### TOOLS

#### Common

Bearing Driver Outer 62 x 68 mm	07746-0040800 or 07945-3710300
Driver Handle Outer A	07749-0010000
Driver Pilot 35 mm	07746-0040800

#### Special

41 mm Spanner	07916-9180000 or commercially available 41 mm wrench
Tire Disassembling Tool	07772-0010000 or M987X-350-XXXX (Available in USA only)

### TORQUE VALUES

Rear wheel rim nut	1.9-2.5 kg-m (14-19 ft-lb)
Damper holder nut	2.1-2.7 kg-m (15-20 ft-lb)
Rear brake drum nut	6.0-8.0 kg-m (43-58 ft-lb)
Rear wheel hub nut	1.9-2.5 kg-m (14-19 ft-lb)
Rear wheel nut	6.0-8.0 kg-m (43-58 ft-lb)
Rear axle bearing holder bolt	5.0-7.0 kg-m (36-51 ft-lb)
Drive chain slider nut	0.6-0.9 kg-m (4-7 ft-lb)

### SPECIFICATIONS

ITEM	STANDARD	SERVICE LIMIT
Rear axle runout	—————	3.0 mm (0.12 in)
Rear brake drum I. D.	140 mm (5.5 in)	141 mm (5.6 in)
Rear brake lining thickness	4 mm (0.2 in)	2 mm (0.1 in)
Rear wheel bearing play	Radial	0.05 mm (0.002 in)
	Axial	0.10 mm (0.004 in)



## TROUBLESHOOTING

### Wobble or vibration in motorcycle

1. Bent rim
2. Loose wheel bearing
3. Faulty rear axle bearing holder
4. Faulty tire
5. Axle not tightened properly

### Poor brake performance

1. Improper brake adjustment
2. Worn brake shoes
3. Brake linings oily, greasy or dirty
4. Worn brake cam
5. Worn brake drum
6. Brake arm serrations improperly engaged
7. Brake shoes worn at cam contact area



## REAR WHEEL

### REMOVAL

Raise the rear wheels off the ground with a jack or block under the engine.

Remove the rear wheel hub nuts.  
Remove the rear wheels.



### REAR TIRE DISASSEMBLY/ ASSEMBLY

For tire disassembly, assembly and repair, refer to pages 11-10 to 11-13.

#### NOTE

The rear tire has one rim plate located on the inside rim.

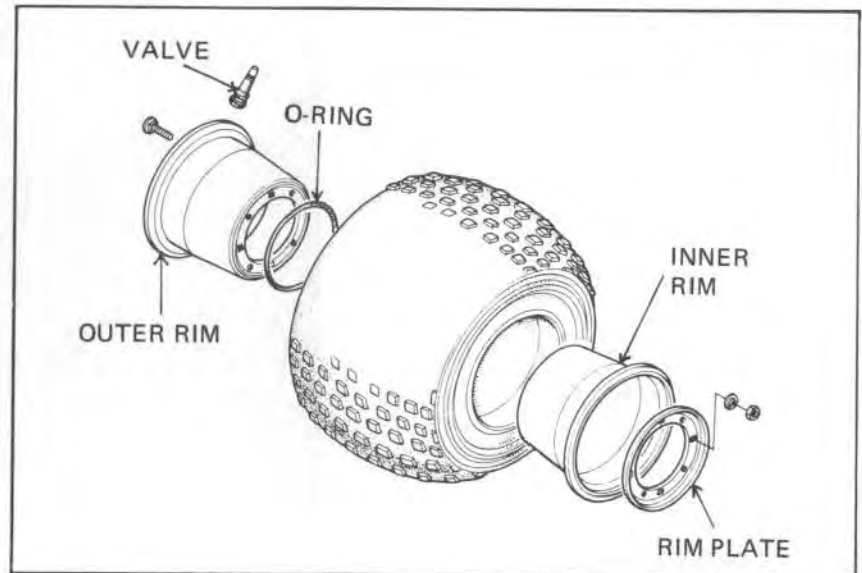

### REAR WHEEL INSTALLATION

Install the rear wheel with the tire valve facing out.

Tighten the hub nuts.

**TORQUE: 1.9-2.5 kg-m (14-19 ft-lb)**



## REAR AXLE/FINAL DRIVEN SPROCKET

### REAR AXLE REMOVAL

Remove the cotter pins and remove the rear wheel hubs.

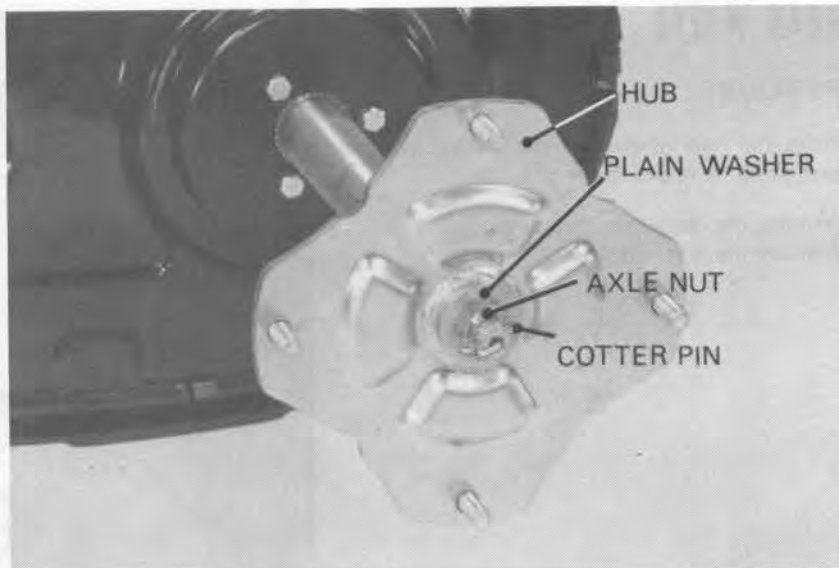

Remove the seat and rear fenders.  
Remove the frame under cover.

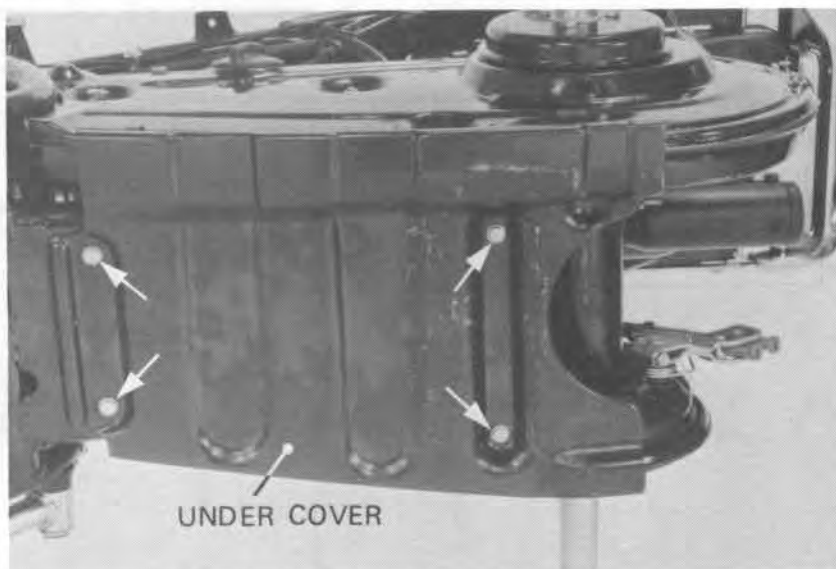

Remove the sealed cover.  
Pull off the chain cover clips.

Remove the drive sprocket cover.  
Remove the drive chain cover.

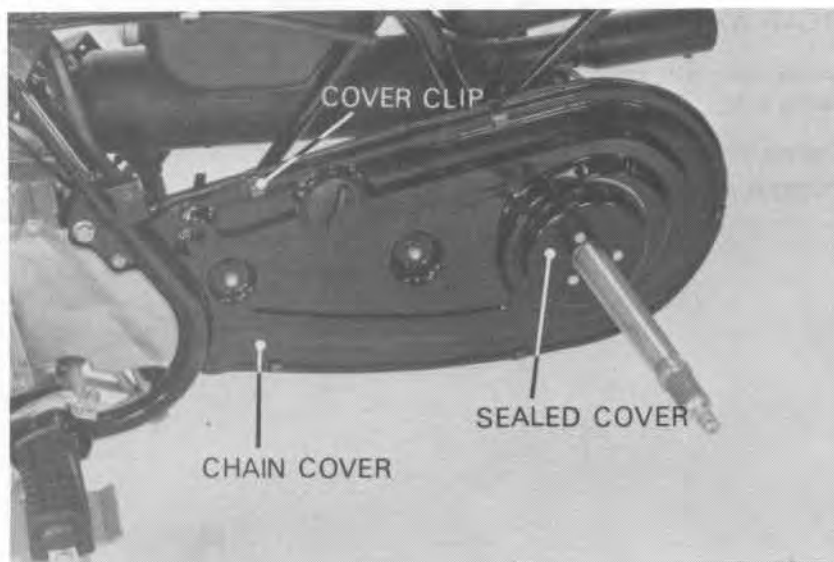



Loosen the bearing holder bolts and drive chain adjuster (Page 3-9).

Remove the chain clip.  
Remove the master link and drive chain.



Apply the parking brake.  
Remove the brake drum nuts.

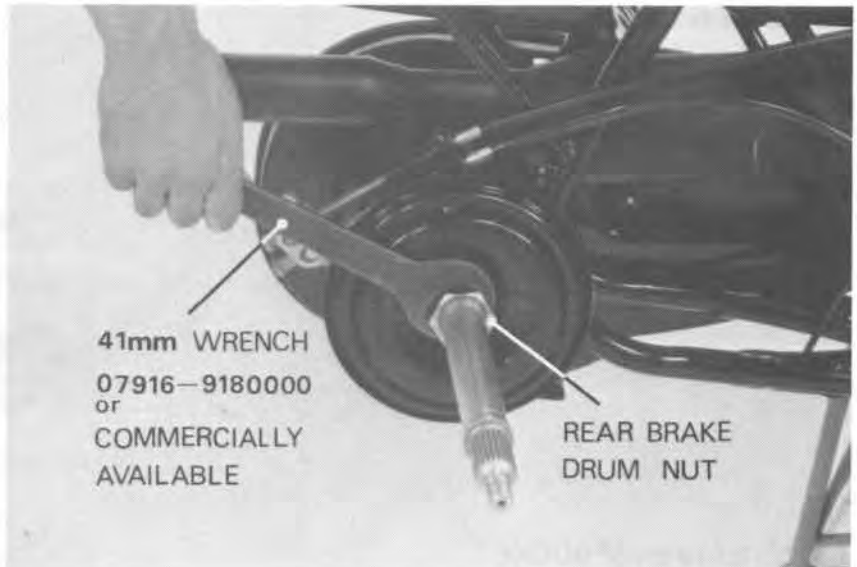

Release the parking brake.  
Pull the rear axle out of the frame.

Remove the brake drum from the bearing holder.

Remove the chain case and chain slider.

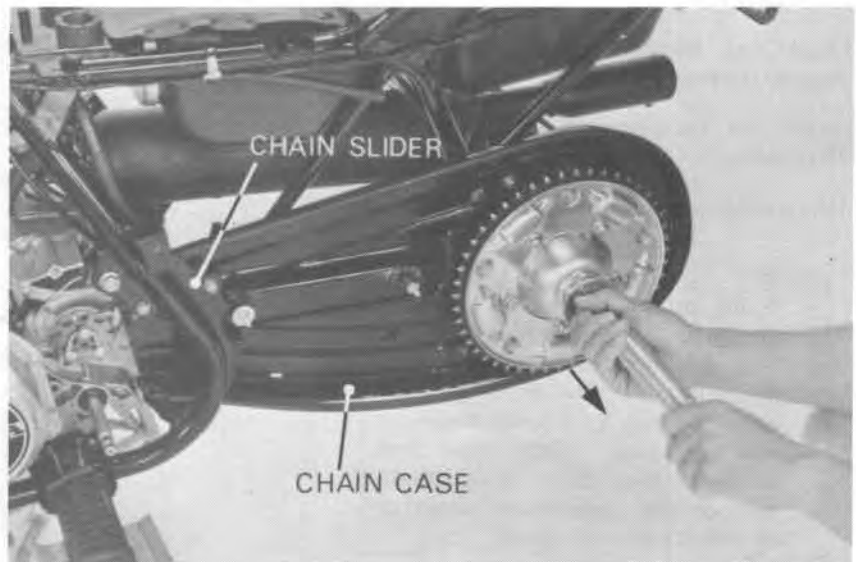



Remove the driven flange bolts.



Remove the damper holder bolts.  
Remove the damper holders.  
Remove the damper rubbers.

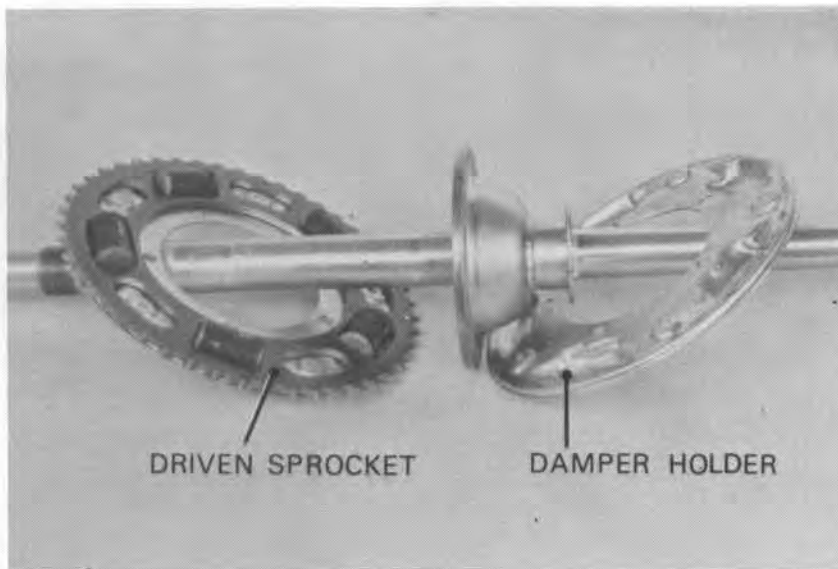

**FINAL DRIVEN SPROCKET  
INSPECTION**

Check the damper rubbers for damage.  
Replace if necessary.

Check the condition of the final driven  
sprocket teeth.

Replace the sprocket if it is worn or damaged.

**NOTE**

- If the driven sprocket is worn or damaged, the drive chain and the drive sprocket must be inspected.
- Never install a new drive chain on worn sprocket or a worn chain on new sprocket. Both chain and sprockets must be in good condition or the replacement chain or sprockets will wear rapidly.

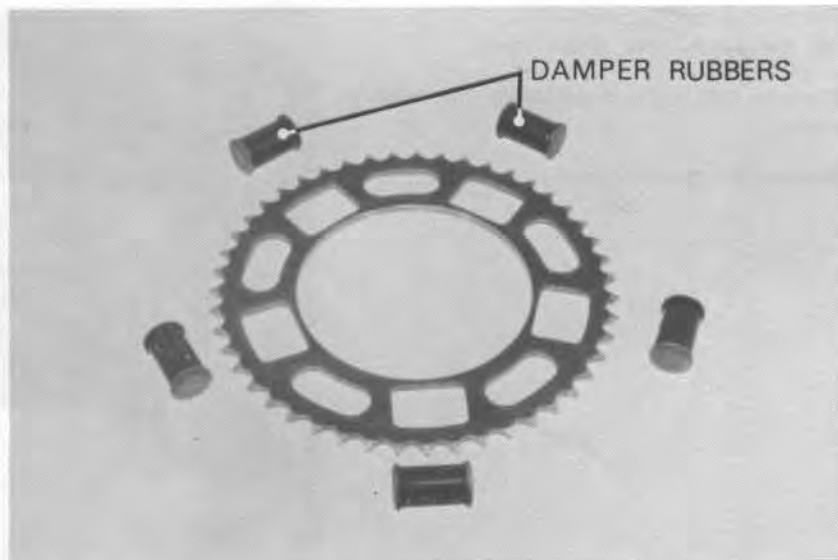



**AXLE INSPECTION**

Place the rear axle in V-blocks and measure the runout.

The actual runout is 1/2 of the Total Indicator Reading.

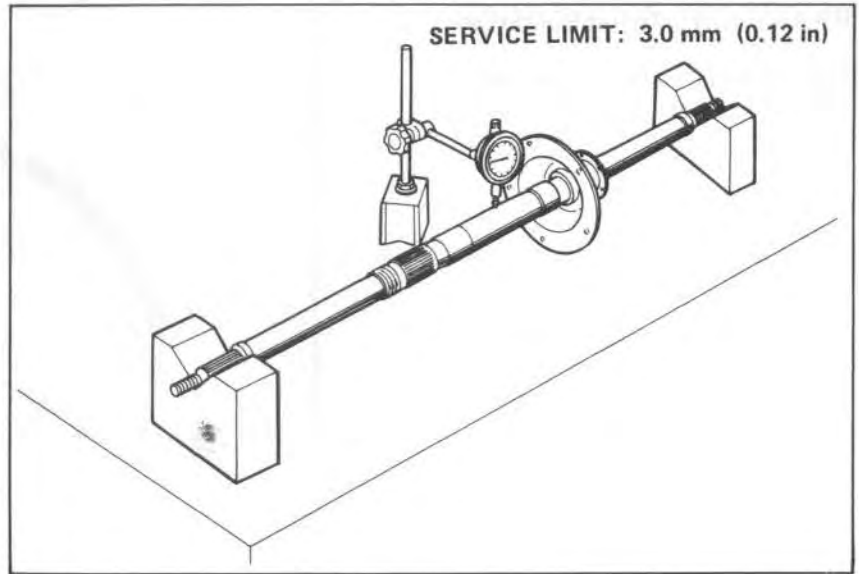

**REAR AXLE BEARING HOLDER/  
REAR BRAKE**

**REAR WHEEL BEARING HOLDER  
REMOVAL**

Disconnect the rear brake cables from the rear brake arm.

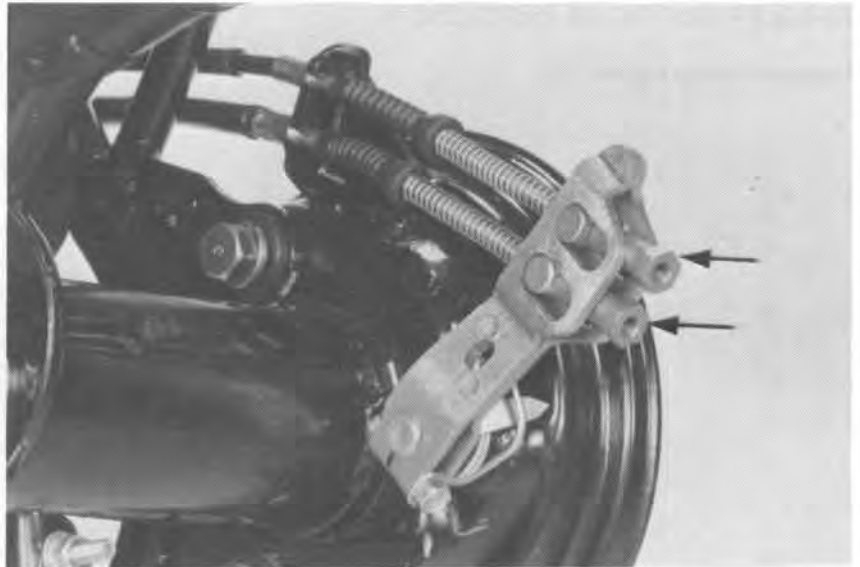

Remove the bolts and rear wheel bearing holder.



**REAR WHEEL/  
BRAKE/DRIVE MECHANISM**



**HONDA  
ATC185**

**BRAKE LINING INSPECTION**

Measure the brake lining thickness.

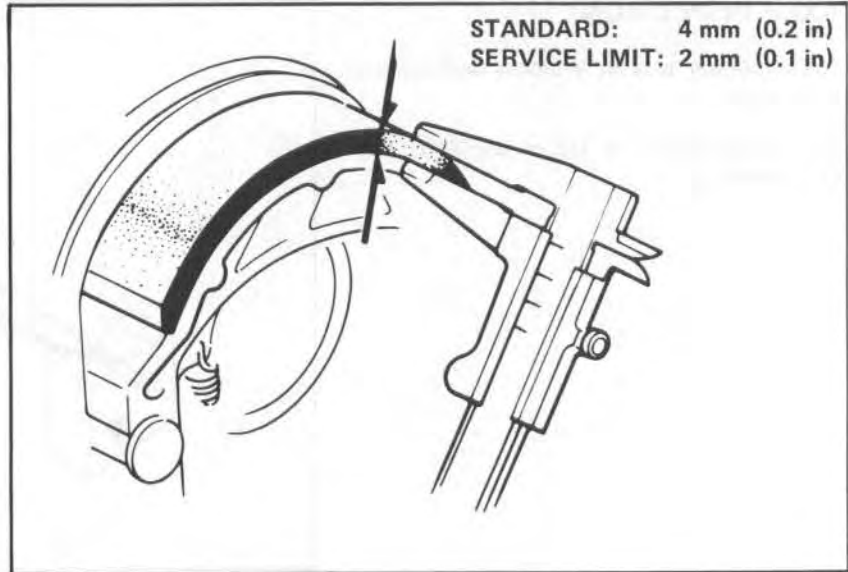

**REAR BRAKE DRUM INSPECTION**

Measure the brake drum I. D.

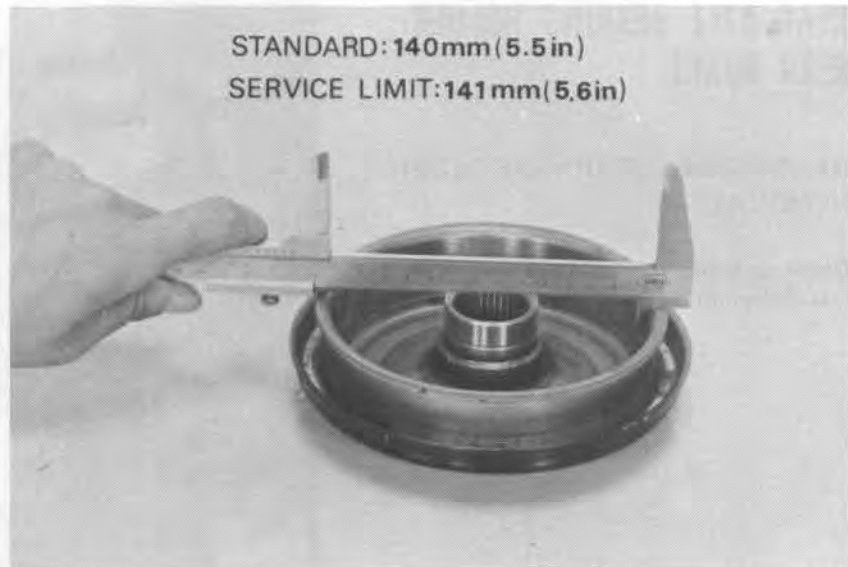

**REAR BRAKE DISASSEMBLY**

Expand and remove the brake shoes by hand.

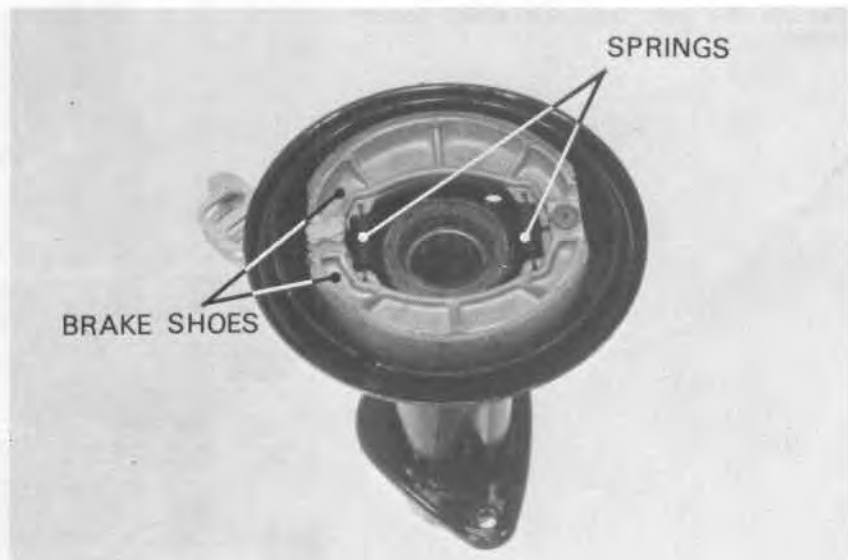





Remove the brake arm bolt and brake arm.  
Remove the return spring and indicator plate.  
Remove the brake cam.

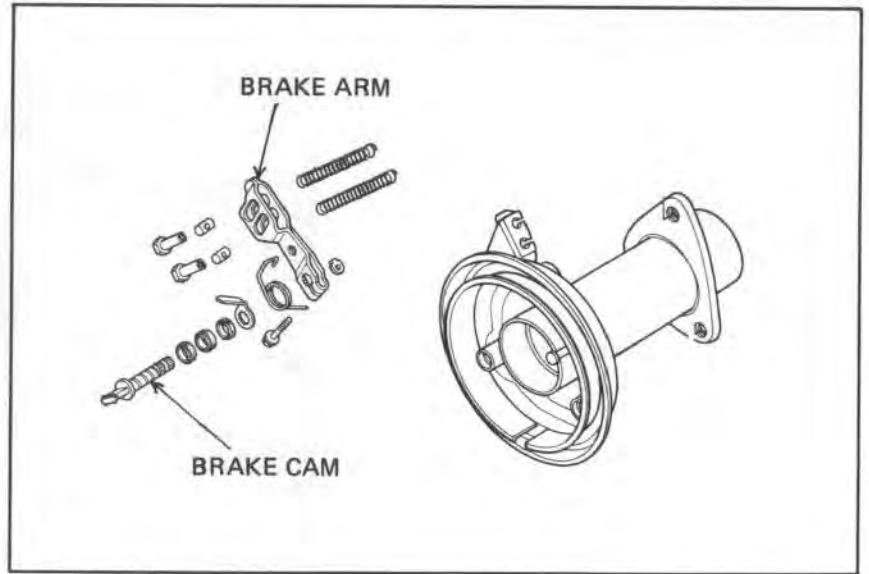

**REAR WHEEL BEARING HOLDER  
DISASSEMBLY**

Remove the dust seals.  
Remove the O-rings.  
Drive out the bearings and center collar.

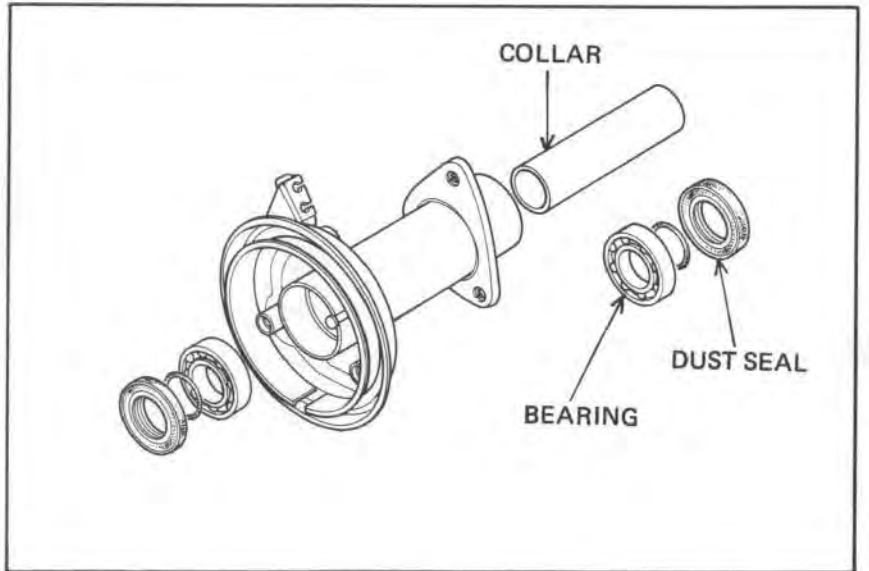

**REAR WHEEL BEARING  
INSPECTION**

Check the rear wheel bearings. Replace the bearings if they are noisy or have excessive play.

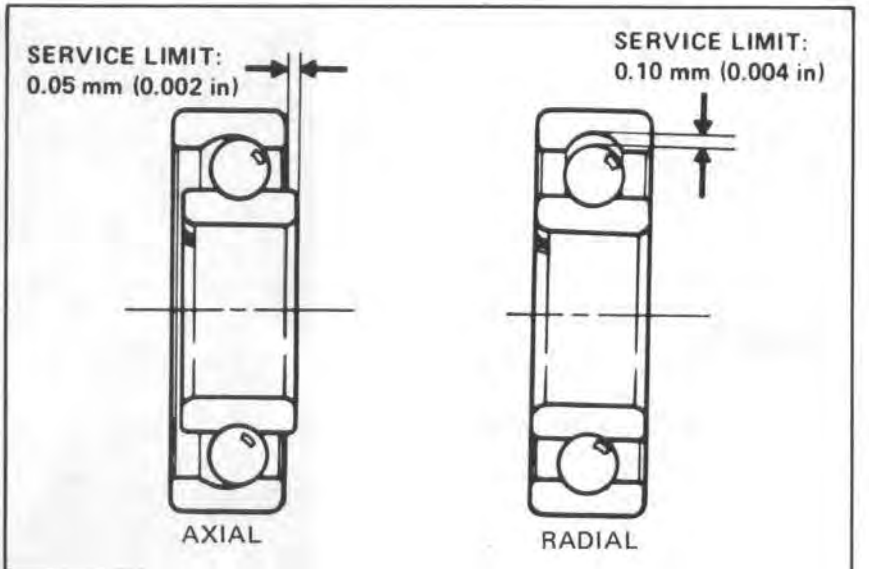

## REAR WHEEL/ BRAKE/DRIVE MECHANISM



**HONDA**  
**ATC185**

### REAR WHEEL BEARING HOLDER ASSEMBLY

Pack the bearing cavities with grease.  
Drive the right bearing into the bearing holder.

Install the center collar.  
Drive the left bearing in.

#### NOTE

- Drive the bearings squarely.
- Install the bearings with the mark facing out.



Coat the dust seal lips with grease and install the dust seals.



Apply grease to the brake cam's shaft.  
Install the dust seal.  
Install the wear indicator plate.

Install the brake arm on the brake cam,  
aligning the punch marks.  
Tighten the brake arm bolt.

Install the brake shoes on the brake panel.

#### WARNING

- Contaminated brake linings reduce stopping power.
- Keep grease off the linings. Wipe excess grease off the cam.

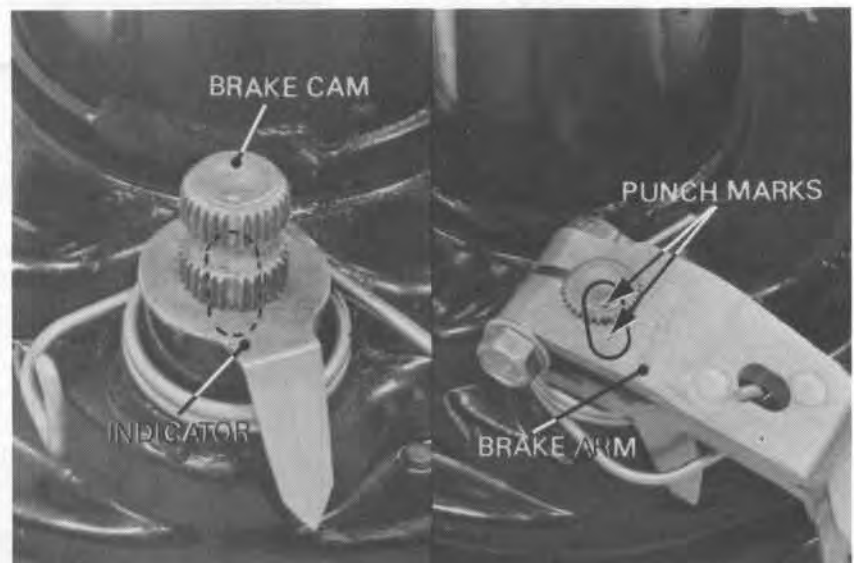



Install the rear bearing holder and drive chain adjuster.

Tighten the rear wheel hub attaching bolts loosely.

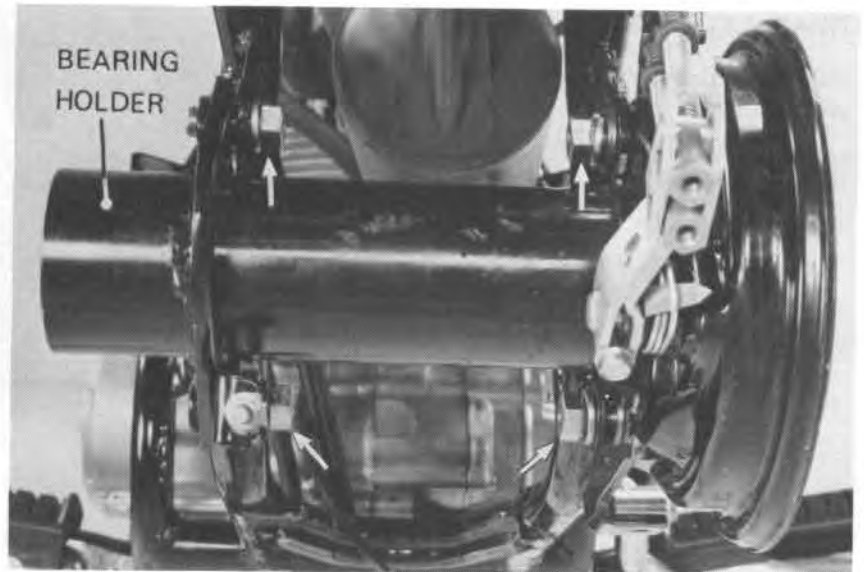

**FINAL DRIVEN FLANGE ASSEMBLY**

Install the damper rubbers onto the driven sprocket.



Apply grease to the final driven sprocket.

Install the damper holders.

Tighten the damper holder bolts.

**TORQUE: 2.1–2.7 kg-m (15–20 ft-lb)**

Install the final driven flange onto the rear axle.

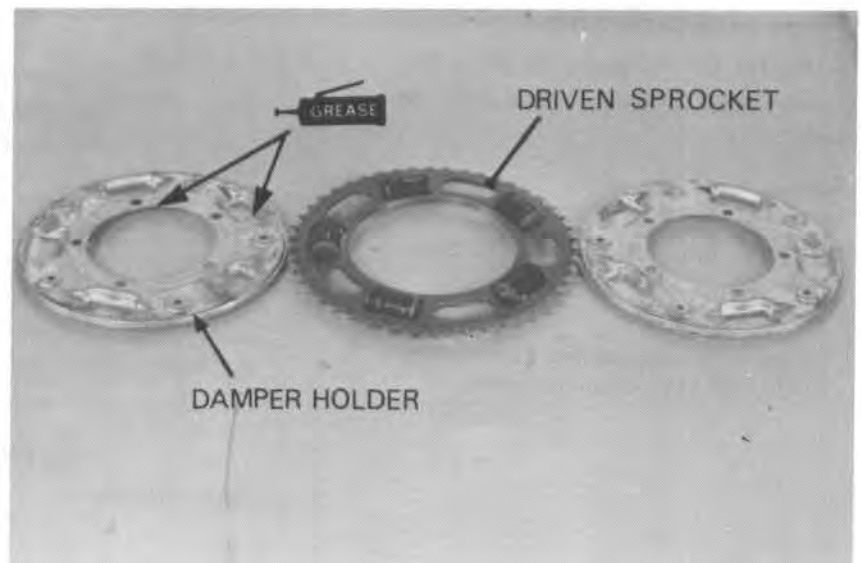

## REAR WHEEL/ BRAKE/DRIVE MECHANISM



**HONDA**  
**ATC185**

### REAR AXLE INSTALLATION

Make sure the chain case rubber seal is in good condition.

Install the rubber seal onto the chain case.  
Install the chain case and chain slider.

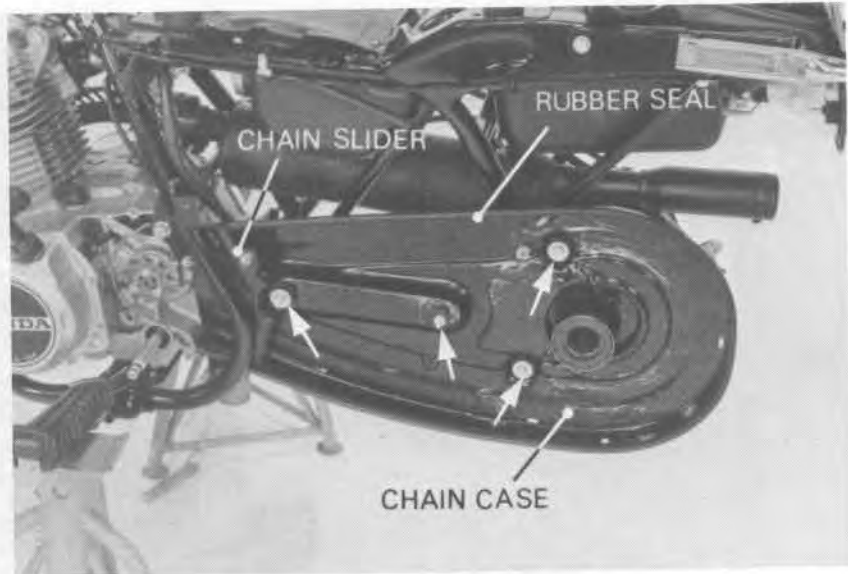

Coat the O-rings with grease.  
Install the O-ring onto the axle.  
Install the rear axle from the left side.

Install the other O-ring onto the axle.  
Install the rear brake drum.  
Screw in the rear brake drum nuts by hand.

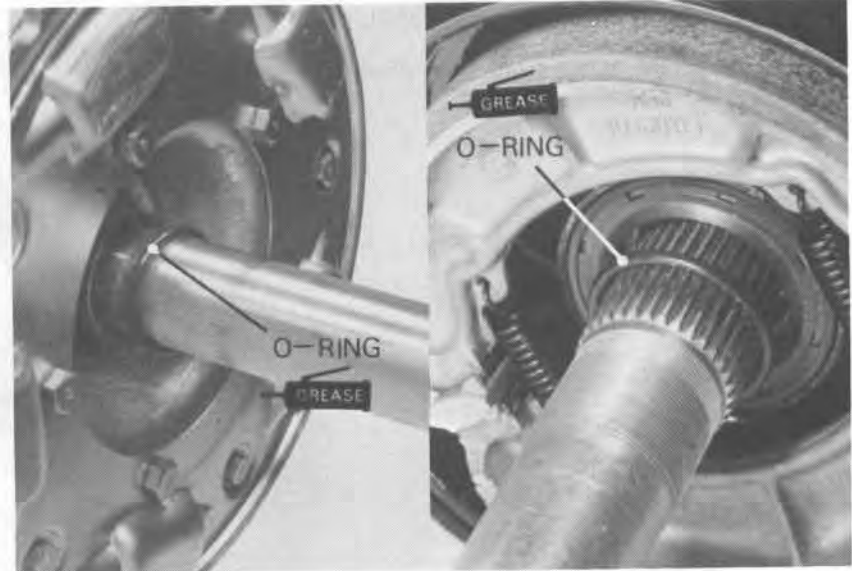

Tighten the brake drum nuts.

**TORQUE: 6.0–8.0 kg-m (43–58 ft-lb)**

Apply **LOCKTITE®** or equivalent to the shaft.

Tighten the brake drum outer nut with a spanner at the inner nut.

**TORQUE: 6.0–8.0 kg-m (43–58 ft-lb)**

#### NOTE

Wipe grease off the shaft before applying **LOCKTITE®** or equivalent.

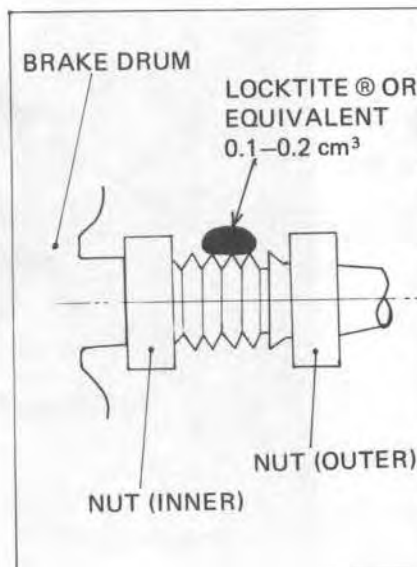



Install and connect the drive chain with the master link.  
Install the clip in the direction shown.

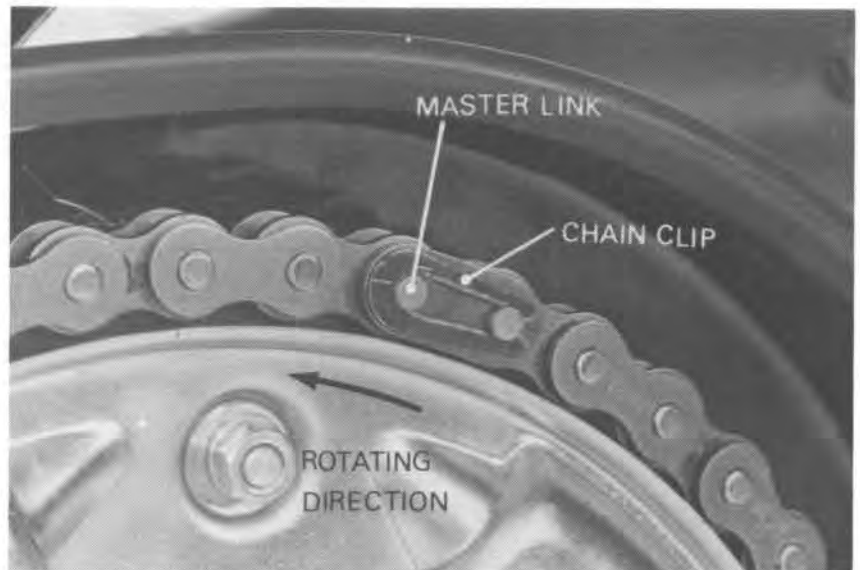

Adjust the drive chain (Page 3-00).  
Tighten the bearing holder attaching bolts.

**TORQUE: 5.0-7.0 kg-m (31-51 ft-lb)**

Install the chain cover rubber seal.  
Install the chain cover.  
Install the frame lower cover.



Coat the axle with grease.  
Install the rear wheel hubs.  
Tighten the rear axle nuts.

**TORQUE: 6.0-8.0 kg-m (43-58 ft-lb)**

Install the cotter pins and bend the ends.  
Install the rear wheel (Page 12-3).

Connect the rear brake cables and adjust the rear brake (Page 3-12).

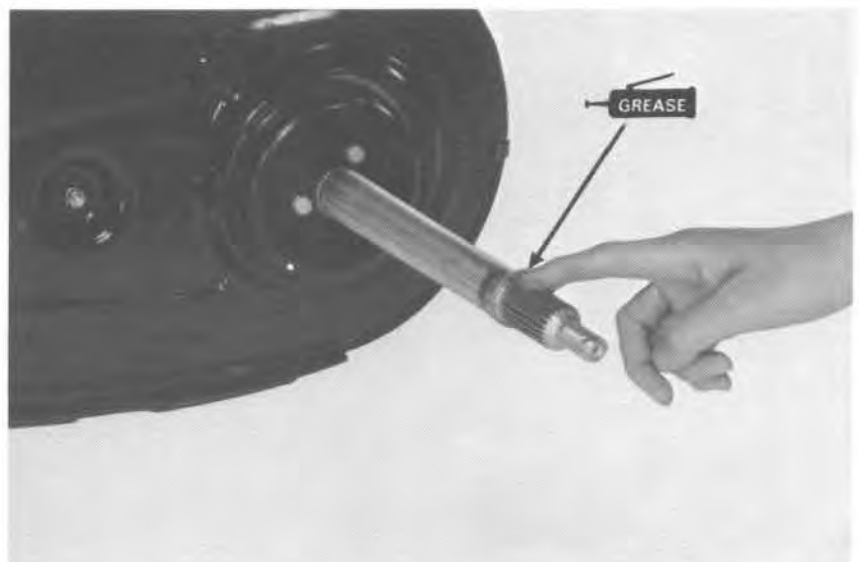



**MEMO**

... ..  
... ..  
... ..

... ..  
... ..  
... ..  
... ..  
... ..

... ..  
... ..  
... ..  
... ..  
... ..



REAR FENDER  
EXHAUST PIPE

13-1

13-2

## REAR FENDER

### REAR FENDER REMOVAL

Remove the seat.

Remove the rear fenders.

Remove the screws and mud guards.

Remove the rear fender stays.

### REAR FENDER INSTALLATION

The installation sequence is the reverse order of removal.

#### NOTE

Be sure to include the collar with the fender bolts.

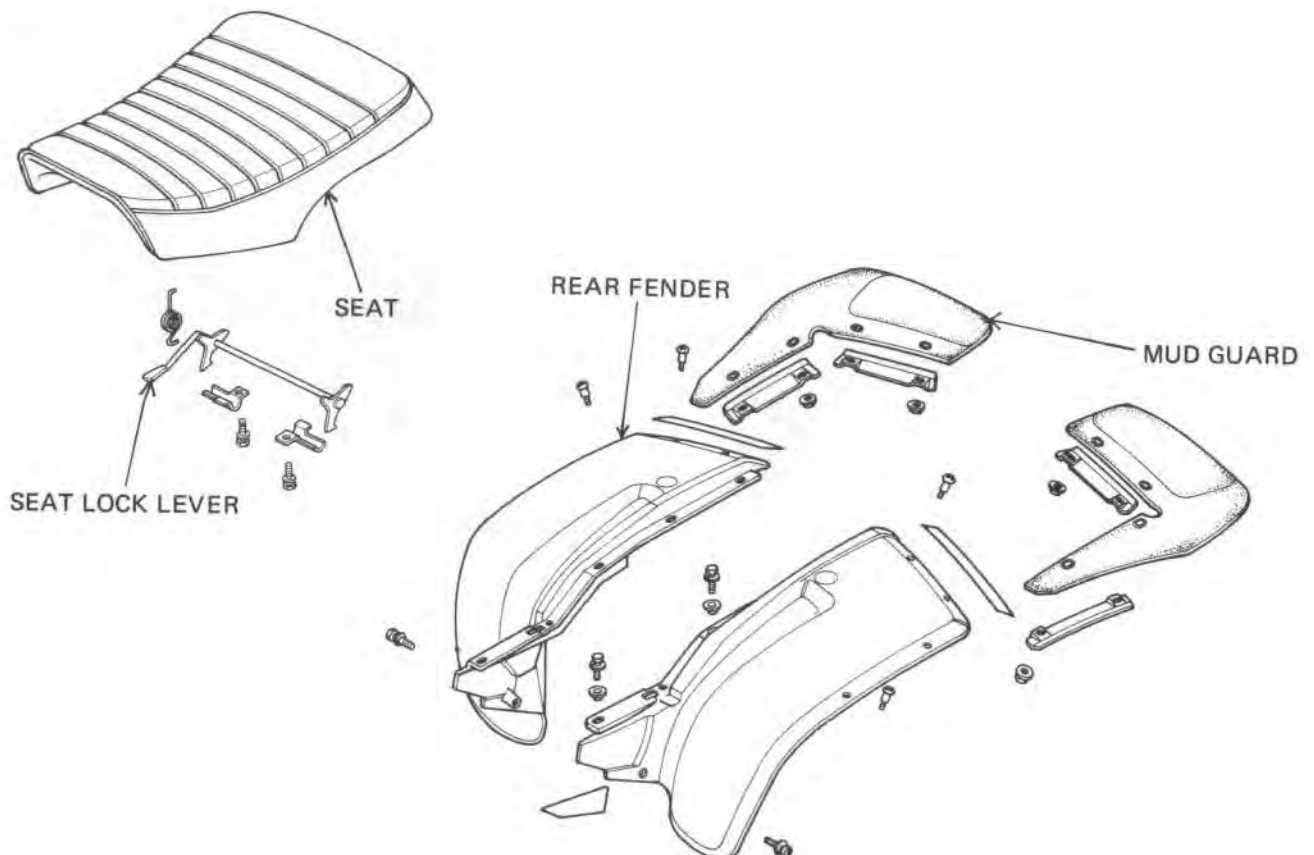



## EXHAUST PIPE

Refer to Page 3-16 for spark arrester cleaning.

### WARNING

*Do not service the exhaust pipe or muffler while they are hot.*

### EXHAUST PIPE REMOVAL

Remove the seat.

Remove the right rear fender.

Loosen the exhaust pipe band.

Remove the exhaust pipe joint nuts and exhaust pipe.

Remove the muffler mounting bolts and muffler.

### NOTE

Check the gasket and pipe seal for wear.  
Replace with a new one if necessary.

### EXHAUST PIPE INSTALLATION

The installation sequence is essentially the reverse of removal.

### NOTE

After installing, make sure that there are no exhaust leaks.

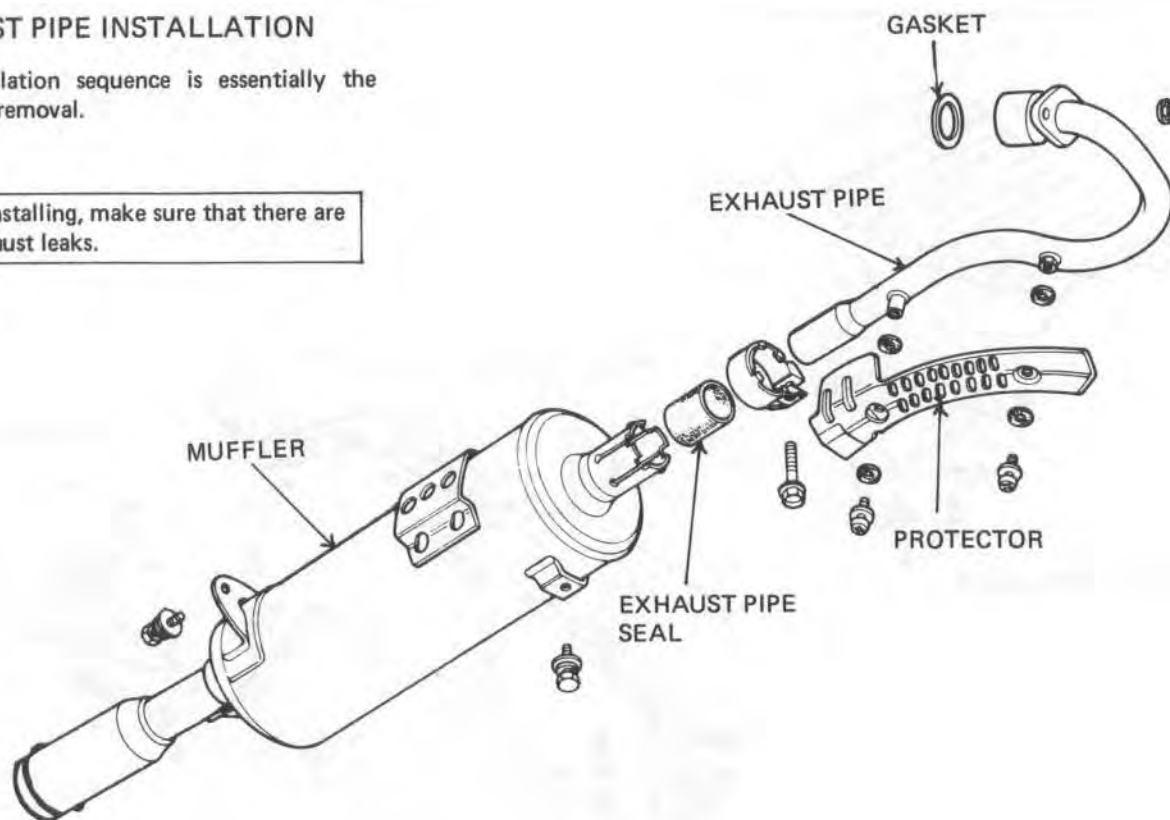





**HONDA**  
**ATC185**

---

MEMO



**IGNITION SYSTEM**

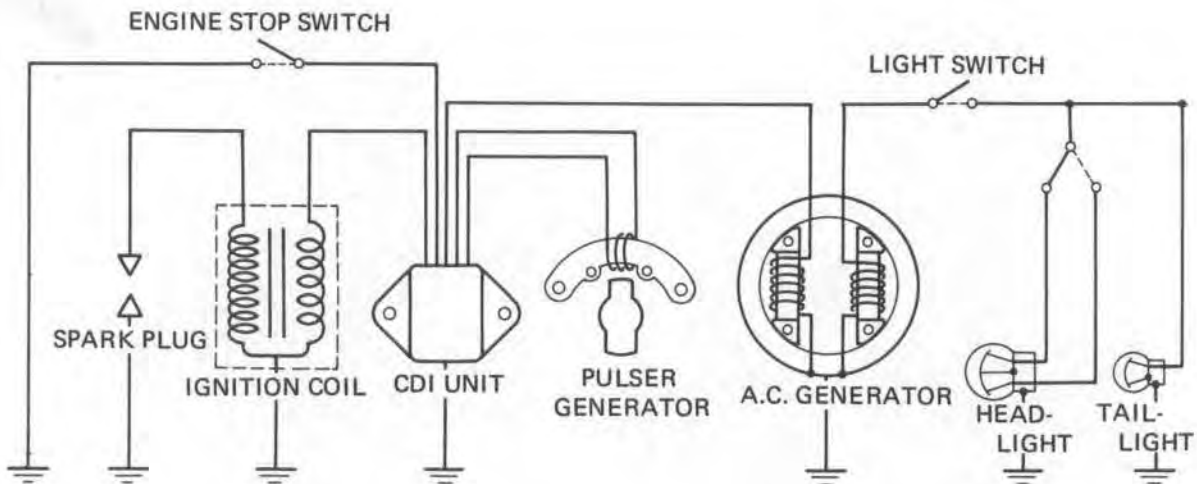
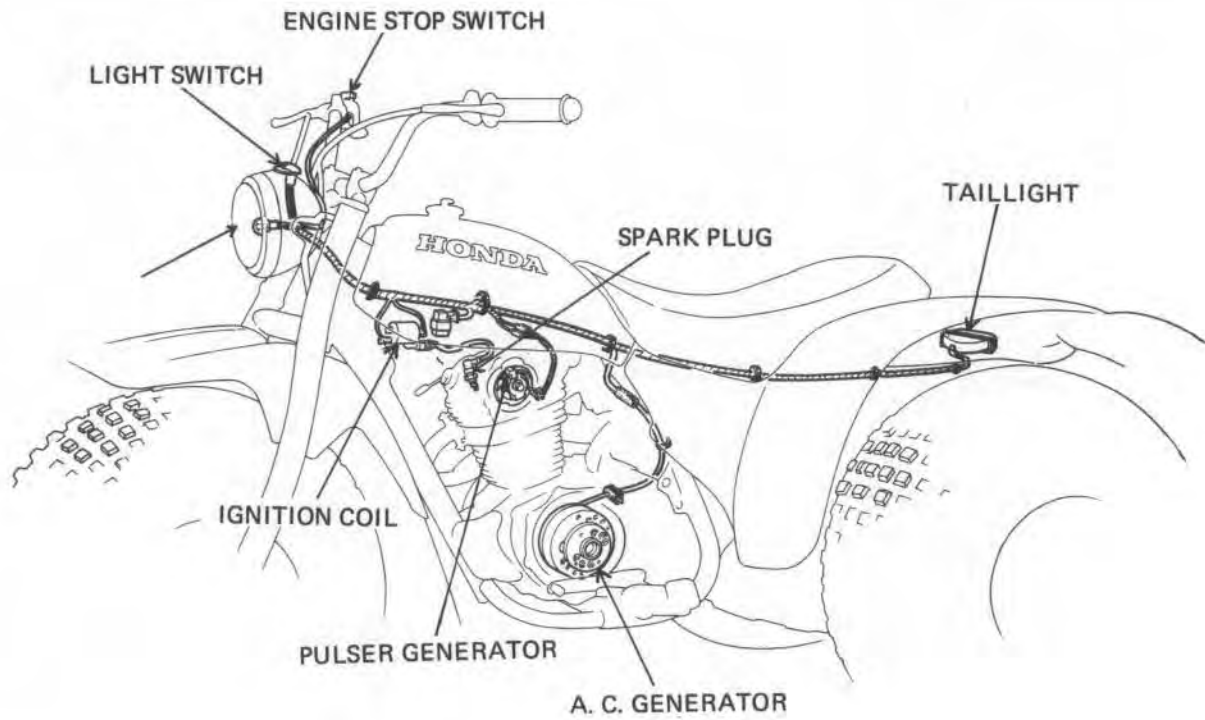



SERVICE INFORMATION	14-1
TROUBLESHOOTING	14-1
IGNITION COIL	14-2
A.C. GENERATOR	14-2
CDI UNIT	14-3
PULSER GENERATOR	14-4
IGNITION TIMING	14-4

## SERVICE INFORMATION

### GENERAL INSTRUCTIONS

- Ignition timing does not normally need to be adjusted since the CDI (Capacitive Discharge Ignition) unit is factory pre-set.
- For spark plug inspection, refer to Page 3-4.
- For pulser generator removal, see Page 6-4.

### SPECIFICATIONS

Spark plug	
USA Model	Canada model
X24ES-U (ND)	X24ESR-U (ND)
D8EA (NGK)	DR8ES-L (NGK)
Spark plug gap	0.6–0.7 mm (0.024–0.028 in)
Ignition timing:	
Initial	10° ± 2° BTDC/1,400 ± 100 rpm
Advance start	1950 ± 150 rpm
Full advance	30° ± 2° BTDC/3,350 ± 150 rpm
A. C. generator	50W/5,000 rpm
	11V at 3,000 rpm
	15V at 10,000 rpm

## TROUBLESHOOTING

### Engine starts but stops

1. No spark at plug
2. Improper ignition timing
3. Faulty spark plug

### No spark at plug

1. Engine stop switch "OFF"
2. Poorly connected, broken or shorted wires
  - Between A.C. generator and ignition coil
  - Between CDI unit and engine stop switch
  - Between CDI unit and ignition coil
  - Between ignition coil and spark plug
  - Between pulser generator and CDI unit
3. Faulty ignition coil
4. Faulty CDI unit
5. Faulty pulser generator
6. Faulty A.C. generator

### Engine starts but runs poorly

1. Ignition primary circuit
  - Faulty ignition coil
  - Loose or bare wire
  - Faulty A.C. generator
2. Ignition secondary circuit
  - Faulty plug
  - Faulty CDI unit
  - Faulty pulser generator
  - Faulty high tension wire
3. Improper ignition timing
  - Faulty advancer rotor
  - Faulty pulser generator
  - Faulty CDI unit



## IGNITION COIL

### IGNITION COIL REMOVAL

Remove the seat and fuel tank.  
Remove the spark plug cap from the spark plug.

Disconnect the wires.  
Remove the ignition coil.

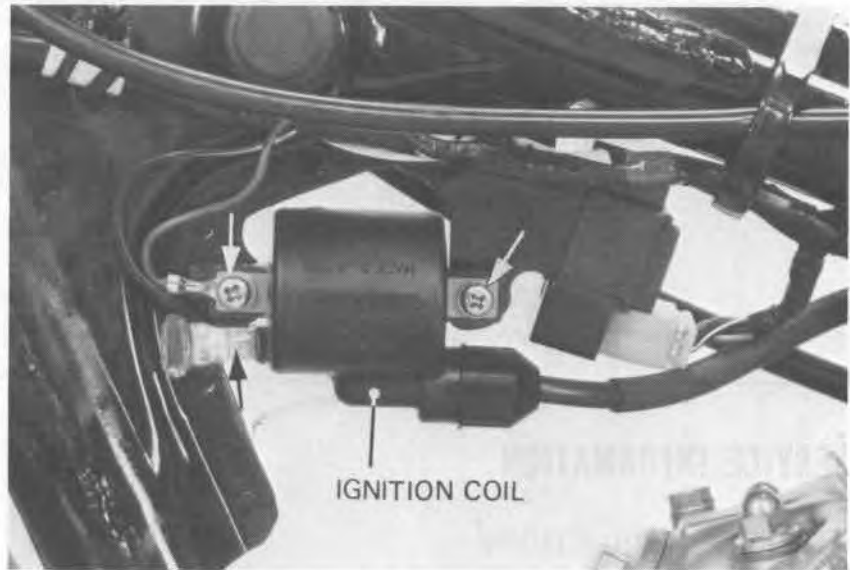

### IGNITION COIL INSPECTION

Check the resistances between the leads of the primary and secondary coils:

Primary coil: 0.2–0.8  $\Omega$

Secondary coil: 8–15 k $\Omega$

### IGNITION COIL INSTALLATION

Install the ignition coil in the reverse order of removal.

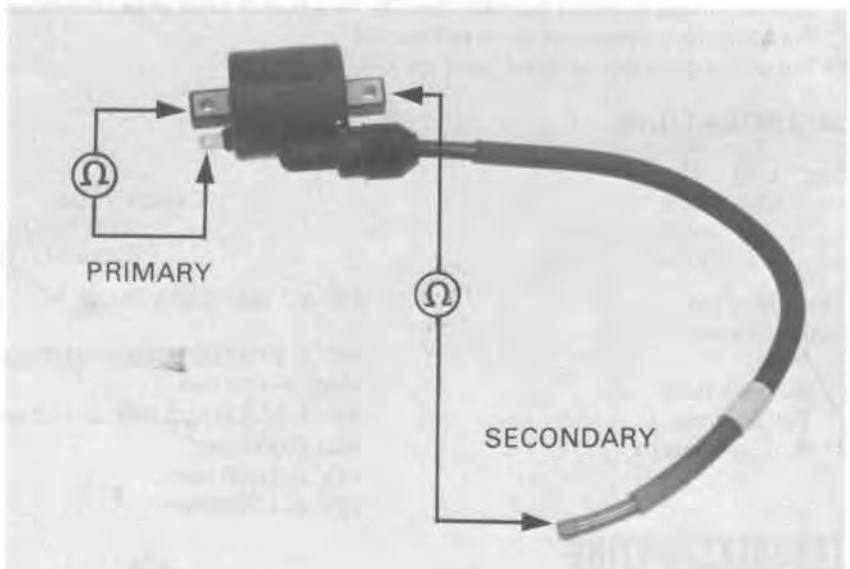

## A.C. GENERATOR

Disconnect the A. C. generator wire coupler and test as follows:

#### NOTE

It is not necessary to remove the stator coil to make this test.

### LIGHTING COIL

The lighting coil is correct if there is continuity between the white/yellow wire and ground.

### EXCITER COIL

The exciter coil is normal if there is continuity between the black/red wire and ground.

**SPECIFIED RESISTANCE: 245  $\Omega$**





## CDI UNIT

### CDI UNIT REMOVAL

Remove the seat and fuel tank.  
Disconnect the wire coupler.  
Remove the CDI unit.

### CDI UNIT INSPECTION

Replace the CDI unit if the readings are within the limits shown in the table.

#### NOTE

- The CDI unit is fully transistorized.
- For accurate testing, it is necessary to use a specified electric tester. Use of an improper tester may give a false reading.
- Use SANWA ELECTRIC TESTER (P/N 7308-0020000) or KOWA ELECTRIC TESTER (TH-5H).

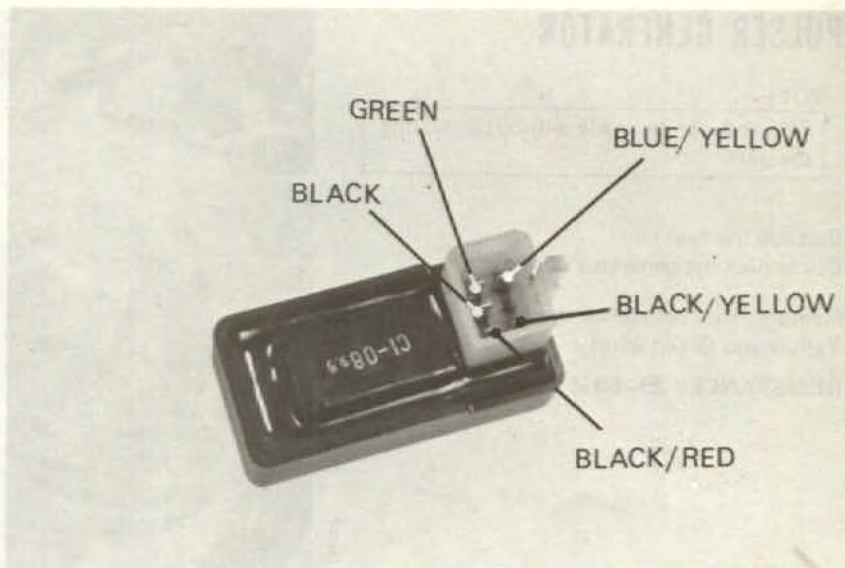

Set the tester on the R x KΩ

Unit: KΩ

(-) \ (+)	BLACK/WHITE (D)	GREEN (B)	BLACK/RED	BLUE/YELLOW	BLACK /YELLOW
BLACK/WHITE (D)		∞	∞	∞	∞
GREEN (B)				∞	∞
BLACK/RED		∞		∞	∞
BLUE/YELLOW					∞
BLACK /YELLOW	∞	∞	∞	∞	



## IGNITION SYSTEM

### PULSER GENERATOR

#### NOTE

This test can be made without removing the part.

Remove the fuel tank.  
Disconnect the generator wires.

Measure the resistance between the Blue/  
Yellow and Green wires.

**RESISTANCE: 20–60 $\Omega$**

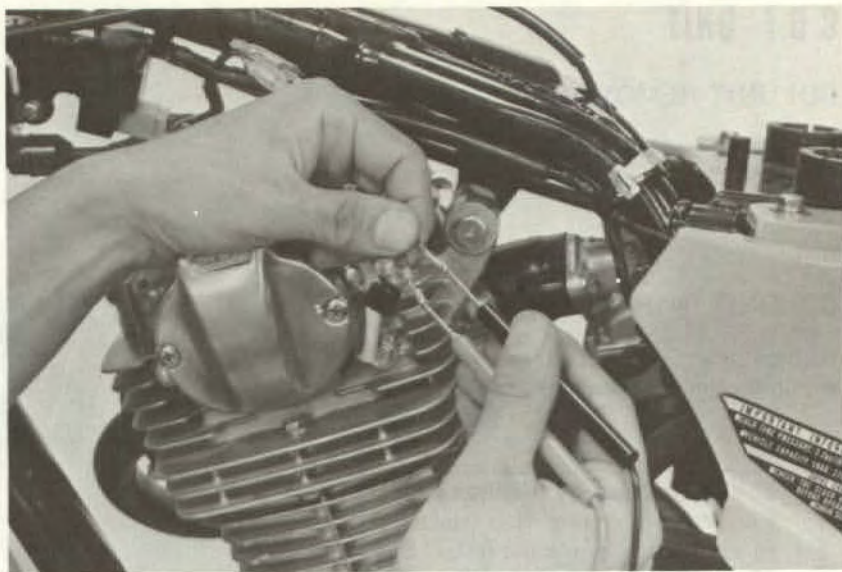

### IGNITION TIMING

Remove the timing hole cap.  
Connect a timing light.  
Start the engine and allow to idle.

**IDLE (1,300 rpm): "F" mark should be aligned with index mark.**

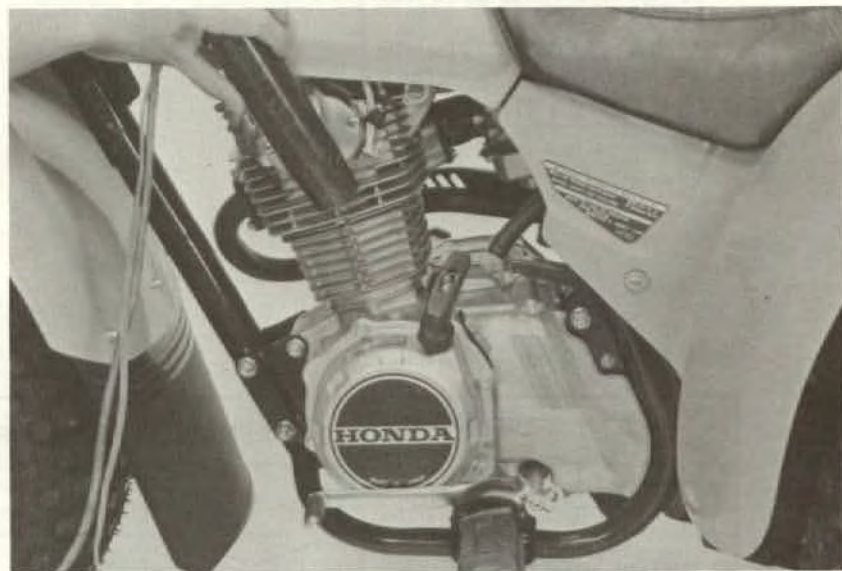

To adjust, remove the pulser generator cover, loosen the base plate attaching screws and turn the plate left or right as required.

If ignition timing cannot be corrected, inspect the CDI unit and pulser generator. Replace any faulty components.

Maintain a pulser rotor-to-generator gap of 0.3–0.4 mm

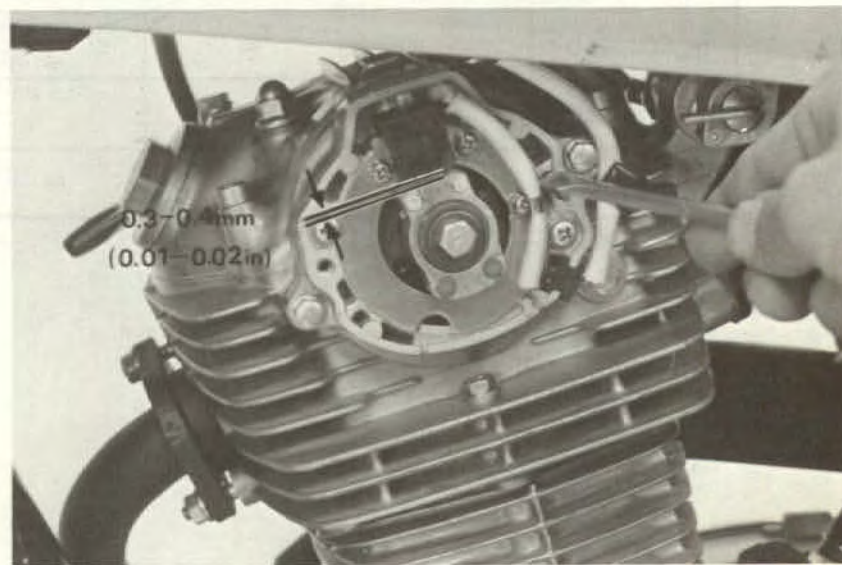



SERVICE INFORMATION	15-1
TROUBLESHOOTING	15-1
HEADLIGHT	15-2
TAILLIGHT	15-2
LIGHT/DIMMER SWITCH	15-3
ENGINE STOP SWITCH	15-3

## SERVICE INFORMATION

### GENERAL INSTRUCTION

A continuity check can usually be made without removing the part from the ATC by simply disconnecting the wires and connecting a continuity tester or voltmeter to the terminals.

### SPECIFICATIONS

Headlight	12V 25/25W
Taillight	12V 5W

## TROUBLESHOOTING

Light does not come on when light switch is turned on (Engine is running)

1. Bulb burned out
2. Faulty switch
3. Wiring to that component has open circuit
4. Faulty lighting coil. (See page 14-2)

Headlight beams do not shift when hi-lo switch is operated

1. Faulty dimmer switch



## HEADLIGHT

### HEADLIGHT DISASSEMBLY

Remove the headlight mounting screw and disconnect the wires.

Remove and disassemble the headlight.

### HEADLIGHT ASSEMBLY

Assemble the headlight in the reverse order of disassembly.

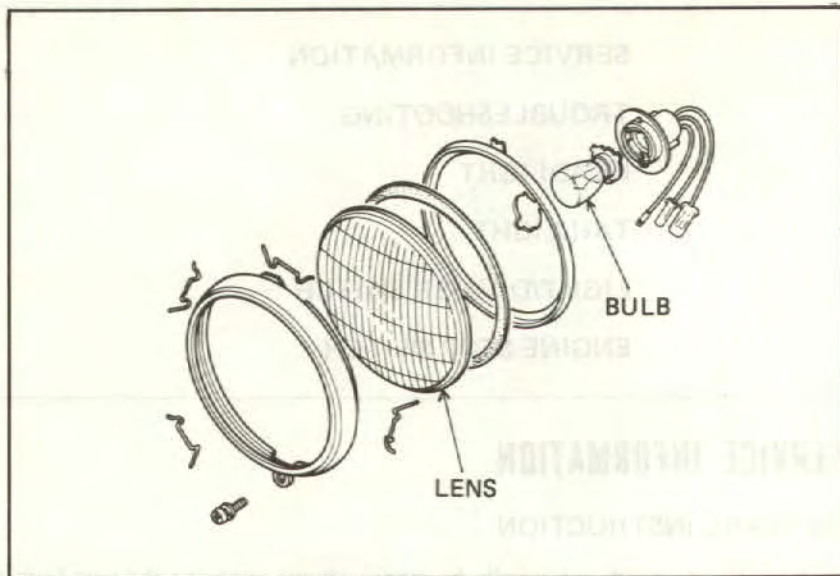

## TAILLIGHT

### TAILLIGHT DISASSEMBLY

Pull up the carrier box lid.  
Remove the bolt and taillight with the bracket.

Remove the lens screws.  
Remove the bulb.

### TAILLIGHT ASSEMBLY

Assemble the taillight in the reverse order of disassembly.

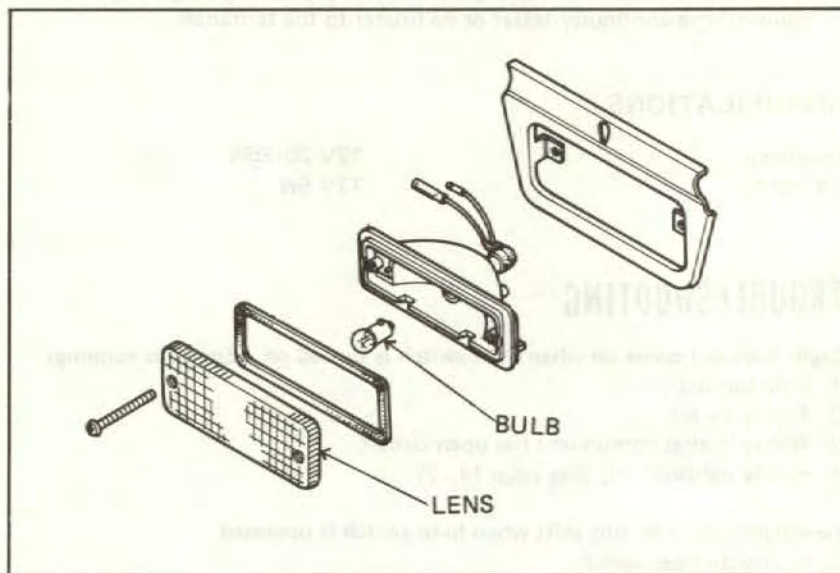





### LIGHT / DIMMER SWITCH

Remove the headlight (Page 15-2).  
Check the switch for continuity between the terminals shown in the table for each switch position.

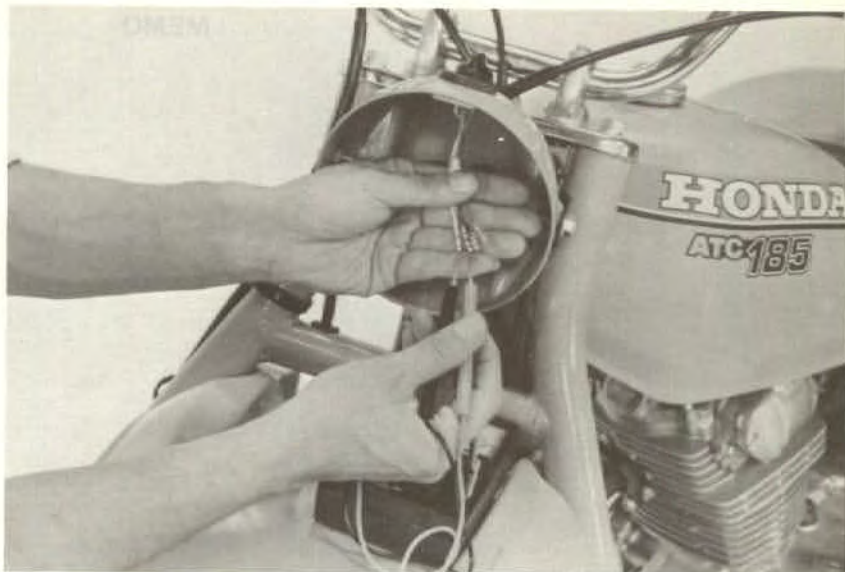

LIGHT SWITCH	WHITE	YELLOW	BROWN	BLUE
OFF				
LOW	○—○	○—○	○—○	
(N)	○—○	○—○	○—○	○—○
HIGH	○—○	○—○		○—○

The switch is normal if there is continuity between the circuit marked "O—O".

### ENGINE STOP SWITCH

Remove the headlight (Page 15-2).  
Check the switch for continuity between the Black and Green terminals with the switch "OFF".

The switch is normal if there is continuity between the terminals.

	BLACK	GREEN
OFF	○—○	
ON		

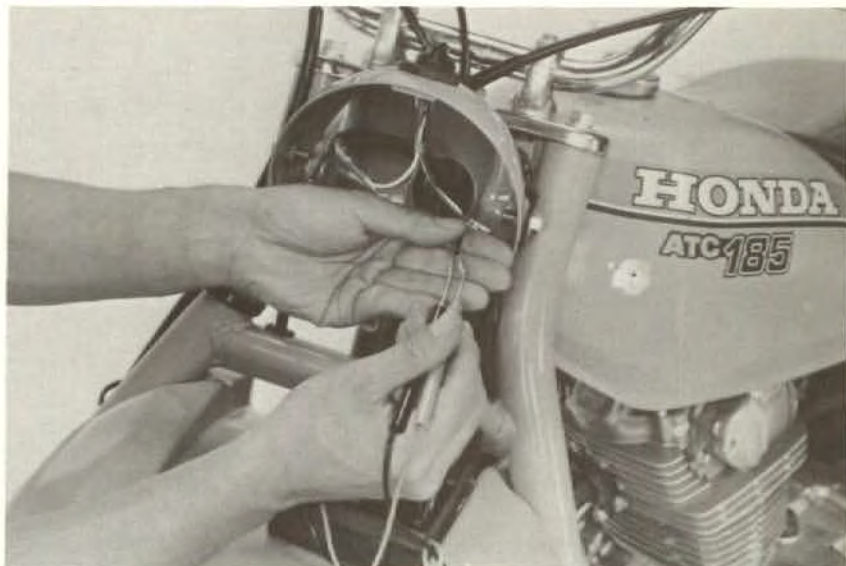



LIGHT SWITCH

**MEMO**

LIGHT SWITCH

Light switch (Part No. 18-21)  
The switch is controlled by the  
light switch on the left handle  
of the engine.



WHITE	YELLOW	GREEN

The switch is controlled by the  
light switch on the left handle  
of the engine.

ENGINE STOP SWITCH

Engine stop switch (Part No. 18-31)  
The switch is controlled by the  
engine stop switch on the left  
handle of the engine.



BLACK	GREEN





# 16. WIRING DIAGRAM

## WIRING DIAGRAM

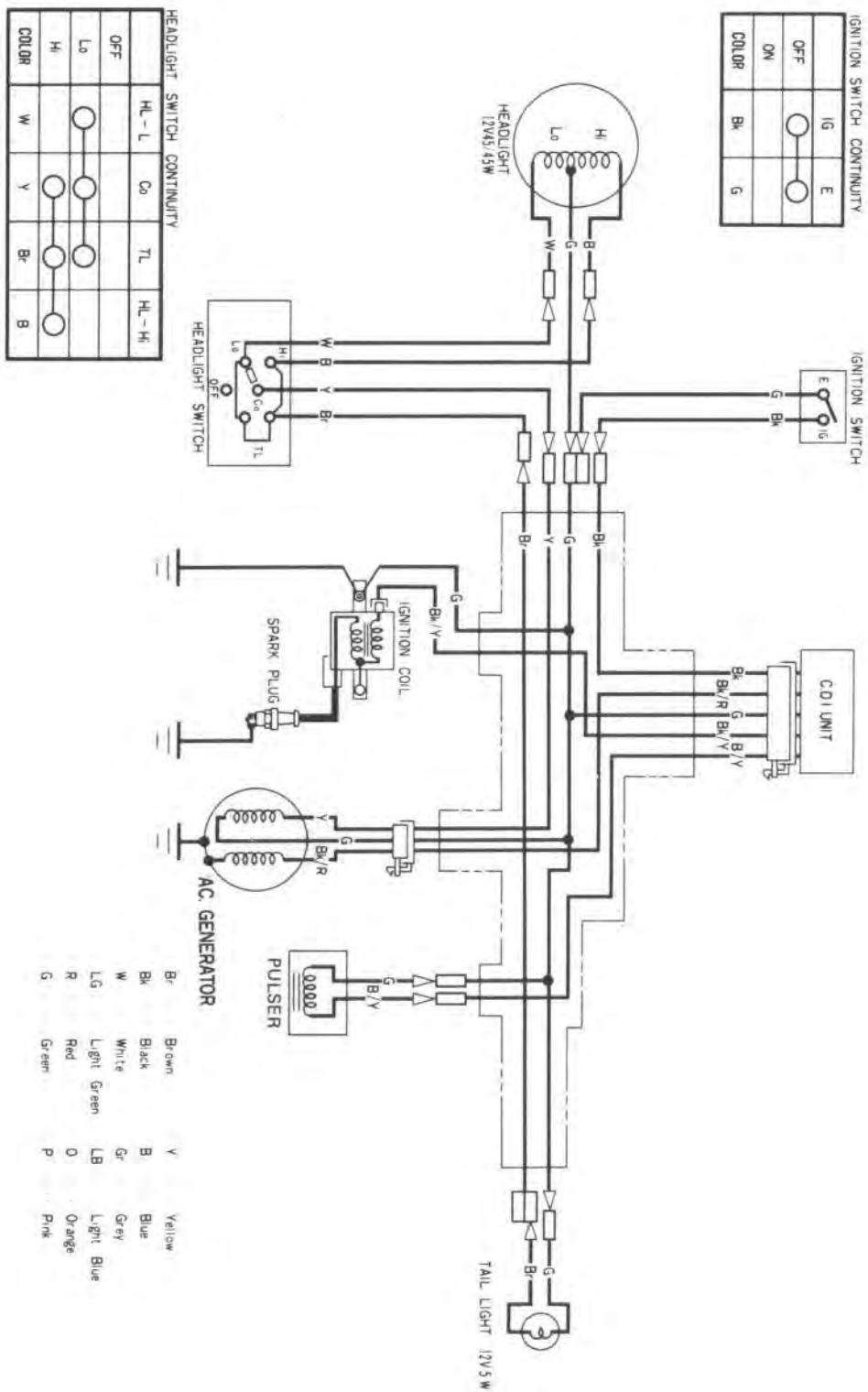



MEMO

WIRING DIAGRAM

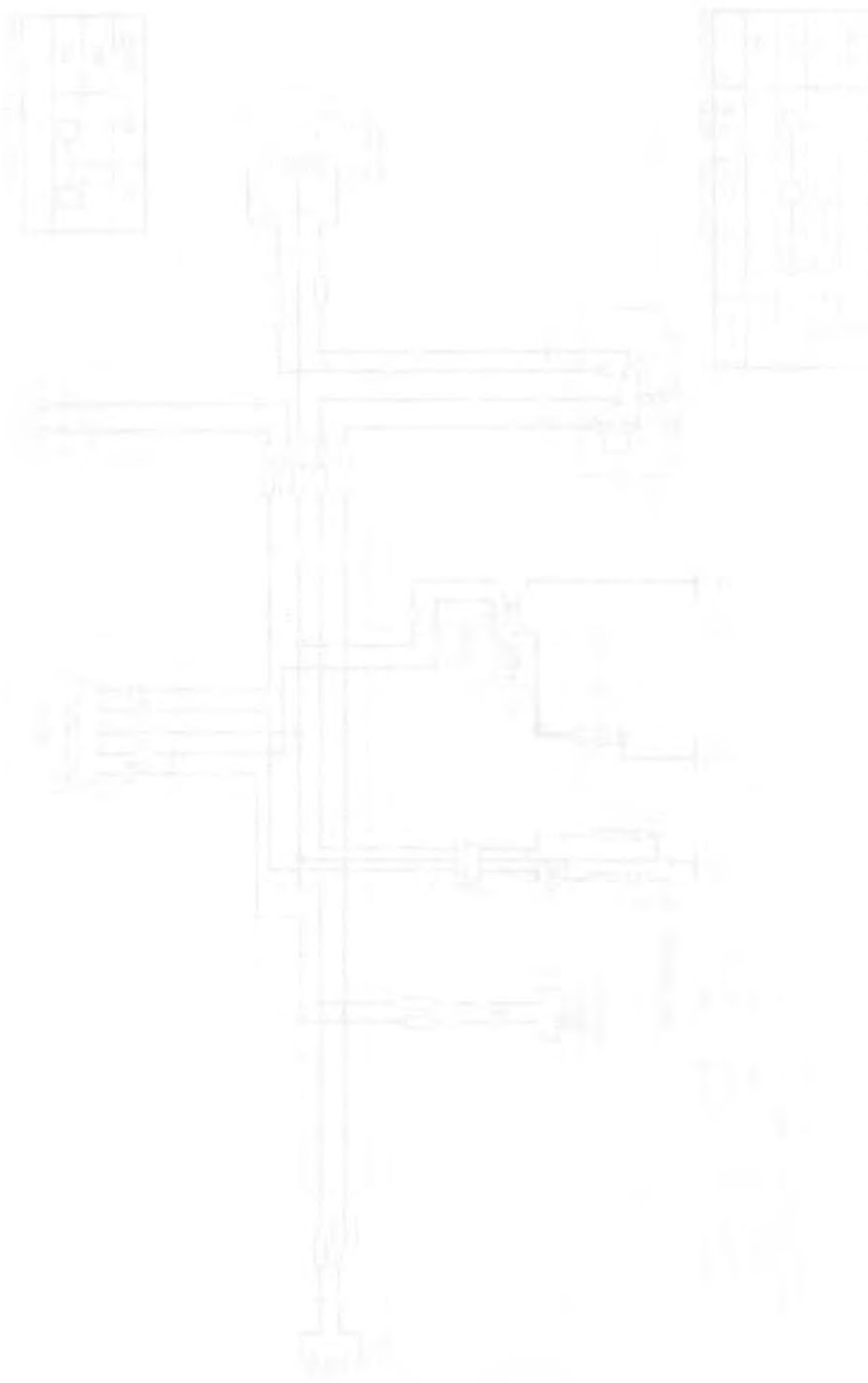



## TECHNICAL FEATURES

### CLUTCH

The ATC has two clutches; a centrifugal and a manual.

#### Centrifugal Clutch

The centrifugal clutch is mounted on the right crankshaft. Its major components are: An outer drum, clutch weights and a one-way sprag.

**Outer drum** — Has the primary drive gear. It drives the manual clutch when the clutch shoes engage it. The outer drum is not driven directly by the crankshaft.

**Clutch weights (3)** — Connected to a crankshaft mounted splined hub, the weights drive the outer drum at speeds above 2,100 rpm.

**One-way sprag** — Allows engine compression to be used for braking when the ATC is coasting and the clutch weights are disengaged.

Centrifugal force overcomes clutch weight spring pressure at 2,100–2,500 rpm pressing the weights against the outer drum. Complete shoe engagement occurs at 2,800–3,000 rpm. The outer drum is then able to drive the transmission mainshaft, and manual clutch. The springs begin disengaging the weights from the outer drum below 3,000 rpm.

The one-way sprag engages the outer drum with the crankshaft when the ATC is coasting in gear and the centrifugal clutch weights are disengaged. This allows engine compression braking. If the one-way sprag were not used the ATC would "free-wheel" under the same conditions, as if in neutral, and braking would not be aided by engine compression.

#### Manual Clutch

Mounted on the mainshaft, the manual clutch is a multi-plate wet type. It is driven by the outer drum's primary drive gear, as explained above.

The manual clutch is engaged and disengaged with the gearshift linkage.

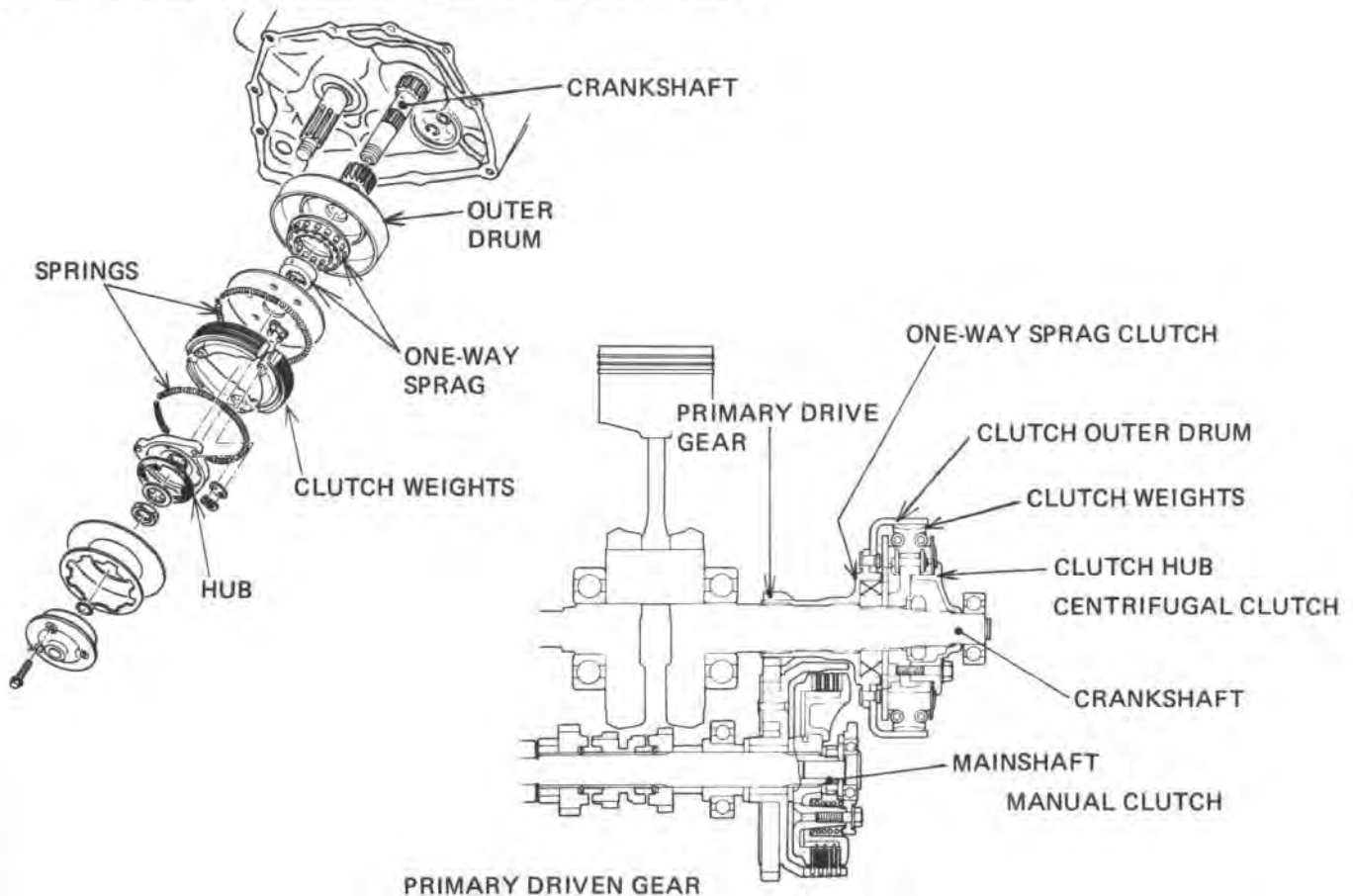





# 18. TROUBLESHOOTING

ENGINE DOES NOT START OR IS HARD TO START	18-1
ENGINE LACKS POWER	18-2
POOR PERFORMANCE AT LOW AND IDLE SPEEDS	18-3
POOR PERFORMANCE AT HIGH SPEEDS	18-4
POOR HANDLING	18-4

## ENGINE DOES NOT START OR IS HARD TO START





**ENGINE LACKS POWER**

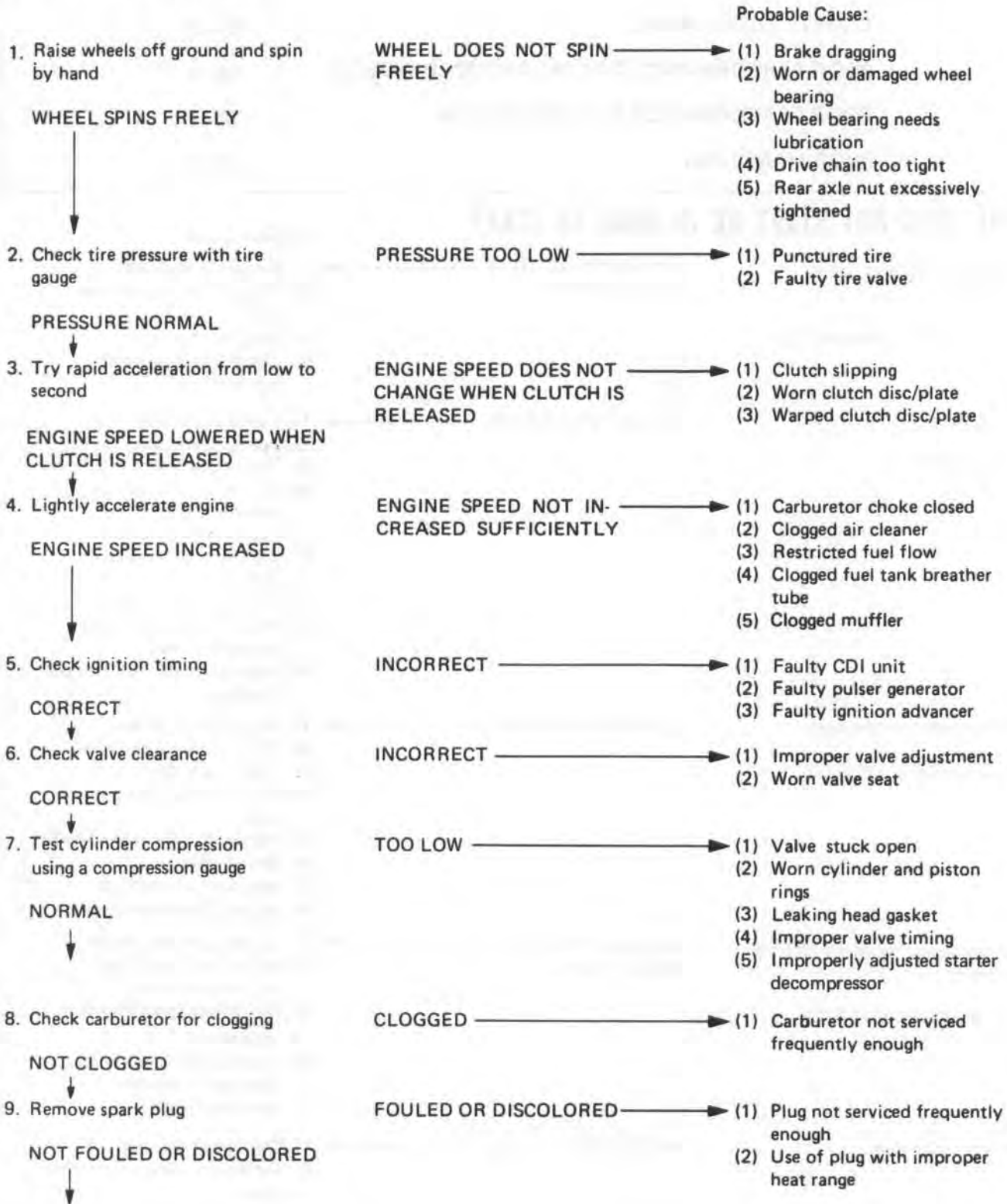





10. Remove oil level gauge and check oil level

CORRECT



11. Remove cylinder head cover and inspect lubrication

VALVE TRAIN LUBRICATED PROPERLY



12. Check if engine overheats

NOT OVERHEATED



13. Accelerate or run at high speed

ENGINE DOES NOT KNOCK

OIL LEVEL INCORRECT



- (1) Oil level too high
- (2) Oil level too low
- (3) Contaminated oil

VALVE TRAIN NOT LUBRICATED PROPERLY



- (1) Clogged oil passage
- (2) Clogged oil control orifice

OVERHEATED



- (1) Excessive carbon build-up in combustion chamber
- (2) Use of improper quality of fuel
- (3) Clutch slipping
- (4) Fuel-air mixture too lean

ENGINE KNOCKS



- (1) Worn piston and cylinder
- (2) Fuel-air mixture too lean
- (3) Use of improper grade of fuel
- (4) Excessive carbon build-up in combustion chamber
- (5) Ignition timing too advanced (Faulty CDI unit or advancer)

## POOR PERFORMANCE AT LOW AND IDLE SPEEDS

Probable Cause:

1. Check ignition timing and valve clearance

CORRECT



2. Check carburetor pilot screw adjustment

CORRECT



3. Check if air is leaking past carburetor insulator

NOT LEAKING



4. Try spark test

GOOD SPARK

INCORRECT



- (1) Improper valve clearance
- (2) Improper ignition timing (Faulty CDI unit or spark advancer)

INCORRECT



- (1) Fuel-air mixture too lean
- (2) Fuel-air mixture too rich

LEAKING



- (1) Deteriorated insulator O-ring
- (2) Loose carburetor

WEAK OR INTERMITTENT SPARK



- (1) Faulty, carbon or wet fouled spark plug
- (2) Faulty CDI unit
- (3) A.C. generator faulty
- (4) Faulty ignition coil
- (5) Faulty pulser advancer



**TROUBLESHOOTING**

**POOR PERFORMANCE AT HIGH SPEEDS**

		Probable Cause
1. Check ignition timing and valve clearance	INCORRECT	(1) Improper valve clearance (2) Faulty CDI unit (3) Faulty pulser generator (4) Faulty advancer
CORRECT		
2. Disconnect fuel tube at carburetor	FUEL FLOW RESTRICTED	(1) Lack of fuel in tank (2) Clogged fuel line (3) Clogged fuel tank breather tube (4) Clogged fuel valve
FUEL FLOWS FREELY		
3. Remove carburetor and check for clogged jet	CLOGGED	(1) Clean
NOT CLOGGED		
4. Check valve timing	INCORRECT	(1) Cam sprocket not installed properly
CORRECT		
5. Check valve spring tension	WEAK	(1) Faulty spring
NOT WEAKENED		

**POOR HANDLING**

Check tire pressure

	Probable Cause
1. If steering is heavy	(1) Steering head adjuster too tight (2) Damaged steering cones or steel balls
2. If either wheel is wobbling	(1) Excessive wheel bearing play (2) Distorted rim (3) Improperly installed wheel hub (4) Swing arm pivot bushing excessively worn (5) Distorted frame (6) Improper drive chain tension or adjustment
3. If the motorcycle pulls to one side	(1) Misaligned shock absorber (2) Front and rear wheels not aligned (3) Bent front fork (4) Bent swing arm



# 19. ADDENDUM

## INTRODUCTION

This '81 addendum contains service information for the ATC185S • 200.

Refer to the base Shop Manual for service items not described in this addendum.

## CONTENTS

1. GENERAL INFORMATION.....	19-2
–Specifications.....	19-2
–Torque Values.....	19-5
–Cable and Harness Routing.....	19-6
–Maintenance Schedule.....	19-7
2. INSPECTION/ADJUSTMENT.....	19-8
–Air Cleaner and Case.....	19-8
–Clutch.....	19-9
–Crankcase Breather.....	19-9
3. FRONT WHEEL/BRAKE/STEERING..	19-10
–Front Wheel.....	19-11
–Fork Bridge Installation.....	19-11
4. REAR WHEEL/BRAKE/DRIVE.....	19-12
–Rear Axle/Final Driven Sprocket.....	19-13
5. LIGHTS/SWITCHES.....	19-13
–Headlight.....	19-13
–Lighting Switch.....	19-14
6. WIRING DIAGRAM.....	19-15



**1. GENERAL INFORMATION**  
**SPECIFICATIONS**

• ATC185S

DIMENSIONS	Overall length Overall width Overall height Wheel base Rear tread Seat height Foot peg height Ground clearance Dry weight	1,720 mm (67.7 in) 1,000 mm (39.4 in) 965 mm (38.0 in) 1,118 mm (44.0 in) 745 mm (29.3 in) 667 mm (26.3 in) 250 mm ( 9.8 in) 110 mm ( 4.3 in) 127 kg (280 lb)
FRAME	Type Rim size                      Front Rear  Tire    Front size, pressure Rear size, pressure Standard circumference  Front brake Rear brake Fuel capacity Fuel reserve capacity Caster Trail	Semi-double cradle 8.27 x 8.0 8.27 x 8.0 22 x 11.0-8, 0.15 kg/cm <sup>2</sup> (2.2 psi) 22 x 11.0-8, 0.15 kg/cm <sup>2</sup> (2.2 psi) 1743 mm (68.6 in) Cable operated leading shoe Cable operated leading shoe 8.8 liters (2.3 US gal, 1.9 Imp gal) 1.6 liters (0.42 US gal, 0.35 Imp gal) 70° 20' 20 mm (0.79 in)
ENGINE	Type Cylinder arrangement Bore x stroke Displacement Compression ratio Valve train Maximum horsepower Maximum torque  Oil capacity  Lubrication system Cylinder compression Intake valve                      OPENS CLOSES  Exhaust valve                    OPENS CLOSES  Valve clearance                Intake (Cold)                                  Exhaust	Gasoline, air cooled 4-stroke Single cylinder inclined 15° 63.0 x 57.8 mm (2.48 x 2.28 in) 180.2 cc (11.01 cu in) 8.0:1 Overhead camshaft chain driven 13 BHP/7,000 rpm 1.38 kg-m/5,500 rpm (9.26 ft-lb/5,500 rpm) 1.35 lit (1.43 US qt, 1.19 Imp qt) 1.3 lit (1.37 US qt, 1.14 Imp qt) after draining Forced pressure and wet sump 11 ± 1.0 kg/cm <sup>2</sup> (156 ± 14 psi) 5° BTDC                              } 35° ABDC                            } at 1 mm lift 35° BBDC                            } 5° ATDC                                }
CARBURETOR	Type Main jet Pilot screw opening Float level Idle speed Venturi dia.	Piston valve # 95 2 turns out 12.5 mm (0.49 in) 1,400 ± 100 rpm 22 mm (0.9 in)



DRIVE TRAIN	Clutch		Wet multi-plate, semi-automatic
	Transmission		5-speed constant mesh
	Primary reduction		3.333:1
	Gear ratio	I	2.769:1
		II	1.722:1
		III	1.273:1
		IV	1.000:1
		V	0.815:1
	Final reduction		3.727:1
	Gearshift pattern		Left foot operated return system N-1-2-3-4-5
	Drive chain		520, 82L
ELECTRICAL	Ignition		CDI
	Ignition timing	Initial	10° ± 2° BTDC at idle
		Full advance	30° ± 2° BTDC at 3,350
	Alternator	Capacity	12V 50W/5,000 rpm
	Spark plug	USA model	X24ES-U (ND)
			D8EA (NGK)
		Canada model	X24ESR-U (ND)
			DR8ES-L (NGK)
	Spark plug gap		0.6-0.7 mm (0.024-0.028 in)
	Headlight		12V 45W/45W
	Taillight		12V (5W)

• ATC200

DIMENSIONS	Overall length		1,810 mm (71.3 in)
	Overall width		1,100 mm (43.3 in)
	Overall height		995 mm (39.2 in)
	Wheel base		1,160 mm (45.7 in)
	Rear tread		800 mm (31.5 in)
	Seat height		680 mm (26.8 in)
	Foot peg height		275 mm (10.8 in)
	Ground clearance		130 mm (5.1 in)
	Dry weight		144 kg (317 lb)
	FRAME	Type	
Rim size		Front	10.0 x 9.0
		Rear	10.0 x 9.0
Front tire size, pressure			25 x 12-9, 0.15 kg/cm <sup>2</sup> (2.2 psi)
Rear tire size, pressure			25 x 12-9, 0.15 kg/cm <sup>2</sup> (2.2 psi)
Front brake			Cable operated leading shoe
Rear brake			Cable operated leading shoe
Fuel capacity			8.8 liters (2.3 US gal, 1.9 Imp gal)
Fuel reserve capacity			1.6 liters (0.42 US gal, 0.35 Imp gal)
Caster		70° 30'	
Trail		30 mm (1.2 in)	



'81 ADDENDUM

ENGINE	Type Cylinder arrangement Bore x stroke Displacement Compression ratio Valve train Maximum horsepower Maximum torque  Oil capacity  Lubrication system Cylinder compression Intake valve  Exhaust valve  Valve clearance (Cold)	Gasoline, air-cooled 4-stroke Single cylinder inclined 15° 65.0 x 57.8 mm (2.56 x 2.28 in) 192 cc (11.7 cu in) 7.8:1 Overhead camshaft chain driven 12.9 BHP/7,000 rpm 1.46 kg-m/5,500 rpm (10.6 ft-lb/5,500 rpm) 1.35 lit (1.43 US qt, 1.19 Imp qt) 0.95 lit (1.00 US qt, 0.84 Imp qt) after draining Forced pressure and wet sump 12 ± 0.5 kg/cm <sup>2</sup> (170 ± 7 psi) 5° BTDC 35° ABDC 35° BBDC 5° ATDC } at 1 mm lift Intake Exhaust 0.05 mm (0.002 in) 0.05 mm (0.002 in)
CARBURETOR	Type Main jet Pilot screw opening Float level Idle speed Venturi dia.	Piston valve # 105 2 turns out 12.5 mm (0.49 in) 1,400 ± 100 rpm 22 mm (0.9 in)
DRIVE TRAIN	Clutch Transmission Primary reduction Gear ratio  I II III IV V  Final reduction Gearshift pattern Drive chain	Wet multi-plate, semi-automatic 5-speed constant mesh 3.333:1 2.769:1 1.722:1 1.273:1 1.000:1 0.815:1 4.273:1 Left foot operated return system, N-1-2-3-4-5 520, 90 L
ELECTRICAL	Ignition Ignition timing  Alternator Spark plug    Spark plug gap Headlight Tail/stoptlight	CDI 10° ± 2° BTDC at idle 30° ± 2° BTDC at 3,350 rpm 12V 50W/5,000 rpm X24ES-U (ND) D8EA (NGK) X24ESR-U (ND) DR8ES-L (NGK) 0.6-0.7 mm (0.024-0.028 in) 12V 45W/45W 12V (5W)



**ATC200: STANDARDS AND SERVICE LIMITS**

Item		Standard	Service Limit
Centrifugal clutch	Spring free length	266.5 mm-268.5 mm (10.492-10.571 in)	282 mm (11.0 in)
Cylinder	I.D.	65.000-65.010 mm (2.5591-2.5594 in)	65.10 mm (2.563 in)
Piston	Piston O.D.	64.995-64.985 mm (2.5573-2.5585 in)	64.90 mm (2.555 in)

NOTE: Refer to the base shop manual for all other standards and service limits.

**TORQUE VALUES**

**ENGINE**

Item	Q'ty	Thread Size (mm)	Torque	
			kg-m	ft-lb
ATC200: Cylinder head bolt	4	8 x 1.25	2.0-2.2	14-16
Clutch lock nut	1	16 x 1.0	5.0-6.0	36-43
A.C. generator rotor nut	1	12 x 1.25	6.5-7.5	47-54
Valve adjuster cover	2	36 x 1.5	1.0-1.4	7-10
Oil filler cap	1	36 x 1.5	0.9-1.5	7-11

**FRAME**

Item	Q'ty	Thread Size (mm)	Torque	
			kg-m	ft-lb
Fork bridge bolt	2	12 x 1.25	5.0-7.0	36-51
ATC185S: Front hub nut	3	8 x 1.25	1.9-2.5	14-18
ATC185S: Front/rear rim nut	9	8 x 1.25	1.9-2.5	14-18
ATC185S: Damper holder nut	4	10 x 1.25	4.4-5.2	32-38
Rear brake drum nut Inner	1	32 x 1.0	3.5-4.5	25-33
Outer	1	32 x 1.0	8.0-12.0	58-87
ATC185S: Front mudguard bolt	3	5 x 0.8	0.4-0.8	2.9-5.8
ATC185S: Rear hub nut	6	8 x 1.25	1.9-2.5	14-18
ATC185S: Rear mudguard bolt	10	4 x 0.7	0.5-0.7	3.6-5.1
ATC185S: Rear fender nut	8	6 x 1.0	0.6-0.9	4.3-6.5
ATC185S: Seat lock lever pivot bolt	1	6 x 1.0	0.7-1.2	5.1-8.7
ATC185S: Shield flange nut	4	6 x 1.0	0.7-1.2	5.1-8.7

Torque specifications listed above are for the most important tightening points. If a torque specification is not listed, follow the standards given below.

**STANDARD TORQUE VALUES**

Item	Torque kg-m (ft-lb)	Item	Torque kg-m (ft-lb)
5 mm bolt, nut	0.45-0.6 (3.3-4.3)	5 mm screw	0.35-0.5 (2.5-3.6)
6 mm bolt, nut	0.8-1.2 (5.8-8.7)	6 mm screw	0.7-1.1 ( 5-8 )
8 mm bolt, nut	1.8-2.5 ( 13-18 )	6 mm flange bolt, nut	1.0-1.4 (7.2-10)
10 mm bolt, nut	3.0-4.0 ( 22-29 )	8 mm flange bolt, nut	2.4-3.0 ( 17-22 )
12 mm bolt, nut	5.0-6.0 ( 36-43 )	10 mm flange bolt, nut	3.0-4.0 ( 22-29 )



**CABLE AND HARNESS ROUTING**

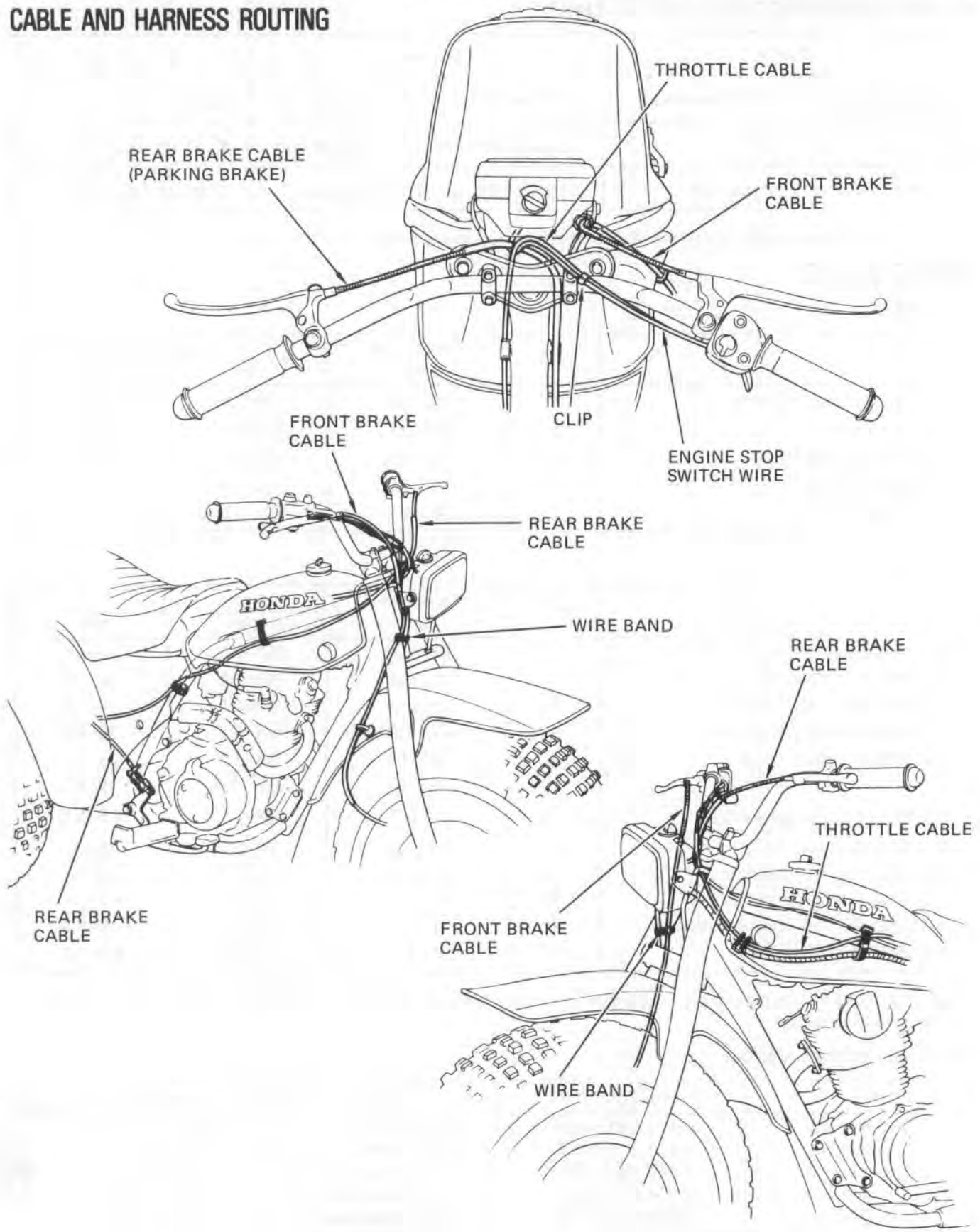





## MAINTENANCE SCHEDULE

Perform the PRE-RIDE INSPECTION in the Owner's Manual at every maintenance period.

### REGULAR MAINTENANCE SCHEDULE

I : Inspect, Clean, Adjust, Lubricate or Replace if Necessary.

C: Clean

R: Replace

A: Adjust

	ITEM	INITIAL SERVICE PERIOD (First week of operation)	REGULAR SERVICE PERIOD (Every 30 operating days)	Ref. Page
	ENGINE OIL (NOTE 1, 2)	R	R	2-2
*	ENGINE OIL FILTER SCREEN	C	C	2-2
	AIR CLEANER ELEMENT (NOTE 2)		C	3-3
	SPARK PLUG		I	3-4
*	VALVE CLEARANCE	I	I	3-5
*	CAM CHAIN TENSIONER	A	A	3-6
*	CARBURETOR	I	I	3-6
	FUEL LINE	I: (EVERY YEAR)		3-6
*	FUEL STRAINER	C: (EVERY YEAR)		3-7
	THROTTLE OPERATION	I	I	3-7
	DRIVE CHAIN	I	I	3-9
*	BRAKE SHOES	I: (EVERY YEAR)		3-11
	BRAKE CONTROL LINKAGE	I	I	3-11
*	CLUTCH	A	A	19-9
*	SPARK ARRESTER		C	3-13
	ALL NUTS, BOLTS, FASTENERS	I	I	3-14
	LIGHTING EQUIPMENT	I	I	3-14
	TIRES	I	I	3-14
*	STEERING HEAD BEARING	A: (EVERY YEAR)		3-15

NOTES: 1. Replace every 30 operating days or every 3 months, whichever comes first.

2. Service more frequently when riding in dusty area.



## 2. INSPECTION/ADJUSTMENT

### AIR CLEANER AND CASE

Remove the seat.

Remove the air cleaner case cover and seal.

Remove the 3 air cleaner case attaching bolts and loosen the air cleaner connecting tube band.

Remove the air cleaner case.

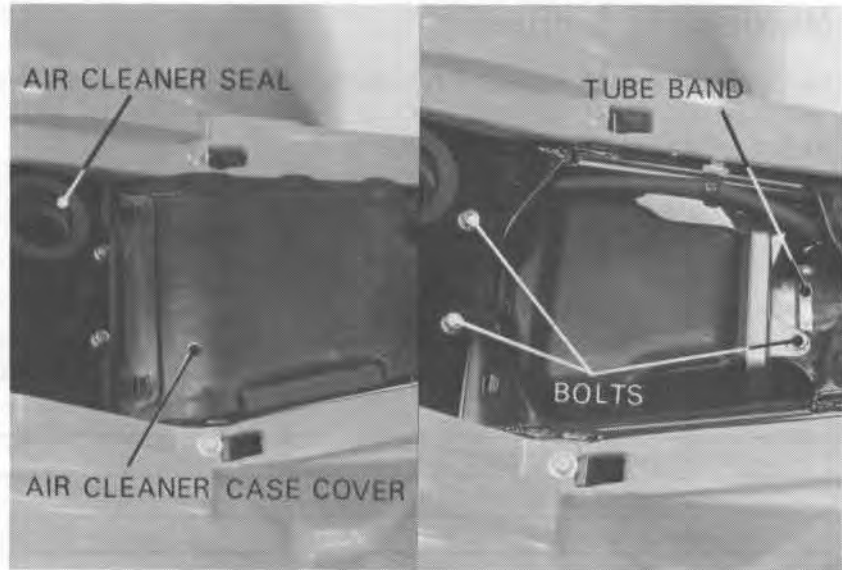

Remove the nut and air cleaner element from the air cleaner case.

For air cleaner element service, see page 3-3.

Install the air cleaner and case in the reverse order of removal.

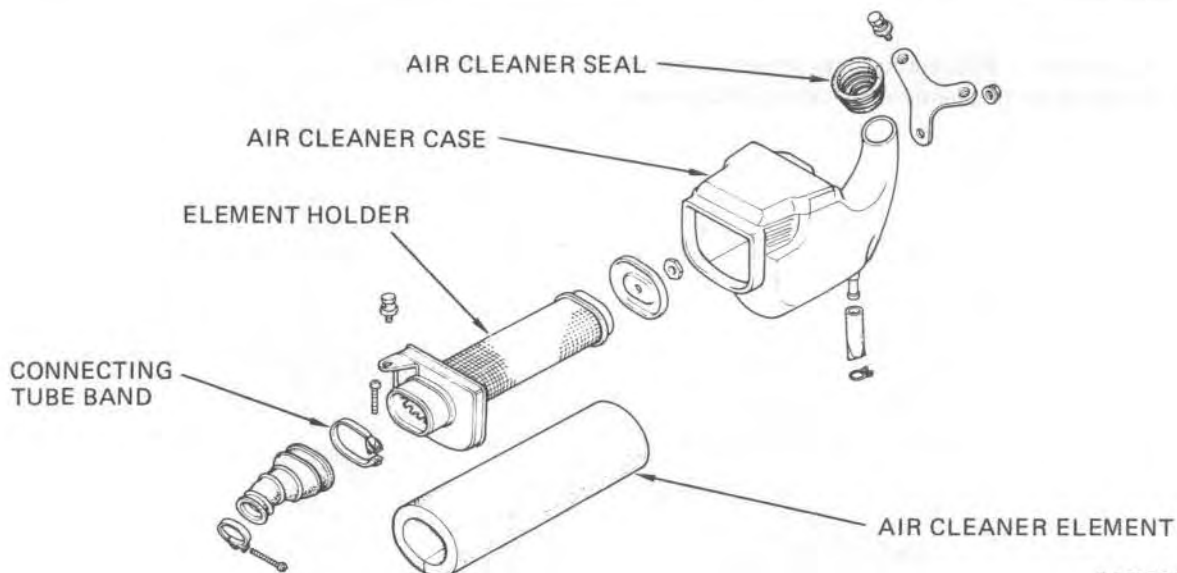

\*ATC200 SHOWN



## CLUTCH

Stop the engine.  
Loosen the clutch adjusting screw lock nut.

Slowly turn the adjusting screw counterclockwise until resistance is felt.

Then turn the adjusting screw clockwise 1/4 turn, and tighten the lock nut.

After adjustment, start the engine and check for proper clutch operation.

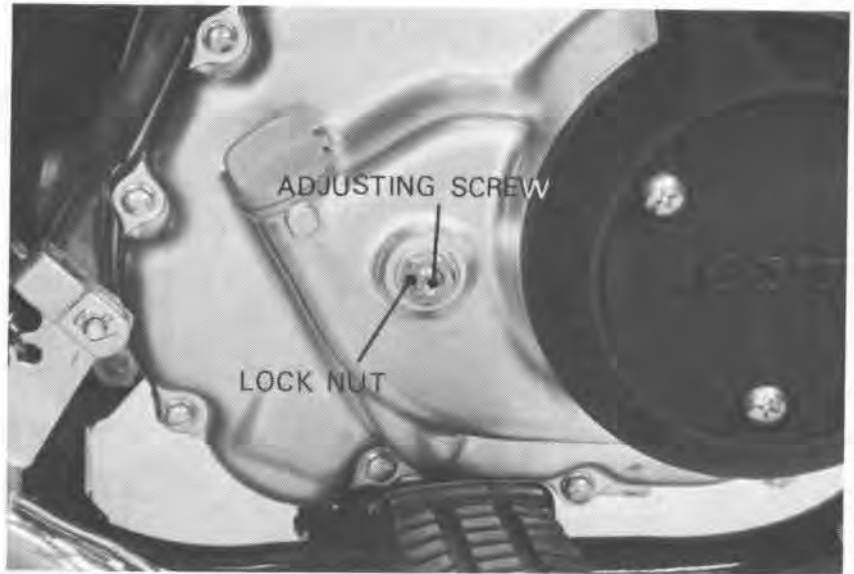

## CRANKCASE BREATHER

Route the crankcase breather tube as shown.

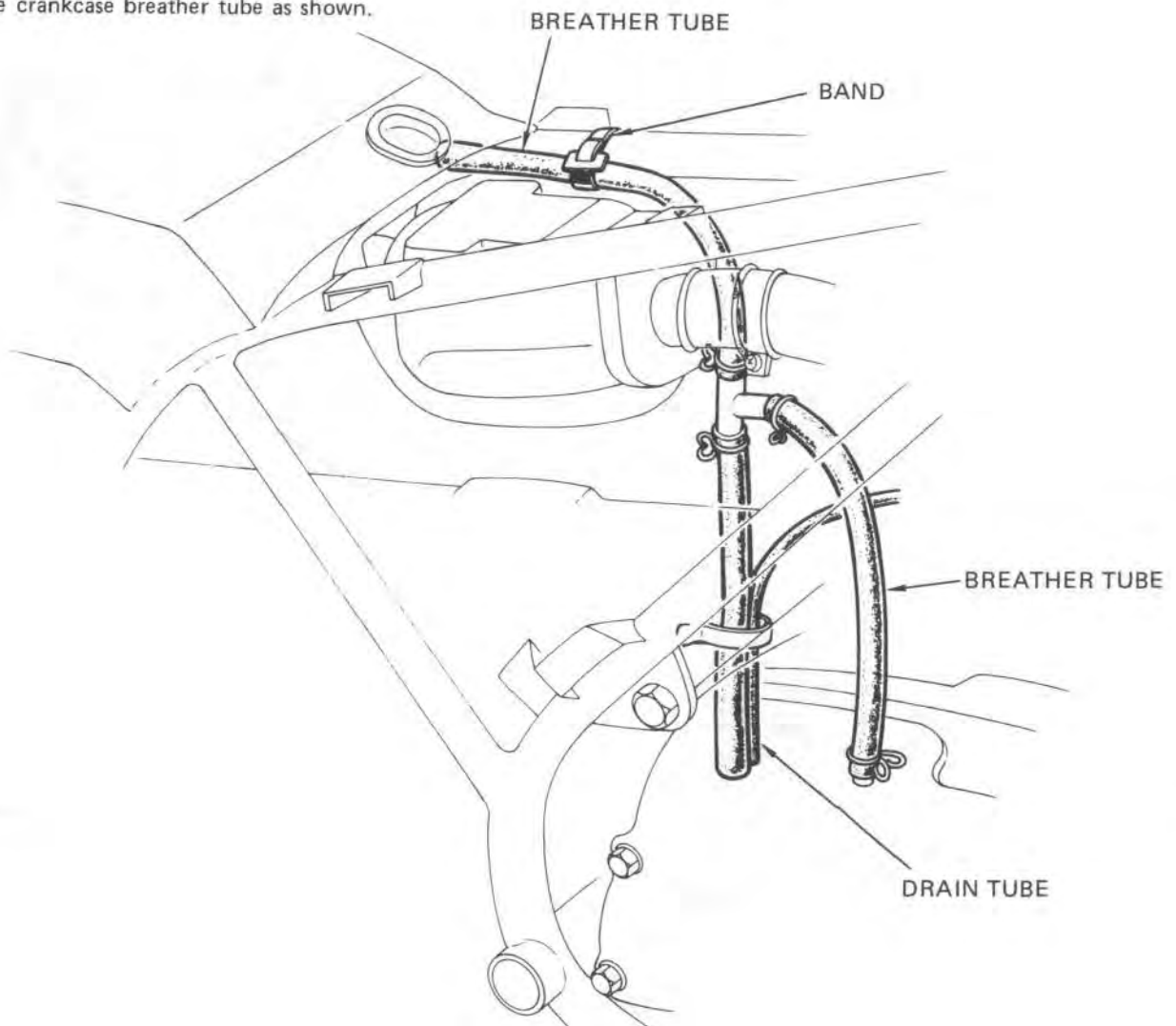



### 3. FRONT WHEEL/BRAKE/STEERING

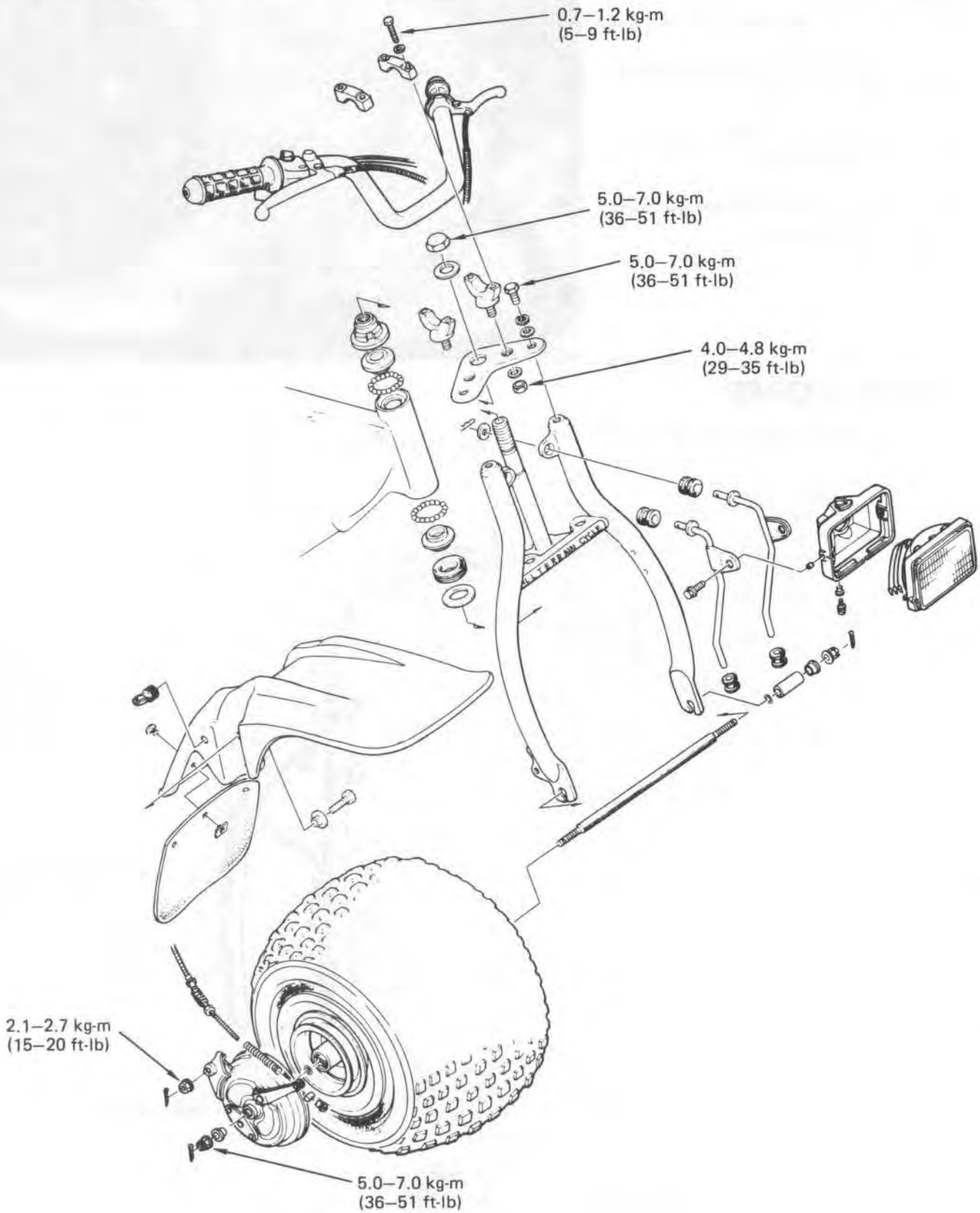



## FRONT WHEEL

### REMOVAL

Raise the front wheel off the ground by placing a block or safety stand under the engine.

Disconnect the front brake cable.

Remove the cotter pin, front brake panel nut, attaching bolt and collar.

Remove the cotter pins from both sides of the axle shaft.

Remove the axle nuts from both sides.

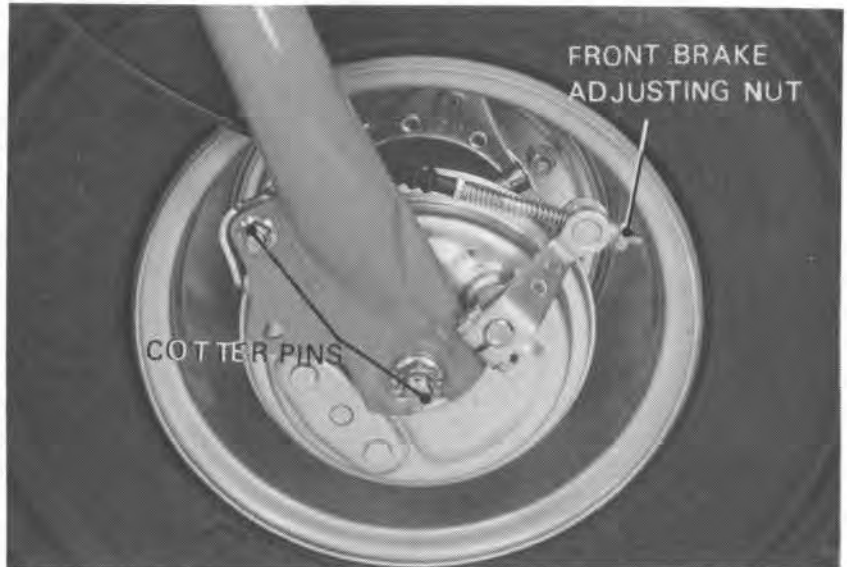

### INSTALLATION

Install the brake panel setting bolt, collar and nut.

Insert the cotter pin and spread the end.

**TORQUE: 2.1–2.7 kg-m (15–20 ft-lb)**

Tighten the two axle nuts.

**TORQUE: 5.0–7.0 kg-m (36–51 ft-lb)**

Install the new cotter pins and bend the ends securely as shown.

Connect the front brake cable and adjust the front brake lever free play (Page 3–11).

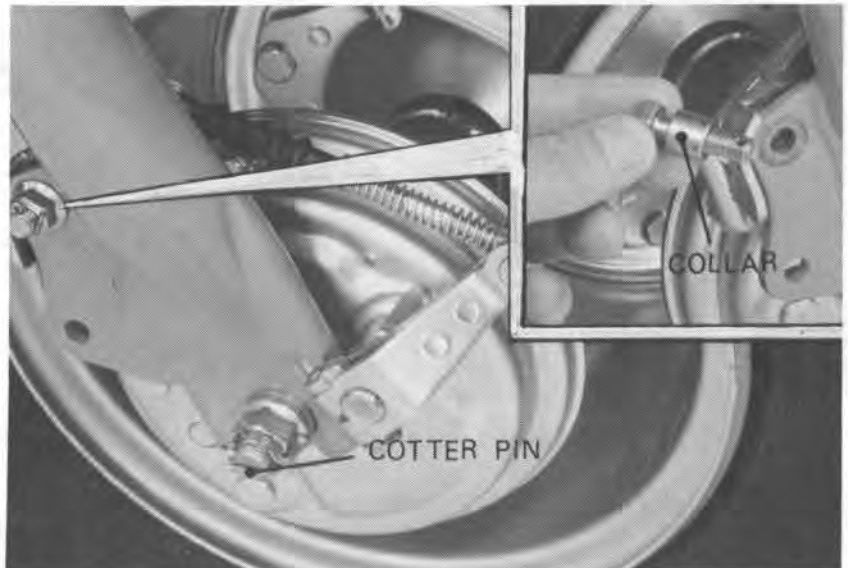

## FORK BRIDGE INSTALLATION

Install the fork bridge.

Tighten the steering stem nut.

**TORQUE: 5.0–7.0 kg-m (36–51 ft-lb)**

Tighten the fork bridge bolts.

**TORQUE: 5.0–7.0 kg-m (36–51 ft-lb)**





### 4. REAR WHEEL/BRAKE/DRIVE

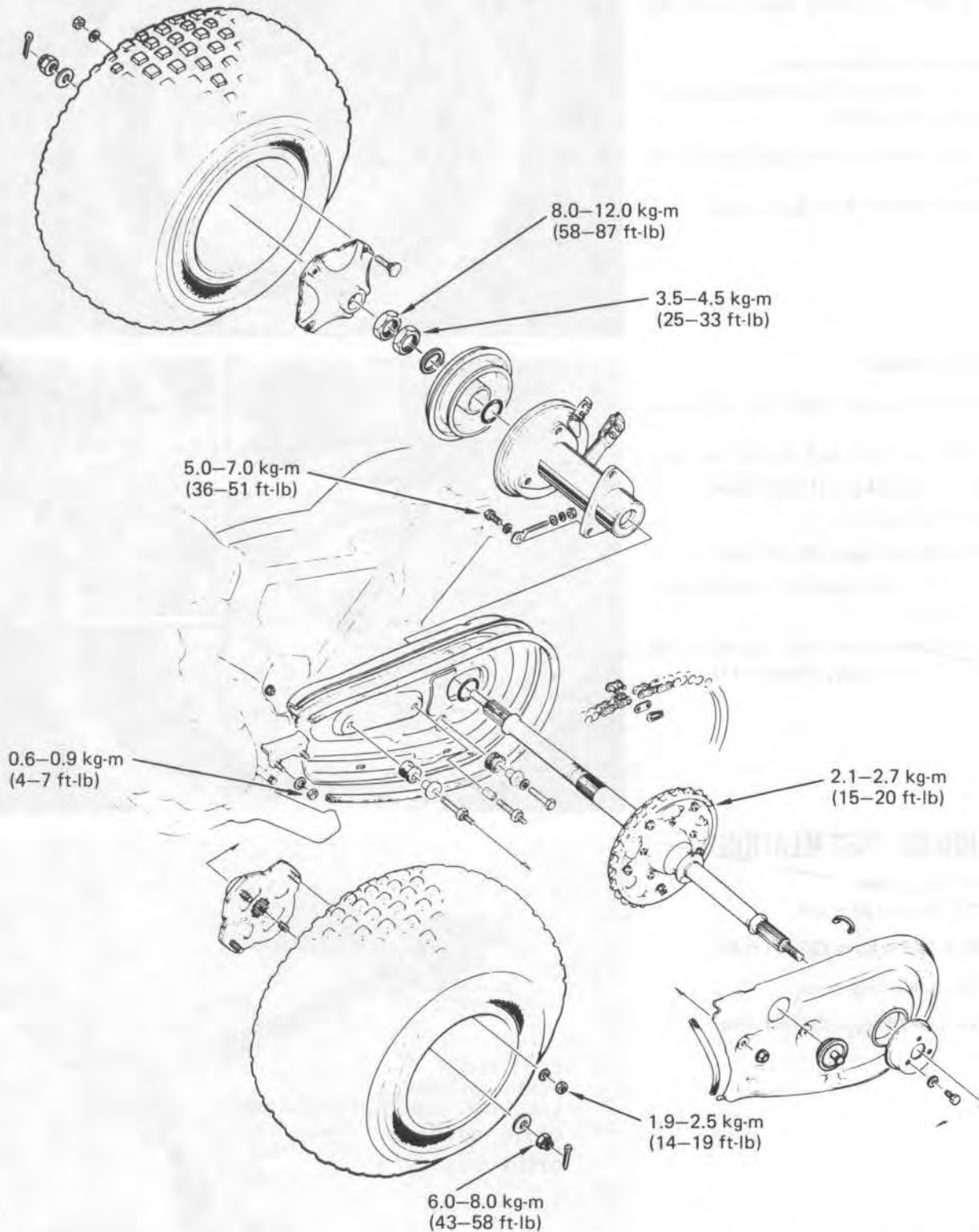

\*ATC200 SHOWN



## REAR AXLE/FINAL DRIVEN SPROCKET

### REAR AXLE REMOVAL

Apply the parking brake.  
Remove the brake drum nuts and washer.

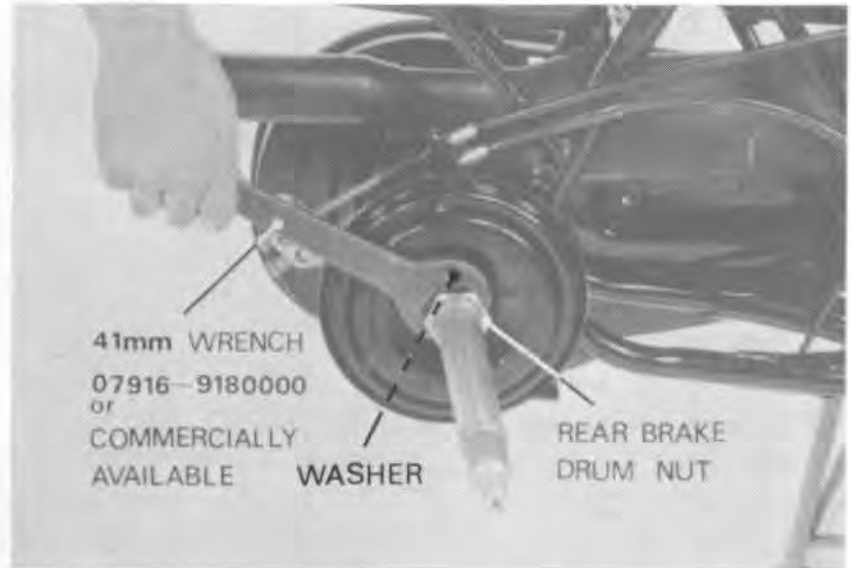

### REAR AXLE INSTALLATION

Install the tapered washer and brake drum nut.  
Tighten the brake drum nut.

**TORQUE: 3.5-4.5 kg-m (25-33 ft-lb)**

Apply LOCKTITE ® or equivalent to the shaft.

Tighten the brake drum outer nut while holding the inner nut with a wrench.

**TORQUE: 8.0-12.0 kg-m (58-87 ft-lb)**

#### NOTE

Wipe grease off the shaft before applying LOCKTITE ® or an equivalent.

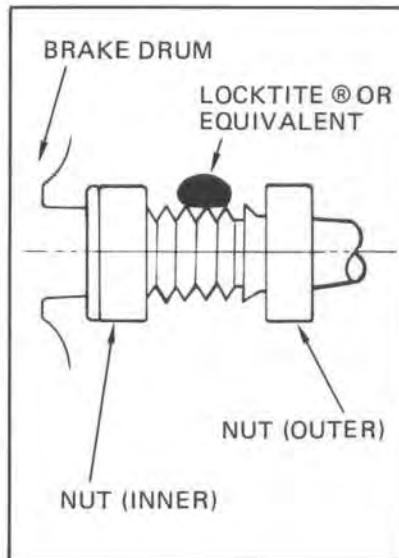

## 5. LIGHTS/SWITCHES

### HEADLIGHT

#### HEADLIGHT DISASSEMBLY

Remove the headlight mounting screw and disconnect the wires.

Remove and disassemble the headlight.

#### HEADLIGHT ASSEMBLY

Assemble the headlight in the reverse order of disassembly.

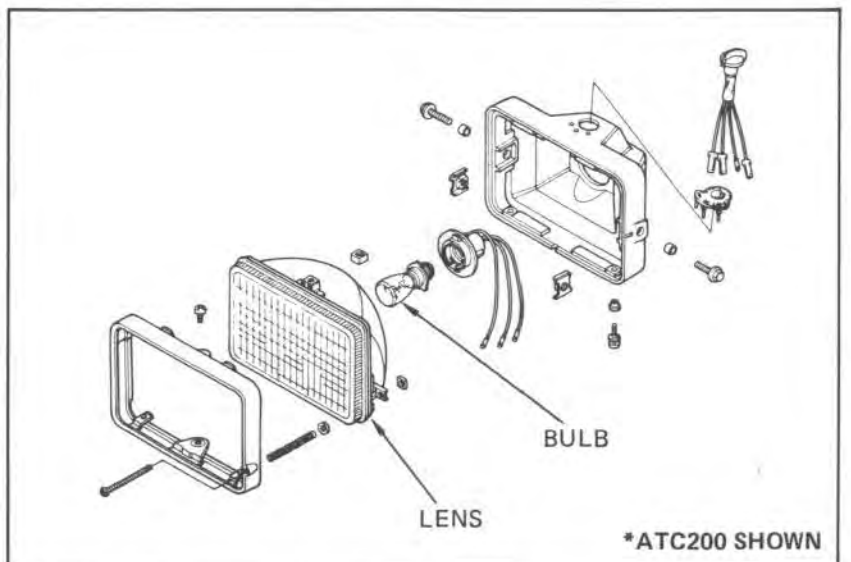





'81 ADDENDUM

**LIGHTING SWITCH**

Apply the parking brake lever.  
Start the engine.

Check the headlight and taillight by operating  
the switch on the headlight case.

Switch position	Function
OFF	: Lights are OFF
	: Headlight low beam and taillight are ON
	: Headlight high beam and taillight are ON

Replace the bulb or switch (page 15-3) if  
necessary.

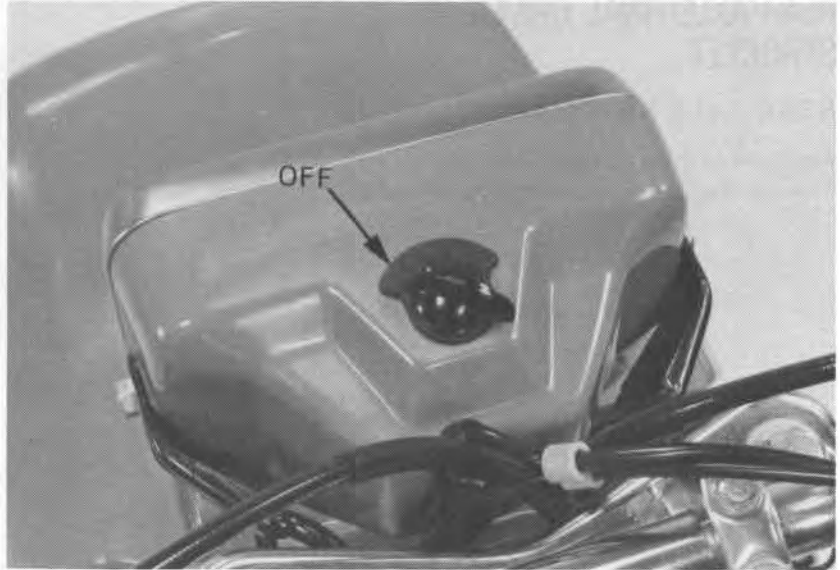





**HONDA**  
ATC185S-200

**6. WIRING DIAGRAM**

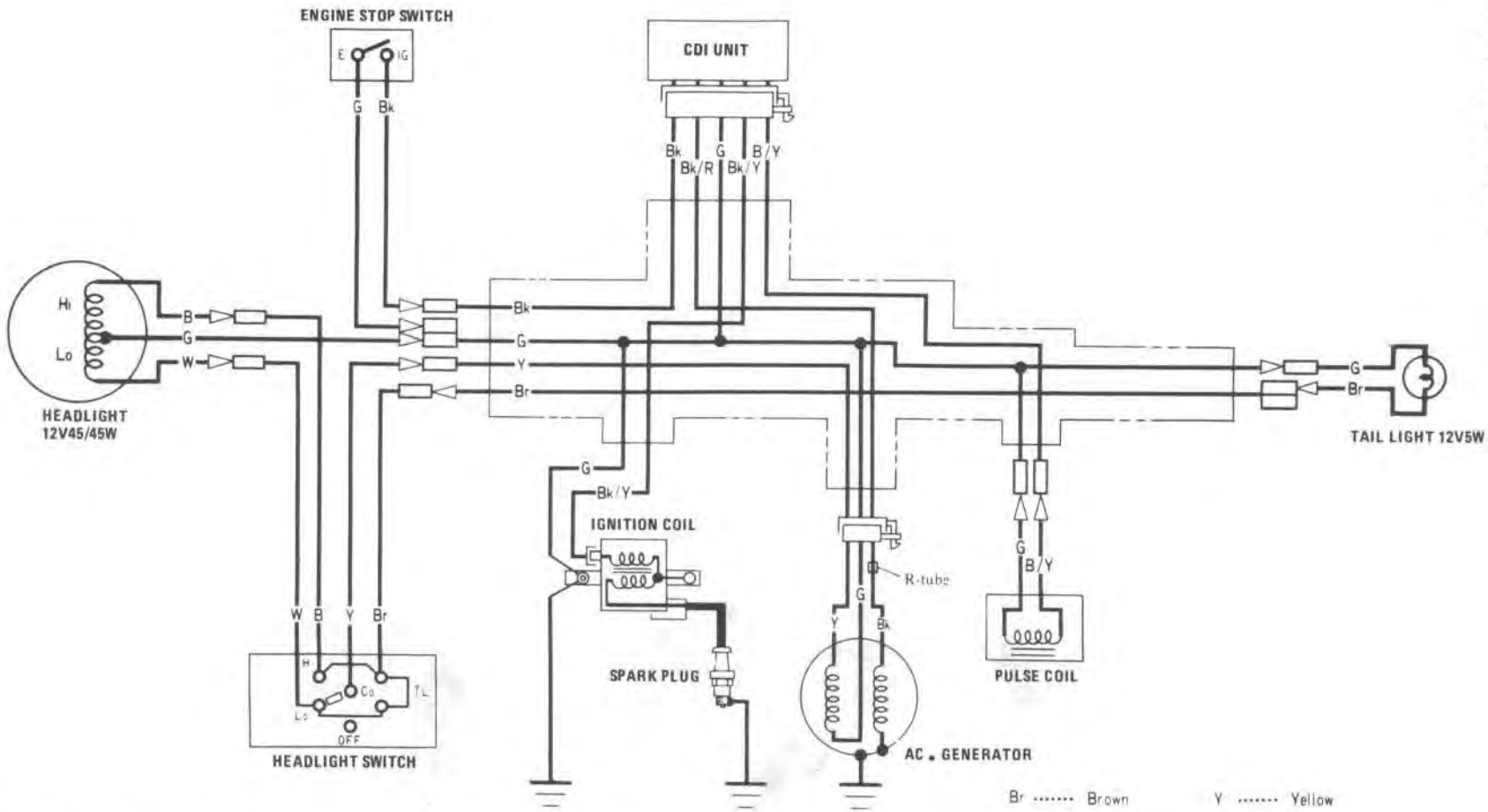

**HEADLIGHT SWITCH CONTINUITY**

	HL-L	Co	TL	HL-Hi
OFF				
Lo	○	○	○	
Hi		○	○	○
COLOR	W	Y	Br	B

**IGNITION SWITCH CONTINUITY**

	IG	E
OFF	○	○
ON		
COLOR	Bk	G

- Br ..... Brown
- Bk ..... Black
- W ..... White
- LG ..... Light Green
- R ..... Red
- G ..... Green
- Y ..... Yellow
- B ..... Blue
- Gr ..... Grey
- LB ..... Light Blue
- O ..... Orange
- P ..... Pink



MEMO

WIRING DIAGRAM

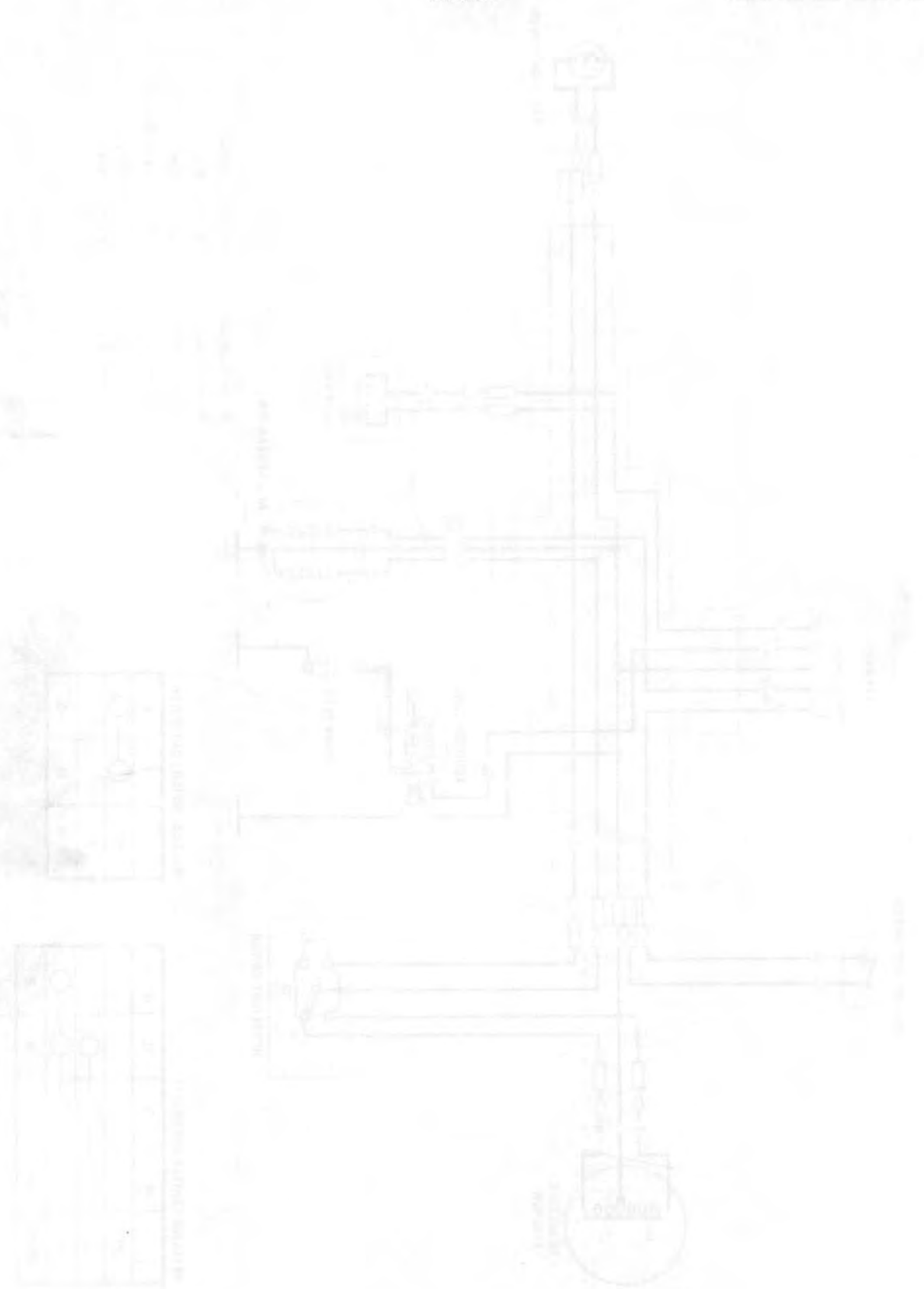



**INTRODUCTION**

This '82 addendum contains service information for the ATC185S•200.

Refer to the base Shop Manual and the previous addendum for service information not included in this addendum.

**CONTENTS**

1. GENERAL INFORMATION.....	20-2
– Specifications .....	20-2
– Maintenance Schedule.....	20-3
– Cable and Harness Routing .....	20-4
2. LUBRICATION .....	20-5
3. INSPECTION/ADJUSTMENT .....	20-5
– Air Cleaner and Case .....	20-5
– High Altitude Adjustment.....	20-7
4. FRONT WHEEL/BRAKE/STEERING . . .	20-8
5. REAR WHEEL/BRAKE/ DRIVE MECHANISM.....	20-10
6. WIRING DIAGRAM.....	20-14
7. RECOIL STARTER .....	20-15



## 1. GENERAL INFORMATION

These specifications and torque figures are the only changes from the 1981 information listed in section 19.

### SPECIFICATIONS

#### • ATC185S

DIMENSIONS	Dry weight	125.5 kg (276 lb)
CARBURETOR	Main jet	# 100
ELECTRICAL	Spark plug	X24ESR-U (ND) DR8ES-L (NGK)

#### • ATC200

DIMENSIONS	Overall length	1,835 mm (72.2 in)
	Wheel base	1,180 mm (46.5 in)
	Dry weight	142 kg (313.1 lb)
FRAME	Trail	5 mm (0.2 in)
ENGINE	Cylinder compression	11.0 ± 1 kg/cm <sup>2</sup> (156 ± 14 psi)
CARBURETOR	Pilot screw opening	2 1/8 turns out
ELECTRICAL	Spark plug	X24ESR-U (ND) DR8ES-L (NGK)

### TORQUE VALUES

#### ATC185S • ATC200

Item	Q'ty	Thread size (mm)	Torque	
			kg-m	ft-lb
Cylinder head nut	4	8	2.8-3.0	20-22

#### ATC200

Item	Q'ty	Thread size (mm)	Torque	
			kg-m	ft-lb
Inner brake drum cover nut	1	41	3.5-4.5	25-33
Brake drum drain bolt	1	6	0.7-1.2	5-9
Brake drum cover bolt	6	14	6.0-8.0	43-58



## MAINTENANCE SCHEDULE

Perform the PRE-RIDE INSPECTION in the Owner's Manual at every maintenance period.

### REGULAR MAINTENANCE SCHEDULE

- I: Inspect, Clean, Adjust, Lubricate or Replace if necessary.  
 C: Clean  
 R: Replace  
 A: Adjust

	ITEM	INITIAL SERVICE PERIOD (First week of operation)	REGULAR SERVICE PERIOD (Every 30 operating days)	Ref. Page
	ENGINE OIL (NOTE 1, 2)	R	R	2-2
*	ENGINE OIL FILTER SCREEN	C	C	2-2
	AIR CLEANER ELEMENT (NOTE 2)		I	3-3
	SPARK PLUG		I	3-4
*	VALVE CLEARANCE	I	I	3-5
*	CAM CHAIN TENSIONER	A	A	3-6
*	CARBURETOR	I	I	3-6
	FUEL LINE	I: (EVERY YEAR)		3-6
*	FUEL STRAINER	C: (EVERY YEAR)		3-7
	THROTTLE OPERATION	I	I	3-7
	DRIVE CHAIN	I	I	3-9
*	BRAKE SHOES	I: (EVERY YEAR)		3-11
	BRAKE CONTROL LINKAGE	I	I	3-11
*	CLUTCH	A	A	19-9
*	SPARK ARRESTER		C	3-13
	ALL NUTS, BOLTS, FASTENERS	I	I	3-14
	LIGHTING EQUIPMENT	I	I	3-14
	TIRES	I	I	3-14
*	STEERING HEAD BEARING	A: (EVERY YEAR)		3-15

- NOTES: 1. Replace every 30 operating days or every 3 months, whichever comes first.  
 2. Service more frequently when riding in dusty areas.



## CABLE AND HARNESS ROUTING

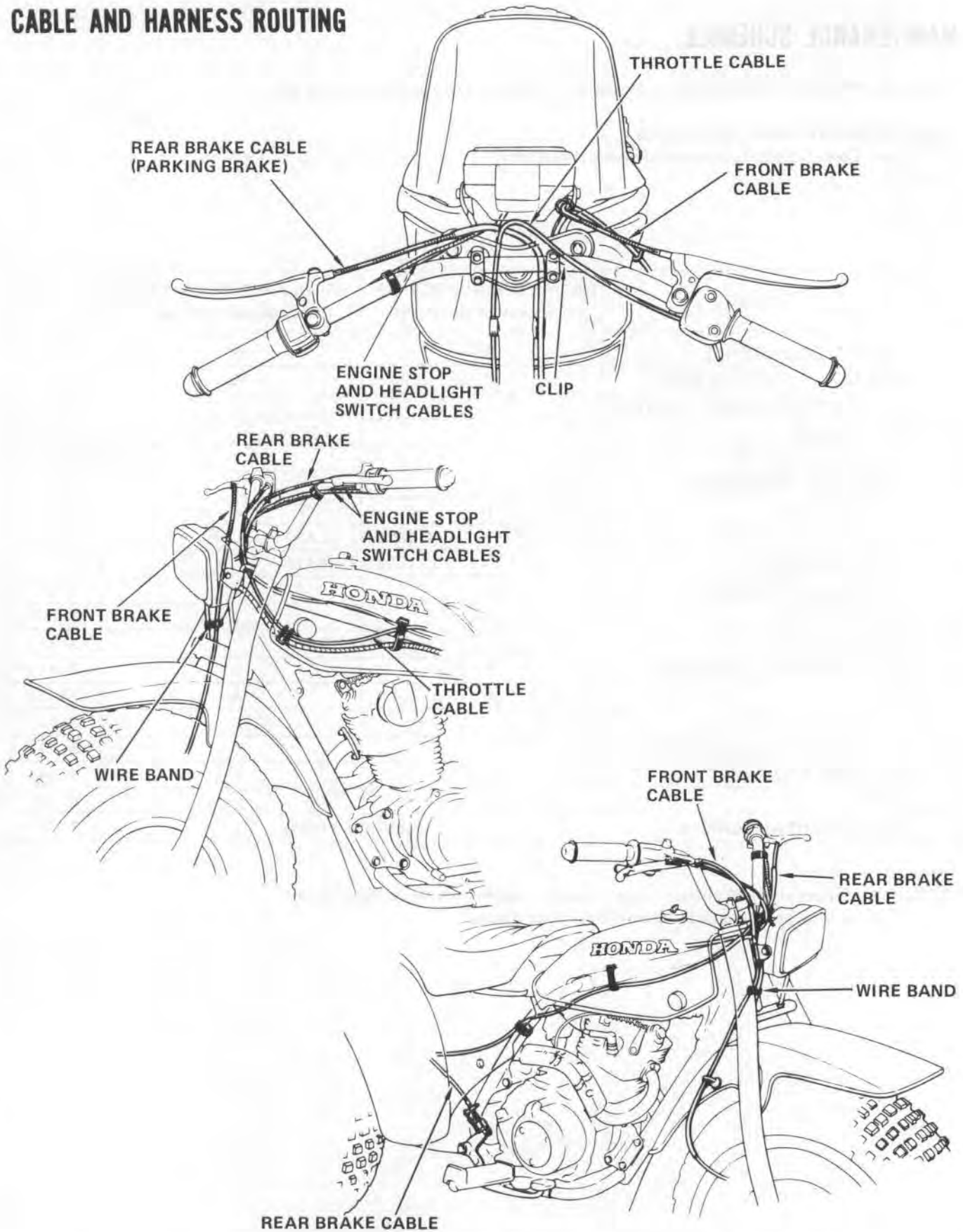



## 2. LUBRICATION

### OIL RECOMMENDATION

Use HONDA 4-STROKE OIL or equivalent.  
API SERVICE CLASSIFICATION: SE or SF  
VISCOSITY:  
SAE 10W-40

Other viscosities shown in the chart may be used when the average temperature in your riding area is within the indicated range.

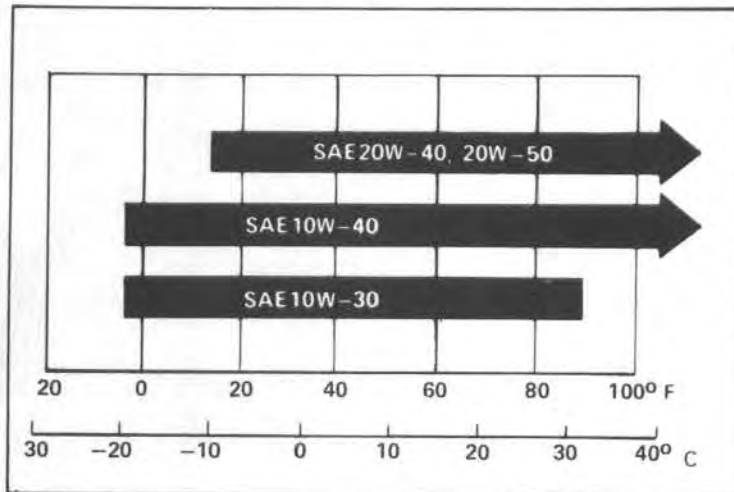

## 3. INSPECTION/ADJUSTMENT

### AIR CLEANER AND CASE

Remove the rear fender. (With the ATC200, remove the seat.)

Remove the air cleaner case cover and seal.

Remove the three case attaching bolts and loosen the air cleaner connecting tube band and clamp.

Remove the air cleaner case.

Remove the nut, then remove the air cleaner element from the case.

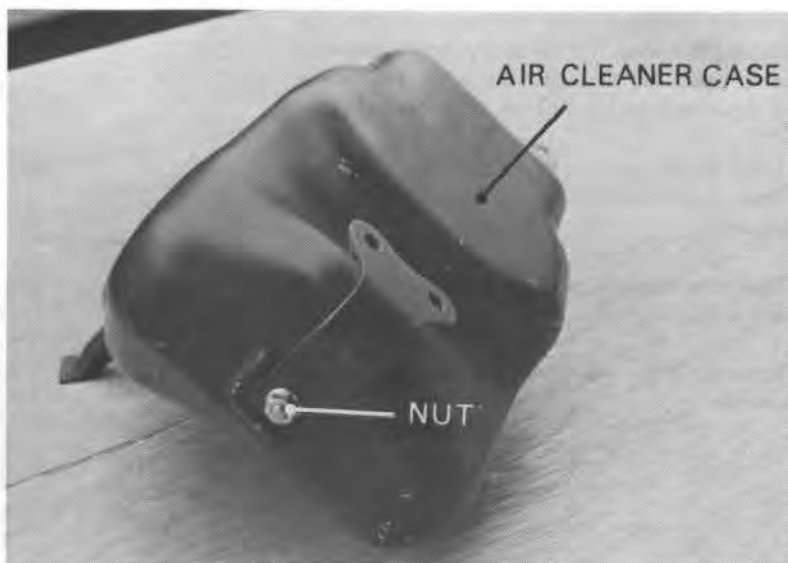
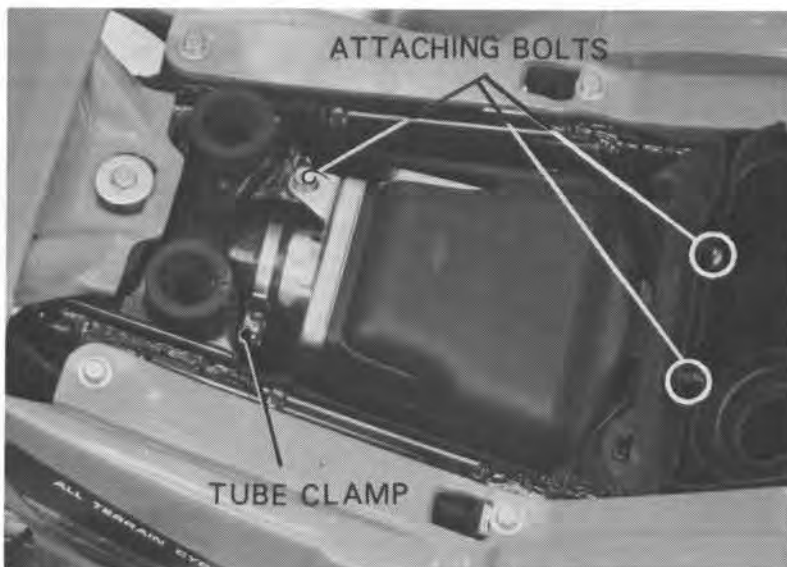



Remove the foam element.

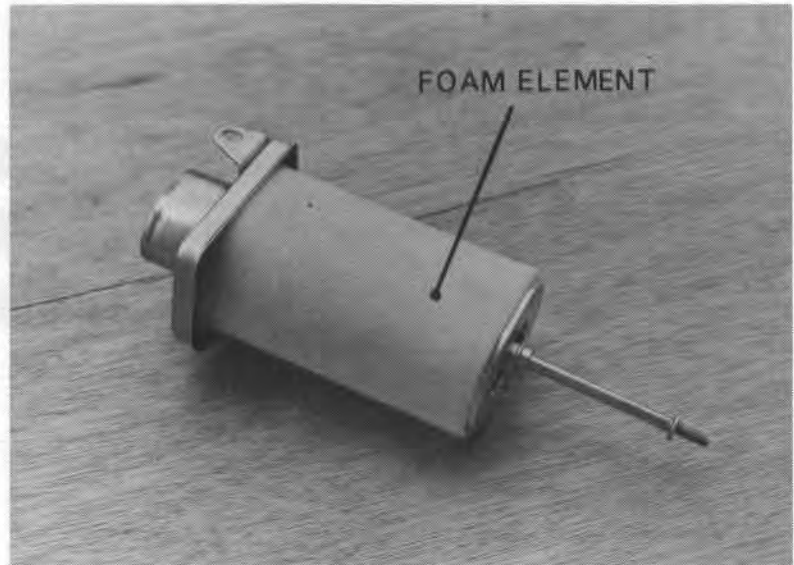

Wash the foam element in liquid detergent and water.

Rinse the element in clean water and allow it to dry thoroughly.

Soak the foam element in clean gear oil (SAE 80-90) until saturated. Squeeze out the excess oil.

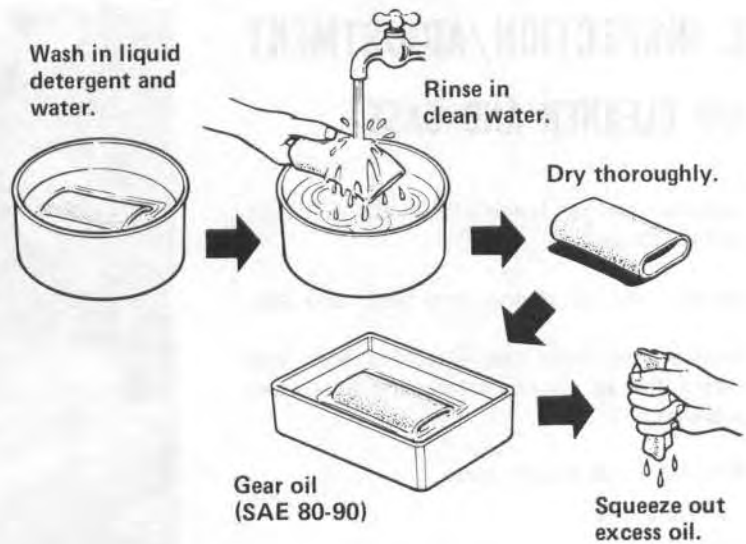

Remove the dust from the paper element by tapping the case lightly or by gently blowing compressed air through the filter. Direct the air from the inside out as much as possible.

If the paper element is excessively dirty, replace it or wash it in liquid detergent and water.

Rinse the element in clean water and allow it to dry thoroughly.

Reassemble by reversing the disassembly sequence.

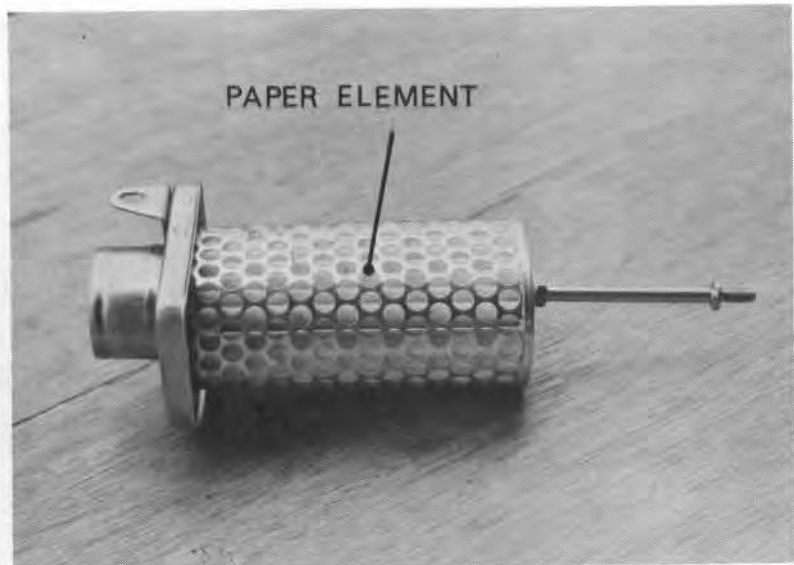





## HIGH ALTITUDE ADJUSTMENT

The carburetor must be adjusted for high altitude riding (above 2,000 m/6,500 ft).

### STANDARD SETTING:

2,000 m (6,500 ft) maximum

### HIGH ALTITUDE SETTING:

1,500 m (5,000 ft) minimum

[ ] = ATC200

	Standard (2,000 m/6,500 ft max)	High altitude (1,500 m/5,000 ft min)
Identification number	PD35D [PD35C]	←
Main Jet	# 100 [# 105]	# 92 [# 90]
Pilot screw opening	2 turns out [2 1/8]	1/4 turn clockwise from standard
Jet needle	Second groove	First groove

### ADJUSTMENT

Remove and disassemble the carburetor and throttle valve (page 4.6–4.8).

Replace the standard main jet with the high altitude type, and relocate the jet needle clip. Adjust the pilot screw.

Reassemble and reinstall the carburetor and throttle valve.

**CAUTION:** Sustained operation below 1,500 m (5,000 ft) with the high altitude settings may cause engine damage. Install the main jet, return the jet needle clip to the 2nd groove and pilot screw to the factory preset position when riding below 1,500 m (5,000 ft).

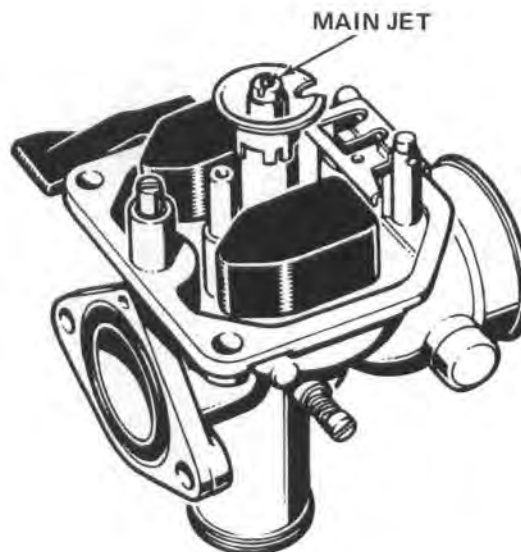



## 4. FRONT WHEEL/BRAKE/STEERING

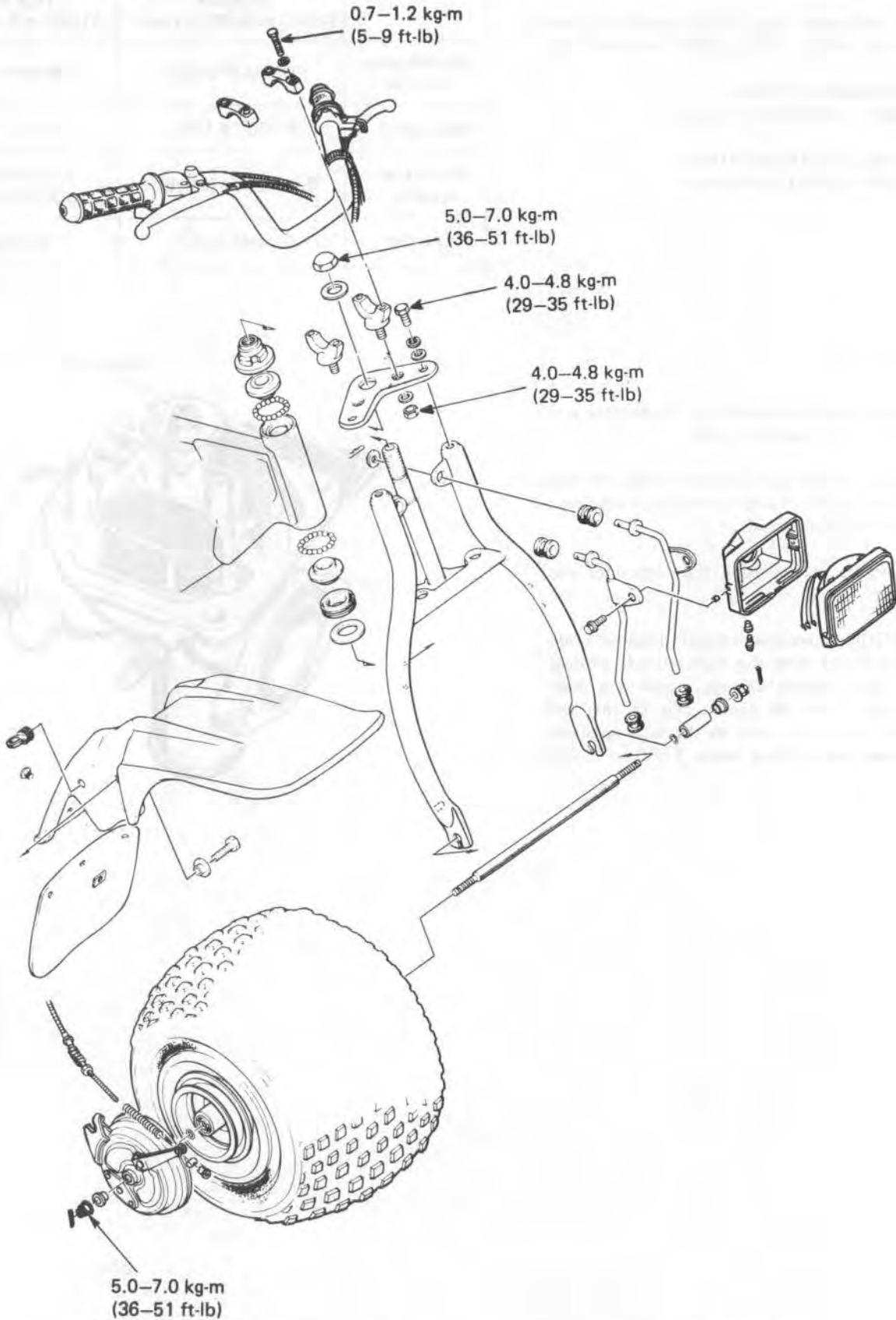



## FRONT WHEEL

### REMOVAL

Raise the front wheel off the ground by placing a block or safety stand under the engine.

Disconnect the front brake cable.

Remove the cotter pins from both sides of the axle shaft.

Remove the axle nuts from both sides.

Remove the front axle collars and remove the front wheel.

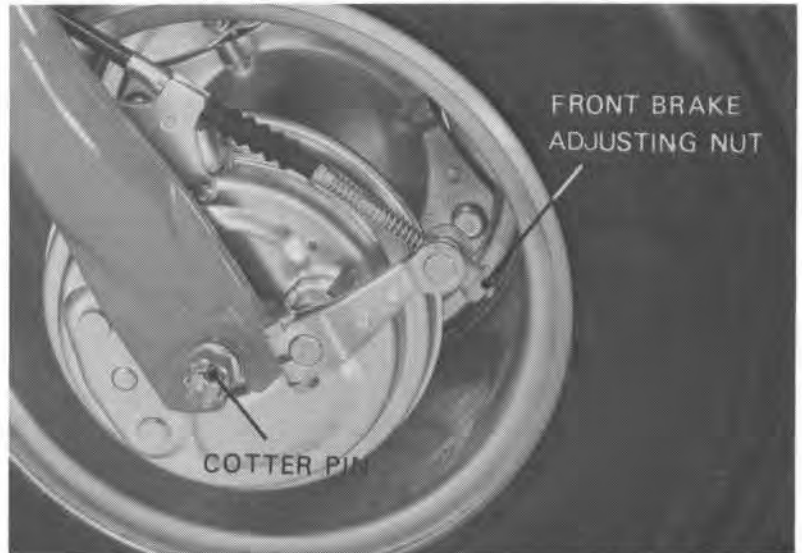

### INSTALLATION

Position the front wheel between the fork legs aligning the tab on the right fork with the groove in the brake panel.

Tighten the two axle nuts.

**TORQUE: 5.0–7.0 kg-m (35–51 ft-lb)**

Install new cotter pins and bend the ends securely.

Connect the front brake cable and adjust the front brake lever free play (Page 3–11).

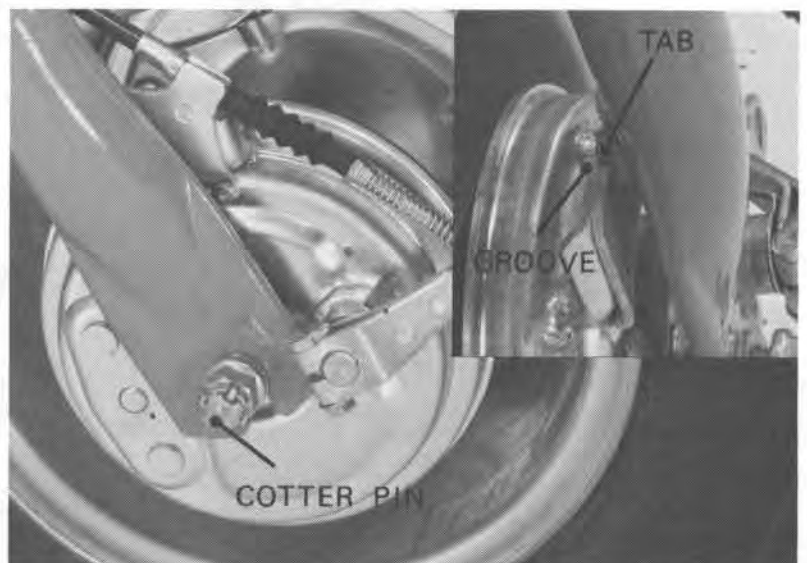



## 5. REAR WHEEL/BRAKE/DRIVE MECHANISM

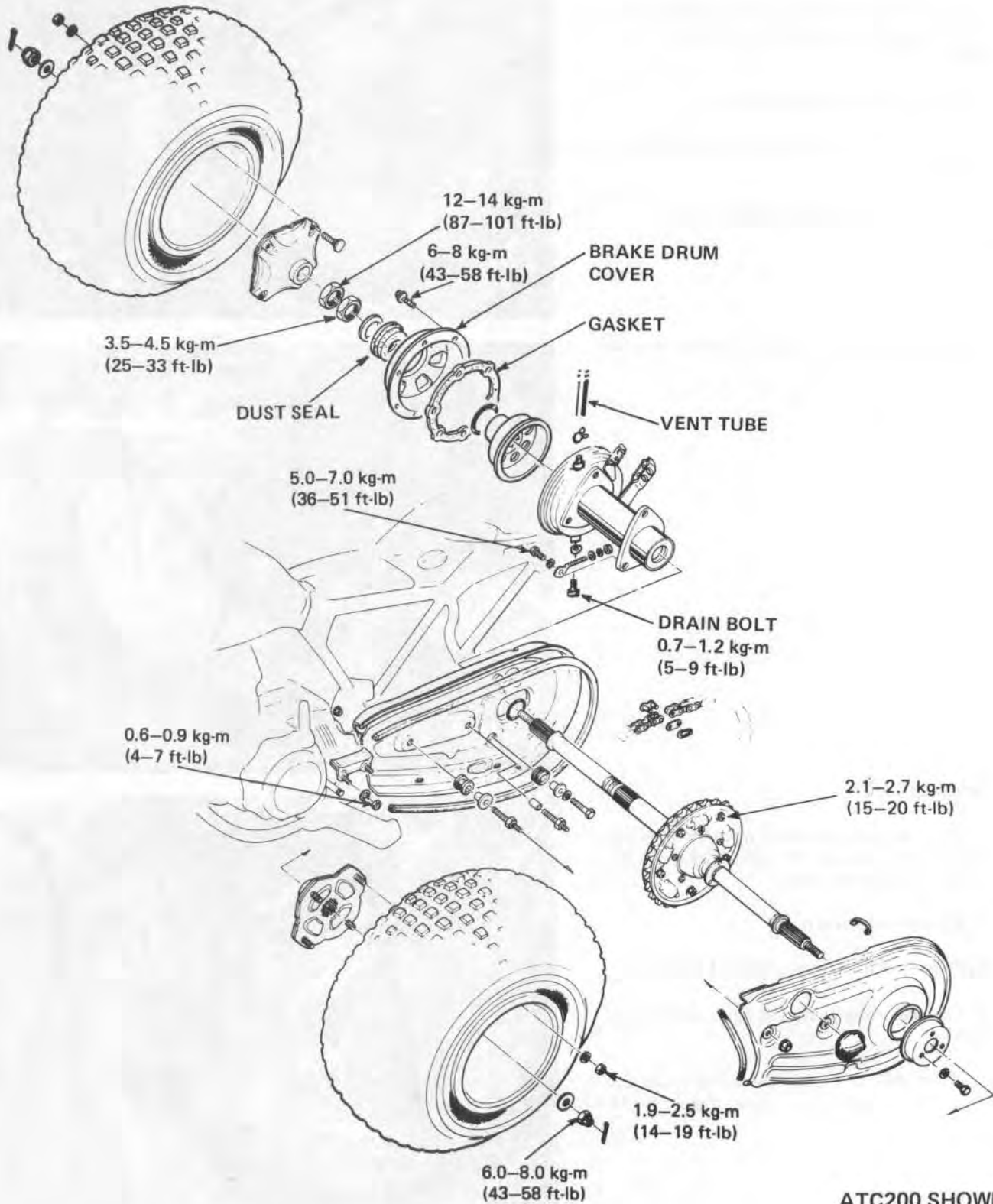



## REAR WHEEL (ATC200)

### REMOVAL

Raise the rear wheels off the ground with a jack or block under the engine.

Remove the cotter pin and remove the axle nut.

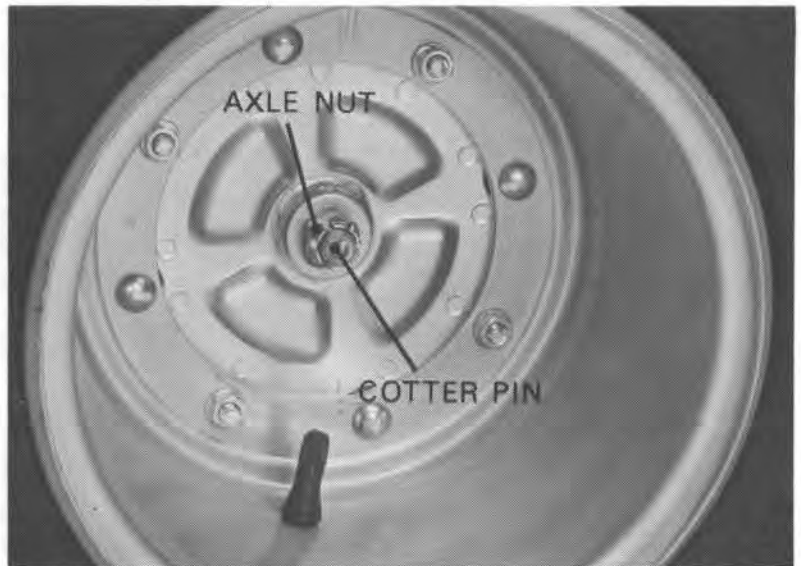

## REAR BRAKE (ATC200) BRAKE DRUM COVER REMOVAL

Apply the parking brake.

Remove the brake drum cover nuts.



Remove the bolts and the brake drum cover.

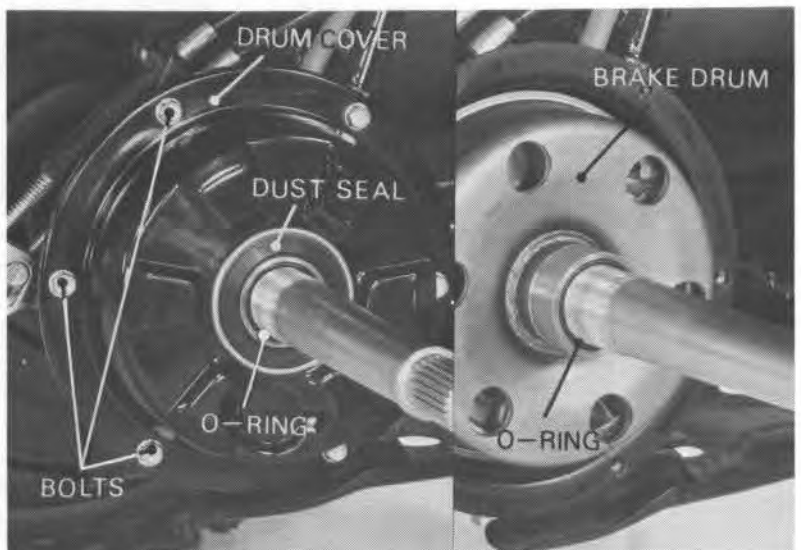



Remove the dust seal.

Check the brake drum cover gasket and dust seal for damage.

Replace if necessary.



**ASSEMBLY**

Lubricate the inside of the dust seal with grease.

Drive the dust seal squarely into the brake drum cover.



Install the gasket on the cover and reinstall the cover.

Tighten the bolts in two or more steps in a criss-cross pattern.

**TORQUE: 6-8 kg-m (43-58 ft-lb)**

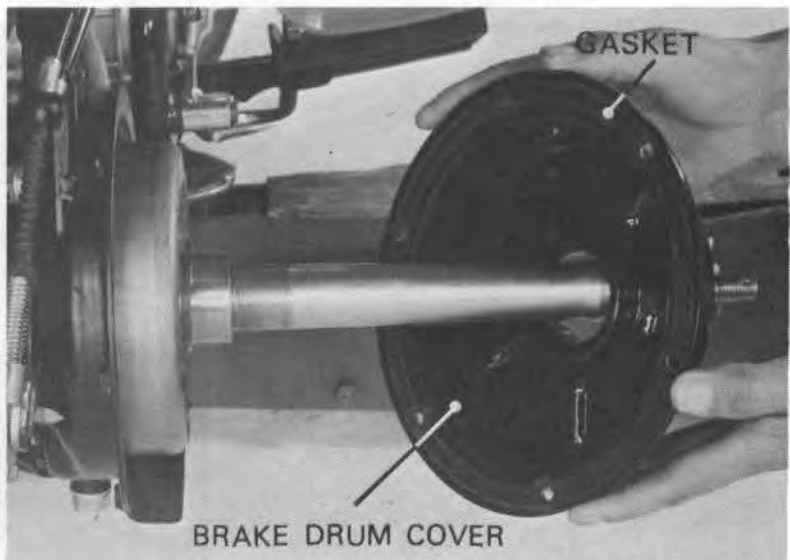



Install the tapered washer and the inner cover nut.

Tighten the brake drum nut.

**TORQUE: 3.5-4.5 kg-m (25-33 ft-lb)**

Wipe any grease off the shaft and apply **LOCTITE®** or an equivalent to the shaft.

Install and tighten the brake drum outer nut while holding the inner nut with a wrench.

**TORQUE: 12-14 kg-m (87-101 ft-lb)**

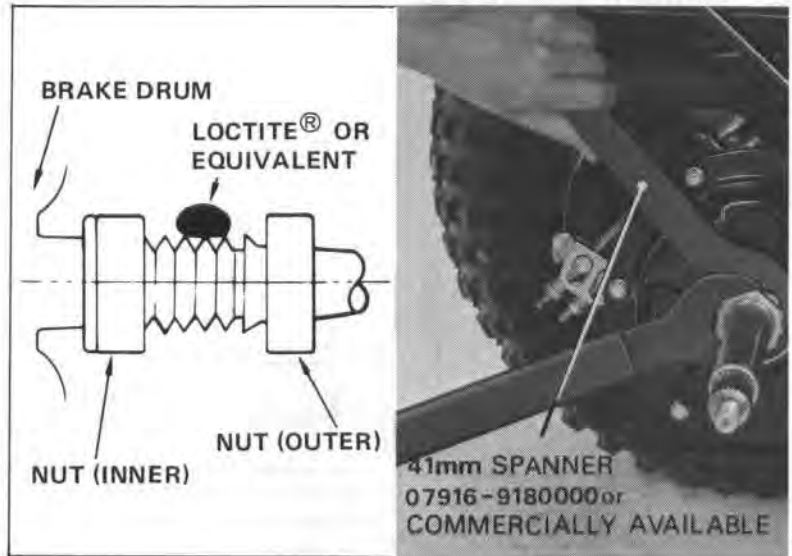

## DRIVE MECHANISM (ATC200)

The drive chain on this motorcycle is equipped with small grease-retaining O-rings inside the chain to improve its service life. However, special precautions must be taken when adjusting, lubricating, washing and replacing the chain.

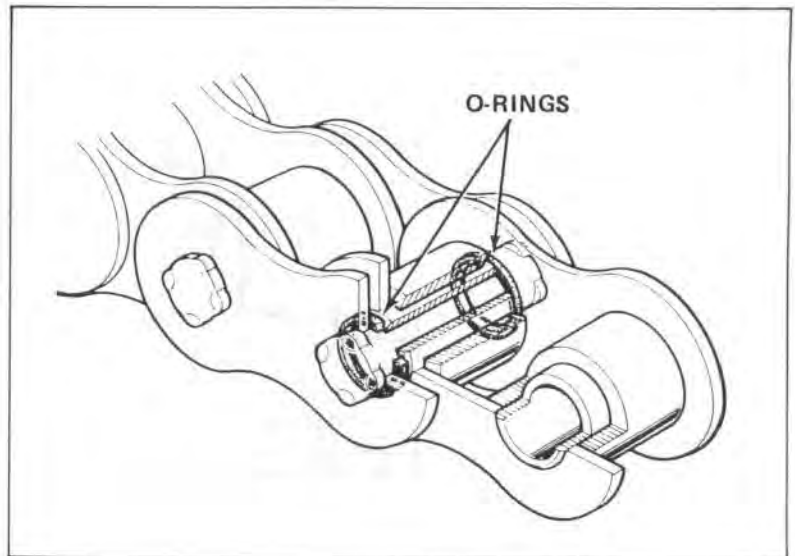

The O-rings can be damaged by steam cleaning, high pressure washers, and certain solvents.

Clean the chain with kerosene. Wipe dry and lubricate only with SAE 80 or 90 gear oil. Commercial chain lubricants may contain solvents which could damage the rubber O-rings.

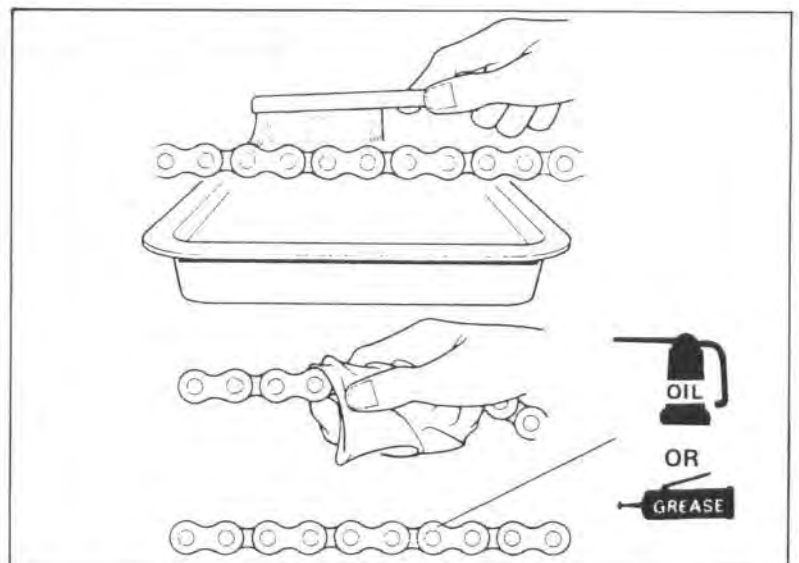



**6. WIRING DIAGRAM**

IGNITION SWITCH CONTINUITY

	IG	E
OFF	○	○
ON		
COLOR	Bk	G

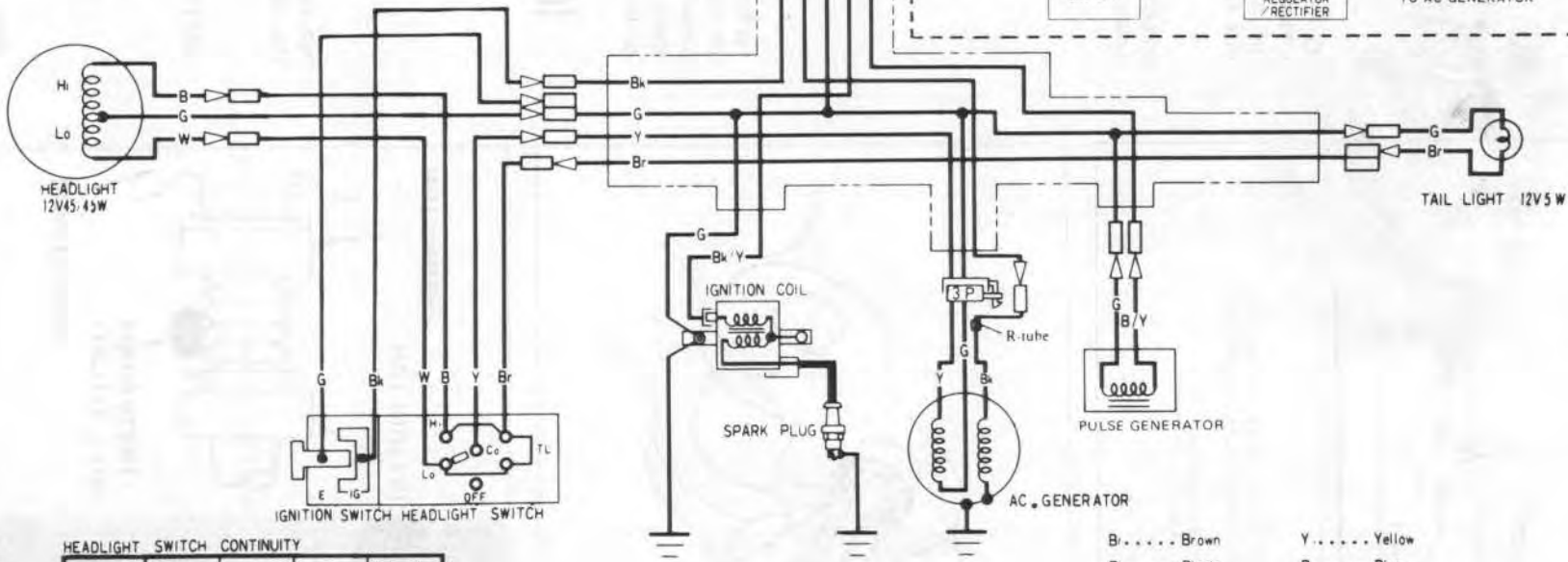

HEADLIGHT SWITCH CONTINUITY

	HL - L	Co	TL	HL - Hi
OFF				
Lo	○	○	○	
Hi		○	○	○
COLOR	W	Y	Br	B

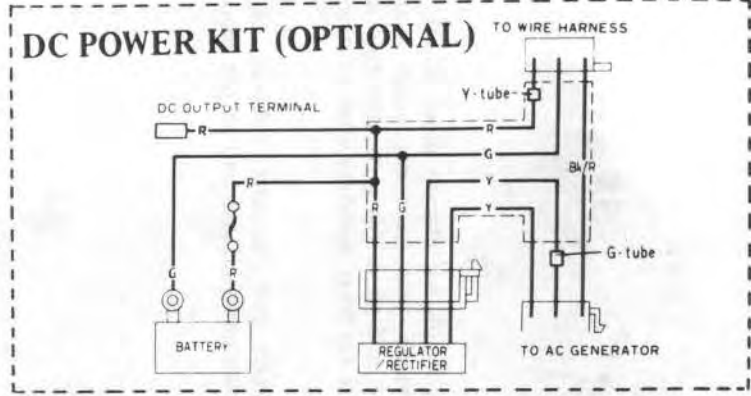

- Bk . . . . . Black
- W . . . . . White
- LG . . . . . Light Green
- R . . . . . Red
- G . . . . . Green
- Y . . . . . Yellow
- B . . . . . Blue
- Gr . . . . . Grey
- LB . . . . . Light Blue
- O . . . . . Orange
- P . . . . . Pink





## 7. RECOIL STARTER

### DISASSEMBLY

Disconnect the decompression cable at its upper end and remove the recoil starter from the ATC (page 9-2).

Remove the four recoil packing plate screws and plate.

Slide the decompression outer cable out of the rubber seal far enough to clear the hook case.

Lift the hook case far enough to disengage the friction spring from the hook plate and case. Then remove the hook case.

Remove the hook plate cushion, hook plate and decompression cable from the hook case.

Disconnect the cable from the hook plate and remove from the recoil case.

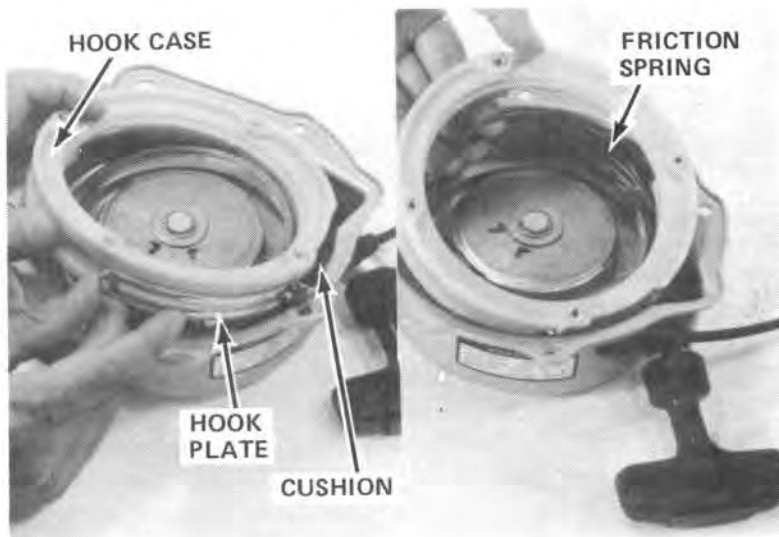
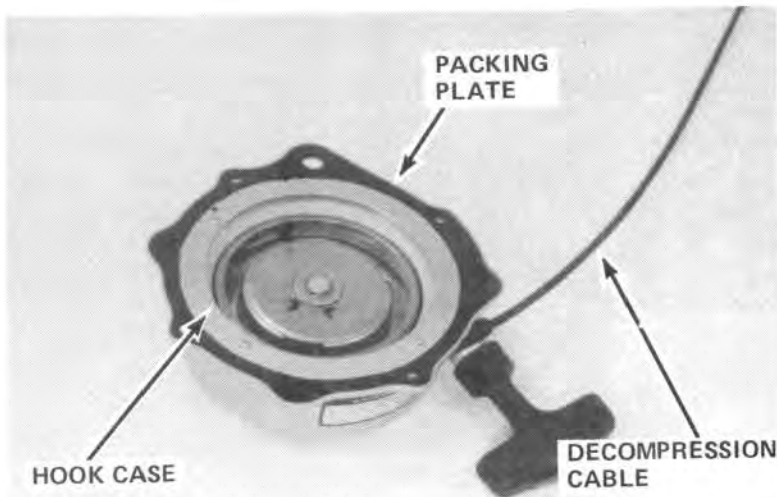

Remove the ratchet cover circlip.

Remove the thrust washer and ratchet cover.

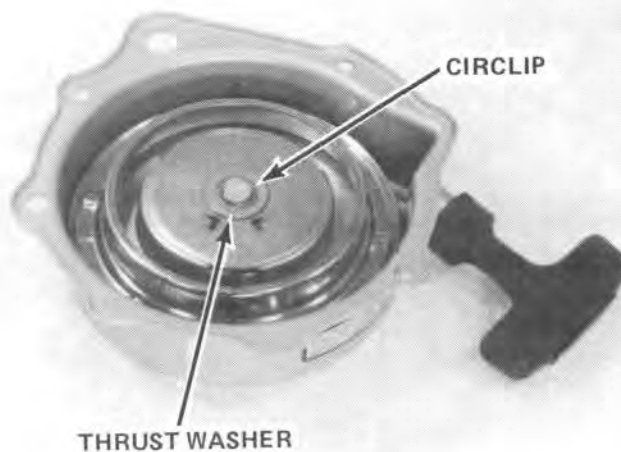



Remove the ratchets and ratchet springs.

Remove the center spring and thrust washer.

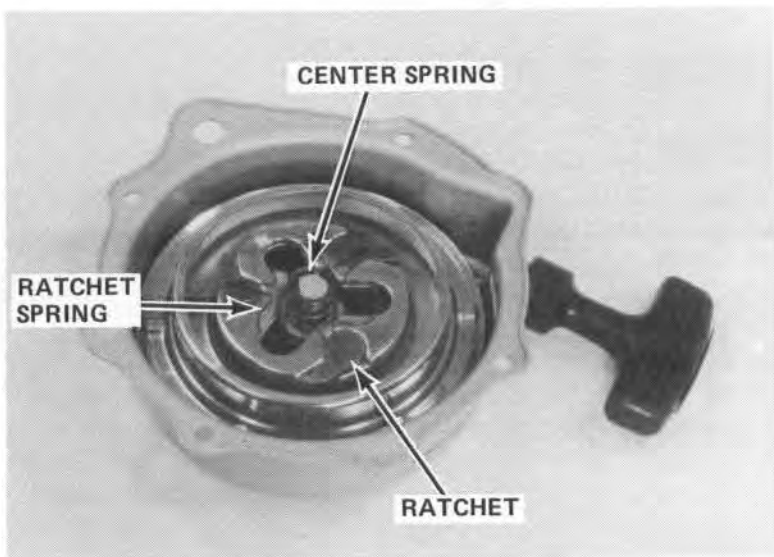

Remove the starter grip.

Release the starter rope slowly.

Remove the starter drive pulley by turning the pulley counterclockwise.

**WARNING**

Wear eye protection and use care when removing the drive pulley and starter spring. The spring can pop out of the housing, if care is not used.

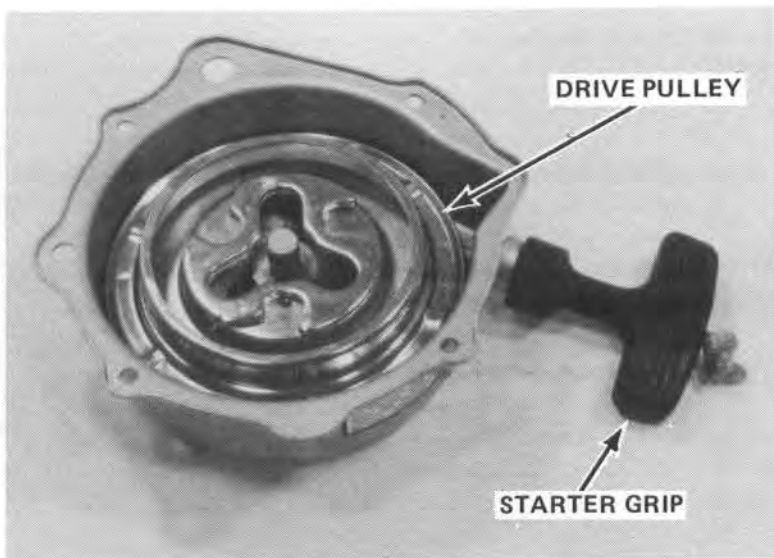

Check the recoil starter spring.

Remove the recoil spring, if necessary.

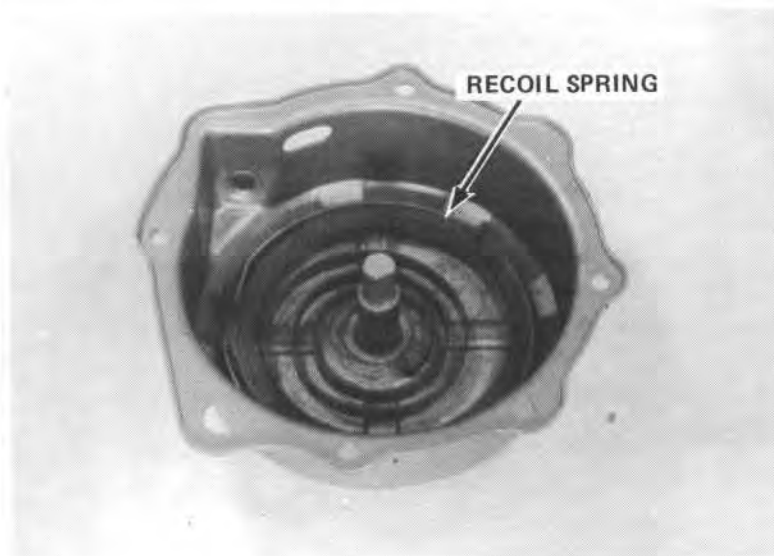



**RECOIL STARTER INSPECTION**

- Check the starter rope for wear or damage.
- Check the starter ratchet for wear or damage.
- Check the ratchet spring for damage.
- Replace any damaged parts.

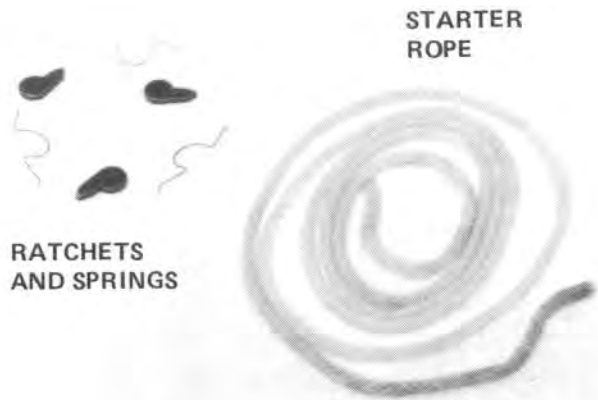

**DECOMPRESSION SYSTEM INSPECTION**

- Check the decompression cable for damage or wear and that the inner cable is not binding.
- Check the friction spring for damage or wear on its inside surface. Also check the drive pulley outer surface for wear. If the plating is coming off of the drive pulley, it should be replaced, or the pulley will stick during operation.

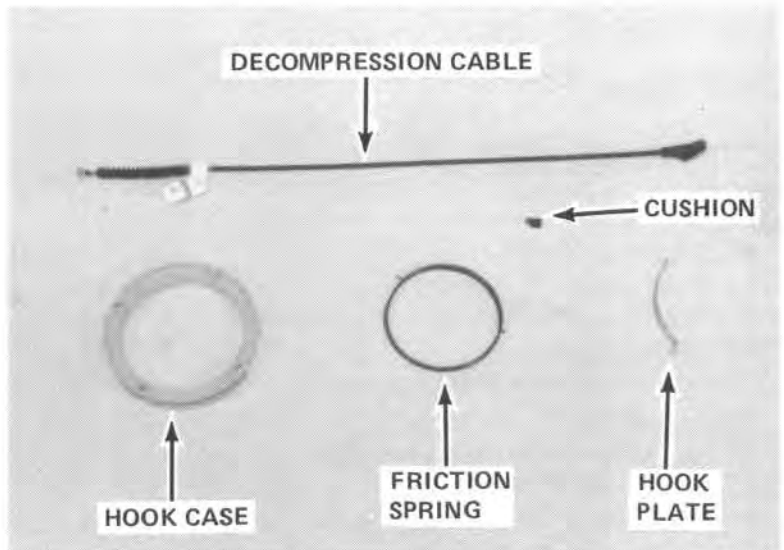

**REASSEMBLY**

- Install the starter rope and tie a knot as shown.





Wrap the rope around the starter pulley in a clockwise direction as viewed from the ratchet side as shown.

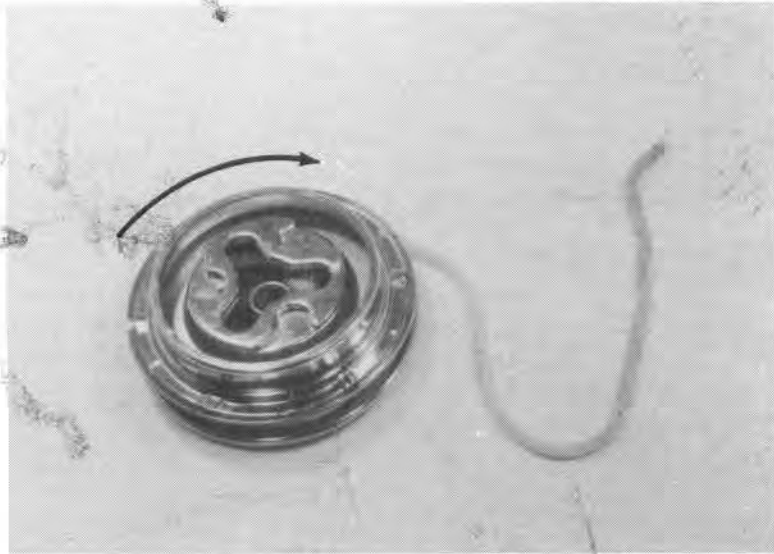

Apply grease to the pulley shaft.

Install the spring by hooking the end with the starter housing hook.

**WARNING**

Wear eye protection and use care when installing the drive pulley and starter spring. The spring can pop out of the housing, if care is not used.

Install the starter pulley by turning it clockwise to align the spring end with the starter pulley boss.

Route the starter rope through the pulley cut-out.

Preload the starter spring by turning the pulley 2 turns counter-clockwise.

Route the rope end through the starter housing hole and install the grip.

Apply grease to the ratchets.

Install the ratchets and ratchet springs.

Coat the thrust washer with grease and install it and the center spring.

Install the ratchet cover, thrust washer and circlip.

Check recoil starter operation by pulling the starter grip.

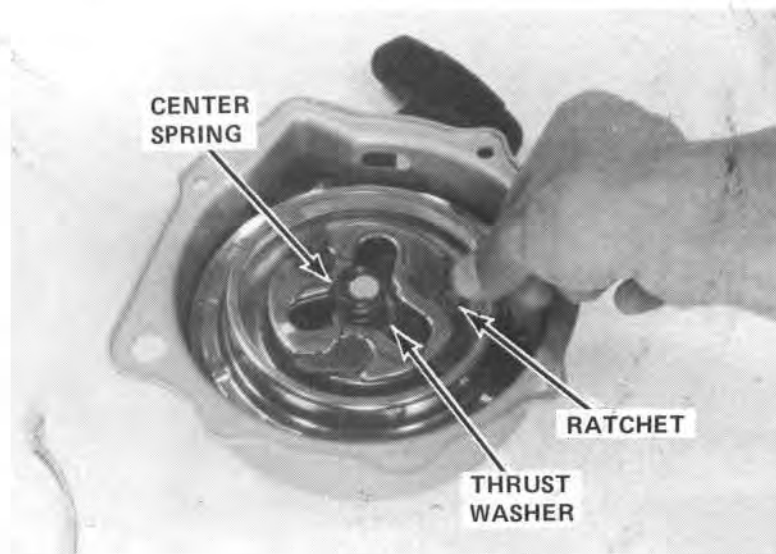
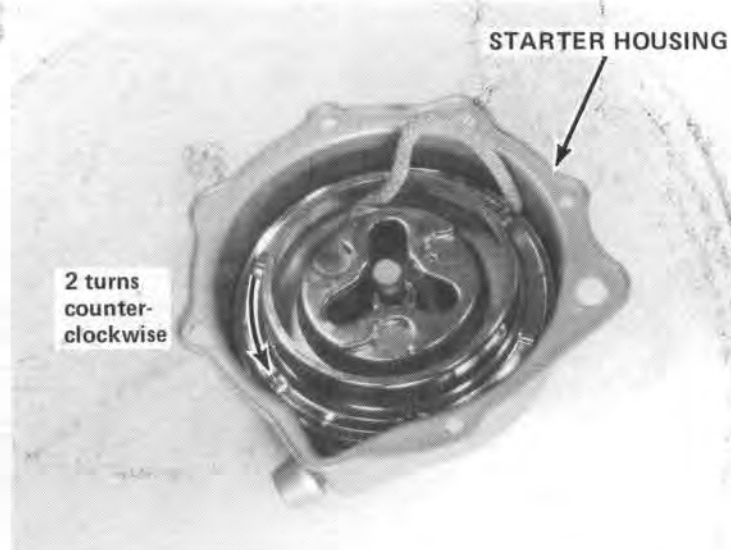



Coat the outer surface of the drive pulley where the friction spring fits with molybdenum disulfide grease.

Squeeze the ends of the friction spring toward each other and install the spring into the case. Leave the last 90° of the spring off of the drive pulley and positioned as shown. The rest of the spring should be completely on the drive pulley.

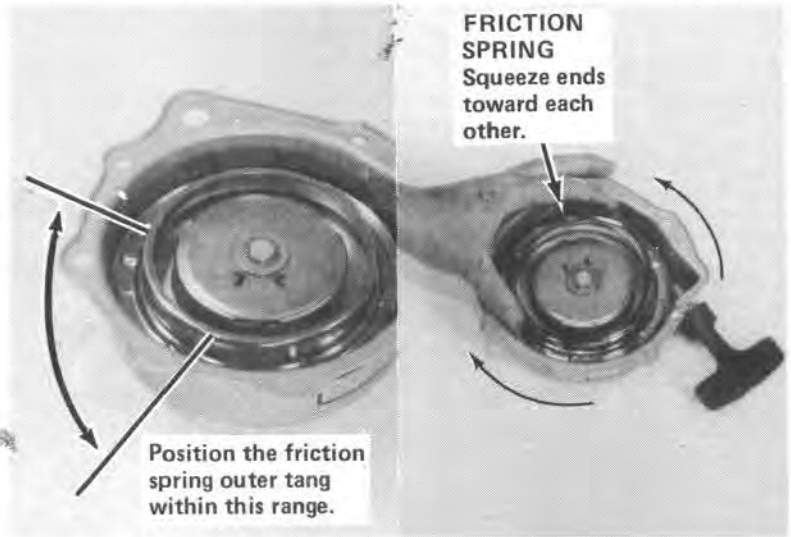

Apply a coating of molybdenum disulfide grease to the sliding surfaces of the hook case and hook plate.

Pass the decompression cable through the starter housing.

**NOTE**

The decompression outer cable should not be past the inner surface of the rubber seal.

Install the end of the inner cable in the hook plate and install the plate, cable and cushion into the case. Be sure the hook plate is over the guide tab.

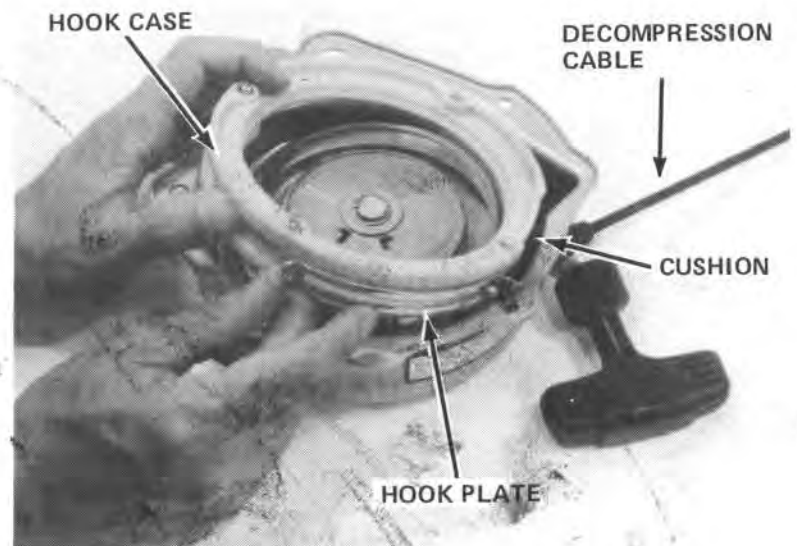

Hook the outer tang of the friction spring into the hook case. Install the hook case onto the recoil cover.

Make sure the friction spring is on the drive pulley and not binding on the hook case by pulling the starter grip.

Install the packing plate and extend the decompression cable. Check operation of the recoil starter and decompression mechanism by operating the recoil starter 2-3 times.

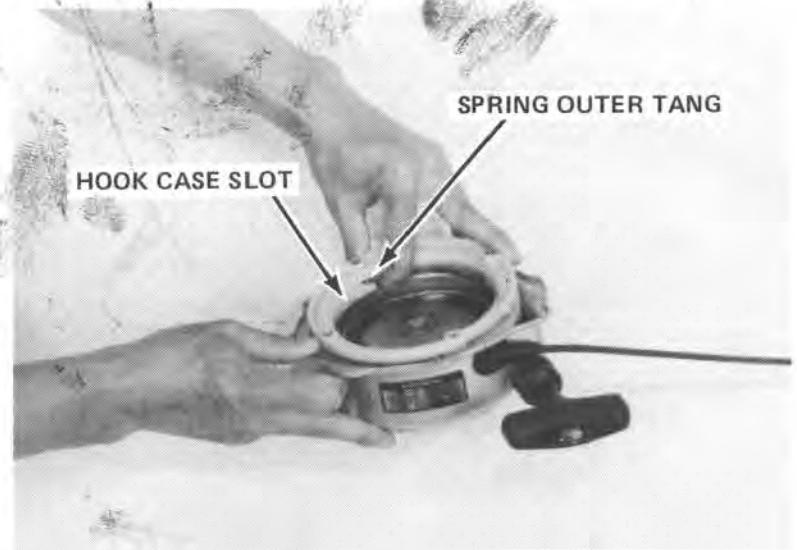

**NOTE**

- It may take one pull to seat the cable, hook plate and hook case.
- Extend the decompression cable after each pull.





## INTRODUCTION

This addendum contains service information for the '83 ATC185S and ATC200.

Refer to the base Shop Manual for service information not described in this addendum.

## CONTENTS

1. GENERAL INFORMATION .....	21-2
— Specifications .....	21-2
— Cable and Harness Routing .....	21-4
— Maintenance Schedule .....	21-5
2. LUBRICATION .....	21-6
— Oil Recommendation .....	21-6
3. INSPECTION AND ADJUSTMENT .....	21-6
— Air Cleaner and Case .....	21-6
— High Altitude Adjustment .....	21-7
4. FRONT WHEEL/SUSPENSION .....	21-8
— Front Wheel .....	21-8
— Front Suspension .....	21-8
5. DRIVE CHAIN AND SEALED BRAKE .....	21-12
6. WIRING DIAGRAM .....	21-13



# 1. GENERAL INFORMATION

## SPECIFICATIONS

ITEM		ATC185S	ATC200	
DIMENSIONS	Overall length	1,720 mm (67.7 in)	1,840 mm (72.4 in)	
	Overall width	1,000 mm (39.4 in)	1,080 mm (42.5 in)	
	Overall height	980 mm (38.6 in)	1,005 mm (39.6 in)	
	Wheel base	1,120 mm (44.1 in)	1,190 mm (46.9 in)	
	Rear tread	745 mm (29.3 in)	800 mm (31.5 in)	
	Seat height	665 mm (26.2 in)	690 mm (27.2 in)	
	Foot peg height	260 mm (10.2 in)	280 mm (11.0 in)	
	Ground clearance	120 mm ( 4.7 in)	125 mm ( 4.9 in)	
	Dry weight	122.5 kg (270 lb)	136 kg (300 lb)	
FRAME	Type	Semi-double cradle	←	
	Rim size	Front	8.25 x 8.0	9.25 x 9.0
		Rear	8.25 x 8.0	9.25 x 9.0
	Tire	Front size, pressure	22 x 11.0-8, 0.15 kg/cm <sup>2</sup> (2.2 psi)	25 x 12-9, 0.15 kg/cm <sup>2</sup> (2.2 psi)
		Rear size, pressure	22 x 11.0-8, 0.15 kg/cm <sup>2</sup> (2.2 psi)	25 x 12-9, 0.15 kg/cm <sup>2</sup> (2.2 psi)
		Standard circumference	1,743 mm (68.6 in)	1,920 mm (75.6 in)
		Front brake	Cable operated leading shoe	←
		Rear brake	Cable operated leading shoe	←
		Fuel capacity	8.8 liters (2.3 US gal, 1.9 Imp gal)	←
		Fuel reserve capacity	1.6 liters (0.42 US gal, 0.35 Imp gal)	←
		Caster	69°5'	69°
		Trail	30 mm (1.2 in)	10 mm (0.4 in)
	Front oil capacity	85—90 cc (3.0 oz)	←	
ENGINE	Type	Gasoline, air-cooled 4-stroke, OHC	←	
	Cylinder arrangement	Single cylinder inclined 15°	←	
	Bore x stroke	63.0 X 57.8 mm (2.48 x 2.28 in)	65.0 x 57.8 mm (2.56 x 2.28 in)	
	Displacement	180 cc (11.0 cu in)	192 cc (11.7 cu in)	
	Compression ratio	8.0:1	7.8:1	
	Valve train	Chain driven overhead camshaft	←	
	Maximum horsepower	12.9 BHP/7,000 rpm	←	
	Maximum torque	1.38 kg-m/5,500 rpm (9.26 ft-lb/5,500 rpm)	1.46 kg-m/5,500 rpm (10.6 ft-lb/5,500 rpm)	
	Oil capacity	1.35 liters (1.43 US qt, 1.19 Imp qt) 1.3 liters (1.37 US qt, 1.14 Imp qt) after draining	←	
	Lubrication system	Forced pressure and wet sump	←	
	Cylinder compression	11 ± 1.0 kg/cm <sup>2</sup> (156 ± 14 psi)	←	
	Intake valve	OPENS 5° BTDC CLOSES 35° ABDC	←	
	Exhaust valve	OPENS 35° BBDC CLOSES 5° ATDC	←	
	Valve clearance	Intake 0.05 mm (0.002 in) (Cold) Exhaust 0.05 mm (0.002 in)	←	
		←		
CARBURETOR	Type	Piston valve	←	
	Main jet	#98	#95	
	Pilot screw opening	1 turn out	1 1/4 turns out	
	Float level	12.5 mm (0.49 in)	←	
	Idle speed	1,400 ± 100 rpm	←	
	Venturi dia.	22 mm (0.9 in)	←	





ITEM		ATC185S	ATC200	
DRIVE TRAIN	Clutch	Wet multi-plate, semi-automatic	←	
	Transmission	5-speed constant mesh	←	
	Primary reduction	3.333:1	←	
	Gear ratio	I	2.769:1	←
		II	1.722:1	←
		III	1.273:1	←
		IV	1.000:1	←
		V	0.815:1	←
	Final reduction	3.727:1	4.273:1	
Gear shift pattern	Left foot operated return system, N-1-2-3-4-5	←		
Drive chain	520, 82L	520, 90L		
ELECTRICAL	Ignition	C.D.I.	←	
	Ignition timing	Initial	10° ± 2° BTDC at idle	←
		Full advance	30° ± 2° BTDC at 3,350	←
	Alternator	Capacity	12V 50W/5,000 rpm	←
	Spark plug		X24ESR-U (ND) DR8ES-L (NGK)	←
	Spark plug gap		0.6—0.7 mm (0.024—0.028 in)	←
	Headlight		12V 45W/45W	←
Taillight		12V 5W	←	



## CABLE AND HARNESS ROUTING

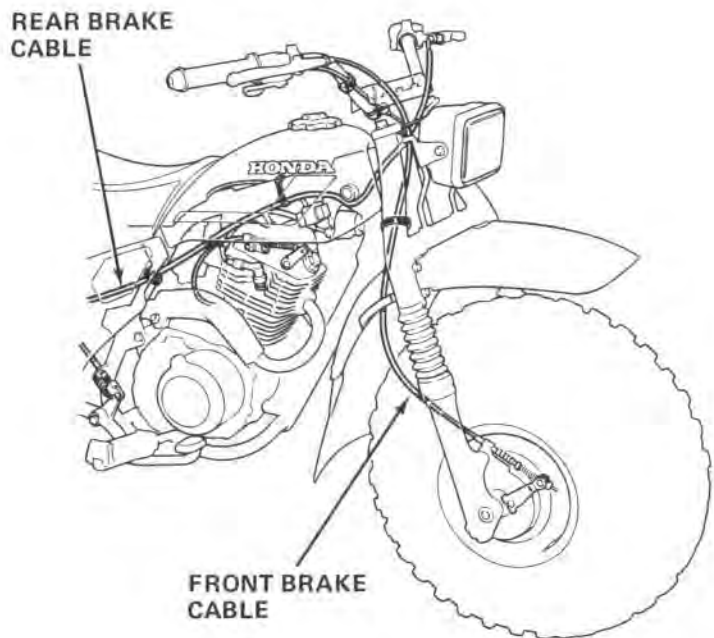
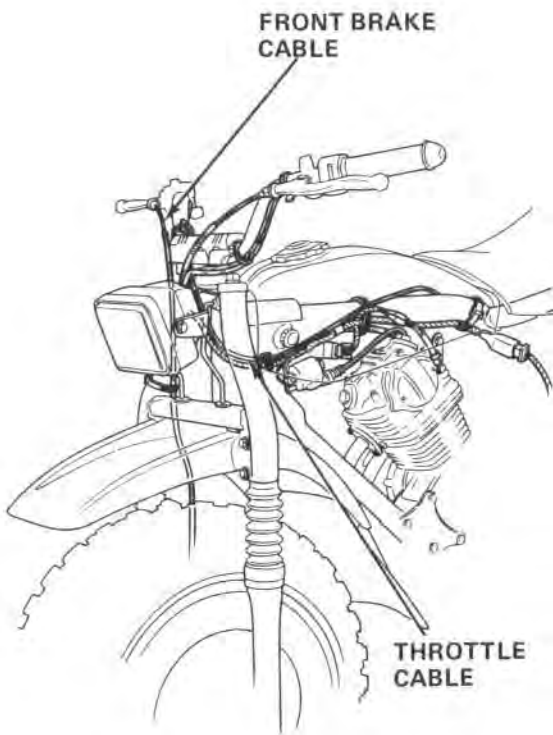
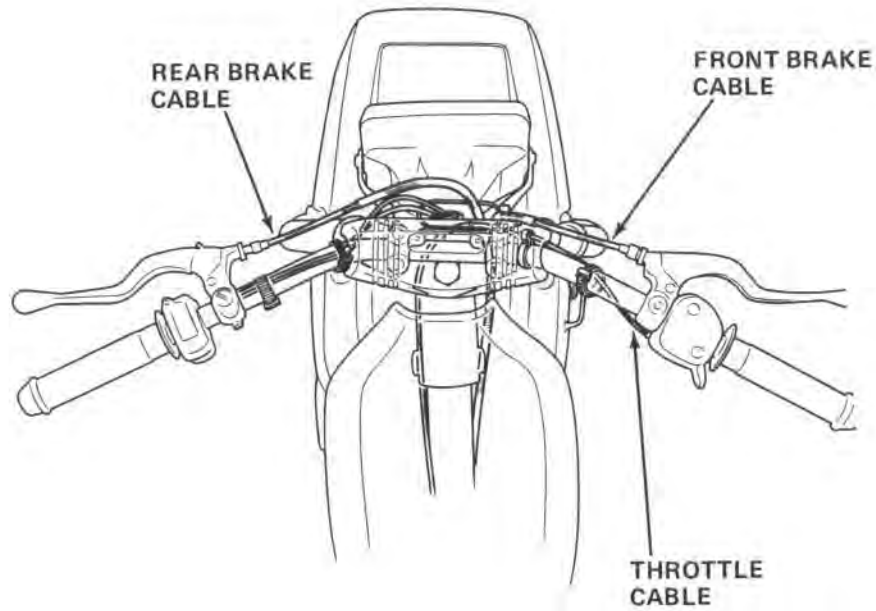



## MAINTENANCE SCHEDULE

Perform the PRE-RIDE INSPECTION at each scheduled maintenance period.

I: Inspect and Clean, Adjust, Lubricate, or Replace if necessary.

C: Clean

R: Replace

A: Adjust

L: Lubricate

ITEM	INITIAL SERVICE PERIOD (First week of operation)	REGULAR SERVICE PERIOD (Every 30 operating days)
ENGINE OIL (NOTE 1, 2)	R	R
* ENGINE OIL FILTER SCREEN	C	C
* ENGINE OIL FILTER ROTOR		C
AIR CLEANER ELEMENT (NOTE 2)		I
SPARK PLUG		I
* VALVE CLEARANCE	I	I
* CAM CHAIN TENSIONER	A	A
* CARBURETOR	I	I
FUEL LINE		I: (EVERY YEAR)
* FUEL FILTER		C: (EVERY YEAR)
THROTTLE OPERATION	I	I
* FRONT FORK OIL		R: (EVERY YEAR)
DRIVE CHAIN	I	I
* BRAKE SHOES		I: (EVERY YEAR)
BRAKE CONTROL LINKAGE	I	I
* CLUTCH	A	A
* SPARK ARRESTER		C
ALL NUTS, BOLTS, FASTENERS	I	I
LIGHTING EQUIPMENT	I	I
TIRES	I	I
* STEERING HEAD BEARINGS		A: (EVERY YEAR)

\* In the interest of safety, we recommend these items be serviced by an authorized Honda dealer.

NOTES: 1. Replace every 30 operating days or every 3 months, whichever comes first.

2. Service more frequently when riding in dusty areas.



## 2. LUBRICATION

### OIL RECOMMENDATION

Use Honda 4-Stroke Oil or equivalent.  
API Service Classification: SE or SF  
Viscosity: SAE 10W-40

Other viscosities shown in the chart may be used when the average temperature in your riding area is within the indicated range.

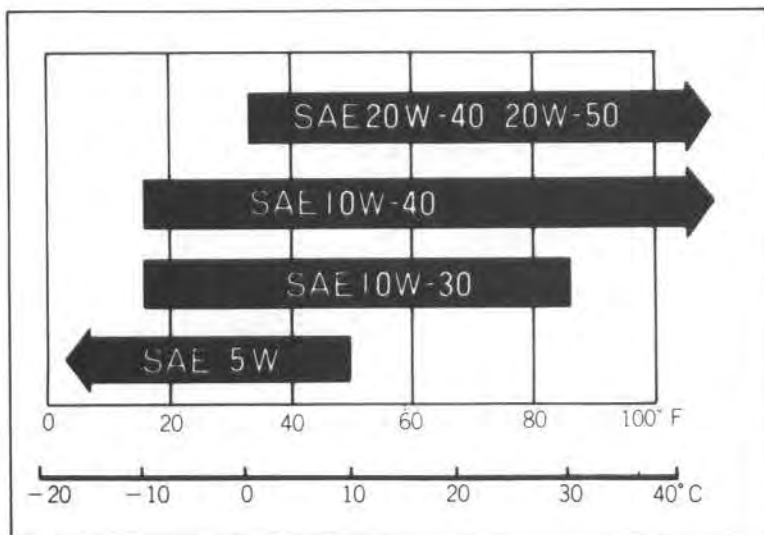

## 3. INSPECTION/ ADJUSTMENT

### AIR CLEANER AND CASE

- Remove the rear fender (ATC185S).
- Remove the seat (ATC200).
- Remove wing bolts and air cleaner cover.

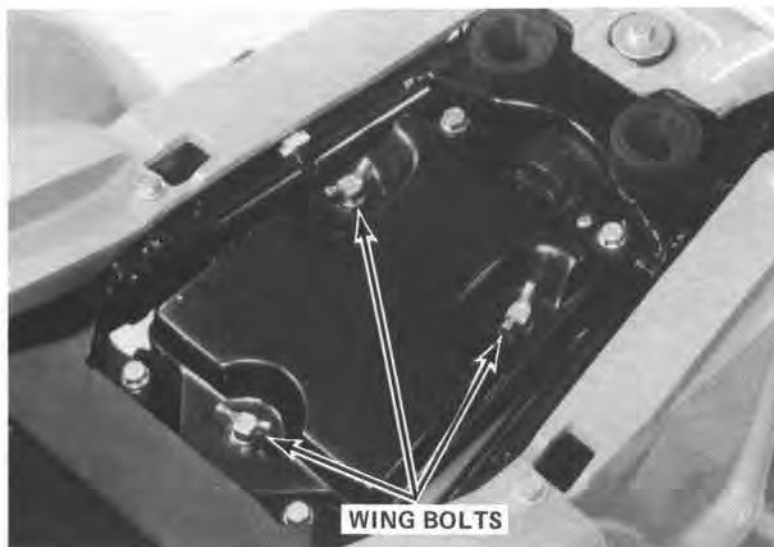

- Loosen the air cleaner band screw and remove the air cleaner element from the case.
- Remove the retainer from the air cleaner holder element and remove the element.

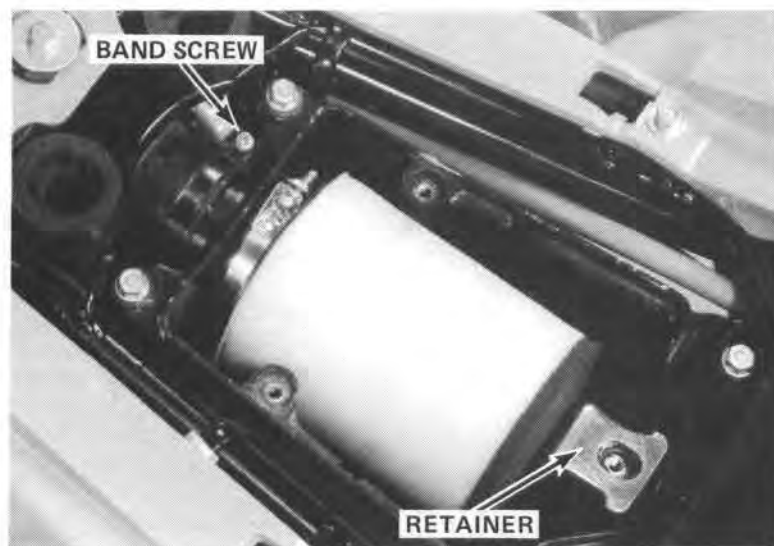



**'83 ADDENDUM**

Wash the element in non-flammable or high flash point solvent, squeeze out the solvent thoroughly, and allow to dry.

Soak the element in gear oil (SAE 80—90) and squeeze out excess. Place the element onto the element holder.

Install the retainer onto the element holder.

Install the element holder into the air cleaner case. Tighten the band screw securely.

Install the air cleaner case cover with the wing bolts.

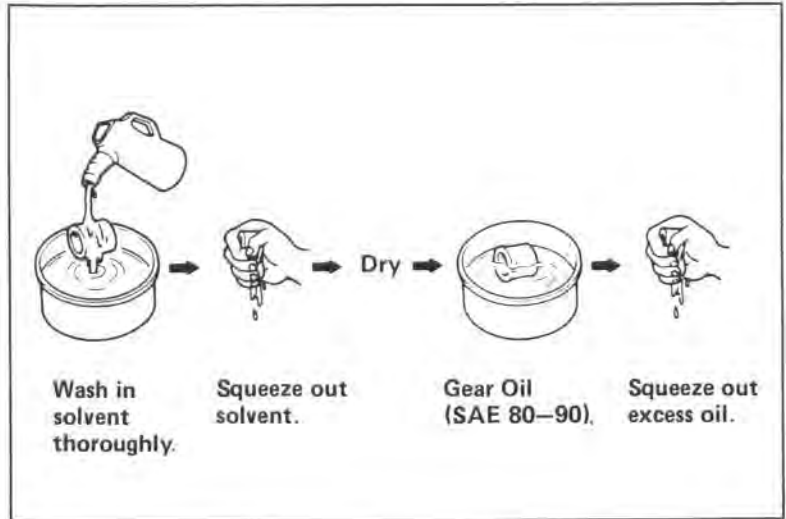

**HIGH ALTITUDE ADJUSTMENT**

The carburetor must be adjusted for high altitude riding (above 2,000 m/6,500 ft).

**STANDARD SETTING:**

2,000 m (6,500 ft) maximum

**HIGH ALTITUDE SETTING:**

1,500 m (5,000 ft) minimum

**ADJUSTMENT**

Remove and disassemble the carburetor and throttle valve (pages 4-6—4-8).

Replace the standard main jet with the high altitude type, and reposition the jet needle clip (see chart). Adjust the pilot screw (see chart).

Reassemble and reinstall the carburetor and throttle valve (page 4-8—4-9).

**CAUTION:** Sustained operation below 1,500 m (5,000 ft) with the high altitude settings may cause engine damage. Install the main jet, return the jet needle clip to the standard position and pilot screw to the factory preset position when riding below 1,500 m (5,000 ft).

	Standard (2,000 m/6,500 ft max)		High altitude (1,500 m/5,000 ft min)	
	ATC185S	ATC200	ATC185S	ATC200
Main Jet	No. 98	No. 95	No. 92	No. 90
Pilot screw opening	1 turn out	1¼ turns out	1 turn out	1½ turns out
Jet needle clip	2nd groove	3rd groove	1st groove	2nd groove

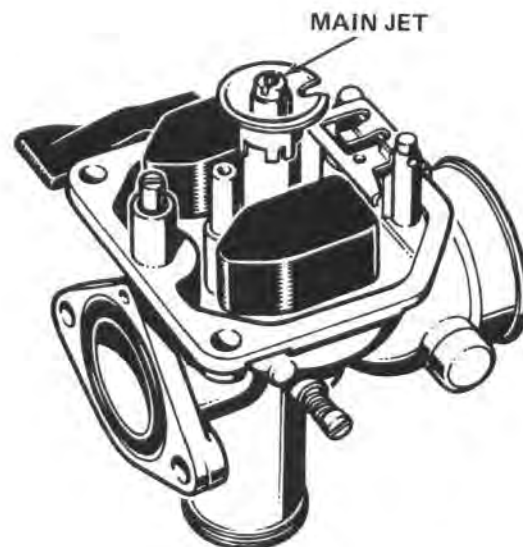



## 4. FRONT WHEEL/ SUSPENSION

### NOTE

An ATC200 with leading axle is shown.  
The ATC185S has a trailing axle.

### FRONT WHEEL

#### REMOVAL

Raise the front wheel off the ground by placing a block or safety stand under the engine.

Disconnect the front brake cable.

Loosen the front axle holder nuts and remove the front axle and collar.

Remove the front wheel.

#### INSTALLATION

Install the axle holder with the UP mark facing up. Do not tighten the axle holder nuts at this time.

Place the front wheel between the front forks, inserting the tab on the brake panel into the hole on the right front fork.

Install the axle collar into the hub and place the front axle through the left front fork, collar, front wheel and front brake panel. Thread the axle into the right fork tube.

Tighten the axle:

**TORQUE: 70–110 N·m (7.0–11.0 kg-m, 51–80 ft-lb)**

Tighten the upper axle holder nuts. Then tighten the lower axle holder nuts.

**TORQUE: 10–14 N·m (1.0–1.4 kg-m, 7–10 ft-lb)**

Install the front brake cable and adjust brake free play (page 3-11).

### FRONT SUSPENSION

#### REMOVAL

Remove the front brake cable from the front brake arm. Loosen the axle holder nuts and remove the axle.

Remove the front wheel.

Remove the upper fork tube pinch bolt and loosen the lower bolt.

Remove the fork tube.

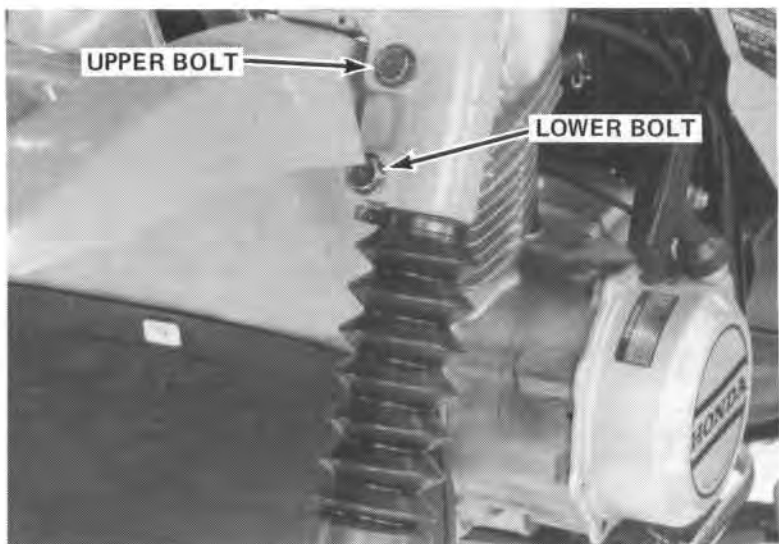
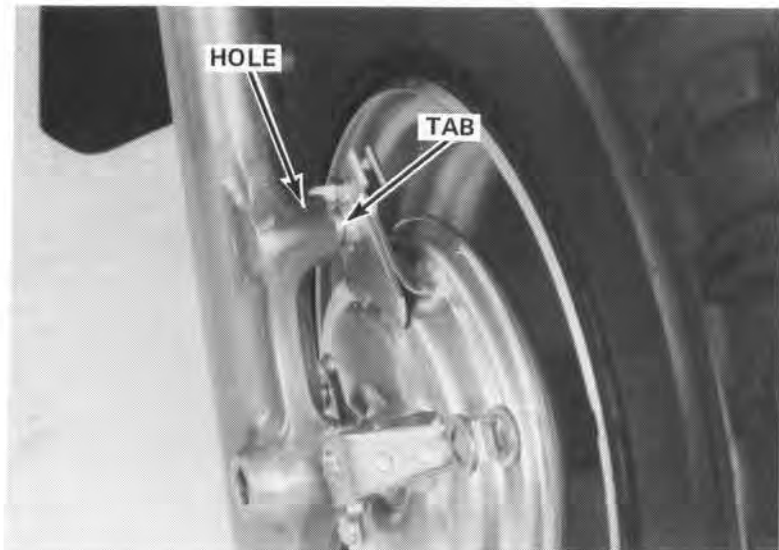
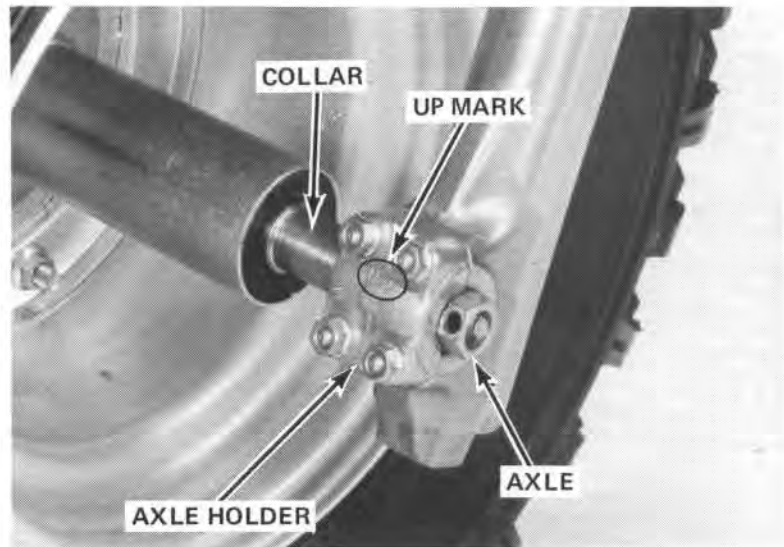



### DISASSEMBLY

Loosen the fork boot band screw.

Remove the boot and dust seal from the slider.

Remove the oil drain plug and drain the fork oil.

Remove the hex bolt from the bottom of the fork tube.

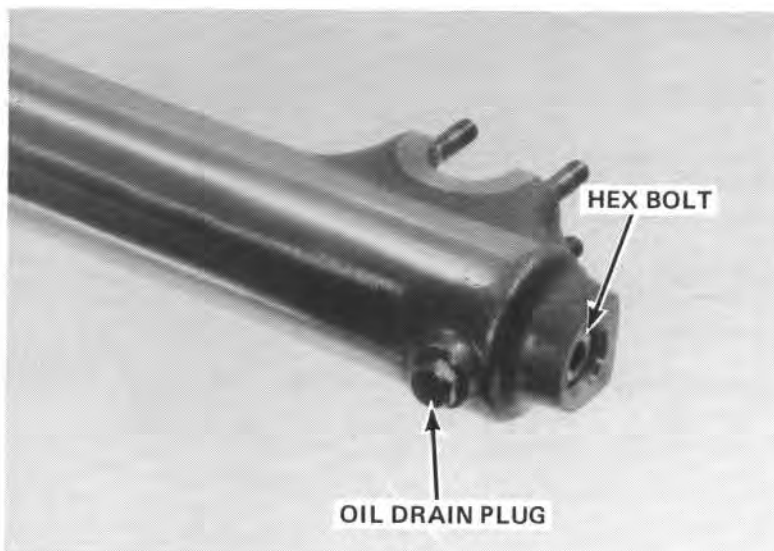

Support the fork tube in a hydraulic press. Compress the fork cap about 20 mm and remove the circlip.

#### NOTE

Use an appropriate cone shaped adapter on the hydraulic press.

#### CAUTION

- Do not compress the fork cap more than necessary to remove the circlip.
- Always wear eye and face protection whenever operating a hydraulic press.



Remove the fork tube from the press.

Remove the spring, oil lock piece, and piston from the fork tube.

Remove the oil seal from the slider.

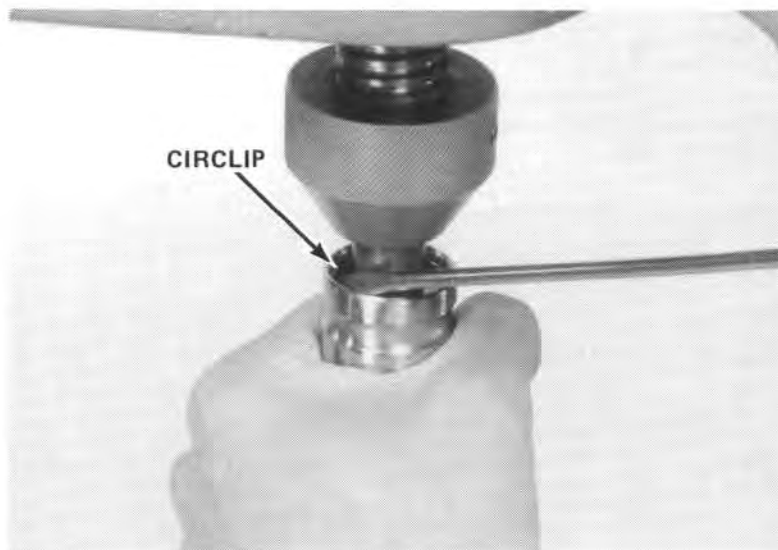



## INSPECTION

### SPRING

Measure the free length of the fork springs. Replace the springs if they are shorter than the service limit.

#### SERVICE LIMIT:

**SPRING A** 228.7 mm (9.0 in)

**SPRING B** 77.6 mm (3.1 in)

#### STANDARD:

**SPRING A** 235.7 mm (9.3 in)

**SPRING B** 79.9 mm (3.1 in)

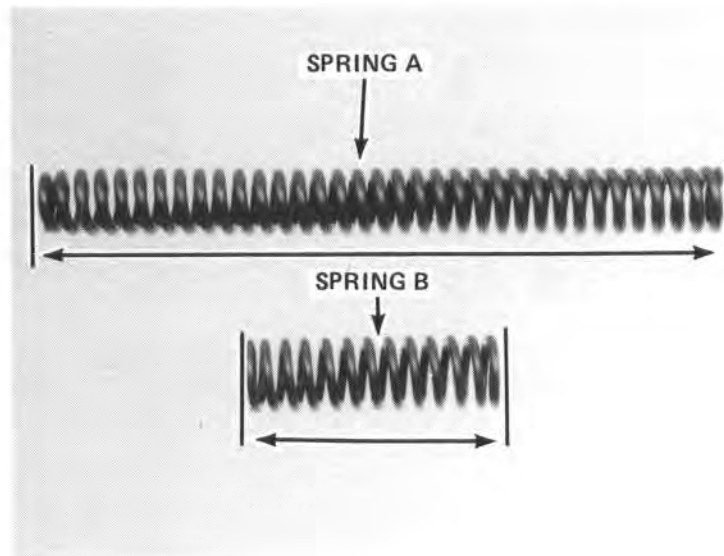

Check the fork tube and piston for score marks, scratches, excessive or abnormal wear. Replace, if necessary.

### ASSEMBLY

Wash all parts in non-flammable solvent and wipe them off thoroughly before assembly.

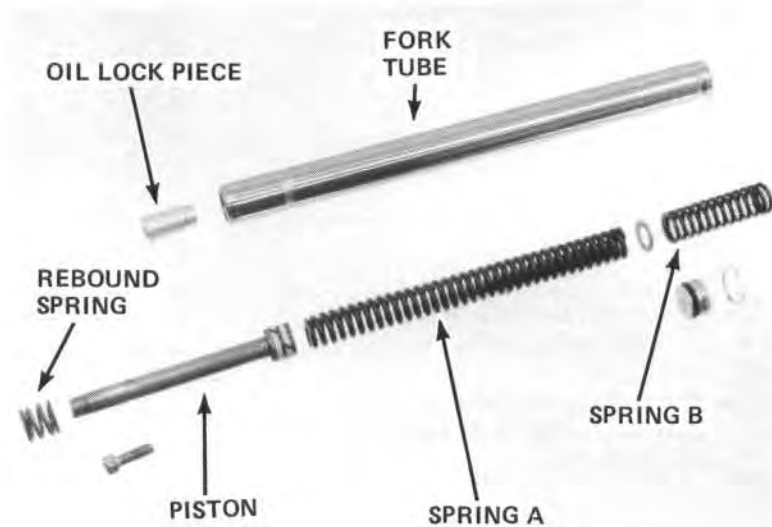

Place the oil lock piece into the fork slider. Place the rebound spring and piston into the fork tube. Place the fork tube into the slider. Clean the hex bolt threads and apply a locking agent to them.

Install and tighten the hex bolt.

**TORQUE: 15—25 N·m (1.5—2.5 kg-m,  
11—18 ft-lb)**

Tighten the oil drain plug securely.

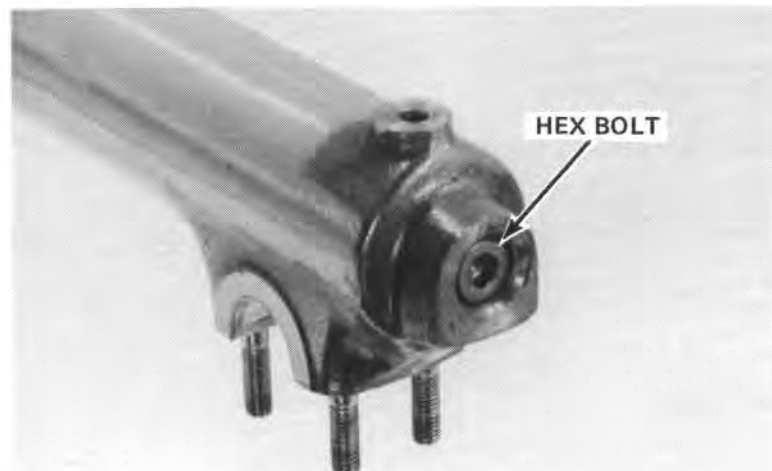



## '83 ADDENDUM



**HONDA**  
**ATC185S-200**

Coat a new oil seal with ATF and install it with the seal markings facing up. Drive the seal in with the seal driver.

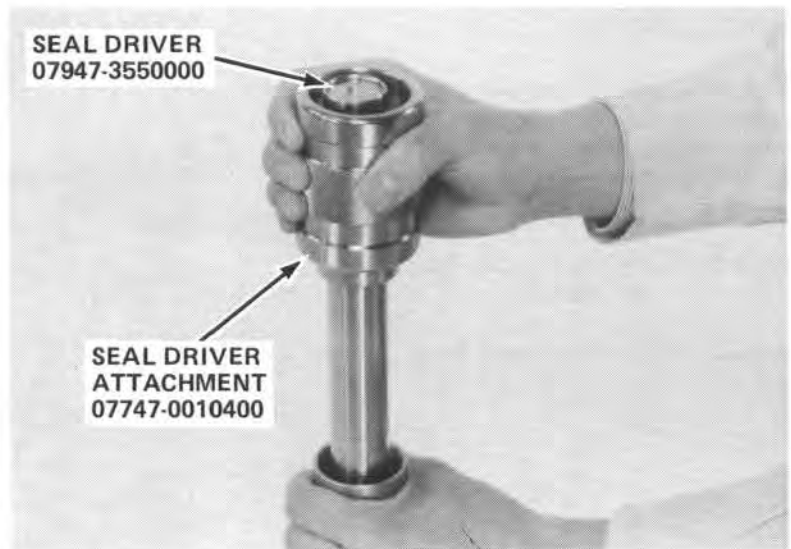

Install the fork seal circlip into the groove in the slider.

Pour ATF into the fork tube.

**OIL CAPACITY: 85—90 cc (3.0 oz)**

Install the fork springs with spacer into the fork tube.

### NOTE

Spring A's tightly wound coils should face up.

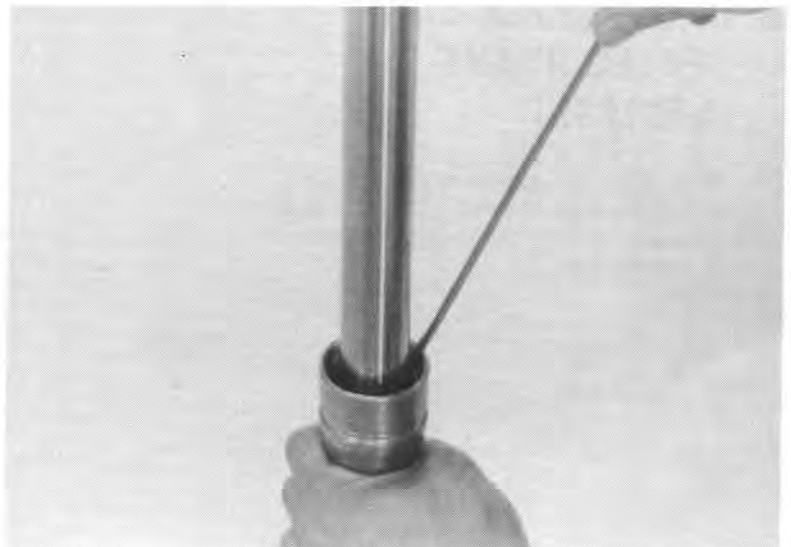

Place the fork cap into place.

Support the fork tube in a hydraulic press.

Compress the cap about 20 mm and install the circlip.

Install the fork tube seal dust cover.

Place the fork tube boot over the fork tube.





## INSTALLATION

Insert the front forks into the steering stem. Install the front fork upper bolt, aligning the groove on the front fork tube with the bolt.

Tighten the bolts to the specified torque.

**TORQUE: 40—50 N·m (4—5 kg-m,  
29—36 ft-lb)**

Install the front wheel (page 21-8).

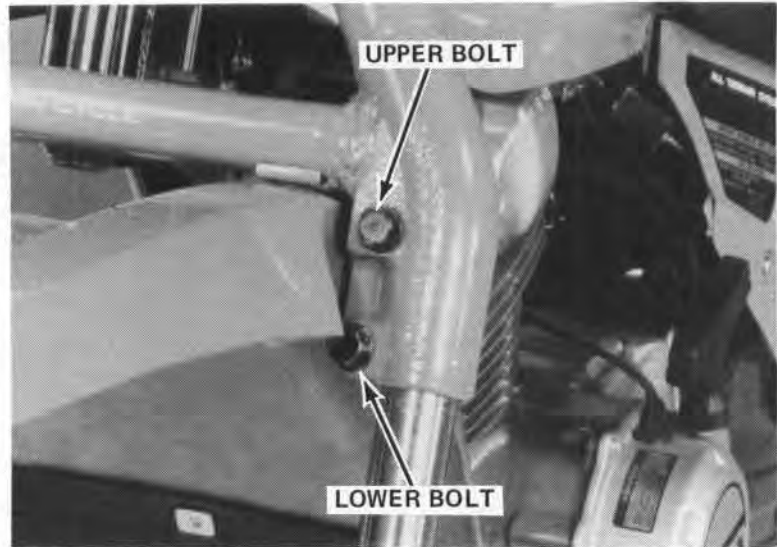

## 5. DRIVE CHAIN AND SEALED BRAKE (ATC185S)

The drive chain and sealed brake are now similar to the type used on the ATC200. Refer to pages 20-11 and 20-15 for servicing information of these parts.



'83 ADDENDUM

**6. WIRING DIAGRAM**

IGNITION SWITCH CONTINUITY

	IG	E
OFF	○	○
RUN		
COLOR	Bl	G

Bl	BLACK	Br	BROWN
Y	YELLOW	O	ORANGE
Bu	BLUE	Lb	LIGHT BLUE
G	GREEN	Lg	LIGHT GREEN
R	RED	P	PINK
W	WHITE	Gr	GRAY

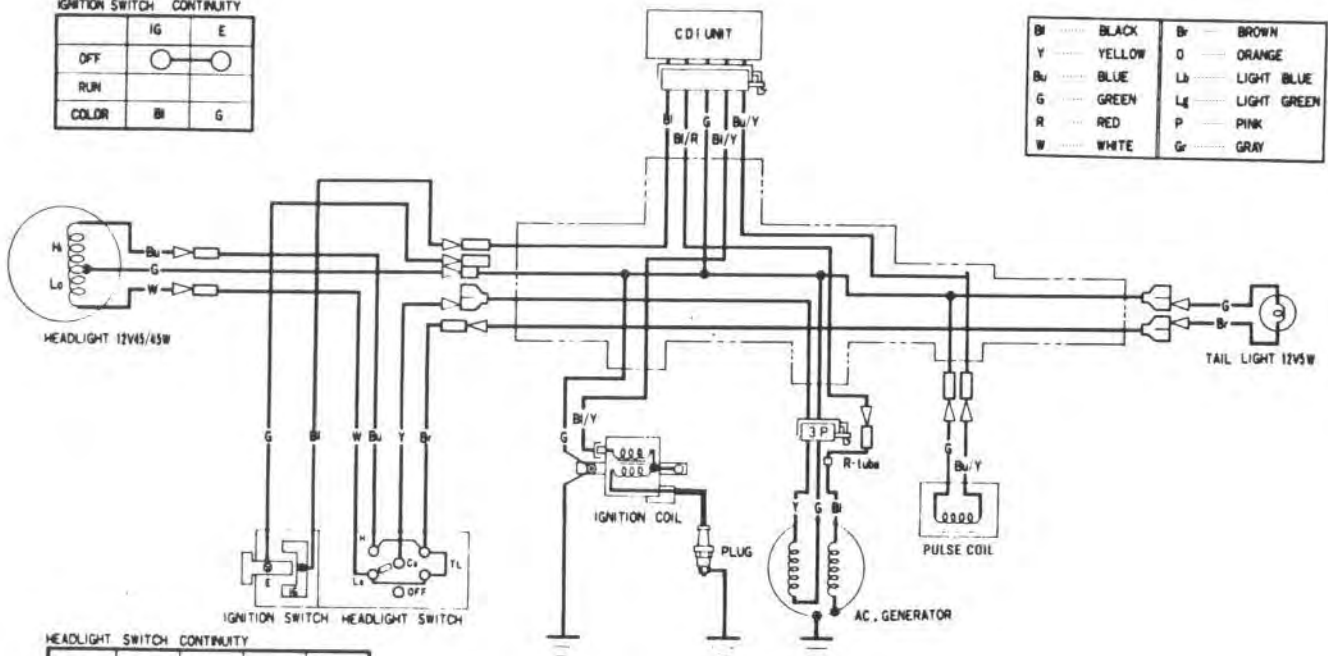

HEADLIGHT SWITCH CONTINUITY

	Lo	Co	TL	H
OFF				
LOW	○	○	○	
HIGH		○	○	○
COLOR	W	Y	Br	Bu



**HONDA**  
**ATC185S-200**

**'83 ADDENDUM**

---