

Official

HONDA

SHOP MANUAL

ATC125M



'84 ~ '85

**WARNING**

Indicates a strong possibility of severe personal injury or loss of life if instructions are not followed.

CAUTION: *Indicates a possibility of personal injury or equipment damage if instructions are not followed.*

NOTE: Gives helpful information.

Detailed descriptions of standard workshop procedures, safety principles and service operations are not included. It is important to note that this manual contains some warnings and cautions against some specific service methods which could cause **PERSONAL INJURY** to service personnel or could damage a vehicle or render it unsafe. Please understand that those warnings could not cover all conceivable ways in which service, whether or not recommended by Honda might be done or of the possible hazardous consequences of each conceivable way, nor could Honda investigate all such ways. Anyone using service procedures or tools, whether or not recommended by Honda *must satisfy himself thoroughly* that neither personal safety nor vehicle safety will be jeopardized by the service methods or tools selected.

HOW TO USE THIS MANUAL

Sections 1 through 3 apply to the whole ATC, while sections 4 through 18 describe parts of the ATC, grouped according to location.

Find the section you want on this page, then turn to the table of contents on page 1 of that section.

Most sections start with an assembly or system illustration and all the required specifications, torque values, general instructions, tools and troubleshooting for the section. The subsequent pages give detailed procedures.

If you don't know the source of the trouble, see section 19, TROUBLESHOOTING.

CONTENTS

	GENERAL INFORMATION	1
	LUBRICATION	2
	MAINTENANCE	3
ENGINE	FUEL SYSTEM	4
	ENGINE REMOVAL/INSTALLATION	5
	CYLINDER HEAD/VALVES	6
	CYLINDER/PISTON	7
	CLUTCH/OIL PUMP	8
	RECOIL STARTER/ALTERNATOR/ CAM CHAIN TENSIONER	9
	SUB-TRANSMISSION	10
	TRANSMISSION/CRANKSHAFT	11
CHASSIS	FRONT WHEEL/BRAKE/ STEERING	12
	REAR WHEEL/BRAKE/DRIVE MECHANISM	13
	REAR FENDER/EXHAUST PIPE	14
ELECTRICAL	IGNITION SYSTEM	15
	BATTERY/CHARGING SYSTEM	16
	STARTER SYSTEM	17
	LIGHTS/SWITCHES	18
	TROUBLESHOOTING	19

CONTENTS

HOW TO USE THIS MANUAL

... apply to the model ...
... the ATC ...

... you want on the ...
... the table ...

... the assembly ...
... of the ...
... the ...
... the ...

... know the ...
... THE ...

... the ...
... the ...
... the ...
... the ...

... of ...
... of ...

SEARCH ...

LUBRICATION

MAINTENANCE

FUEL SYSTEM

IN-TIME REMOVAL/INSTALLATION

CYLINDER HEAD VALVES

VALVE ADJUSTMENT

CRANKSHAFT

PISTON STARTER & TENSIONER
BELT CHAIN TENSIONER

TRANSMISSION

TRANSMISSION CRANKSHAFT

FRONT WHEEL BRAKE
STEERING

FRONT WHEEL DRIVE
STEERING

REAR WHEEL DRIVE

IGNITION SYSTEM

BAT. CHARGING SYSTEM

STARTER SYSTEM

LIGHT SWITCHES

TRUBLESHOOTING

ENGINE

DRIVING

ELECTRICAL

1. GENERAL INFORMATION

GENERAL SAFETY	1-1
SERVICE RULES	1-1
MODEL IDENTIFICATION	1-2
SPECIFICATIONS	1-3
TORQUE VALUES	1-5
TOOLS	1-6
CABLE & HARNESS ROUTING	1-7
NOISE EMISSION CONTROL SYSTEM	1-12

GENERAL SAFETY

WARNING

If the engine must be running to do some work, make sure the area is well-ventilated. Never run the engine in a closed area. The exhaust contains poisonous carbon monoxide gas.

WARNING

The battery electrolyte contains sulfuric acid. Protect your eyes, skin and clothing. If electrolyte gets in your eyes, flush them thoroughly with water and call a doctor.

WARNING

Gasoline is extremely flammable and is explosive under certain conditions. Do not smoke or allow flames or sparks in your work area.

WARNING

The battery generates hydrogen gas which can be highly explosive. Do not smoke or allow flames or sparks near the battery, especially while charging it.

SERVICE RULES

1. Use genuine HONDA or HONDA-recommended parts and lubricants or their equivalent. Parts that don't meet HONDA's design specifications may damage the ATC.
2. Use the special tools designed for this product to avoid damage and incorrect assembly.
3. Use only metric tools when servicing this ATC. Metric bolts, nuts, and screws are not interchangeable with English fasteners.
4. Install new gaskets, O-rings, cotter pins, and lock plates when reassembling.
5. When tightening bolts or nuts, begin with the larger-diameter or inner bolt first. Then tighten to the specified torque diagonally in 2-3 steps, unless a particular sequence is specified.
6. Clean parts in non-flammable or high flash point solvent upon disassembly.
7. Lubricate any sliding surfaces before reassembly.
8. After reassembly, check all parts for proper installation and operation.

MODEL IDENTIFICATION



The frame serial number is stamped on the steering head left side.

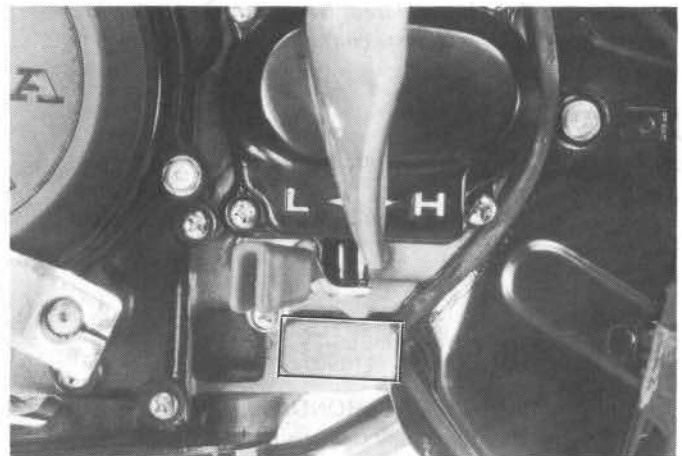

The engine serial number is stamped on the crankcase lower left side.

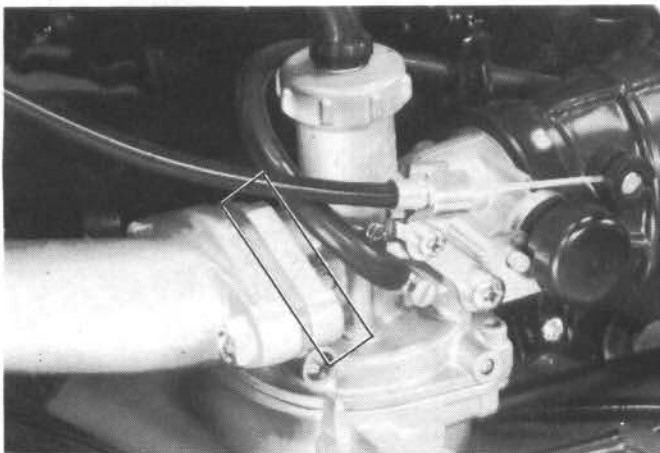

The carburetor identification number is on the carburetor body left side.

SPECIFICATIONS

ITEM		
DIMENSIONS	Overall length	1,675 mm (65.9 in)
	Overall width	980 mm (38.5 in)
	Overall height	950 mm (37.4 in)
	Wheelbase	1,075 mm (42.3 in)
	Rear tread	710 mm (28.0 in)
	Seat height	645 mm (25.4 in)
	Foot peg height	260 mm (10.2 in)
	Ground clearance	115 mm (4.5 in)
	Dry weight	126 kg (278 lb)
FRAME	Type	Backbone (Pressed)
	Rim size	6.5 spw x 7DT
	Front	6.5 spw x 7DT
	Rear	6.5 spw x 7DT
	Front tire size, pressure	22 x 11.0-8, 0.15 kg/cm ² (2.2 psi)
	Rear tire size, pressure	22 x 11.0-8, 0.15 kg/cm ² (2.2 psi)
	Front brake	Internal expanding shoe
	Rear brake	Internal expanding shoe
	Fuel capacity	7.7 liters (2.0 US gal, 1.70 Imp gal)
Fuel reserve capacity	0.5 liters (0.13 US gal, 0.11 Imp gal)	
Caster angle	71°	
Trail length	14 mm (0.5 in)	
ENGINE	Type	Gasoline, air-cooled 4-stroke
	Cylinder arrangement	Single cylinder, 75° inclined from vertical
	Bore x stroke	55 x 52.2 mm (2.16 x 2.05 in)
	Displacement	124 cc (7.6 cu in)
	Compression ratio	8.8 : 1
	Valve train	Overhead camshaft chain driven
	Maximum horse power	8.6 BHP/7,500 rpm
	Maximum torque	0.89 kg-m/5,500 rpm (6.45 ft-lb/5,500 rpm)
	Oil capacity	1.1 liters (1.16 US qt, 0.97 Imp qt) at draining
	Lubrication system	Forced pressure and wet sump
	Cylinder compression	12.5 ± 1.5 kg/cm ² (177.8 ± 21.3 psi)
	Intake valve	OPENS 5° BTDC
		CLOSES 20° ABDC
	Exhaust valve	OPENS 25° BBDC
		CLOSES 5° ATDC
Valve clearance	Intake	
(Cold)	Exhaust	
Idle speed	0.07 mm (0.003 in) 0.07 mm (0.003 in) 1,700 rpm	
CARBURETOR	Type	Piston valve
	Main jet No.	#92
	Slow jet No.	#38
	Pilot screw opening	1-3/8 turns out
	Float level	10.7 mm (0.43 in)

GENERAL INFORMATION

<p>DRIVE TRAIN</p>	<p>Clutch Transmission Primary reduction Gear ratio</p> <p>1st 2nd 3rd 4th</p> <p>Final reduction Gearshift pattern</p>	<p>Wet multi-plate automatic 4-speed constant-mesh 3.722</p> <table border="0"> <tr> <td>High</td> <td>Low</td> </tr> <tr> <td>2.462</td> <td>3.794</td> </tr> <tr> <td>1.556</td> <td>2.398</td> </tr> <tr> <td>1.190</td> <td>1.834</td> </tr> <tr> <td>0.958</td> <td>1.476</td> </tr> </table> <p>3.500, Drive sprocket 14T, driven sprocket 49T Left foot operated return system N-1-2-3-4</p>	High	Low	2.462	3.794	1.556	2.398	1.190	1.834	0.958	1.476
High	Low											
2.462	3.794											
1.556	2.398											
1.190	1.834											
0.958	1.476											
<p>ELECTRICAL</p>	<p>Ignition Ignition timing Initial Full advance</p> <p>Battery Alternator capacity '84 After '84</p> <p>Spark plug</p> <p>Spark plug gap Headlight Taillight Starter motor</p>	<p>CDI 10° BTDC at idle 32° BTDC at 3,400 rpm 12V 9AH (YB9A-A) 12V 48 w/6,000 rpm 14V 70 w/5,000 rpm DR8ES-L (NGK) RA6YC (CHAMPION) X24ESR-U (ND) 0.6-0.7 mm (0.024-0.028 in) 12V 45W/45W 1.2V 5W 12V 450W</p>										

TORQUE VALUES**ENGINE**

Item	Q'ty	Thread dia. (mm)	N·m	kg-m	ft-lb
Cylinder head nut	4	8	18-20	1.8-2.0	13-14
Camshaft sprocket bolt	2	6	8-12	0.8-1.2	6-9
Cam chain guide roller bolt	1	6	9-14	0.9-1.4	7-10
Spark advancer bolt	1	6	8-12	0.8-1.2	6-9
Clutch lock nut	1	16	40-50	4.0-5.0	29-36
Alternator rotor bolt	1	8	40-45	4.0-4.5	29-33
Shift drum bolt	1	6	18-22	1.8-2.2	13-16

FRAME

Item	Q'ty	Thread dia. (mm)	N·m	kg-m	ft-lb
Steering stem nut	1	22	50-70	5.0-7.0	36-51
Fork bridge bolt	2	12	50-70	5.0-7.0	36-51
Handlebar upper holder bolt	4	8	18-30	1.8-3.0	13-22
Handlebar lower holder nut	2	10	40-48	4.0-4.8	29-35
Front axle nut	2	12	50-70	5.0-7.0	36-51
Brake drum nut					
Inner	1	32	35-45	3.5-4.5	25-33
Outer	1	32	120-140	12.0-14.0	87-101
Seat and rear fender	10	6	6-9	0.6-0.9	4.5-7
Engine hanger bolt					
Front	3	8	19-25	1.9-2.5	14-18
Rear	2	10	30-40	3.0-4.0	22-29
Intake pipe and carburetor	2	6	6-9	0.6-0.9	4.5-7
Final driven sprocket nut	4	8	21-27	2.1-2.7	15-20
Gearshift pedal bolt	1	6	7-12	0.7-1.2	5-9
Fender and mud guard	11	4	5-7	0.5-0.7	3.6-5
Rear axle nut	2	14	60-80	6.0-8.0	43-58
Foot peg bolt	4	8	19-25	1.9-2.5	14-18
Bearing holder bolt	4	12	50-70	5.0-7.0	36-51

Torque specifications listed above are for the most important tightening points. If a torque specification is not listed, use the standards given below.

STANDARD TORQUE VALUES

Item	TORQUE N·m (kg-m, ft-lb)	Item	TORQUE N·m (kg-m, ft-lb)
5 mm bolt, nut	4.5-6 (0.45-0.6, 3.5-4.5)	5 mm screw	3.5-5 (0.35-0.5, 2.5-3.6)
6 mm bolt, nut	8-12 (0.8-1.2, 6-9)	6 mm screw (6 mm flange bolt with 8 mm head)	7-11 (0.7-1.1, 5-8)
8 mm bolt, nut	18-25 (1.8-2.5, 13-18)	6 mm flange bolt, nut	10-14 (1.0-1.4, 7-10)
10 mm bolt, nut	30-40 (3.0-4.0, 22-29)	8 mm flange bolt, nut	24-30 (2.4-3.0, 17-22)
12 mm bolt, nut	50-60 (5.0-6.0, 36-43)	10 mm flange bolt, nut	30-40 (3.0-4.0, 22-29)

GENERAL INFORMATION

TOOLS

SPECIAL

Description	Number	Alternative	Ref. Page
Bearing remover set, 12 mm (Bearing assembly, 12 mm) (Remover weight)	07936-1660001 (07936-1660100) (07741-0010201)	07936-3710200	10-5
Bearing remover set, 15 mm	07936-KC10000		10-4
Valve guide reamer	07984-0980000		6-10
Ball race remover	07944-1150001	M9360-91774 (Available in USA only)	12-19
Axle nut torque wrench adapter	07916-958010A	(USA only)	13-5, 13-10
Axle nut holder wrench	07916-958020A	(USA only)	13-5, 13-10
Valve guide driver	07942-1180100		6-10
Valve adjuster	07908-KE90000	89201-200-000 (U.S.A. only)	3-6
Universal bead breaker	GN-AH-958-BB1	Available in U.S.A. only	12-8
Clutch center holder	07923-0340000	Flywheel holder 07725-0040000 or Band strap wrench commercially available in U.S.A.	8-5, 8-11

COMMON

Description	Number	Alternative	Ref. Page
Float level gauge	07401-0010000		4-10
Lock nut wrench, 26 x 30 mm	07716-0020203		12-19, 12-21
Lock nut wrench, 20 x 24 mm	07716-0020100	07916-3710000 or 07916-6390001	8-5, 8-11
Lock nut wrench, 30 x 32 mm	07716-0020400	} Commercially available in U.S.A.	12-18, 12-21
Extension bar	07716-0020500		8-5, 8-11, 12-18, 12-21
Steering stem driver	07946-GC40000		12-20
Flywheel puller	07733-0010000	07933-2000000	9-8
Valve guide remover, 5.5 mm	07742-0010100	07942-3290100	6-10
Valve spring compressor	07757-0010000	07957-3290001	6-8, 6-14
Valve adjusting wrench, 8 x 9 mm	07708-0030100	Commercially available in U.S.A.	3-6
Attachment, 37 x 40 mm	07746-0010200		12-20
Pilot, 35 mm	07746-0040800		13-17
Attachment, 62 x 68 mm	07746-0010500	07947-6340400 } 07946-3600000 or 07946-9180100	13-17
TIRE BRAKER SET	07772-0050000		12-10
Driver	07749-0010000	07949-6110000	10-5, 11-8, 12-12, 13-17
Attachment, 42 x 47 mm	07746-0010300		11-8, 12-12
Pilot, 20 mm	07746-0040500		11-8
Pilot, 15 mm	07746-0040300		10-4, 12-12
Attachment, 32 x 35 mm	07746-0010100		10-4, 10-5
Pilot, 12 mm	07746-0040200		10-5
Flywheel holder	07725-0040000	Band Strap wrench commercially available in U.S.A.	8-5, 8-11, 9-8

CABLE & HARNESS ROUTING

Note the following when routing cables and wire harnesses:

- A loose wire, harness or cable can be a safety hazard. After clamping, check each wire to be sure it is secure.
- Do not squeeze wires against a weld or the end of its clamp.
- Secure wires and wire harnesses to the frame with their respective wire bands at the designated locations. Tighten the bands so that only the insulated surfaces contact the wires or wire harnesses.
- Route harnesses so they are not pulled taut or have excessive slack.
- Protect wires and harnesses with electrical tape or tubes if they are contact a sharp edge or corner. Clean the attaching surface thoroughly before applying tape.
- Do not use a wire or harness with a broken insulator. Repair by wrapping them with protective tape or replace them.
- Route wire harnesses to avoid sharp edges or corners.
- Also avoid the projected ends of bolts and screws.
- Keep wire harnesses away from the exhaust pipes and other hot parts.
- Be sure grommets are seated in their grooves properly.
- After clamping, check each harness to be certain that it is not interfering with any moving or sliding parts.
- Wire harnesses routed along the handlebars should not be pulled taut, have excessive slack, be pinched, or interfere with adjacent or surrounding parts in all steering positions.
- After routing, check that the wire harnesses are not twisted or kinked.

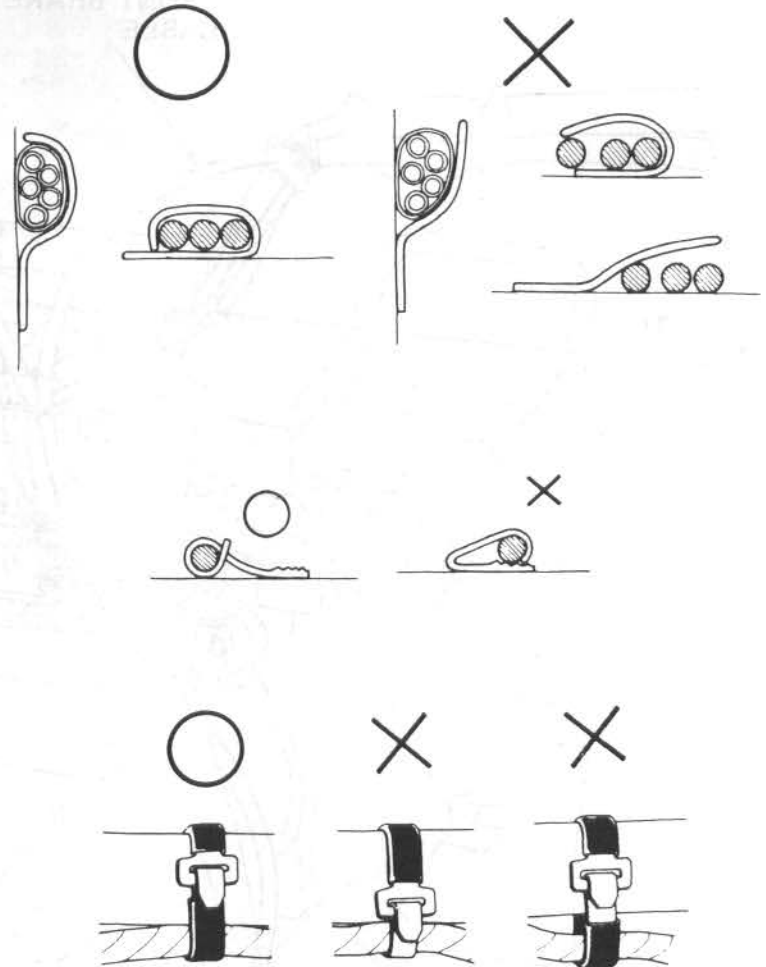

GENERAL INFORMATION

84:

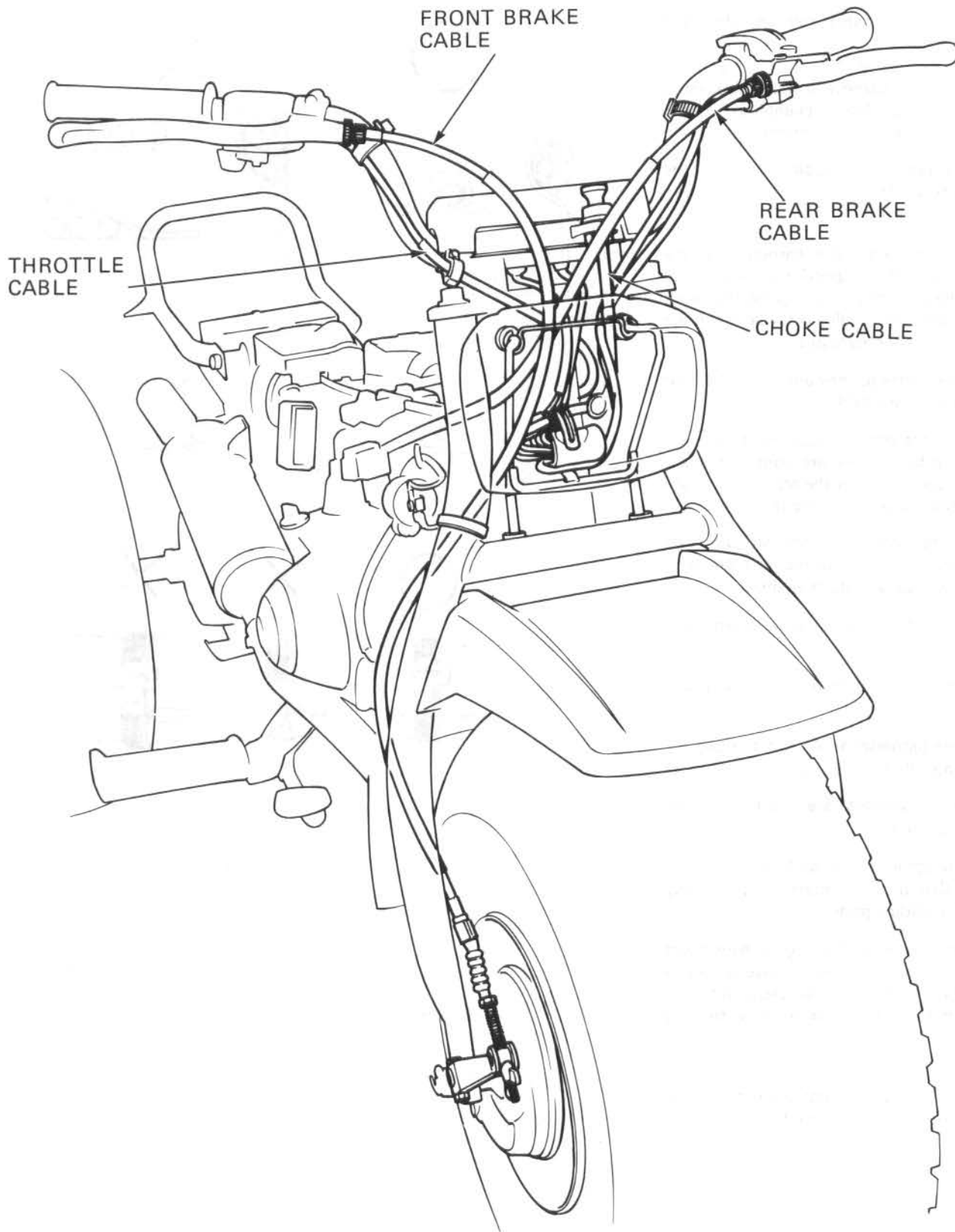

After '84:

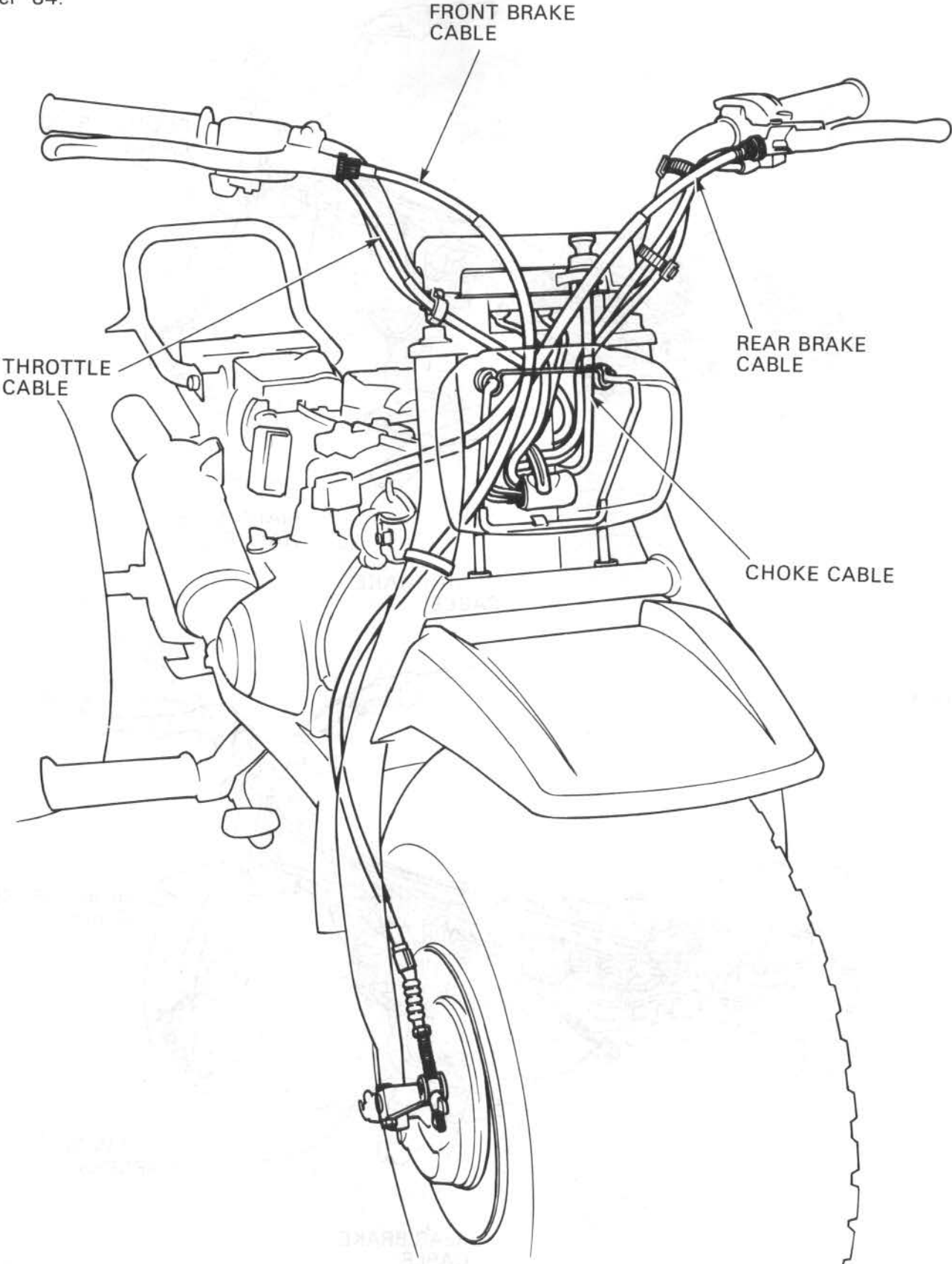

GENERAL INFORMATION

84:

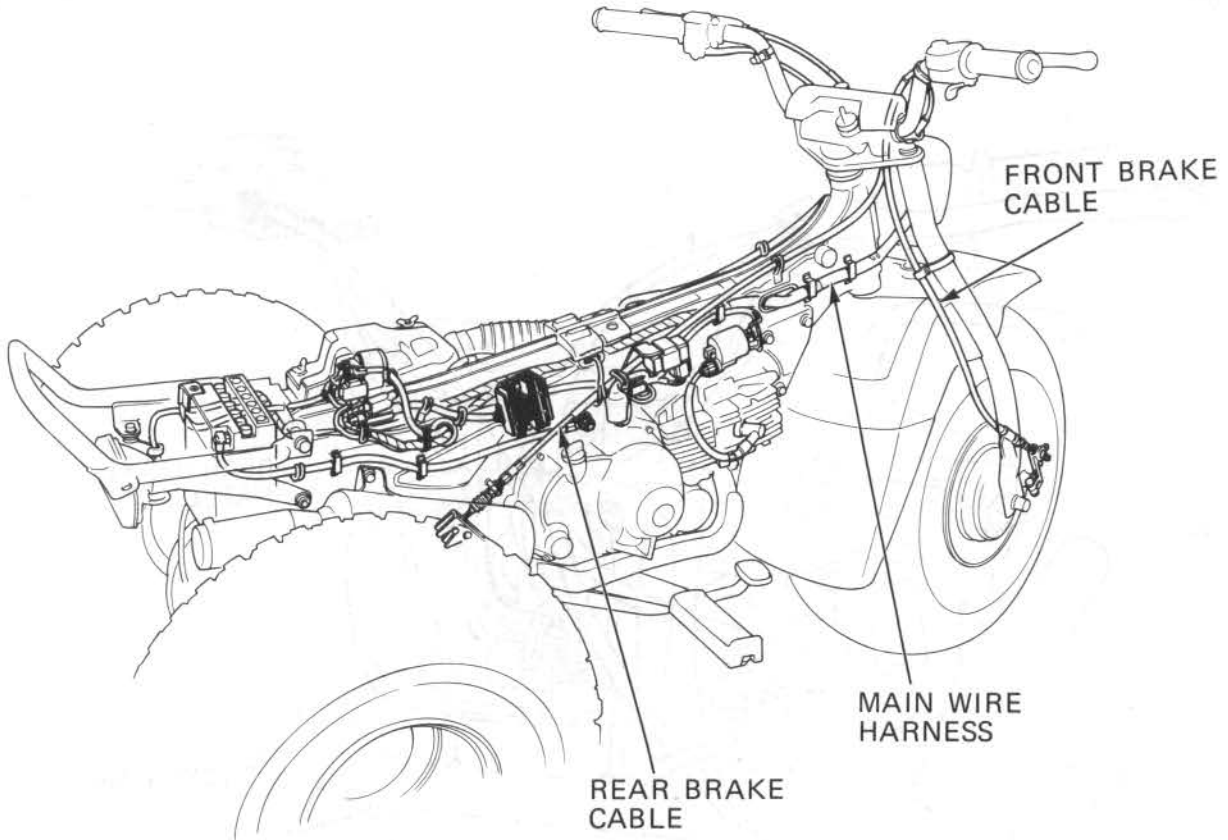

After '84:

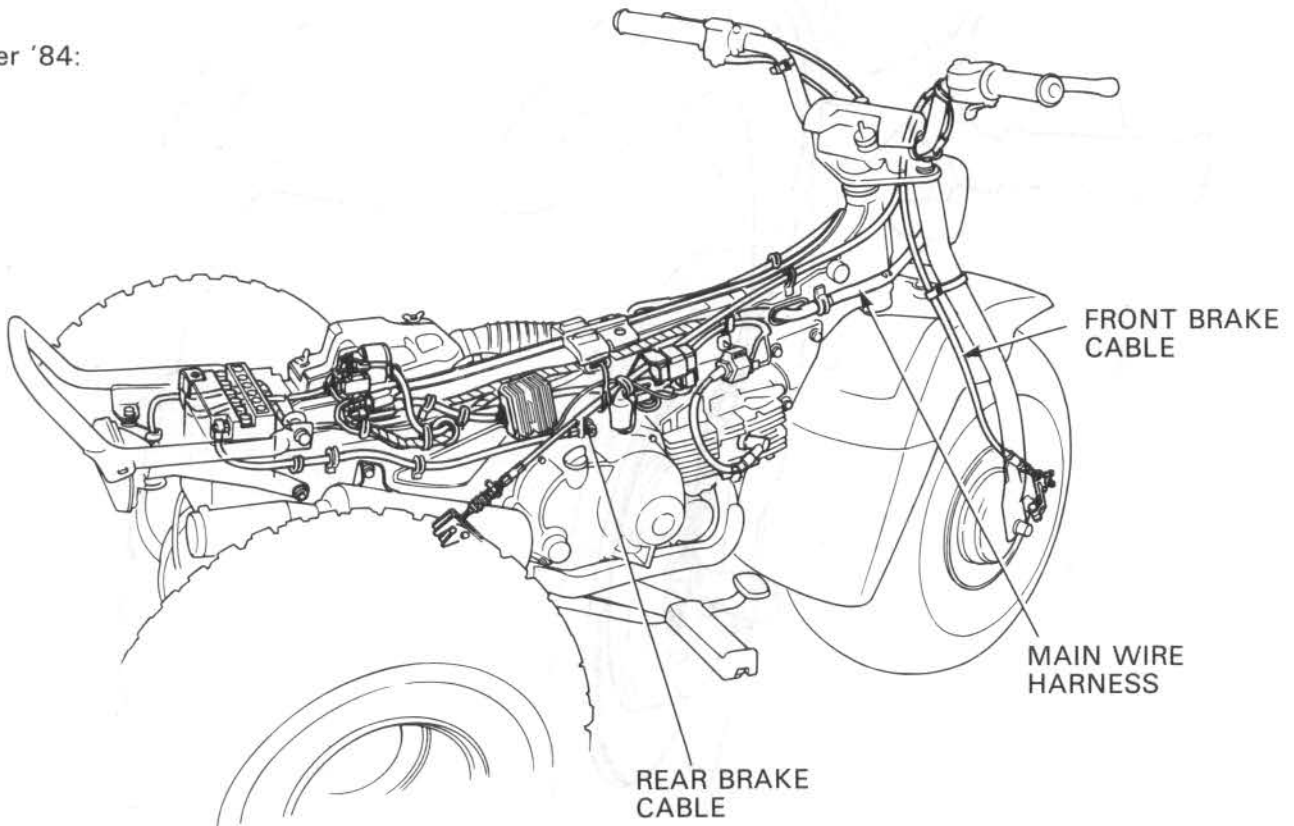

'84:

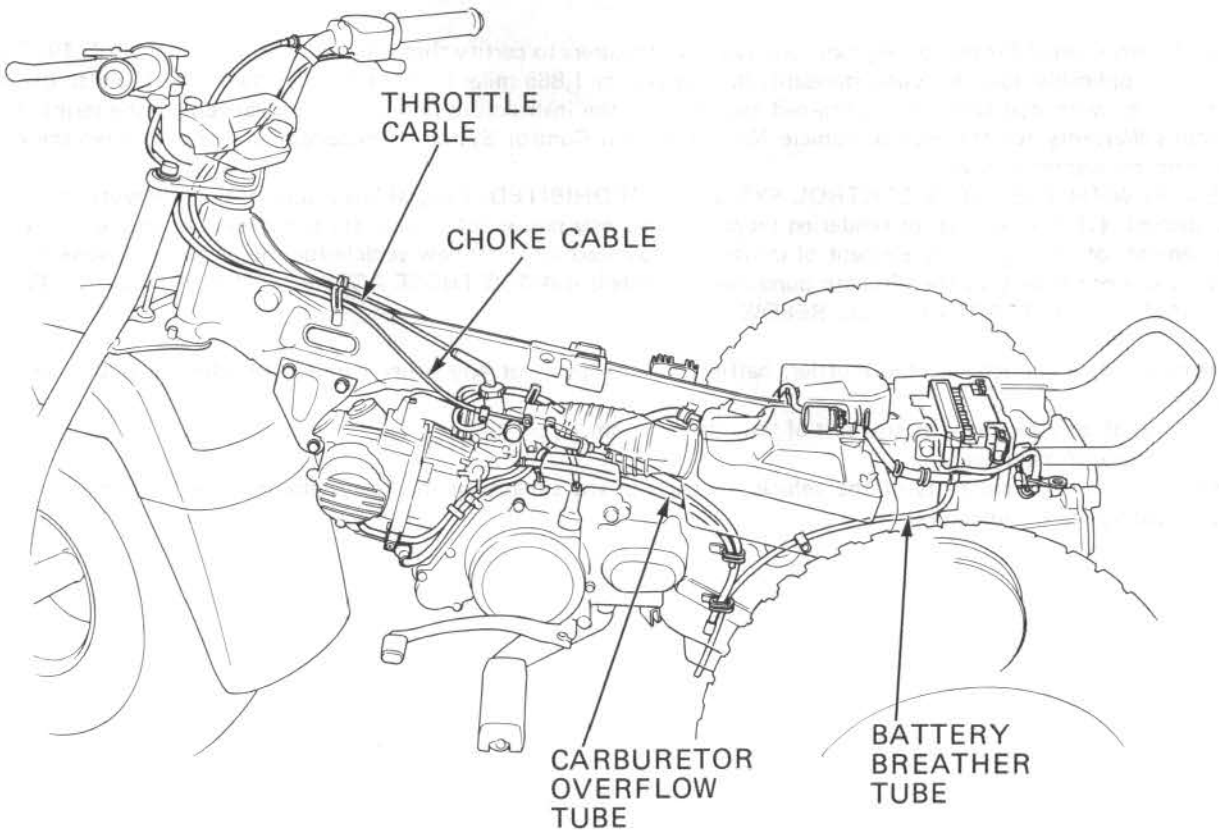

After '84:

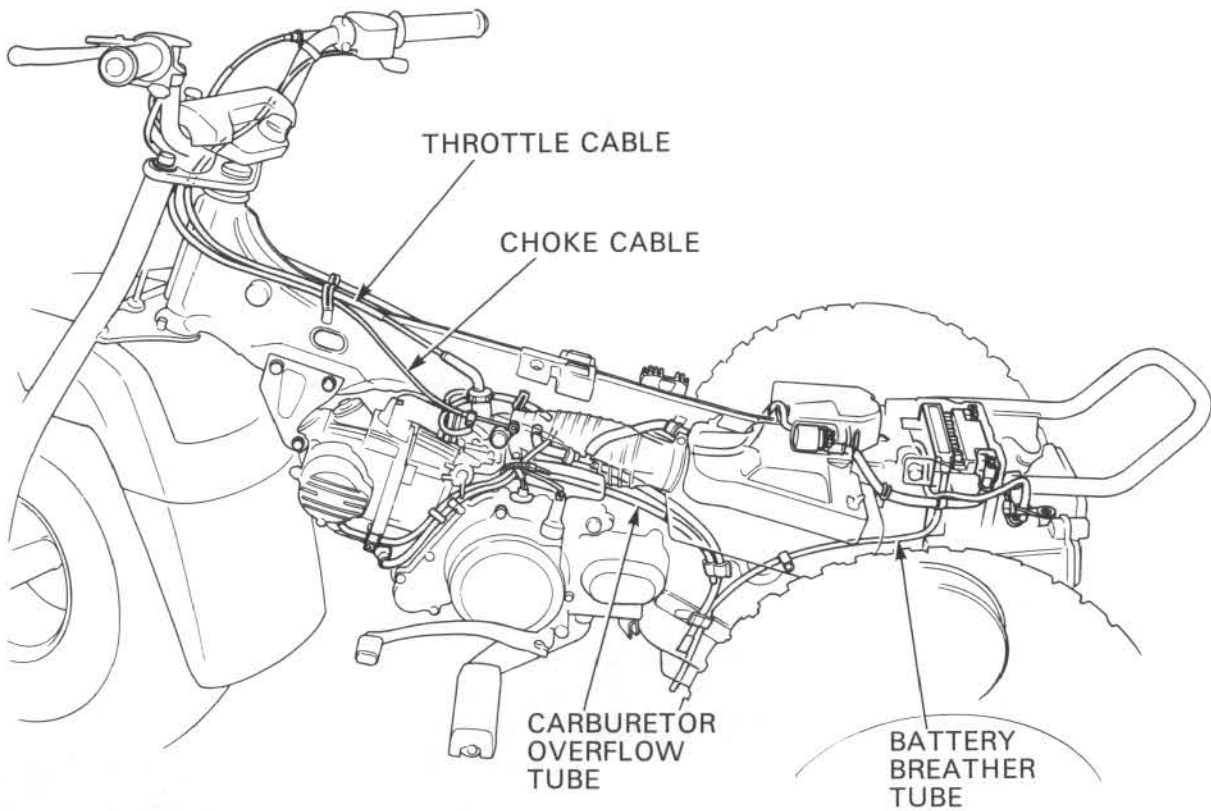

NOISE EMISSION CONTROL SYSTEM

- The U.S. Environmental Protection Agency requires manufacturers to certify that vehicles built after January 1, 1983 will comply with applicable noise emission standards for one year or 1,865 miles (3,000 km) after the time of sale to the ultimate purchaser, when operated and maintained according to the instructions provided. Compliance with the terms of the Distributor's Warranty for the Honda Vehicle Noise Emission Control System is necessary in order to keep the noise emission control system in effect.

TAMPERING WITH THE NOISE CONTROL SYSTEM IS PROHIBITED: Federal law prohibits the following acts or the causing thereof: (1) The removal or rendering inoperative by any person, other than for purposes of maintenance, repair, or replacement, of any device or element of design incorporated into any new vehicle for the purpose of noise control prior to its sale or delivery to the ultimate purchaser or while it is AMOG THOSE ACTS PRESUMED TO CONSTITUTE TAMPERING ARE THE ACTS LISTED BELOW:

1. Removal of, or puncturing the muffler, bafflers, header pipes or any other component which conducts exhaust gases.
2. Removal of, or puncturing of any part of the intake system.
3. Lack of proper maintenance.
4. Replacing any moving parts of the vehicle, or parts of the exhaust or intake system, with parts other than those specified by the manufacturer.

MEMO



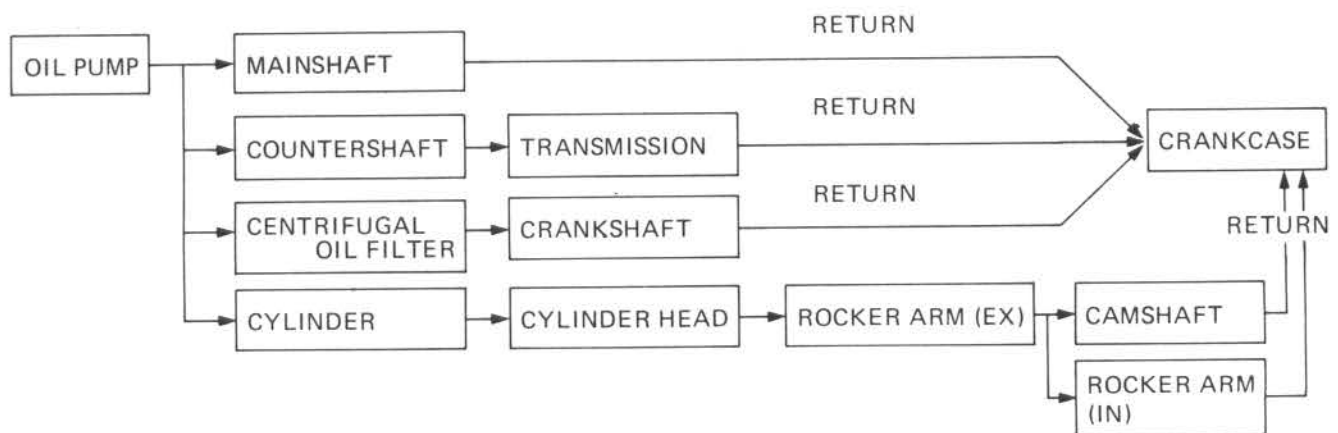
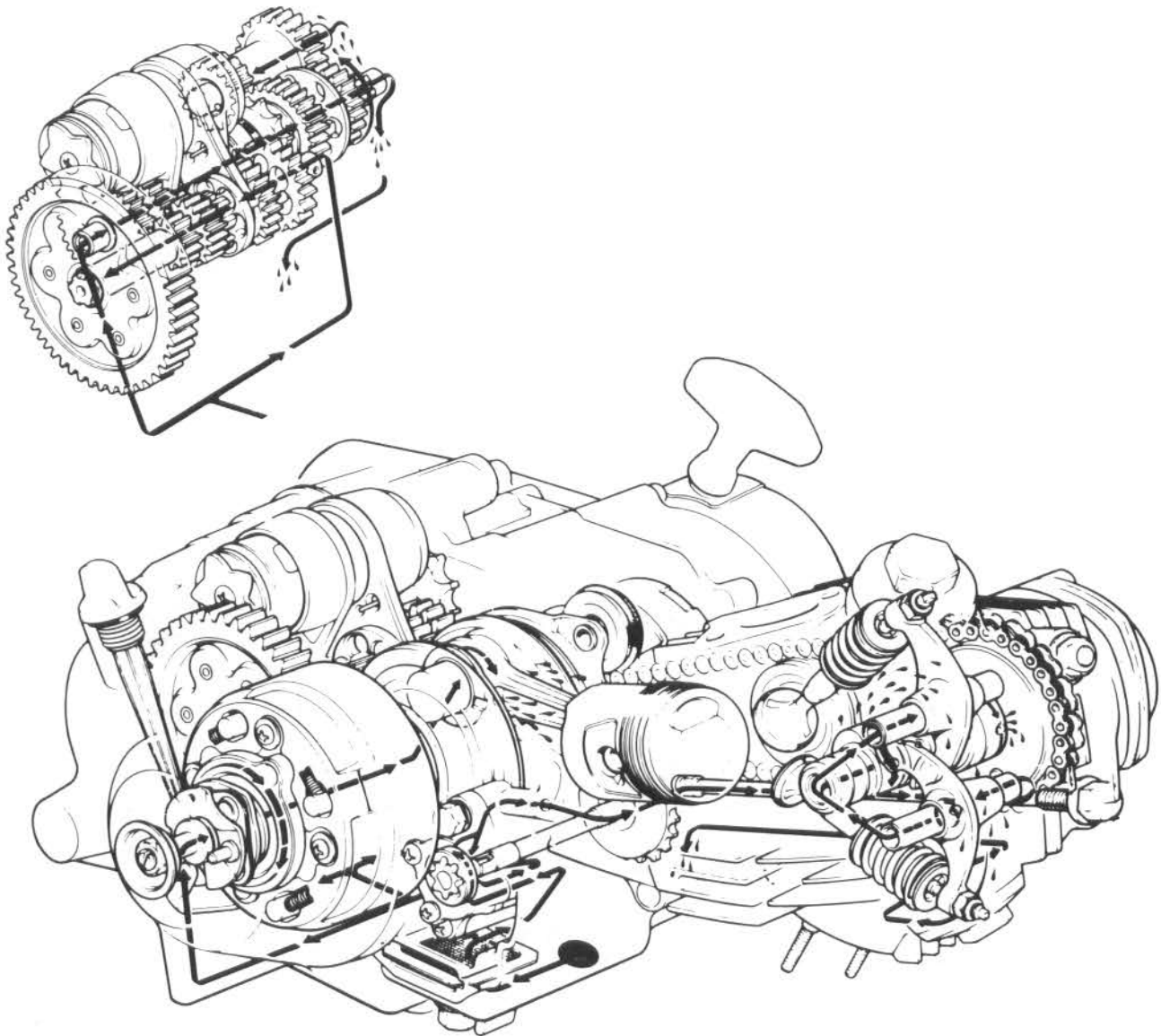

2. LUBRICATION

SERVICE INFORMATION	2-1
TROUBLESHOOTING	2-1
ENGINE OIL LEVEL CHECK	2-2
ENGINE OIL CHANGE	2-2
OIL FILTER ROTOR AND SCREEN	2-3
LUBRICATION POINTS	2-4

SERVICE INFORMATION

GENERAL

- This section describes how to inspect and replace the engine oil and clean the oil filter screen.
- Section 8 shows how to service the oil pump.

SPECIFICATIONS

Oil capacity 1.2 lit (1.27 US qt, 1.06 Imp qt) at disassembly
1.1 lit (1.16 US qt, 0.97 Imp qt) at draining

Engine oil recommendation

Use Honda 4-Stroke Oil or equivalent.
API Service Classification: SE or SF
Viscosity: SAE 10W-40

OIL VISCOSITY CHART

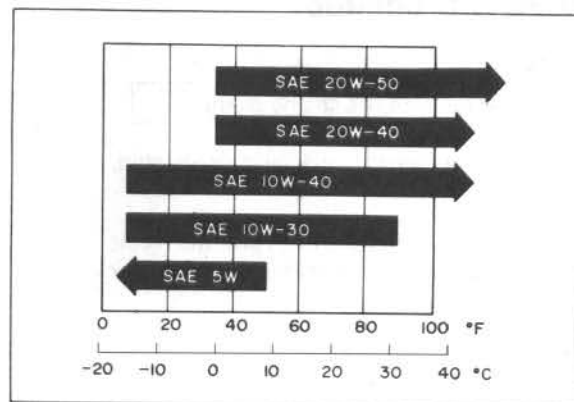

TROUBLESHOOTING

Oil level too low

1. Normal oil consumption
2. External oil leaks
3. Worn piston rings

Oil consumption

1. Oil not changed often enough
2. Faulty head gasket

ENGINE OIL LEVEL CHECK

Place the ATC on level ground.

Start the engine and let it idle for 2–3 minutes.

Check the oil with the oil cap/dipstick.

Do not screw in the cap when making this check.

If the level is below the lower level mark on the dipstick, fill to the upper level mark with the recommended oil (Page 2–1).



ENGINE OIL CHANGE

NOTE

Drain the oil with the engine warm.

Remove the oil cap/dipstick and drain plug, and drain the oil.

With the engine switch "OFF", pull the recoil starter several times to completely drain any residual oil.

Install the drain plug.

NOTE

Check the condition of the sealing washer. If it is damaged, replace it with a new one.

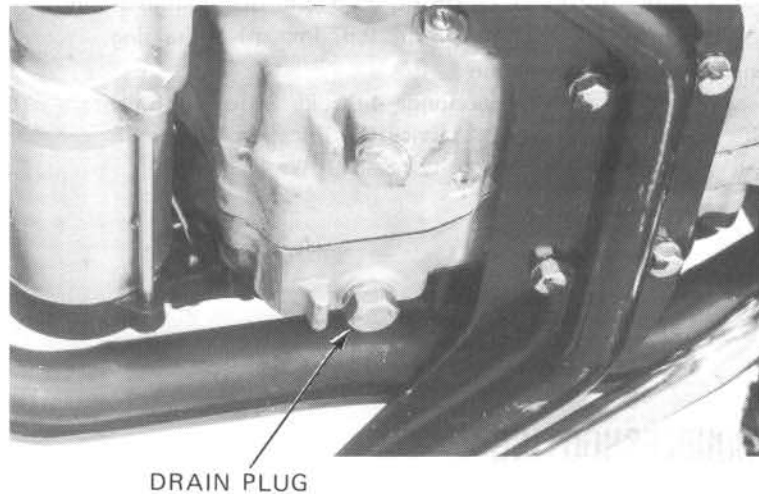

Clean the oil filter rotor (Page 2–3).

Fill the crankcase with the recommended grade of oil (Page 2–1).

ENGINE OIL CAPACITY:

1.1 lit (1.16 US qt, 0.97 Imp qt) after draining

Install the oil filler cap.

Start the engine and let it idle for a few minutes. Stop the engine.

With the ATC on level ground, make sure that the oil level is at the upper level mark and that there are no leaks.



OIL FILTER ROTOR AND SCREEN

NOTE

Clean the oil filter rotor before adding oil.

Remove the right crankcase and clutch outer covers (Page 8–3).

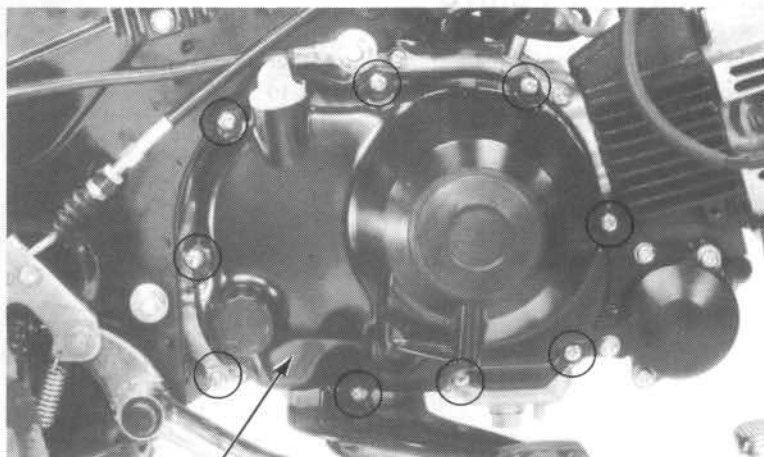

RIGHT CRANKCASE COVER

Clean the clutch outer cover and the inside of the clutch outer using clean, lint-free cloth.

NOTE

- Do not allow dust and dirt to enter the crankshaft oil passage.
- Do not use compressed air.

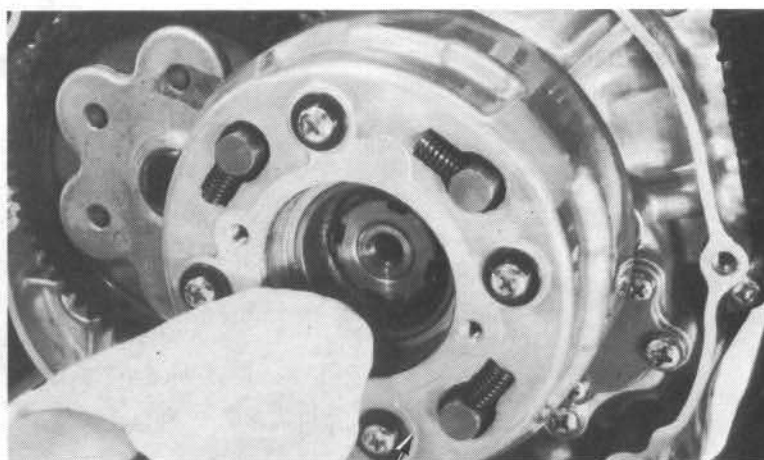

CLUTCH

Remove the oil filter screen from the crankcase.
Clean the filter screen.

Install the clutch outer and right crankcase covers (Page 8–12).
Fill the engine with recommended grade of oil (Page 2–1).

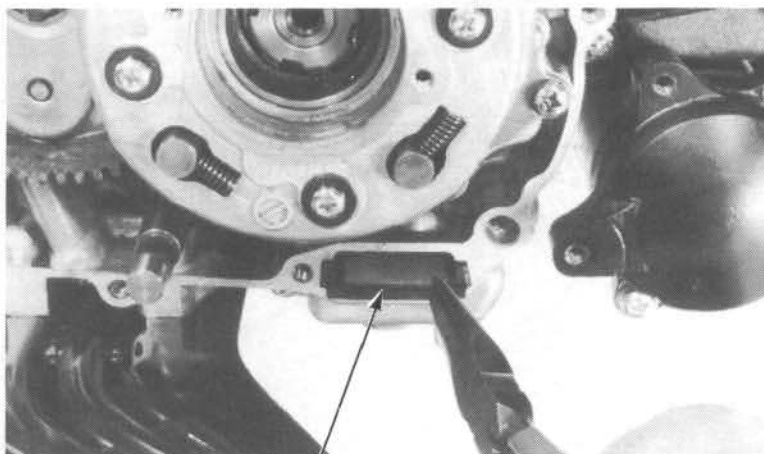

OIL FILTER SCREEN

LUBRICATION POINTS

Use general purpose grease when no other specification is given. Apply oil or grease to any 2 sliding surfaces and cables not shown here.

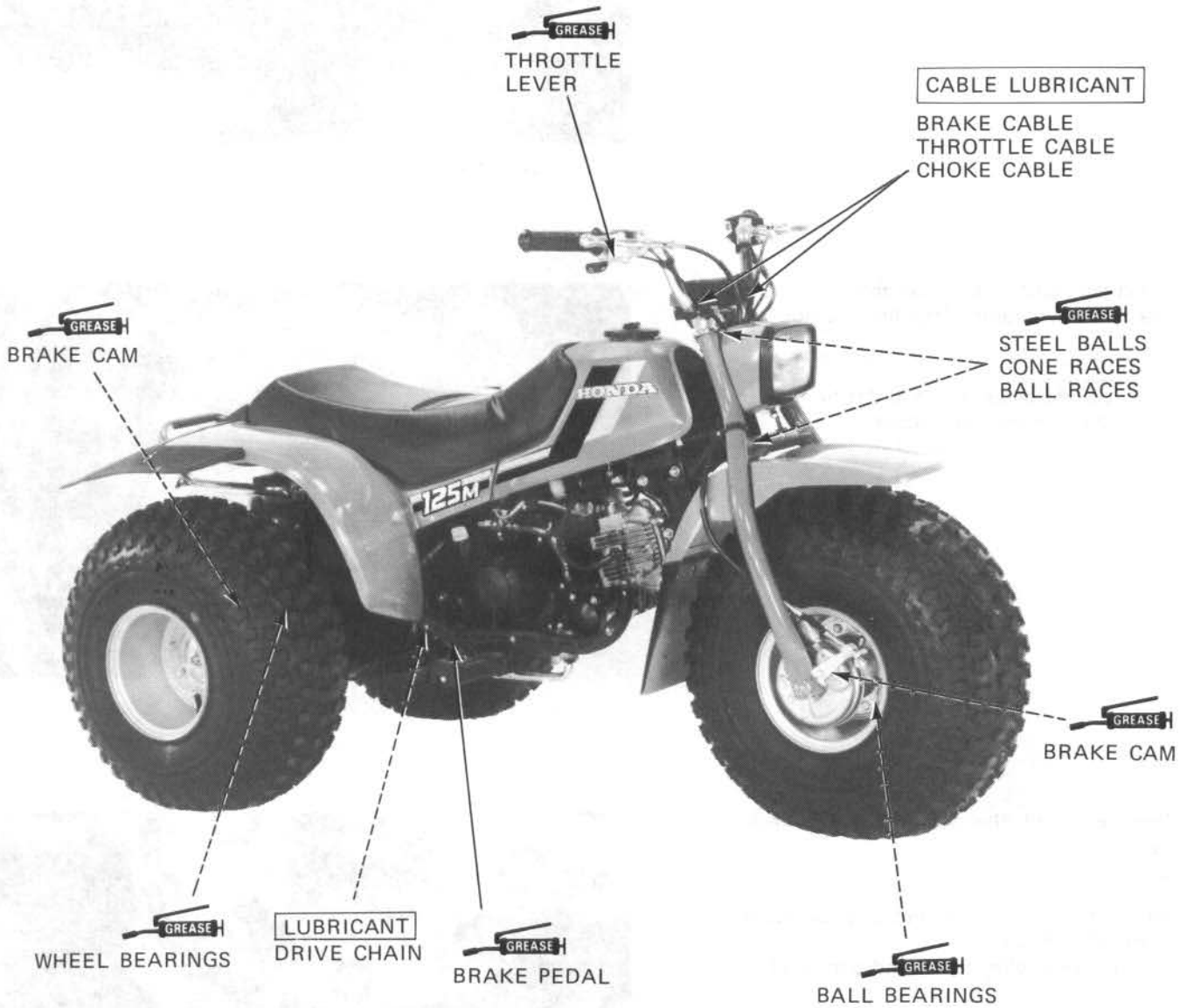

3. MAINTENANCE

SERVICE INFORMATION	3-1	BATTERY	3-10
MAINTENANCE SCHEDULE	3-3	DRIVE CHAIN	3-11
AIR CLEANER	3-4	BRAKE SHOES	3-13
SPARK PLUG	3-5	FRONT BRAKE	3-14
VALVE CLEARANCE	3-5	REAR BRAKE	3-14
CAM CHAIN TENSION	3-6	CLUTCH	3-16
CARBURETOR IDLE SPEED	3-7	SPARK ARRESTER CLEANING	3-16
FUEL LINES	3-7	NUTS, BOLTS, FASTENERS	3-17
FUEL STRAINER	3-8	LIGHTING EQUIPMENT	3-17
THROTTLE OPERATION	3-8	TIRES	3-18
IGNITION TIMING	3-9	STEERING HEAD BEARINGS	3-18
CYLINDER COMPRESSION	3-9		

SERVICE INFORMATION

SPECIFICATIONS

Ignition timing:

Initial	$10^{\circ} \pm 2^{\circ}$ BTDC at idle
Full advance	$32^{\circ} \pm 2^{\circ}$ BTDC at 3,400 rpm

Spark plug:

Spark plug gap	0.6–0.7 mm (0.024–0.028 in)
Recommended spark plugs	DR8ES-L (NGK) X24ESR-U (ND) RA6YC (CHAMPION)

Valve clearance (cold):

Intake	0.07 mm (0.003 in)
Exhaust	0.07 mm (0.003 in)

Throttle lever free play:

5–10 mm (3/16–3/8 in)

Idle speed:

$1,700 \pm 100$ rpm

Cylinder compression:

Standard	12.5 ± 1.5 kg/cm ² (177.8 \pm 21.3 psi)
Service limit	9.0 kg/cm ² (128.0 psi)

MAINTENANCE

Front brake lever free play	15–20 mm (5/8–3/4 in)
Rear brake pedal free play	15–20 mm (5/8–3/4 in)
Rear brake lever (parking brake) lever free play	15–20 mm (5/8–3/4 in)
Drive chain free play	10–20 mm (3/8–3/4 in)
Drive chain length (31 pins):	
Standard	381 mm (15.00 in)
Service limit	385 mm (15.16 in)
Front/rear rim size	8.25 x 8.0
Front/rear tire size	22 x 11–8.0
Front/rear tire pressure	2.2 psi (0.15 kg/cm ² , 15 kPa)
Front/rear tire circumference:	
Standard	1,742 mm (68.6 in)

TORQUE VALUES

Spark plug	12–19 N·m (1.2–1.9 kg·m, 9–14 ft·lb)
Valve adjuster cover	10–14 N·m (1.0–1.4 kg·m, 7–10 ft·lb)
Cam chain tensioner adjusting bolt	15–22 N·m (1.5–2.2 kg·m, 11–16 ft·lb)
Rear axle bearing holder bolt	50–70 N·m (5.0–7.0 kg·m, 36–51 ft·lb)
Clutch adjuster lock nut	19–25 N·m (1.9–2.5 kg·m, 14–18 ft·lb)
Valve adjuster lock nut	15–18 N·m (1.5–1.8 kg·m, 11–13 ft·lb)

TOOLS

Special	
Valve Adjuster	07908–KE90000 or 89201–200–000 (U.S.A. only)
Common	
Valve Adjusting Wrench, 8 x 9 mm	07708–0030100 or equivalent commercially available in U.S.A.

MAINTENANCE SCHEDULE

The maintenance intervals shown in the following schedule are based upon average riding conditions. ATC's subjected to severe use, or ridden in unusually wet or dusty areas, require more frequent servicing. Items marked * should be serviced by an authorized Honda dealer, unless the owner has the proper tools and is mechanically proficient. Other maintenance items are simple to perform and may be serviced by the owner.

Perform the Pre-ride Inspection in the Owner's Manual at each scheduled maintenance period.

- I: Inspect and Clean, Adjust, Lubricate or Replace, if necessary.
- C: Clean
- R: Replace
- A: Adjust
- L: Lubricate

	ITEM	INITIAL SERVICE PERIOD (First week of operation)	REGULAR SERVICE PERIOD (Every 30 operating days)	Ref. Page
*	ENGINE OIL (NOTE 1, 2)	R	R	2-2
*	OIL FILTER SCREEN		C	2-3
	AIR CLEANER ELEMENT (NOTE 2)		I	3-4
	SPARK PLUG		I	3-5
	BATTERY	I	I	3-10
*	VALVE CLEARANCE	I	I	3-5
*	CAM CHAIN TENSIONER ('84)	A	A	3-6
*	CARBURETOR	I	I	3-7
	FUEL LINE	I: (EVERY YEAR)		3-7
*	FUEL FILTER	C: (EVERY YEAR)		3-8
	THROTTLE OPERATION	I	I	3-8
	DRIVE CHAIN (NOTE2)	I.L	I.L	3-11
*	FRONT & REAR BRAKE SHOES (NOTE3)	I: (EVERY YEAR)		3-13
	FRONT & REAR BRAKE SYSTEM	I	I	3-14
*	CLUTCH	A	A	3-16
*	SPARK ARRESTER		C	3-16
	ALL NUTS, BOLTS, FASTENERS	I	I	3-17
	LIGHTING EQUIPMENT	I	I	3-17
	TIRES	I	I	3-18
*	STEERING HEAD BEARINGS	A: (EVERY YEAR)		3-18

- NOTES:
1. Replace every 30 operating days or every 3 months, whichever comes first.
 2. Service more frequently when riding in dust areas, sand or snow.
 3. Service more frequently after riding in very wet or muddy condition.

MAINTENANCE

AIR CLEANER

Remove the seat.
Remove the four wing bolts attaching the air cleaner case cover.

Remove the air cleaner case cover.

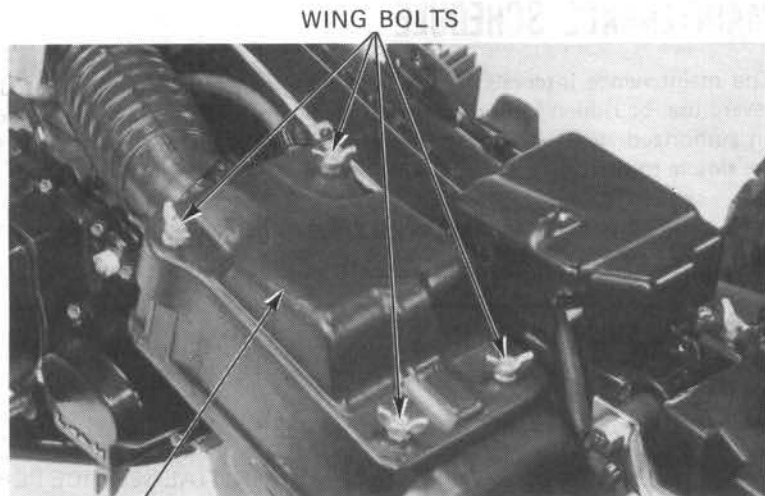

AIR CLEANER CASE COVER

Loosen the element holder band.
Remove the wing bolt and the element assembly from the air cleaner case.
Remove the air cleaner element from the holder.

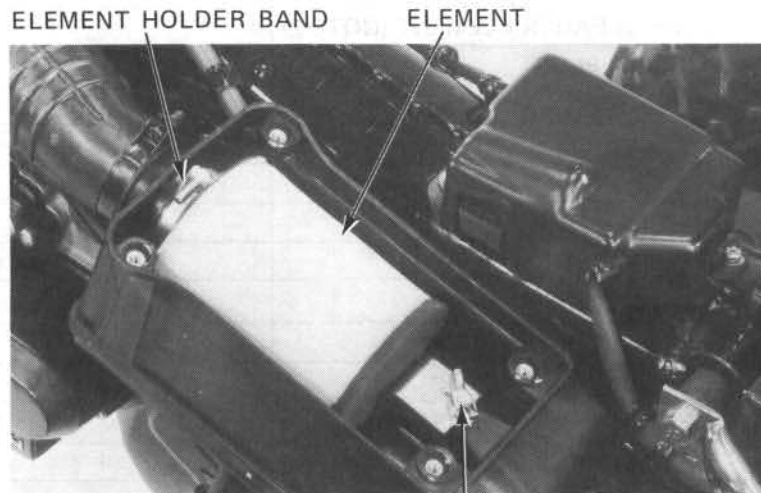

WING BOLT

Wash the element in non-flammable or high flash point solvent, squeeze out the solvent thoroughly, and allow to dry.

Soak the element in gear oil (SAE 80-90) and squeeze out the excess.
Place the element onto the element holder.

Install the element assembly into the air cleaner case.

Tighten the wing bolt and holder band.

Install the air cleaner case cover by using the four wing bolts.

Install the seat.

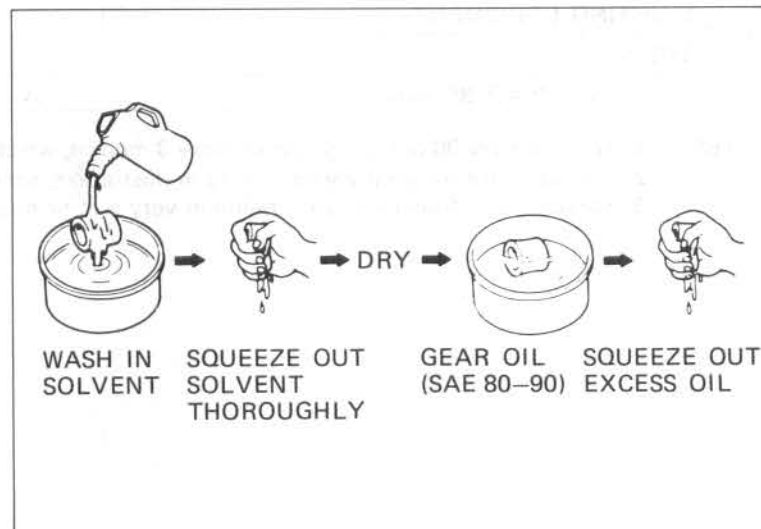

SPARK PLUG

Disconnect the spark plug cap and remove the spark plug.

Visually inspect the spark plug electrodes for wear. The center electrode should have square edges and the side electrode should have a constant thickness. Discard the spark plug if there is apparent wear or if the insulator is cracked or chipped. Measure the gap with a wire-type feeler gauge and adjust by carefully bending the side electrode.

SPARK PLUG GAP:

0.6–0.7 mm (0.024–0.028 in)

RECOMMENDED REPLACEMENT PLUG:

DR8ES-L (NGK)

X24ESR-U (ND)

RA6YC (CHAMPION)

Check the sealing washer and replace with a new one if damaged.

With the sealing washer attached, thread the spark plug in by hand to prevent cross-threading.

Tighten the spark plug to the specified torque.

**TORQUE: 12–19 N·m (1.2–1.9 kg·m,
9–14 ft·lb)**

Connect the spark plug cap.

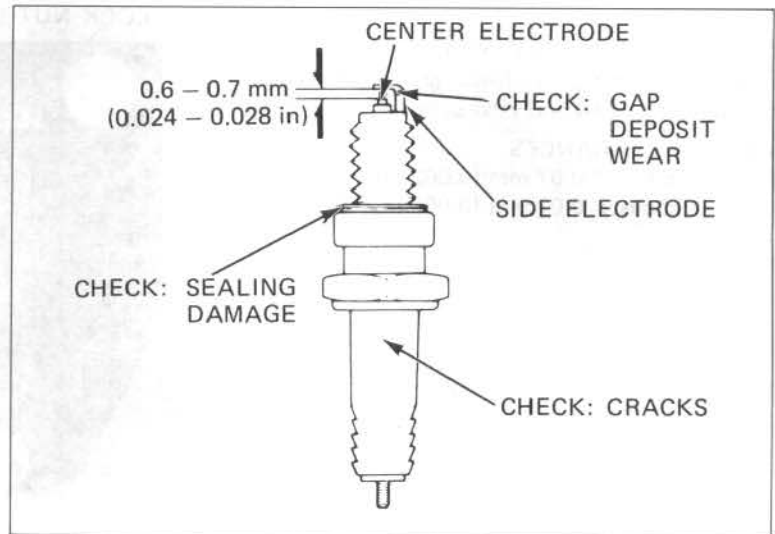

VALVE CLEARANCE

NOTE

Inspect and adjust valve clearance while the engine is cold (below 35°C/95°F).

Remove the timing mark hole cap.
Remove the valve adjuster covers.

Rotate the crankshaft by using the recoil starter and align the "T" mark on the rotor with the index mark. The piston must be at TDC of the compression stroke.



MAINTENANCE

Inspect the intake and exhaust valve clearances by inserting the feeler gauge between the adjusting screw and valve stem.

VALVE CLEARANCES:

(Cold) Intake: 0.07 mm (0.003 in)
Exhaust: 0.07 mm (0.003 in)

LOCK NUT

ADJUSTING SCREW

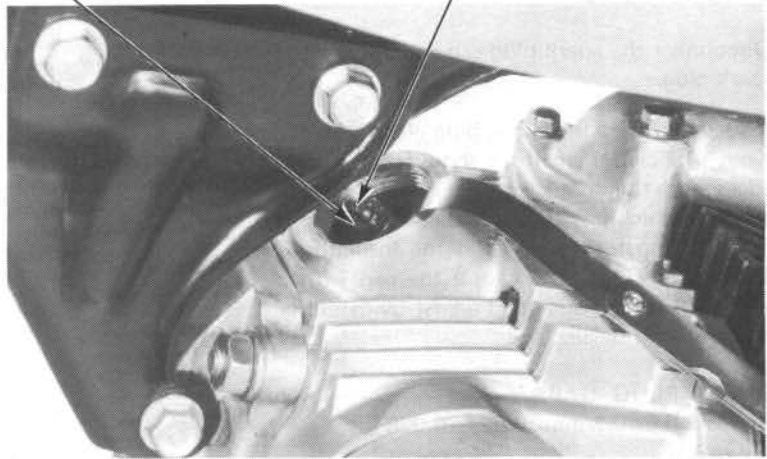

VALVE ADJUSTING WRENCH, 8 x 9 mm 07708-0030100
or equivalent commercially available in U.S.A.

Adjust by loosening the lock nut and turning the adjusting screw until there is a slight drag on the feeler gauge.

Hold the adjusting screw and tighten the lock nut.

**TORQUE: 15–18 N·m (1.5–1.8 kg-m,
11–13 ft-lb)**

Recheck the valve clearance and install the valve adjuster covers.

**TORQUE: 8–12 N·m (0.8–1.2 kg-m,
6–9 ft-lb)**

Install the timing hole cap.

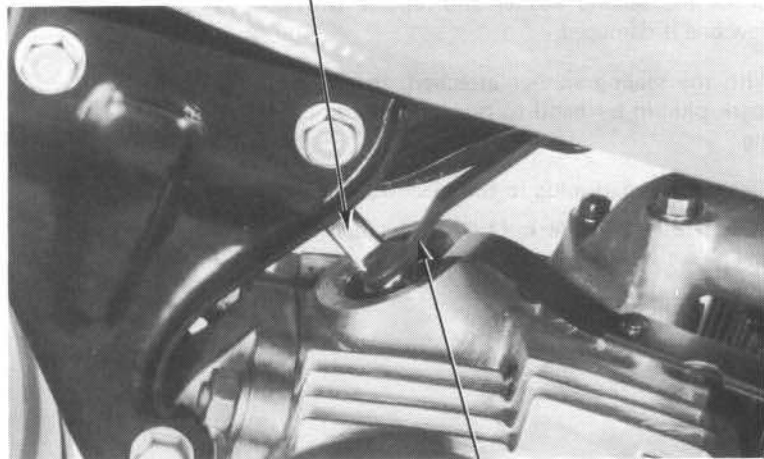

VALVE ADJUSTER 07908-KE90000
or 89201-200-000 (U.S.A. only)

CAM CHAIN TENSION

'84:

Start the engine and allow it to idle.
Loosen the lock nut and tensioner adjusting bolt approximately 1-1/2 turns.

After '84:

Cam chain tensioner is not adjustable.

'84 SHOWN

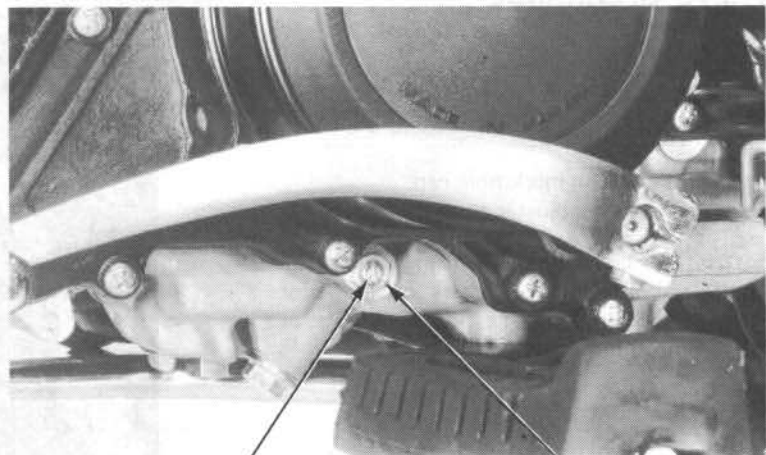

TENSIONER ADJUSTING BOLT

LOCK NUT

'84:

If the chain is still noisy, remove the 14 mm sealing bolt located on the left bottom side of the crankcase, and screw in the tensioner bolt until the cam chain becomes quiet.

Retighten the tensioner adjusting bolt, lock nut, and 14 mm sealing bolt.

After '84:

Cam chain tensioner is not adjustable.

'84 SHOWN

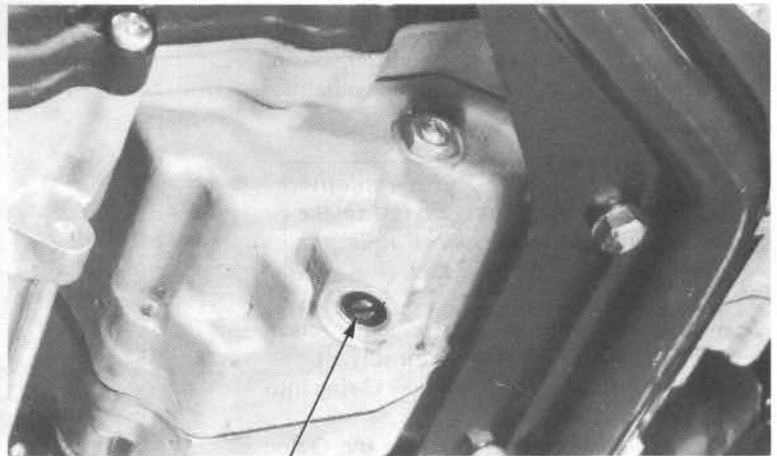

TENSIONER BOLT

CARBURETOR IDLE SPEED

NOTE

- Inspect and adjust the idle speed after all other maintenance items have been performed and are within specifications.
- The engine must be warm for accurate idle speed inspection and adjustment.

Warm up the engine.

Stop and go driving for ten minutes is sufficient.

Turn the throttle stop screw as required to obtain the specified idle speed.

IDLE SPEED: 1,700 ± 100 rpm

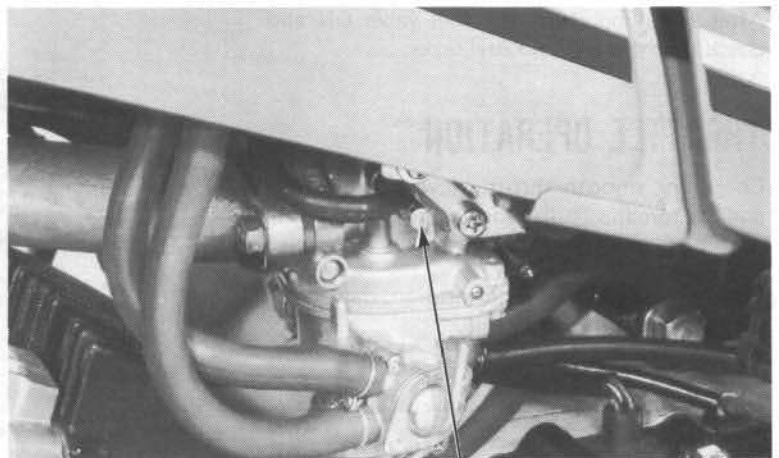

THROTTLE STOP SCREW

FUEL LINES

Replace any parts which show signs of deterioration, damage or leakage.

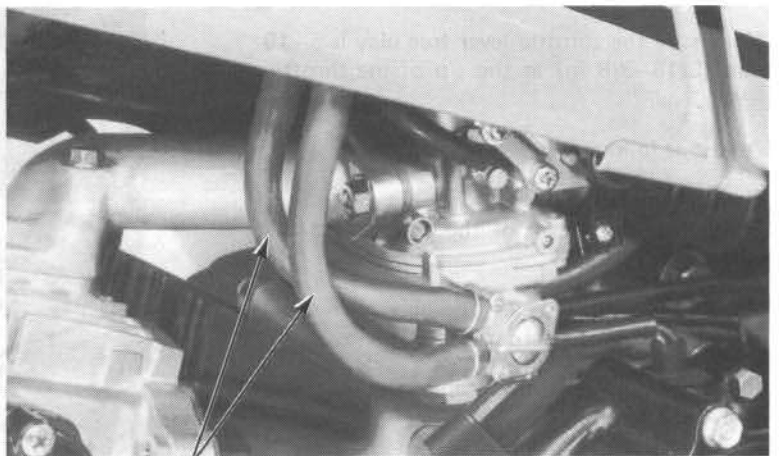

FUEL LINES

FUEL STRAINER

Turn the fuel valve OFF,
Remove the fuel cup, O-ring and filter screen,
draining the gasoline into a suitable container.

WARNING

Gasoline is flammable and is explosive under certain conditions. Do not smoke or allow flames or sparks near the equipment while draining fuel.

Wash the fuel cup and filter screen in clean non-flammable or high flash point solvent. Reinstall the filter screen and new O-ring into the carburetor.

Reinstall the fuel cup making sure the O-ring is in place. Finger-tighten the cup first, then torque it to specification.

TORQUE: 3–5 N·m (0.3–0.5 kg·m, 2–4 ft·lb)

After installing, turn the fuel valve ON and check that there are no fuel leaks.

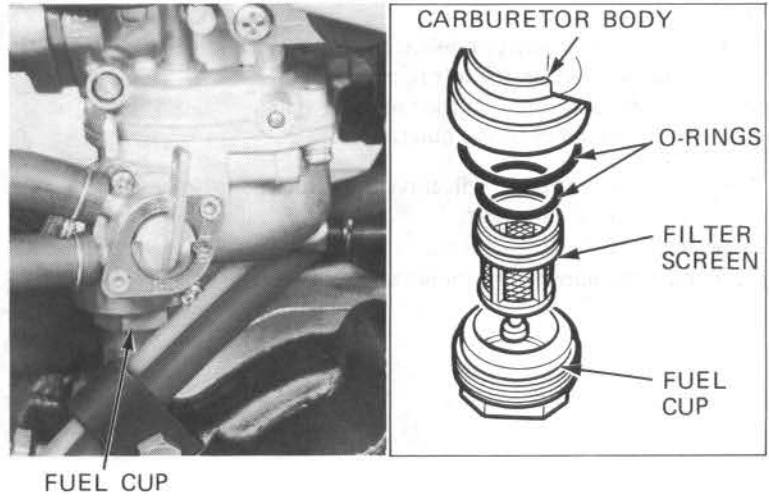

THROTTLE OPERATION

Check for smooth throttle lever full opening and automatic full closing in all steering positions.

Make sure there is no deterioration, damage or kinking in the throttle cable. Replace any damaged parts.

Disconnect the throttle cable at the upper end.

Thoroughly lubricate the cable and pivot point with a commercially available cable lubricant to prevent premature wear.

Install the throttle cable in the reverse order of removal.

Make sure the throttle lever free play is 5–10 mm (3/16–3/8 in) at the tip of the throttle lever.

Adjust as follows:

Remove the fuel tank.
Slide the rubber cap of the adjuster on the carburetor top.

Adjust the throttle lever free play by turning the adjuster on the carburetor.

Install the adjuster rubber cap securely.
Install the fuel tank.

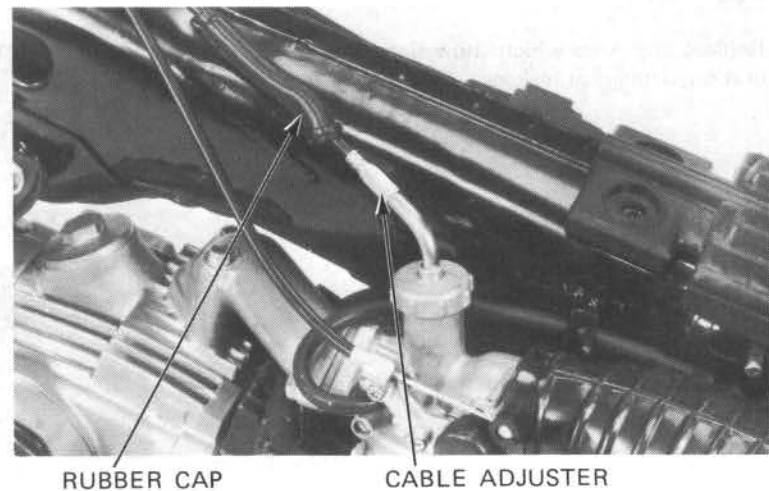
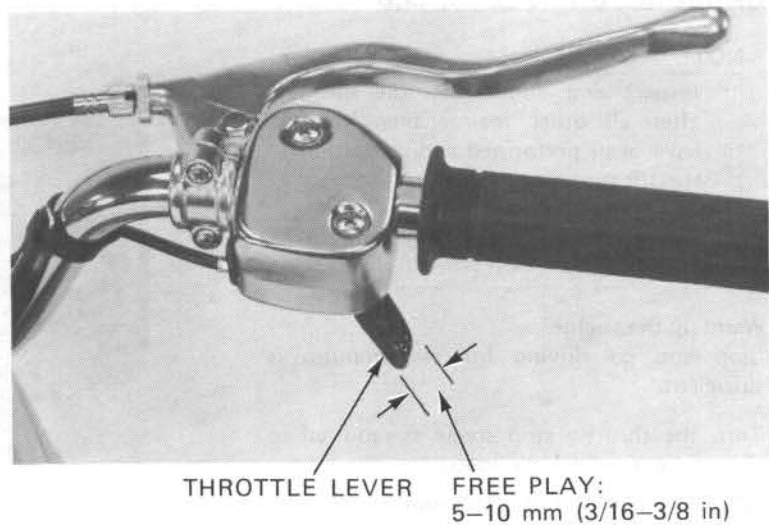

IGNITION TIMING

NOTE

The Capacitive Discharge Ignition (CDI) system is factory pre-set and does not require adjustment. To inspect the function of the CDI components, ignition timing inspection procedures are given here.

Remove the timing hole cap.
Connect a tachometer and timing light.
Start the engine and allow to idle.

IDLE SPEED: 1,700 ± 100 rpm

Inspect the ignition timing.
Timing is correct, if the "F" mark on the alternator rotor is aligned with the index mark on the left crankcase cover at idle.

If the ignition timing is incorrect, refer to Section 15.

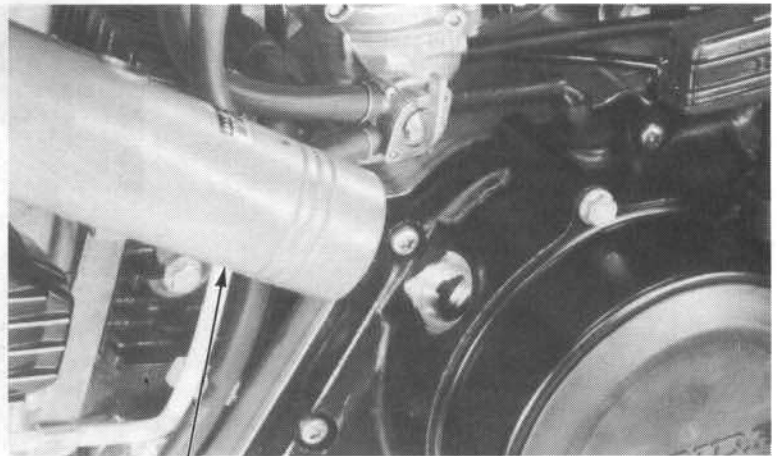

TIMING LIGHT

CYLINDER COMPRESSION

Warm up the engine.
Stop the engine and remove the spark plug.
Insert a compression gauge.

Raise the choke lever all the way up.
Fully open the throttle.
Operate the recoil starter several times.

NOTE

Watch for compression leaks at the gauge connection.



COMPRESSION GAUGE

COMPRESSION:

STANDARD:

12.5 ± 1.5 kg/cm² (177.8 ± 21.3 psi)

SERVICE LIMIT:

9.0 kg/cm² (128.0 psi)

Low compression can be caused by:

- Improper valve adjustment
- Valve leakage
- Worn piston ring or cylinder

High compression can be caused by:

- Carbon deposits in combustion chamber or on piston crown

BATTERY

Remove the seat by pulling the seat lever.
Remove the battery holder and cover by loosening the wing bolts.

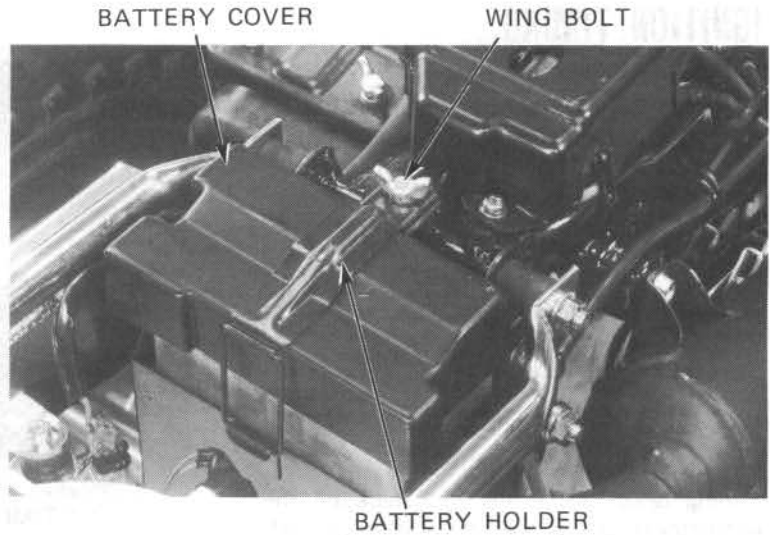

Inspect the battery fluid level.
When the fluid level nears the lower level, refill with distilled water to the upper level.

NOTE

Add only distilled water. Tap water will shorten the service life of the battery.

WARNING

- *The battery electrolyte contains sulfuric acid. Protect your eyes, skin and clothing. If electrolyte in your eyes, flush thoroughly with water and contact a doctor.*
- *Batteries produce explosive gases. Keep sparks, flames and cigarettes away.*

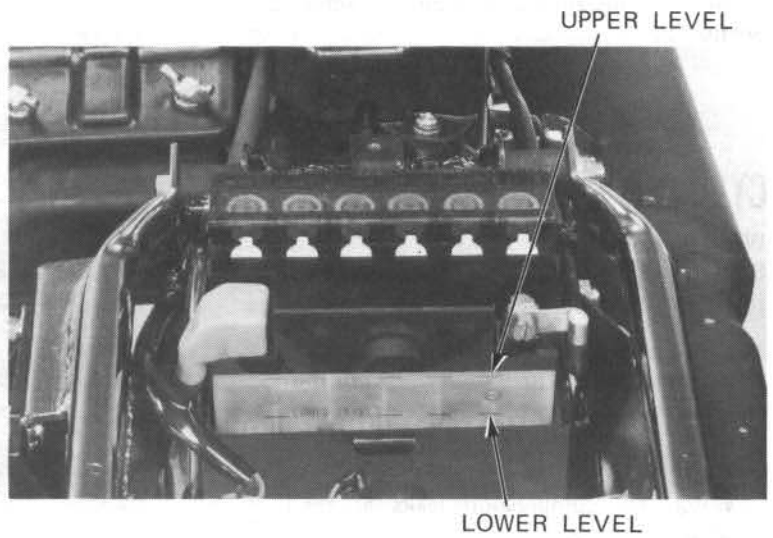

CAUTION

The battery breather tube must be routed as shown on the label attached on the tool box. Do not bend or twist the breather tube. A bent or kinked breather tube may pressurize the battery and damage its case, causing electrolyte leakage.

Replace the battery if sulphation forms or sediments (paste) accumulate on the bottom.

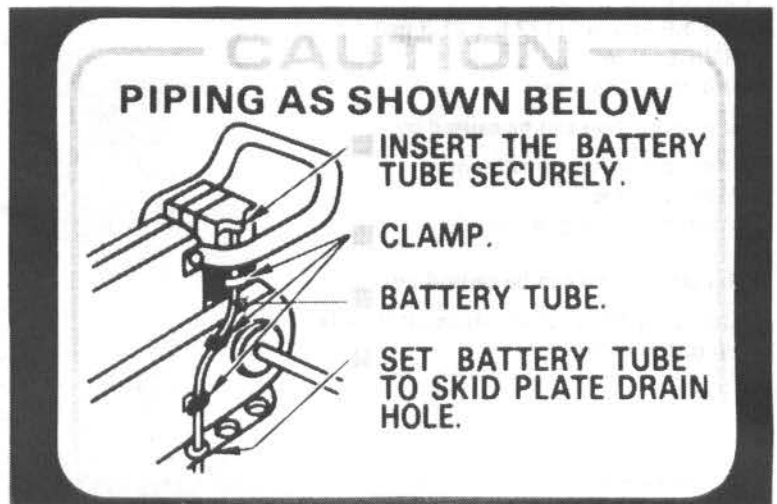

DRIVE CHAIN

Stop the engine and shift the transmission into neutral.

Remove the drive chain inspection hole cap.

Check the amount of chain free play through the inspection hole.

CHAIN FREE PLAY: 10–20 mm
(3/8–3/4 in)

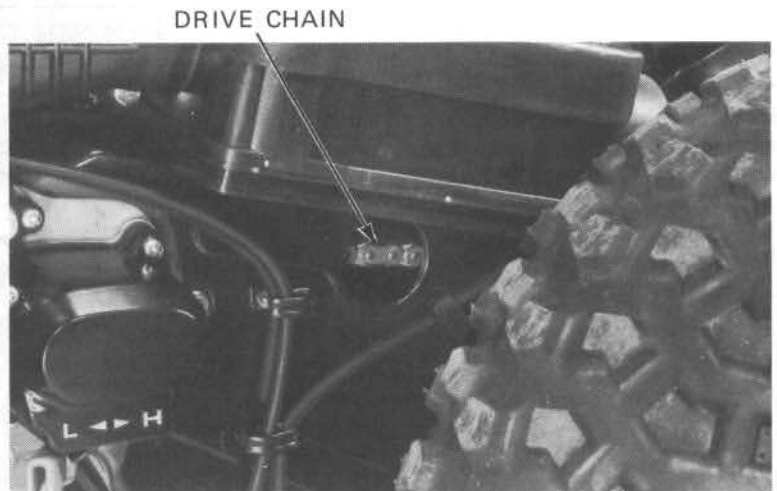

Adjust as follows:

Loosen the rear axle bearing holder bolts. Turn the adjusting nut to obtain the specified free play.

Retighten the rear axle bearing holder bolts.

TORQUE: 50–70 N·m (5.0–7.0 kg-m,
36–51 ft-lb)

Check the rear wheels for free rotation. Adjust the rear brake (Page 3-14).

Lubricate the drive chain with SAE 80 or 90 gear oil lubricant through the inspection hole.

Install the inspection hole cap.

REAR WHEEL BEARING HOLDER BOLTS

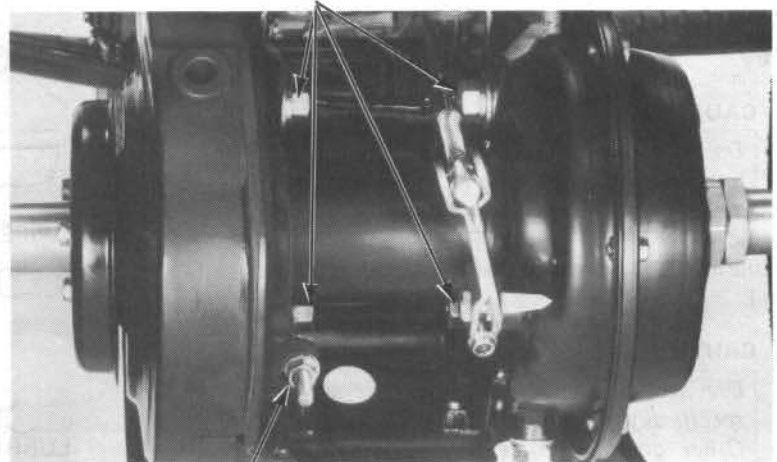

ADJUSTING NUT

When the drive chain becomes extremely dirty, it should be removed and cleaned prior to lubrication.

Remove the left axle nut and left rear wheel with the hub (Page 13-4).

Remove the frame skid plate (Page 13-4).

Remove the sealed cover and chain case bolts (Page 13-4).

Remove the drive chain cover (Page 13-4).

Remove the retainer clip, master link, four O-rings, and drive chain.

RETAINER CLIP

MASTER LINK

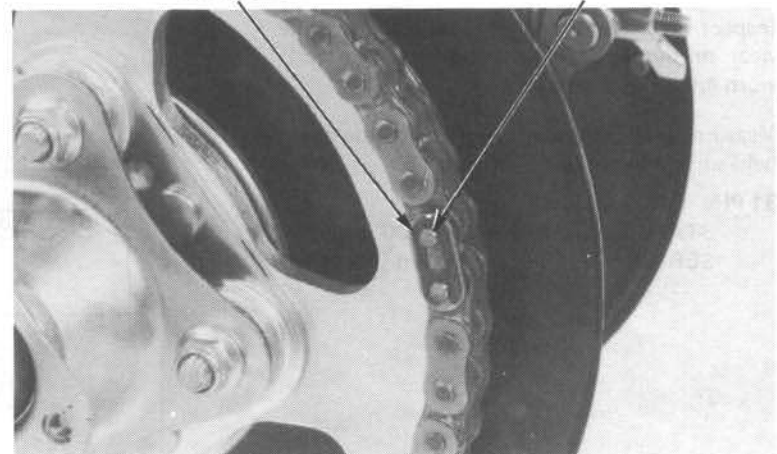

MAINTENANCE

The drive chain is equipped with grease-retaining O-rings inside the chain to improve its service life. However, special precautions must be taken when adjusting, lubricating, washing and replacing the chain.

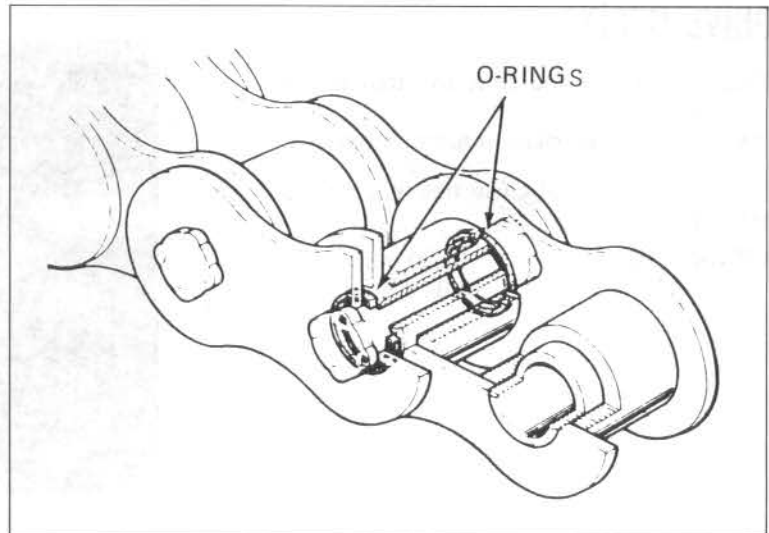

Clean the drive chain with kerosene and wipe dry.

CAUTION

Do not use a steam cleaner, high pressure washers or solvents as these will damage the O-rings.

Lubricate the drive chain with SAE 80 or 90 gear oil.

CAUTION

Use aerosol chain lubricants that are specifically for O-ring equipped chains. Other aerosol lubricants may contain solvents which could damage the O-rings.

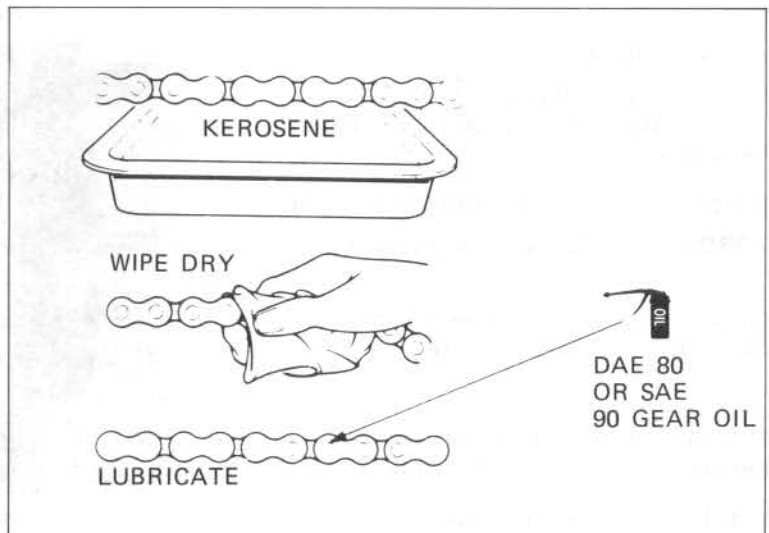

Inspect the drive chain and O-rings for possible wear or damage. Replace the chain, if it is worn excessively or damaged.

Measure the drive chain length with the chain held so that all links are straight.

31 PIN LENGTH:

STANDARD: 381 mm (15.00 in)

SERVICE LIMIT: 385 mm (15.16 in)

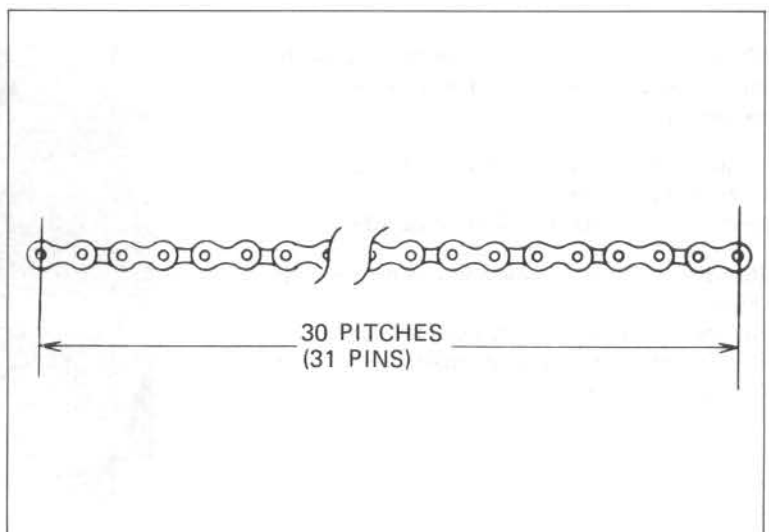

Inspect the sprocket teeth for excessive wear or damage. Replace if necessary.

NOTE

Never install a new drive chain on worn sprockets or a worn chain on new sprockets. Both chain and sprockets must be in good condition, or the new replacement chain or sprockets will wear rapidly.

To remove the drive sprocket, remove the left crankcase cover and subtransmission (Section 10).

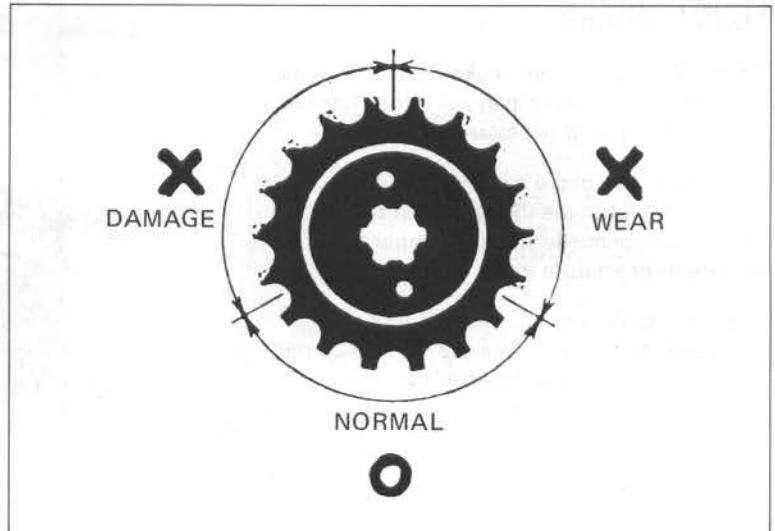

Install the drive chain in the reverse order of removal noting the chain clip direction.

CAUTION

- Do not assemble the drive chain without the four O-rings.
- Be sure that there is no space between the master link and chain retainer clip.

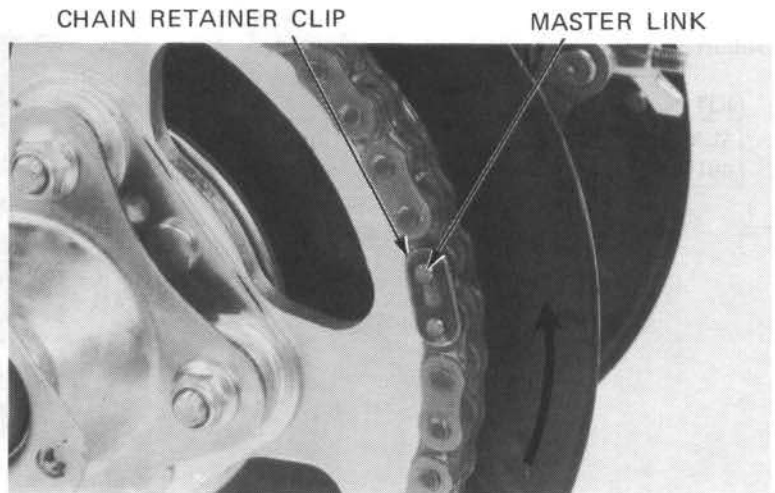

BRAKE SHOES

Replace the brake shoes if the indicator plate aligns with the brake panel index mark when the front brake lever, rear brake lever or pedal is applied.

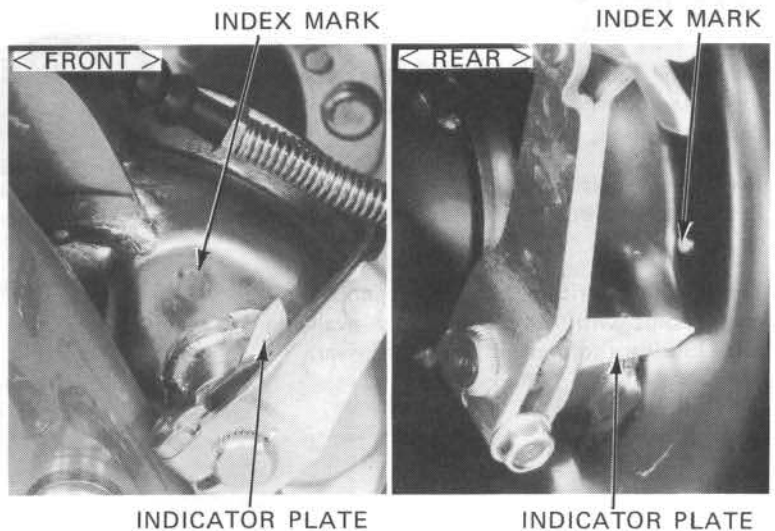

FRONT BRAKE

Check the cable and brake lever for loose connections, excessive play, or other damage. Replace or repair if necessary.

Disconnect the brake cable at the upper end. Thoroughly lubricate the cable and pivot point with a commercially available cable lubricant to prevent premature wear.

Install the brake cable. Make sure brake lever free play is 15–20 mm (5/8–3/4 in) at the brake lever tip.

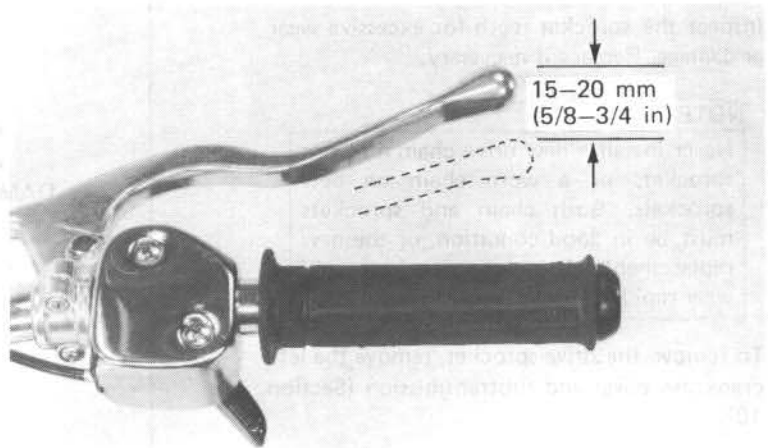

Adjust free play by turning the adjusting nut.

NOTE

Make sure the cut-out of the adjusting nut is seated on the brake arm pin.

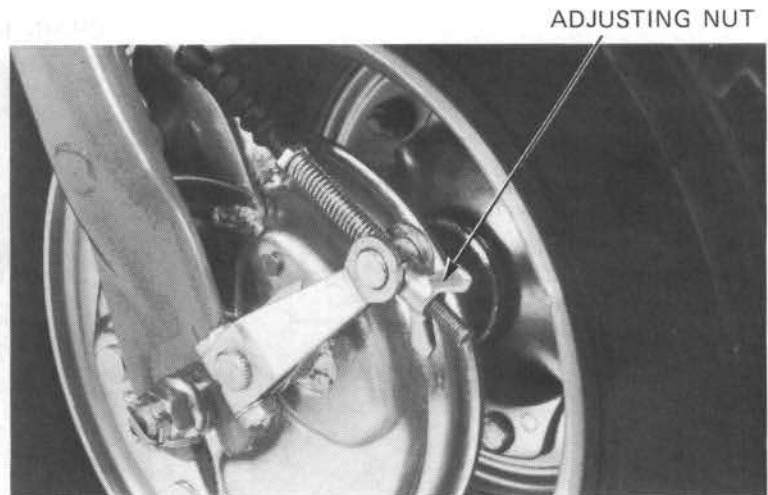

REAR BRAKE

Check the cable, brake lever and brake pedal for loose connections, excessive play, or other damage.

Replace or repair if necessary. Disconnect the brake cables at the brake lever or pedal ends.

Thoroughly lubricate the cables and their pivot point with a commercially available cable lubricant to prevent premature wear.

Install the cables.

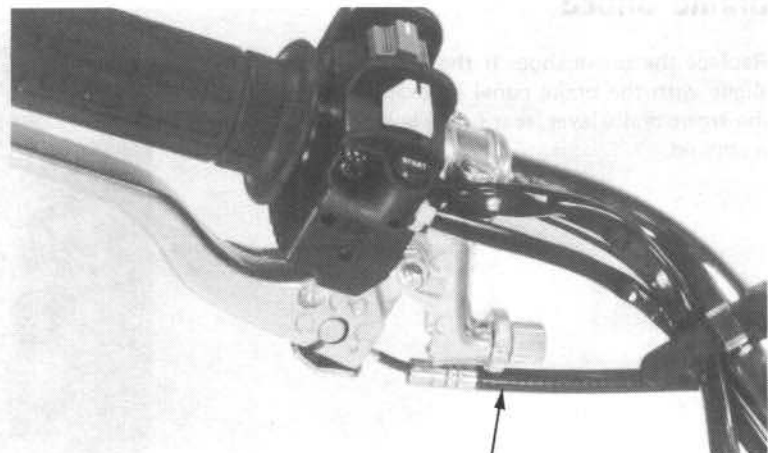

Measure the brake lever (Parking brake) free play at the end of the brake pedal.

BRAKE LEVER FREE PLAY:
15–20 mm (5/8–3/4 in)

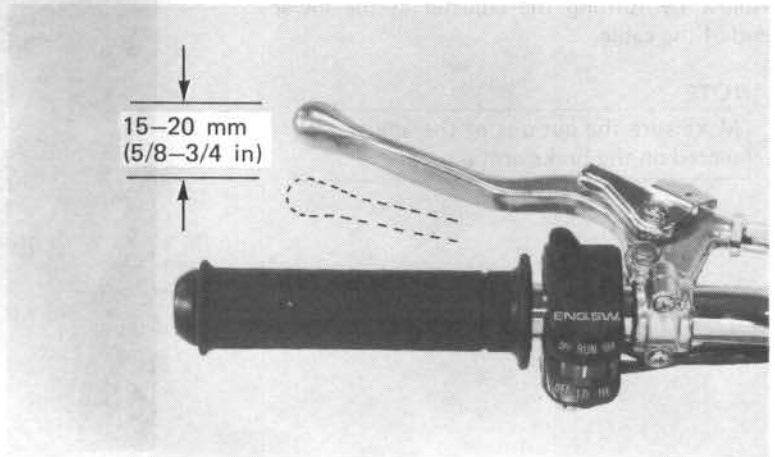

Adjust by loosening the lock nut and turning the lever adjusting nut. Tighten the lock nut securely.

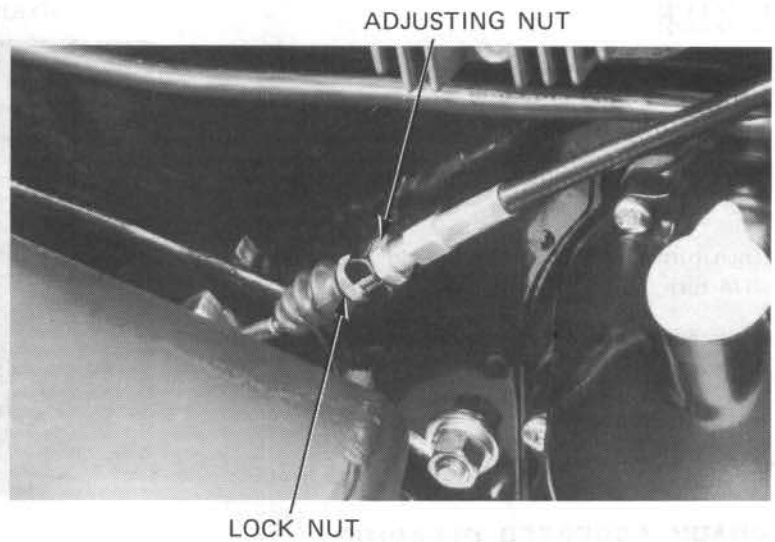

Measure the rear brake pedal free play at the end of the brake lever.

REAR BRAKE PEDAL FREE PLAY:
15–20 mm (5/8–3/4 in)

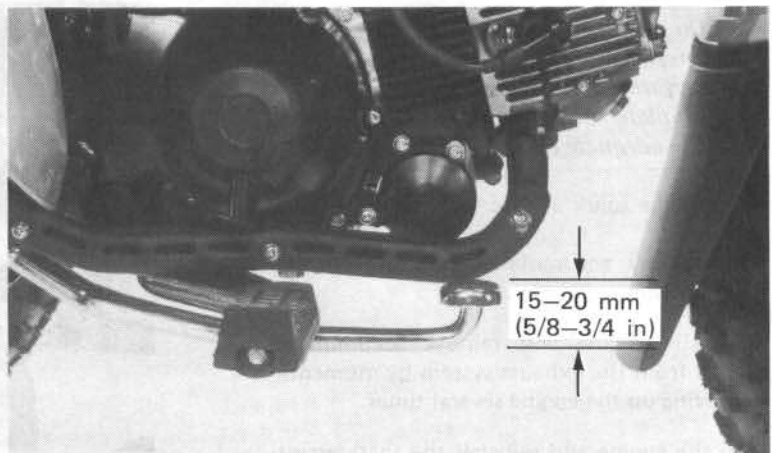

MAINTENANCE

Adjust by turning the adjuster at the lower end of the cable.

NOTE

Make sure the cut-out of the adjuster is seated on the brake arm pin.

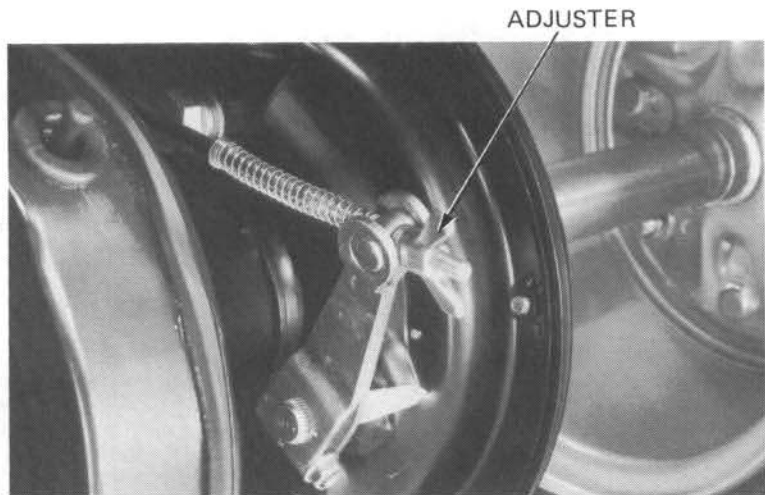

CLUTCH

Stop the engine.
Remove the adjuster cap.
Loosen the clutch adjusting screw lock nut.

Slowly turn the adjusting screw counterclockwise until resistance is felt.

Then turn the adjusting screw clockwise 1/8 - 1/4 turn, and tighten the lock nut.

After adjustment, start the engine and check for proper clutch operation.

Install the adjuster cap.



SPARK ARRESTER CLEANING

'84:

WARNING

- Do not remove and install the spark arrester while the exhaust pipe is hot.
- Perform this operation in a well-ventilated area, free from fire hazard.
- Use adequate eye protection.

Remove the spark arrester bolts and the spark arrester.

Remove any accumulated carbon from the spark arrester.

Start the engine and remove accumulated carbon from the exhaust system by momentarily revving up the engine several times.

Stop the engine and reinstall the spark arrester.

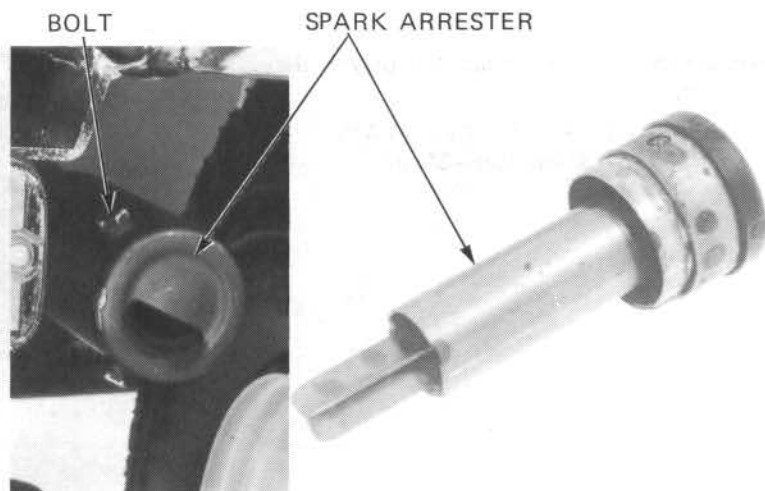

After '84:

WARNING

- The exhaust system becomes very hot even after short periods of engine operation.
- To avoid fire hazards, do not perform this maintenance near flammable materials.
- Use adequate eye protection.

Remove the spark arrester bolt and sealing washer.

Start the engine and purge accumulated carbon from the system by momentarily revving up the engine several times.

Stop the engine and allow the exhaust pipe to cool.

Check that the sealing washer is in good condition.

Reinstall the spark arrester bolt with the sealing washer and tighten it to 30–40 N•m (3.0–4.0 kg•m, 22–29 ft-lb).

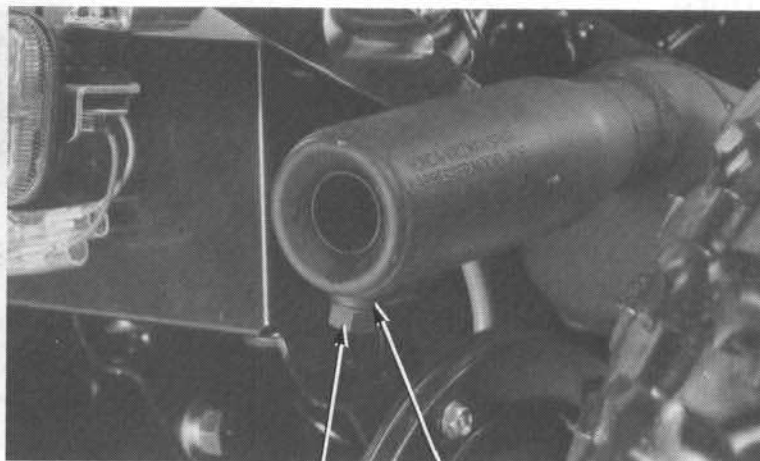

SPARK ARRESTER BOLT SEALING WASHER

NUTS, BOLTS, FASTENERS

Tighten bolts, nuts and fasteners at regular intervals shown in the Maintenance Schedule (Page 3-3).

Check that all chassis nuts and bolts are tightened to their correct torque values (Page 1-5). Check that all cotter pins and safety clips are in place.

LIGHTING EQUIPMENT

Apply the parking brake lever.
Start the engine.

Check the headlight and taillight by operating the lighting switch.

position	Function
OFF	Headlight and taillight are OFF.
LO	Headlight low beam and taillight should be ON.
HI	Headlight high beam and taillight should be ON.

If the lights do not work properly, check the bulbs and refer to page 18–6 to test the switch if necessary.

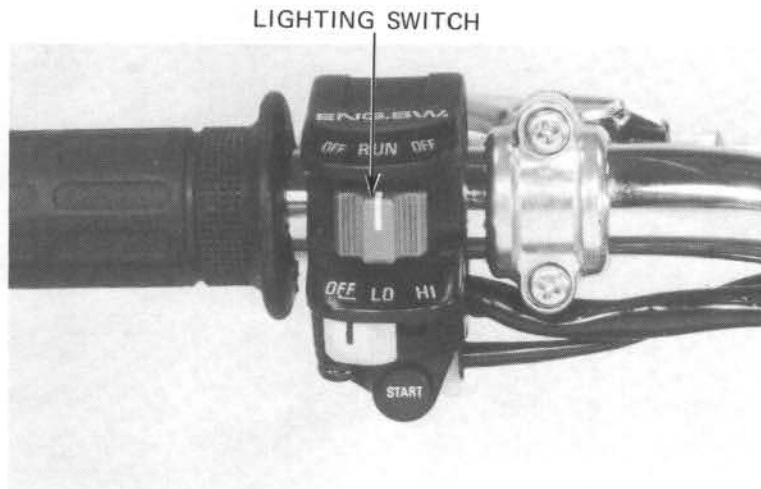

TIRES

Check the tire for cuts, imbedded nails, or other sharp objects.

NOTE

Tire pressure should be checked when the tires are COLD.

Check the tire pressure.

TIRE PRESSURES:

Recommended pressure:

2.2 psi (0.15 kg/cm², 15 kPa)

Minimum pressure:

1.7 psi (0.12 kg/cm², 12 kPa)

STANDARD TIRE CIRCUMFERENCE

1,742 mm (68.6 in)

Maximum pressure:

2.6 psi (0.18 kg/cm², 18 kPa)



STEERING HEAD BEARINGS

NOTE

Make sure the cables do not interfere with the rotation of the handlebar.

Raise the front wheel off the ground and make sure that the handlebar rotates freely.

If the handlebar moves unevenly, binds or has vertical movement, adjust the steering head bearing by turning the steering head adjusting nut with a lock nut wrench (Page 12–21).



HEAD BEARINGS

MEMO

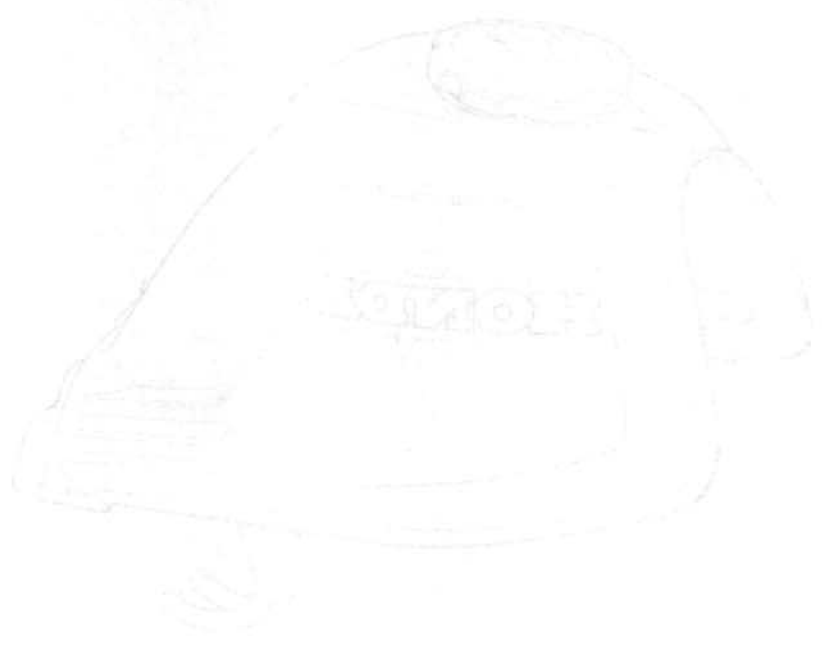

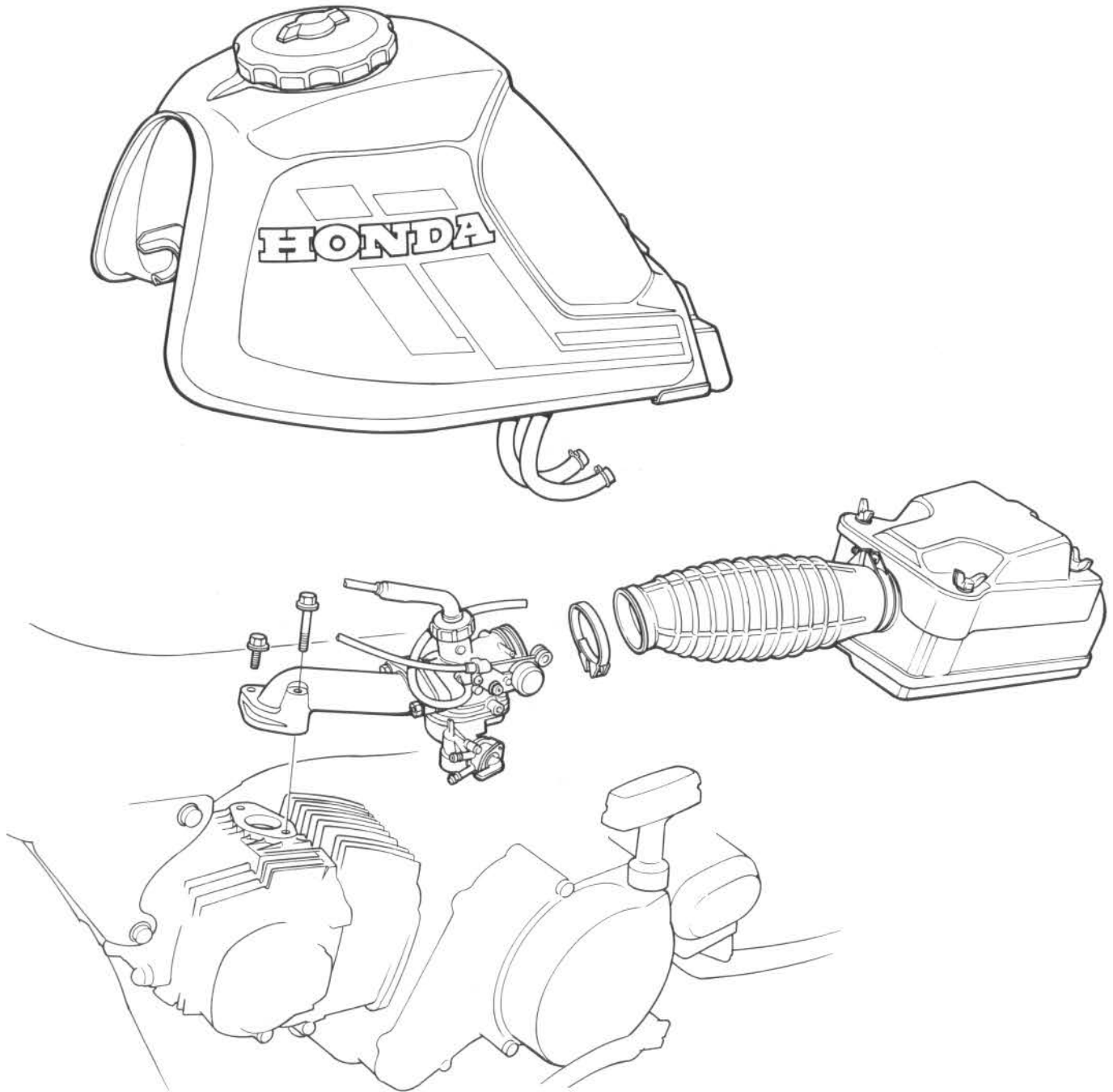

4. FUEL SYSTEM

SERVICE INFORMATION	4-1
TROUBLESHOOTING	4-2
FUEL TANK	4-3
AIR CLEANER CASE	4-4
CRANKCASE BREATHER	4-5
THROTTLE VALVE DISASSEMBLY	4-6
CARBURETOR REMOVAL	4-7
FLOAT, FLOAT VALVE AND JETS	4-8
CARBURETOR ASSEMBLY	4-10
FLOAT LEVEL MEASUREMENT	4-10
CARBURETOR INSTALLATION	4-11
THROTTLE VALVE ASSEMBLY	4-11
PILOT SCREW ADJUSTMENT	4-12
HIGH ALTITUDE ADJUSTMENT	4-12

SERVICE INFORMATION

GENERAL

WARNING

- Use caution when working with gasoline. Always work in a well ventilated area away from sparks or flames.
- When disassembling fuel system parts, note the locations of the O-rings. Replace them during reassembly.

SPECIFICATIONS

< Fuel tank >

Fuel tank capacity	7.7 lit (2.0 US gal, 1.70 Imp gal)
Fuel reserve capacity	0.5 lit (0.13 US gal, 0.11 Imp gal)

< Carburetor >

Identification mark	PB20A
Main jet	#92
Slow jet	#38
Jet needle setting	2nd groove from the top
Air screw opening	1-3/8 turns out
Float height	10.7 mm (0.43 in)
Idle speed	1,700 ± 100 rpm

TOOL

Common

Float Level Gauge 07401-0010000

TROUBLESHOOTING

Engine cranks but won't start.

1. No fuel in tank
2. No fuel to cylinder
3. Too much fuel getting to cylinder
4. No spark at plug (ignition malfunction)
5. Air cleaner clogged

Engine idles roughly, stalls, or runs poorly

1. Idle speed incorrect
2. Ignition malfunction
3. Rich mixture
4. Lean mixture
5. Air cleaner dirty
6. Insulator leaks

Lean mixture

1. Carburetor fuel jet clogged
2. Fuel cap vent blocked
3. Fuel filter clogged
4. Fuel line kinked or restricted
5. Float valve faulty
6. Float level too low

Rich mixture:

1. Carburetor choke stuck closed
2. Flat valve faulty
3. Flat level too high
4. Carburetor air jet clogged
5. Air cleaner dirty

FUEL TANK

Remove the seat by pulling the lever.
Turn the fuel valve OFF, and disconnect the fuel lines by the two screws attaching the fuel valve to the fuel valve body.

WARNING

Keep gasoline away from flames or sparks. Wipe up spilled gasoline at once.

Use a drain pan and check that fuel flows freely out of the fuel valve. If flow is restricted, clean the fuel strainer (Page 3-8). Install the fuel tank. Install the fuel valve onto its body.

Install the seat.

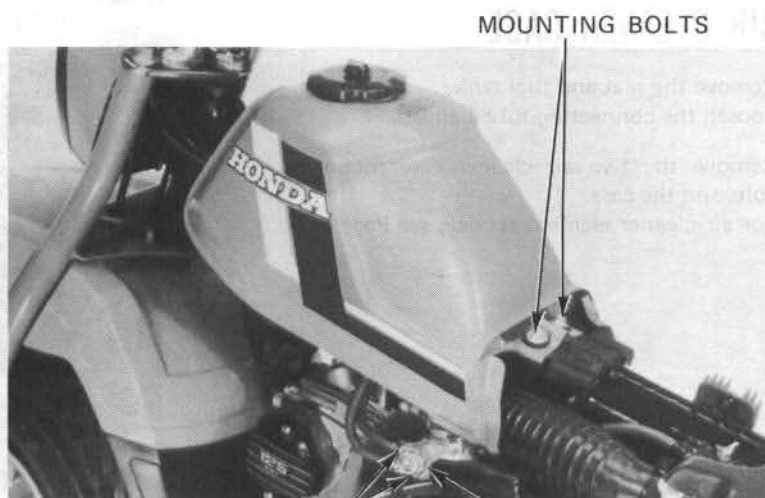

FUEL VALVE SCREWS VALVE BODY

NOTE

- Be sure the front fuel tank brackets are on the rubber cushions.
- After assembly, make sure there are no fuel leaks.

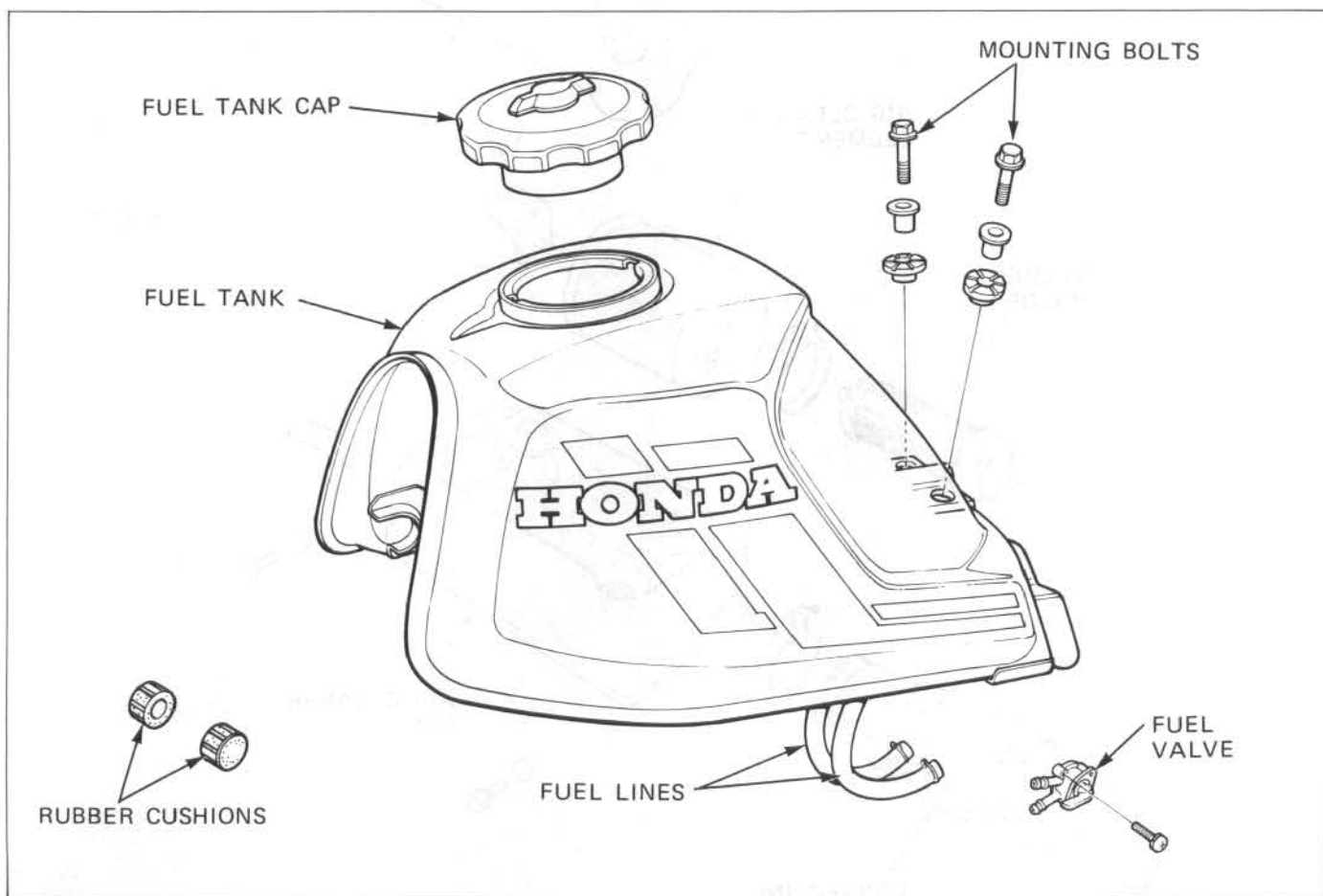

AIR CLEANER CASE

Remove the seat and fuel tank.
Loosen the connecting tube bands.

Remove the two air cleaner case mounting bolts and the case.
For air cleaner element service, see Page 3-4.

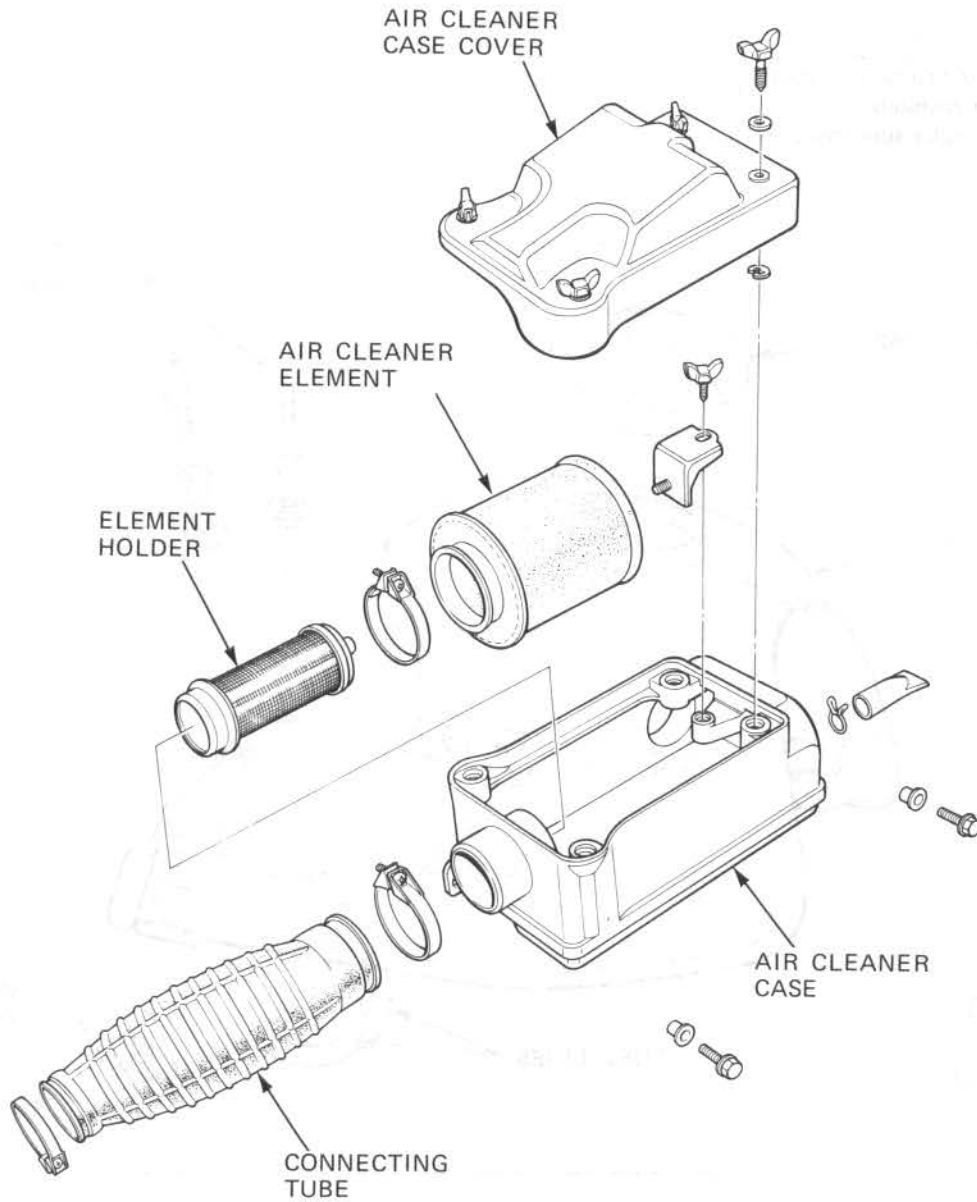
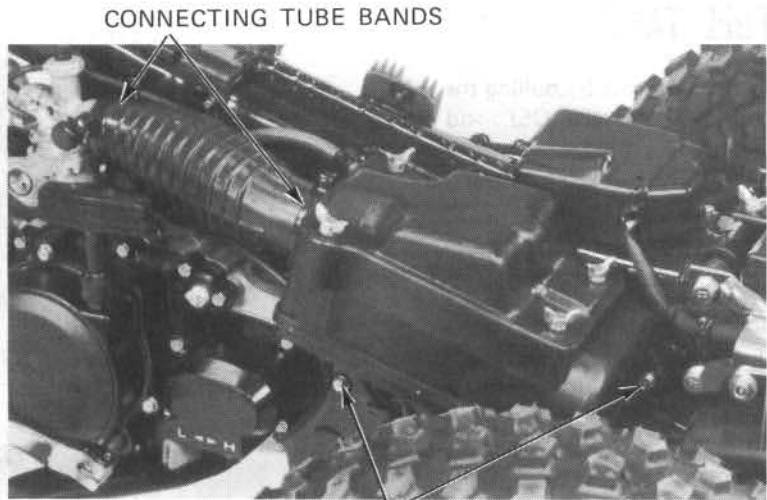

CRANKCASE BREATHER

Route the crankcase breather tube as shown.

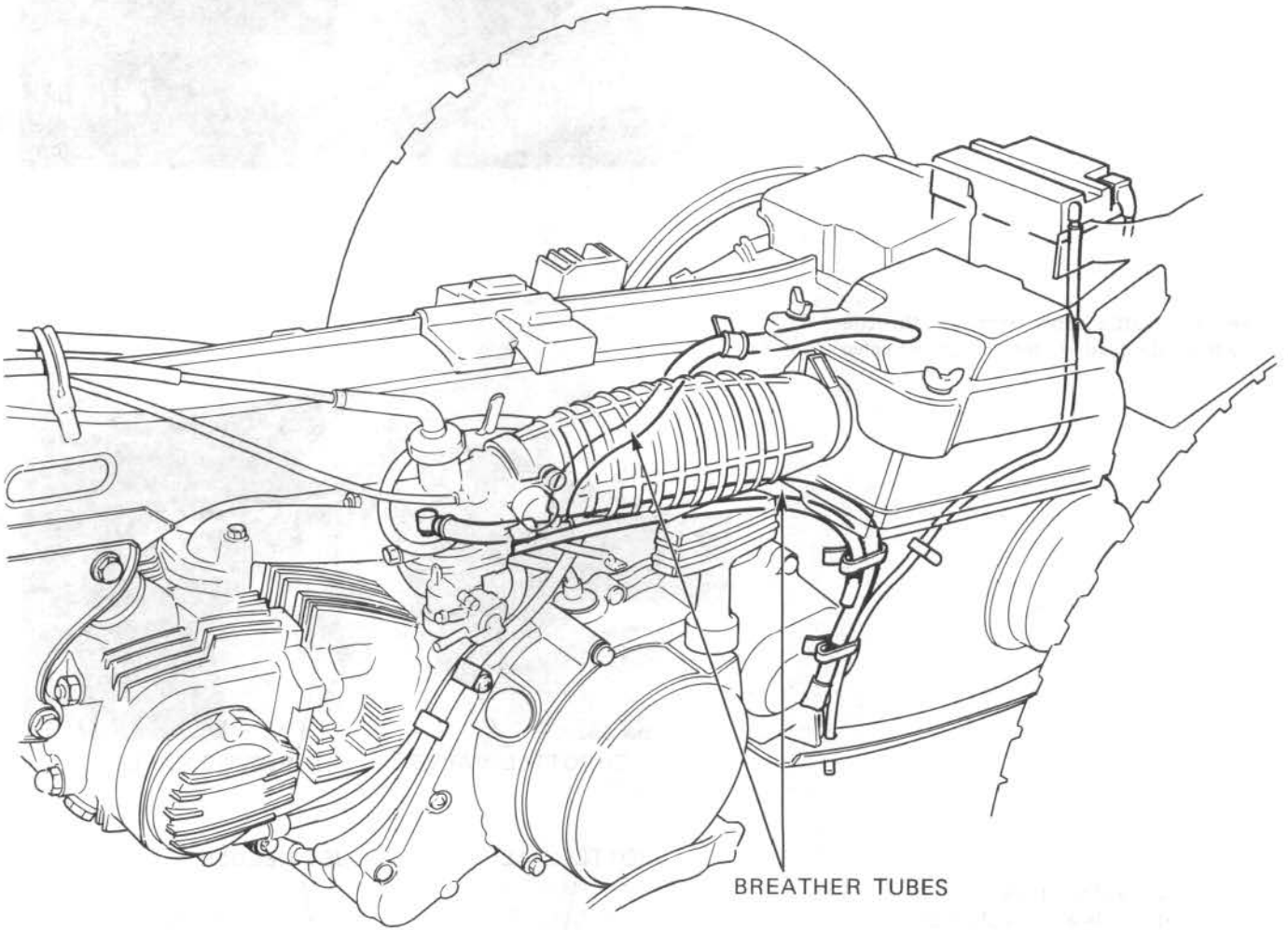

THROTTLE VALVE DISASSEMBLY

Remove the seat and fuel tank.
Remove the carburetor top from the carburetor.

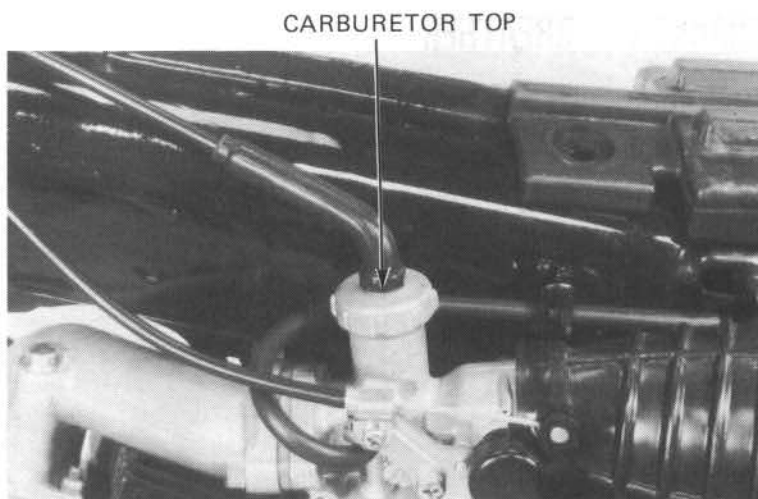

Remove the throttle cable from the throttle valve while depressing the throttle valve spring.

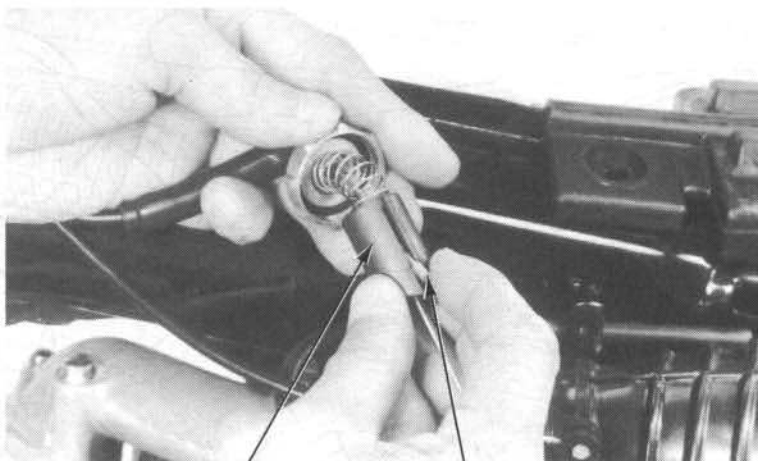

THROTTLE VALVE THROTTLE CABLE

Remove the needle clip retainer.
Remove the jet needle and needle clip.

Inspect the throttle valve and jet needle surface for dirt, scratches or wear.

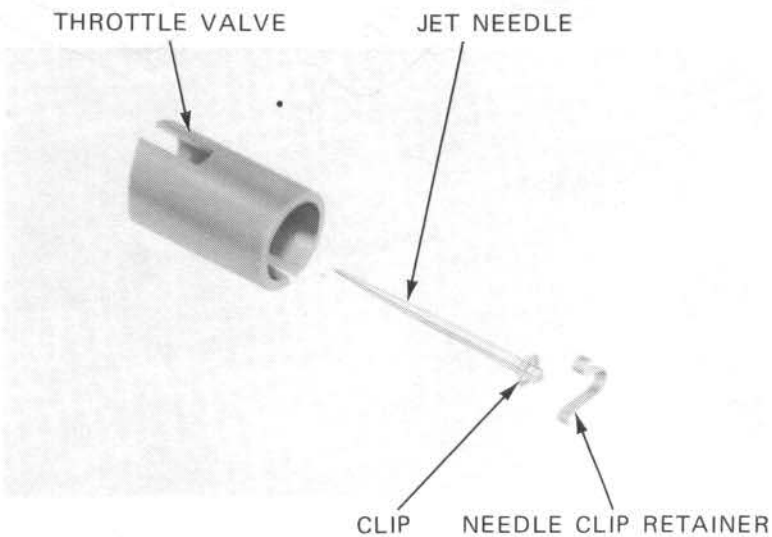

CARBURETOR REMOVAL

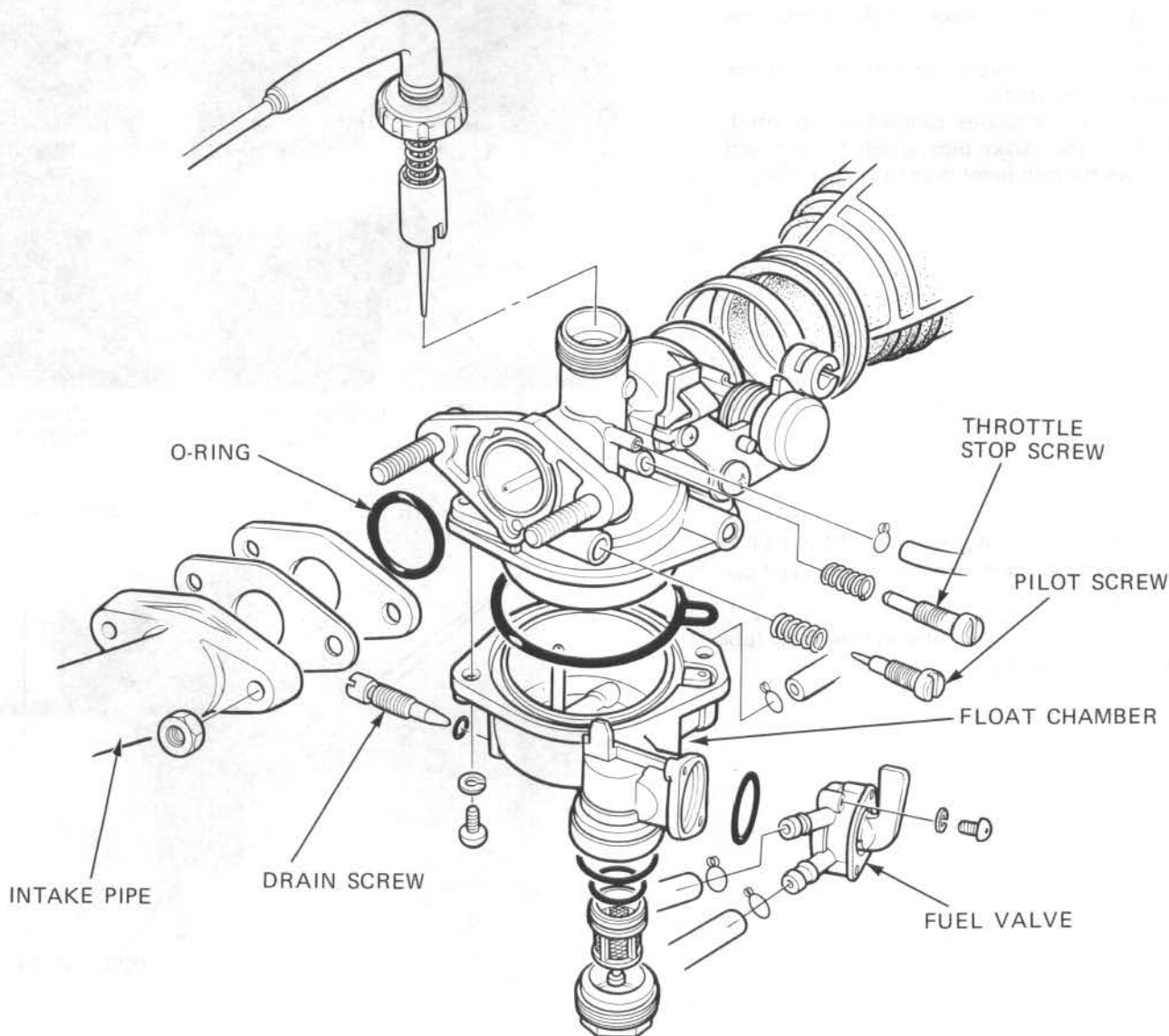

Turn the fuel valve OFF and remove the fuel valve from the valve body by removing the two screws.

Remove the carburetor top (Page 4-6).

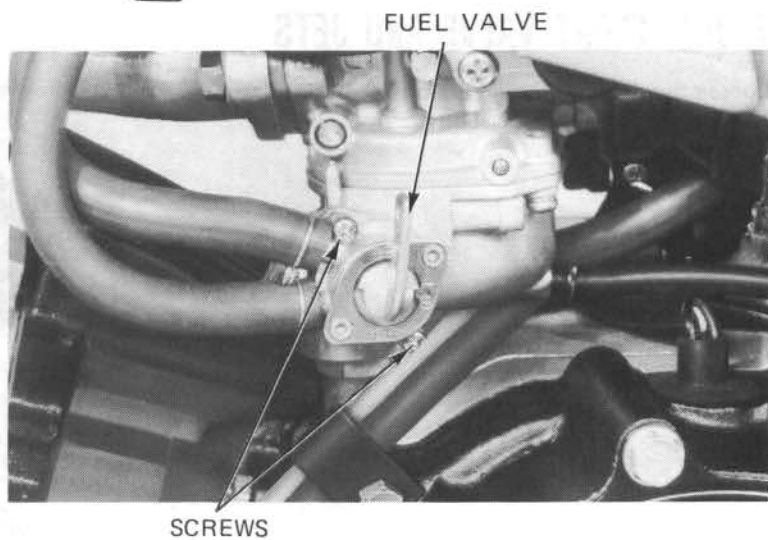

FUEL SYSTEM

Loosen the choke cable clamp screw and disconnect the choke cable from the carburetor.

Remove the carburetor air vent tube from the clamp on the frame.

Loosen the air cleaner connecting tube band. Remove the intake pipe attaching bolts and remove the carburetor with the intake pipe.

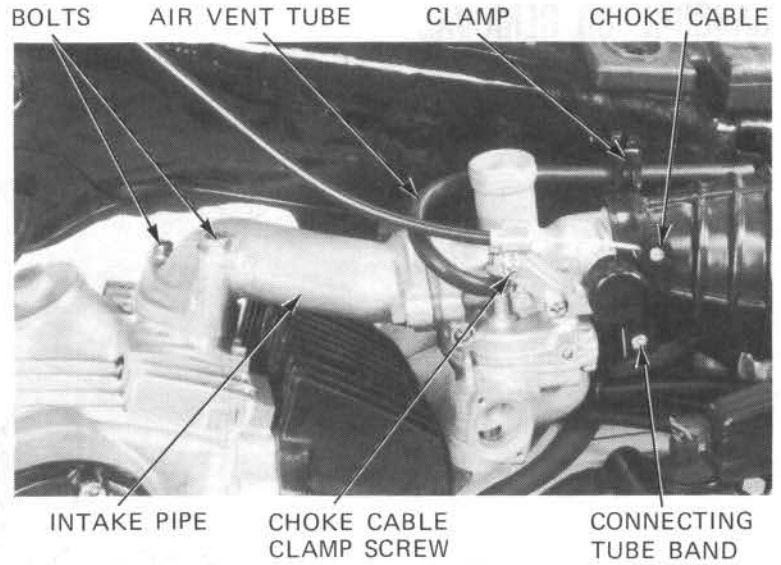

Remove the nuts attaching the intake pipe to the carburetor and remove the pipe and carburetor insulator.

Remove the air vent tube and overflow tube from the carburetor.

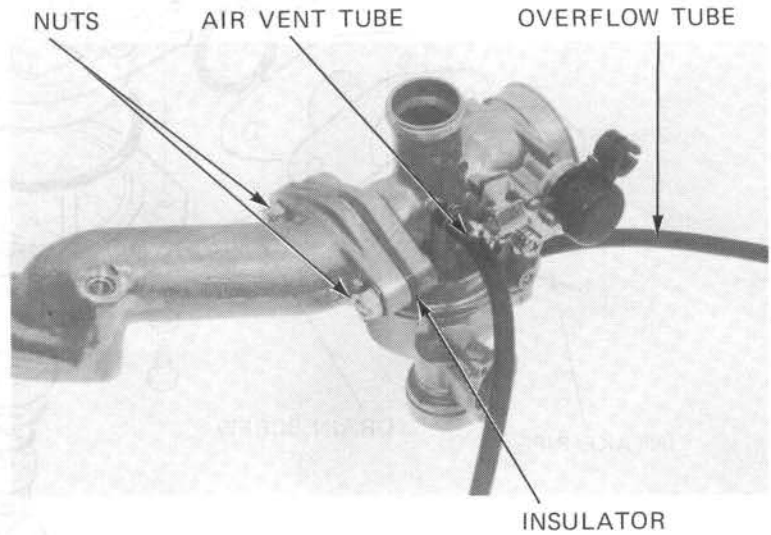

FLOAT, FLOAT VALVE AND JETS

Loosen the drain screw and drain the gasoline. Remove the float chamber body.

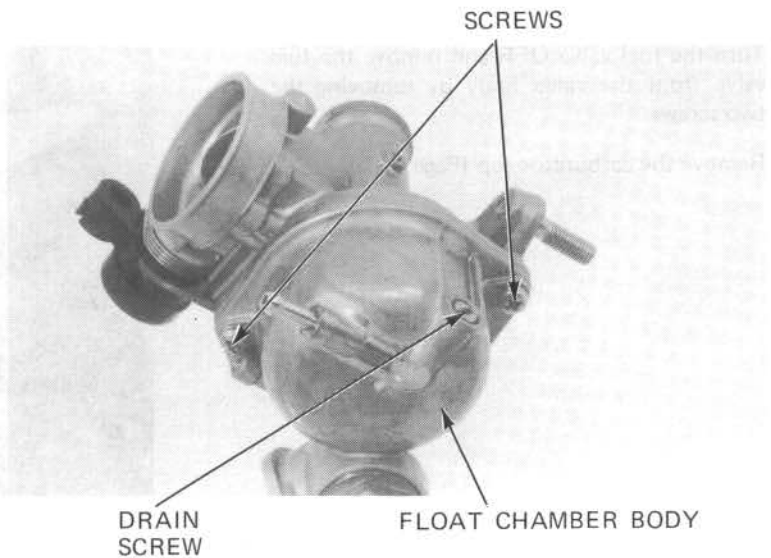

Remove the float arm pin with pliers.
Remove the float and float valve.

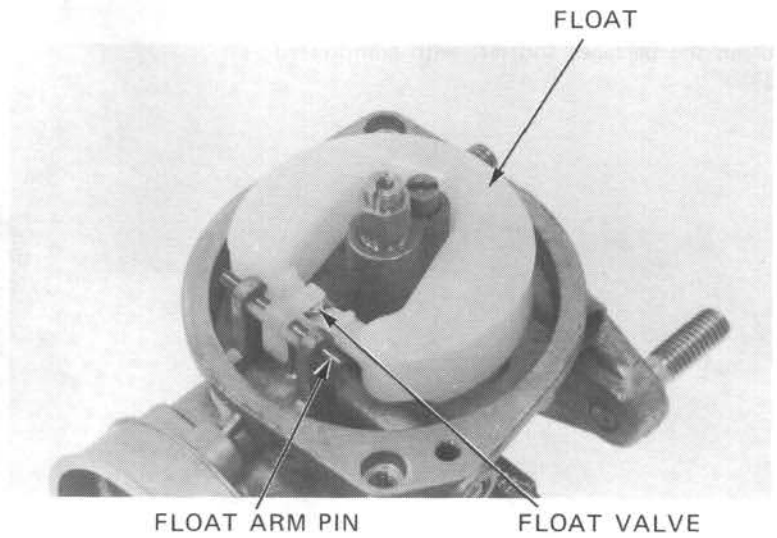

Inspect the float valve and seat for wear or damage.

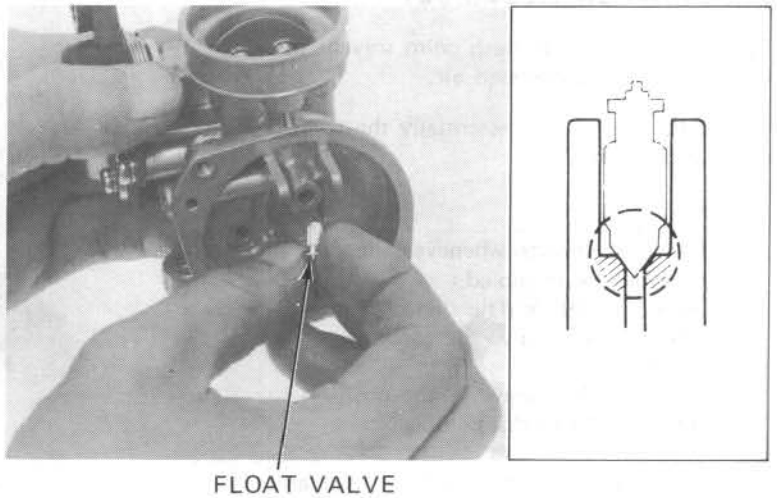

Remove the slow jet.
Remove the main jet, needle jet holder and needle jet.

Before removing the pilot screw, record the number of turns until the screw seats lightly.

Then remove the screw.
Blow open all jets and body openings with compressed air.

Inspect the pilot screw, needle jet, needle jet holder and main jet.
Check each part for wear or damage.

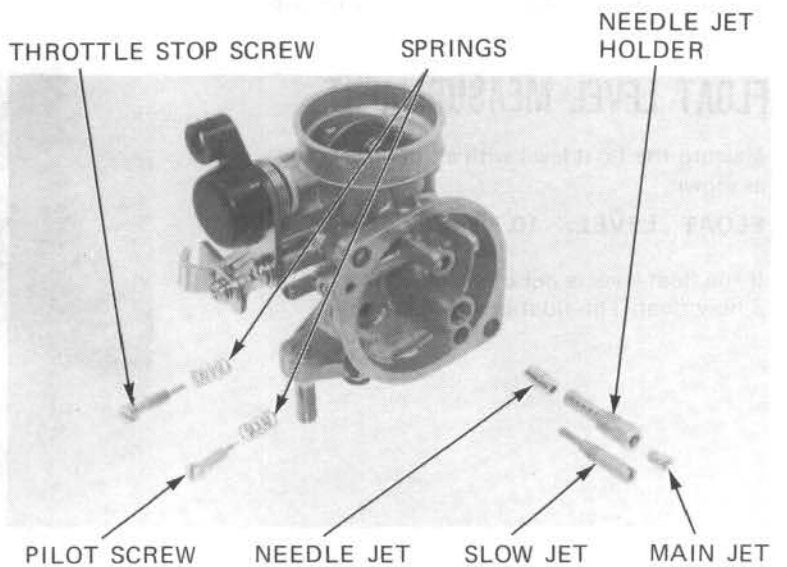

Clean the passages and jets with compressed air.

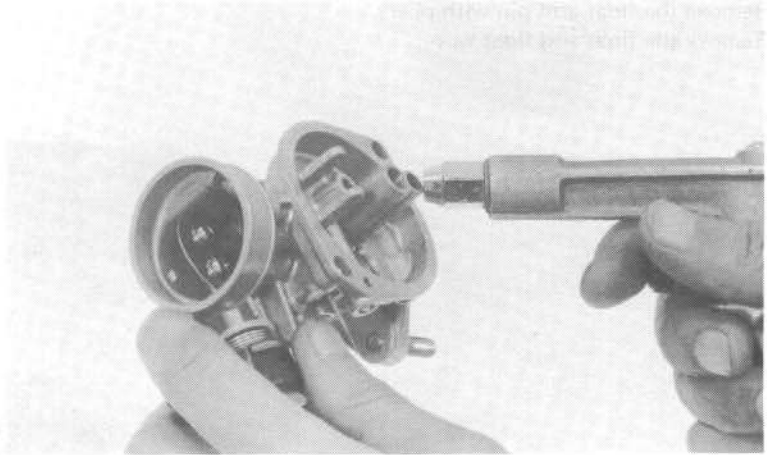

CARBURETOR ASSEMBLY

Clean all parts in high flash point solvent and blow dry with compressed air.

Carburetor assembly is essentially the reverse order of disassembly.

NOTE

- Use new O-rings whenever the carburetor is reassembled.
- Handle all jets and needles with care. They can easily be scored or scratched.
- Set the pilot screw at the position recorded during disassembly.

After assembly, turn on the fuel valve and check for leaks.

Adjust idle speed (Page 3-7) and throttle grip free play (Page 3-8).

FLOAT LEVEL MEASUREMENT

Measure the float level with a float level gauge as shown.

FLOAT LEVEL: 10.7 mm (0.43 in)

If the float level is out of specification, install a new float. The float is not adjustable.

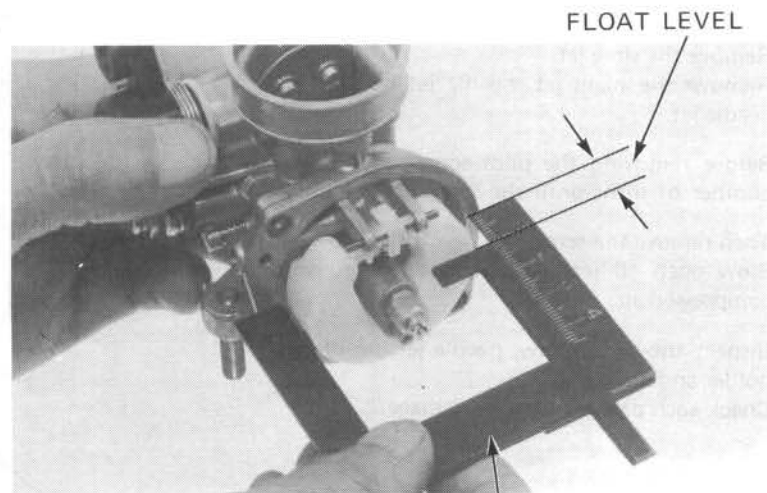
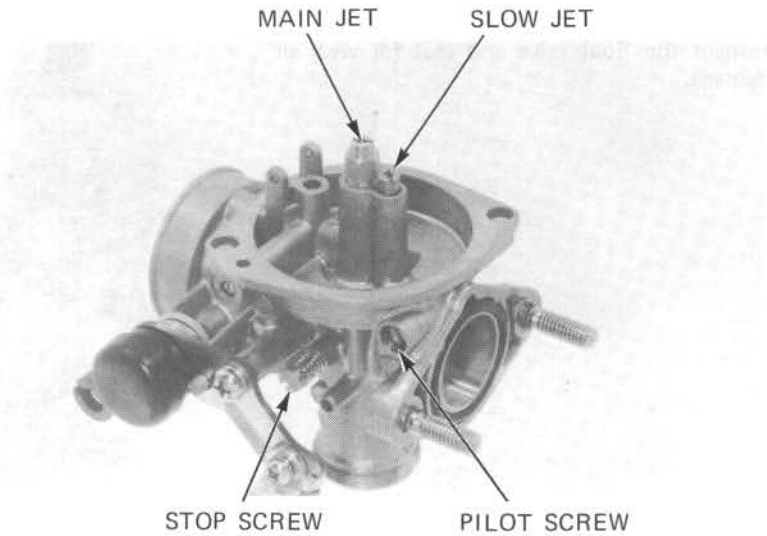

FLOAT LEVEL GAUGE
07401-0010000

CARBURETOR INSTALLATION

Attach the intake pipe to the carburetor.

TORQUE: 6–9 N·m (0.6–0.9 kg-m,
4.5–7 ft-lb)

Install the carburetor in the reverse order of removal.

NOTE

After installing the carburetor, perform the following adjustments:

- Throttle lever free play (Page 3–8).
- Carburetor pilot screw adjustment (Page 4–12), if the carburetor was overhauled or cleaned.

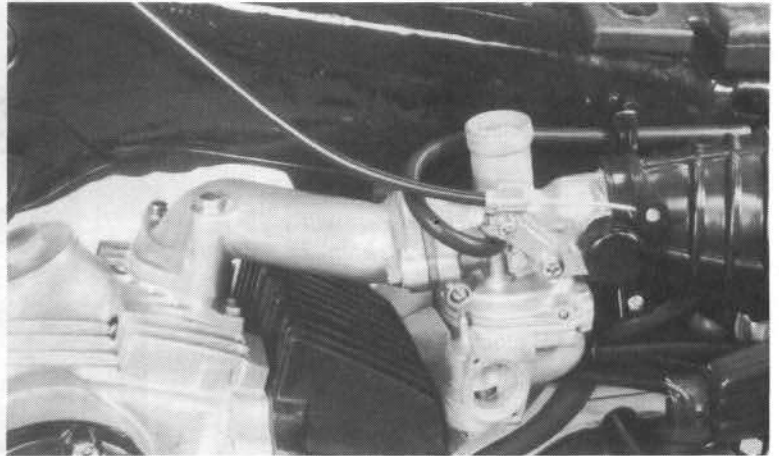

THROTTLE VALVE ASSEMBLY

Install the needle clip on the jet needle.

STANDARD SETTING: 2nd groove

Install the jet needle into the throttle valve and secure it with the needle clip retainer.

Install the throttle cable, spring, and throttle valve.

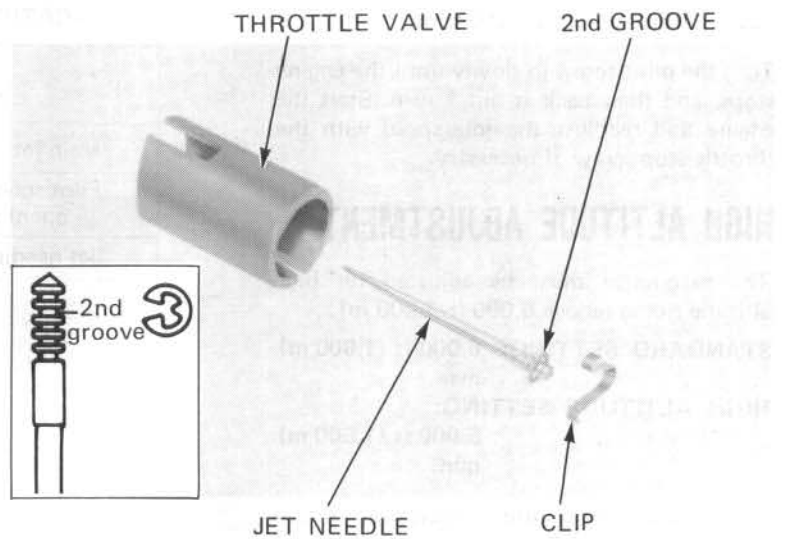

Align the throttle valve groove with the throttle stop screw and install the carburetor top onto the carburetor. Adjust throttle lever free play (Page 3–8).

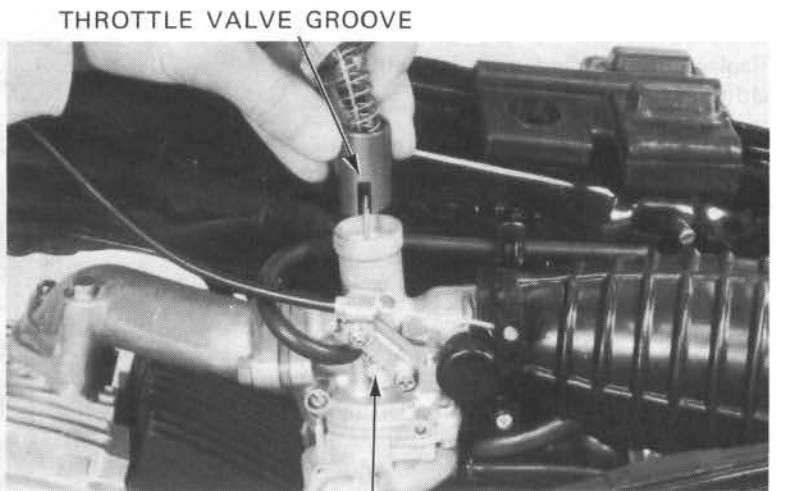

THROTTLE STOP SCREW

PILOT SCREW ADJUSTMENT

NOTE

The pilot screw is factory pre-set. Adjustment is not necessary unless the carburetor is overhauled or cleaned.

CAUTION

Damage to the pilot screw seat will occur if the pilot screw is tightened against the seat.

Turn the pilot screw clockwise until it seats lightly and back it out 1 3/8 turns. This is an initial setting prior to the final pilot screw adjustment.

Warm the engine up to operating temperature. Stop the engine and connect a tachometer. Start the engine and adjust the idle speed with the throttle stop screw.

IDLE SPEED: 1,700 ± 100 rpm

Turn the pilot screw in slowly until the engine stops, and then back it out 1 turn. Start the engine and readjust the idle speed with the throttle stop screw, if necessary.

HIGH ALTITUDE ADJUSTMENT

The carburetor must be adjusted for high altitude riding (above 6,000 ft/1,800 m).

STANDARD SETTING: 6,000 ft (1,800 m) max.

HIGH ALTITUDE SETTING: 5,000 ft (1,500 m) min.

High altitude carburetor adjustment is performed as follows:

Remove and disassemble the carburetor (Page 4-7 and 4-8).

Replace the standard main jet with the high altitude type (#88).

Assemble and install the carburetor. Start the engine and adjust the idle speed at high altitude to ensure proper high altitude operation.

CAUTION

Sustained operation below 5,000 feet (1,500 m) with the high altitude settings may cause engine overheating and engine damage. Install the #92 main jet, when riding below 5,000 feet (1,500 m).

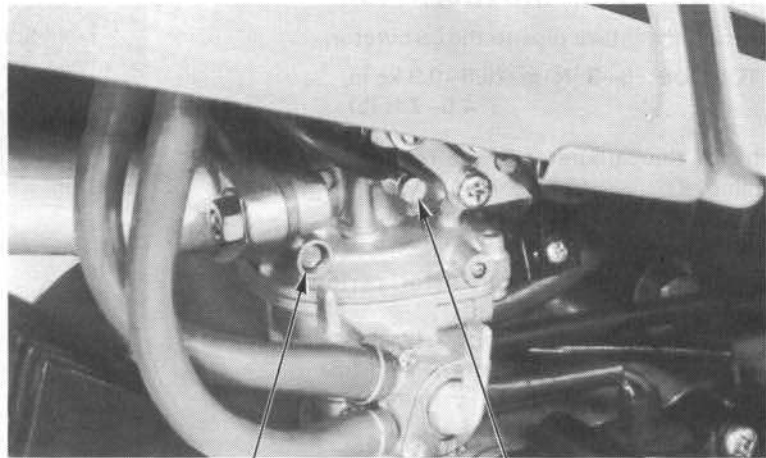

PILOT SCREW

THROTTLE STOP SCREW

SPECIFICATIONS

	Below 6,000ft (1,800m)	Above 5,000ft (1,500m)
Main jet	No. 92	No. 88
Pilot screw opening	Factory preset	Screw in 1/2 turn
Jet needle	2nd groove	2nd groove



MAIN JET

PILOT SCREW

MEMO

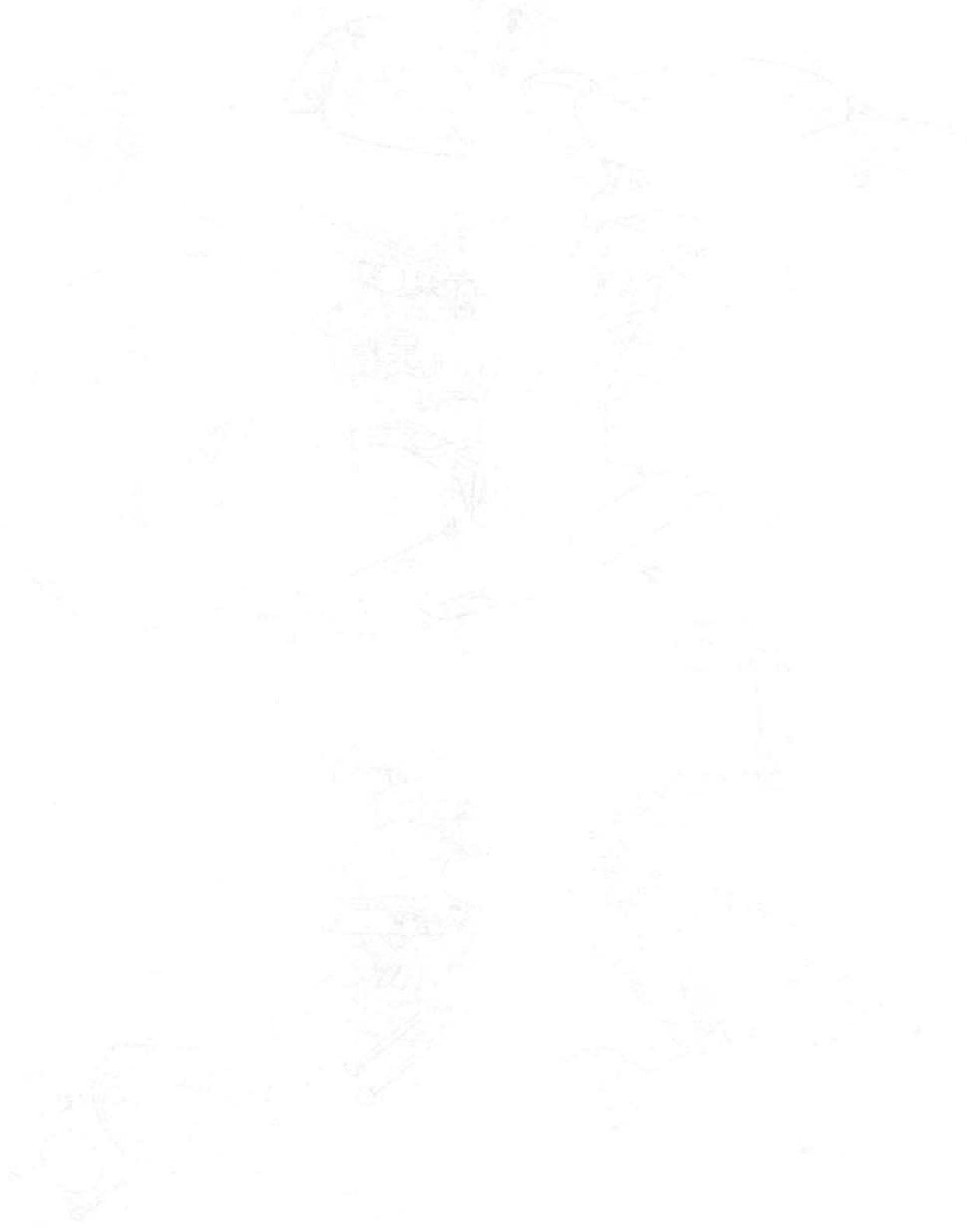

ENGINE REMOVAL/ INSTALLATION

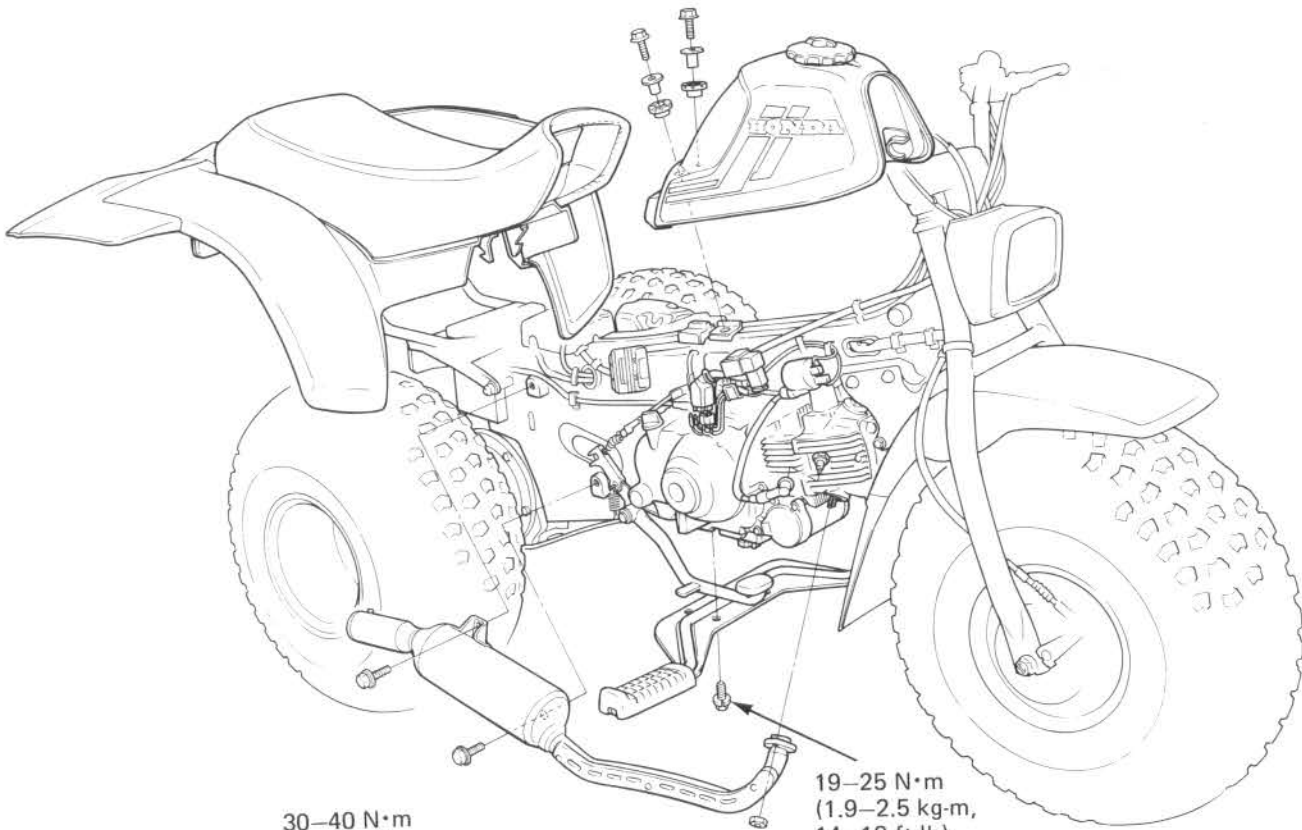

30–40 N·m
(3.0–4.0 kg·m,
22–29 ft·lb)

19–25 N·m
(1.9–2.5 kg·m,
14–18 ft·lb)

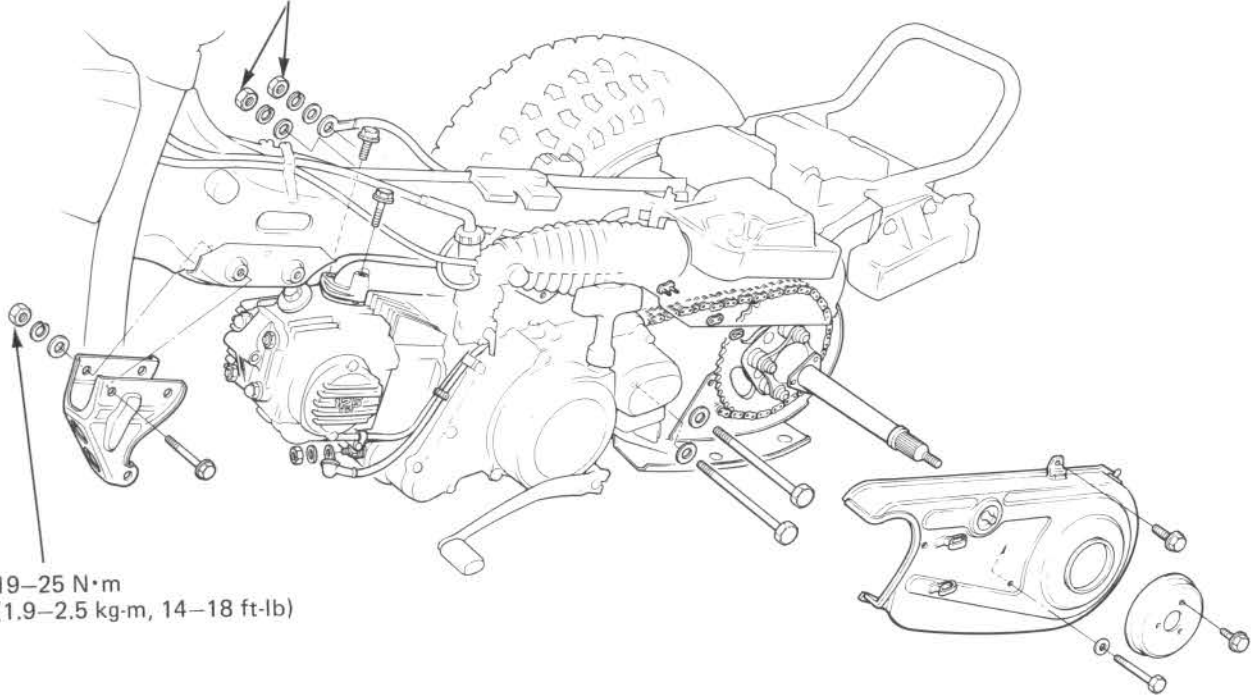

19–25 N·m
(1.9–2.5 kg·m, 14–18 ft·lb)

5. ENGINE REMOVAL/ INSTALLATION

SERVICE INFORMATION	5-1
ENGINE REMOVAL	5-2
ENGINE INSTALLATION	5-4

SERVICE INFORMATION

GENERAL

- The rear wheel, skid plate, drive chain cover and drive chain (Section 13) must be removed before the engine can be removed from the frame.
- The only operation requiring engine removal is transmission and crankshaft service (Section 11).

SPECIFICATIONS

Engine oil capacity	1.2 lit (1.27 US qt, 1.06 Imp qt) after disassembly 1.1 lit (1.16 US qt, 0.97 Imp qt) after draining
---------------------	---

TORQUE VALUES

Foot peg bolt	19–25 N•m (1.9–2.5 kg-m, 14–18 ft-lb)
Rear axle nut	60–80 N•m (6.0–8.0 kg-m, 43–58 ft-lb)
Change pedal bolt	10–14 N•m (1.0–1.4 kg-m, 7–10 ft-lb)
Engine hanger bolt 8 mm	19–25 N•m (1.9–2.5 kg-m, 14–18 ft-lb)
10 mm	30–40 N•m (3.0–4.0 kg-m, 22–29 ft-lb)

ENGINE REMOVAL

Remove the seat and fuel tank.
Remove the left rear wheel (Page 13-3).

Remove the skid plate, sealed cover, chain cover and drive chain (Page 13-4).

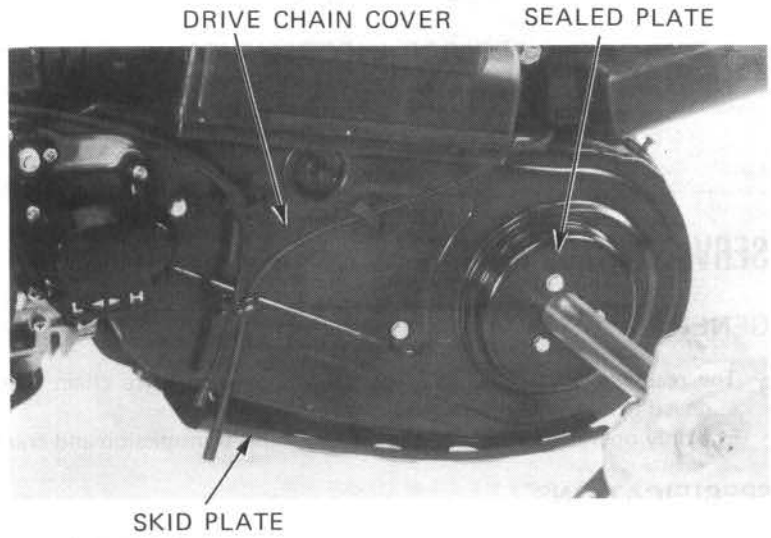

Remove the four bolts mounting the foot peg and the foot peg.

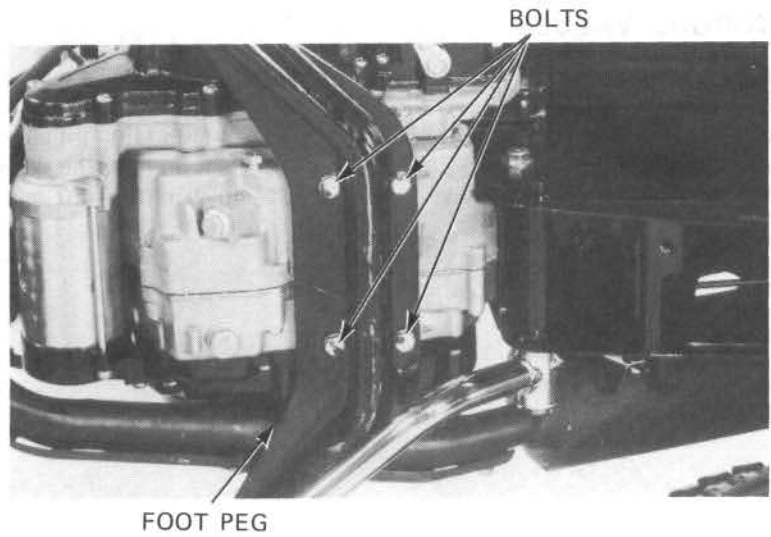

Disconnect the starter motor cable from the motor.

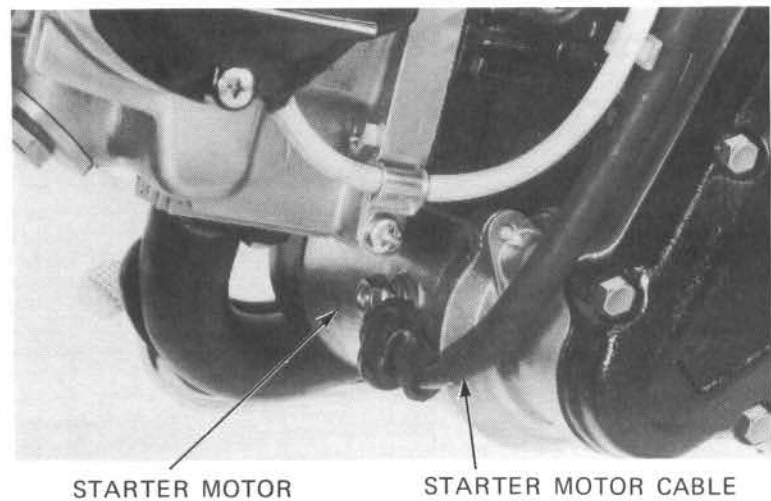

Remove the two bolts attaching the intake pipe to the cylinder head.

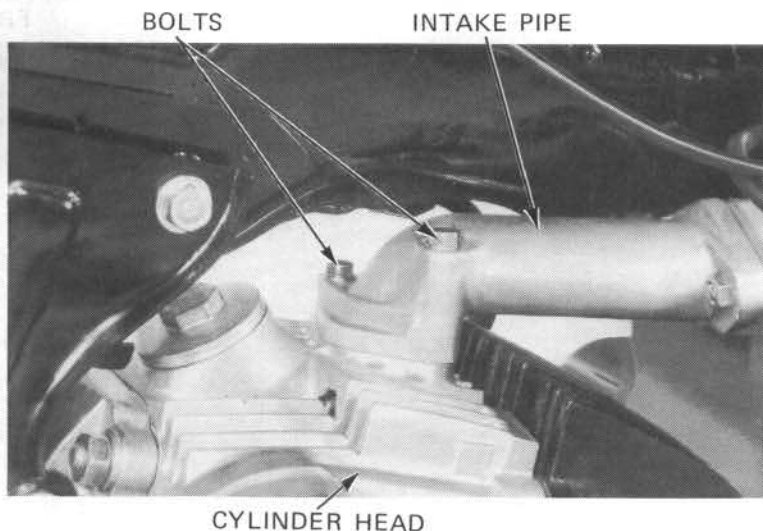

Remove the spark plug cap.
Remove the exhaust pipe (Page 14-2).

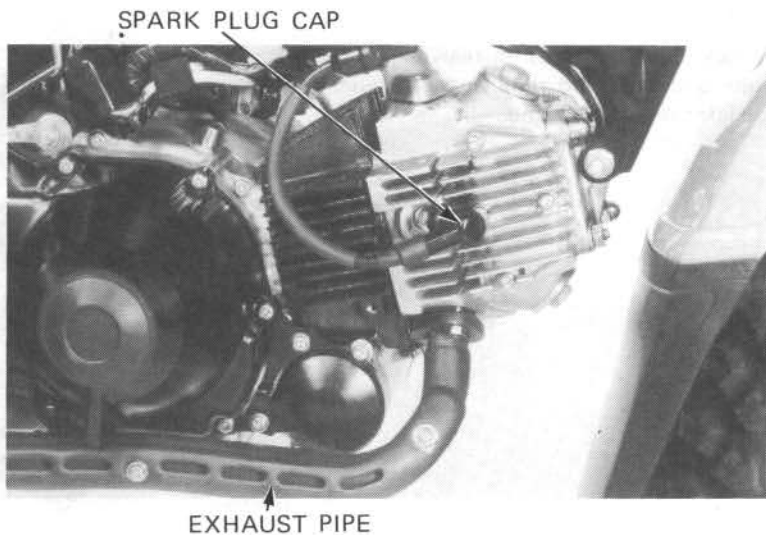

Remove the wire harness from the clamp on the frame, slide the connector cover and disconnect the alternator, pulse generator and neutral switch wire couplers/connectors.

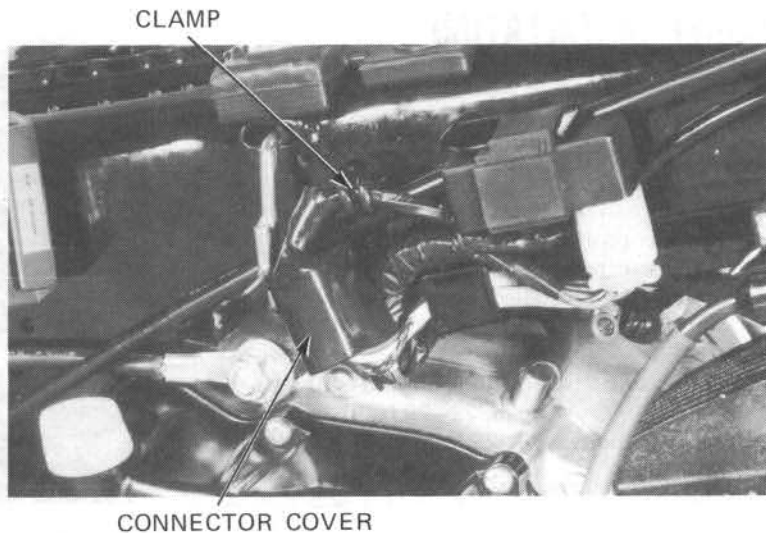

ENGINE REMOVAL/INSTALLATION

Remove the three 8 mm front engine hanger bolts, nuts and bracket.

FRONT ENGINE HANGER BRACKET

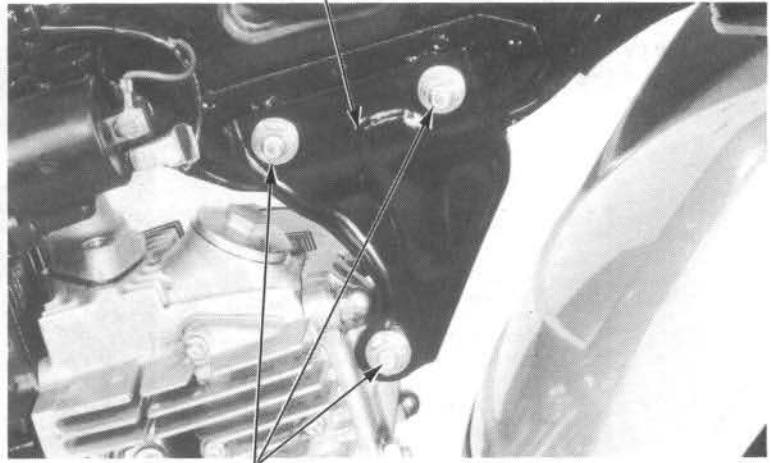

8 mm BOLTS/NUTS

Remove the two 10 mm rear engine hanger bolts and nuts and remove the engine from the left side of the frame.

10 mm REAR ENGINE HANGER BOLTS/NUTS

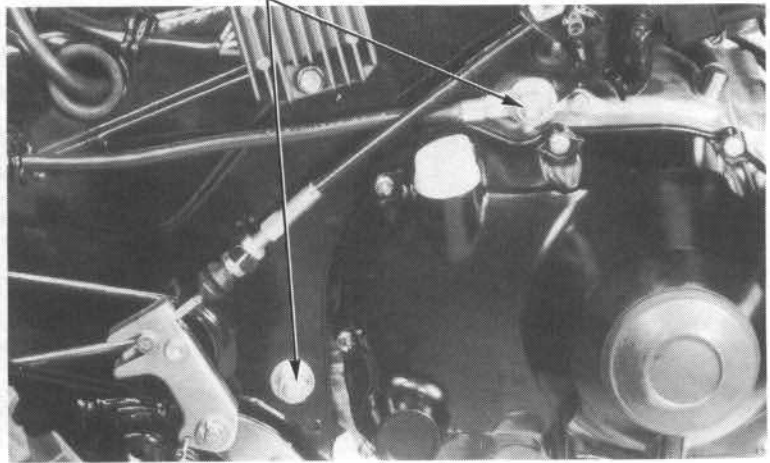

ENGINE INSTALLATION

Install the engine in the reverse order of removal.

NOTE

- Be sure to use the correct bolts in the proper position.
- Tighten the engine hanger bolts after they are all installed loosely.

TORQUES:

10mm hanger bolts: 30–40 N·m (3.0–4.0 kg-m, 22–29 ft-lb)

8 mm hanger bolts: 19–25 N·m (1.9–2.5 kg-m, 14–18 ft-lb)

Foot peg bolts: 19–25 N·m (1.9–2.5 kg-m, 14–18 ft-lb)

BATTERY GROUND CABLE

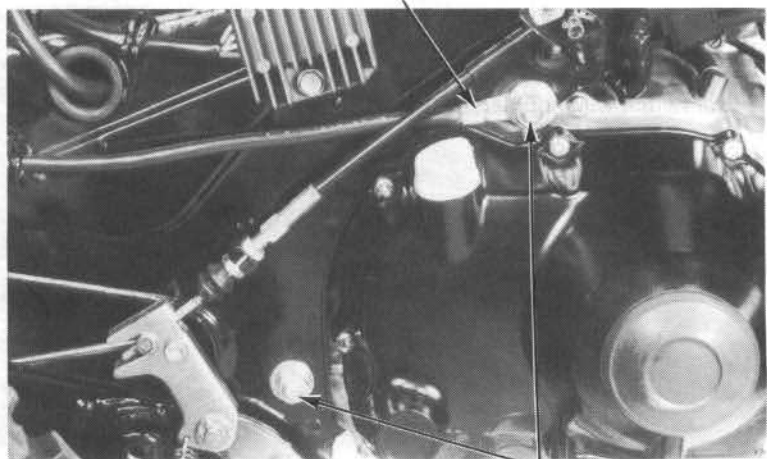

10 mm ENGINE HANGER BOLTS

NOTE

After installing the engine, perform the following inspections and adjustments:

- Engine oil level (Page 2-2).
- Throttle lever free play (Page 3-8).
- Drive chain free play (Page 3-11).
- Check that exhaust gas is not leaking past the exhaust pipe connection.
- Check the electrical equipment performance.

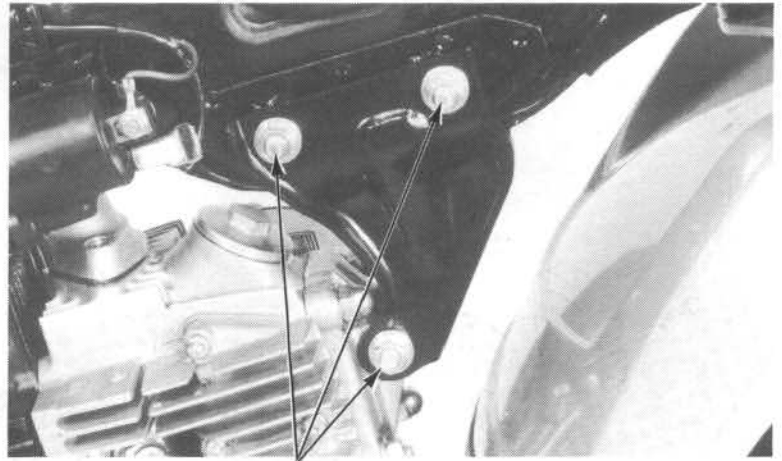

8 mm HANGER BOLTS

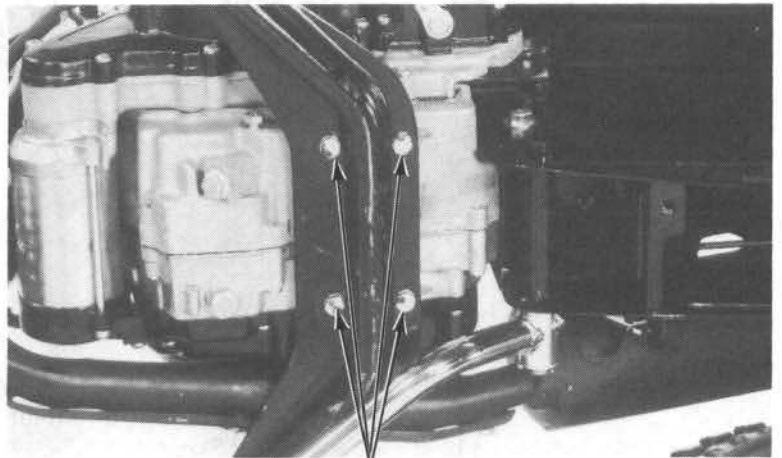

FOOT PEG BOLTS

CYLINDER HEAD/VALVES

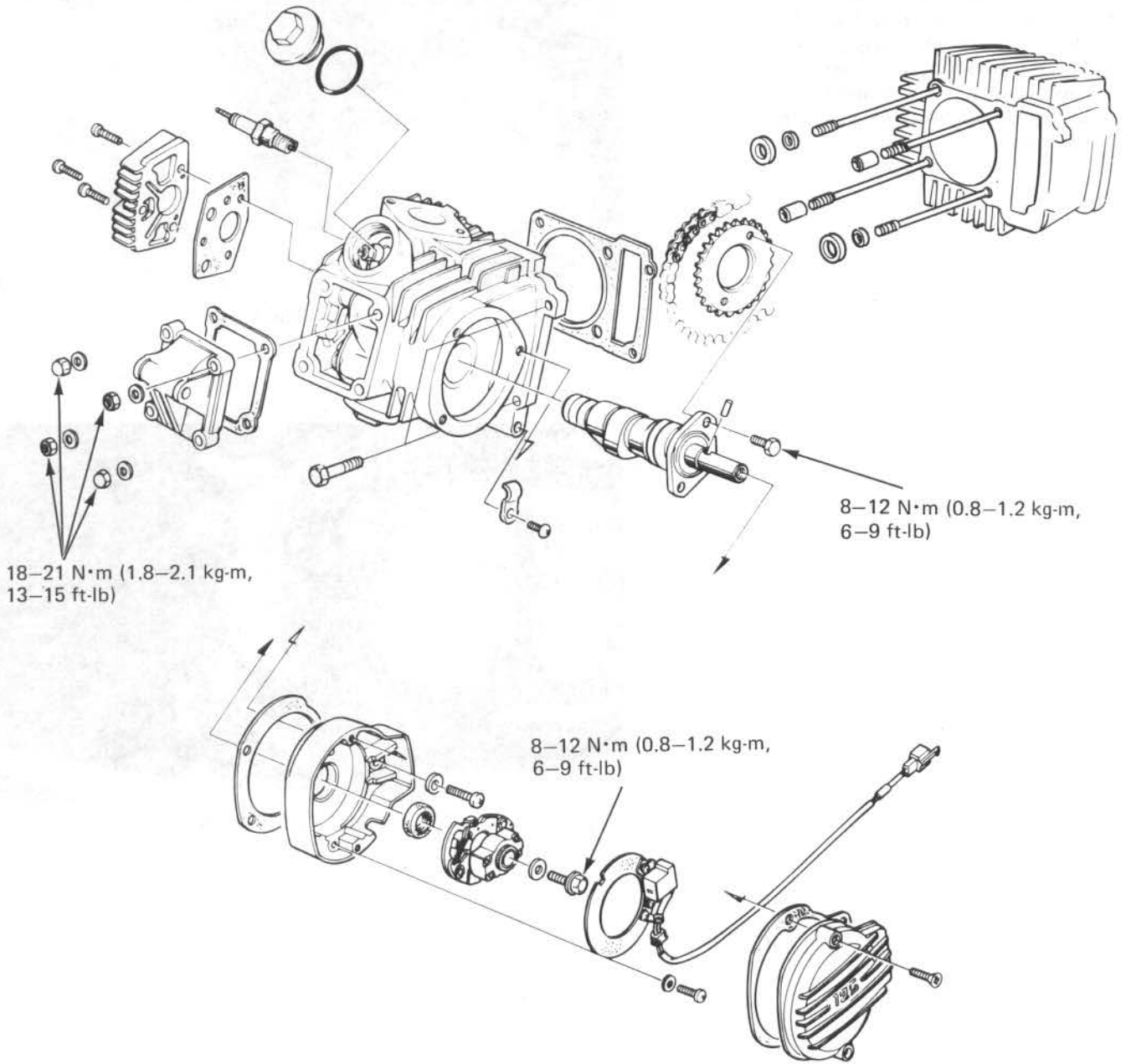

6. CYLINDER HEAD/VALVES

SERVICE INFORMATION	6-1	VALVE SEAT INSPECTION/ REFACING	6-11
TROUBLESHOOTING	6-2	CYLINDER HEAD ASSEMBLY	6-13
CYLINDER HEAD REMOVAL	6-3	CYLINDER HEAD INSTALLATION	6-15
CYLINDER HEAD DISASSEMBLY	6-8		

SERVICE INFORMATION

GENERAL

- This section covers cylinder head, valves, camshaft and rocker arm maintenance.
- Camshaft lubrication oil is fed to the cylinder head through an oil control orifice in the crankcase. Be sure that this orifice is not clogged and that new O-rings and dowel pins are in place before installing the cylinder head.

SPECIFICATIONS

ITEM		STANDARD		SERVICE LIMIT
Cylinder compression		12.5 ± 1.5 kg/cm ² (177.8 ± 21.3 l psi)		9.0 kg/cm ² (128.0 psi)
Camshaft O. D.	R	19.934–17.945 mm	(0.7060–0.7065 in)	17.90 mm (0.705 in)
	L	25.932–25.945 mm	(1.0210–1.0215 in)	25.90 mm (1.020 in)
Cam lobe height	EX/IN	24.118–24.278 mm	(0.9495–0.9558 in)	23.8 mm (0.94 in)
Rocker arm I. D.		10.000–10.015 mm	(0.3937–0.3943 in)	10.10 mm (0.398 in)
Rocker arm shaft O. D.		9.972–9.987 mm	(0.3926–0.3932 in)	9.92 mm (0.391 in)
Rocker arm shaft clearance		—————		0.08 mm (0.003 in)
Cylinder warpage		—————		0.10 mm (0.004 in)
Valve spring free length	IN	31.1 mm	(1.22 in)	29.9 mm (1.18 in)
	OUT	35.0 mm	(1.38 in)	33.7 mm (1.32 in)
Valve stem O. D.	IN	5.450–5.465 mm	(0.2146–0.2152 in)	5.435 mm (0.2139 in)
	EX	5.430–5.445 mm	(0.2138–0.2144 in)	5.415 mm (0.2132 in)
Valve guide I. D.	EX/IN	5.475–5.485 mm	(0.2157–0.2161 in)	5.525 mm (0.2175 in)
Stem-to-guide clearance	IN	0.010–0.035 mm	(0.0004–0.0014 in)	0.08 mm (0.003 in)
	EX	0.030–0.055 mm	(0.0012–0.0022 in)	0.10 mm (0.004 in)
Valve face width	IN/EX	1.2–1.5 mm	(0.05–0.06 in)	1.8 mm (0.07 in)
Valve seat width	IN/EX	1.0 mm	(0.04 in)	1.6 mm (0.06 in)
End hole I. D.	R	18.000–18.018 mm	(0.7087–0.7094 in)	18.05 mm (0.711 in)
	L	26.000–26.020 mm	(1.0236–1.0244 in)	26.05 mm (1.026 in)
Camshaft-to-end hole clearance	R	—————		0.12 mm (0.005 in)
	L	—————		0.16 mm (0.006 in)

TORQUE VALUES

Cylinder head	18–21 N·m (1.8–2.1 kg-m, 13–15 ft-lb)
Cam sprocket	8–12 N·m (0.8–1.2 kg-m, 6–9 ft-lb)
Pulse rotor bolt	8–12 N·m (0.8–1.2 kg-m, 6–9 ft-lb)
Front engine bracket	19–25 N·m (1.9–2.5 kg-m, 14–18 ft-lb)

TOOLS

Special

Valve Guide Reamer	07984–0980000
Valve Guide Driver	07942–1180100

Common

Valve Spring Compressor	07757–0010000 (or 07957–3290001)
Valve Guide driver	07742–0010100 (or 07942–3290100)
Honda Valve Seat Cutter	
Cutter Holder	07781–0010101
Cutter	07780–0010100, 07780–0012000 } (Commercially available in USA)
	07780–0010200, 07780–0012100 }
	07780–0014000 }

TROUBLESHOOTING

Engine top-end problems usually affect engine performance. These problems can be diagnosed by a compression test, or by tracing engine noises to the top end with a sounding rod or stethoscope.

Low compression

1. Valve
 - Incorrect valve adjustment
 - Burned or bent valve
 - Incorrect valve timing
 - Weak valve spring
2. Cylinder head
 - Leaking or damaged head gasket
 - Warped or cracked cylinder head
3. Cylinder and piston (Section 7)
4. Faulty decompression lever

High compression

1. Excessive carbon build-up on piston crown or on combustion chamber

Excessive noise

1. Incorrect valve adjustment
2. Sticking valve or broken valve spring
3. Damaged or worn rocker arm or camshaft
4. Worn or damaged cam chain
5. Worn or damaged cam chain tensioner
6. Worn cam sprocket teeth

Poor idling

1. Compression too low
2. Faulty decompression lever

Hard starting

1. Faulty decompression lever

CYLINDER HEAD REMOVAL

Remove the pulse cover.



PULSE COVER

Disconnect the pulse generator wire from the wire harness.

Remove the bolt attaching the pulse generator wire clamp to the cylinder head.

Remove the pulse generator screws, and remove the pulse generator.

Remove the pulse rotor bolt and remove the rotor.

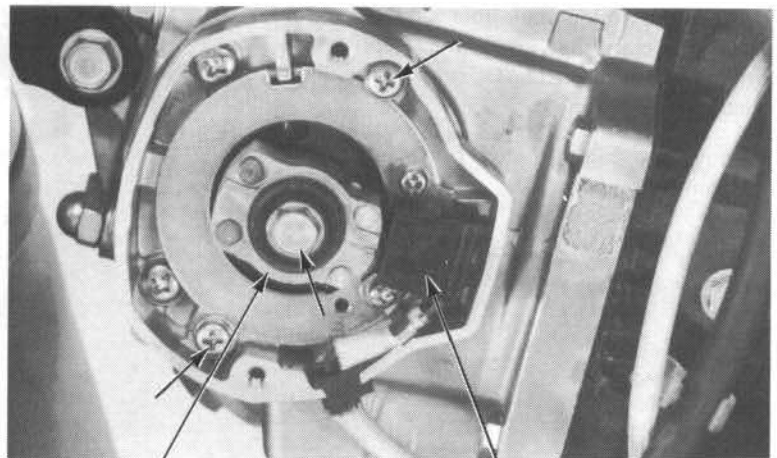

PULSE ROTOR

PULSE GENERATOR

Remove the dowel pin, then remove the pulse base.

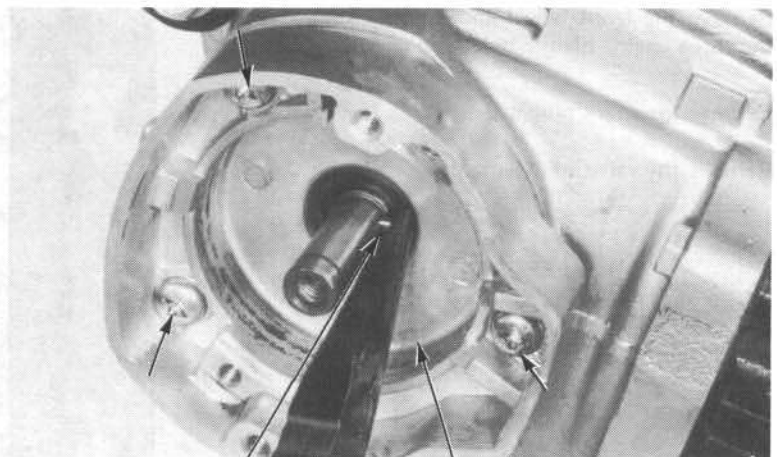

DOWEL PIN

PULSE BASE

CYLINDER HEAD/VALVES

'84:
Loosen the cam chain lock nut and tensioner adjusting screw.
After '84:
Remove the tensioner bolt, sealing washer, push rod, and tensioner spring.

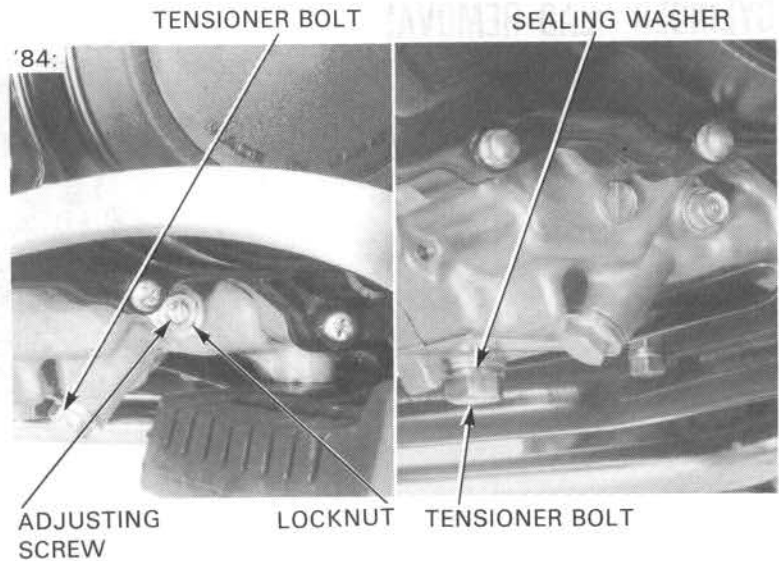

Remove the timing mark hole cap.
Turn the crankshaft with the recoil starter until the cam sprocket "O" mark and cylinder head index mark align.

Remove the cam sprocket bolts and remove the camshaft.

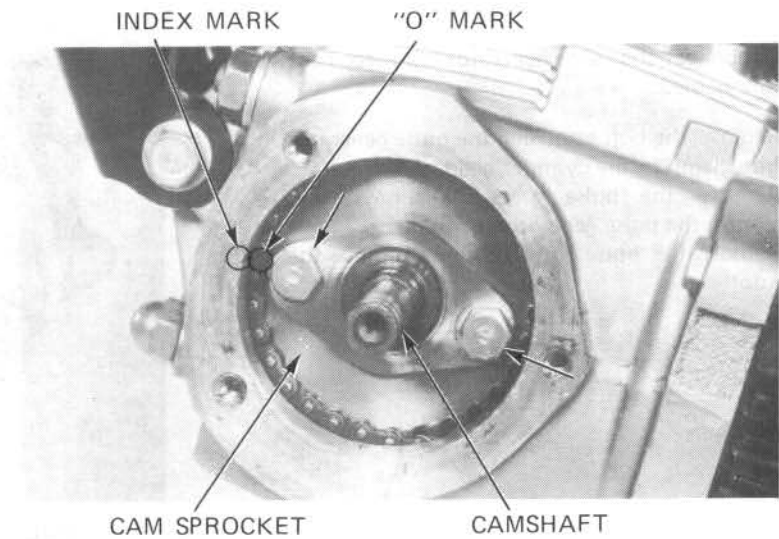

Remove the front wheel and fender. Remove the three engine hanger bolts and bracket.

Remove the spark plug cap.

Remove the valve adjuster caps.

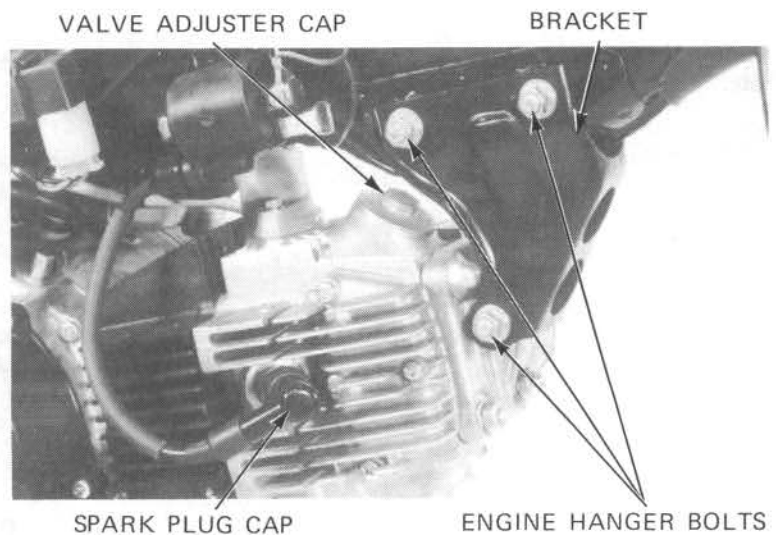

Remove the two intake pipe bolts.
Remove the two cylinder head base bolts.

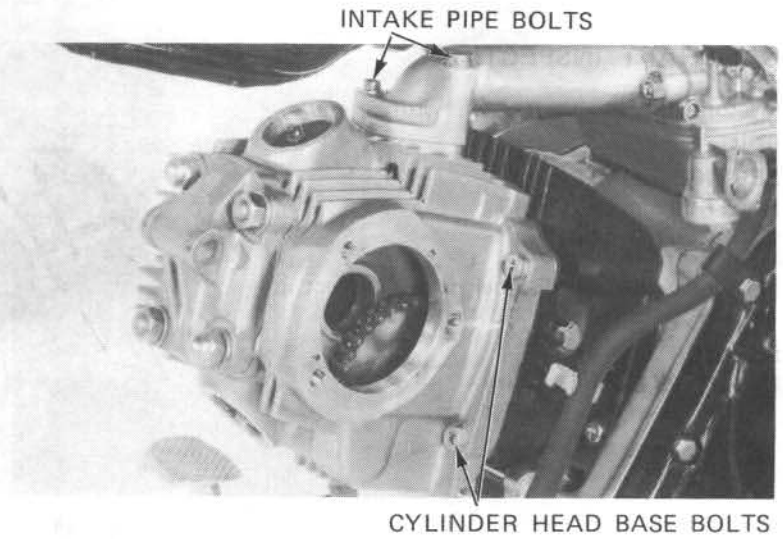

Loosen the cylinder head nuts in a criss cross pattern in 2 – 3 steps and remove them.
Remove the cylinder head.

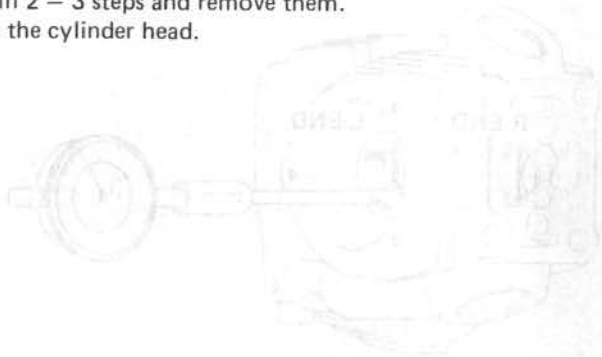

CYLINDER HEAD NUTS

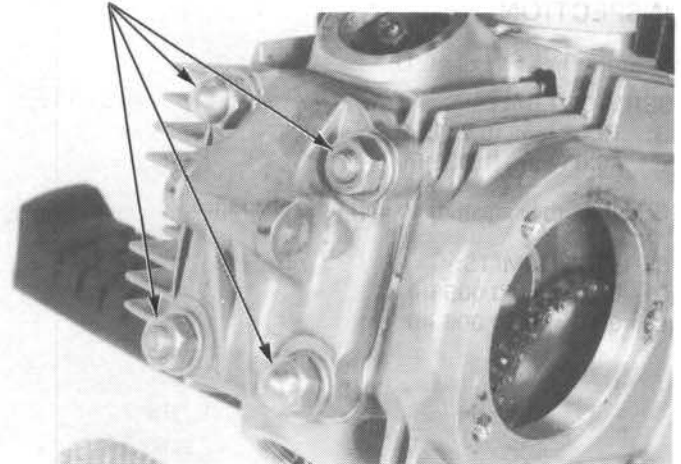

Remove the head gasket, O-rings and dowel pins.

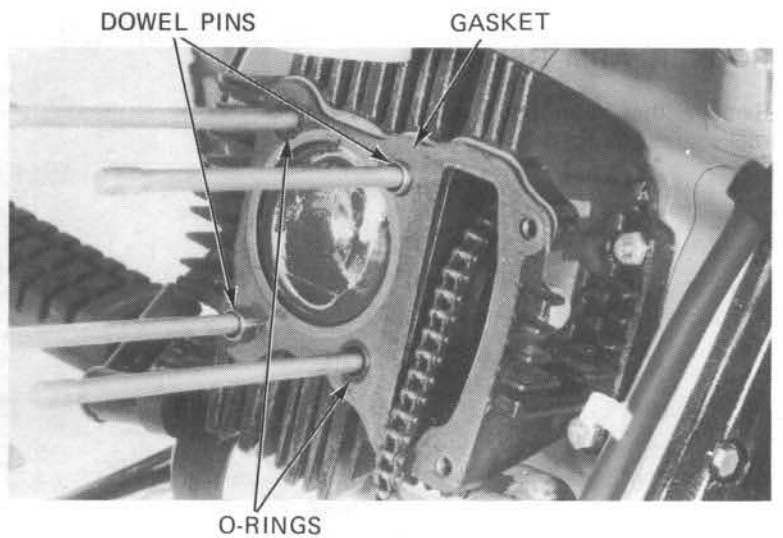

CAMSHAFT INSPECTION

Measure the camshaft O.D. with a micrometer.

SERVICE LIMITS:
R: 17.90 mm (0.705 in)
L: 25.90 mm (1.020 in)

Measure each cam lobe height and inspect it for wear or damage.

SERVICE LIMIT:
IN/EX: 23.8 mm (0.94 in)

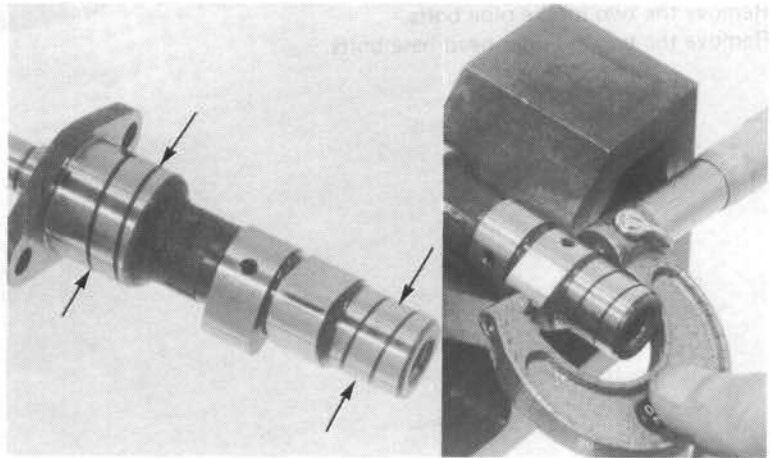

CAMSHAFT-TO-END HOLE INSPECTION

Measure the end hole I. D.

SERVICE LIMITS:
R: 18.05 mm (0.711 in)
L: 26.05 mm (1.026 in)

Calculate the camshaft to end hole clearance.

SERVICE LIMITS:
R: 0.12 mm (0.005 in)
L: 0.16 mm (0.006 in)

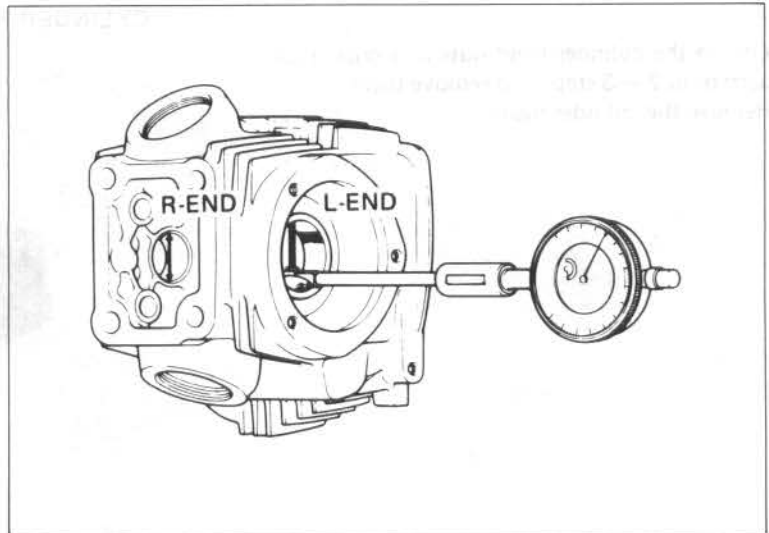

ROCKER ARM REMOVAL

Remove the four screws and remove the rocker arm side cover and gasket.

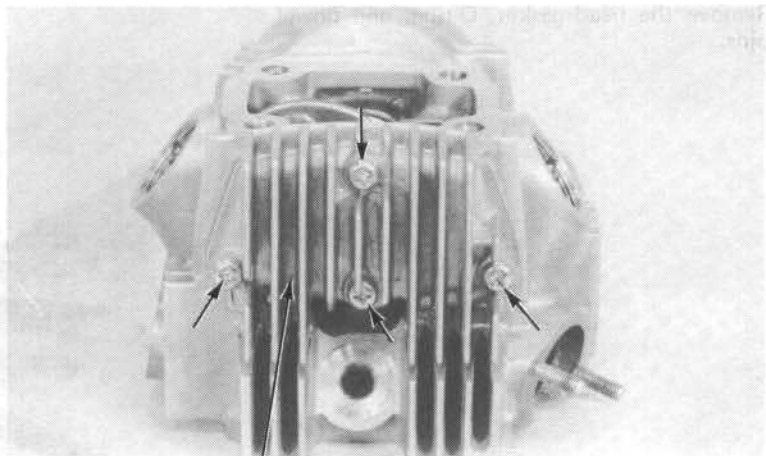

ROCKER ARM SIDE COVER

Lightly tap around the surface of the rocker arm, then remove the rocker arm shafts and rocker arms.

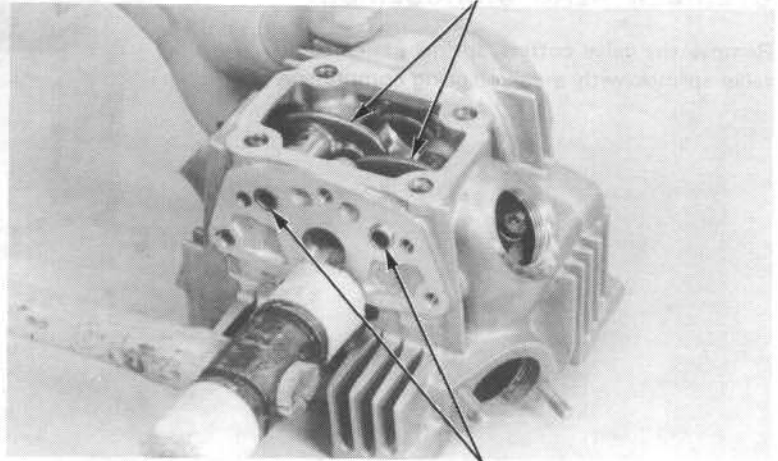

ROCKER ARM SHAFTS

ROCKER ARM INSPECTION

Inspect the rocker arms for damage, wear or clogged oil holes.

NOTE

If any rocker arms require servicing or replacement, inspect the cam lobes for scoring, chipping or flat spots.

Measure the I. D. of each rocker arm.

SERVICE LIMIT: 10.10 mm (0.398 in)

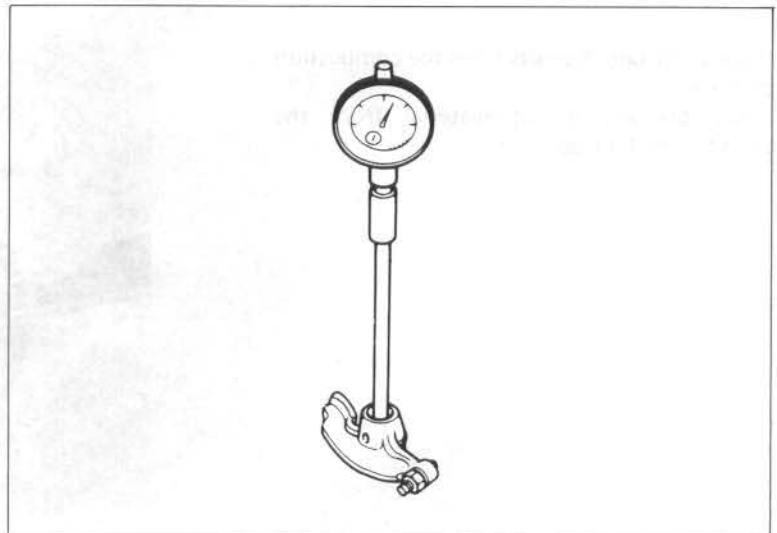

ROCKER ARM SHAFT INSPECTION

Inspect the rocker arm shafts for wear or damage.

Measure the O. D. with a micrometer.

SERVICE LIMIT: 9.92 mm (0.391 in)

Calculate the rocker arm-to-shaft clearance.

SERVICE LIMIT: 0.08 mm (0.003 in)

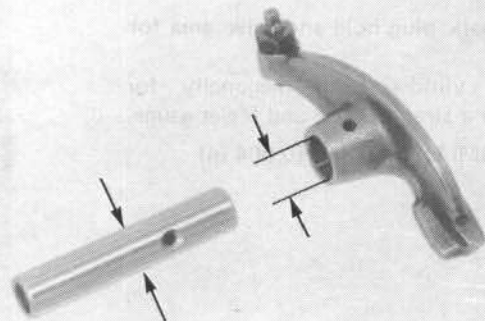

CYLINDER HEAD DISASSEMBLY

Remove the valve cotters, spring retainers and valve springs with a valve spring compressor.

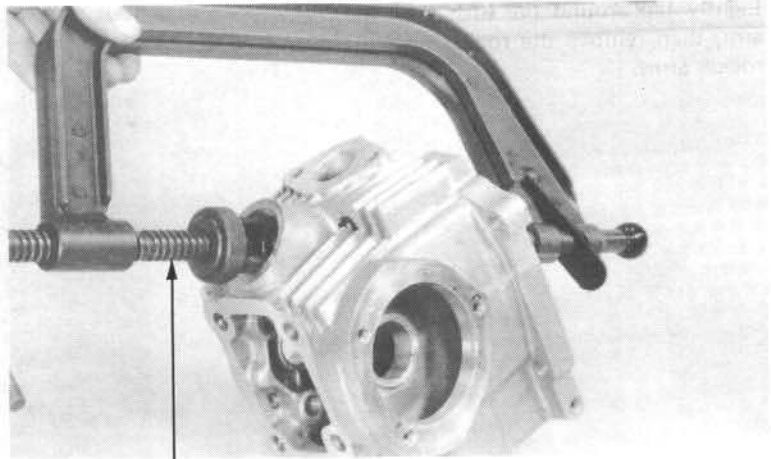

VALVE SPRING COMPRESSOR
07757-0010000 or 07957-3290001

Remove carbon deposits from the combustion chamber.
Clean off any gasket material from the cylinder head surface.

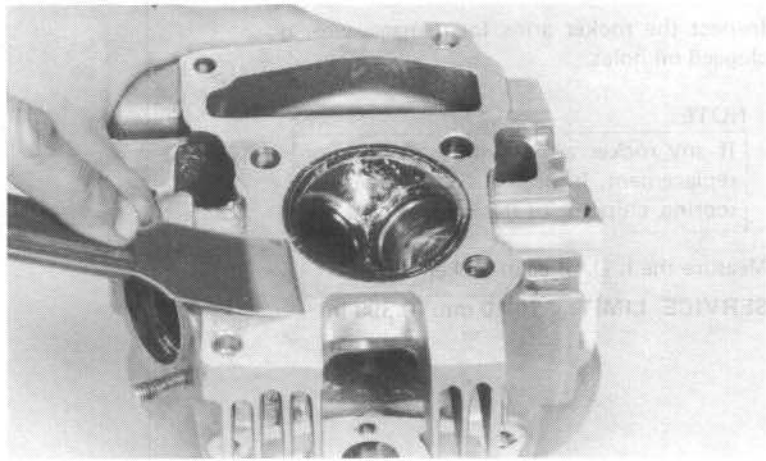

CYLINDER HEAD INSPECTION

Check the spark plug hole and valve area for cracks.

Check the cylinder head diagonally for warpage with a straight edge and feeler gauge.

SERVICE LIMIT: 0.10 mm (0.004 in)

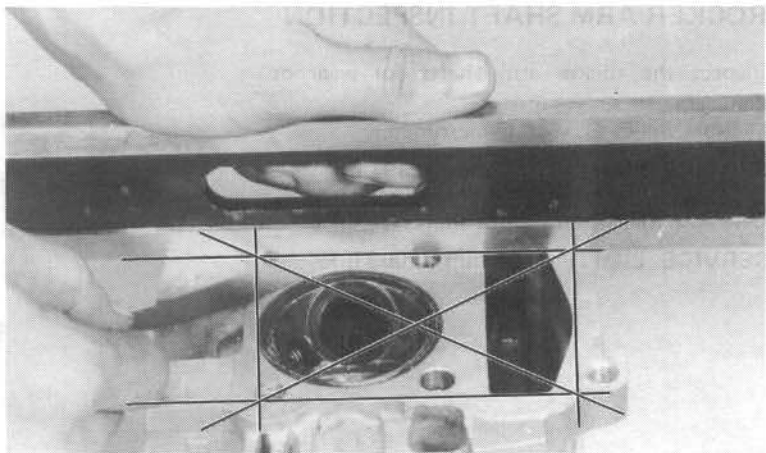

VALVE SPRING INSPECTION

Measure the free length of the inner and outer valve springs.

SERVICE LIMITS:

INNER: 29.9 mm (1.18 in)

OUTER: 33.7 mm (1.32 in)

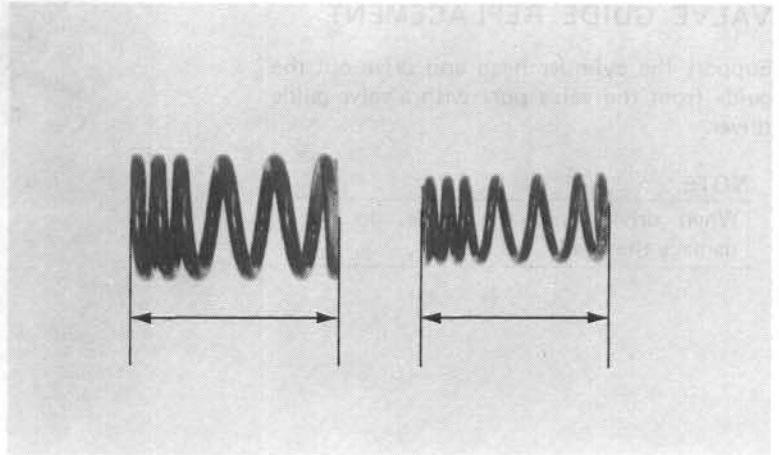

VALVE/VALVE GUIDE INSPECTION

Inspect each valve for trueness, burning, scratches or abnormal stem wear.

Check the valve movement in the guide.

Measure and record each valve stem O. D.

SERVICE LIMITS:

IN: 5.435 mm (0.2139 in)

EX: 5.415 mm (0.2132 in)

Measure and record the valve guide I. D.

NOTE

Ream the guides to remove any carbon build up before checking the valve guide I. D.

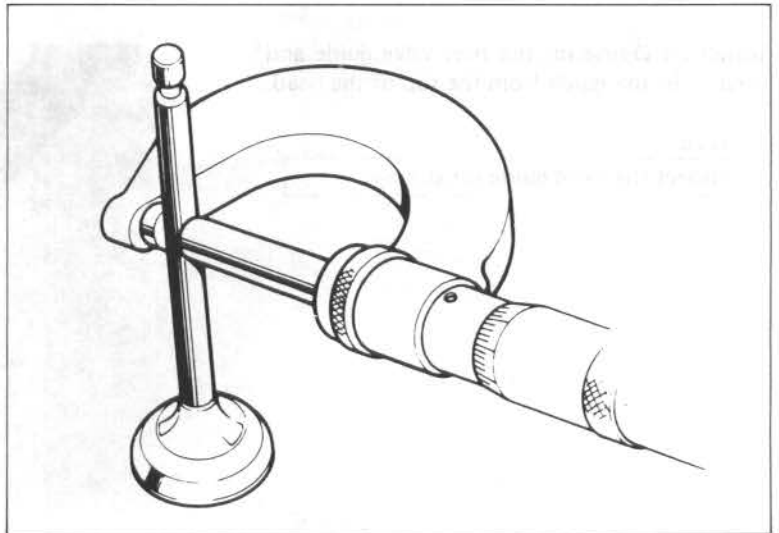

SERVICE LIMIT:

IN/EX: 5.525 mm (0.2175 in)

Calculate the stem-to-guide clearance.

SERVICE LIMITS:

IN: 0.08 mm (0.003 in)

EX: 0.10 mm (0.004 in)

NOTE:

- If the stem-to-guide clearance exceeds the service limit, determine if a new guide with standard dimensions would bring the clearance within tolerance. If so, replace guides as necessary and ream to fit.
- If the valve guide is replaced, the valve seat must be refaced.

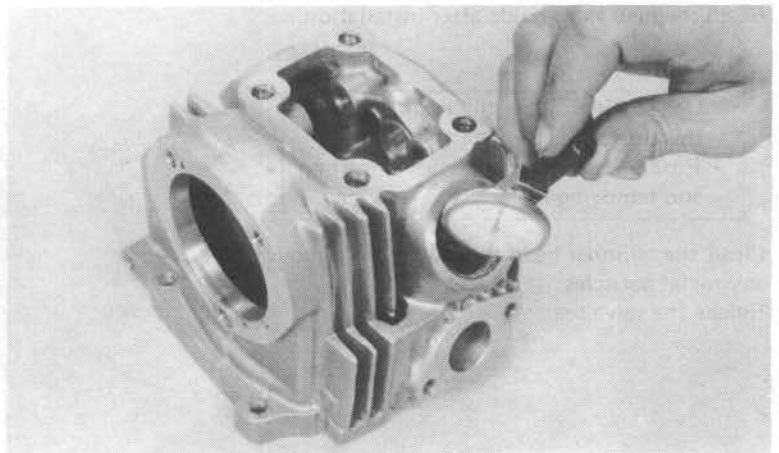

VALVE GUIDE REPLACEMENT

Support the cylinder head and drive out the guide from the valve port with a valve guide driver.

NOTE

When driving out the guide, do not damage the head.

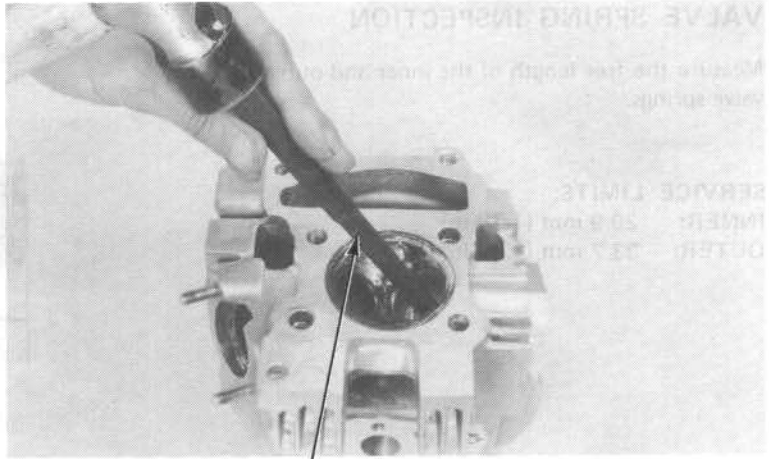

VALVE GUIDE DRIVER, 5.5 mm
07742-0010100 or 07942-3290100

Install an O-ring on the new valve guide and drive it in the guide from the top of the head.

NOTE

Inspect the valve guide for damage.

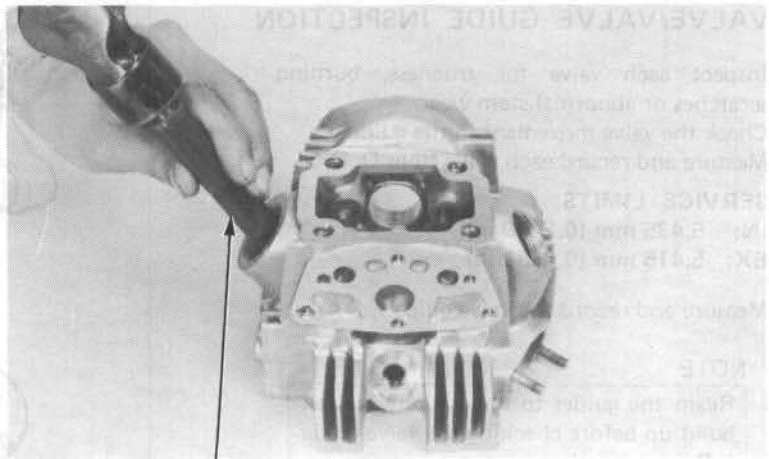

VALVE GUIDE DRIVER
07942-1180100

Ream the new valve guide after installation.

NOTE

- Use cutting oil on the reamer during this operation.
- Rotate the reamer when inserting and removing it.

Clean the cylinder head thoroughly to remove any metal particles.
Reface the valve seat.

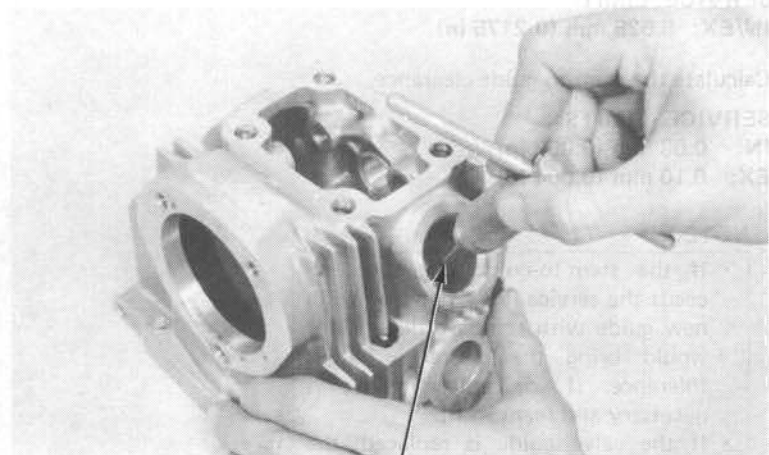

VALVE GUIDE REAMER
07984-0980000

VALVE SEAT INSPECTION/ REFACING

Clean all intake and exhaust valves thoroughly to remove carbon deposits.

Apply a light coating of Prussian Blue to each valve seat. Lap each valve and seat using a hand-lapping tool.

Remove and inspect each valve.

STANDARD:

IN/EX: 1.2–1.5 mm (0.05–0.06 in)

SERVICE LIMIT:

IN/EX: 1.8 mm (0.07 in)

CAUTION

The valves cannot be ground. If a valve face is burned or badly worn or if it contacts the seat unevenly, replace the valve.

Inspect each valve seat.

STANDARD:

IN/EX: 1.0 mm (0.04 in)

SERVICE LIMIT:

IN/EX: 1.6 mm (0.06 in)

If the seat is too wide, too narrow, or has low spots, the seat must be refinished to seal properly.

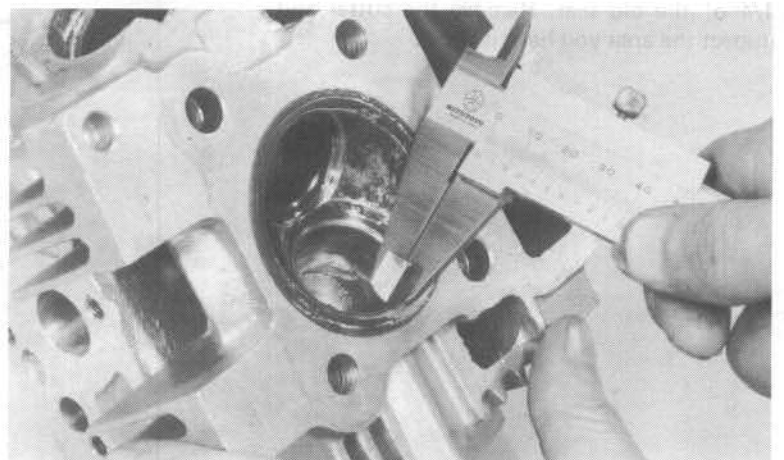
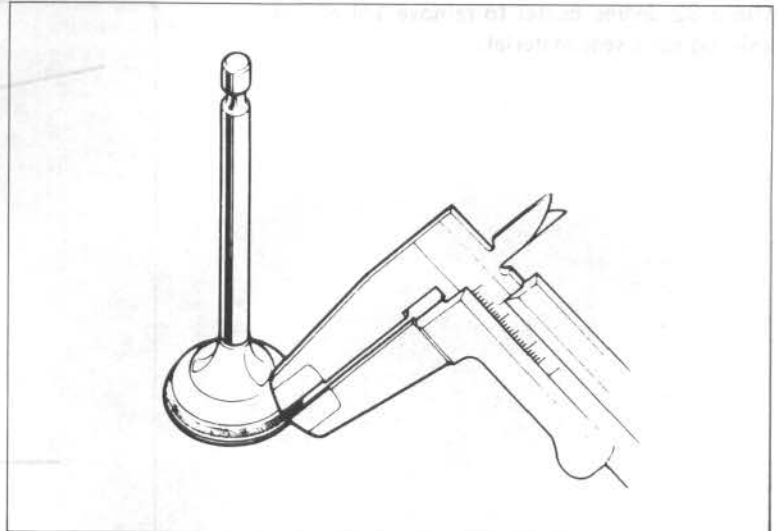

VALVE SEAT GRINDING

Follow the refacer manufacturer's operating instructions.

Use a 45 degree cutter to remove any roughness or irregularities from the seat.

NOTE

Reface the seat with a 45 degree cutter when the valve guide is replaced.

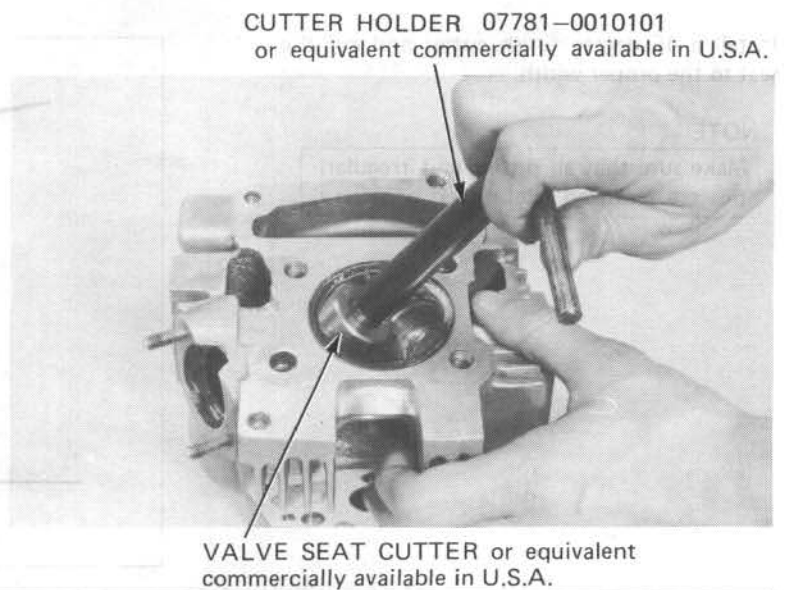

CYLINDER HEAD/VALVES

Use a 32 degree cutter to remove 1/4 of the existing valve seat material.

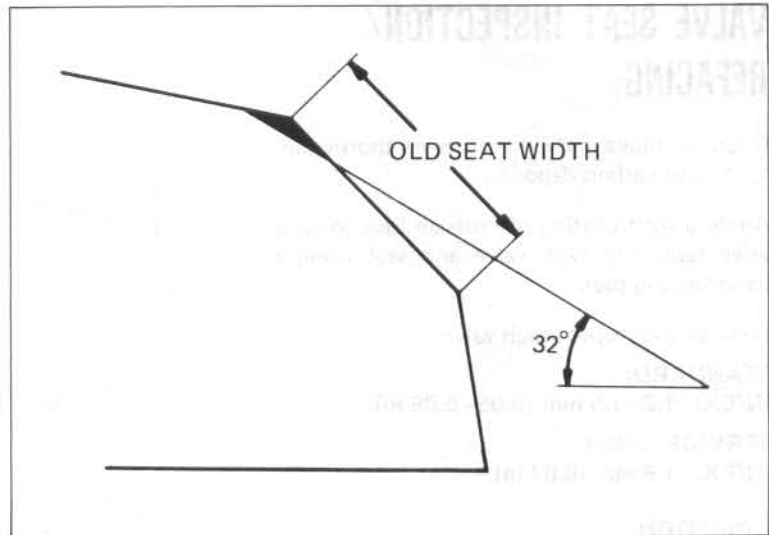

Use a 60 degree cutter to remove the lower 1/4 of the old seat. Remove the cutter and inspect the area you have just cut.

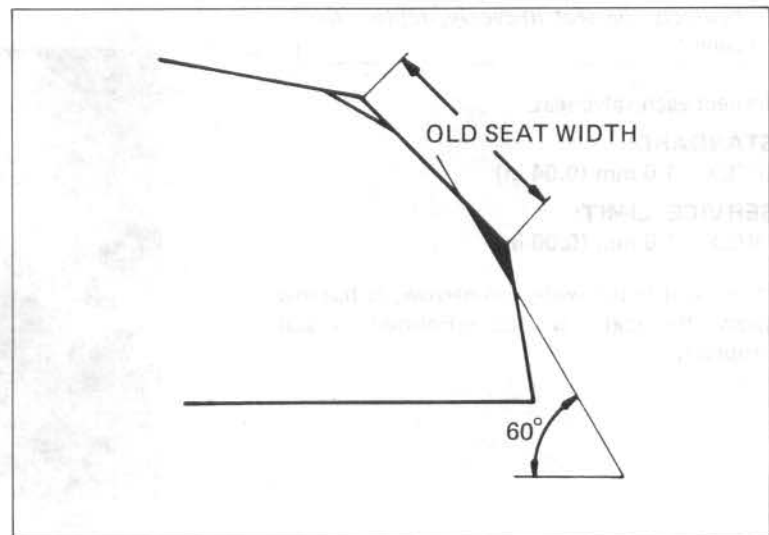

Install a 45 degree finish cutter and cut the seat to the proper width.

NOTE

Make sure that all pitting and irregularities are removed. Refinish if necessary.

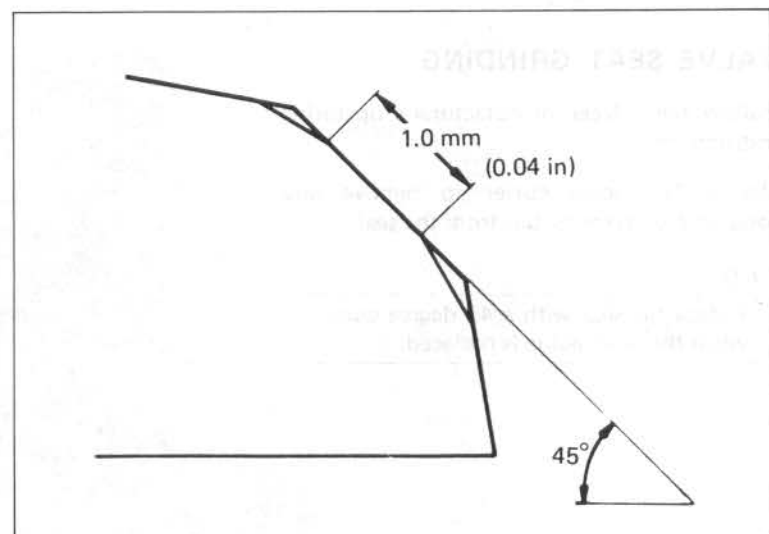

Apply a thin coating of Prussian Blue to the valve seat.

Without rotating the valve, insert the valve through the valve guide and onto the seat to make a clear pattern.

NOTE

The location of the valve seat in relation to the valve face is very important for good sealing.

If the contact area is too high on the valve, the seat must be lowered using a 32 degree flat cutter.

If the contact area is too low on the valve, the seat must be raised using a 60 degree inner cutter.

Refinish the seat to specifications using a 45 degree seat cutter.

After cutting the seat, apply lapping compound to the valve face and lap the valve using light pressure.

After lapping, wash all residual compound off the cylinder head and valve.

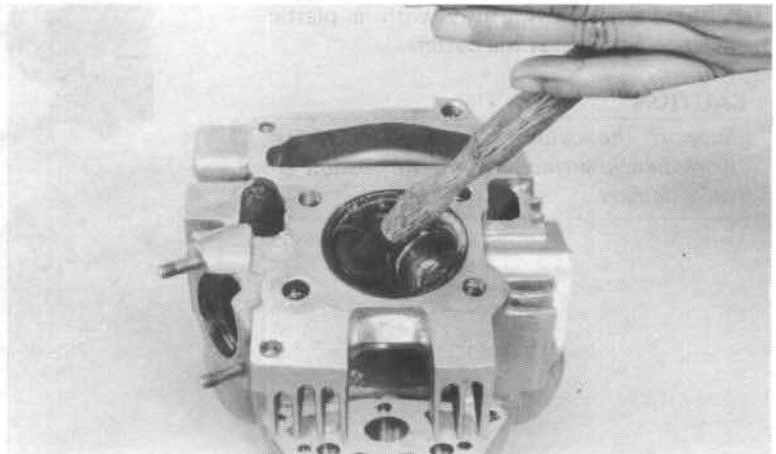
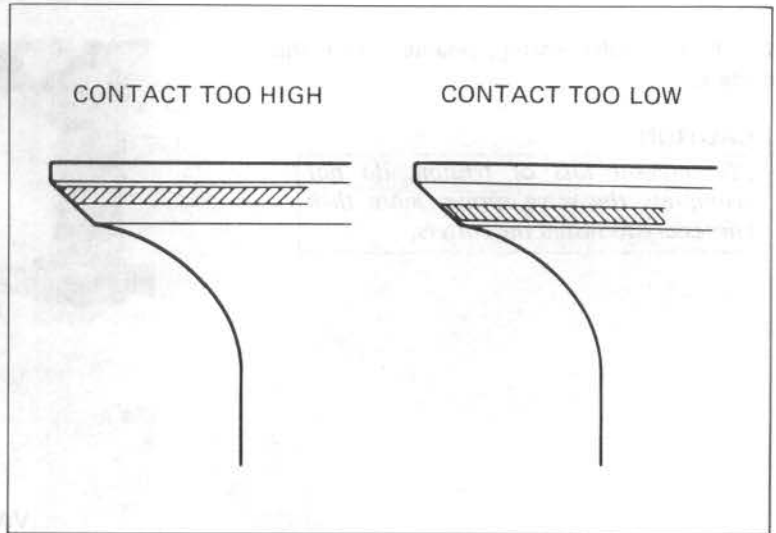

CYLINDER HEAD ASSEMBLY

NOTE

- Install new valve stem seals after disassembling.
- Install the valve springs with the tightly wound coils facing the cylinder head.

Lubricate each valve stem with oil.
Insert the valves into the guides.

Install the valve spring seats and springs.

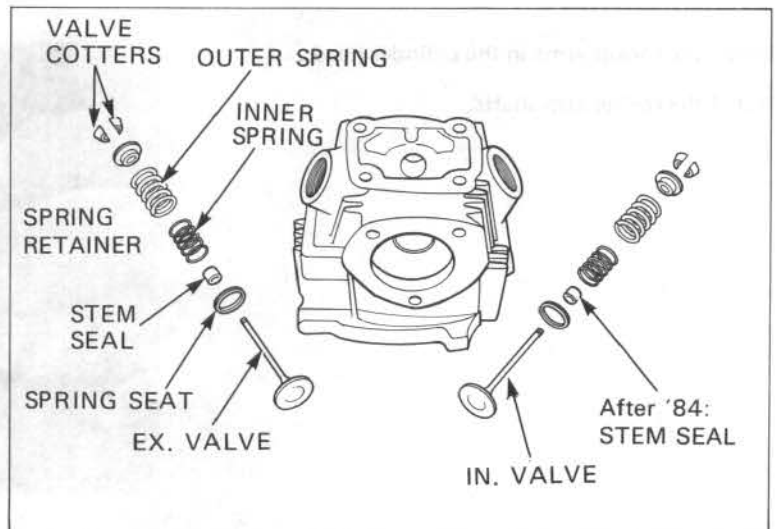

CYLINDER HEAD/VALVES

Install the valve spring, retainers and the cotters.

CAUTION

To prevent loss of tension, do not compress the valve springs more than necessary to install the cotters.

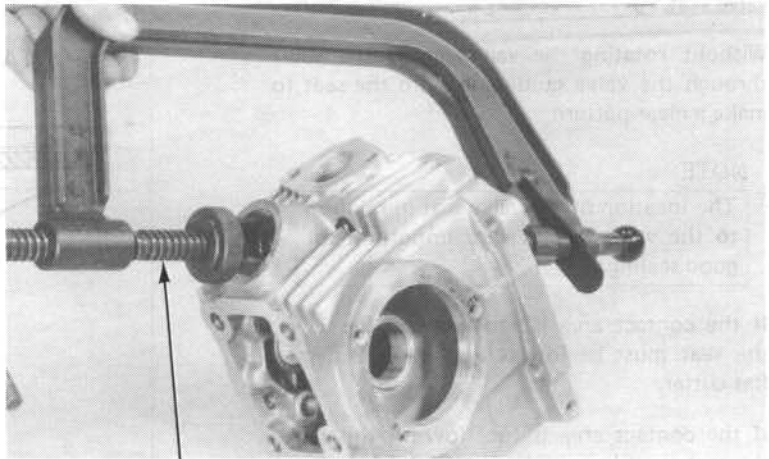

VALVE SPRING COMPRESSOR
07757-0010000 or 07957-3290001

Tap the valve stems gently with a plastic hammer to firmly seat the cotters.

CAUTION

Support the cylinder head above the work bench surface to prevent possible valve damage.

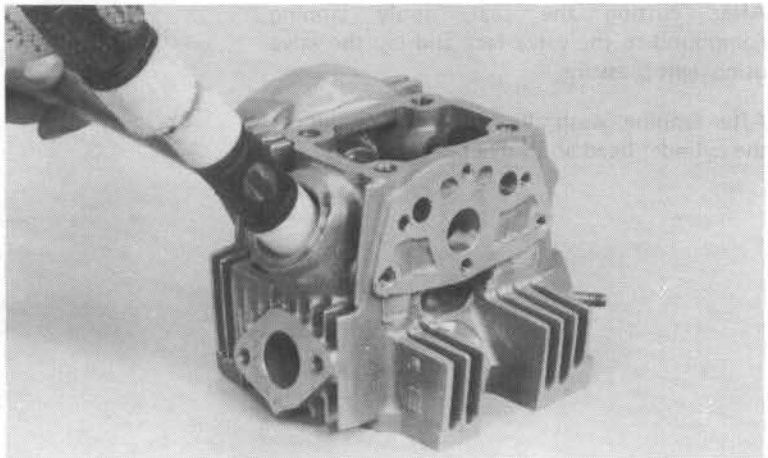

Install the rocker arms in the cylinder head.

Install the rocker arm shafts.

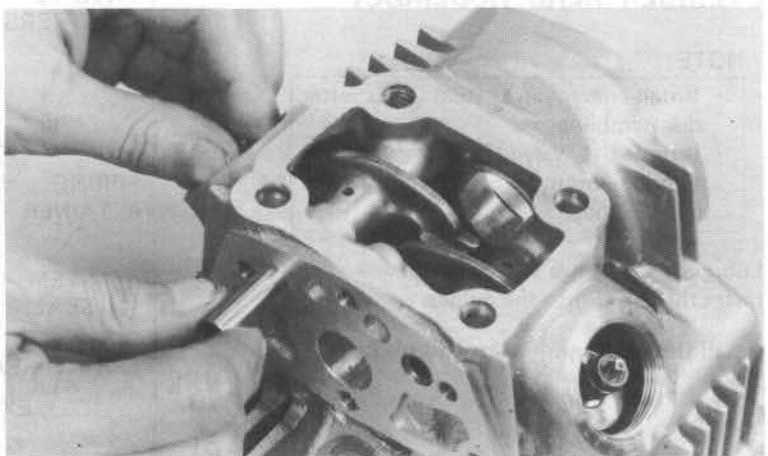

CYLINDER HEAD INSTALLATION

Clean off any gasket material from the cylinder surface.
Install the O-rings, collars, dowel pins and a new gasket.

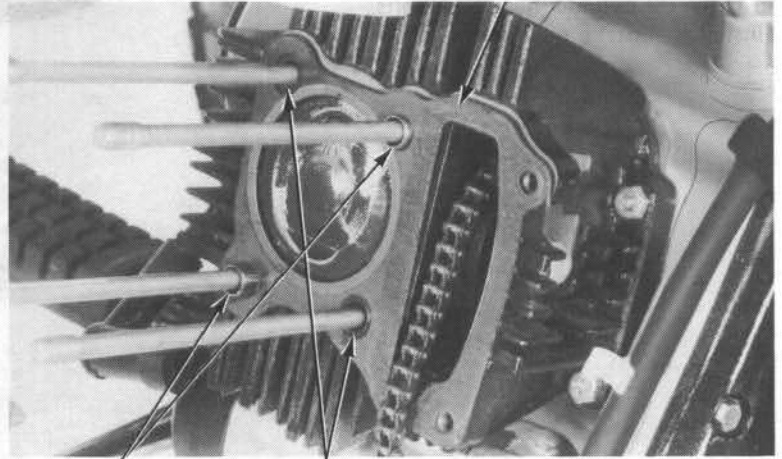

DOWEL PINS

O-RINGS/COLLARS

Install the chain on the cam sprocket as shown.
Face the "O" mark on the sprocket toward the cylinder head.

Install the cylinder head.

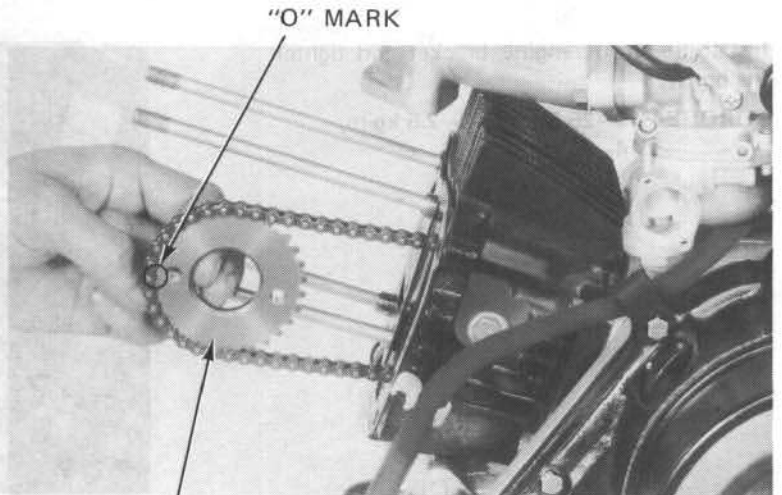

"O" MARK

CAM SPROCKET

Install the cylinder head cover.
Tighten the nuts uniformly.

TORQUE: 18–21 N·m (1.8–2.1 kg-m, 13–15 ft-lb)

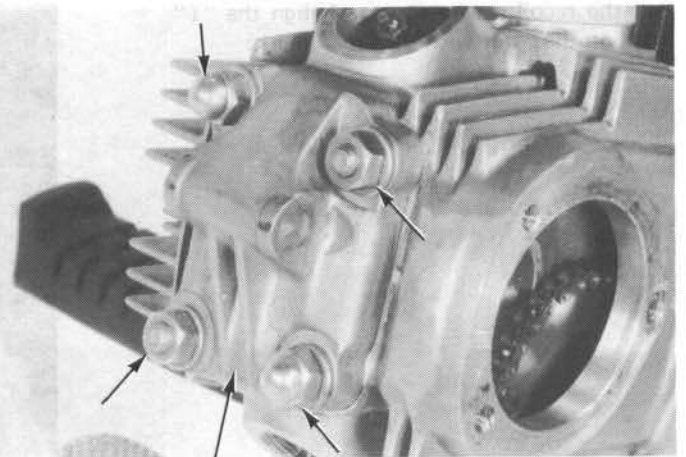

CYLINDER HEAD COVER

CYLINDER HEAD/VALVES

Tighten the cylinder head base bolts.
Install the intake pipe bolts and tighten them.

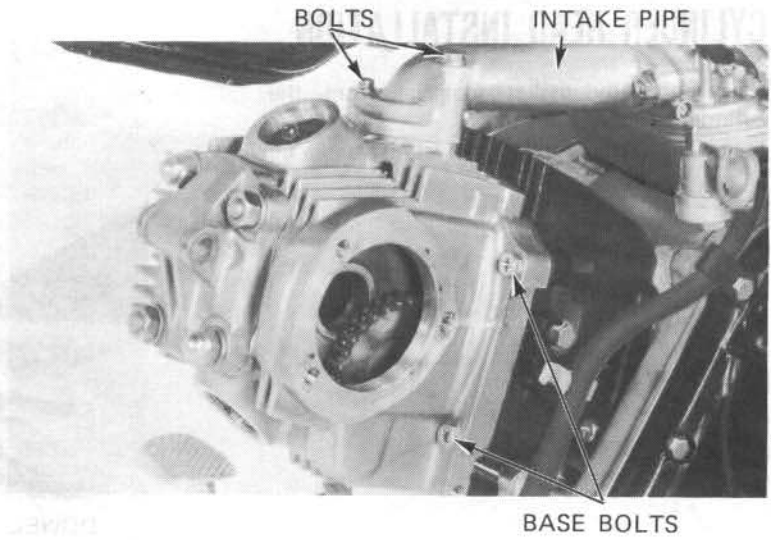

Install the front engine bracket and tighten the bolts.

**TORQUE: 19–25 N·m (1.9–2.5 kg-m,
14–18 ft-lb)**

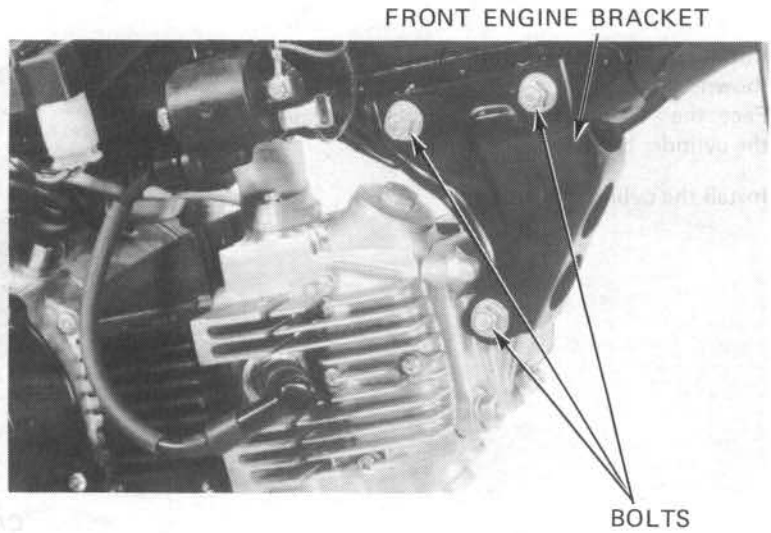

Pull the recoil starter rope and align the "T" mark on the rotor with the index mark.



Coat the camshaft with molybdenum disulfide grease and install it in the cylinder head.

Align the "O" mark on the cam sprocket with the index mark on the cylinder head.

Torque the cam sprocket bolts.

TORQUE: 8–12 N·m (0.8–1.2 kg·m, 6–9 ft·lb)

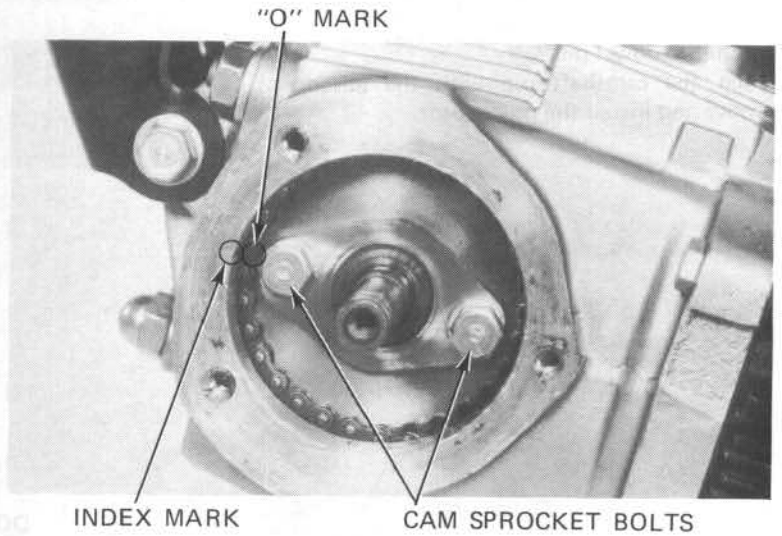

Install the pulse base using the oil seal guide, 07974–1280000 so the oil seal lip does not turn inside out.

Tighten the pulse base with three screws.

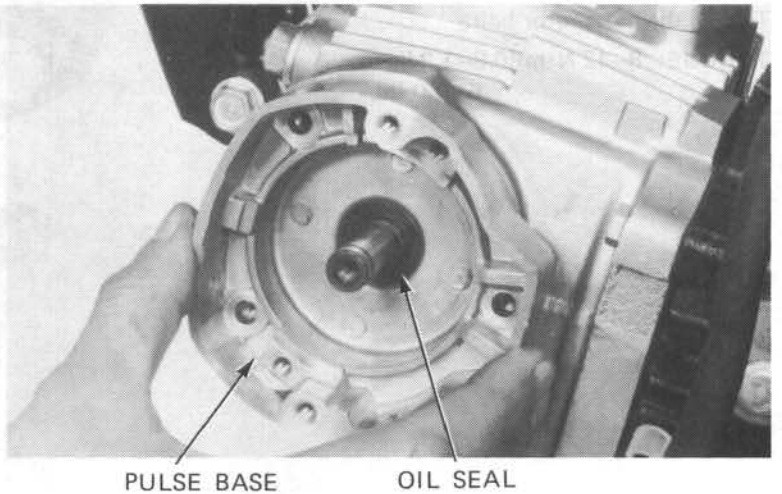

PULSE ROTOR ASSEMBLY

Align the punch mark on the rotor with the index mark on the spark advancer and assemble.

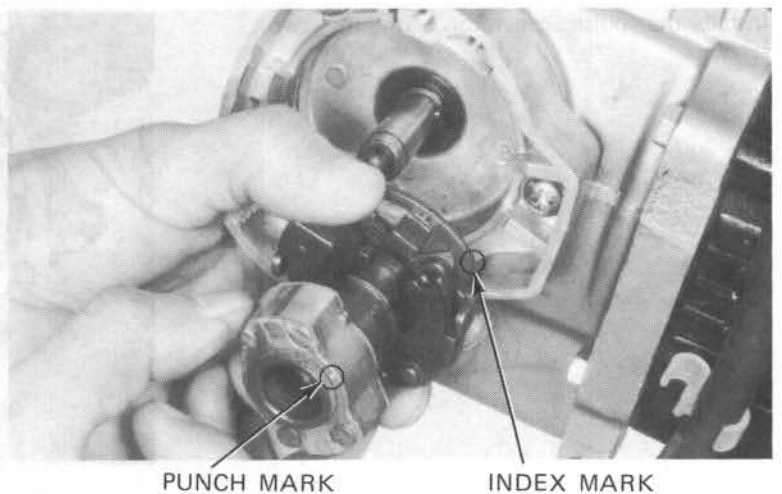

CYLINDER HEAD/VALVES

Install the dowel pin.
Align the camshaft pin with the advancer groove and install the pulse rotor.

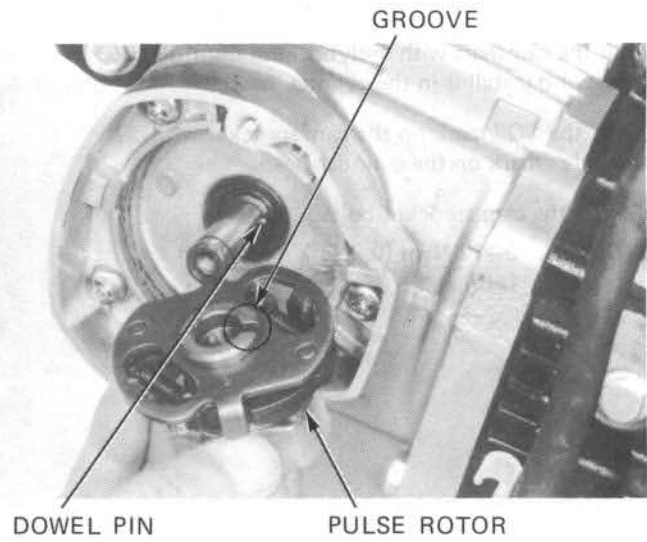

Tighten the pulse rotor bolt.

**TORQUE: 8–12 N·m (0.8–1.2 kg·m,
6–9 ft·lb)**

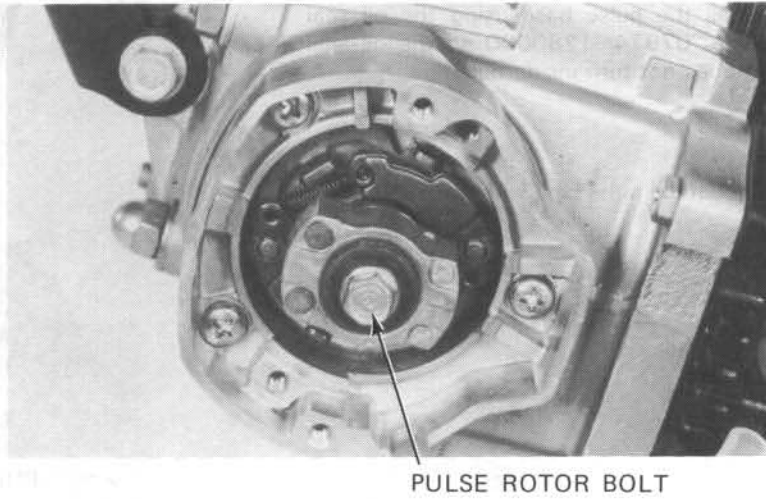

Install the pulse generator with the two screws.

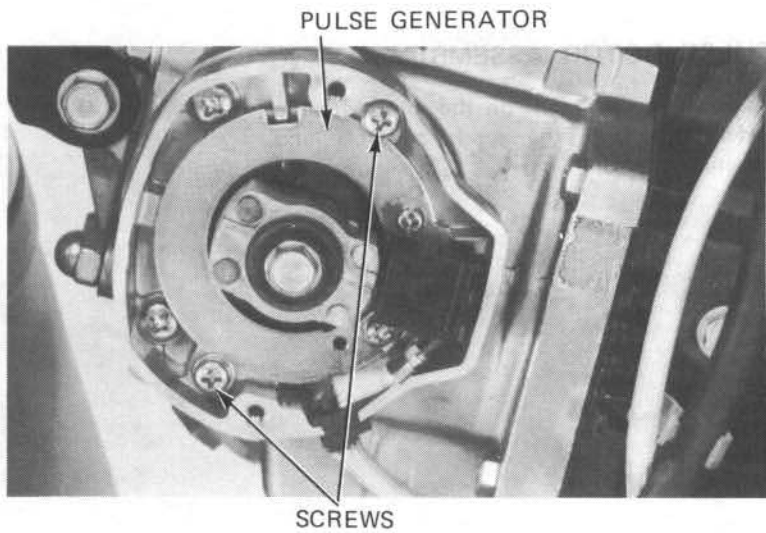

Pull the recoil starter and align the "F" mark with the crankcase cover index mark.

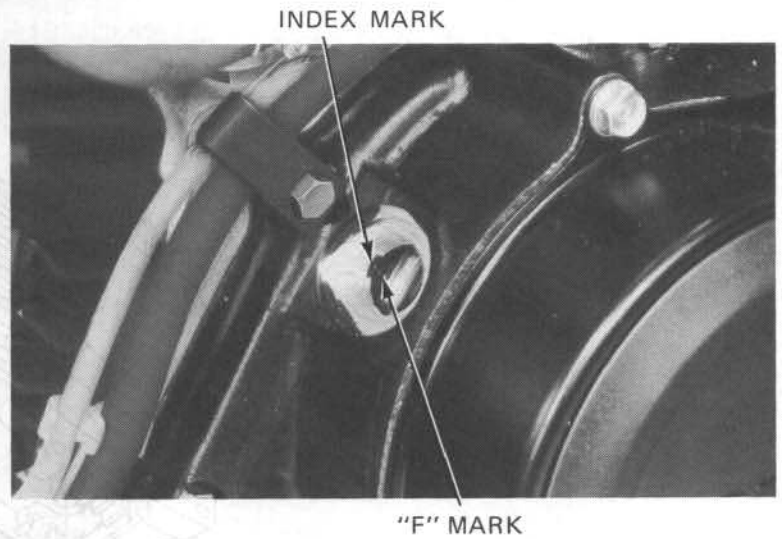

Align the pulse generator tooth with the rotor index mark and tighten the pulse generator base screws.

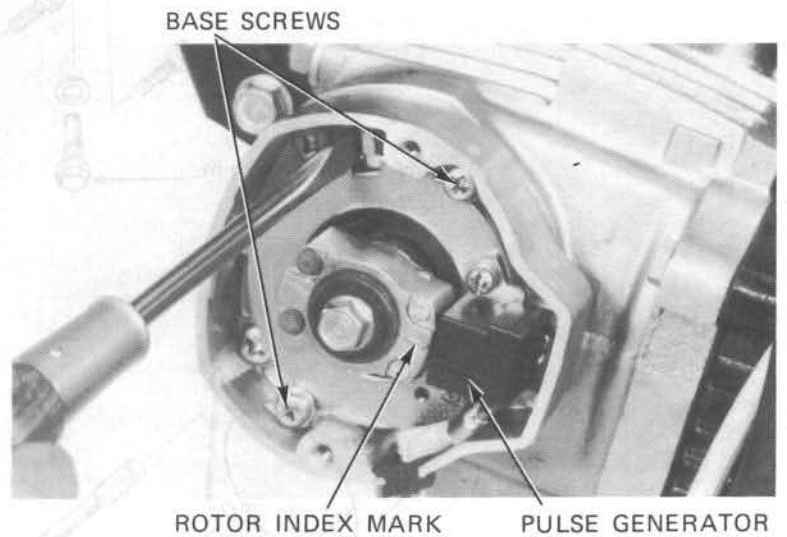

Install the pulse generator cover and tighten the two screws.

Connect the pulse generator wire to the wire harness.

Install the pulse generator wire clamp to the cylinder head using the 6mm bolt.

After assembly, do the following:

- Adjust the valve clearance (Page 3-5).
- Inspect the ignition timing (Page 3-9).
- Test cylinder compression (Page 3-9).
- Adjust the cam chain tension (Page 3-6).

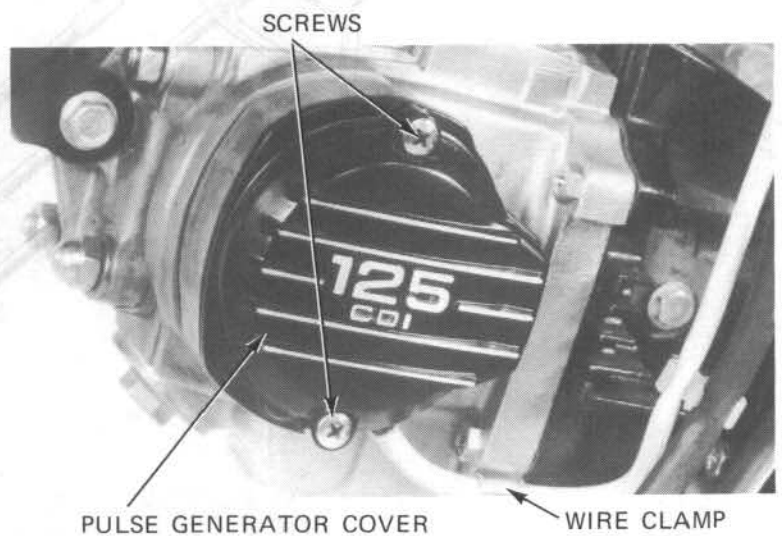

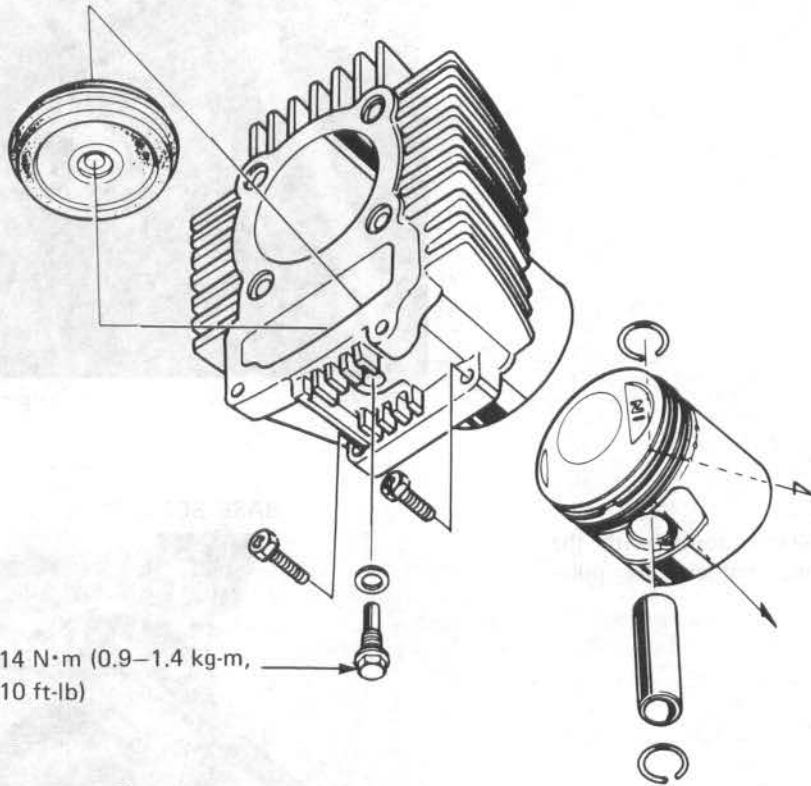

9-14 N·m (0.9-1.4 kg·m,
7-10 ft·lb)

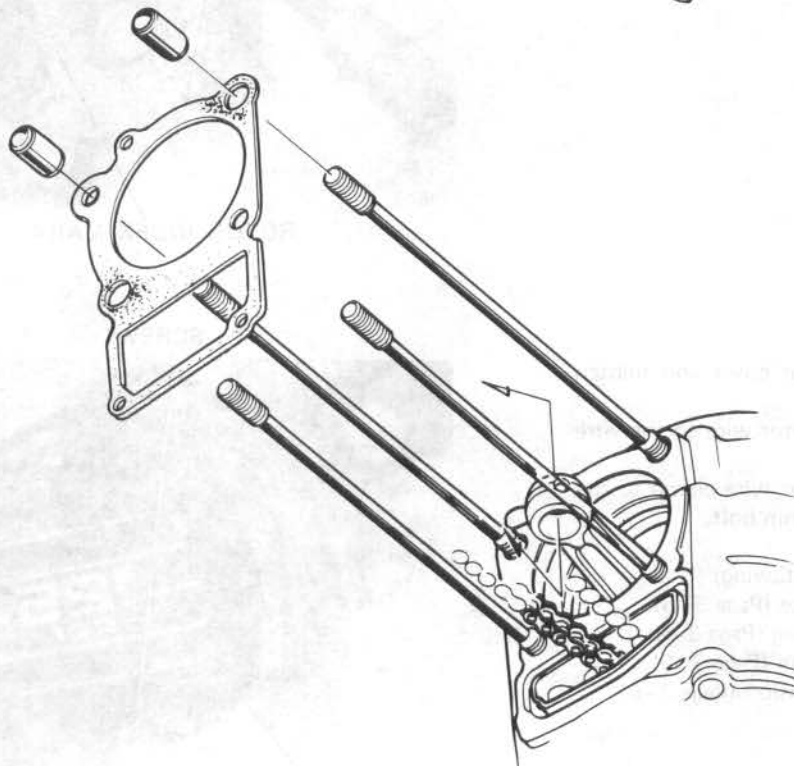

7. CYLINDER/PISTON

SERVICE INFORMATION	7-1
TROUBLESHOOTING	7-1
CYLINDER REMOVAL	7-2
PISTON REMOVAL	7-3
PISTON INSTALLATION	7-6
CYLINDER INSTALLATION	7-6

SERVICE INFORMATION

GENERAL

- Camshaft lubrication oil is fed to the cylinder head through an orifice in the cylinder head and crankcase. Be sure that this orifice is not clogged and that the O-rings and dowel pins are in place before installing the cylinder head.

SPECIFICATIONS

	ITEM	STANDARD	SERVICE LIMIT	
Cylinder	I. D.	55.000–55.010 mm (2.1654–2.1657 in)	55.10 mm (2.169 in)	
	Taper	————	0.05 mm (0.002 in)	
	Out of round	————	0.05 mm (0.002 in)	
	Warpage across top	————	0.10 mm (0.004 in)	
Piston, piston pin, piston rings	Piston O. D.	54.955–54.985 mm (2.2029–2.1648 in)	54.90 mm (2.161 in)	
	Piston pin bore	15.002–15.008 mm (0.5906–0.5909 in)	15.04 mm (0.592 in)	
	Piston pin O. D.	14.994–15.000 mm (0.5903–0.5906 in)	14.96 mm (0.589 in)	
	Piston-to-pin clearance	0.002–0.014 mm (0.0001–0.0006 in)	0.02 mm (0.001 in)	
	Piston ring-to-ring groove clearance	TOP	0.015–0.050 mm (0.0006–0.0020 in)	0.12 mm (0.005 in)
		SECOND	0.010–0.045 mm (0.0004–0.0018 in)	0.12 mm (0.005 in)
	Piston ring end gap	TOP/SEC	0.10–0.25 mm (0.004–0.010 in)	0.50 mm (0.020 in)
OIL		0.3–0.9 mm (0.01–0.04 in)	————	

TORQUE VALUE

Cam chain guide bolt 9–14 N·m (0.9–1.4 kg-m, 7–10 ft-lb)

TROUBLESHOOTING

Low or unstable compression

1. Worn cylinder or piston rings
2. Decompression lever out of adjustment

Excessive smoke

1. Worn cylinder, piston, or piston rings
2. Improper installation of piston rings
3. scored or scratched piston of cylinder wall

Overheating

– Excessive carbon build-up on piston or combustion chamber wall

Knocking or abnormal noise

1. Worn piston and cylinder
2. Excessive carbon build-up

CYLINDER REMOVAL

- Remove the cylinder head (Section 6).
- Remove the gaskets, dowel pins and O-rings.
- Remove the cylinder base bolts.
- Remove the cam chain guide roller bolt and guide roller.
- Remove the cylinder.

NOTE

Keep the cam chain from falling into the crankcase when removing the cylinder.

Remove the gasket and dowel pins.

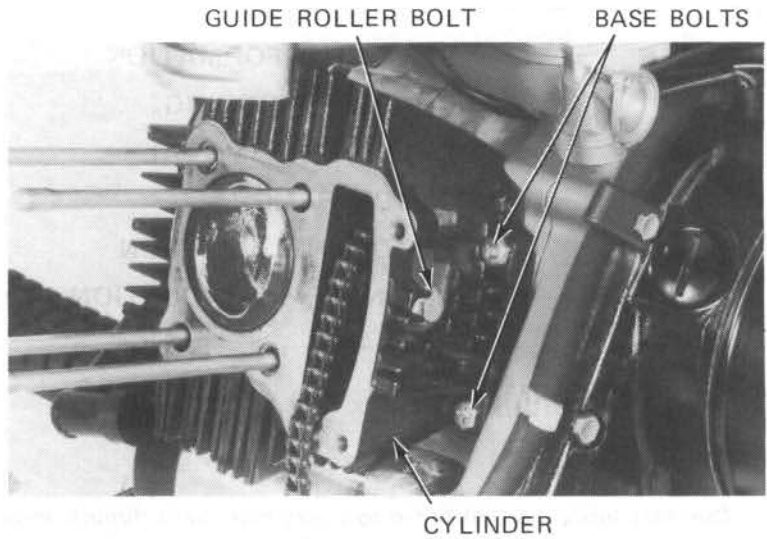

- Clean off any gasket material from the cylinder surface.
- Be careful not to remove any metal.

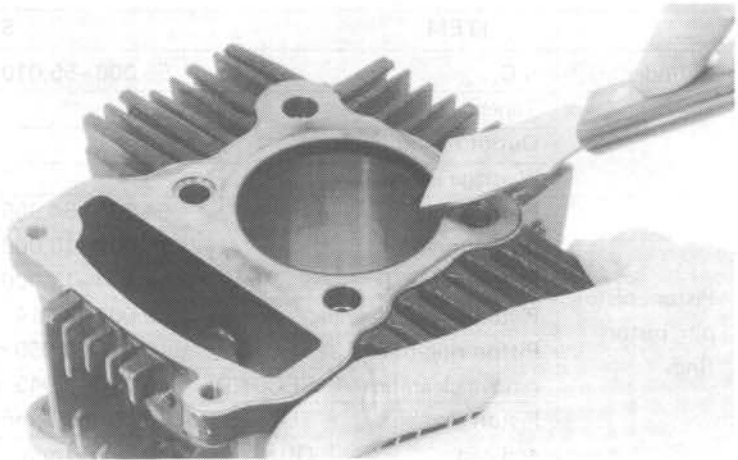

CYLINDER INSPECTION

Inspect the cylinder bore for wear or damage. Measure the cylinder I.D. at X and Y axis at three locations.

SERVICE LIMIT: 55.10 mm (2.169 in)

Calculate the taper and out of round.

SERVICE LIMITS:

- TAPER: 0.05 mm (0.020 in)**
- OUT OF ROUND: 0.05 mm (0.020 in)**

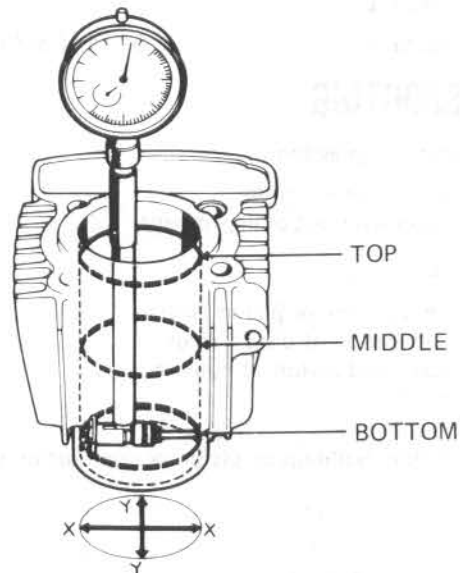

If wear exceeds the service limits, the cylinder should be rebored and oversize piston and piston rings installed.

Oversized piston and rings	Size to which cylinder is to be rebored
0.25 mm (0.01 in)	55.250–55.260 mm (2.1752–2.1756 in)
0.50 mm (0.02 in)	55.500–55.510 mm (2.1850–2.1854 in)

Inspect the top of the cylinder for warpage.

SERVICE LIMIT: 0.10 mm (0.004 in)

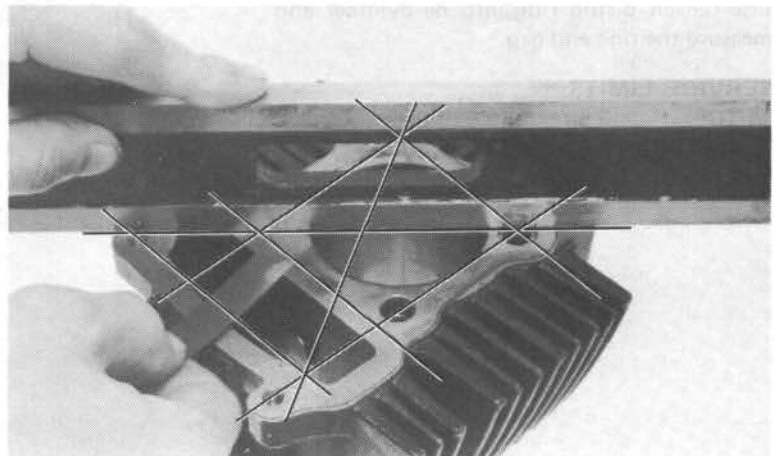

PISTON REMOVAL

Stuff a shop towel into the crankcase.

Remove the piston pin clips with needle nose pliers.

NOTE

Do not let the clips fall into the crankcase.

Press the piston pin out of the piston.
Remove the piston.

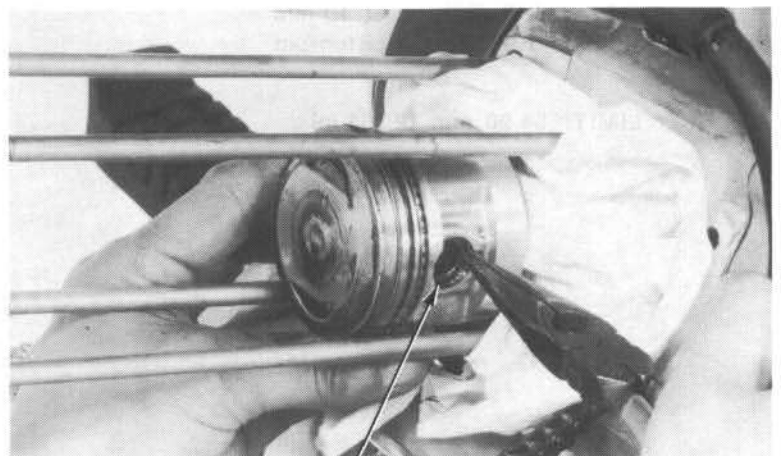

PISTON PIN CLIP

PISTON/PISTON RING INSPECTION

Measure the piston ring-to-groove clearance.

SERVICE LIMITS:

TOP: 0.12 mm (0.005 in)

SECOND: 0.12 mm (0.005 in)

Remove the piston rings, being careful not to damage them.

Inspect the piston for wear or damage.



Insert each piston ring into the cylinder and measure the ring end gap.

SERVICE LIMITS:

TOP: 0.50 mm (0.020 in)

SECOND: 0.50 mm (0.020 in)



Measure the piston skirt diameter at 10 mm from the bottom and 90° to the piston pin bore.

SERVICE LIMIT: 54.90 mm (2.161 in)



Measure the piston pin hole I. D.

SERVICE LIMIT: 15.04 mm (0.592 in)

Measure the piston pin O. D.

SERVICE LIMIT: 14.96 mm (0.589 in)

Calculate the piston-to-piston pin clearance.

SERVICE LIMIT: 0.02 mm (0.001 in)

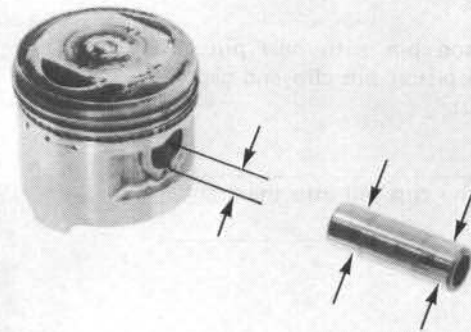

PISTON RING INSTALLATION

Clean the piston ring grooves thoroughly and install the piston rings with the marks facing up.

NOTE

- Avoid piston and piston ring damage during installation.
- Do not mix the top and second rings.

Space the piston ring end gaps 120 degrees apart. Do not align the gaps in the oil rings (side rails).

After installation, the rings should be free to rotate in the ring grooves.

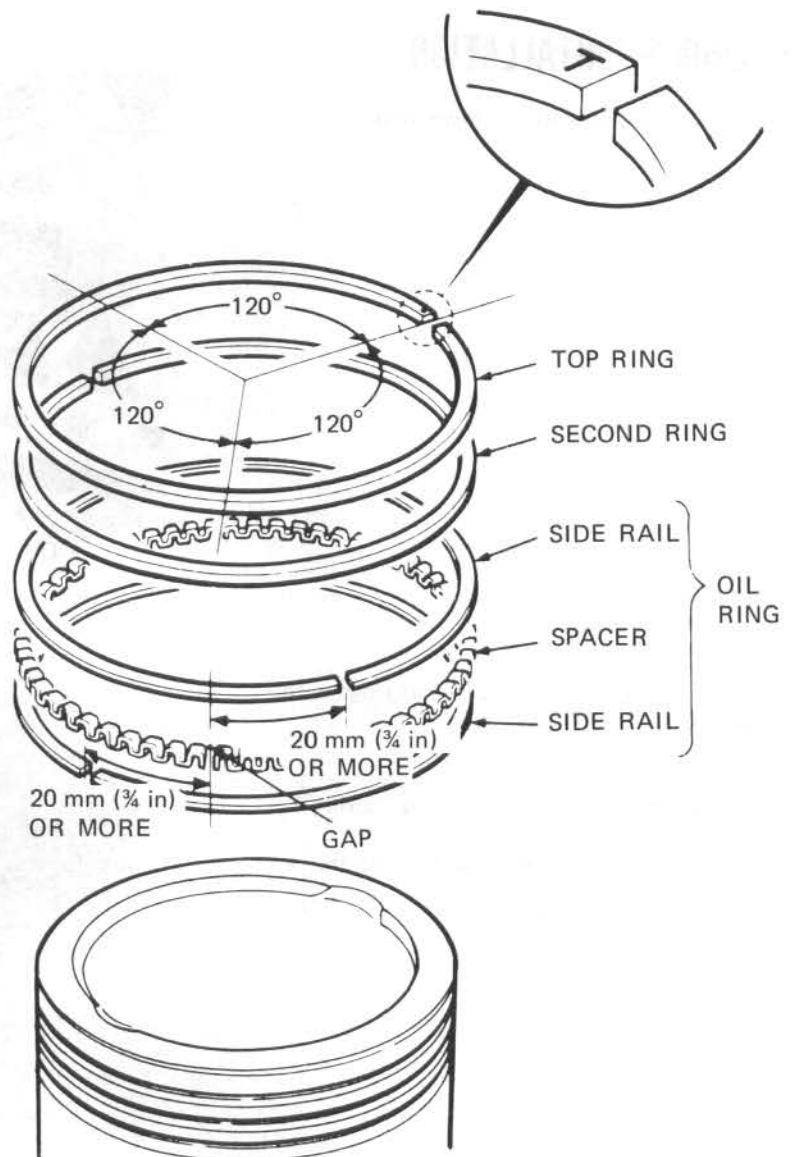
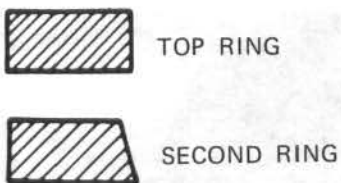

PISTON INSTALLATION

Install the piston with its "IN" mark on the intake valve side.

Install the piston pin with new pin clips. Don't align the piston pin clip end gap with the piston cutout.

NOTE

Do not let the clip fall into the crankcase.



CYLINDER INSTALLATION

Install a new gasket and the dowel pins.

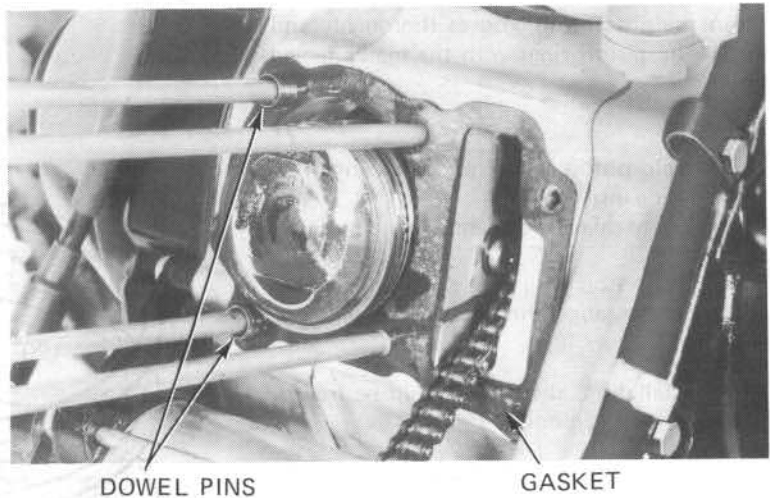

Coat the cylinder bore and piston rings with engine oil and install the cylinder.

NOTE

- Avoid piston ring damage during installation.
- Do not let the cam chain fall into the crankcase.

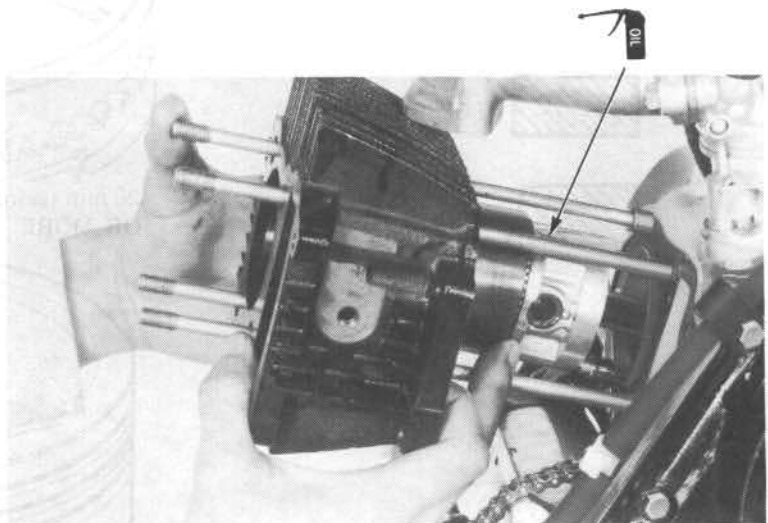

Install the cam chain guide and tighten the guide bolt.

TORQUE: 9–14 N·m
(0.9–1.4 kg-m, 7–10 ft-lb)

Tighten the cylinder base bolts.

Install the cylinder head (Section 6).

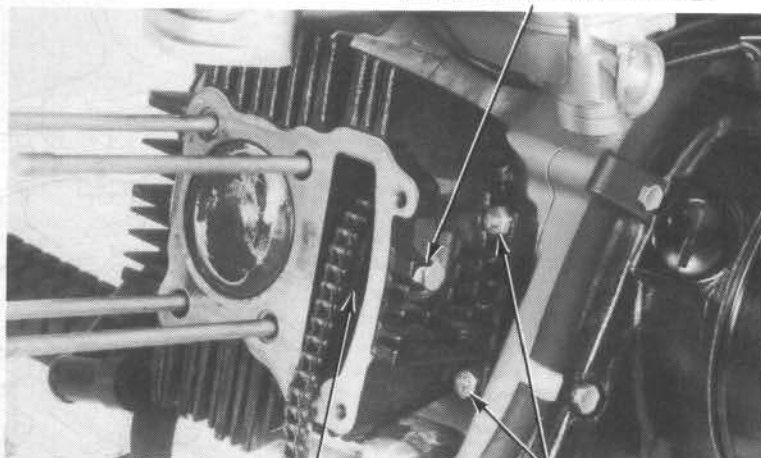

CAM CHAIN GUIDE BOLT

CAM CHAIN GUIDE

CYLINDER BASE BOLTS

CLUTCH/OIL PUMP

18–22 N·m
(1.8–2.2 kg-m, 13–16 ft-lb)

40–50 N·m (4.0–5.0
kg-m, 29–36 ft-lb)

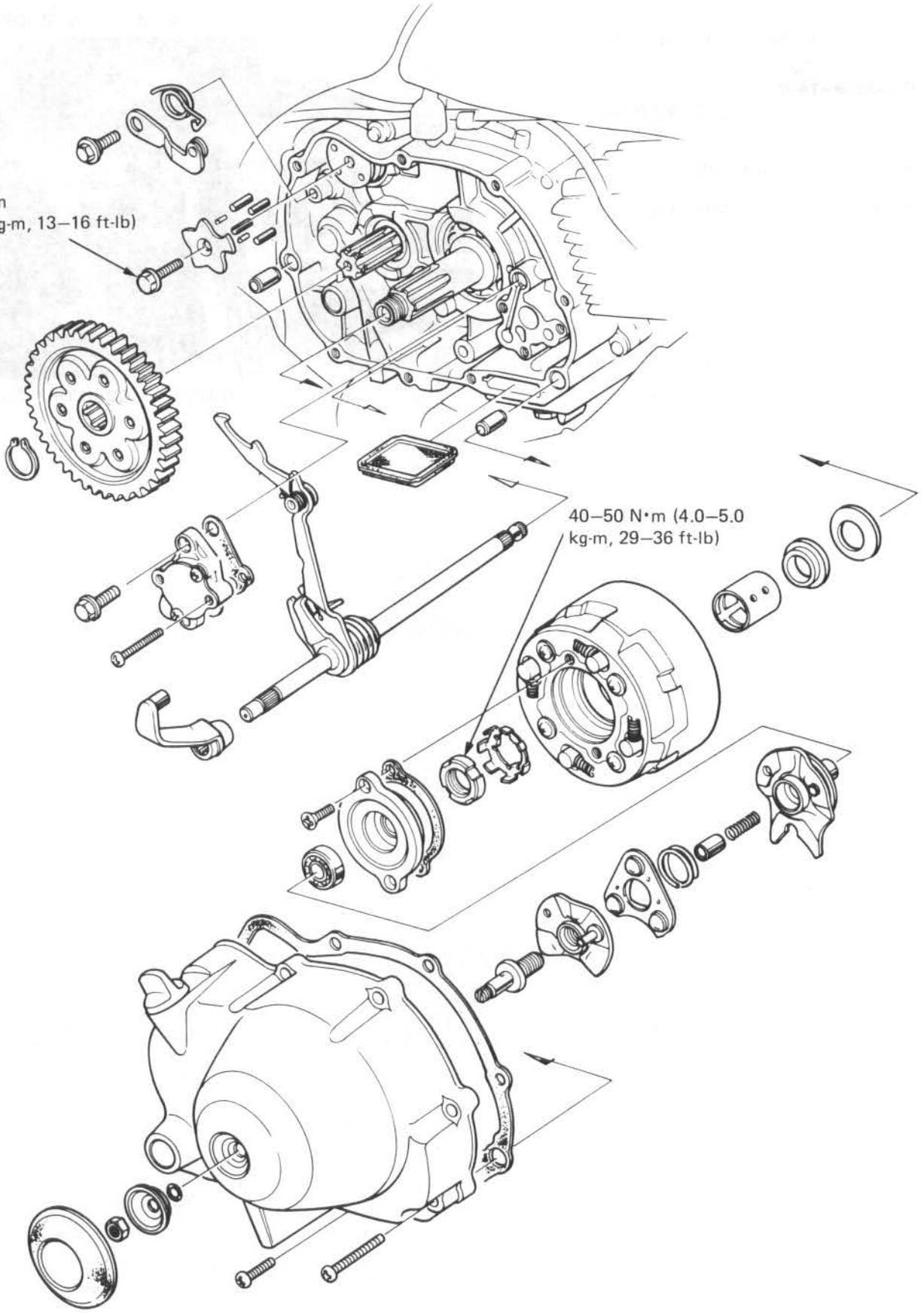

8. CLUTCH/OIL PUMP

SERVICE INFORMATION	8-1	CLUTCH ASSEMBLY	8-9
TROUBLESHOOTING	8-2	CLUTCH INSTALLATION	8-10
RIGHT CRANKCASE COVER REMOVAL	8-3	RIGHT CRANKCASE COVER INSTALLATION	8-12
CLUTCH REMOVAL	8-4	OIL PUMP	8-14
CLUTCH DISASSEMBLY	8-6	GEARSHIFT LINKAGE	8-16

SERVICE INFORMATION

GENERAL

- The clutch, oil pump and gearshift linkage can be serviced with the engine in the frame.

SPECIFICATIONS

ITEM		STANDARD		SERVICE LIMIT
Clutch	Spring free length	21.1 mm	(0.83 in)	20.2 mm (0.80 in)
	Warpage	—		0.20 mm (0.008 in)
	Disc thickness	2.65 – 2.75 mm	(0.104–0.108 in)	2.5 mm (0.10 in)
	Drive gear I.D.	24.000 – 24.021 mm	(0.9449–0.9457 in)	24.10 mm (0.949 in)
	Center guide O.D.	22.00 – 22.10 mm	(0.866–0.870 in)	21.85 mm (0.860 in)
Oil pump	Body clearance	0.15 – 0.20 mm	(0.006–0.008 in)	0.25 mm (0.010 in)
	Tip clearance	0.15 mm	(0.006 in)	0.20 mm (0.008 in)

TORQUE VALUES

Clutch lock nut	40–50 N•m (4.0–5.0 kg-m, 29–36 ft-lb)
Drum stopper plate bolt	18–22 N•m (1.8–2.2 kg-m, 13–16 ft-lb)

TOOLS

Special

Clutch Outer Holder	07923–0340000 (or Flywheel holder 07725–0040000 or Band strap wrench commercially available in U.S.A.)
---------------------	--

Common

Lock Nut Wrench, 20 x 24 mm	07716–0020100 (or 07916–3710000 or 07916–6390001)
Extension	07716–0020500 (or equivalent commercially available in U.S.A.)

TROUBLESHOOTING

Faulty clutch operation can usually be corrected by adjusting the clutch.

Clutch slips when accelerating

1. Faulty clutch lifter
2. Discs worn
3. Spring weak

Clutch will not disengage

1. Faulty clutch lifter
2. Plates warped

Motorcycle creeps with clutch disengaged

1. Faulty clutch
2. Plates warped

Clutch operation feels rough

- Outer drum slots rough

Hard to shift

1. Stopper plate damaged
2. Incorrect clutch adjustment
3. Faulty clutch lifter

Gearshift pedal will not return

1. Weak or broken shift return spring
2. Shift spindle binding with case

Transmission jumps out of gear

- Weak or broken stopper spring

Low oil pressure

1. Faulty oil pump
2. Oil pump drive gear broken

RIGHT CRANKCASE COVER REMOVAL

Drain oil from the engine.
Remove the seat and rear fender.

Remove the 6 mm screws and remove the right crankcase cover and starter motor bracket.

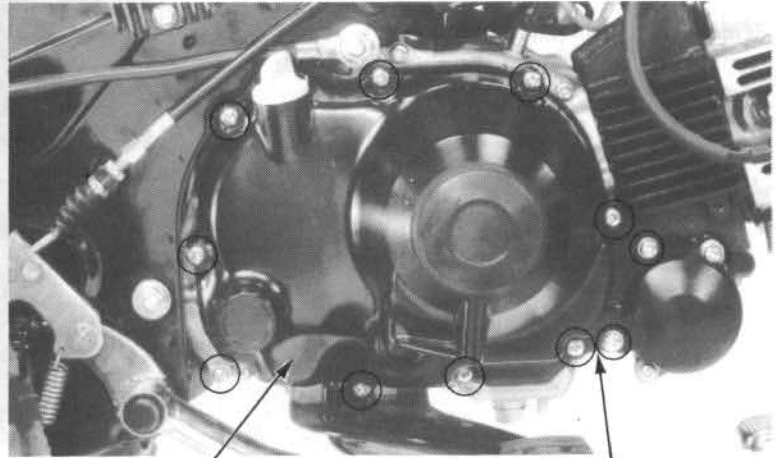

RIGHT CRANKCASE COVER STARTER MOTOR BRACKET

CLUTCH LIFTER REMOVAL/ INSTALLATION

Remove the lifter cap.
Remove the clutch adjusting lock nut, washer and O-ring.

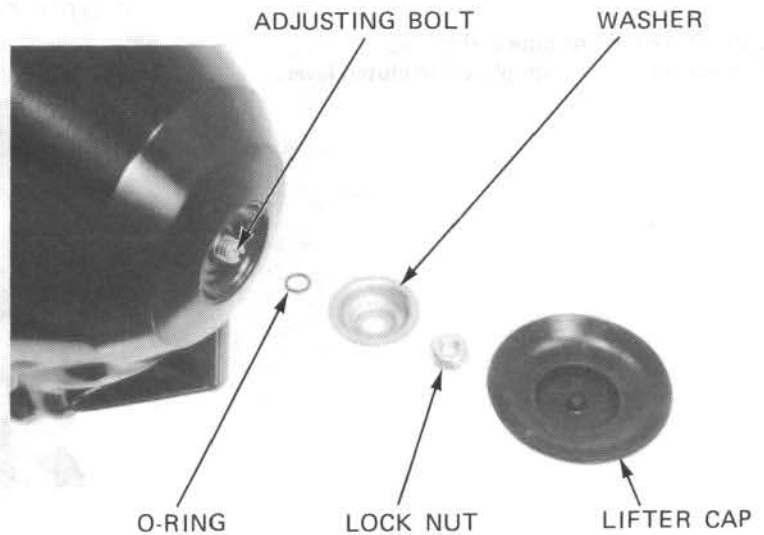

O-RING LOCK NUT WASHER LIFTER CAP

Installation is essentially the reverse of removal.

When installing the clutch lifter, align the clutch lifter pin with the right crankcase cover hole.

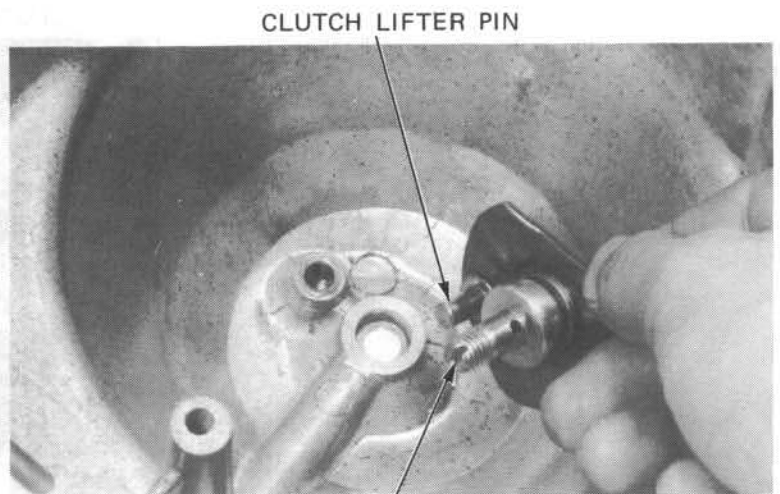

ADJUST BOLT

CLUTCH REMOVAL

Remove the dowel pins and gasket.
Remove the ball retainer and clutch plate side spring.

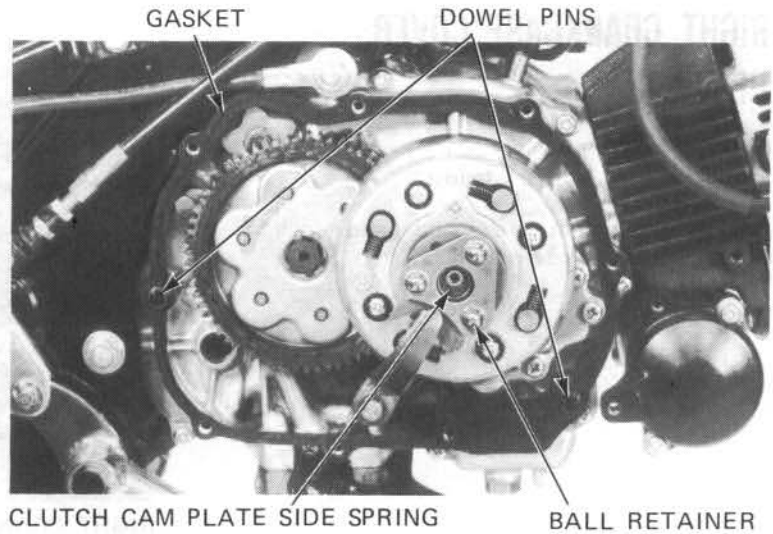

Remove the oil pass pipe and spring.
Remove the clutch cam plate and clutch lever.

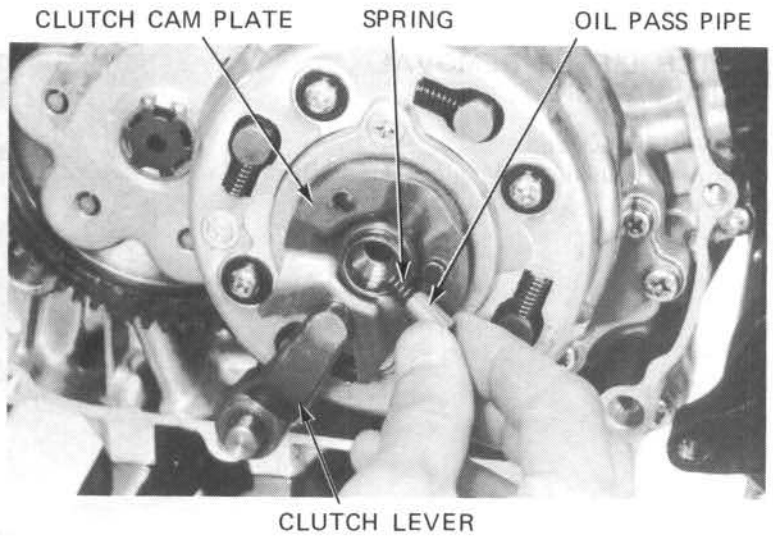

Remove the clutch outer cover and release bearing.

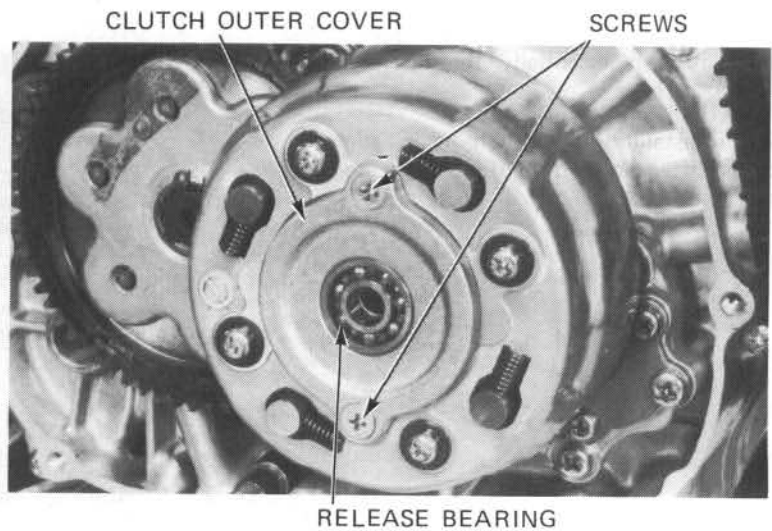

Bend down the lock washer tab.

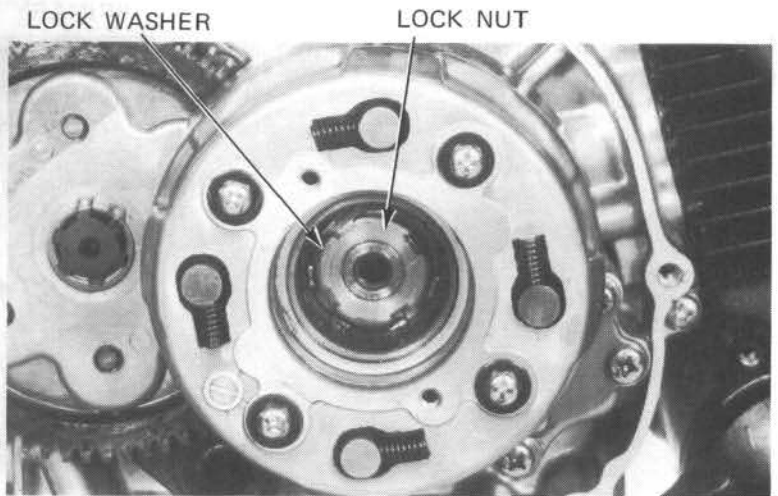

Hold the clutch outer and remove the lock nut.
Remove the clutch assembly.

CLUTCH OUTER HOLDER 07923-0340000
or BAND STRAP WRENCH commercially available
in U.S.A. or FLYWHEEL HOLDER 07725-0040000

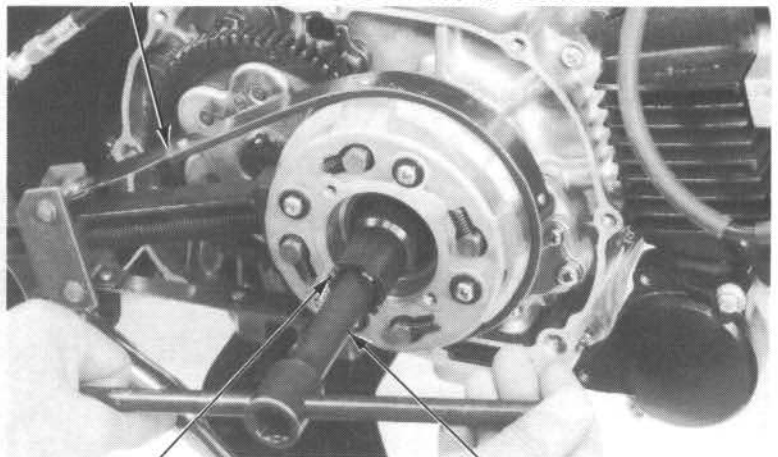

LOCK NUT WRENCH, 20 x 24 mm
07716-0020100 or
07916-3710000 or
07916-6390000

EXTENSION
07716-0020500
or equivalent commercially
available in U.S.A.

Remove the collar, clutch center guide, and
spring washer.

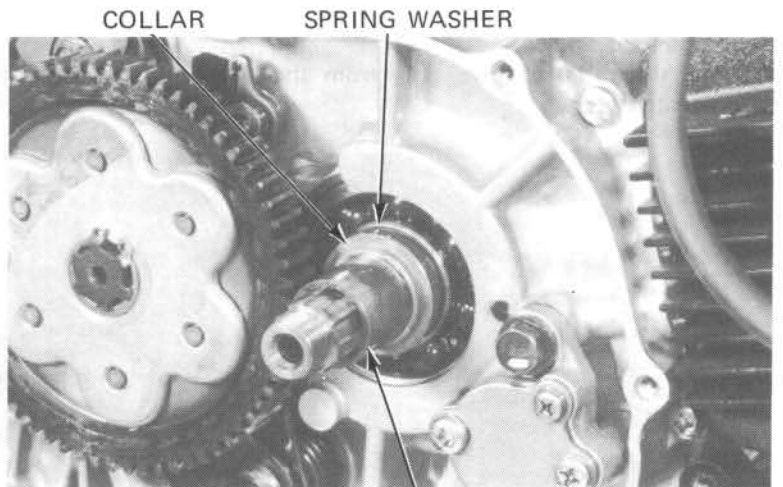

CLUTCH CENTER GUIDE

CLUTCH/OIL PUMP

Remove the snap ring and primary driven gear.

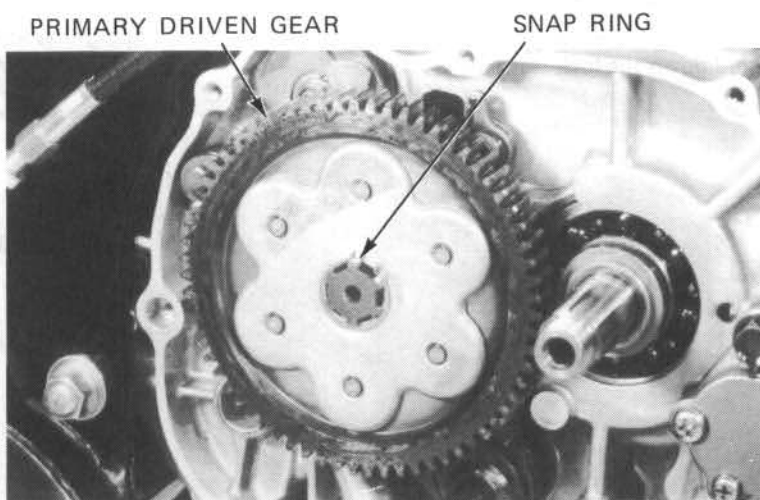

CLUTCH DISASSEMBLY

Pry the set ring off the groove with a screwdriver.
Remove the clutch plates, discs and center.

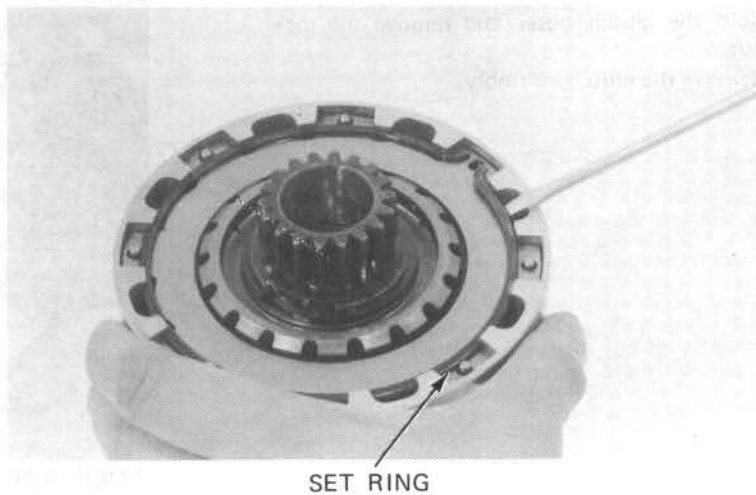

Remove the snap ring.
Remove the primary drive gear from the clutch center.

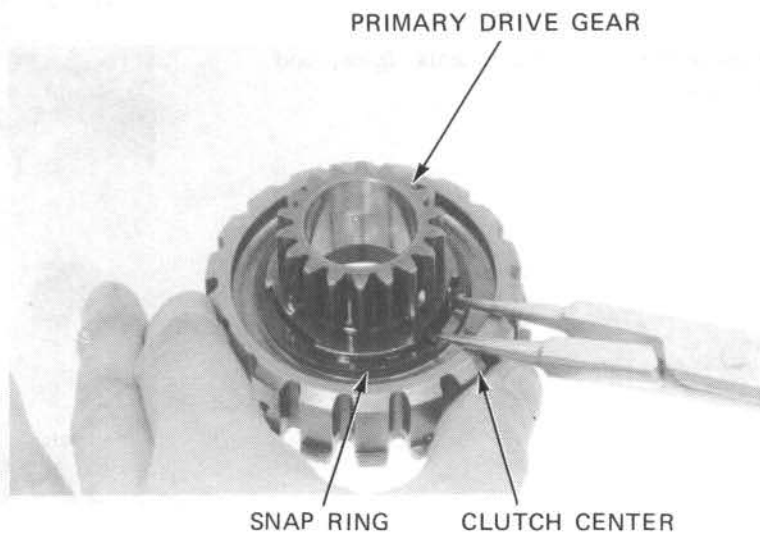

Remove the clutch damper springs.
Place a wood block under the drive plate.

Remove the 5 mm screws, loosening 2–3 turns at a time while pushing down on the clutch outer.

Remove the clutch springs under the 5 mm screws.

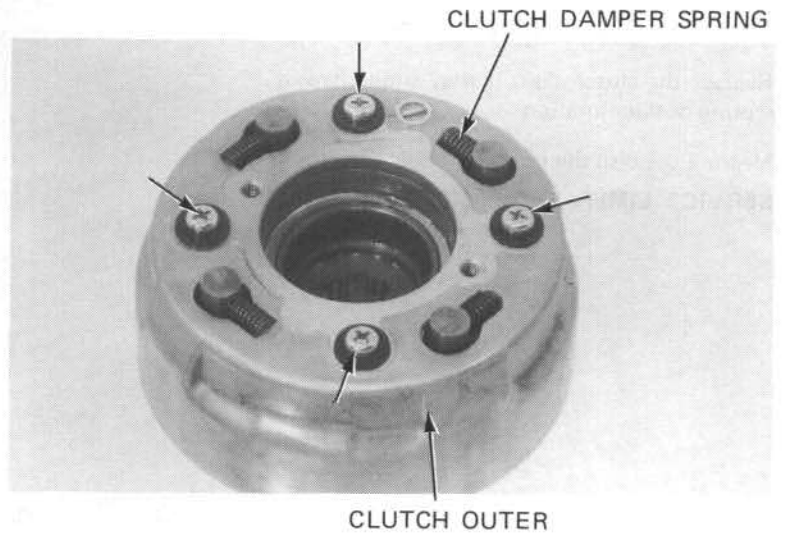

Remove the clutch weight stopper ring with a screwdriver, then remove the clutch weight.

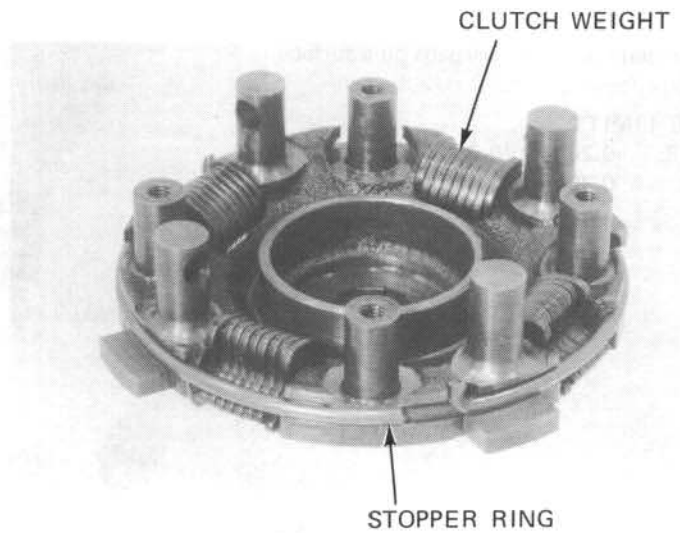

CLUTCH SPRING INSPECTION

Measure the spring free length.

SERVICE LIMIT: 20.2 mm (0.80 in)

CLUTCH SPRING

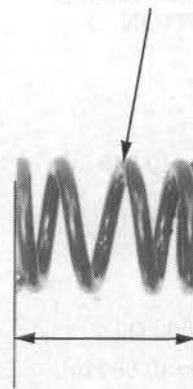

CLUTCH/OIL PUMP

CLUTCH DISC INSPECTION

Replace the clutch discs if they show signs of scoring or discoloration.

Measure the disc thickness.

SERVICE LIMIT: 2.50 mm (0.098 in)

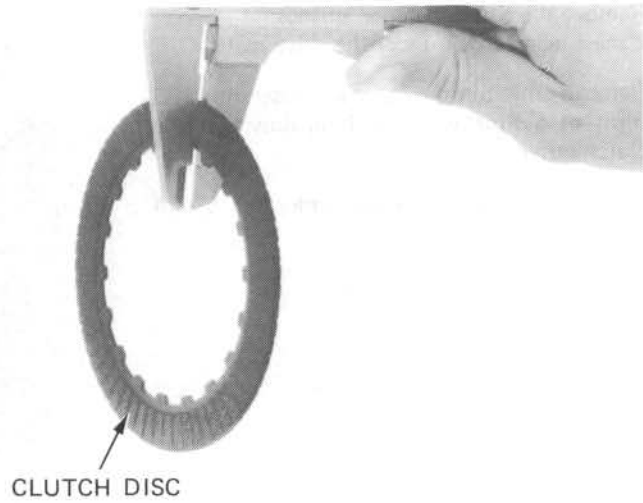

Check for plate and disc warpage on a surface plate using a feeler gauge.

SERVICE LIMITS:

PLATE: 0.20 mm (0.008 in)

DISC: 0.20 mm (0.008 in)

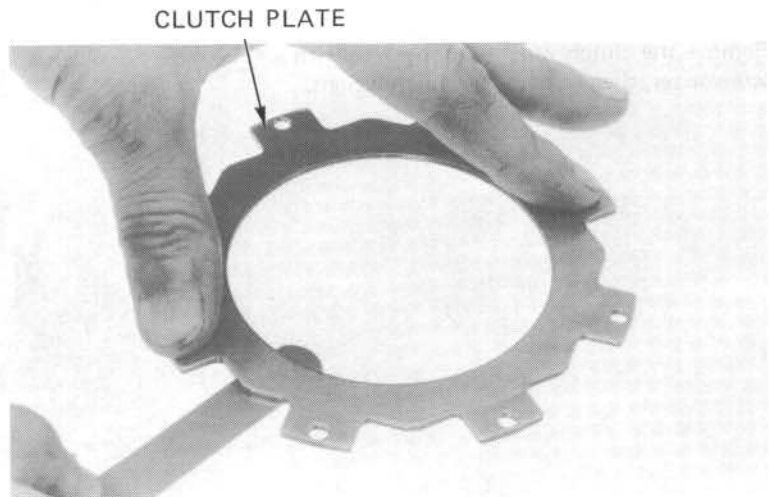

DRIVE GEAR INSPECTION

Check for wear or damage.

Measure the drive gear I.D.

SERVICE LIMIT: 24.10 mm (0.949 in)

CLUTCH CENTER GUIDE INSPECTION

Check for wear or damage.

Measure the clutch center guide O.D.

SERVICE LIMIT: 21.85 mm (0.860 in)

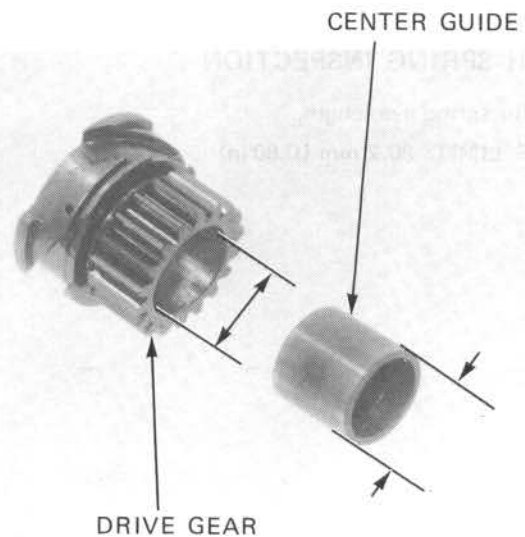

CLUTCH ASSEMBLY

Install the clutch weight.

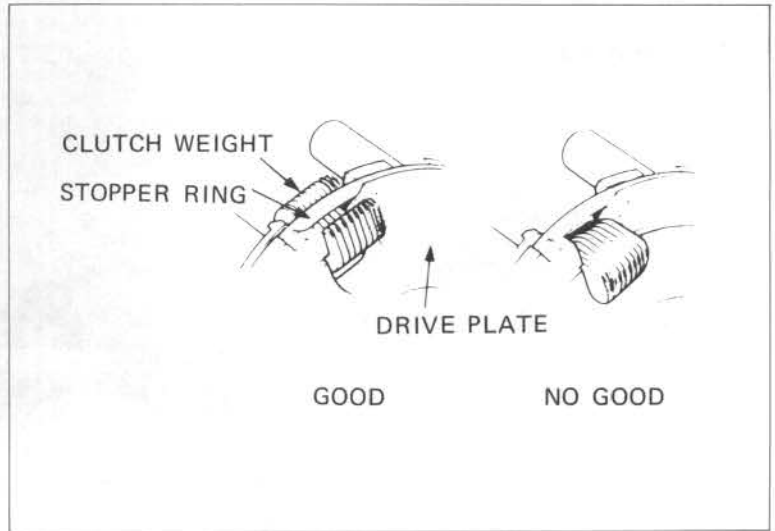

Place the clutch springs on the drive plate and install the drive plate on the clutch outer.

NOTE

Tighten the screws in 2–3 steps in a crisscross pattern.

Install the clutch damper springs.



Install the primary drive gear in the clutch center.

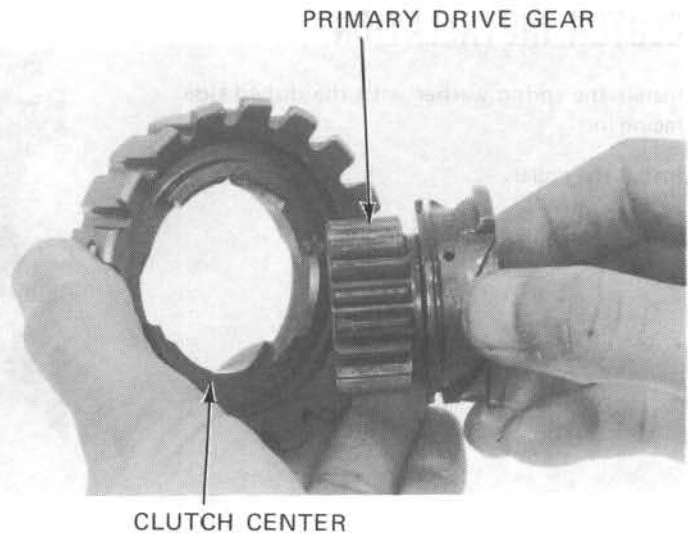

CLUTCH/OIL PUMP

Install the snap ring.

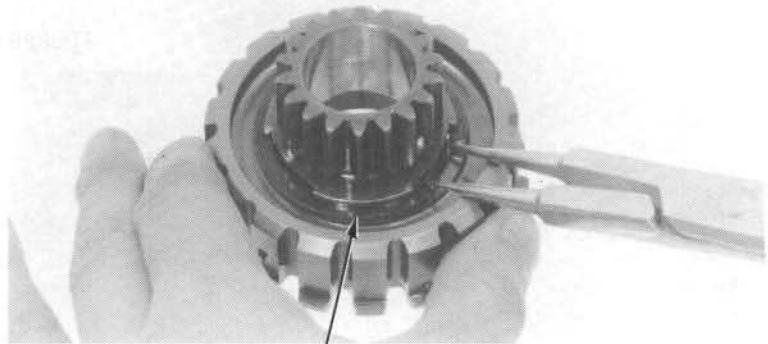

SNAP RING

Place the primary drive gear and clutch center on the drive plate.

Assemble the plates, discs, springs and sub-springs and install them in the clutch outer.

NOTE

Position the clutch springs between plates A and D, and the sub-springs between plates A and C.

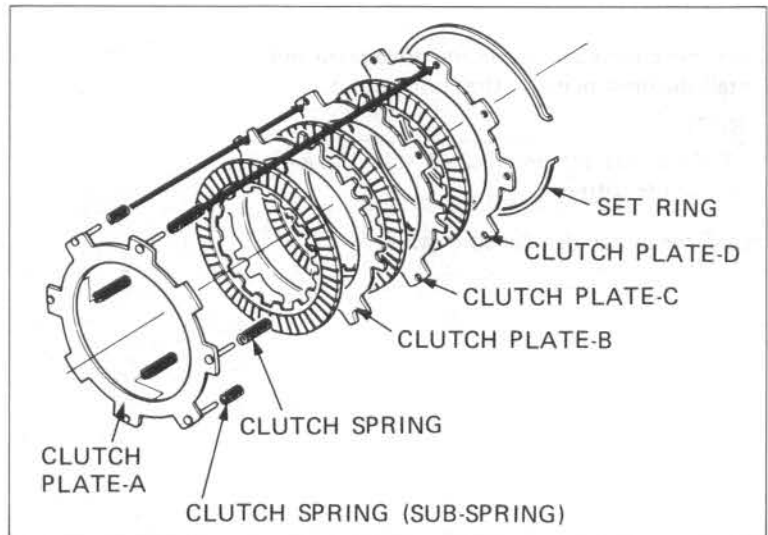

Secure the set ring.

CLUTCH INSTALLATION

Install the spring washer with the dished side facing in.

Install the collar.

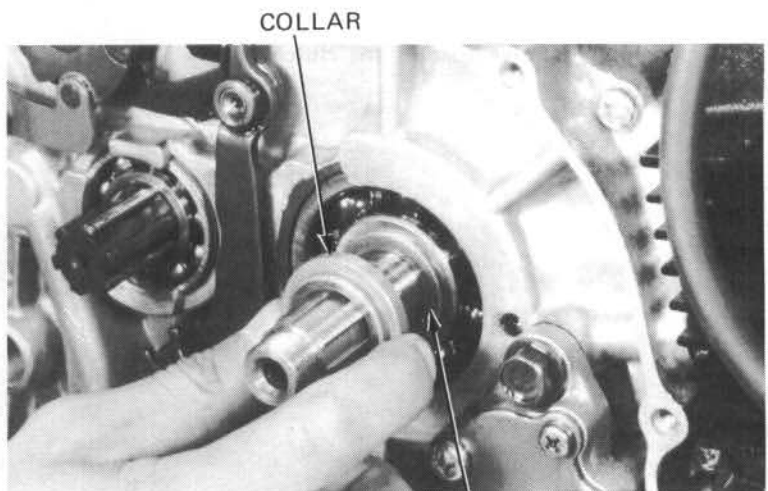

SPRING WASHER

Install the primary driven gear and secure it with the snap ring.



PRIMARY DRIVEN GEAR

SNAP RING

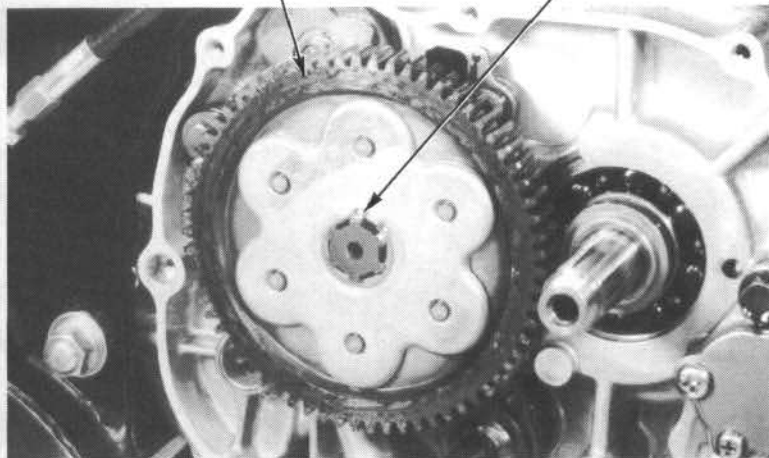

Install the clutch center guide.

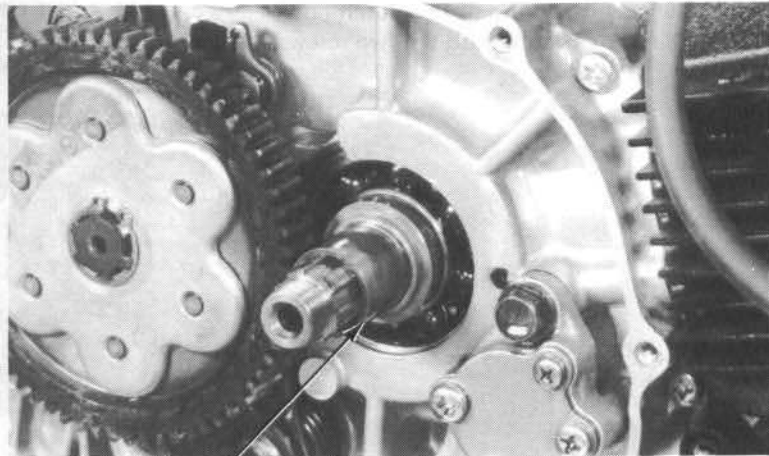
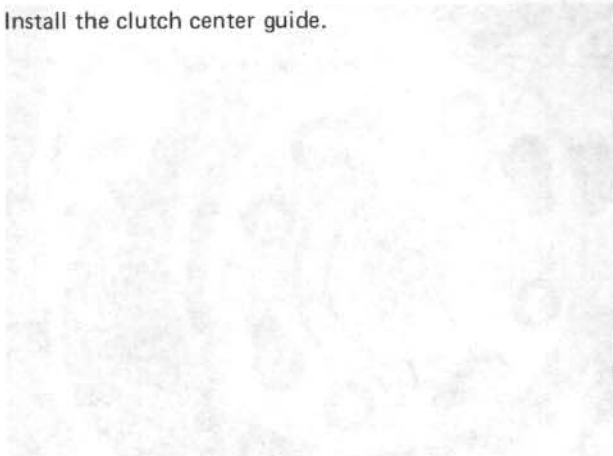

CLUTCH CENTER GUIDE

LOCK NUT WRENCH, 20 x 24 mm
07716-0020100 or
07916-3710000 or
07916-6390000

Install the clutch assembly and the lock washer.

Install and tighten the lock nut.

TORQUE: 40–50 N·m (4.0–5.0 kg-m, 29–36 ft-lb)

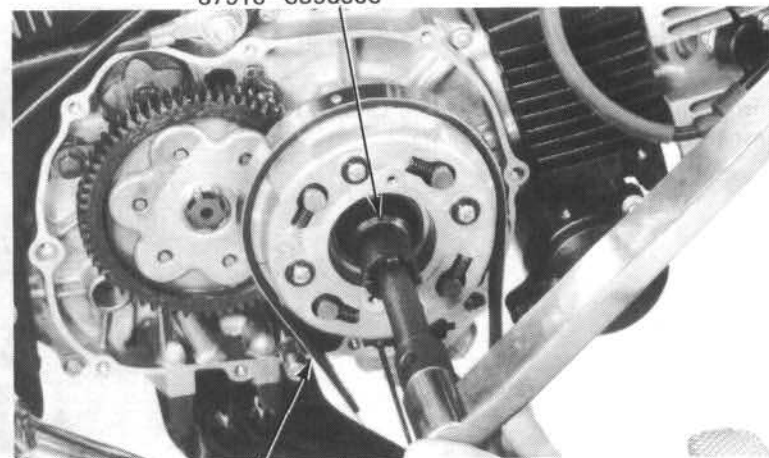
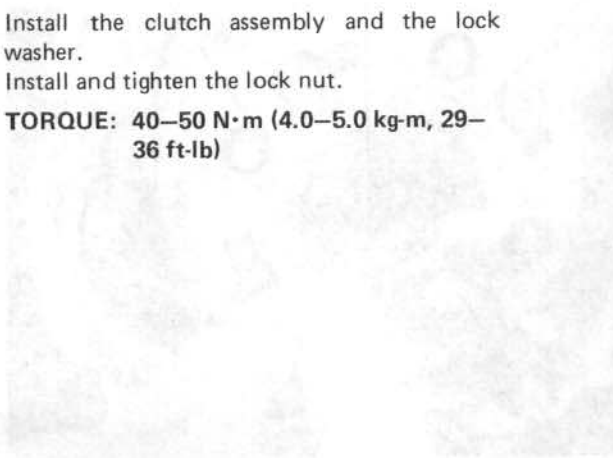

CLUTCH HOLDER 07923-0340000 or FLYWHEEL HOLDER 07725-0040000 or BAND STRAP WRENCH commercially available in U.S.A.

CLUTCH/OIL PUMP

Bend up the lock washer tabs against the lock nut grooves.

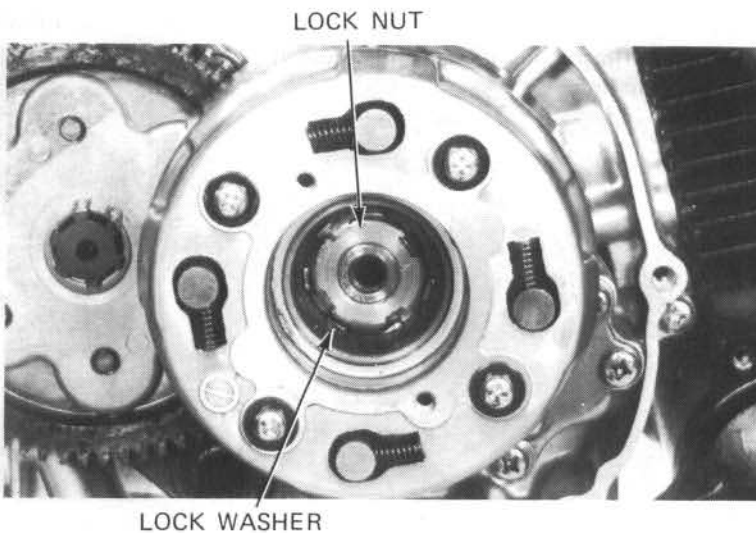

Use a new gasket and install the clutch outer cover and release bearing with the two screws.

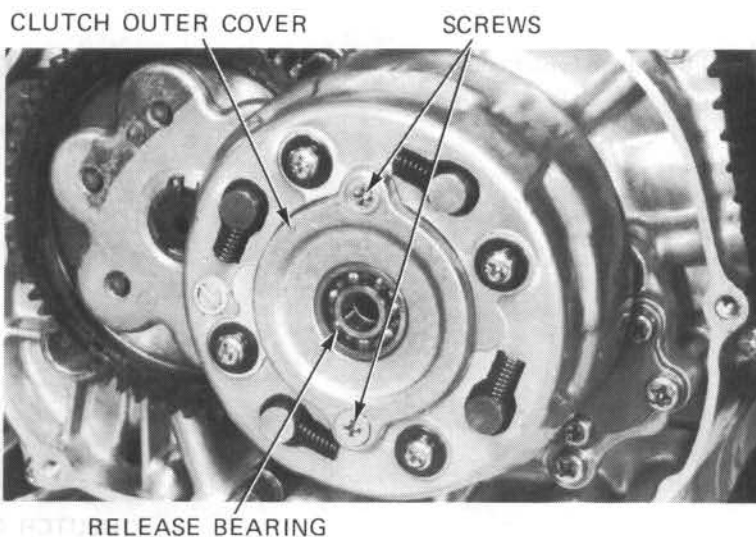

RIGHT CRANKCASE COVER INSTALLATION

Install the clutch lever and clutch cam plate.
Install the oil pass pipe and spring.

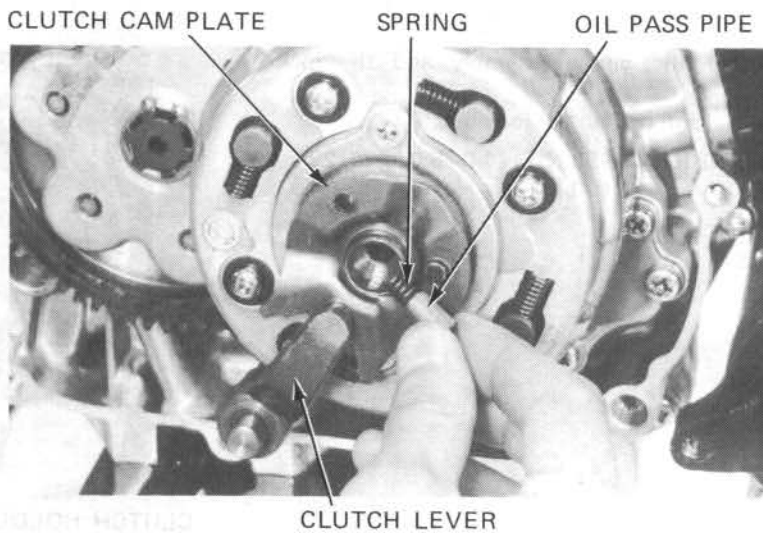

Lean the ATC over to the left to about a 45° angle.
Position the clutch cam plate side spring and ball retainer.
Install the two dowel pins and a new gasket.

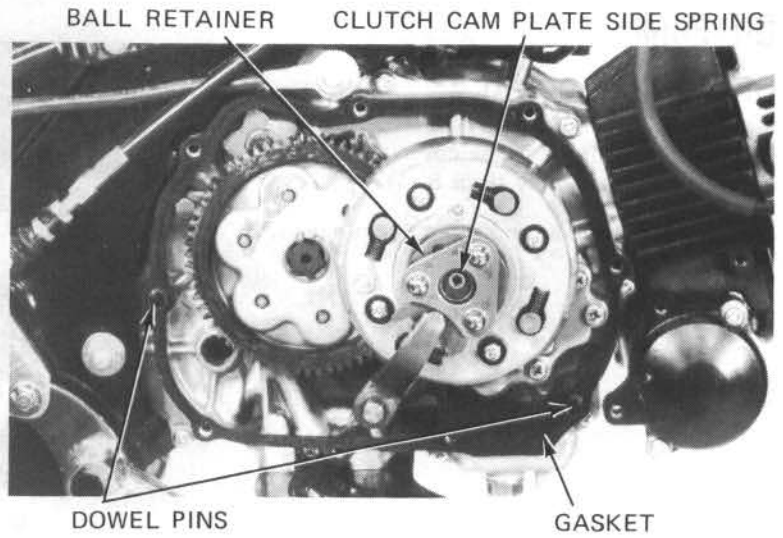

Install the right crankcase cover and starter motor bracket.

Fill the crankcase with the recommended oil (Page 2-1).
Adjust the clutch (Page 3-16).

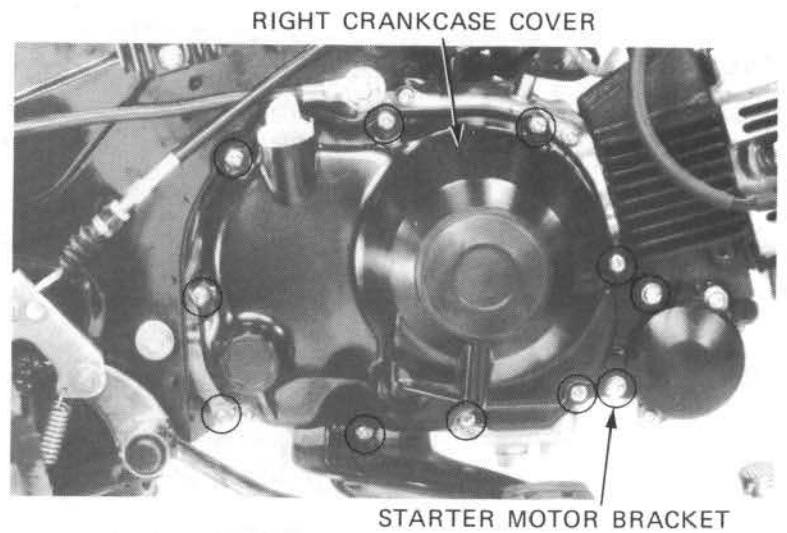

OIL PUMP

OIL PUMP REMOVAL

Remove the right crankcase cover (Page 8-3) and the clutch assembly (Page 8-4).

Remove the hex bolt and three 6 mm screws. Remove the gasket.

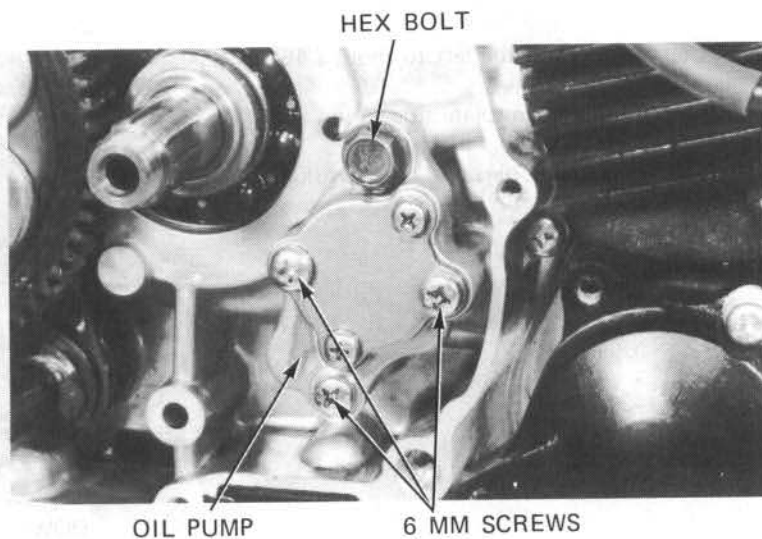

OIL PUMP DISASSEMBLY/ASSEMBLY

Insert the shaft into the inner rotor, aligning the flat on the shaft head with that of the hole.

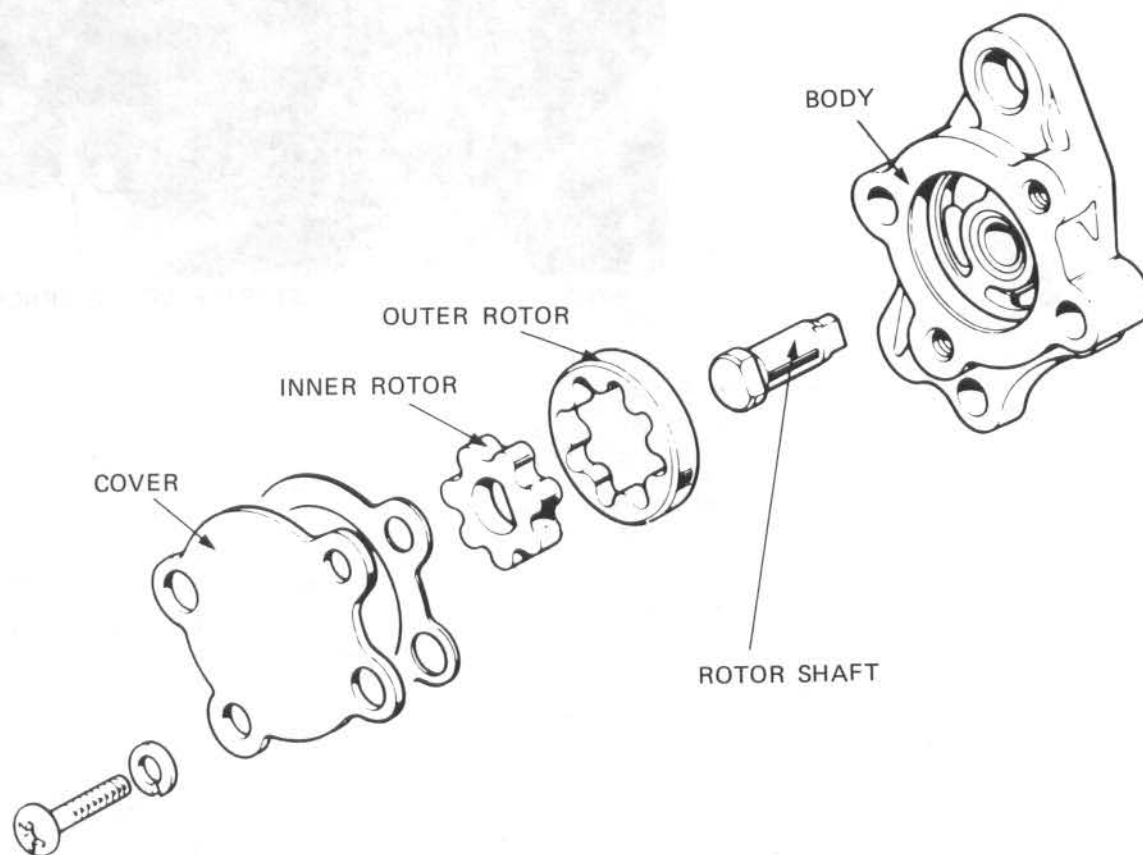

OIL PUMP INSPECTION

Measure the pump body clearance.

SERVICE LIMIT: 0.25 mm (0.010 in)

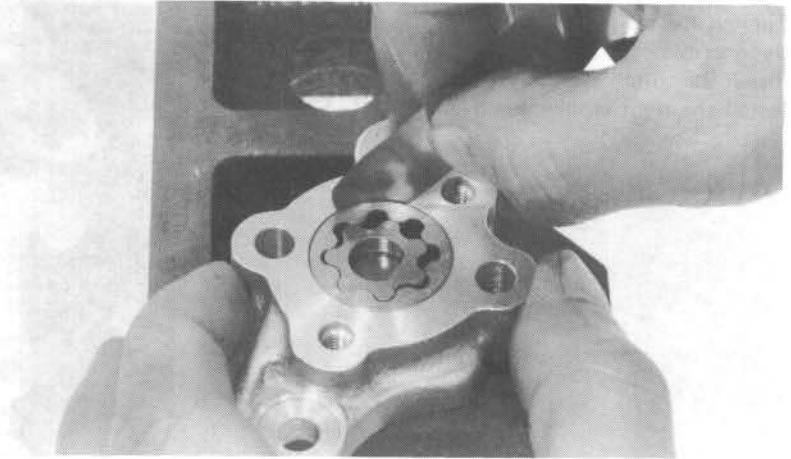

Measure the pump tip clearance.

SERVICE LIMIT: 0.20 mm (0.008 in)

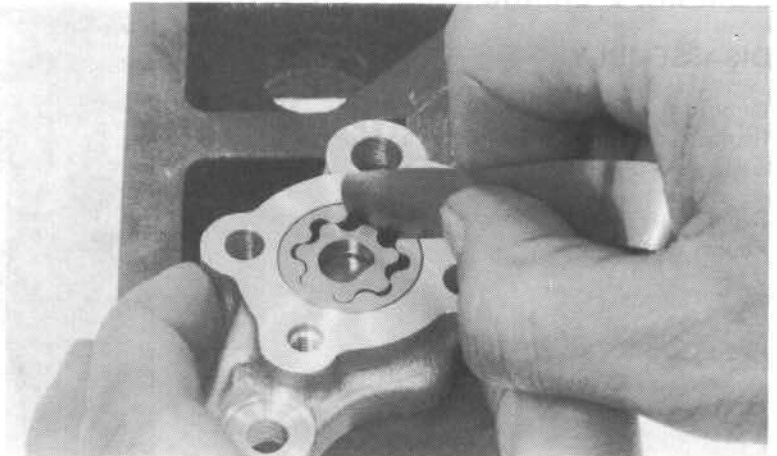

OIL PUMP INSTALLATION

Install the gasket.

Properly fit the flat ends of the oil pump rotor shaft into the recess in the guide roller.



GASKET

OIL PUMP BODY

CLUTCH/OIL PUMP

Tighten the oil pump using the hex. bolt and three screws.

Install the clutch assembly (Page 8-10).

Install the right crankcase cover (Page 8-12).

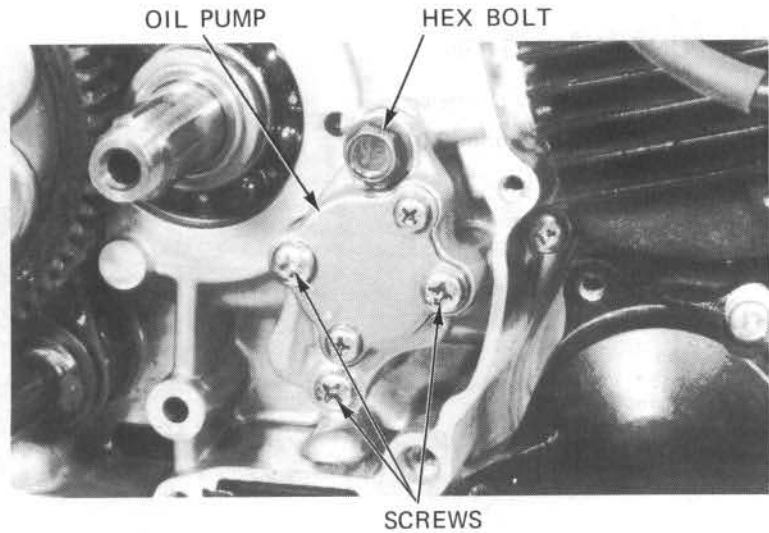

GEARSHIFT LINKAGE

DISASSEMBLY

Remove the right crankcase cover (Page 8-3).
Remove the clutch assembly and primary driven gear (Page 8-4).

Remove the gearshift drum stopper and drum stopper plate.

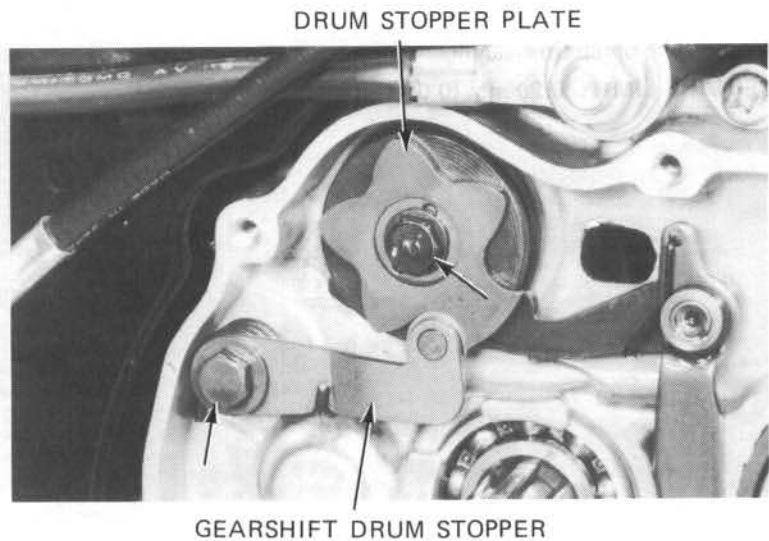

Remove the gearshift pedal.
Disengage the shift arm from the shift drum and pull the gearshift spindle back.

Pull the gearshift spindle out of the crankcase.

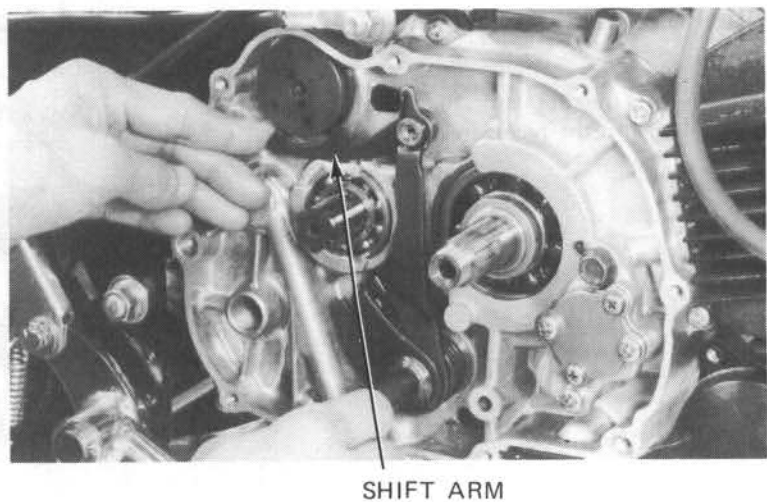

ASSEMBLY

Install the gearshift spindle.

NOTE

- The shift spindle hole in the left crankcase cover has an oil seal. Use care when installing the spindle to avoid damaging it.
- Insert the end of the spring into the shift return spring pin.

Check the gearshift spindle operation.

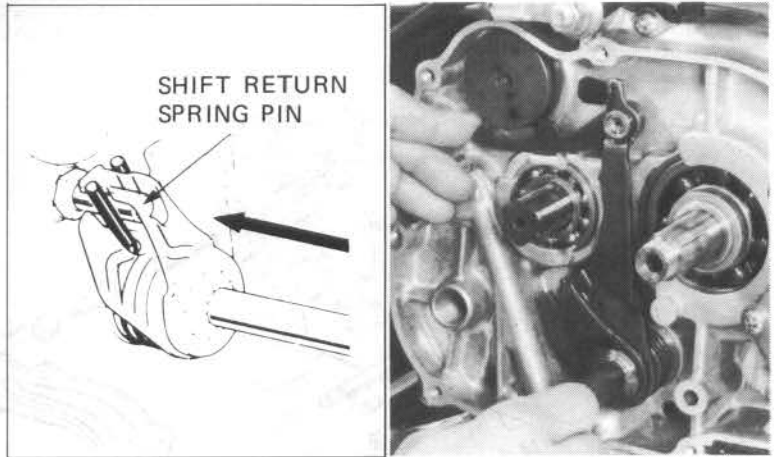

Install the gearshift drum stopper plate by aligning the shift drum pins with the stopper plate holes.

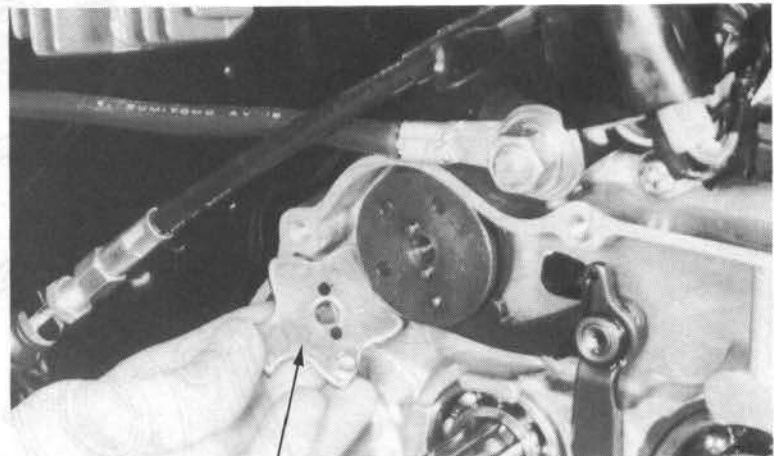

GEARSHIFT DRUM STOPPER PLATE

Tighten the drum stopper plate bolt.

TORQUE: 18–22 N·m (1.8–2.2 kg-m, 13–16 ft-lb)

Install the gearshift drum stopper.

NOTE

- Before tightening the bolt, make sure that the stopper is positioned properly.

Install the gearshift pedal and check the operation of the gearshift linkage.
Install the primary driven gear and clutch assembly (Page 8–10).

Install the right crankcase cover (Page 8–12).

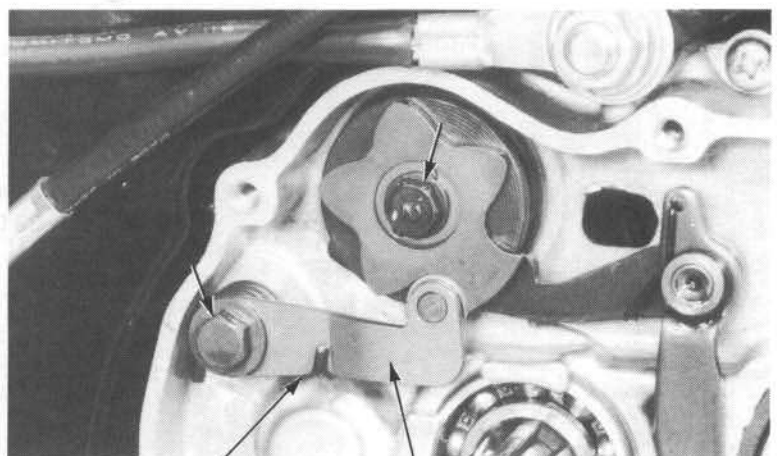

SPRING GEARSHIFT DRUM STOPPER

RECOIL STARTER/ALTERNATOR/CAM CHAIN TENSIONER

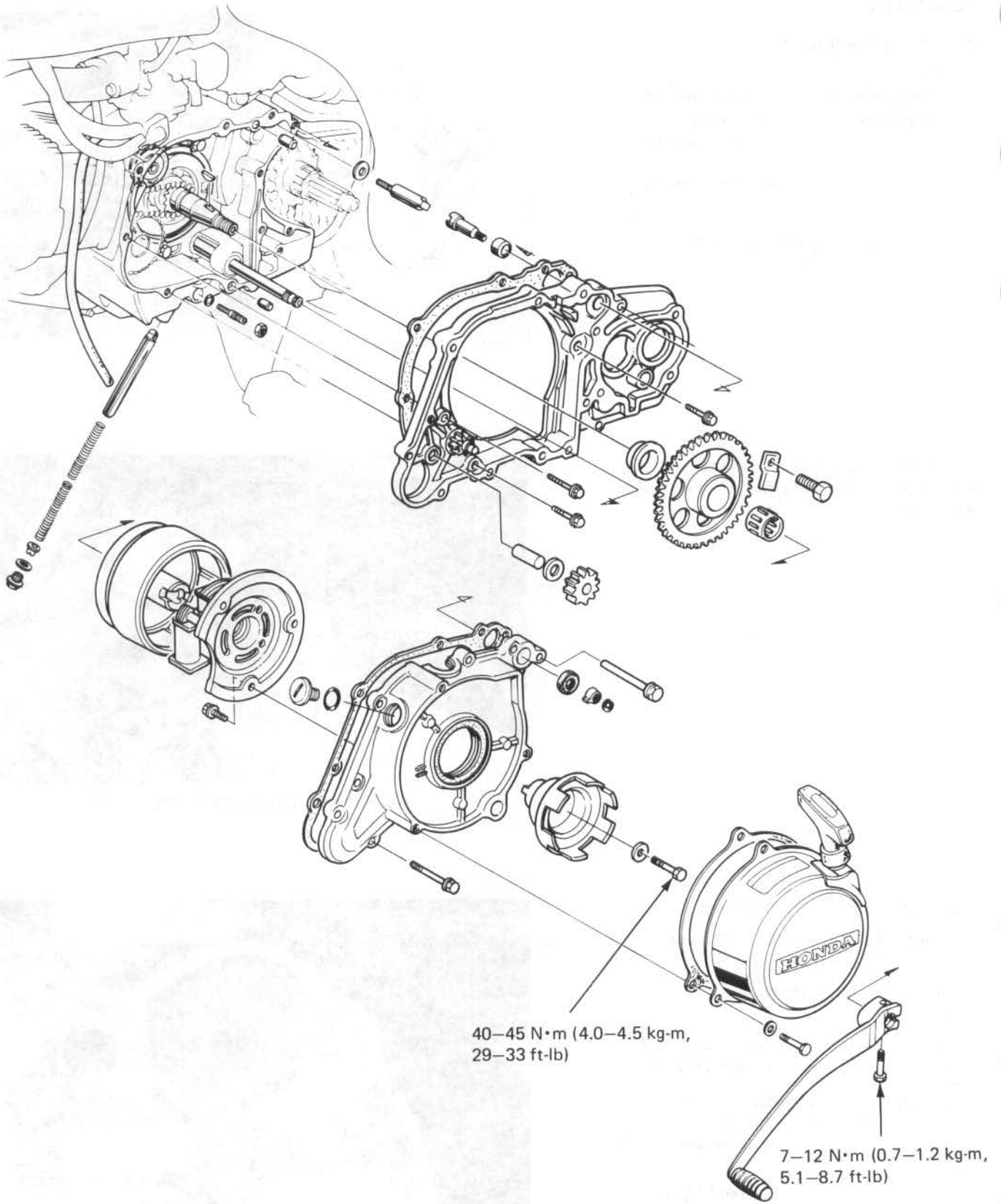

9. RECOIL STARTER/ALTERNATOR/ CAM CHAIN TENSIONER

SERVICE INFORMATION	9-1
TROUBLESHOOTING	9-1
RECOIL STARTER	9-2
ALTERNATOR	9-6
STARTER GEARS	9-10
CAM CHAIN TENSIONER	9-14

SERVICE INFORMATION

GENERAL

- This section covers removal and installation of the recoil starter and alternator.
- For alternator inspection and troubleshooting, refer to section 15.

SPECIFICATIONS

ITEM				STANDARD		SERVICE LIMIT	
Cam chain tensioner	'84	Free length	A	65 mm	(2.6 in)	60 mm	(2.4 in)
			B	49.8 mm	(1.96 in)	40 mm	(1.6 in)
spring	After '84	Free length		83.0 mm	(3.27 in)	77 mm	(3.0 in)

TORQUE VALUE

Starter driven pulley bolt 40-45 N·m (4.0-4.5 kg-m, 29-33 ft-lb)

TOOLS

Common

Flywheel Puller
Flywheel Holder

07733-0010000 (or 07933-2000000)
07725-0040000 (or band strap wrench commercially available in U.S.A.)

TROUBLESHOOTING

Engine does not turn when operating recoil starter

1. Faulty starter ratchet
2. Faulty starter driven pulley
3. Faulty starter drive pulley

Starter rope does not recoil

- Faulty recoil spring

RECOIL STARTER

REMOVAL

- Shift the transmission into neutral.
- Remove the gearshift pedal.
- Remove the recoil starter and gasket.

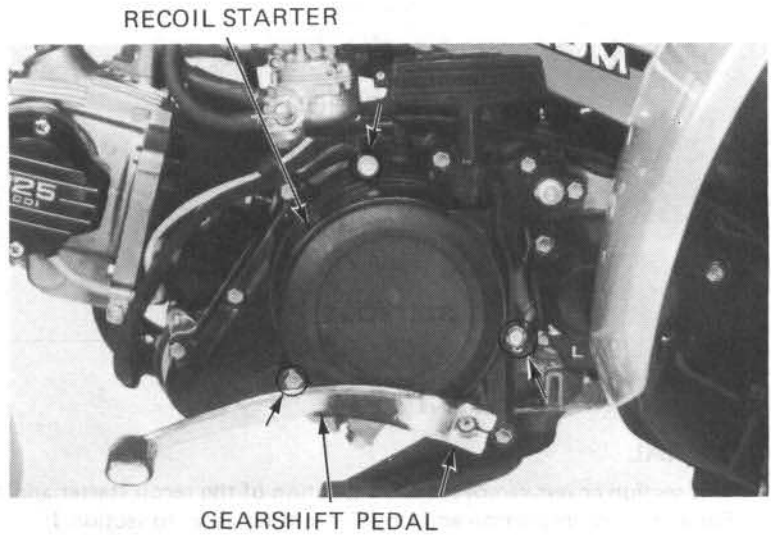

DISASSEMBLY

- Remove the nut attaching the ratchet cover and cover.

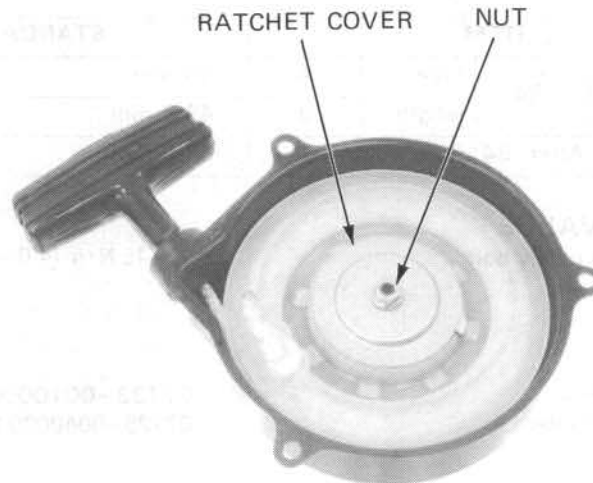

- Remove the ratchet, ratchet guide, spring seat and spring.
- Check the ratchet, ratchet guide and spring for wear or damage.

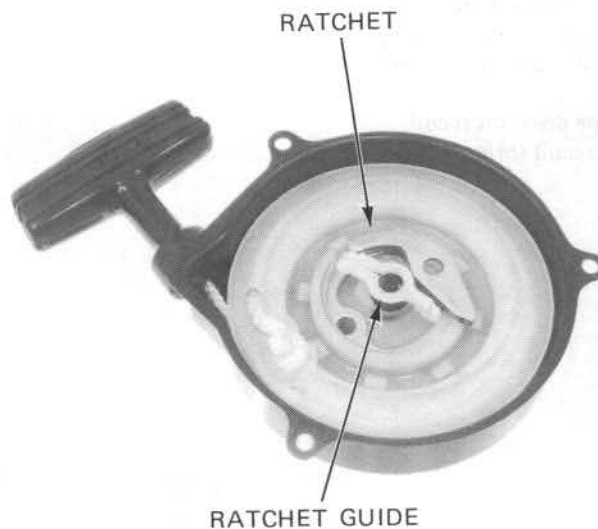

Remove the starter handle cover.
Unwind the starter rope and remove the starter handle.
Release the starter rope slowly.
Remove the starter drive pulley.

CAUTION

Wear eye protection and use care when removing the drive pulley and starter spring. The spring can pop out of the housing if care is not used.

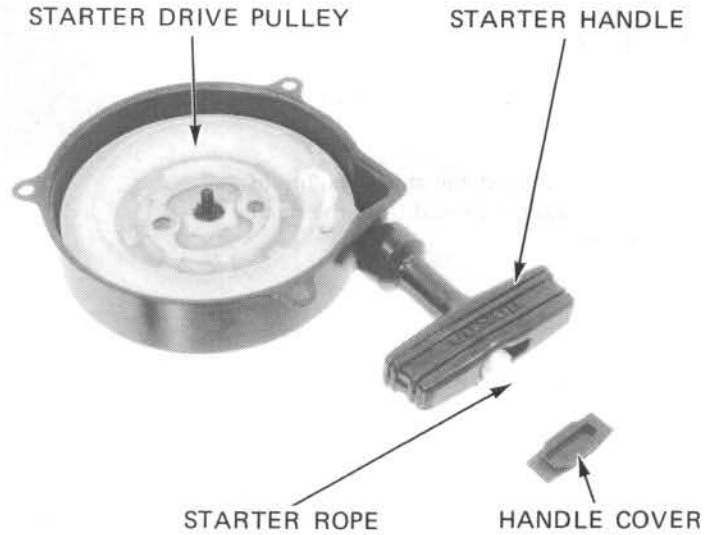

Remove the starter rope from the drive pulley.
Check the starter rope for wear or damage.

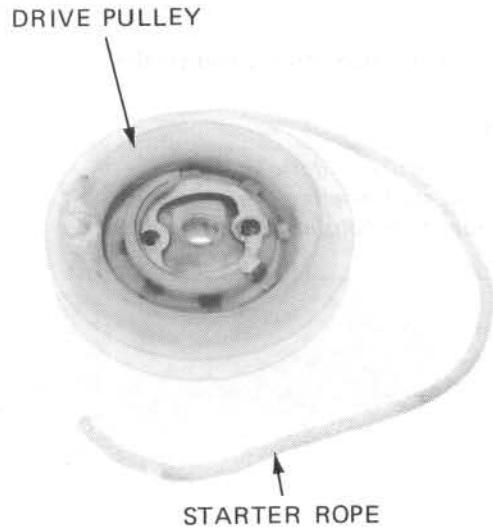

Check the recoil starter spring.
Remove the spring if it is broken.

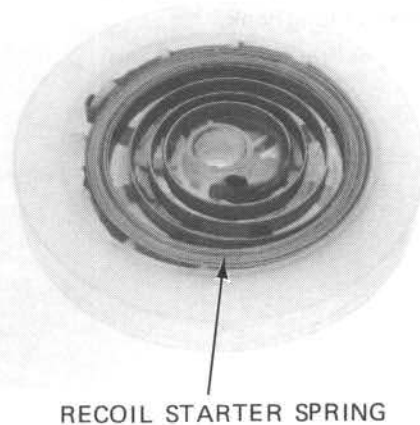

RECOIL STARTER/ALTERNATOR/CAM CHAIN TENSIONER

ASSEMBLY

Install the starter rope and tie a square knot in the end.

Wrap the rope around the starter pulley in a clockwise direction as viewed from the ratchet side as shown.

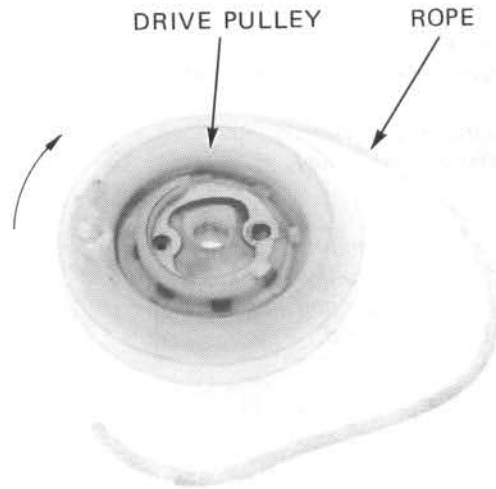

Install the spring by hooking the end on the drive pulley hook.

CAUTION

Wear eye protection and use care when installing the starter spring. The spring can pop out of the housing if care is not used.

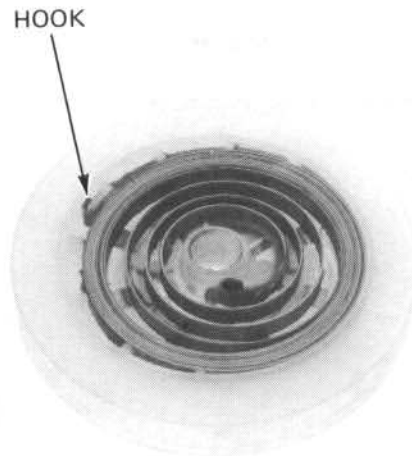

Apply grease to the pulley shaft and install the drive pulley by hooking the end of the spring on the starter housing hook.

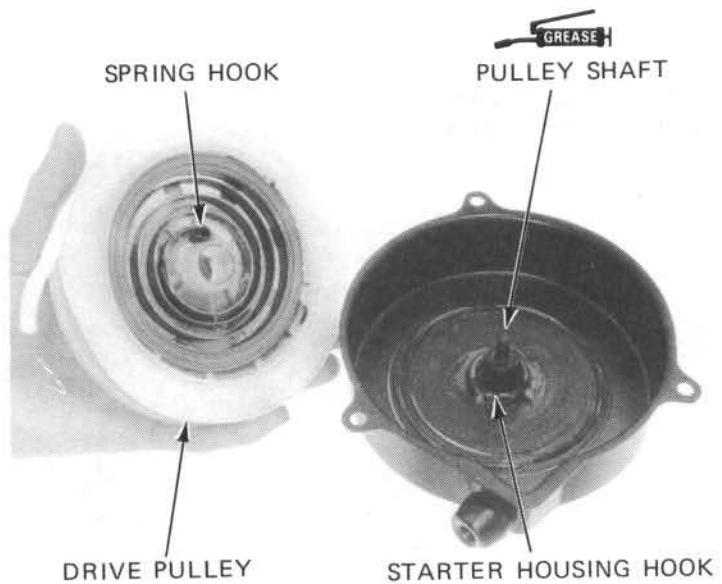

Preload the starter spring by turning the pulley 2 turns clockwise.

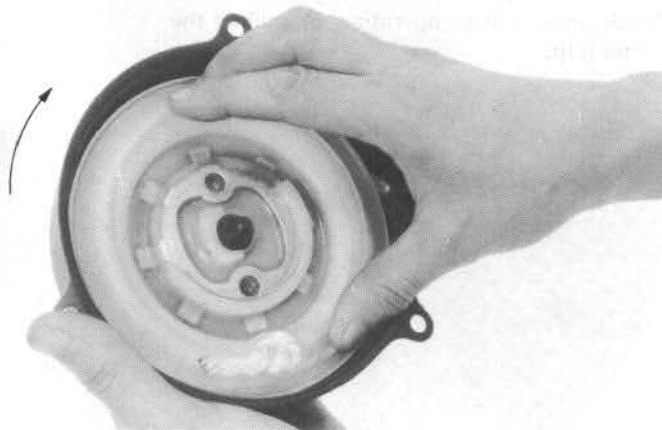

Route the rope end through the starter housing hole and install the handle.

Tie the rope end and install the handle cover.

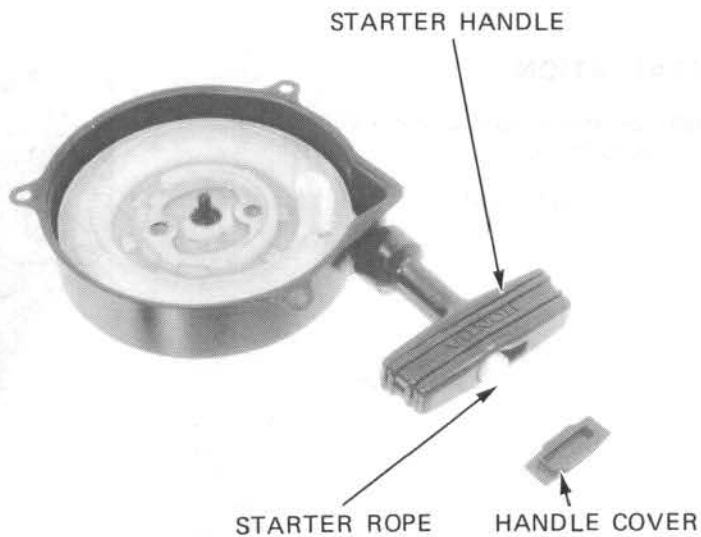

Apply grease to the ratchet and install the ratchet onto the drive pulley. Install the spring, spring seat and ratchet guide.

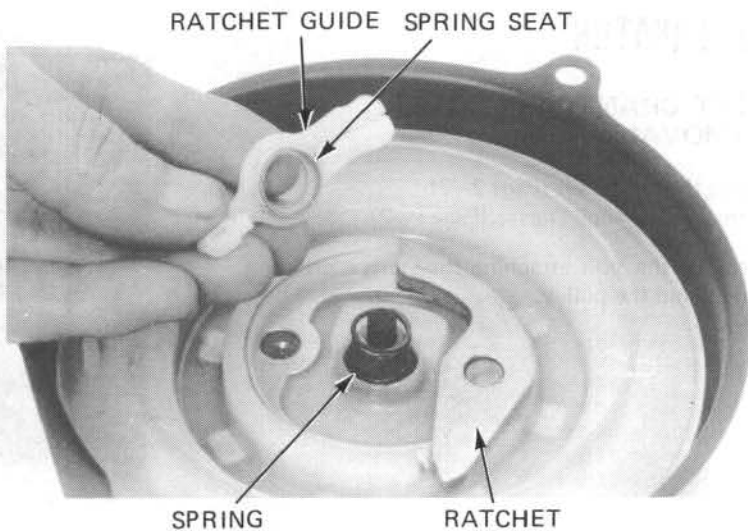

RECOIL STARTER/ALTERNATOR/CAM CHAIN TENSIONER

Install the ratchet cover and tighten the nut. Check recoil starter operation by pulling the starter grip.

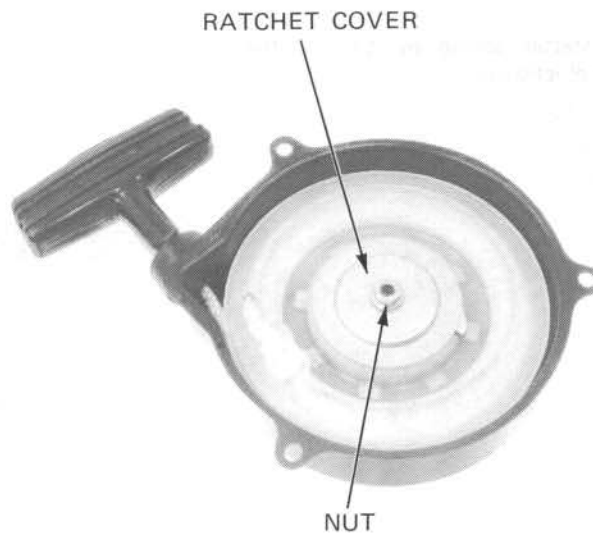

INSTALLATION

Install the starter gasket and recoil starter with three bolts.

Install the gearshift pedal.

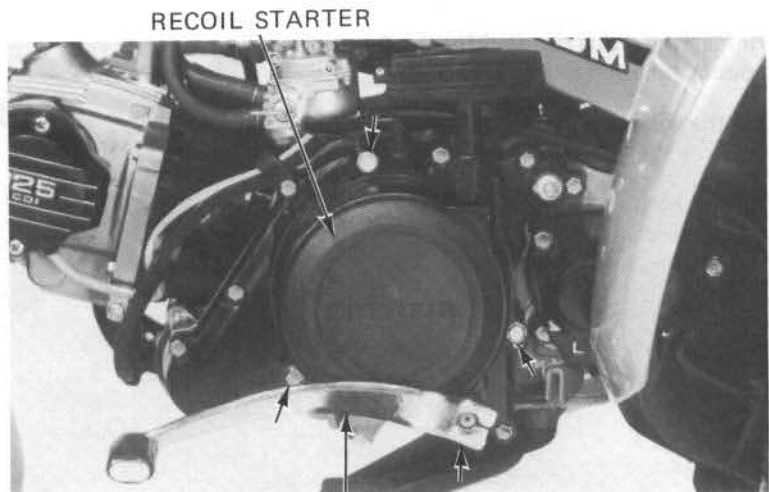

ALTERNATOR

LEFT CRANKCASE COVER REMOVAL

Drain the engine oil (Page 2-2).
Remove the recoil starter (Page 9-2).

Remove the bolt attaching the starter driven pulley and the pulley.

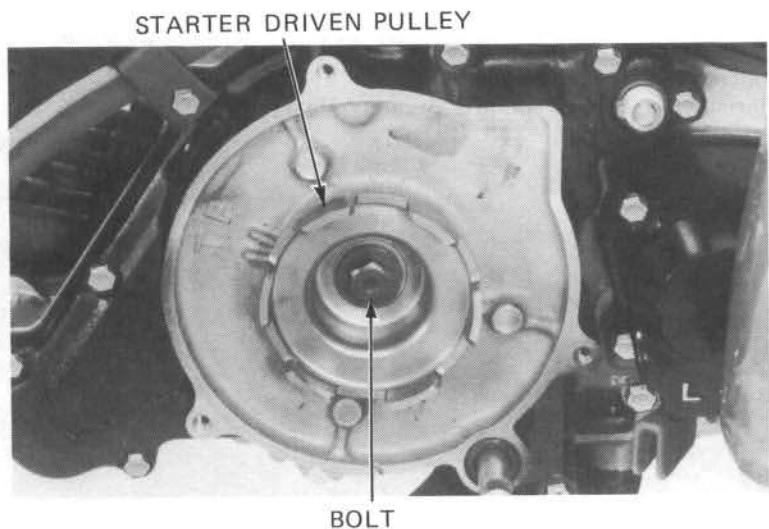

Remove the E-clip attaching the neutral indicator and the indicator.
Disconnect the alternator coupler.

Remove the eleven screws attaching the left crankcase cover and the cover.
Remove the two dowel pins and gasket.

LEFT CRANKCASE COVER NEUTRAL INDICATOR

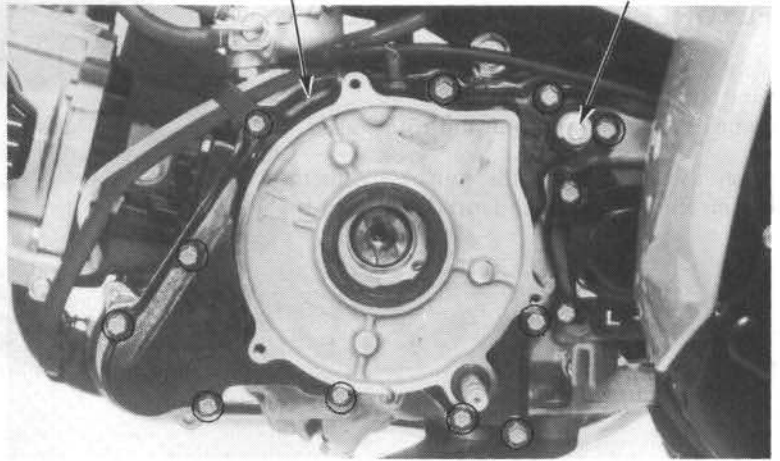

Check the seals on the left crankcase cover and replace if necessary.

SEALS

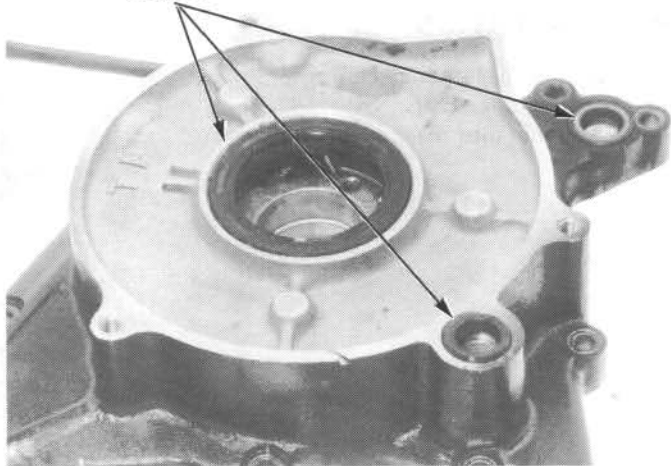

STATOR REMOVAL

Remove the three bolts mounting the stator and the stator from the left crankcase.

BOLTS

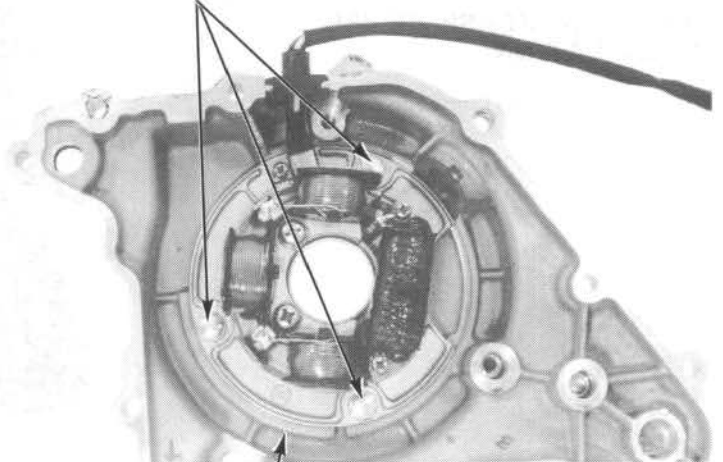

STATOR

FLYWHEEL HOLDER 07725-0040000 OR BAND STRAP WRENCH (commercially available in U.S.A.)

FLYWHEEL REMOVAL/INSTALLATION

Hold the flywheel with the flywheel holder or band strap wrench.

Remove the flywheel with the rotor puller.

Align the key way in the flywheel with the key on the crankshaft and install the flywheel.

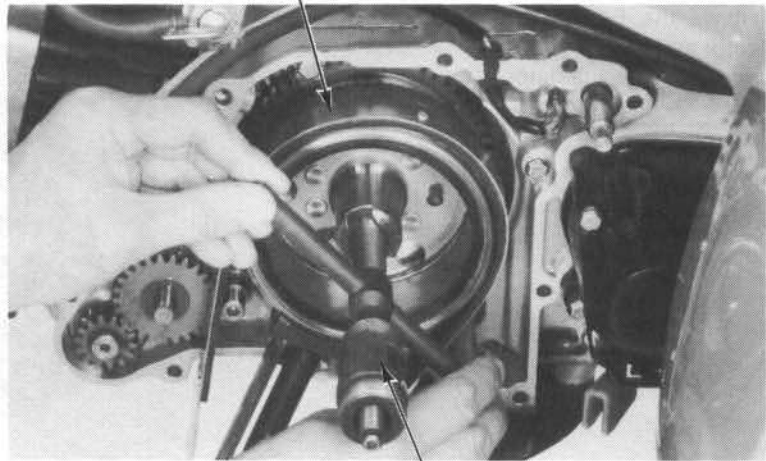

FLYWHEEL PULLER 07733-0010000 or 07933-2000000

STATOR INSTALLATION

Install the stator onto the left crankcase cover and tighten it with the three bolts.

Insert the wire grommet into the groove in the left crankcase cover.

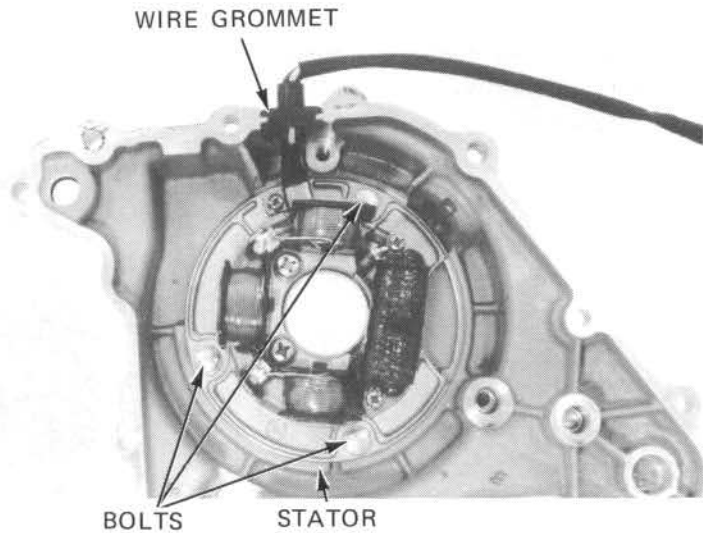

LEFT CRANKCASE COVER INSTALLATION

Install the two dowel pins and new gasket.

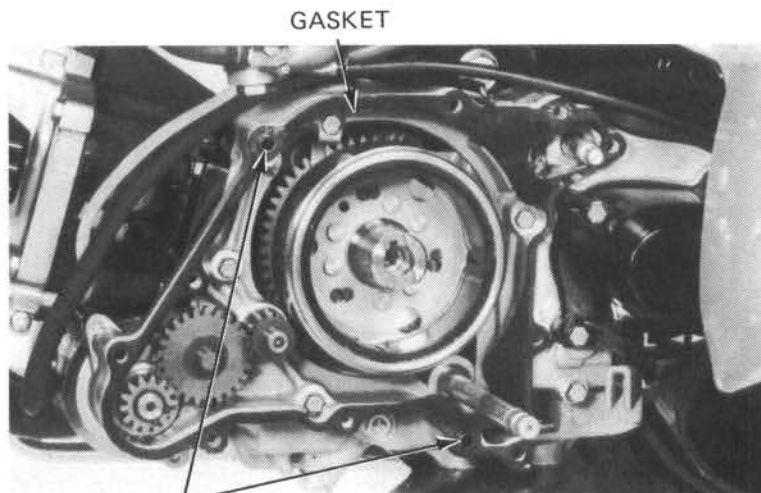

Install the left crankcase cover using the eleven screws.
 Make sure that the transmission is in neutral and install the neutral indicator and E-clip.
 Connect the alternator coupler to the wire harness.

LEFT CRANKCASE COVER NEUTRAL INDICATOR

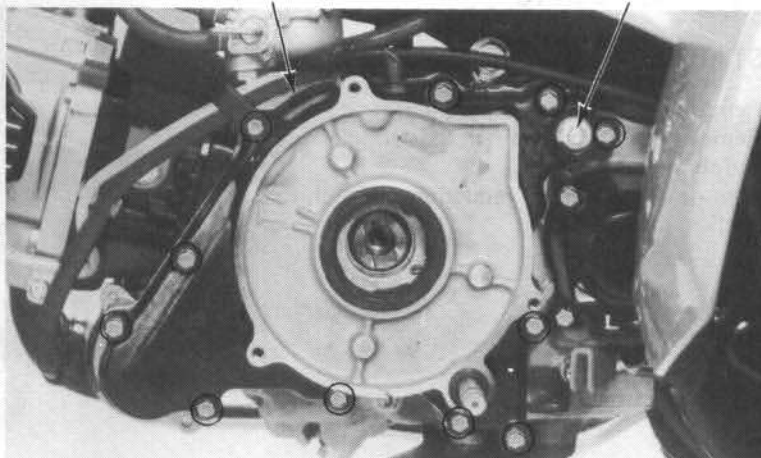

Apply grease to the oil seal lip and install the starter driven pulley by aligning its flats with the groove in the flywheel.

GREASE GROOVE

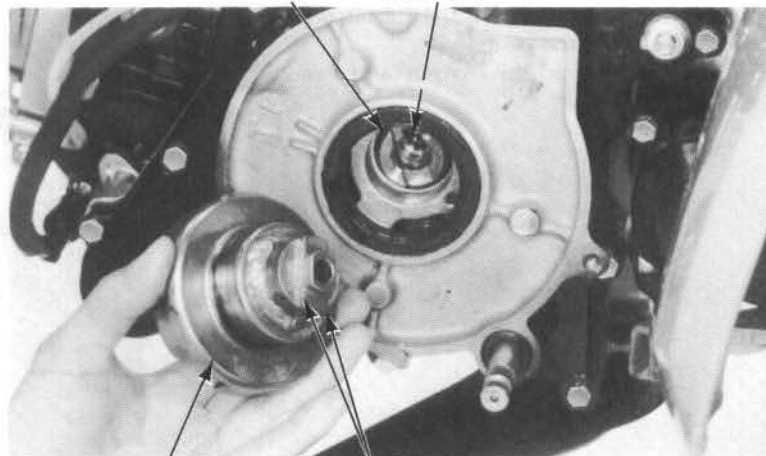

STARTER DRIVEN PULLEY FLATS

Install the pulley bolt, washer and O-ring.
 Hold the driven pulley with a suitable tool and tighten the bolt.

TORQUE: 40–45 N·m (4.0–4.5 kg-m,
 29–33 ft-lb)

Install the recoil starter (Page 9–6).
 Fill the crankcase with the recommended oil (Page 2–1).

STARTER DRIVEN PULLEY

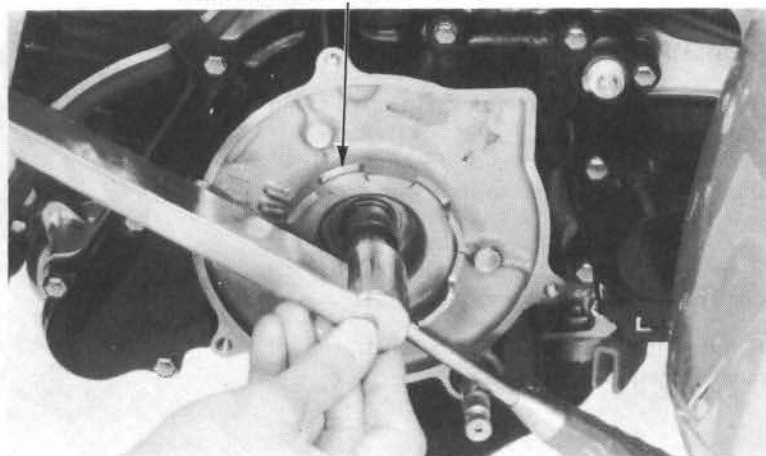

STARTER GEARS

STARTER GEAR REMOVAL

Remove the alternator (Page 9-6).
 Remove the thrust washer, starter idler gear and shaft.
 Remove the starter reduction gear thrust washer.

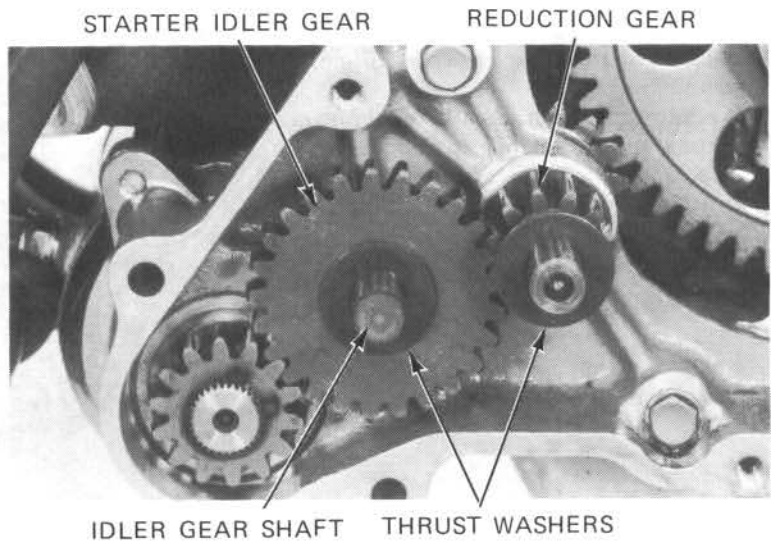

Remove the bolt attaching the starter driven gear set plate and the plate.
 Remove the starter driven gear and needle bearing.

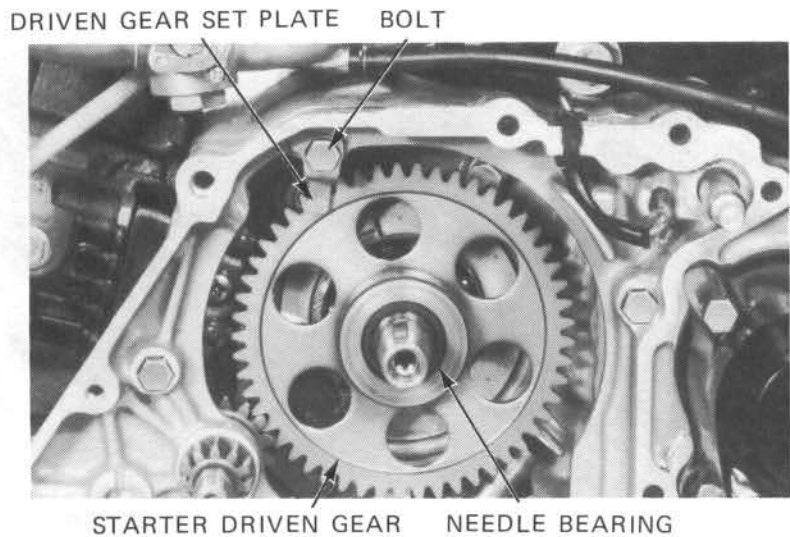

LEFT CRANKCASE COVER SPACER REMOVAL

Remove the left rear wheel and drive chain cover (Section 13).
 Remove the sub-transmission (Section 10).
 Disconnect the neutral switch wire from the switch.

Remove the four bolts mounting the left crankcase cover spacer and the spacer.

Remove the neutral indicator shaft, dowel pins and gasket.

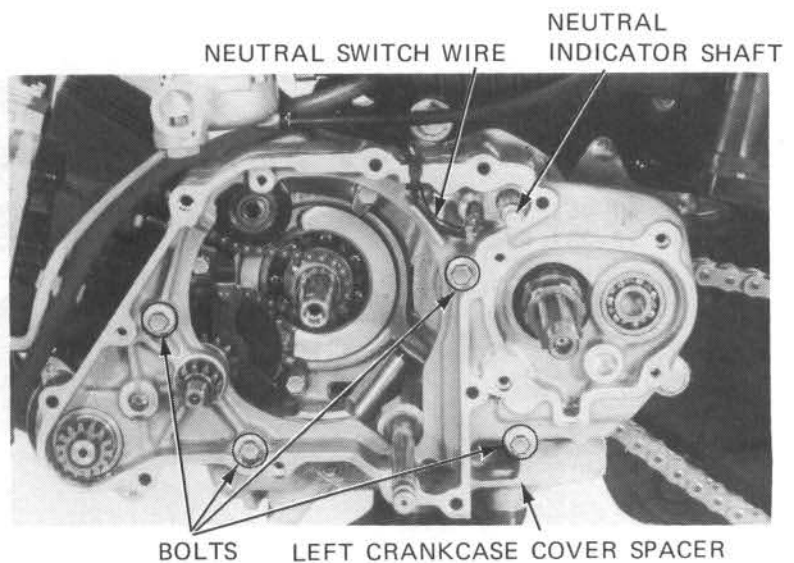

Remove the snap ring securing the starter reduction gears and the gears and thrust washers from the left crankcase cover spacer.

LEFT CRANKCASE COVER SPACER SNAP RING

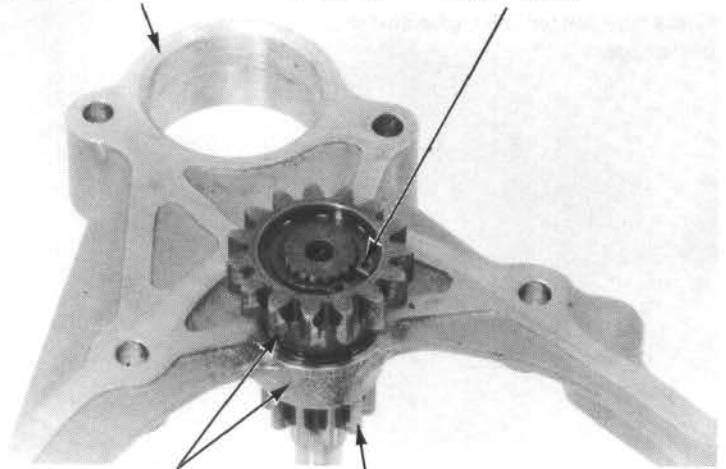

THRUST WASHERS REDUCTION GEARS

STARTER GEAR INSPECTION

Remove the one way clutch rollers, plungers and springs from the flywheel and check them for wear or damage.

FLYWHEEL

SPRING

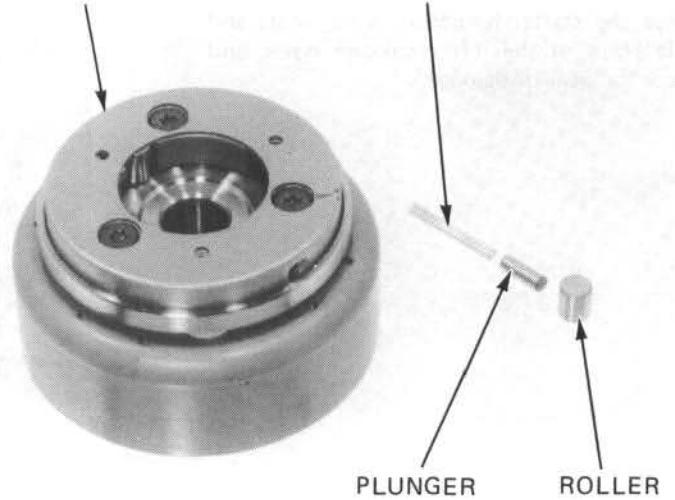

PLUNGER

ROLLER

Check the starter driven gear for wear or damage.

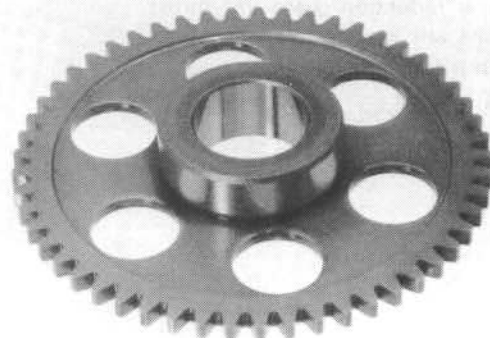

RECOIL STARTER/ALTERNATOR/CAM CHAIN TENSIONER

Check the starter idler gear and shaft for wear or damage.

STARTER IDLER GEAR

SHAFT

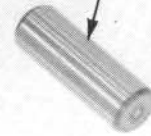
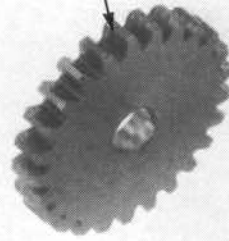

Check the starter reduction gears, shaft and shaft bores in the left crankcase cover and spacer for wear or damage.

LEFT CRANKCASE COVER SPACER

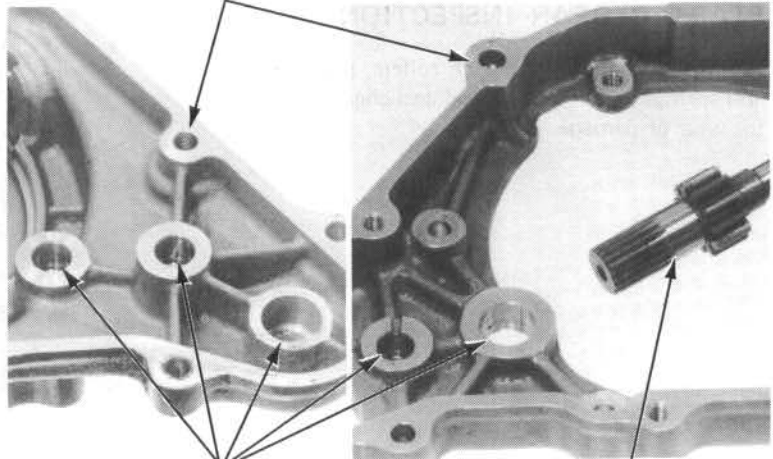

BORES

REDUCTION GEAR SHAFT

LEFT CRANKCASE COVER SPACER INSTALLATION

Install the starter reduction gears and thrust washers onto the left crankcase cover spacer and secure them with the snap ring.

SNAP RING

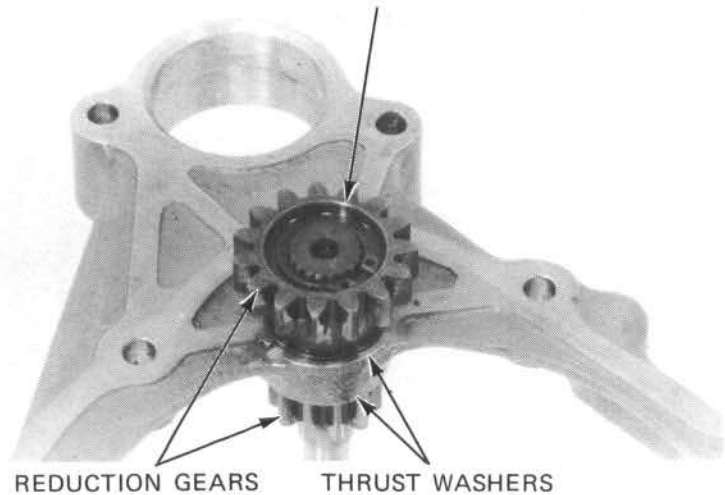

REDUCTION GEARS

THRUST WASHERS

Install the dowel pins and new gasket onto the left crankcase.
Install the neutral indicator shaft.

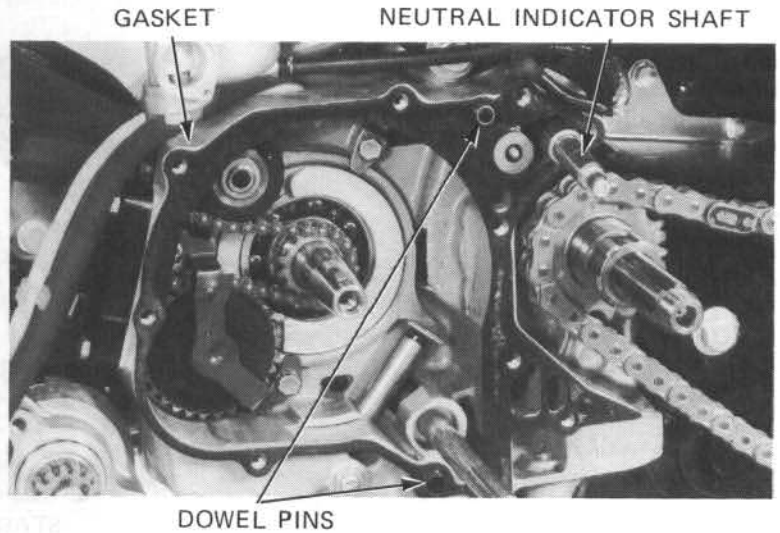

Install the left crankcase cover spacer and tighten it with the four bolts.
Connect the neutral switch wire to the switch.
Install the sub-transmission (Section 10).

Install the drive chain cover and left rear wheel (Section 13).

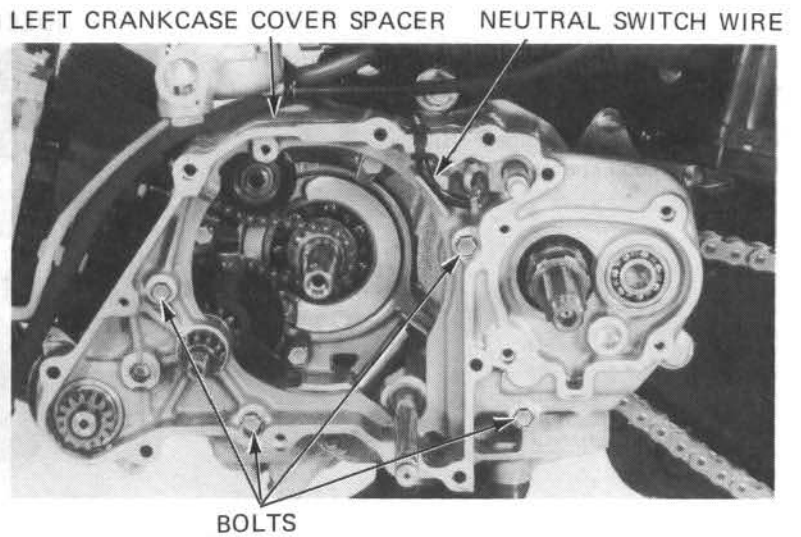

STARTER GEAR INSTALLATION

Install the starter driven gear spacer over the crankshaft.

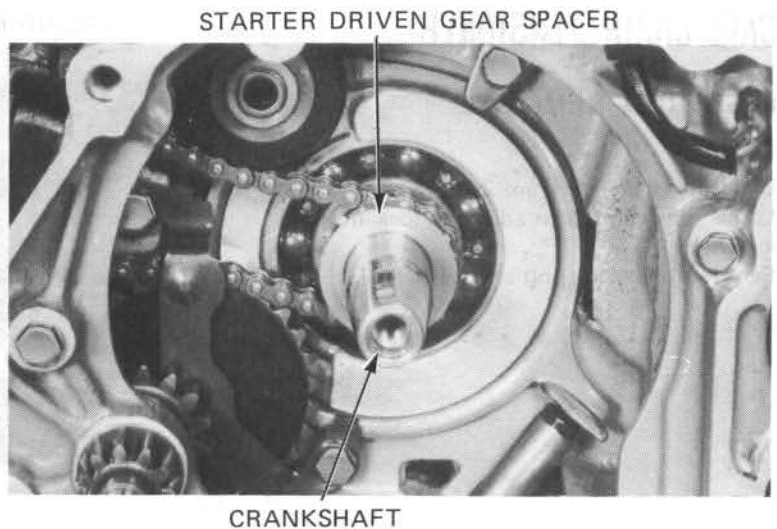

RECOIL STARTER/ALTERNATOR/CAM CHAIN TENSIONER

Install the starter driven gear and needle bearing.
Install the driven gear set plate using the bolt.

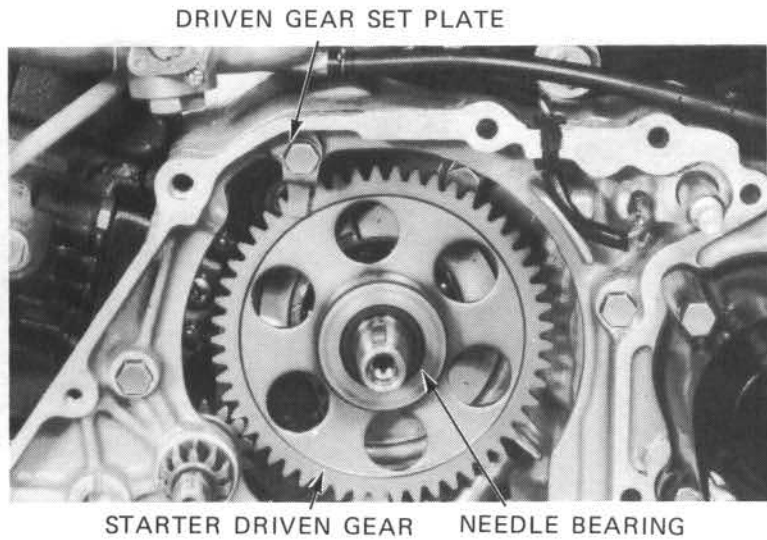

Install the starter idler gear, shaft and thrust washers.

Install the alternator (Page 9-8).
Install the recoil starter (Page 9-6).

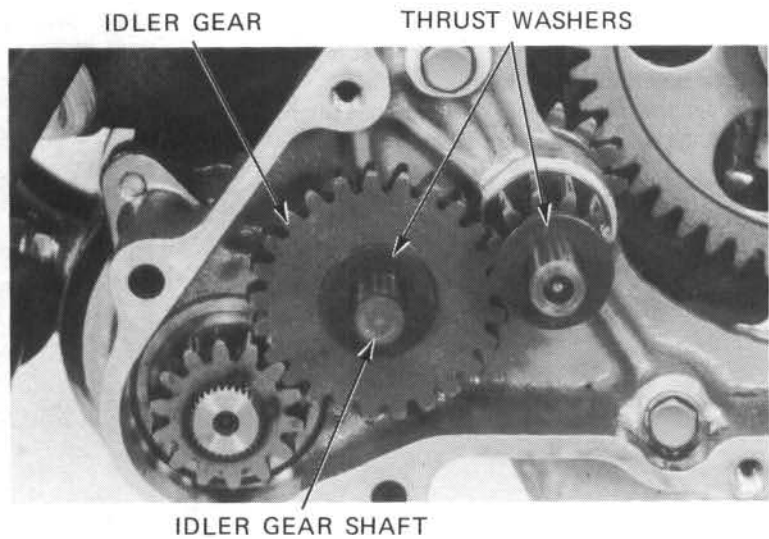

CAM CHAIN TENSIONER

PUSH ROD REMOVAL

'84:
Drain the engine oil (Page 2-2).
Loosen the cam chain adjusting lock nut and screw.
Remove the sealing bolt and washer.

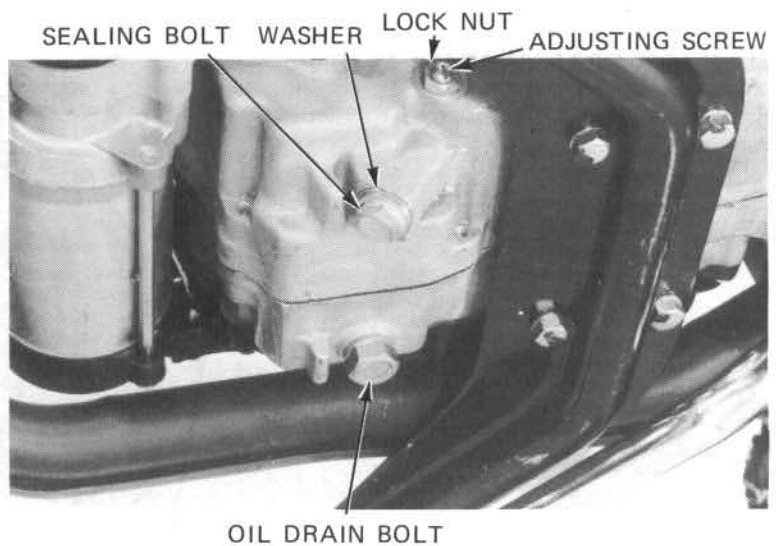

Remove the adjusting screw, tensioner spring A and B and push rod.

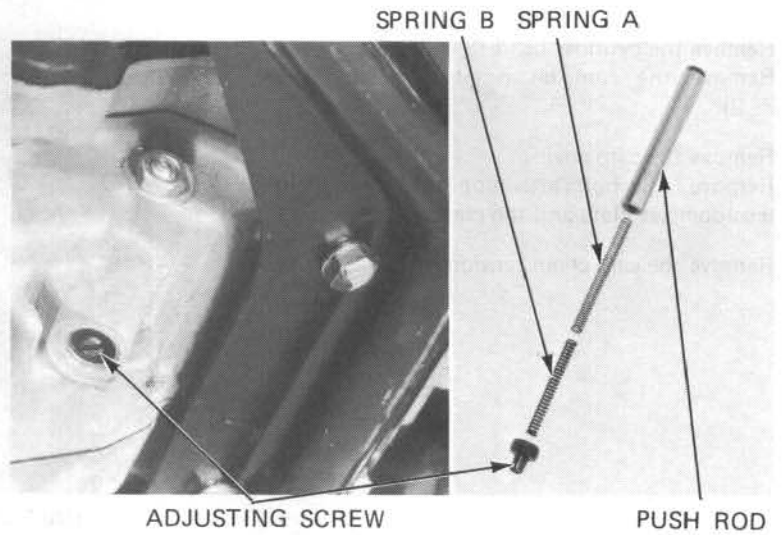

After '84:
 Drain the engine oil (Page 2-2).
 Remove the sealing bolt and washer.
 Remove the tensioner spring and push rod.

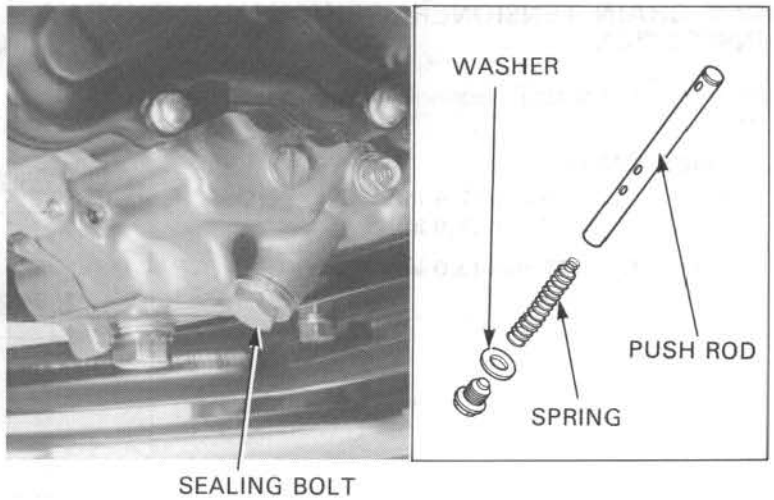

TENSIONER REMOVAL

Remove the left crankcase cover spacer (Page 9-10).
 Remove the two bolts attaching the guide sprocket set plate and the plate and guide sprocket.

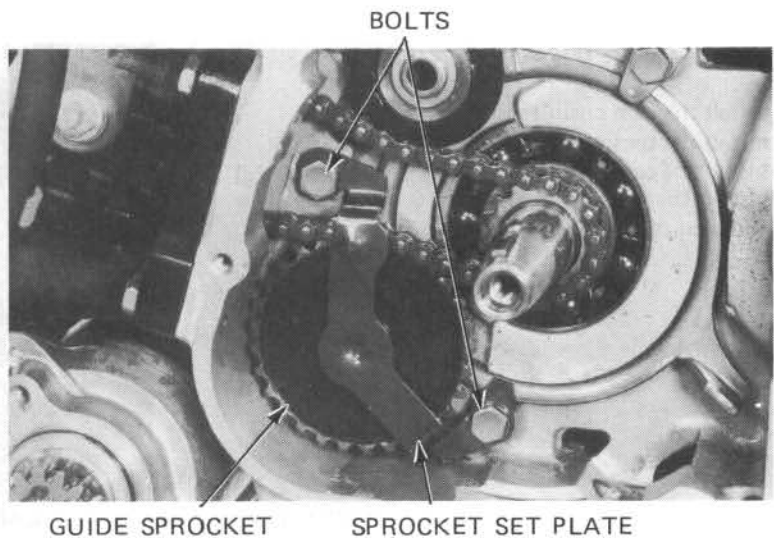

RECOIL STARTER/ALTERNATOR/CAM CHAIN TENSIONER

Remove the cylinder head (Section 6).
Remove the cam chain guide roller (Page 7-2).

Remove the cam chain.
Remove the bolt attaching the cam chain tensioner set plate and the plate.

Remove the cam chain tensioner.

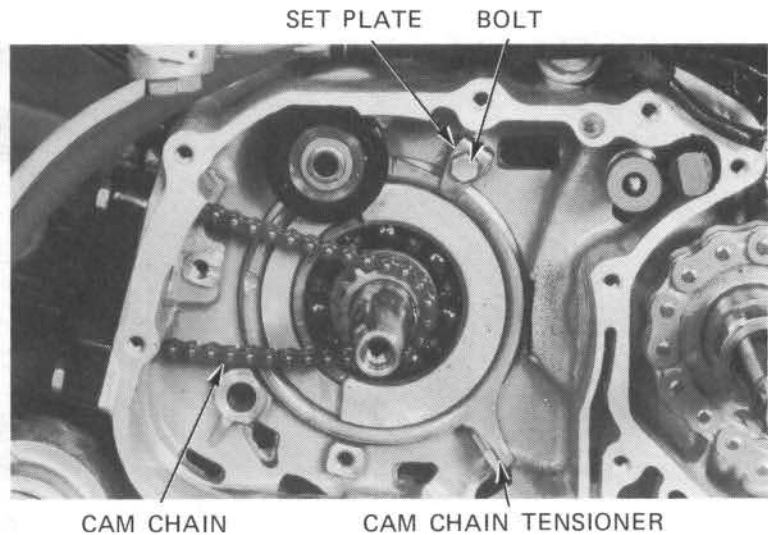

CAM CHAIN TENSIONER SPRING INSPECTION

Measure the cam chain tensioner spring free lengths.

SERVICE LIMITS:

'84: A	60 mm (2.4 in)
B	40 mm (1.6 in)
After '84:	77 mm (3.0 in)

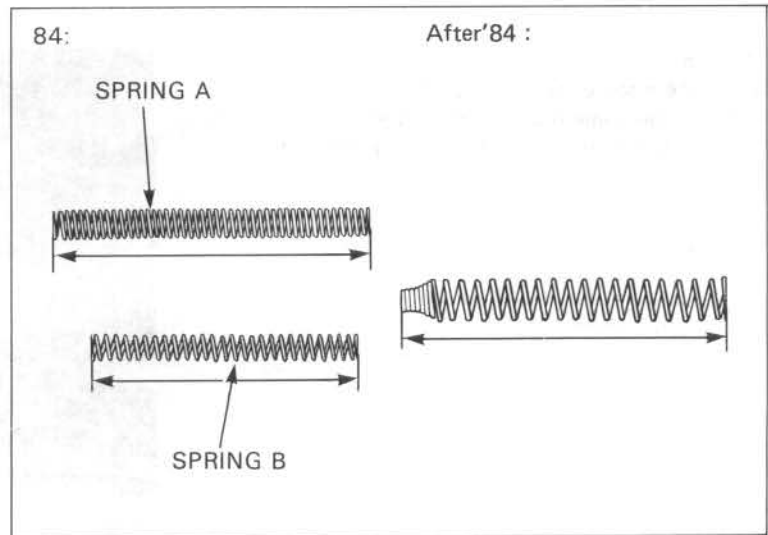

TENSIONER INSTALLATION

Install the cam chain tensioner.
Install the tensioner set plate with the bolt.
Install the cam chain.
Install the tensioner guide roller (Page 7-7) and cylinder head (Section 6).

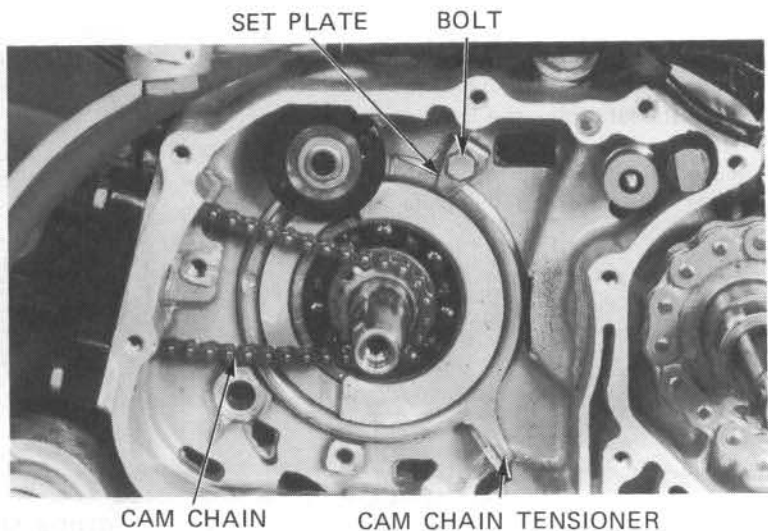

Apply grease to the guide sprocket journals and insert the guide sprocket into the crankcase aligning its groove with the oil pump drive shaft.

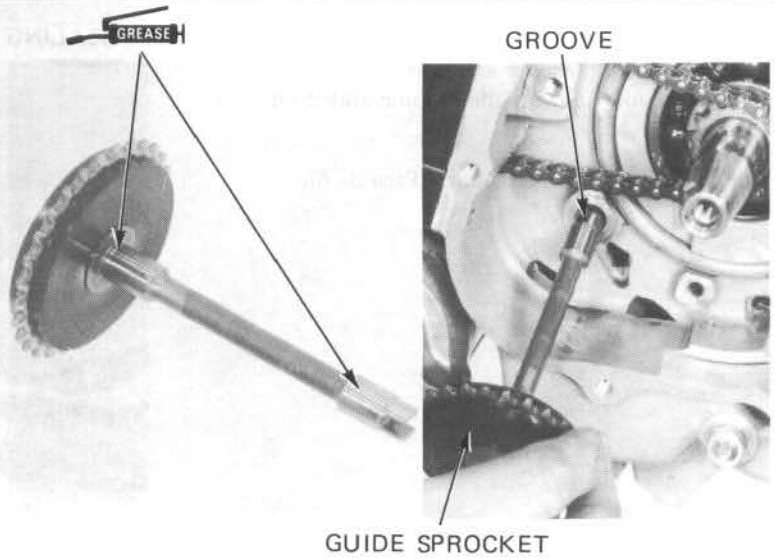

Install the guide sprocket set plate using the two bolts.

Install the left crankcase spacer (Page 9-12) and alternator (Page 9-8).

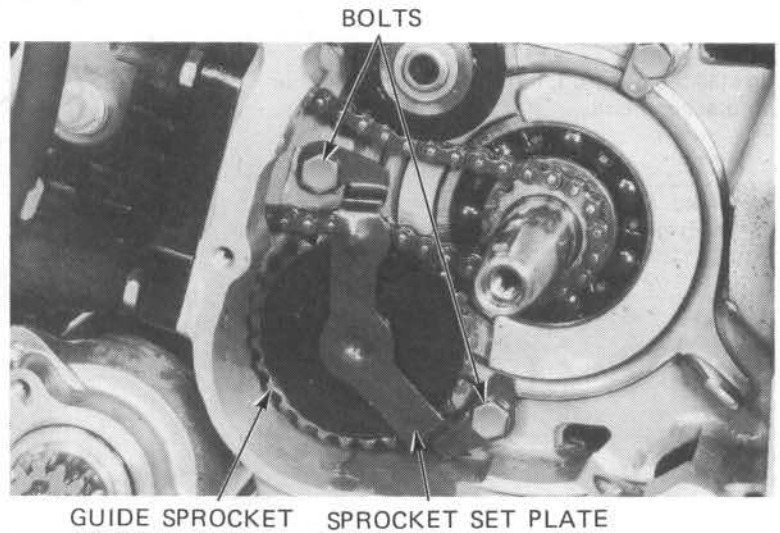

'84:
Install the push rod, tensioner spring A and B and adjusting screw.

NOTE

Face the flat surface on the push rod toward the adjusting screw.

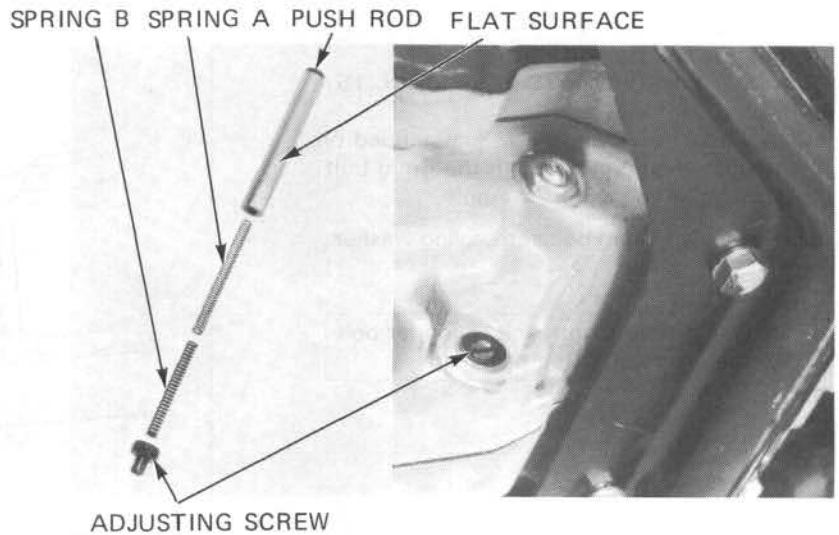

RECOIL STARTER/ALTERNATOR/CAM CHAIN TENSIONER

Install the sealing washer and bolt.
Fill the crankcase with the recommended oil
(Page 2-2).

Adjust the cam chain tensioner (Page 3-6).

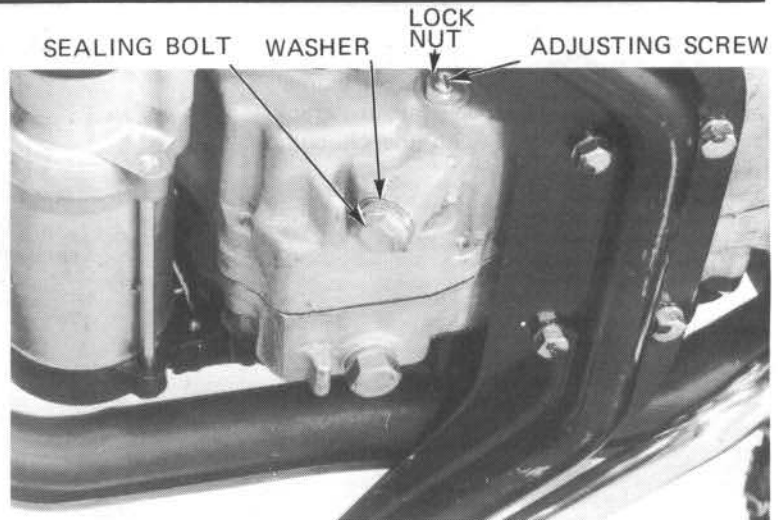

After '84:
Install the pushrod, tensioner spring, washer
and sealing bolt.

NOTE

Make sure the push rod valve is free
from dust before installation.

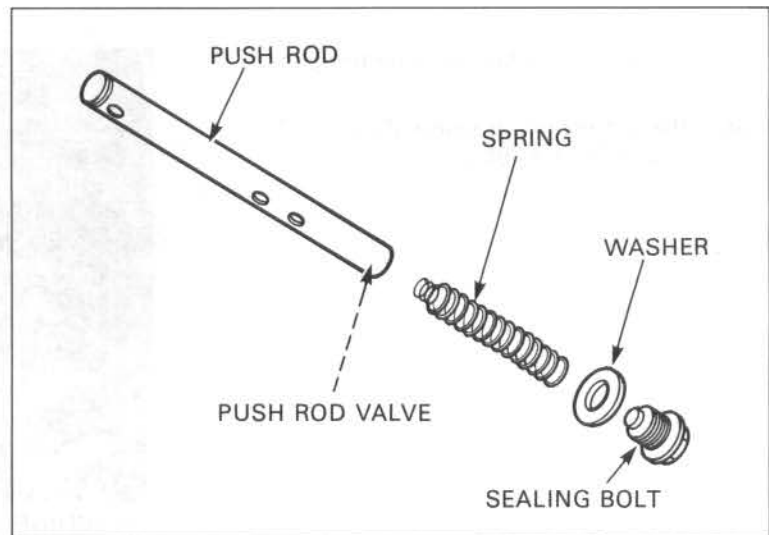

Torque the sealing bolt.
TORQUE: 20-25 N·m (2.0-2.5 kg·m, 15-18 ft·lb)

Fill the crankcase with the recommended oil.
Pour clean engine oil through the 6mm bolt
hole until oil flows out of the hole.

Install the 6 x 18 mm bolt and sealing washer.

NOTE

Use the proper length bolt. A longer bolt
may interfere with the push rod.

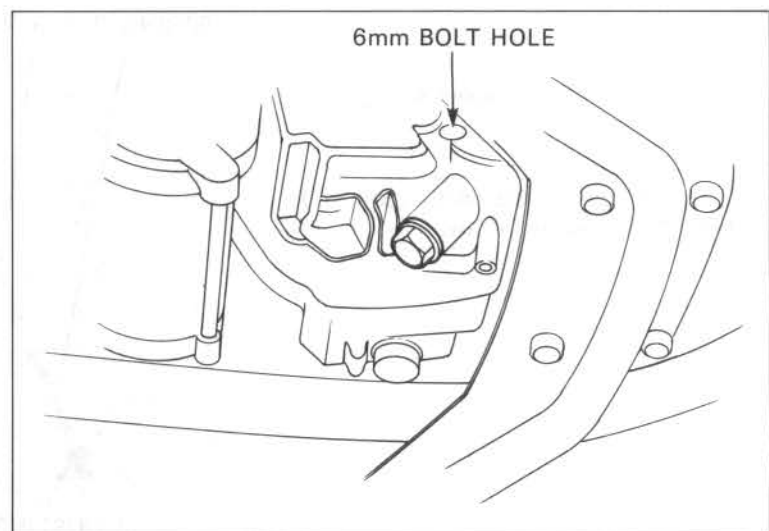

MEMO



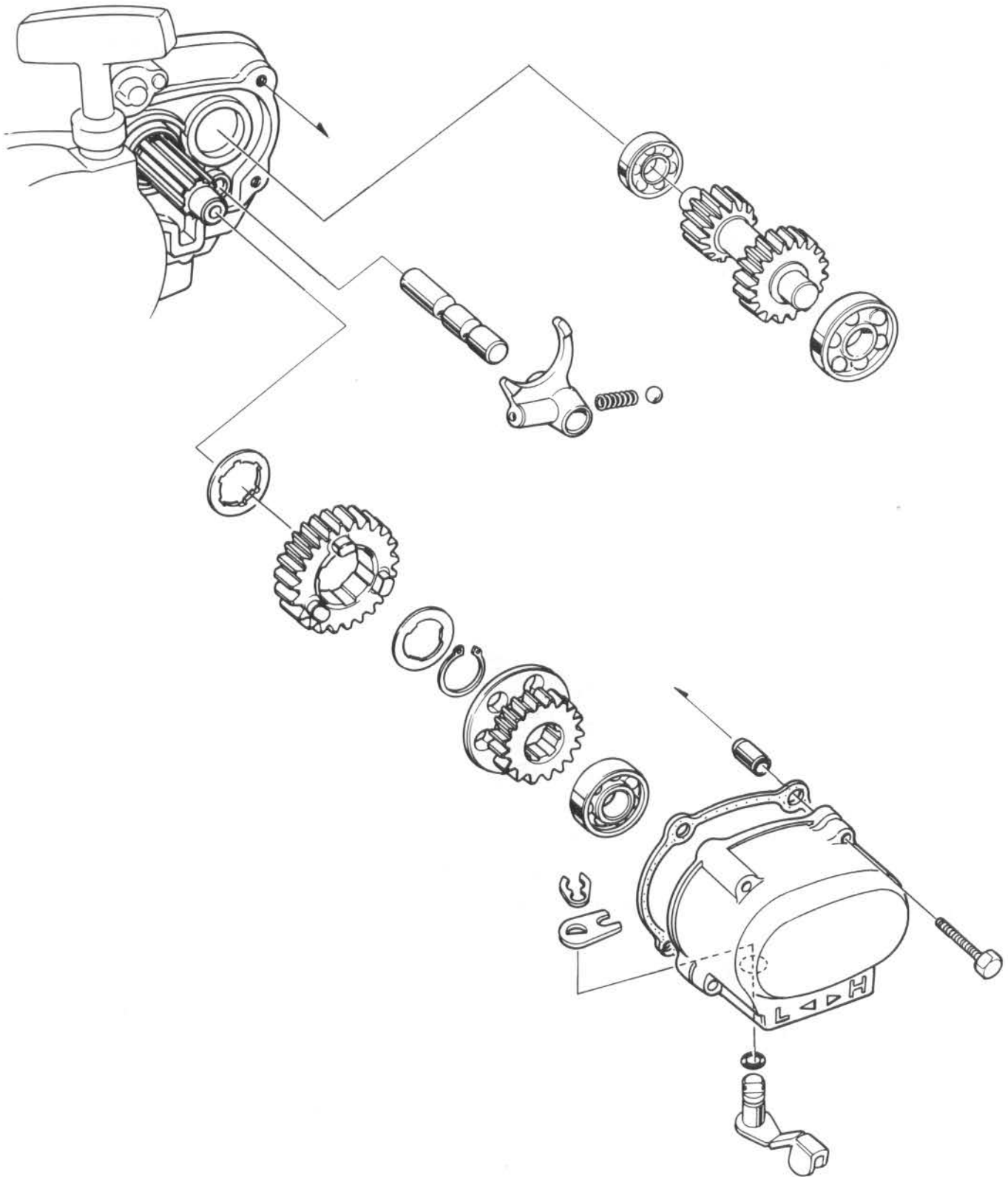

10. SUB-TRANSMISSION

SERVICE INFORMATION	10-1
TROUBLESHOOTING	10-1
SUB-TRANSMISSION REMOVAL	10-2
DRIVE SPROCKET REMOVAL	10-5
DRIVE SPROCKET INSTALLATION	10-6
SUB-TRANSMISSION INSTALLATION	10-6

SERVICE INFORMATION

GENERAL

- This section covers removal and installation of the sub-transmission and drive sprocket.

SPECIFICATIONS

ITEM		STANDARD	SERVICE LIMIT
Drive sprocket bushing	O. D.	21.960–21.993 mm (0.8646–0.8659 in)	21.90 mm (0.862 in)
	I. D.	19.992–20.008 mm (0.7871 – 0.7877 in)	19.94 mm (0.785 in)

TOOLS

Special

Bearing Remover, 15 mm	07936-KC10000 or 07936-KC10500 (U.S.A. only)
Bearing Remover, 12 mm	07936-1660100
Remover Weight	07741-0010201 (or 07936-3710200)
Remover Handle	07936-3710100

Common

Driver	07749-0010000
Attachment, 32 x 35 mm	07746-0010100
Pilot, 15 mm	07746-0040300

TROUBLESHOOTING

Gears noisy

1. Worn sub-transmission gear
2. Worn sub-transmission bearing

Hard to shift

1. Shift fork bent or damage
2. Shift fork shaft bent

SUB-TRANSMISSION REMOVAL

Remove the rear fender assembly.
Remove the sub-transmission cover.

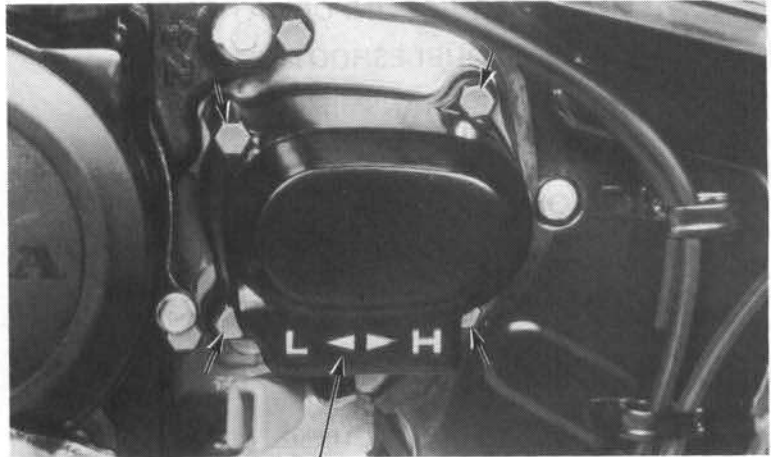

COVER

Remove the dowel pins and gasket.
Remove the idler gear.

Pull up the shift fork with the shift fork shaft,
and remove the low gear.

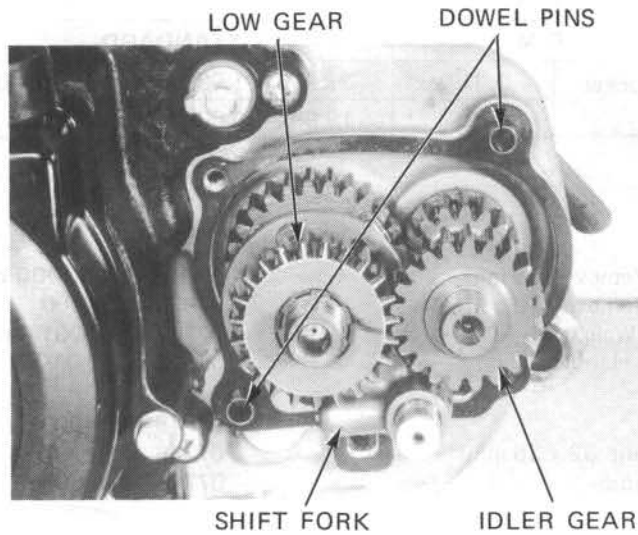

Remove the snap ring, then remove the high
speed gear.

Check the gears for wear or damage.

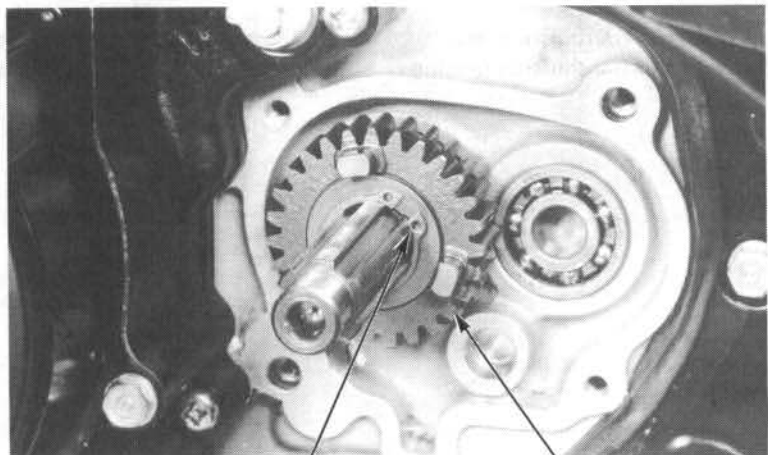

Remove the thrust washer.

THRUST WASHER



Remove the clip securing the shift lever, shift plate and shift lever from the sub-transmission cover.

SHIFT PLATE

CLIP

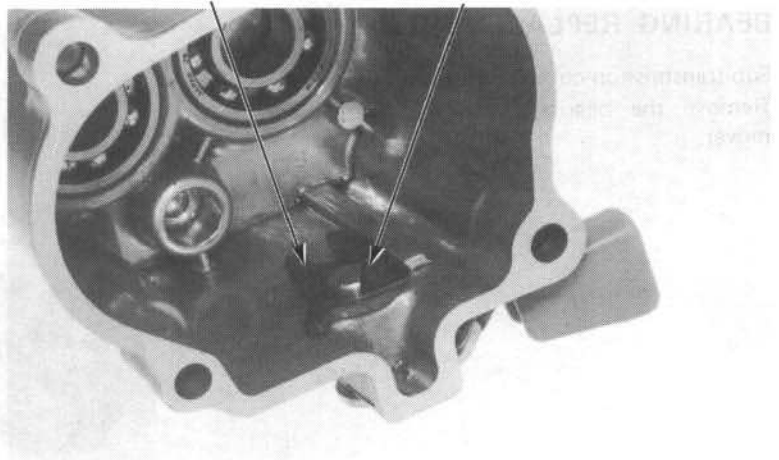

INSPECTION

Check the shift fork for damage. Inspect the spring for weakness or breakage.

Check the low and high gears for excessive wear.

CHECK FOR

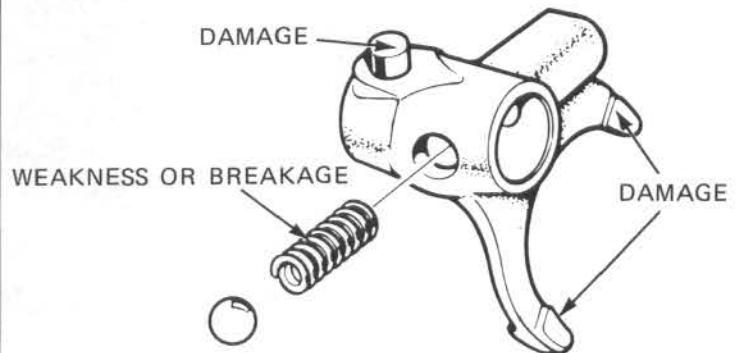

SUB-TRANSMISSION

Spin the bearing by hand and check for play. The bearing must be replaced if it is noisy or has excessive play.

IDLER GEAR BEARINGS

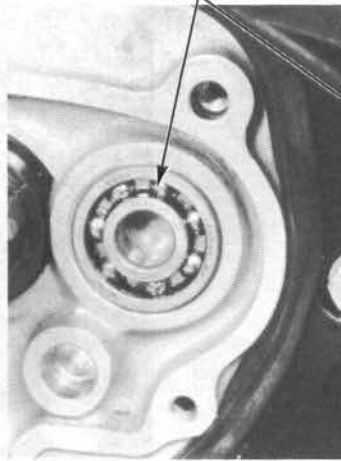

COUNTERSHAFT BEARING

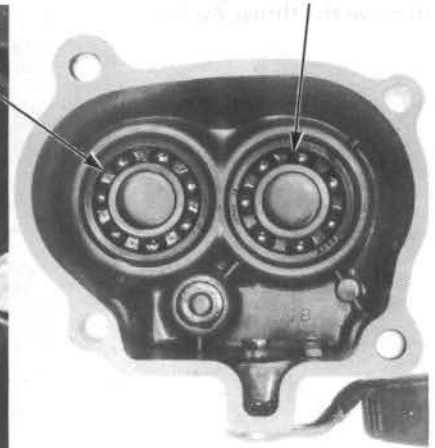

BEARING REPLACEMENT

Sub-transmission cover bearings:
Remove the bearings with the bearing remover.

BEARING REMOVER, 15 mm 07936-KC1000
OR 07936-KC10500 (U.S.A. ONLY)

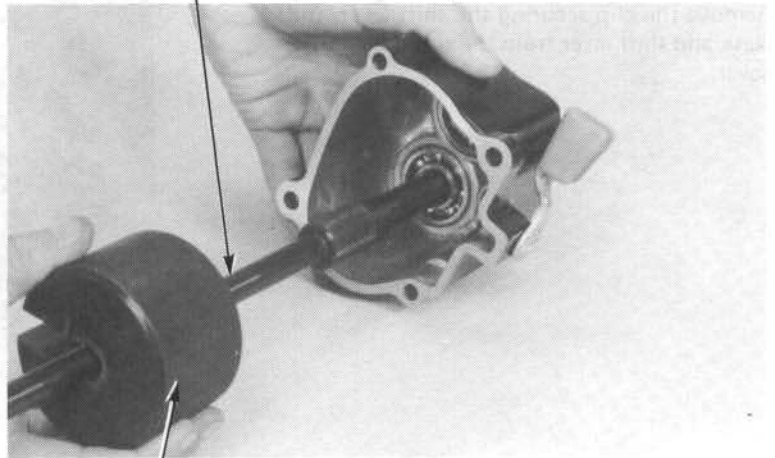

REMOVER WEIGHT 07936-3710200
OR 07741-0010201

Drive the bearing into the sub-transmission cover.

DRIVER 07749-0010000

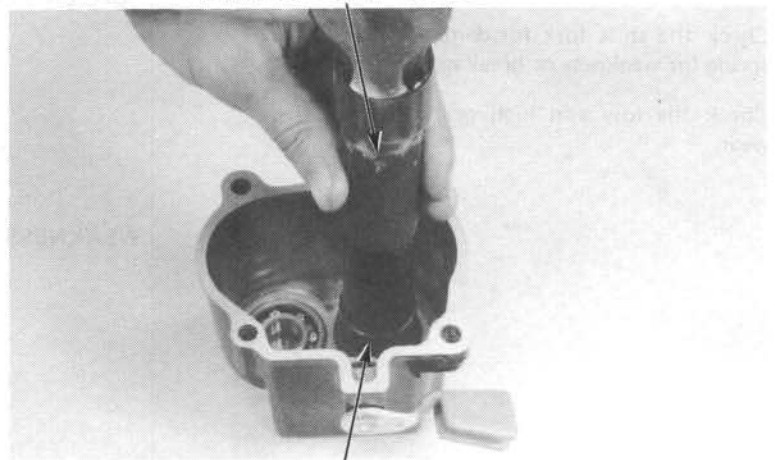

ATTACHMENT, 32 x 35 mm 07746-0010100
PILOT, 15 mm 07746-0040300

Left crankcase cover bearing:
Remove the left crankcase cover spacer (Page 9-10).

Remove the bearing with the bearing remover.

BEARING REMOVER, 12 mm 07936-1660100

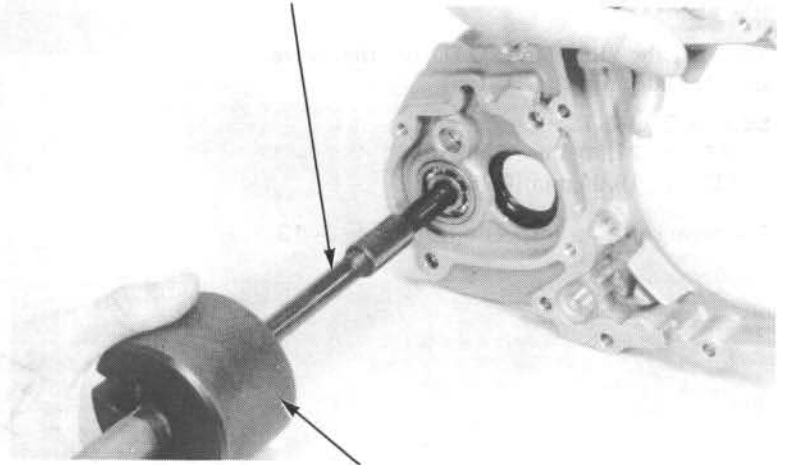

REMOVER WEIGHT
07936-3710200 or 07741-0010201

Drive the bearing into the spacer.

DRIVER 07749-0010000



ATTACHMENT, 32 x 35 mm 07746-0010100
PILOT, 12 mm 07746-0040200

DRIVE SPROCKET REMOVAL

Remove the sub-transmission (Page 10-2).
Remove the left crankcase cover spacer (Page 9-10).

Remove the drive chain (Page 13-4).
Remove the drive sprocket and bushings.

DRIVE SPROCKET

DRIVE CHAIN

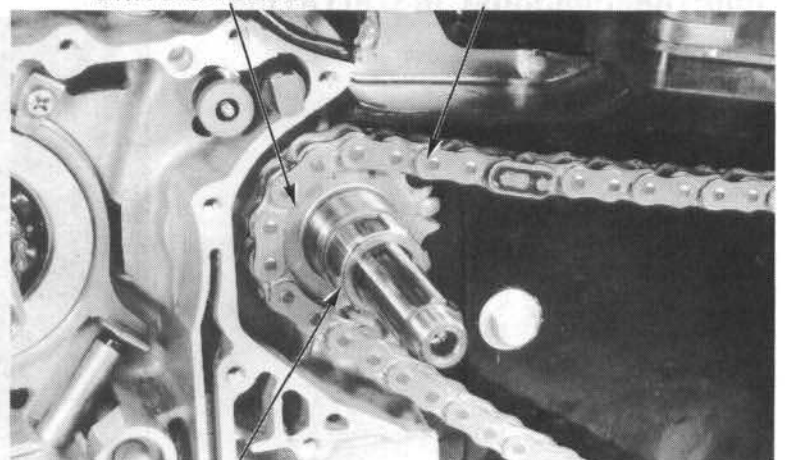

BUSHING

SUB-TRANSMISSION

INSPECTION

Measure the I.D. and O.D. of the drive sprocket bushings.

SERVICE LIMITS:

O.D. : 21.90 mm (0.862 in)

I.D. : 19.94 mm (0.785 in)

For drive sprocket inspection, see page 3-13.

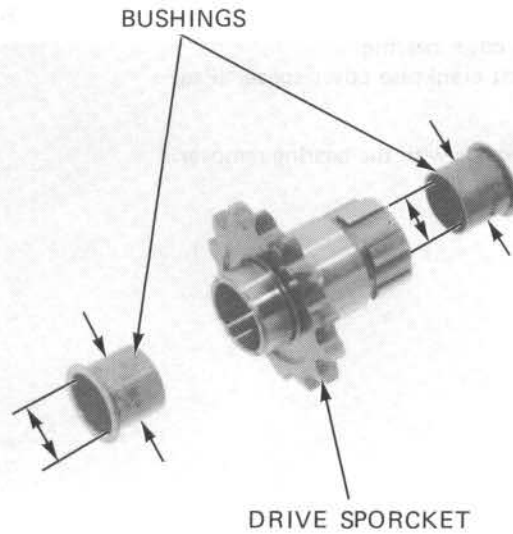

DRIVE SPROCKET INSTALLATION

Install the drive sprocket and bushings over the countershaft.

Install the drive chain (Page 13-10).

Install the following components:

- left crankcase cover spacer (Page 9-12).
- starter gears (Page 9-13).
- alternator (Page 9-8).
- recoil starter (Page 9-6).

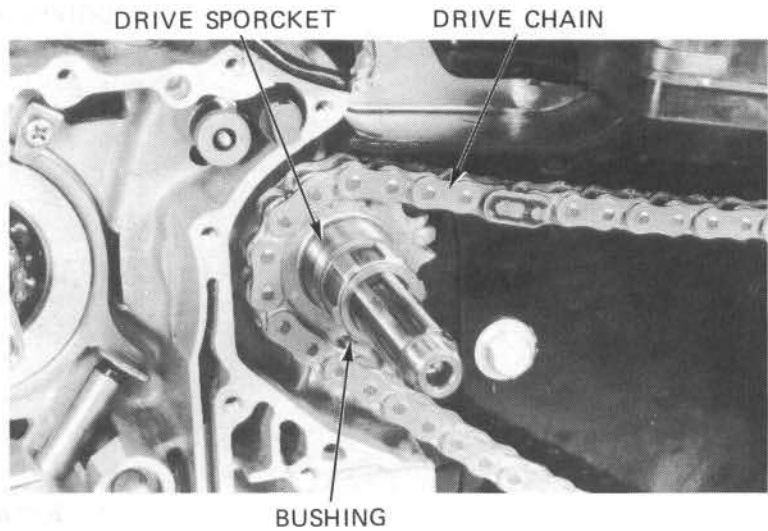

SUB-TRANSMISSION INSTALLATION

Install the thrust washer over the drive sprocket.

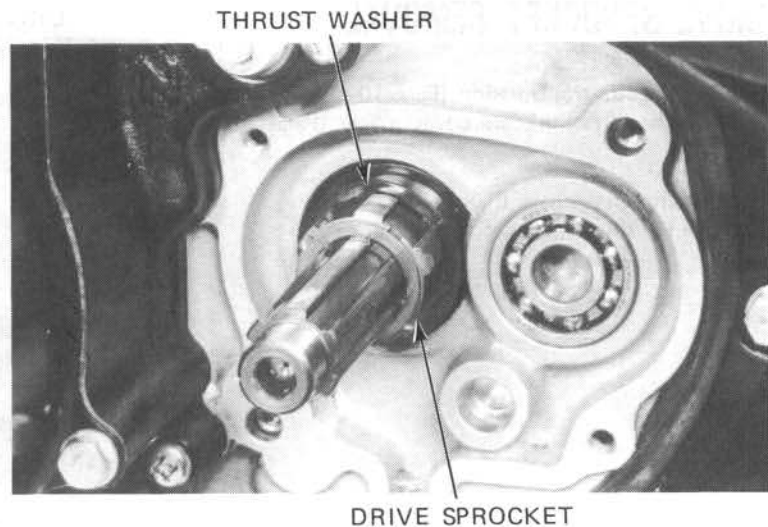

Install the high speed gear over the mainshaft and secure it with the snap ring.

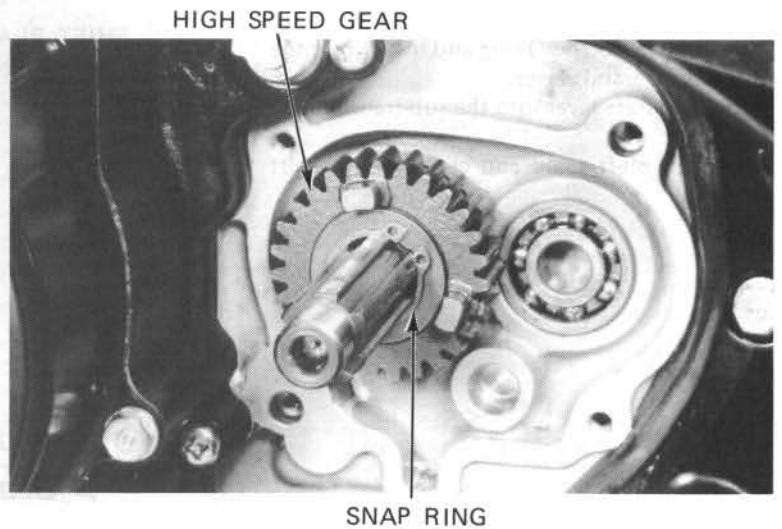

Install the spring and steel ball into the hole in the shift fork.
Push the steel ball in and insert the shift fork shaft into the fork so the long section faces the left crankcase cover spacer when installed.

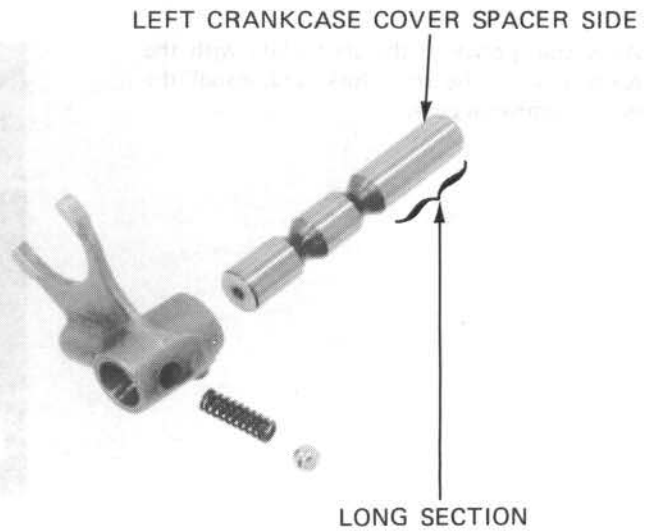
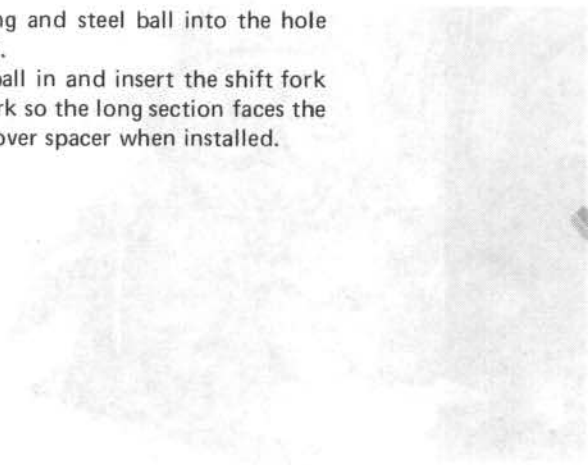

Install the low gear, shift fork and idler gears.
Install the dowel pins and new gasket.

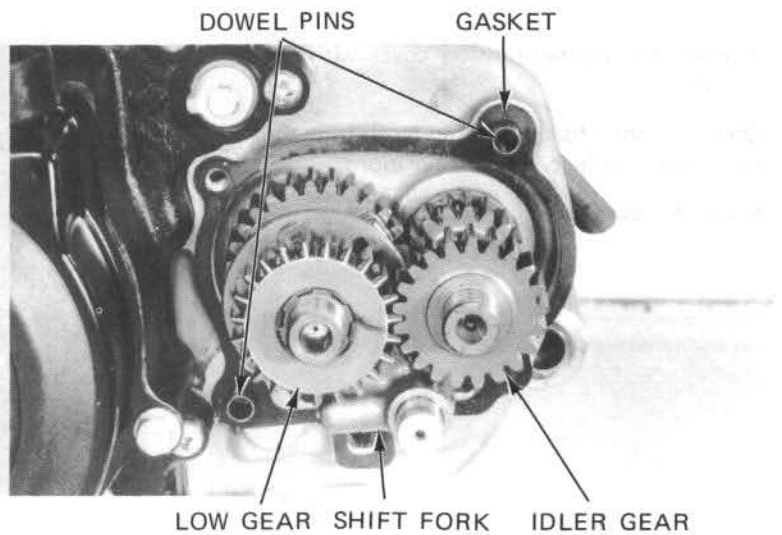

SUB-TRANSMISSION

Apply grease to the O-ring and install it in the groove of the shift lever.
Insert the shift lever into the sub-transmission cover.
Install the shift plate and clip over the shift lever.

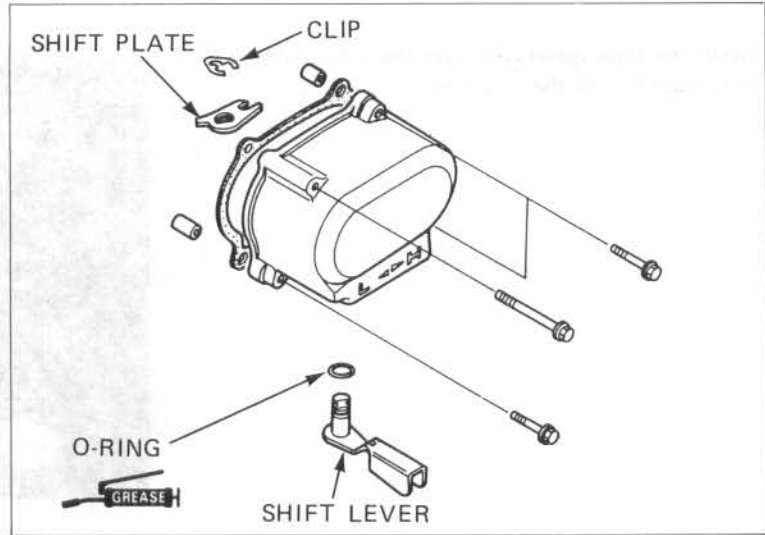

Align the groove in the shift plate with the guide pin on the shift fork and install the sub-transmission cover.

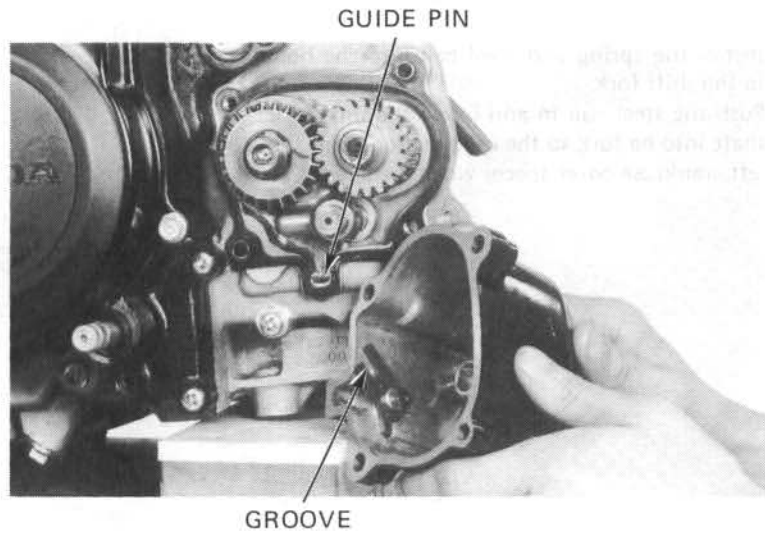

Tighten the sub-transmission cover with the four bolts.

Check the shift fork operation by shifting the shift lever into high and low positions.

Install the rear fender.

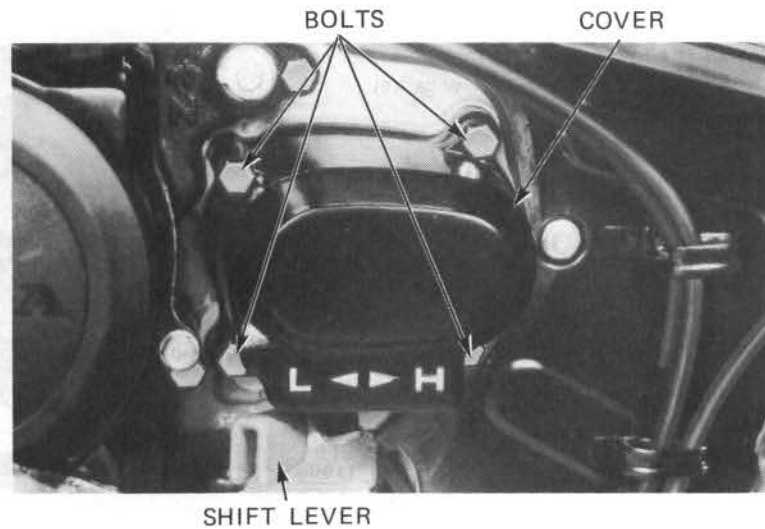

MEMO



TRANSMISSION/CRANKSHAFT

8–12 N·m (0.8–1.2 kg·m,
6–9 ft·lb)

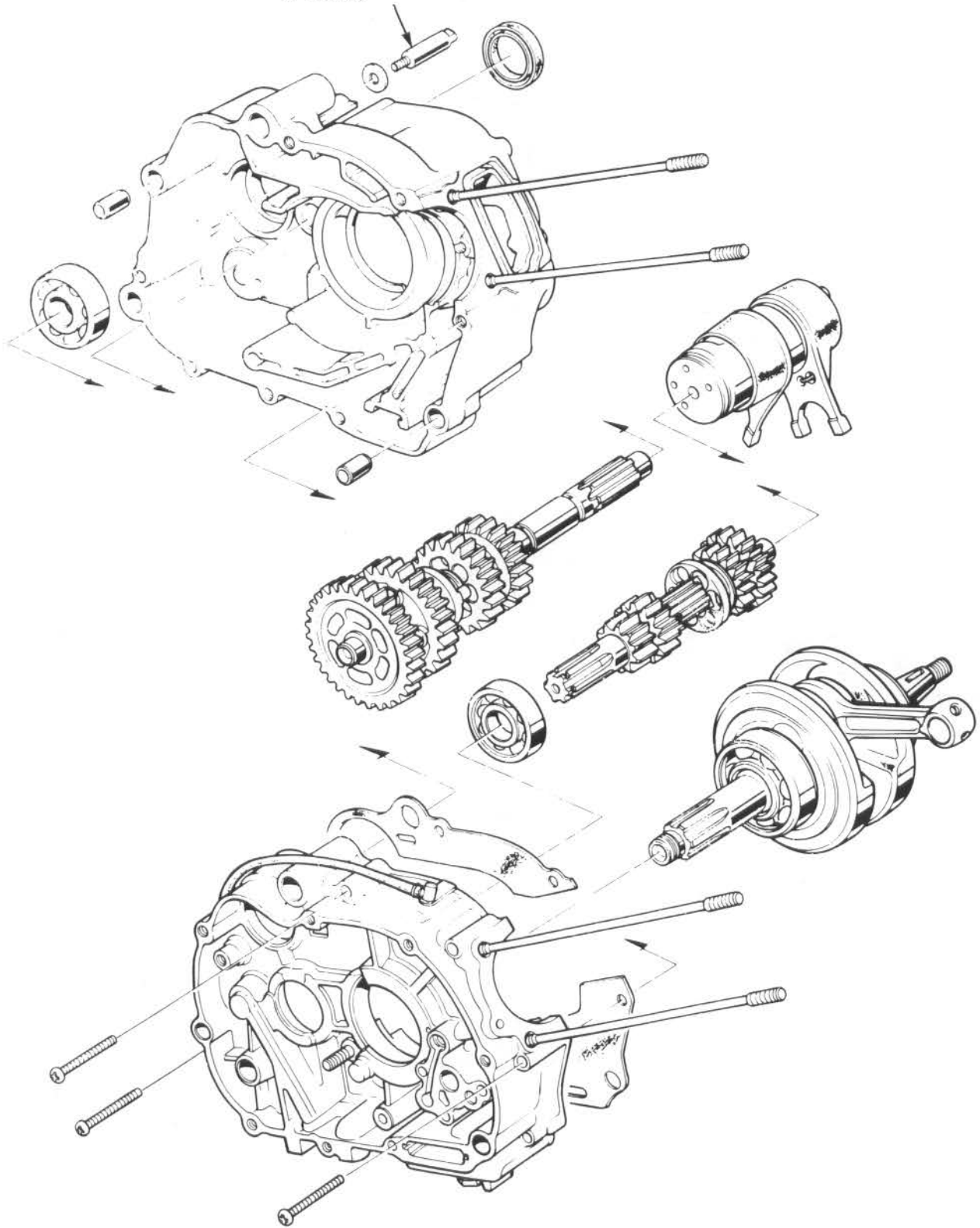

11. TRANSMISSION/ CRANKSHAFT

SERVICE INFORMATION	11-1
TROUBLESHOOTING	11-2
CRANKCASE SEPARATION	11-3
CRANKSHAFT REMOVAL	11-4
TRANSMISSION DISASSEMBLY	11-6
TRANSMISSION ASSEMBLY	11-9
CRANKCASE ASSEMBLY	11-10

SERVICE INFORMATION

GENERAL

- Use care not to damage the oil pressure pad on the crankshaft right end.
- The crankcase must be separated to service the crankshaft and transmission.
- Remove the engine before separating the crankcase, and then remove the following parts:
 - Cylinder head Section 6
 - Cylinder and piston Section 7
 - Clutch and gearshift linkage Section 8
 - Alternator and cam chain tensioner Section 9
 - Sub-transmission Section 10

SPECIFICATIONS

ITEM		STANDARD	SERVICE LIMIT	
Crankshaft	Runout (right/left)		0.10 mm (0.004 in)	
	Connecting rod big end side clearance	0.05–0.30 mm (0.002–0.012 in)	0.8 mm (0.03 in)	
	Connecting rod small end radial clearance	0–0.008 mm (0–0.0003 in)	0.05 mm (0.002 in)	
	Connecting rod small end	15.016–15.034 mm (0.5912–0.5919 in)	15.05 mm (0.593 in)	
Transmission	Shift fork I.D.	42.000–42.025 mm (1.6535–1.6545 in)	42.1 mm (1.66 in)	
	Gearshift drum O.D.	41.950–41.975 mm (1.6516–1.6526 in)	41.8 mm (1.65 in)	
	Shift fork-to-shift drum clearance	0.025–0.075 mm (0.0010–0.0030 in)	0.10 mm (0.004 in)	
	Drum groove width	6.1–6.2 mm (0.240–0.244 in)	6.4 mm (0.25 in)	
	Shift fork end thickness	5.96–0.04 mm (0.234–0.238 in)	5.70 mm (0.224 in)	
	Transmission gear I.D.	C1	14.000–14.027 mm (0.5512–0.5522 in)	14.10 mm (0.555 in)
		M2	18.000–18.018 mm (0.7087–0.7094 in)	18.08 mm (0.712 in)
M4		20.000–20.021 mm (0.7874–0.7882 in)	20.10 mm (0.791 in)	
C3		14.000–14.027 mm (0.5512–0.5522 in)	14.10 mm (0.555 in)	

TRANSMISSION/CRANKSHAFT

ITEM			STANDARD	SERVICE LIMIT
Transmission	Countershaft and mainshaft O.D.	C1	13.966–13.984 mm (0.5498–0.5506 in)	13.93 mm (0.548 in)
		M2	17.966–17.984 mm (0.7073–0.7080 in)	17.93 mm (0.706 in)
		C3	19.966–19.984 mm (0.7861–0.7868 in)	19.93 mm (0.785 in)
		M4	13.966–13.984 mm (0.5498–0.5506 in)	13.93 mm (0.548 in)

TORQUE VALUE

Neutral indicator shaft

8–12 N·m (0.8–1.2 kg-m, 6–9 ft-lb)

TOOLS

Common

Driver

Attachment, 42 x 47 mm

Pilot, 20 mm

07749–0010000

07746–0010300

07746–0040500

TROUBLESHOOTING

Hard to shift

1. Shift fork bent
2. Shift fork shaft bent

Transmission jumps out of gear

1. Gear dogs worn
2. Shift fork bent or damaged

Crankshaft noisy

1. Worn connecting rod big end bearing
2. Bent connecting rod
3. Worn crankshaft main journal bearing

Gears noisy

- Worn transmission gear

CRANKCASE SEPARATION

Remove the neutral indicator shaft.

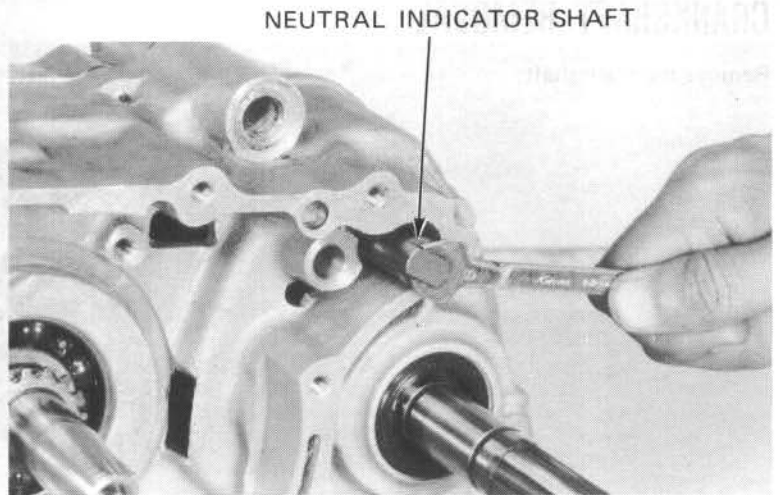

Remove the crankcase breather tube.
Remove the nine 6 mm screws.

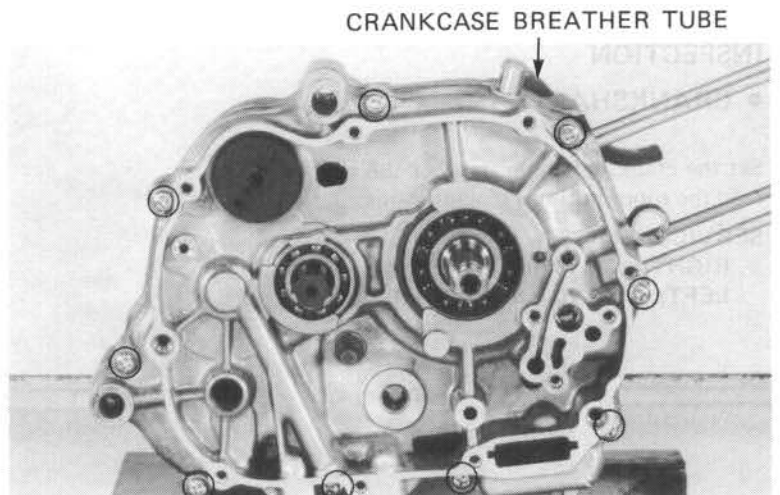

Place the engine with the left crankcase side down and separate the right crankcase from the left crankcase while tapping them at several locations with a soft hammer.

CAUTION

Do not pry between the left and right crankcases.

Remove the dowel pins and gasket.

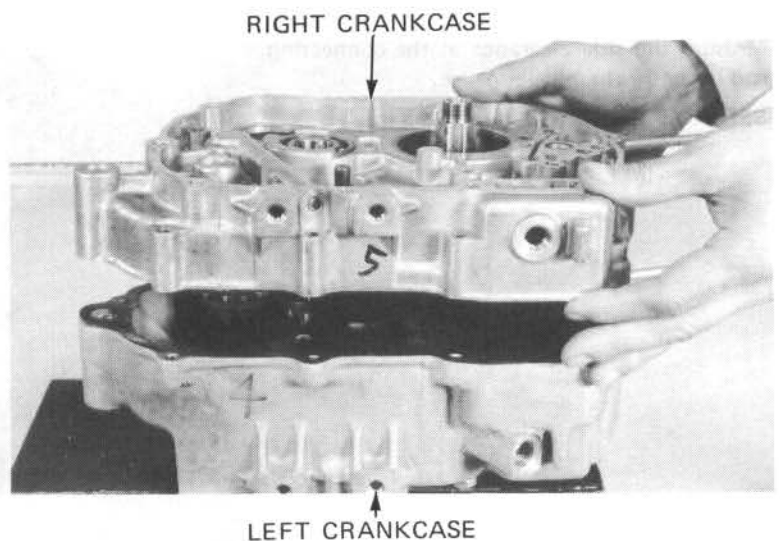

CRANKSHAFT REMOVAL

Remove the crankshaft.

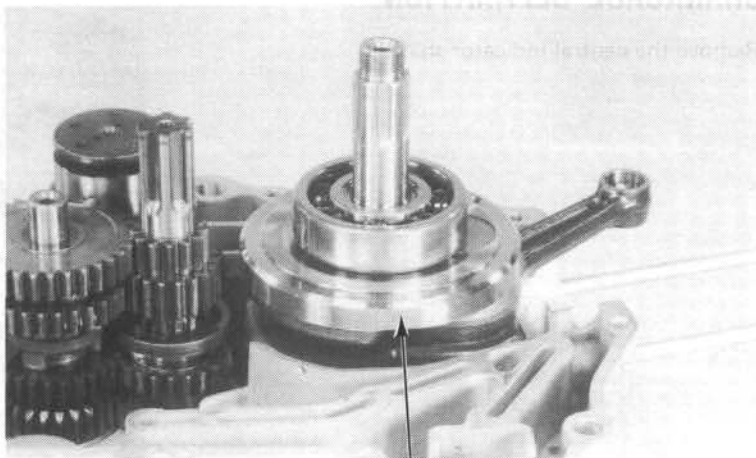

CRANKSHAFT

INSPECTION

● CRANKSHAFT

Set the crankshaft on a stand or V-blocks and read the runout using a dial indicator.

SERVICE LIMITS:

RIGHT: 0.10 mm (0.004 in)

LEFT: 0.10 mm (0.004 in)

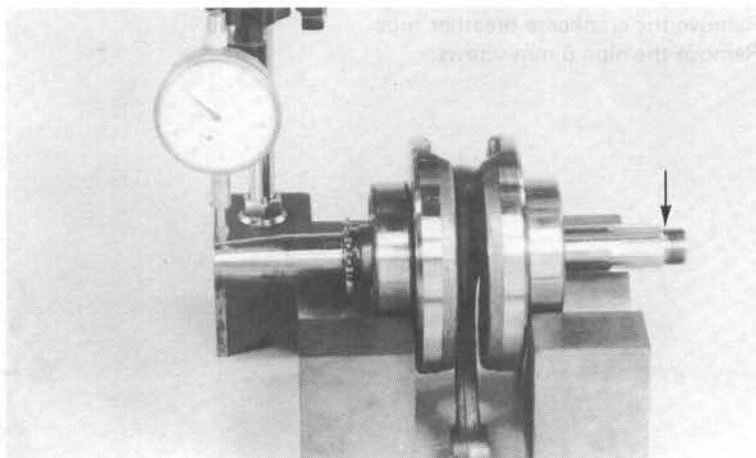

Measure the side clearance at the connecting rod big end with a feeler gauge.

SERVICE LIMIT: 0.8 mm (0.03 in)

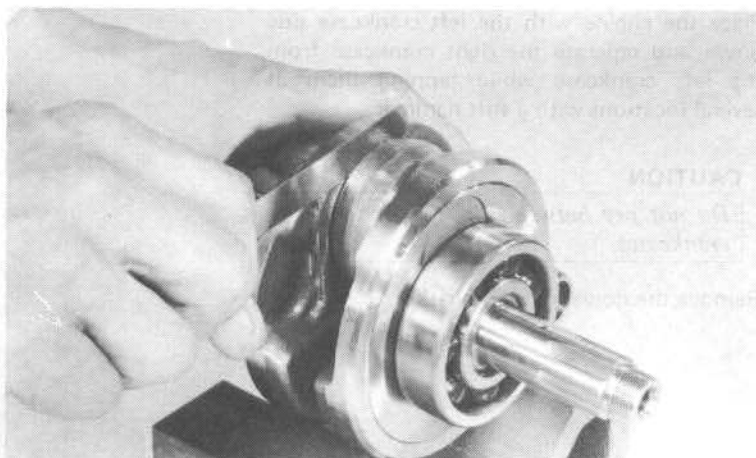

Measure the radial clearance at the connecting rod big end, at two points in the direction indicated by the arrows.

SERVICE LIMIT: 0.05 mm (0.002 in)

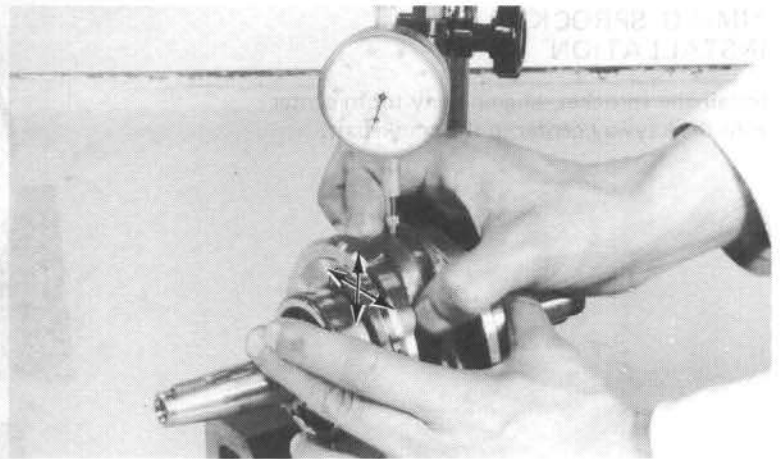

Measure the connecting rod small end I.D.

SERVICE LIMIT: 15.05 mm (0.593 in)

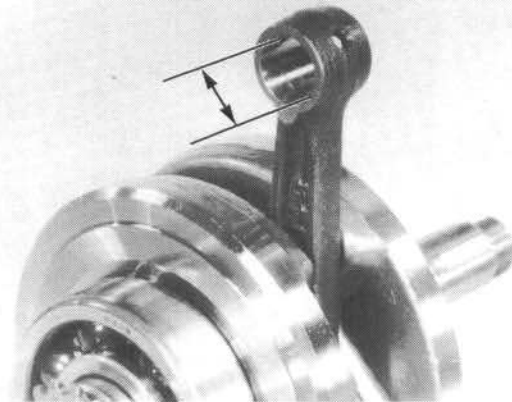

● **CRANKSHAFT BEARING**

Spin the crankshaft bearing by hand and check for play.

The bearing must be replaced if it is noisy or has excessive play.

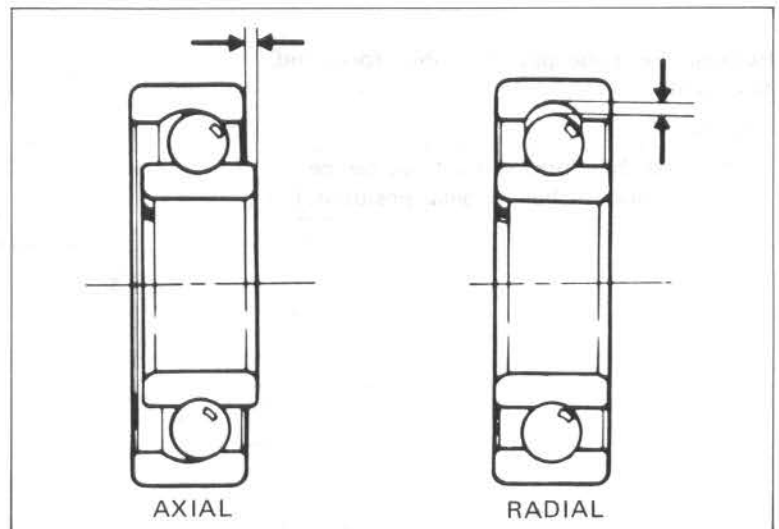

TIMING SPROCKET INSTALLATION

Install the sprocket, aligning any tooth center with the keyway center in the crankshaft.

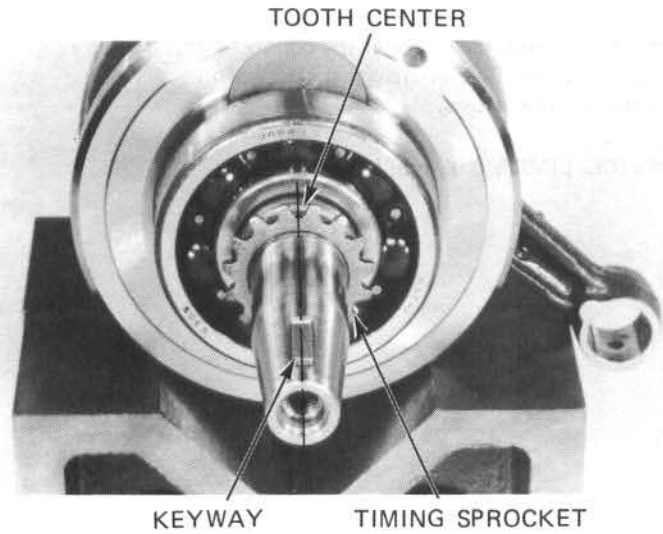

TRANSMISSION DISASSEMBLY

Remove the transmission and gearshift drum as an assembly.

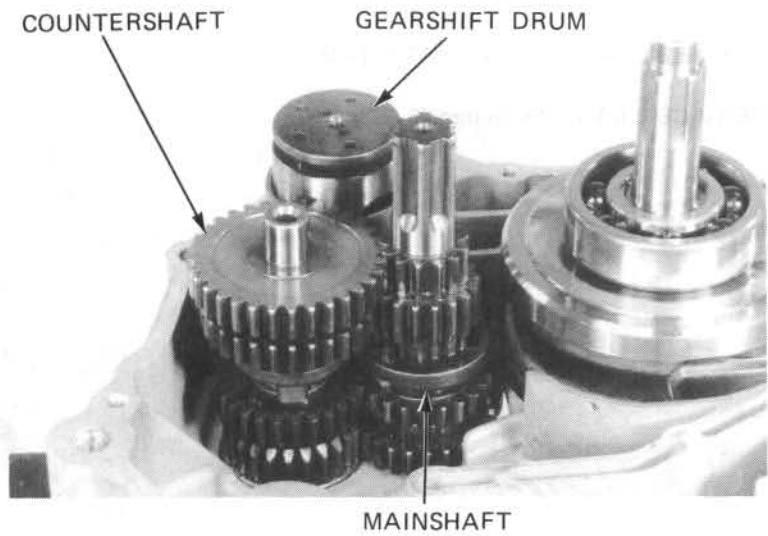

Remove the guide pin clips, shift forks and guide pins.

NOTE

Mark the shift forks so that they can be placed back in their original positions.

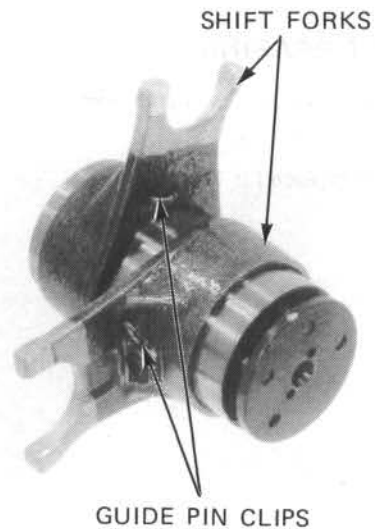

Check the shift forks for wear, bending or damage.

Measure the I. D. of the shift forks.

SERVICE LIMIT: 42.1 mm (1.66 in)

Measure the shift fork end thickness.

SERVICE LIMIT: 5.70 mm (0.224 in)

Inspect the guide pins for wear or damage.

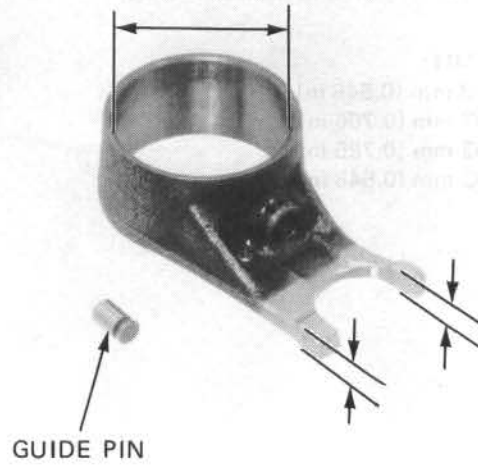

Measure the gearshift drum O. D.

SERVICE LIMIT: 41.8 mm (1.65 in)

Calculate the shift fork to shift drum clearance.

SERVICE LIMIT: 0.10 mm (0.004 in)

Measure the gearshift drum groove width.

SERVICE LIMIT: 6.4 mm (0.25 in)

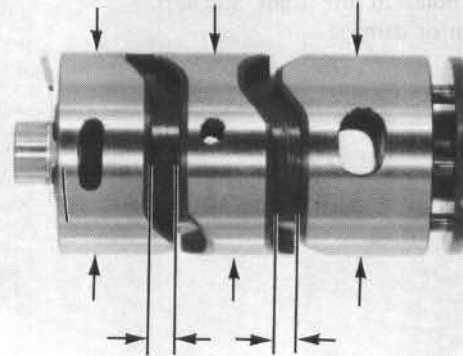

Remove the transmission gears.

Measure each gear's I. D.

SERVICE LIMITS:

C 1st: 14.10 mm (0.555 in)

M 2nd: 18.08 mm (0.712 in)

C 3rd: 20.10 mm (0.791 in)

M 4th: 14.10 mm (0.555 in)

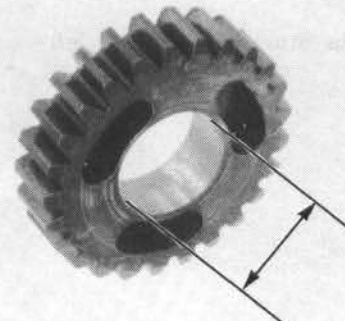

TRANSMISSION/CRANKSHAFT

Measure the countershaft and mainshaft O. D.

SERVICE LIMIT:

- C1: 13.93 mm (0.548 in)
- M2: 17.93 mm (0.706 in)
- C3: 19.93 mm (0.785 in)
- M4: 13.93 mm (0.548 in)

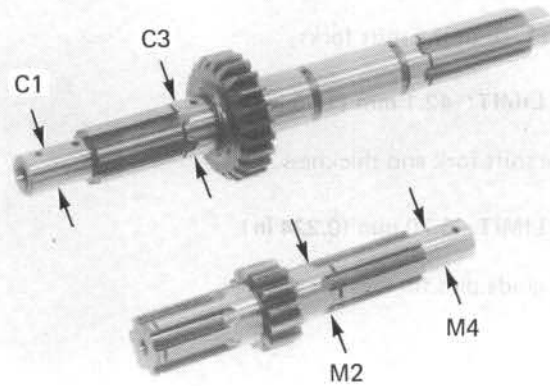

Check the bearings for excessive play or damage.
Check the shaft holes in the right and left crankcases for wear or damage.

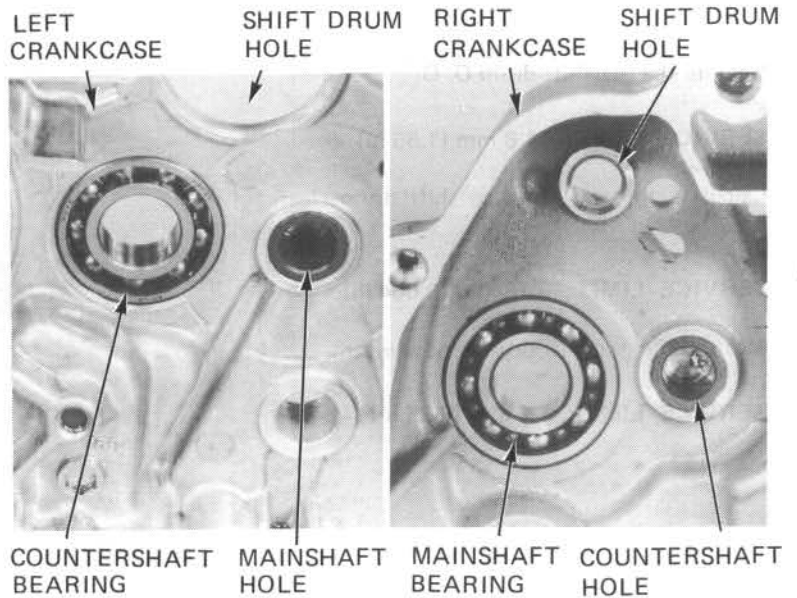

BEARING REPLACEMENT

Remove the bearings from the right and left crankcases.
Drive new bearings into the right and left crankcases.

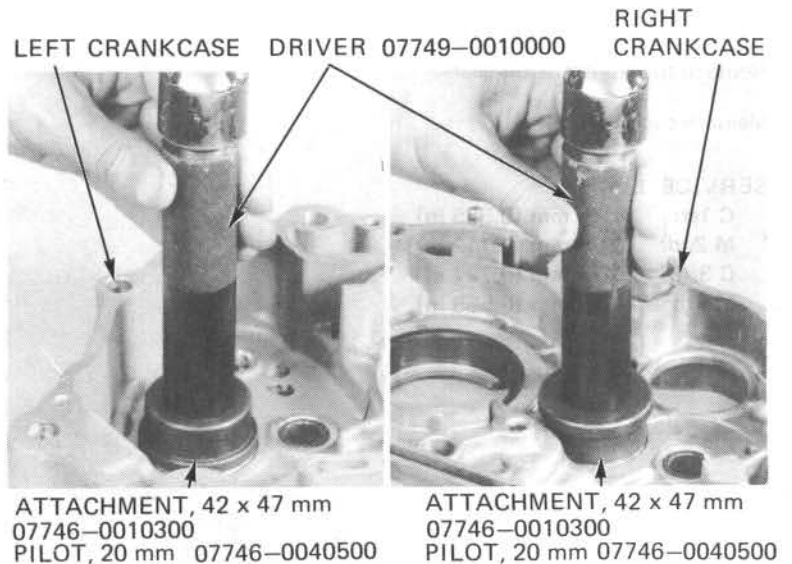

TRANSMISSION ASSEMBLY

Coat all parts with oil.

Assemble the transmission shafts and gears noting the locations of the thrust washers and snap rings.

NOTE

Make sure the snap rings are seated properly.

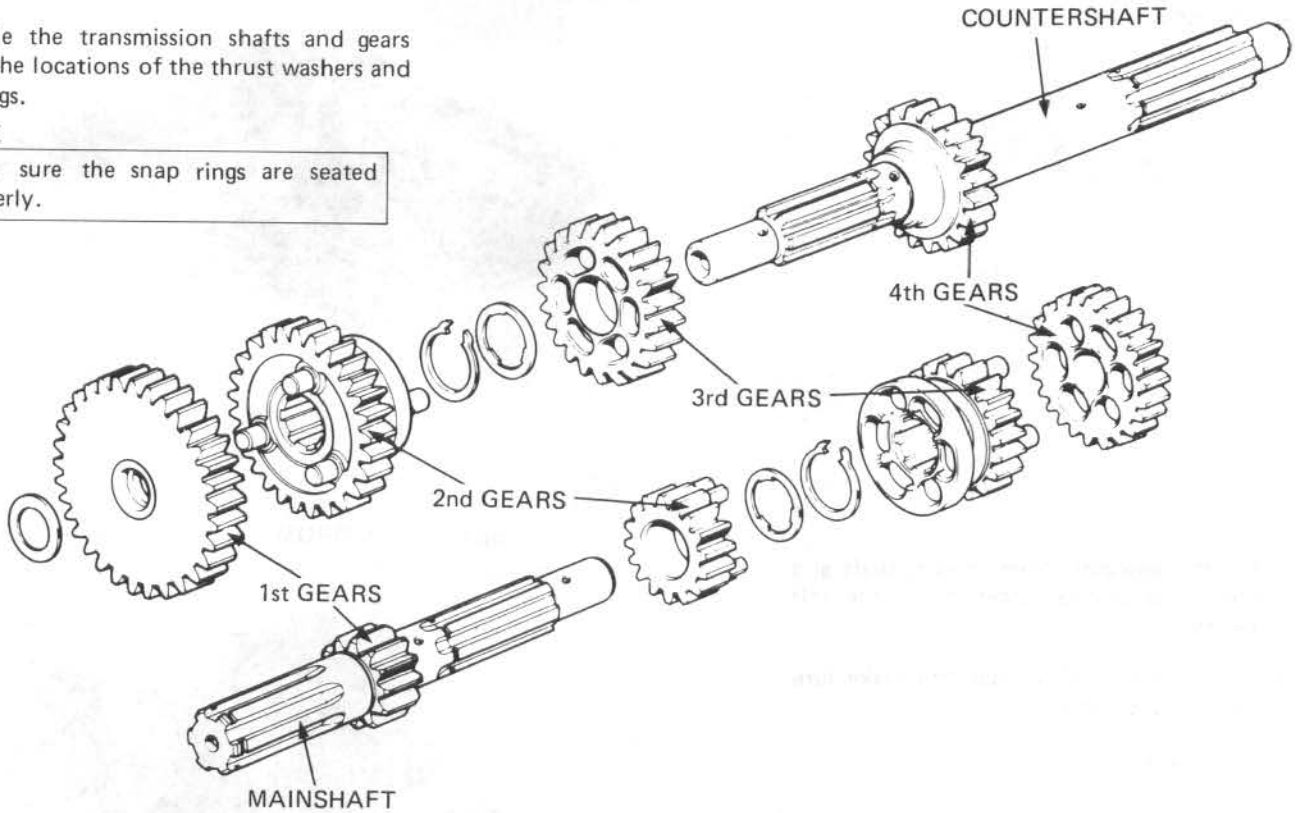

Install the shift forks in the original positions from which they were removed.

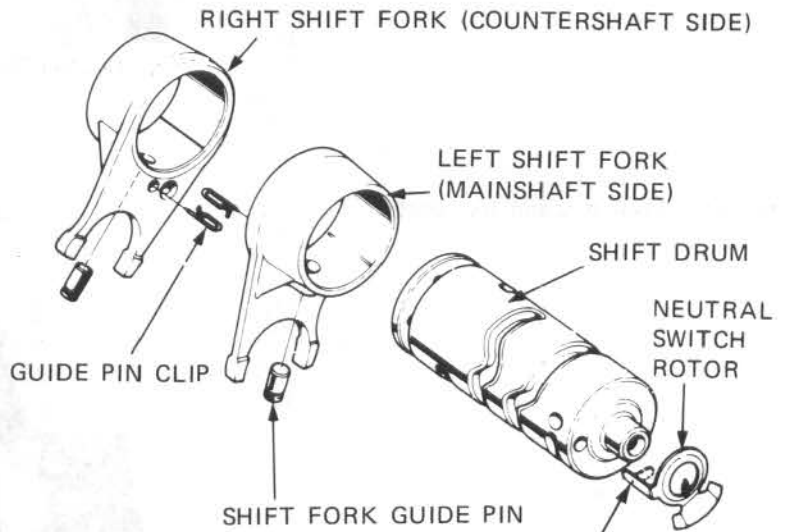

NOTE

Bend the tab of the rotor into the drum.

CRANKCASE ASSEMBLY

Assemble the gearshift drum, countershaft and mainshaft.

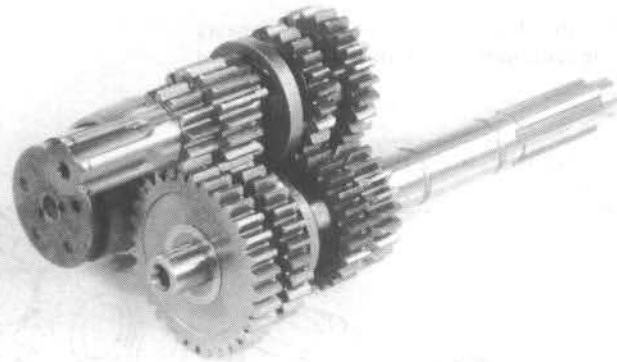

Install the gearshift drum, countershaft and mainshaft assemblies together in the left crankcase.

Rotate the mainshaft by hand to make sure the gears rotate freely.

Install the crankshaft.

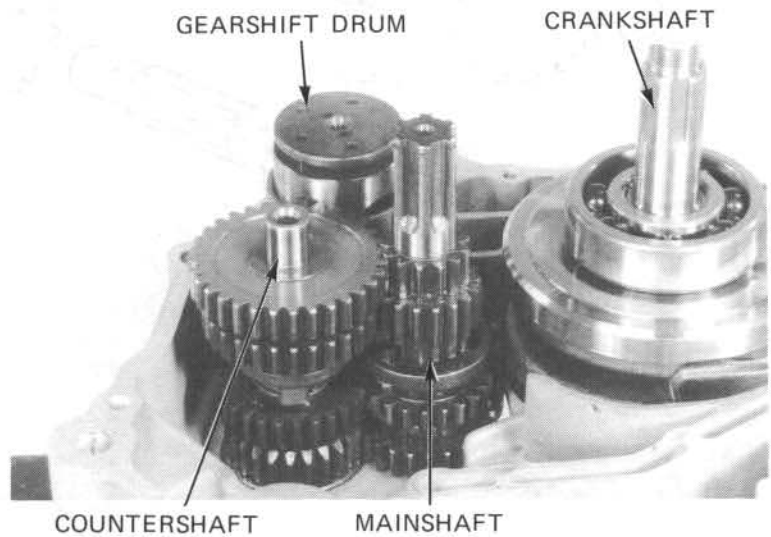

Install the dowel pins and new gasket.

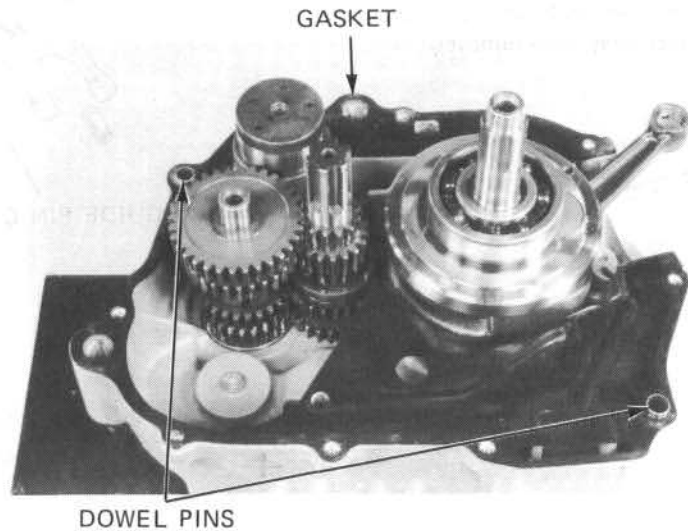

Assemble the right and left crankcase halves.

NOTE

Make sure that the gasket stays in place during this operation.

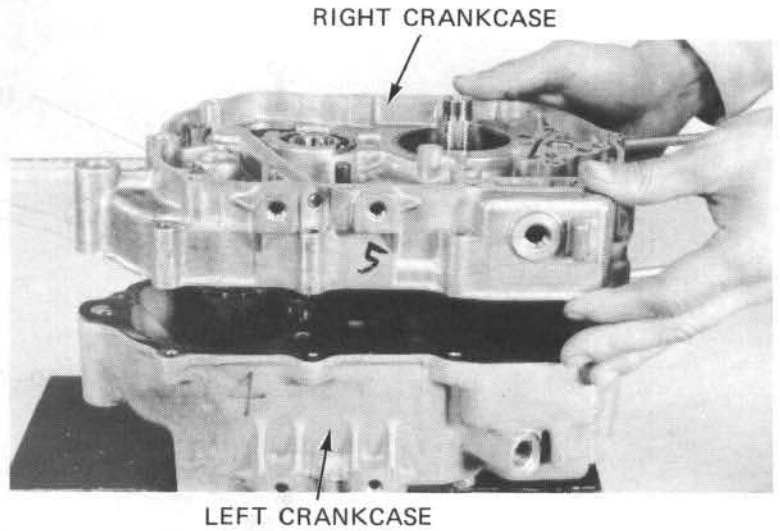

Tighten the 6 mm screws in a crisscross patterns in 2-3 steps.

Install the crankcase breather tube.

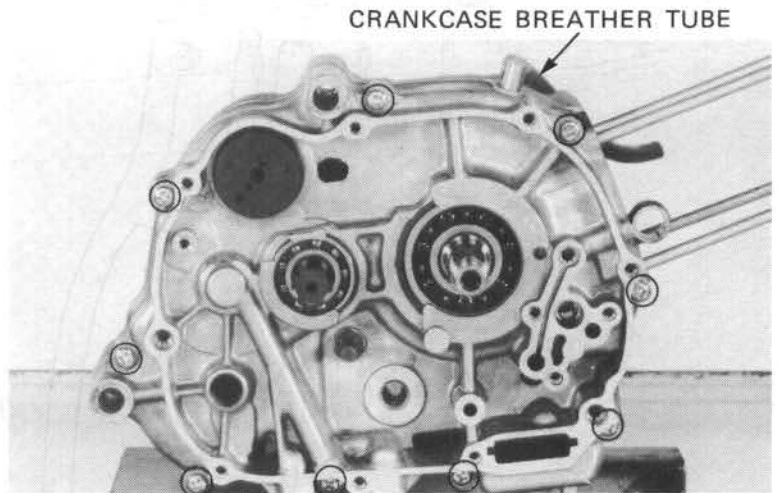

Tighten the neutral indicator shaft.

TORQUE: 8–12 N·m (0.8–1.2 kg·m, 6–9 ft·lb)

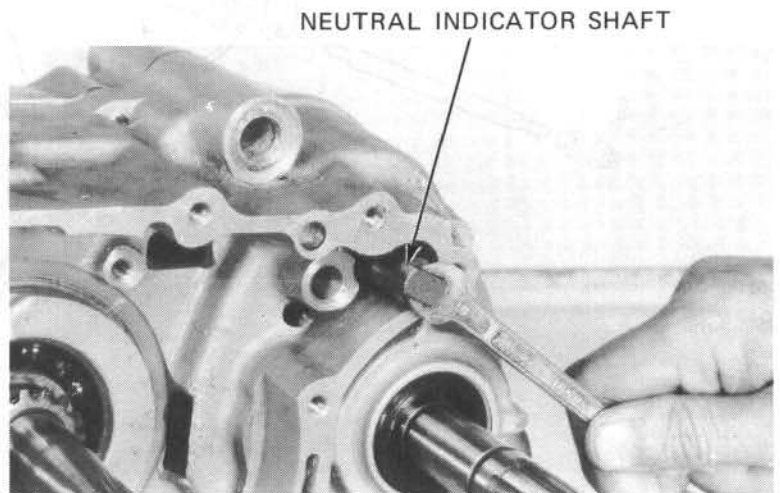

FRONT WHEEL/BRAKE/STEERING

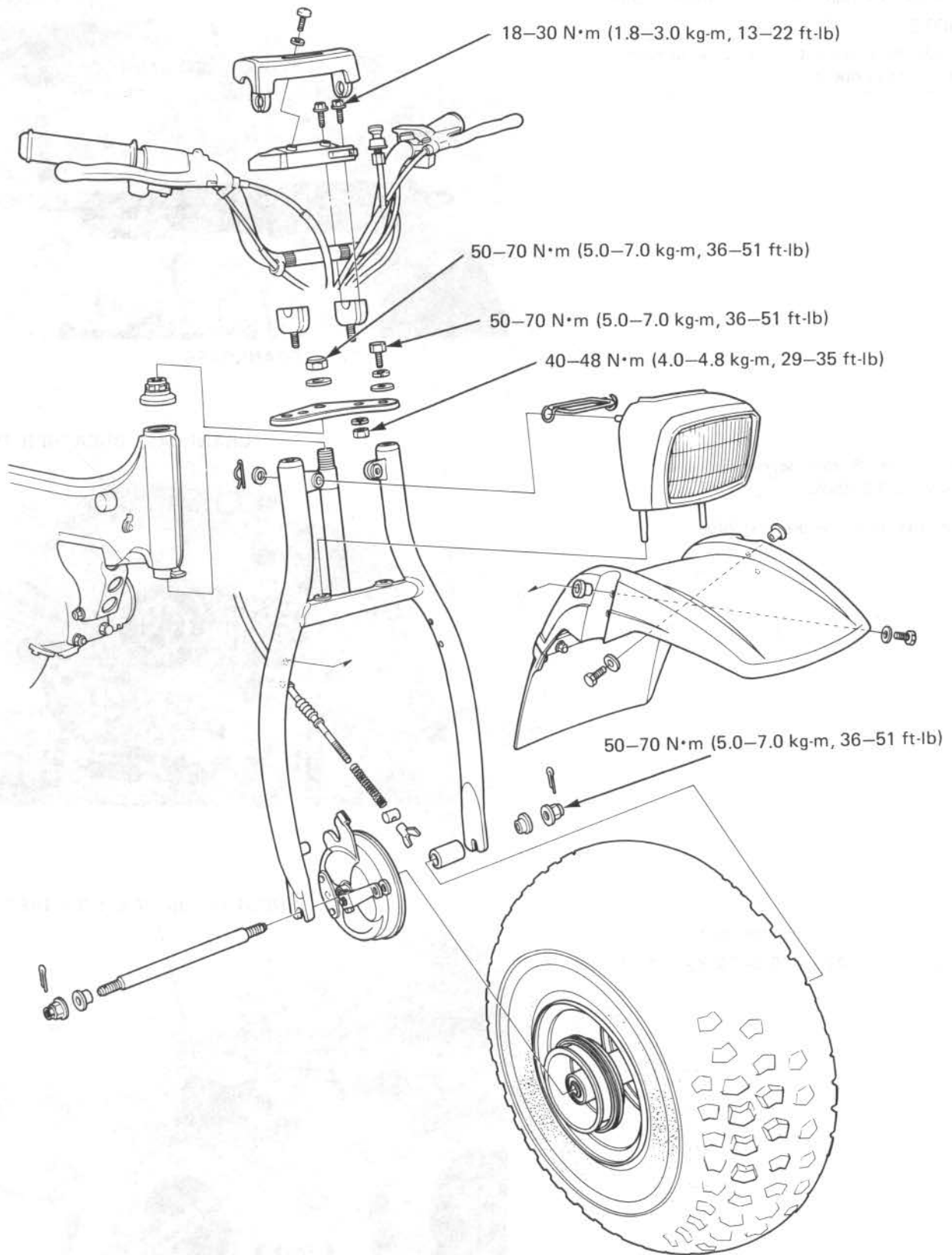

12. FRONT WHEEL/BRAKE/STEERING

SERVICE INFORMATION	12-1
TROUBLESHOOTING	12-2
HANDLEBAR	12-3
THROTTLE LEVER	12-4
FRONT WHEEL	12-6
FRONT BRAKE	12-15
STEERING STEM	12-18

SERVICE INFORMATION

GENERAL

- This section covers maintenance of the front wheel, front brake and steering system.
- A jack or other support is required to support the ATC.

SPECIFICATIONS

ITEM	STANDARD	SERVICE LIMIT
Front axle runout	—	0.5 mm (0.02 in)
Front brake drum I.D.	110 mm (4.3 in)	111 mm (4.4 in)
Front brake lining thickness	4 mm (0.2 in)	2 mm (0.1 in)

TORQUE VALUES

Handlebar upper holder bolt	8 mm	18–30 N-m (1.8–3.0 kg-m, 13–22 ft-lb)
Handlebar lower holder nut	10 mm	40–48 N-m (4.0–4.8 kg-m, 29–35 ft-lb)
Fork bridge bolt	12 mm	50–70 N-m (5.0–7.0 kg-m, 36–51 ft-lb)
Steering stem nut	22 mm	50–70 N-m (5.0–7.0 kg-m, 36–51 ft-lb)
Front axle nut	12 mm	50–70 N-m (5.0–7.0 kg-m, 36–51 ft-lb)
Front wheel hub nut	8 mm	19–25 N-m (1.9–2.5 kg-m, 14–18 ft-lb)

FRONT WHEEL/BRAKE/STEERING

TOOLS

Special

Ball Race Remover	07944-1150001 or M9360-277-91774 (U.S.A. only)
Universal Bead Breaker	GN-AH-958-BB1 (U.S.A. only)
Steering stem driver	07946-GC40000

Common

Driver	07749-0010000 or 07949-6110000
Attachment, 37 x 40 mm	07746-0010200
Pilot, 15 mm	07746-0040300
Attachment, 42 x 47 mm	07746-0010300
Pin Spanner	07702-0020000 or 07902-0010000 or M9361-412-099788 (U.S.A. only)
Lock nut wrench, 30 x 32 mm	07716-0020400 or equivalent commercially available in U.S.A.
Extension bar	07716-0020500 or equivalent commercially available in U.S.A.
TIRE BRAKER SET	07772-0050000
(BRAKER ARM	07772-0050200)
(BRAKER ARM COMPRESSOR	07772-0050100)

TROUBLESHOOTING

Hard steering

1. Steering stem nut too tight
2. Faulty steering stem bearings
3. Damaged steering stem ball race or cone race
4. Insufficient tire pressure

Steers to one side or does not track straight

1. Bent front forks
2. Bent front axle, wheel installed incorrectly

Front wheel wobbling

1. Bent rim
2. Worn front wheel bearing
3. Faulty tire
4. Axle not tightened properly

Improper brake performance

1. Incorrect adjustment of lever
2. Brake shoes worn
3. Brake shoes contaminated
4. Brake cam worn
5. Brake drum worn
6. Brake arm serrations improperly engaged
7. Cam contacting area of shoes worn

Soft suspension

- Weak fork spring

Front suspension noise

- Loosen fork fasteners

HANDLEBAR REMOVAL

Remove the headlight (Page 18-2) and disconnect the wires for the ignition and headlight switches.

Remove the wire bands.
Remove the throttle lever housing.

Remove the front and rear brake lever bracket holders and the brackets.

Loosen the choke cable nut and remove the choke cable from the handlebar upper holder.

Remove the handlebar upper holder cover cap.

Remove the screws attaching the upper holder cover and the cover.

Remove the handlebar holder and handlebar.

INSTALLATION

Place the handlebar on the lower holders.

Align the handlebar punch marks with the top of the handlebar lower holders.

Install the handlebar upper holders on the handlebar.

Tighten the forward bolts first, then tighten the rear bolts.

TORQUE: 18-30 N·m (1.8-3.0 kg-m, 13-22 ft-lb)

Connect the ignition switch and headlight switch wires color-to-color.

Install the headlight.

Connect the brake cables.
Install the throttle lever housing (Page 12-5).

Install the choke cable.
Install the handlebar upper holder cover cap.

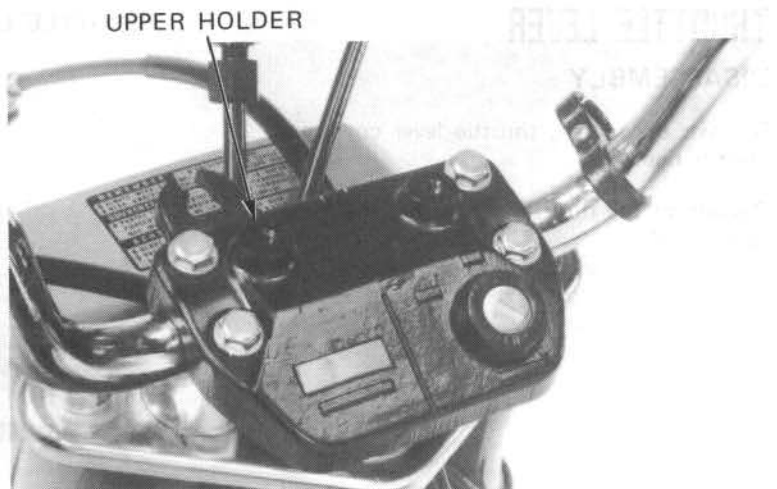
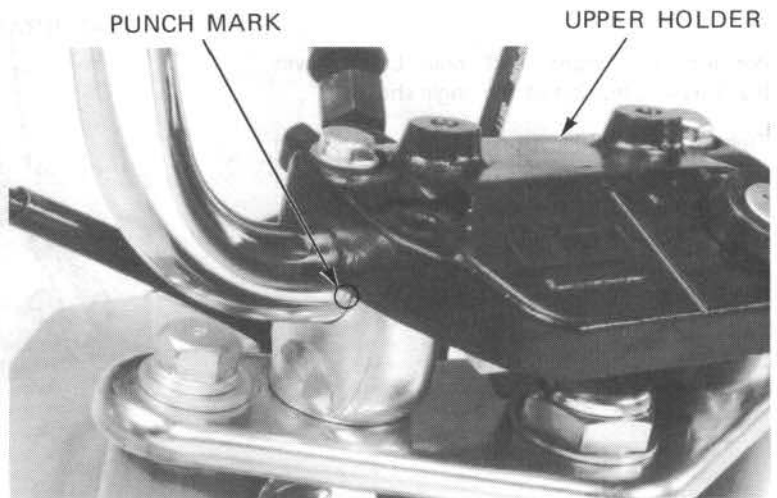
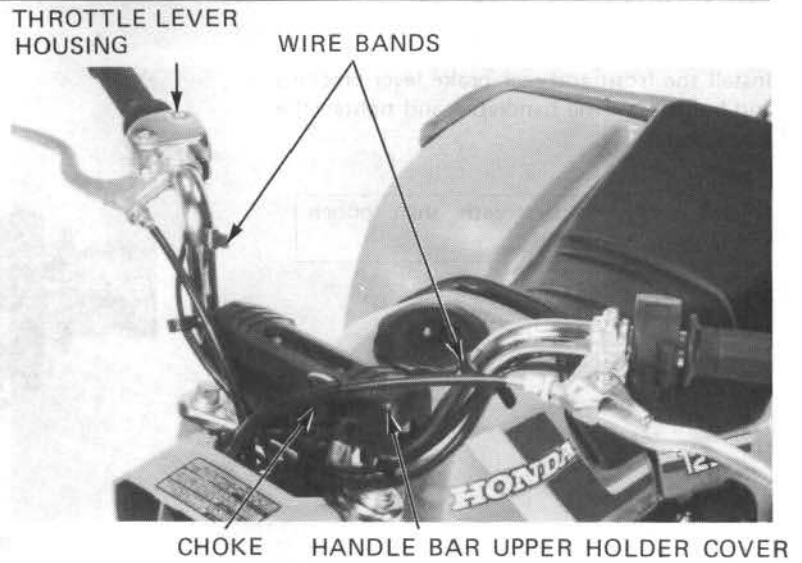

FRONT WHEEL/BRAKE/STEERING

Install the front and rear brake lever brackets and holders on the handlebar and tighten the screws lightly.

NOTE

Install the holders with their punch marks up.

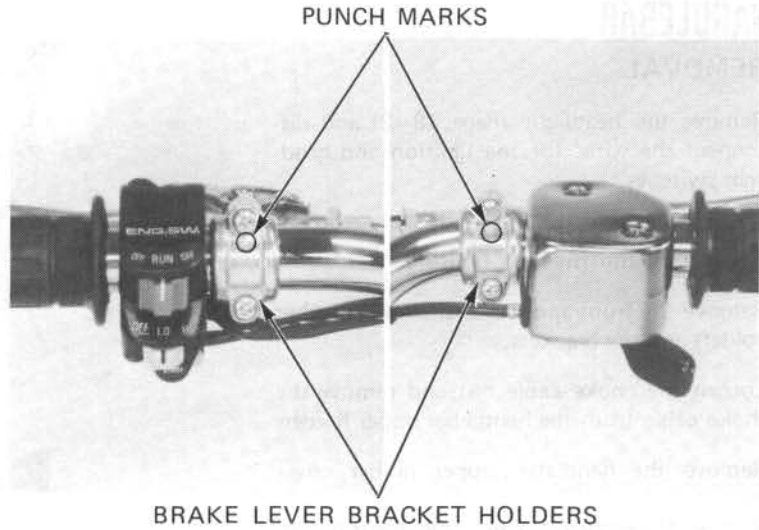

Position the front and rear brake lever brackets and holders at the angle shown.

Tighten the holder upper screw first, then tighten the lower screw.

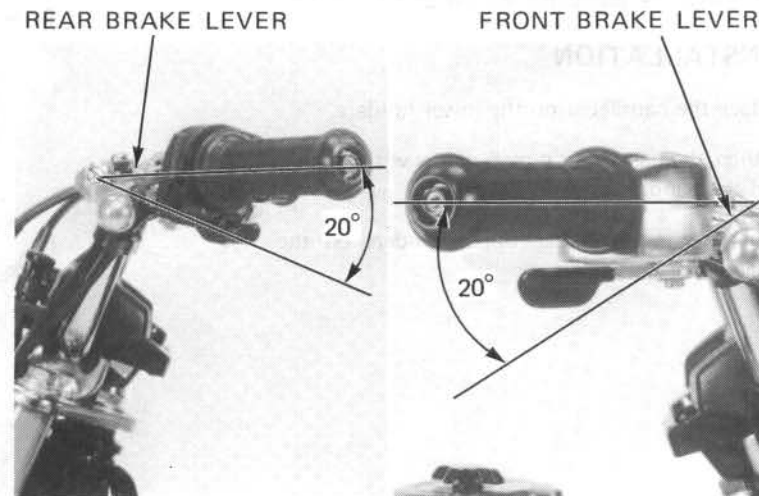

THROTTLE LEVER

DISASSEMBLY

Remove the screws, throttle lever cover and throttle housing.

Disconnect the throttle cable from the throttle housing.

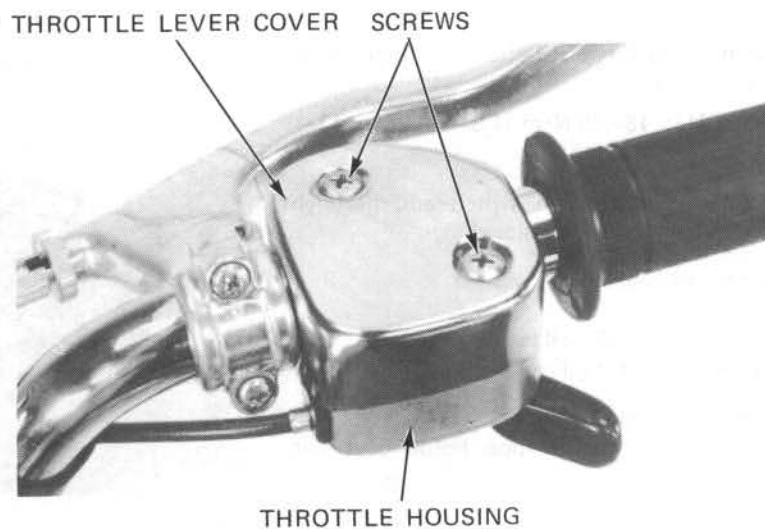

Bend down the lock washer tab and remove the bolt and lock washer. Remove the throttle lever, arm and spring from the throttle housing.

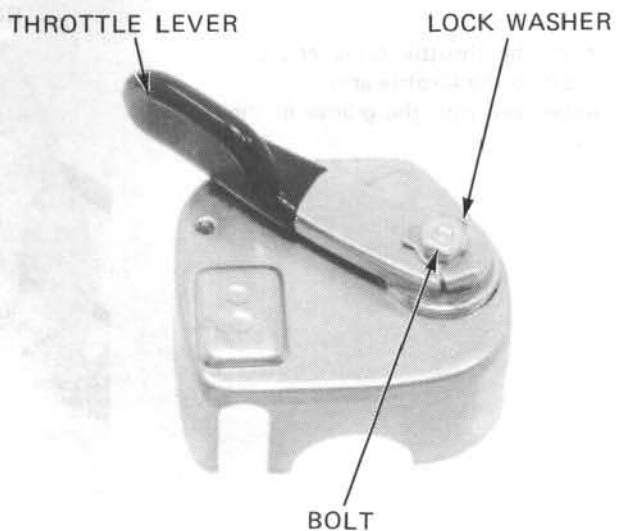

ASSEMBLY

Install the throttle arm, spring and lever into the throttle housing.

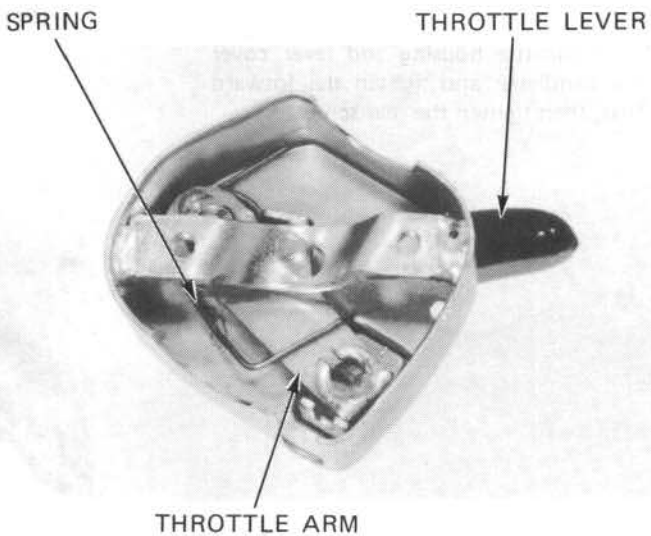

Tighten the throttle lever using the bolt and new lock washer. Bend up the lock washer tab against the bolt head.

Check the lever for smooth operation.

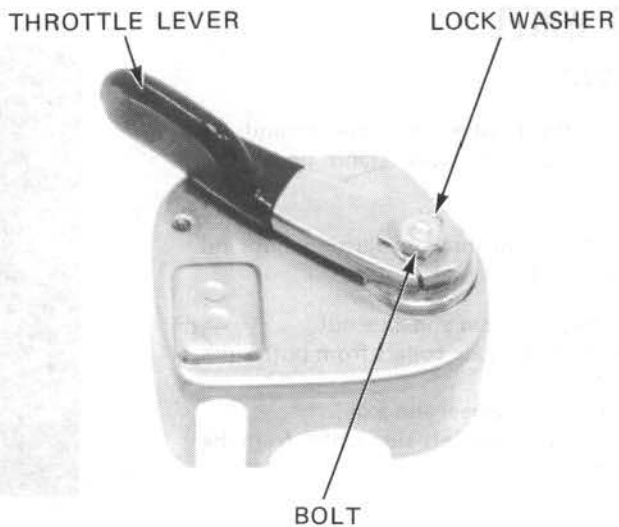

FRONT WHEEL/BRAKE/STEERING

Apply grease to the throttle cable end and connect the cable to the throttle arm. Insert the rubber seal into the groove of the throttle housing.

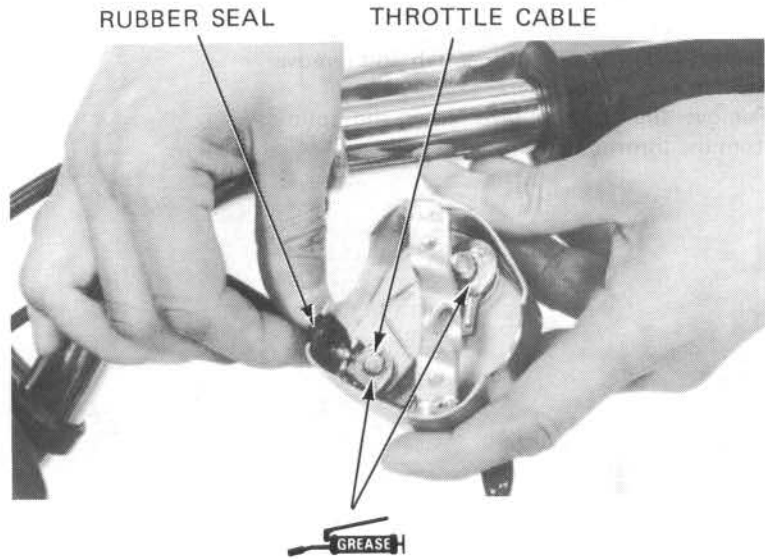

Install the throttle housing and lever cover onto the handlebar and tighten the forward screw first, then tighten the rear screw.

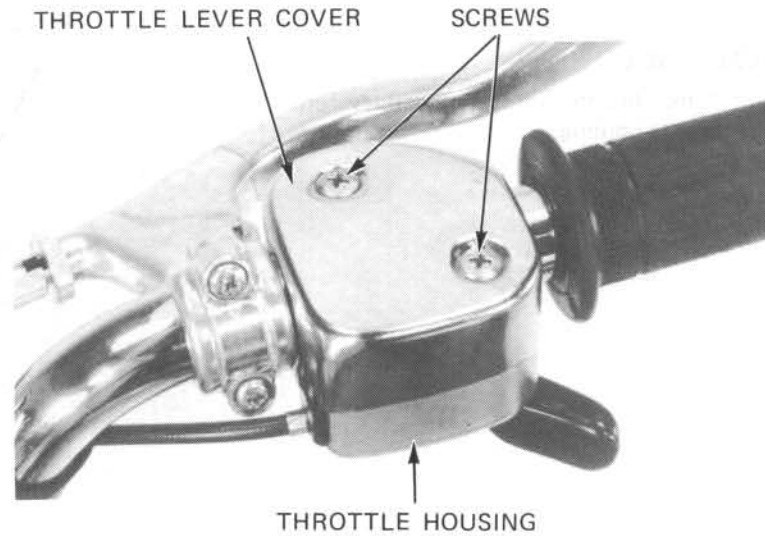

FRONT WHEEL

REMOVAL

Raise the front wheel off the ground by placing a block or work stand under the engine.

Remove the front brake adjusting nut and disconnect the front brake cable.

Remove the cotter pin and axle nut.
Remove the front axle collars from both sides of the axle.
Remove the front wheel and axle.
Remove the axle and left side collar from the wheel hub.

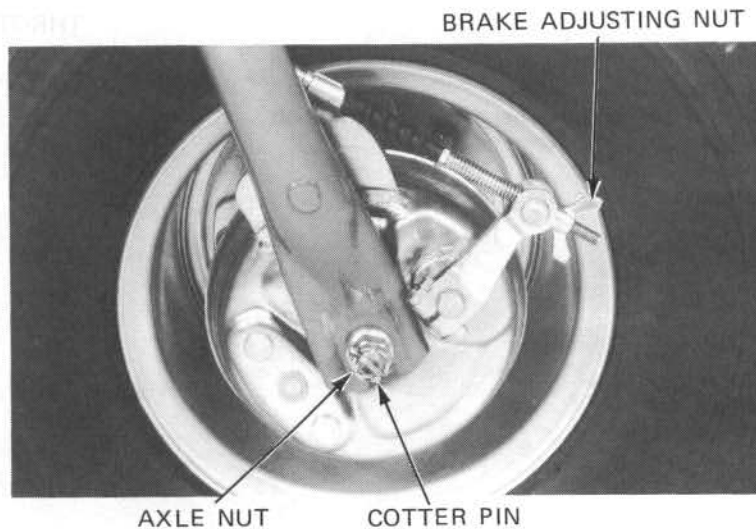

FRONT AXLE INSPECTION

Set the axle in V-blocks, rotate and measure the runout with a dial indicator.

Actual runout is 1/2 of the total indicator reading.

SERVICE LIMIT: 0.5 mm (0.02 in)

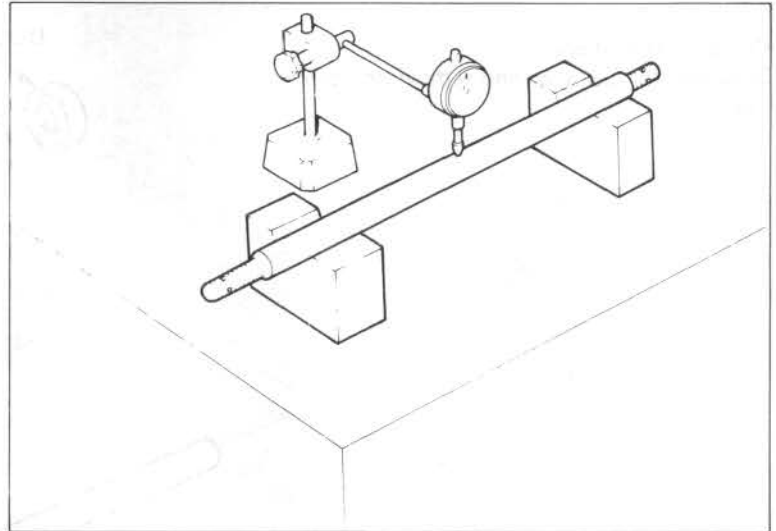

BEARING INSPECTION

Check the wheel bearings by placing the wheel between V-blocks and spinning the wheel by hand.

Replace the bearings with new ones if they are noisy or have excessive play.

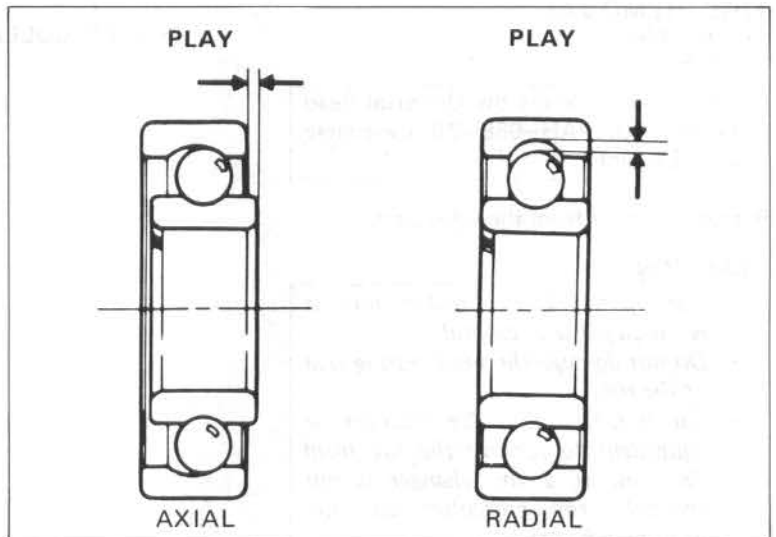

DISASSEMBLY

Remove the front wheel hub nuts and hub.

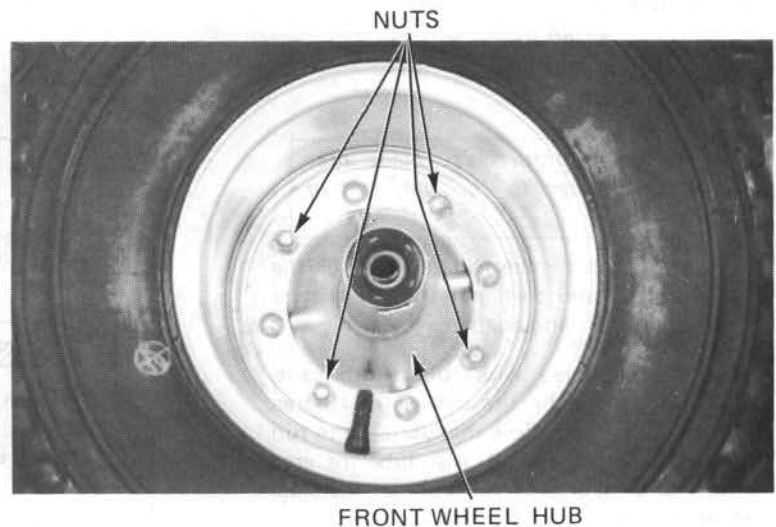

FRONT WHEEL/BRAKE/STEERING

Remove the dust seals.
Drive out the bearings and remove the center collar.

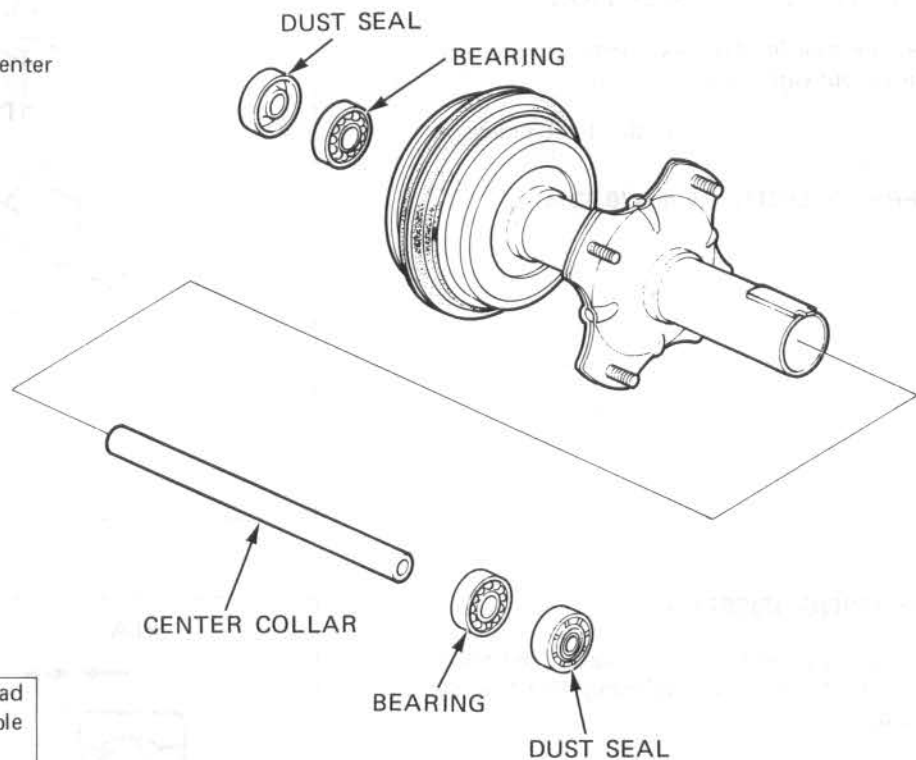

TIRE REMOVAL (U.S.A. only)

NOTE:

This service requires the Universal Bead Breaker (GN-AH-958-BB1) available in U.S.A. only.

Remove the core from the valve stem.

CAUTION

- Use of the Bead Breaker tool is required for tire removal.
- Do not damage the bead seating area of the rim.
- Use a Coats 220 Tire Changer or equivalent to remove the tire from the rim. If a tire changer is not available, rim protectors and tire irons may be used.

Install the proper size blade onto the breaker arm assembly.

Short blade – 7"/8" rims.

Long blade – 9"/11" rims.

CAUTION

Use of an improper size blade may result in damage to the rim, tire or blade.

Place the proper size adapter onto the threaded shaft and then put the wheel over the threaded shaft and adapter.

Lube the bead area with rubber lubricant, pressing down on the tire sidewall/bead area in several places, to allow the lubricant to run into and around the bead. Also lube the area where the breaker arm will contact the sidewall of the tire.

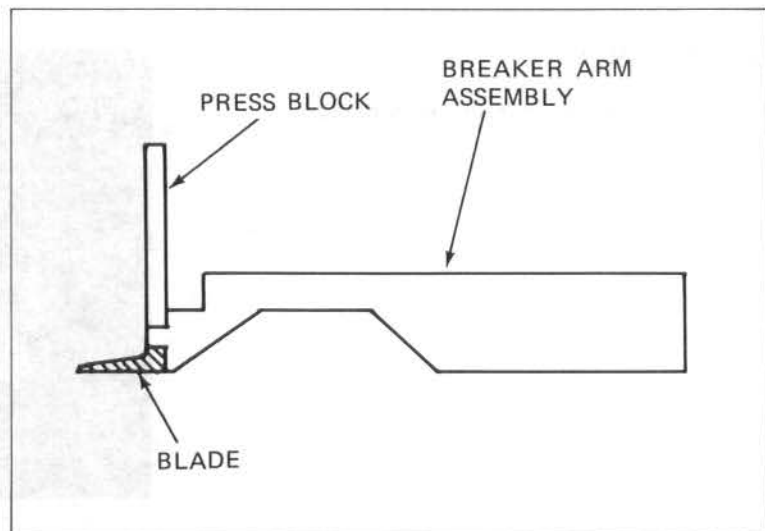

While holding the breaker arm assembly at an approximate 45° position, insert the blade of the breaker arm between the tire and rim. Push the breaker arm inward and downward until it is in the horizontal position with its press block in contact with the rim.

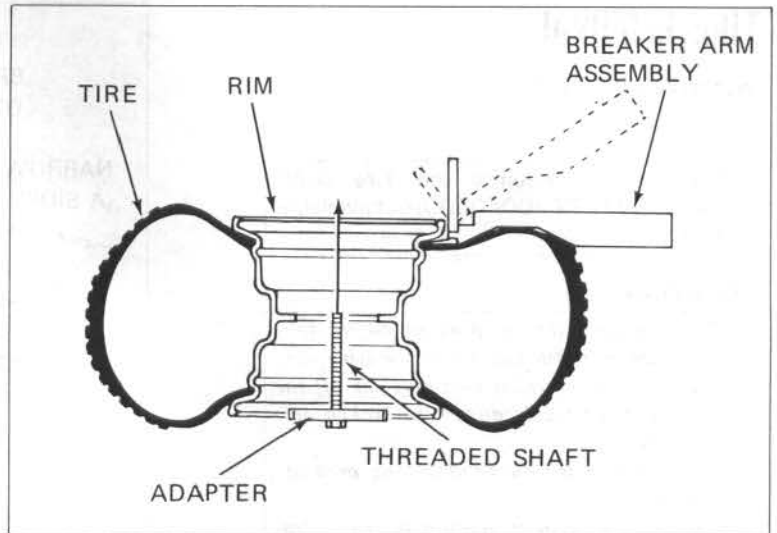

With the breaker arm in the horizontal position, place the breaker press head assembly over the breaker arm press block. Make sure the press head bolt is backed out all the way and then position the nylon buttons on the press head against the inside edge of the rim.

Insert the threaded shaft through the appropriate hole in the breaker press head assembly and then tighten the lever nut until both ends of the breaker press head assembly are in firm contact with the rim.

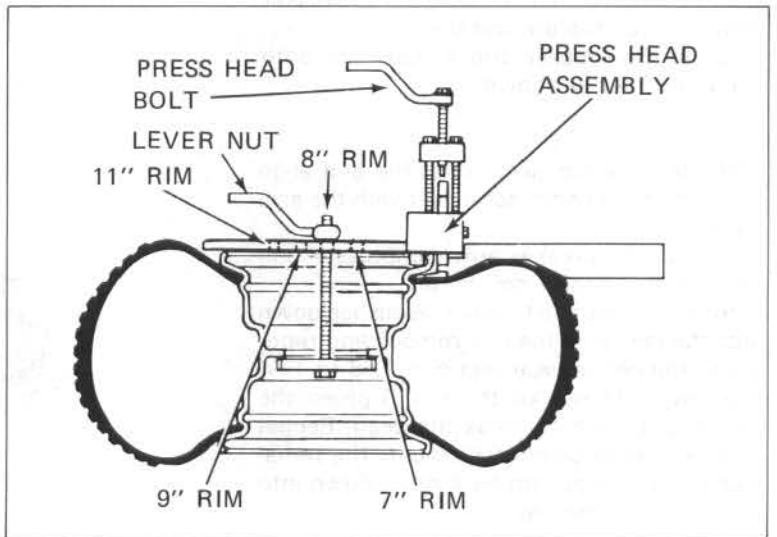

NOTE

Insert bolts through the holes in the rim hub mounting tabs and the adapter to position the adapter properly.

Tighten the press head bolt until the reference mark on the press block is aligned with the top edge of the press head.

If the rest of the bead cannot be pushed down into the center of the rim by hand, loosen the press head bolt and the lever nut. Rotate the breaker arm assembly and breaker press head assembly 1/8 to 1/4 the circumference of the rim. Tighten the lever nut and then tighten the press head bolt as described. Repeat this procedure as necessary until the remainder of the bead can be pushed down into the center of the rim.

Assemble the Universal Bead Breaker on the other side of the wheel and break the bead following the same procedures.

Remove the tire from the rim using a tire changer machine or tire irons and rim protectors.

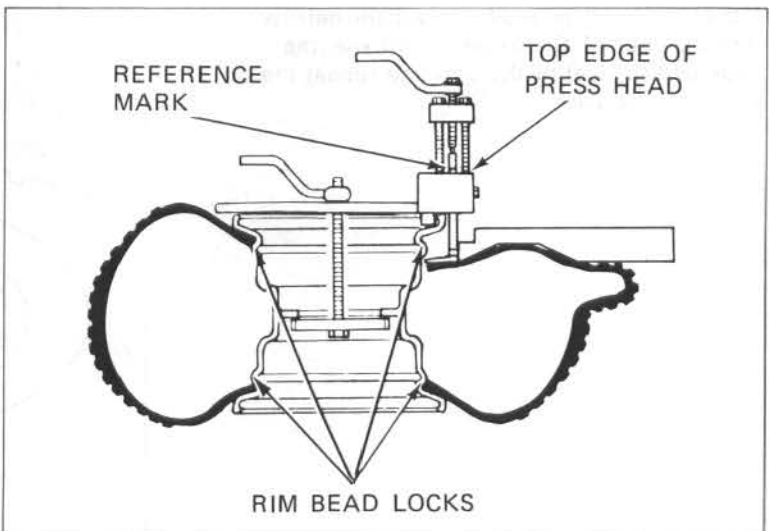

TIRE REMOVAL

(Not available in U.S.A.)

NOTE

This service requires the Tire Bead Breaker (07772-0040000) not available in U.S.A.

CAUTION

Do not apply water, soap water, oil etc. to the tire, rim and tool when removing the tire. The tool breaker arm may slip off the tire and the bead can not be broken off the tire.

- Do not damage the bead seating area of the rim.
- Follow the breaker manufacturer's instructions.

Insert the narrow end (A side) of the breaker arm between the tire and the rim. Position the breaker arm compressor onto the rim center as shown.

Keep the breaker arm horizontal and align the end of the compressor bolt with the arm hole. Screw in the breaker arm compressor bolt to break the bead from the tire. If the rest of the bead cannot be pushed down into the center of the rim remove and reposition the compressor and arm $1/8$ to $1/4$ the circumference of the rim. Tighten the compressor bolt to break the bead. Repeat this procedure as necessary until the remainder of the bead can be pushed down into the center of the rim.

If the bead breaking is difficult with the narrow end (A side) of the breaker arm, use the wide end (B side) of the arm and repeat the procedure above.

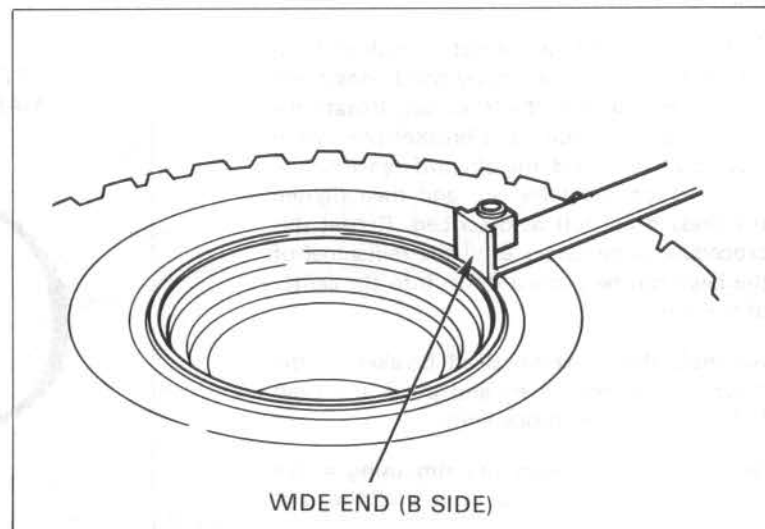
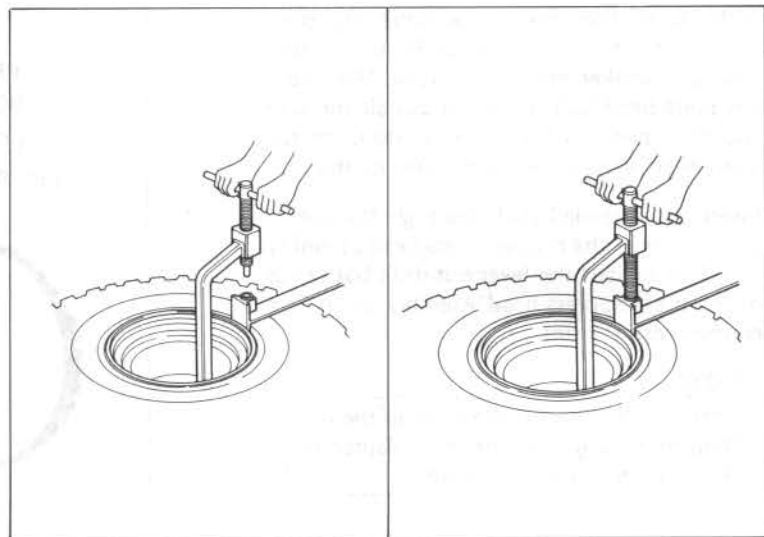
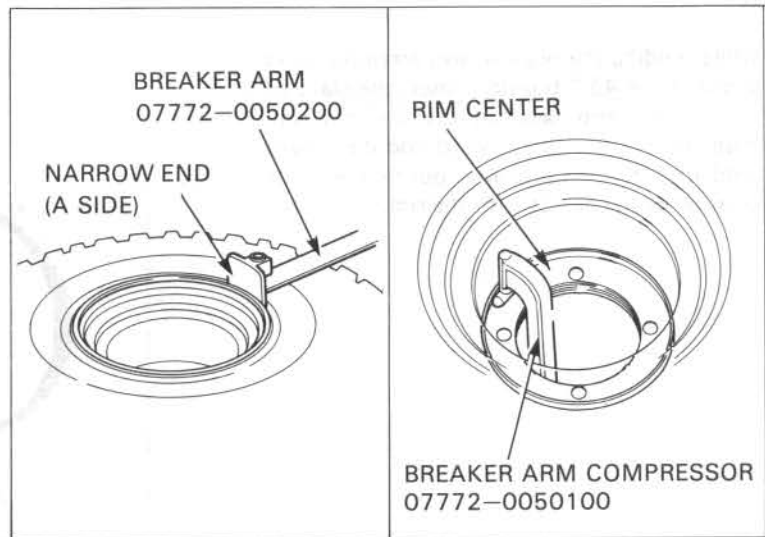

TIRE REPAIR

NOTE:

Use the manufacturer's instructions for the tire repair kit you are using. If your kit does not have instructions, the procedures provided here.

Check the tire for puncturing objects. Chalk mark the punctured area and remove the puncturing object.

Inspect and measure the injury. Tire repairs for injuries larger than 15 mm (5/8 in) should be a section repair. Section repairs should be done by a professional tire repair shop.

If the injury is smaller than 15 mm (5/8 in), proceed with the repair as described here.

Install a rubber plug into the injury as follows.

Apply cement to a plug inserting needle and work the needle into the injury to clean and lubricate it. Do this three times. Do not let the cement dry.

Insert and center a rubber plug through the eye of the inserting needle.

Apply cement to the rubber plug. Push the inserting needle with plug into the injury until the plug is slightly above the tire. Twist the needle and remove it from the tire, the plug will stay in the tire.

NOTE:

Be careful not to push the plug all the way into the tire to prevent it from falling into the tire.

Trim the plug to 6 mm (1/4 in) above the tire surface.

Repeat the above procedure if the puncture is large. Do not use more than two plugs per injury.

Allow the repair to dry. Drying time will vary with air temperature. Refer to the tire repair kit manufacturer's recommendations.

Inflate the tire and test the seal by dabbing a small amount of cement around the plug. Escaping air will cause a bubble in the cement. If there is leakage, remove the tire (page 12-8) and apply a cold patch to the inside of the tire as described.

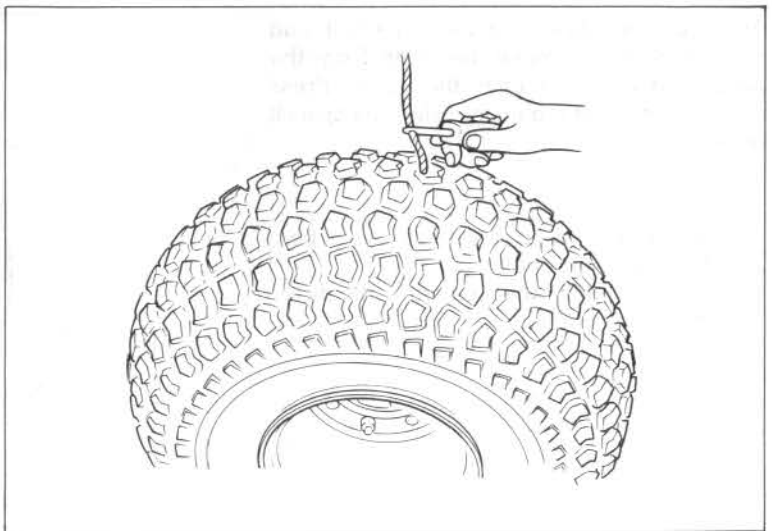
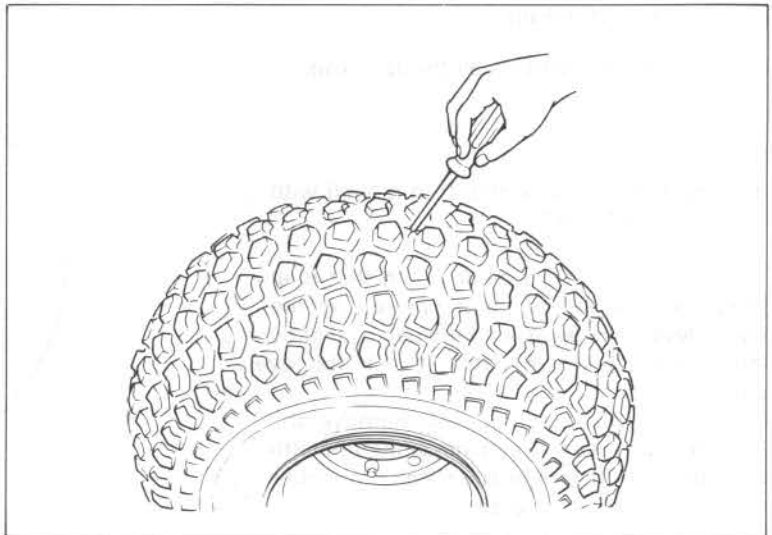
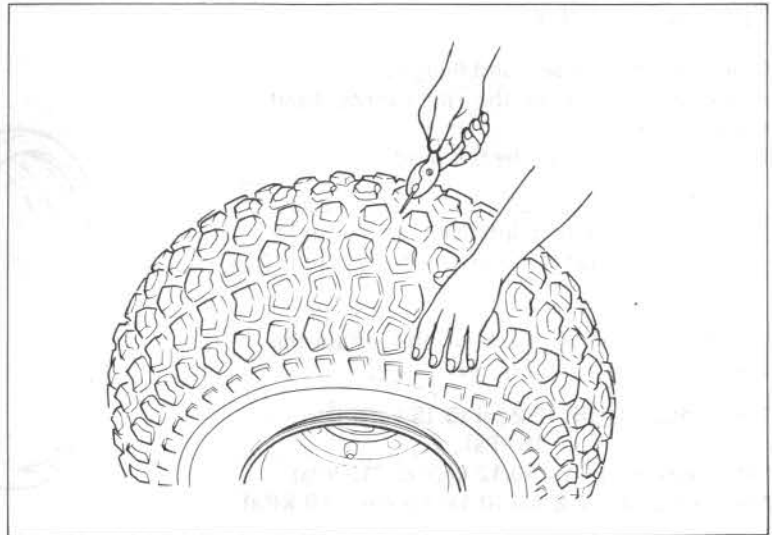

FRONT WHEEL/BRAKE/STEERING

TIRE ASSEMBLY

Clean the rim bead seat and flanges.
Apply clean water to the rim flanges, bead seat and base.

Inflate the tire to seat the tire bead.

NOTE

Use tire mounting lubricant or a soap and water solution to help seat the tire bead.

Deflate the tire. Wait 1 hour and inflate the tire to the specified pressure.

TIRE PRESSURE: 2.2 psi (0.15 kg/cm², 15 kPa)

Min. Pressure: 1.7 psi (0.12 kg/cm², 12 kPa)

Max. Pressure: 2.6 psi (0.18 kg/cm², 18 kPa)

Measure the tire circumference.

**STANDARD TIRE CIRCUMFERENCE:
1,742 mm (68.6 in)**

Check for air leaks and install the valve cap.

If a plug has been inserted, trim it even with the inner tire surface.

Temporarily place a rubber patch that is at least twice the size of the puncture over the injury. Make a mark around the patch, slightly larger than the patch itself. Remove patch.

larger than the patch it self. Remove the Roughen the area marked inside the tire with a tire buffer or a wire brush. Clean the rubber dust from the buffed area.

Apply cement over the area marked and allow it to dry. Remove the lining from the patch and center it over the injury. Press the patch against the injury using the special roller.

NOTE:

- Allow cement to dry until tacky before applying patch.
- Do not touch the cement with dirty or greasy hands.

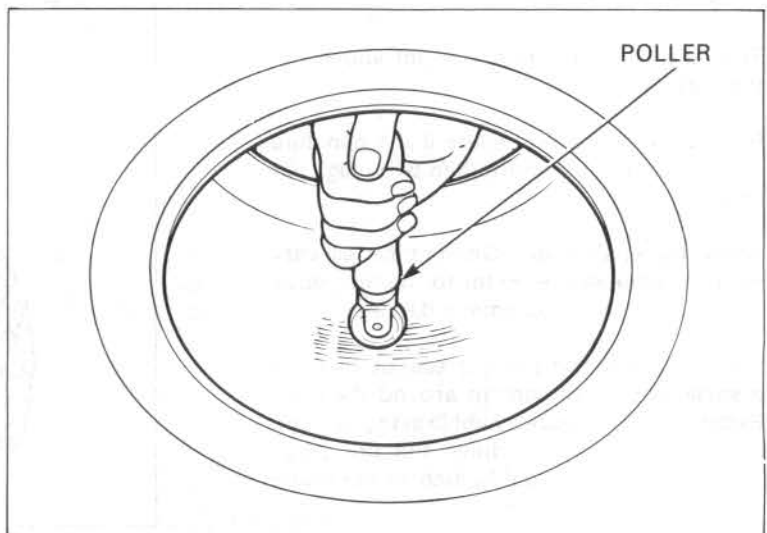
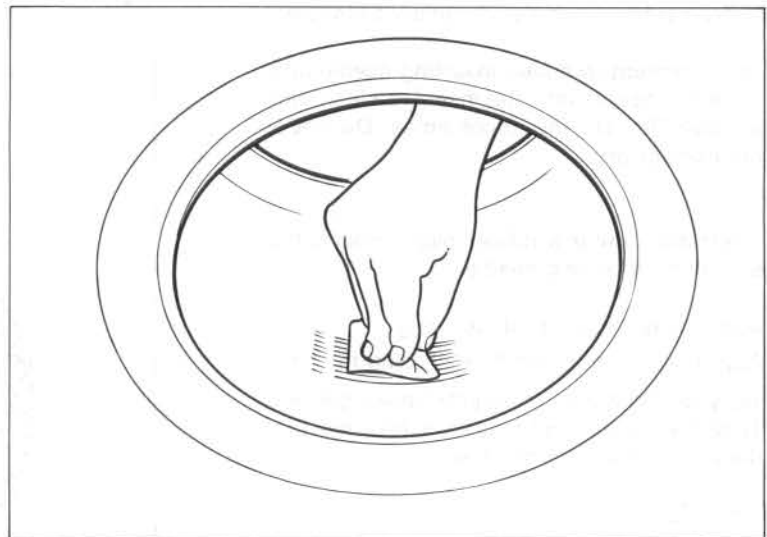
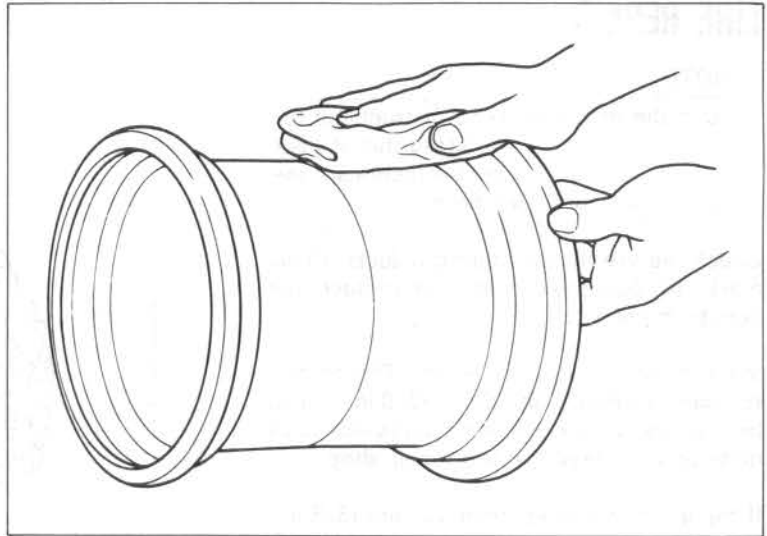

FRONT WHEEL ASSEMBLY

Pack all front wheel bearing cavities with grease.

Drive in the left bearing squarely until it seats.

Install the center collar and drive in the right bearing squarely until it seats.

NOTE

Do not allow the bearings to tilt while driving them in.

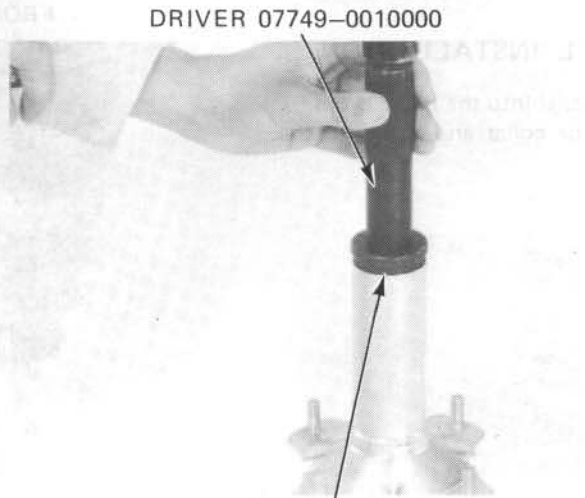

DRIVER 07749-0010000

ATTACHMENT, 42 x 47 mm 07746-0010300
PILOT, 15 mm 07746-0040300

Apply grease to the inside of the dust seals and install them into the wheel hub.

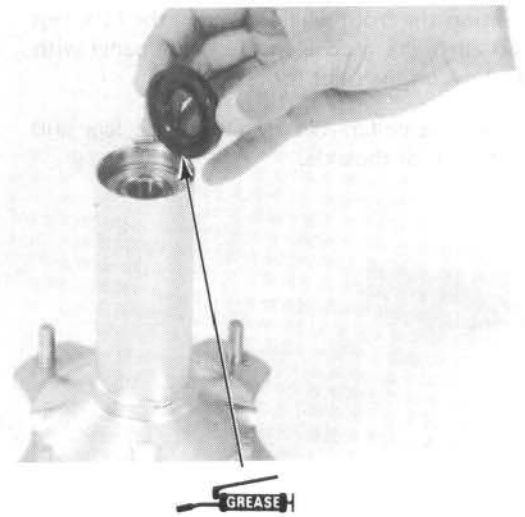

Install the front wheel hub and tighten the hub nuts.

TORQUE:

19-25 N·m (1.9-2.5 kg-m, 14-18 ft-lb)

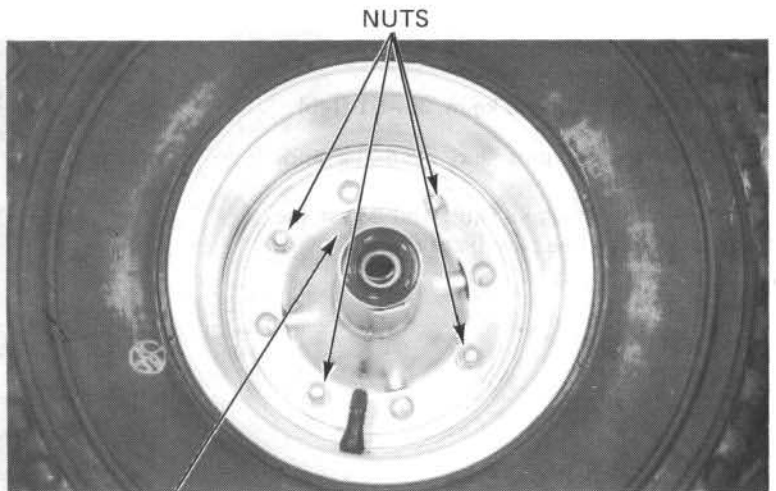

NUTS

WHEEL HUB

FRONT WHEEL INSTALLATION

Install the brake panel into the brake drum.
Install the left side collar and axle into the wheel hub.

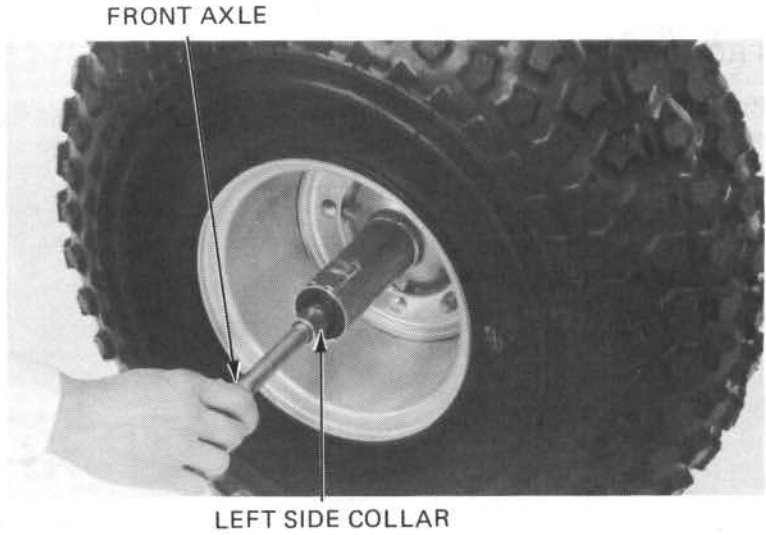

Position the front wheel between the fork legs and align the groove in the brake panel with the boss on the right fork leg.

Install the collars between the fork legs and both ends of the axle.

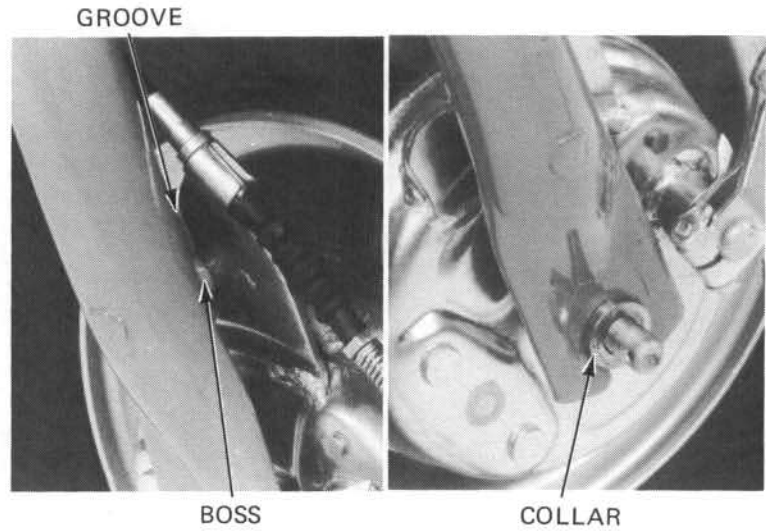

Tighten the axle nuts.

TORQUE:

50–70 N·m (5.0–7.0 kg-m, 36–51 ft-lb)

Install new cotter pins and bend the ends securely.

Connect the front brake cable and adjust the front brake lever free play (Page 3–14).

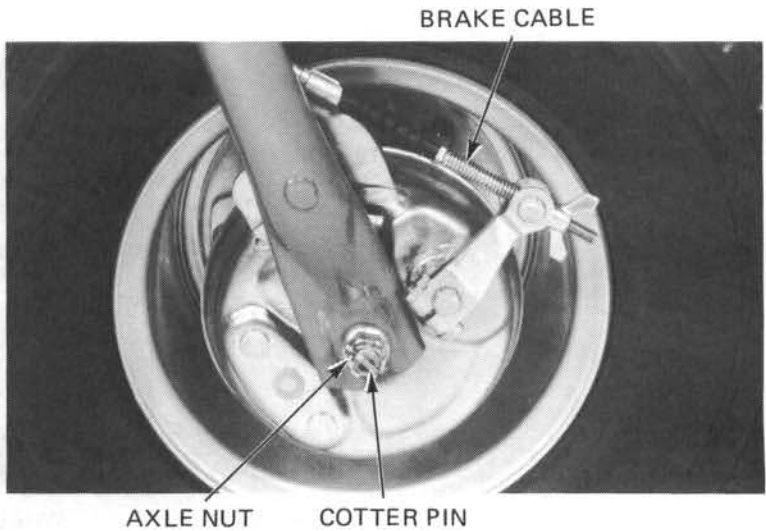

FRONT BRAKE

REMOVAL

Remove the front wheel (Page 12-6).
Remove the brake panel from the wheel.

BRAKE DRUM INSPECTION

Remove the brake panel assembly and
measure the brake drum I. D.

SERVICE LIMIT: 111 mm (4.4 in)

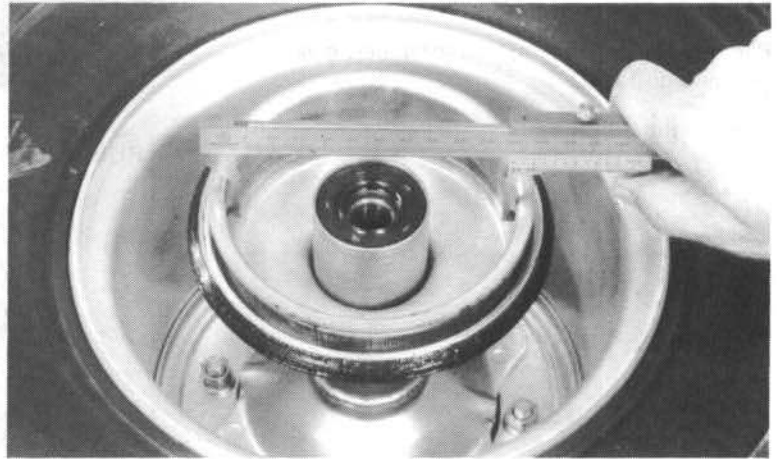

BRAKE LINING INSPECTION

Measure the brake lining thickness.

SERVICE LIMIT: 2 mm (0.1 in)

Replace the brake linings if they are thinner
than the service limit.

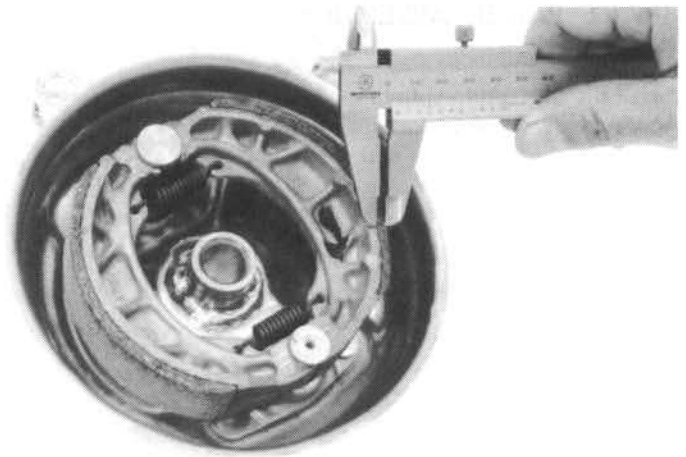

BRAKE PANEL DISASSEMBLY

Expand and remove the brake shoes by hand.

BRAKE SHOES SHOE SPRINGS

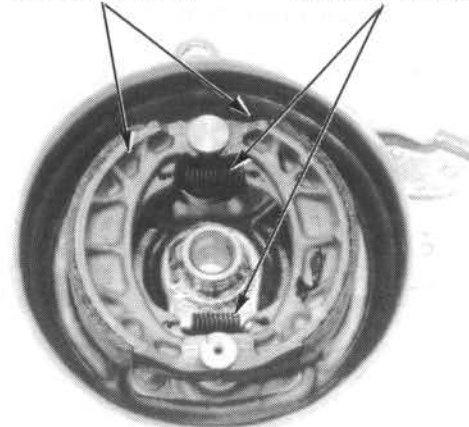

FRONT WHEEL/BRAKE/STEERING

Remove the brake arm bolt, brake arm and indicator plate.

Remove the brake cam, thrust washer, grease seals and dust seal.

Remove the rubber seal.

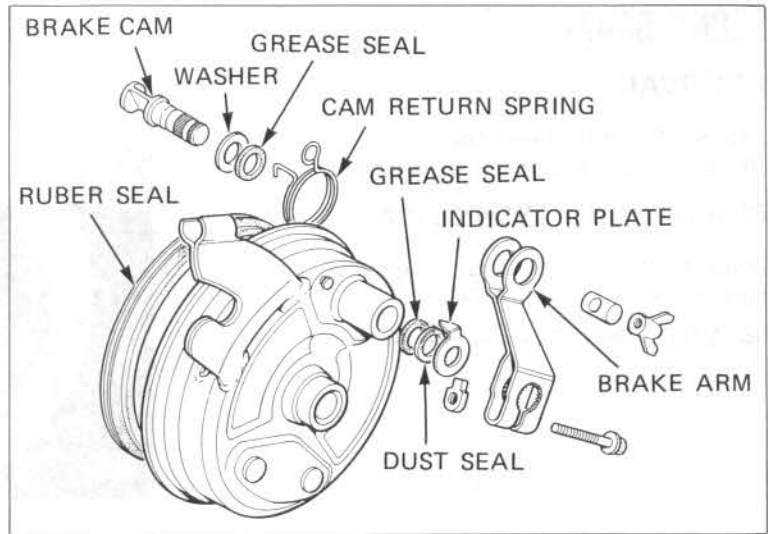

BRAKE PANEL ASSEMBLY

Install new rubber and grease seals.

Install the cam return spring.

Apply grease to the brake cam and anchor pin and insert the brake cam and washer onto the brake panel.

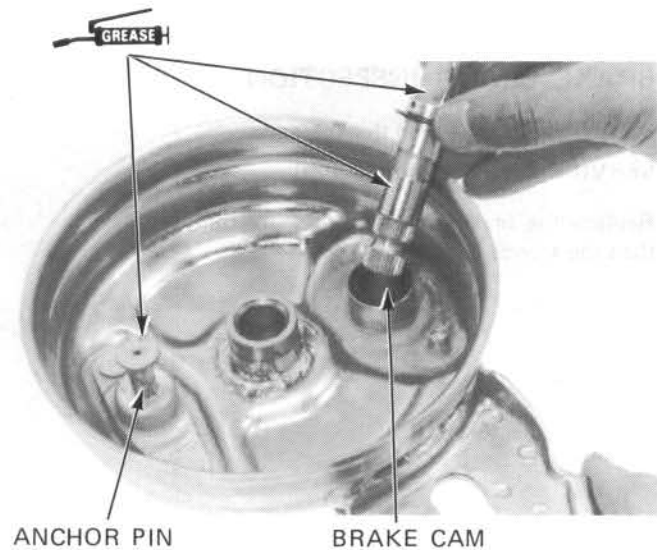

Insert the end of the spring into the hole in the brake cam.

Install the dust seal.

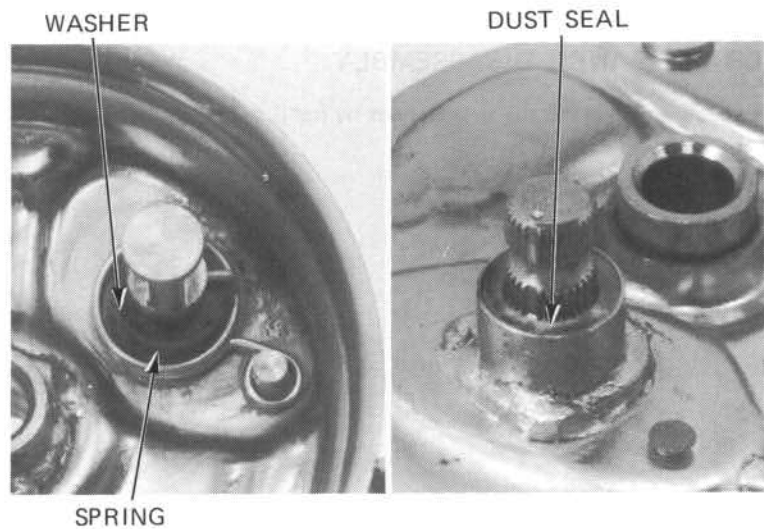

Install the wear indicator plate onto the brake cam by aligning the indicator tab with the cut-out in the brake camshaft.

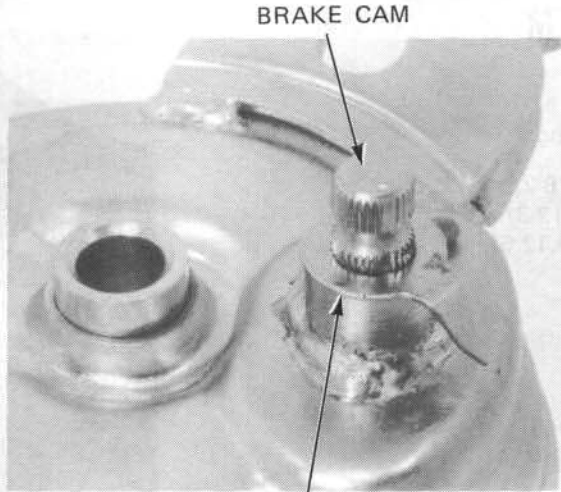

WEAR INDICATOR PLATE

Install the brake arm aligning the punch marks. Torque the brake arm bolt.

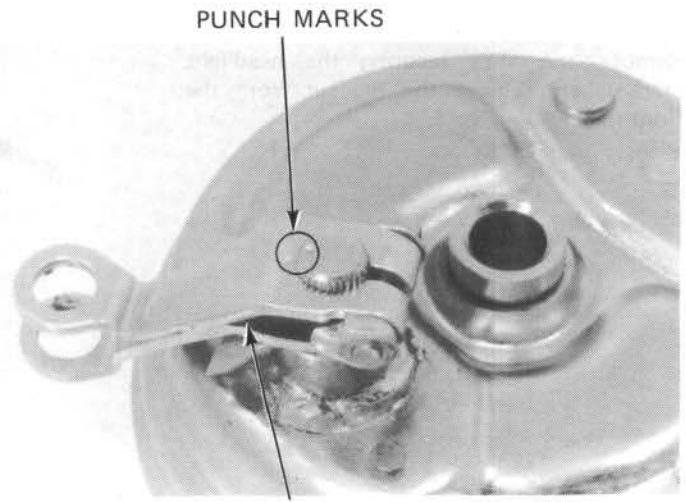

BRAKE ARM

Install the brake shoes and springs onto the brake panel.

WARNING

- *A contaminated brake lining reduces stopping power.*
- *Keep grease off the linings. Wipe excess grease off the cam.*

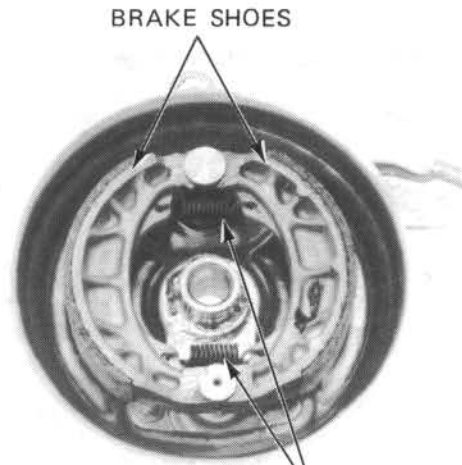

SHOE SPRINGS

STEERING STEM

REMOVAL

Remove the following:

- headlight (Page 18-2).
- handlebar (Page 12-3).
- from wheel (Page 12-6).
- front fender.

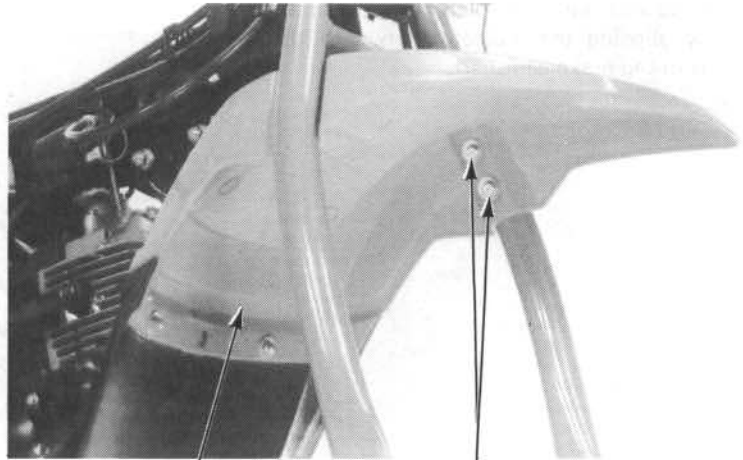

FRONT FENDER

BOLTS

Remove the clips securing the headlight bracket and remove the bracket from the front fork.

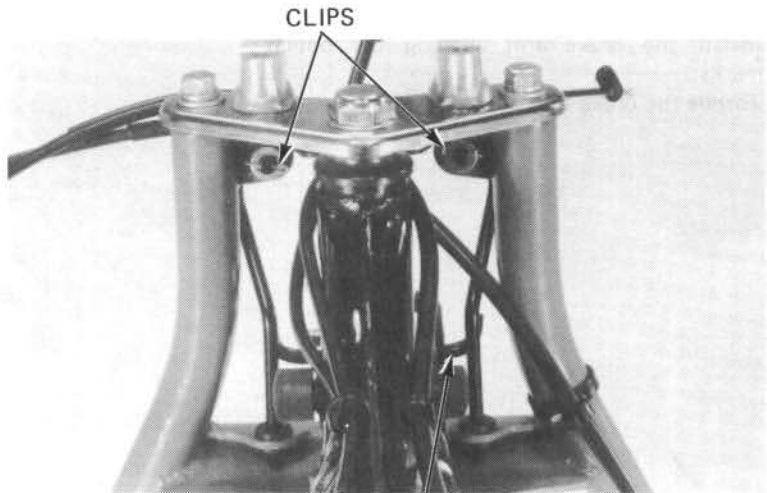

CLIPS

HEADLIGHT BRACKET

Remove the steering stem nut and fork bridge bolts.
Remove the fork bridge.

EXTENSION BAR 07716-0020500 or commercially available
LOCK NUT WRENCH, 30 x 32 mm 07716-0020400 or commercially available in U.S.A.

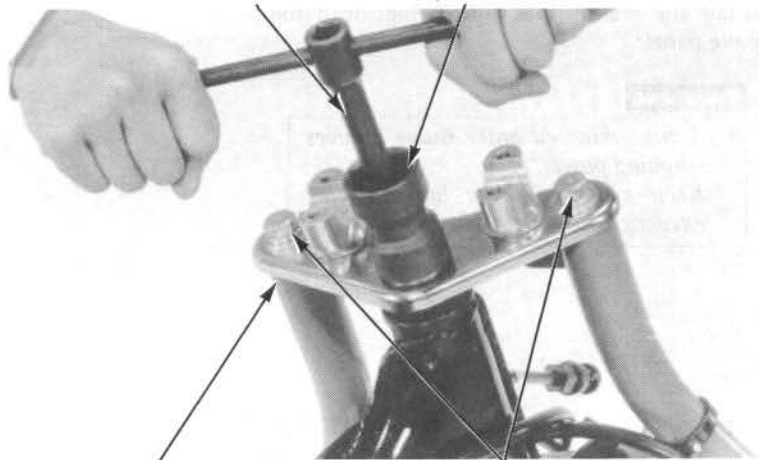

FORK BRIDGE

BOLTS

Remove the steering adjustment nut using the special tool.

LOCK NUT WRENCH, 26 x 30 mm 07716-0020203 or equivalent commercially available in U.S.A.

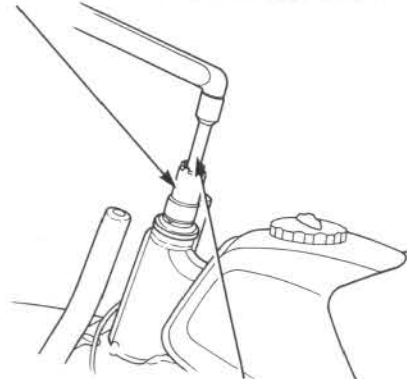

EXTENSION BAR 07716-0020500 or equivalent commercially available in U.S.A.

Remove the top cone race, ball bearings and front fork being careful not to drop the bearings.

TOP CONE RACE

BALL BEARINGS

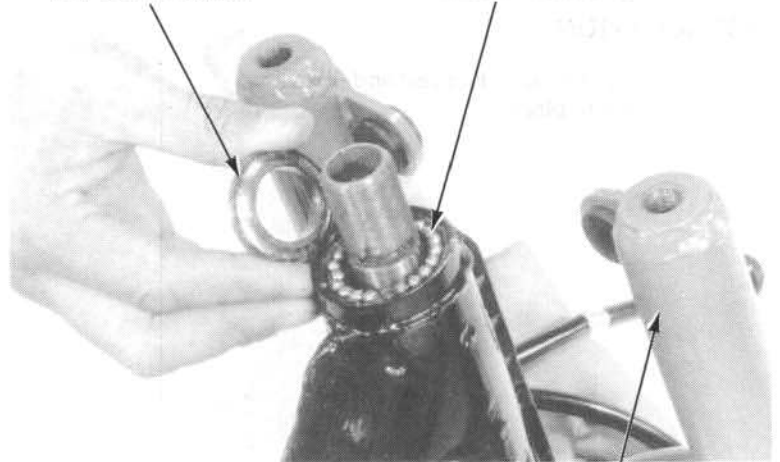

FRONT FORK

Check the ball races for wear or damage and remove if necessary.

BALL RACE REMOVER

07944-1150001 or M9360-277-91774 (U.S.A. only)

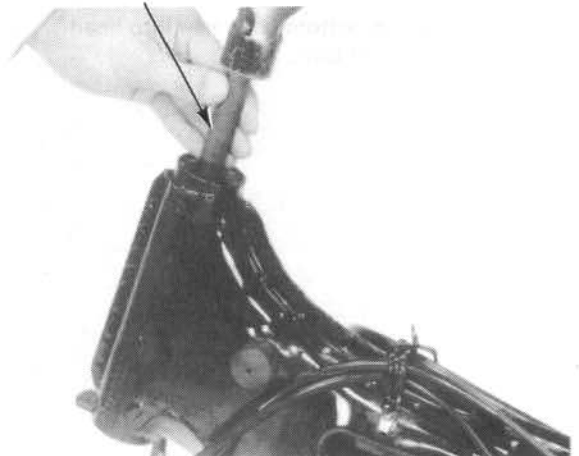

FRONT WHEEL/BRAKE/STEERING

Inspect the bottom cone race for wear or damage and replace if necessary.
Remove the bottom cone race with a hammer and a drift.

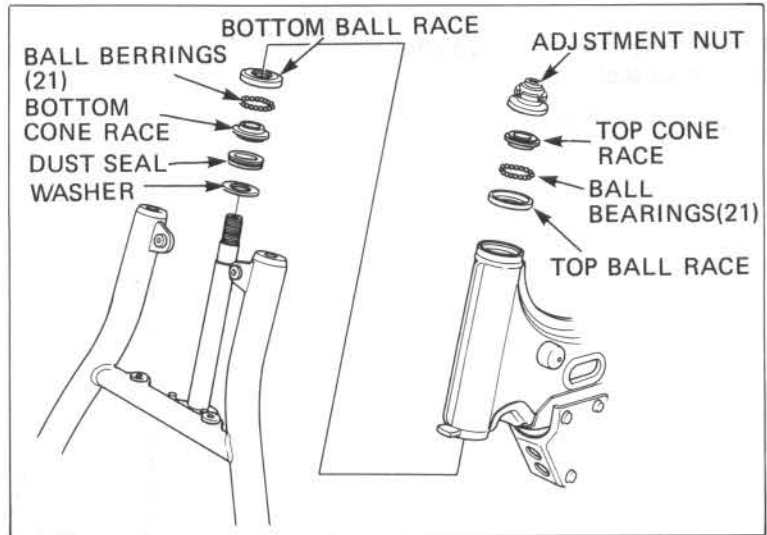

INSTALLATION

Install a new washer and dust seal and drive a new cone race into place.

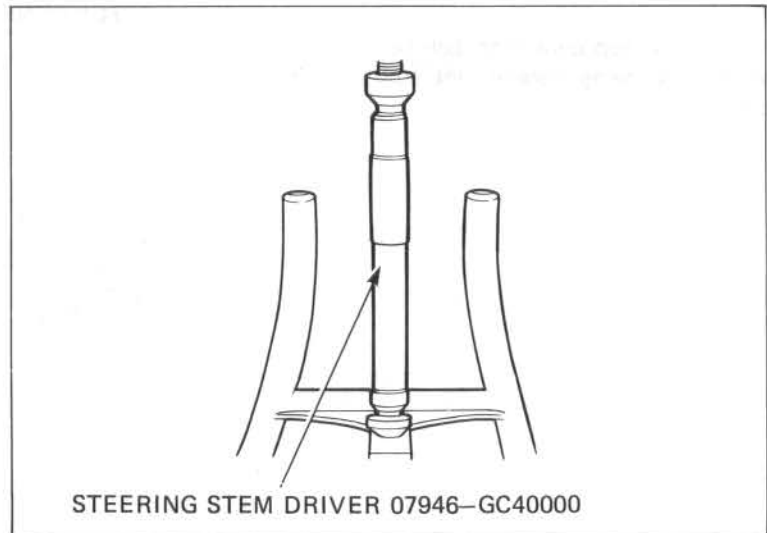

Drive new top and bottom ball races into head pipe with the special tools.

DRIVER 07749-0010000



ATTACHMENT, 37 x 40 mm 07746-0010200

Apply grease to the top and bottom ball races and install 21 ball bearings for both the top and bottom ball races.

Insert the steering stem into the steering head pipe and install the top cone race.

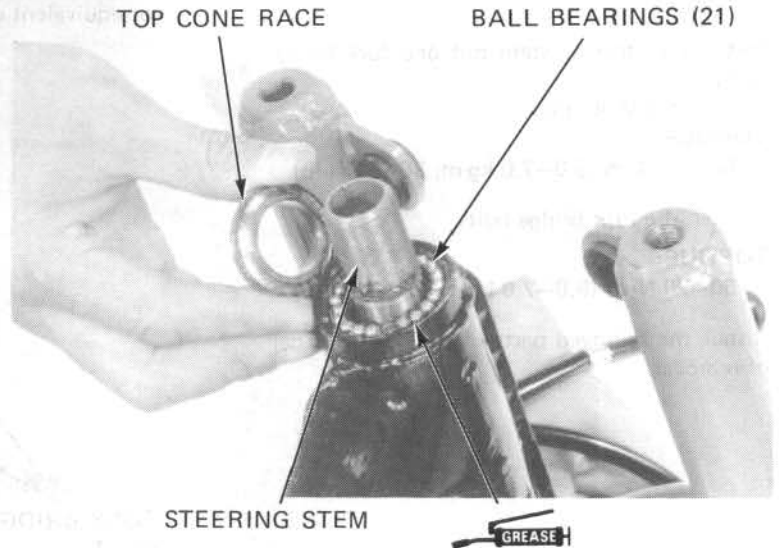

Install the bearing adjustment nut and tighten it with first torque.

TORQUE: 25–35 N·m
(2.5–3.5 kg-m, 18–25 ft-lb)

LOCK NUT WRENCH, 26 x 30 mm 07716–0020203 or equivalent commercially available in U.S.A.

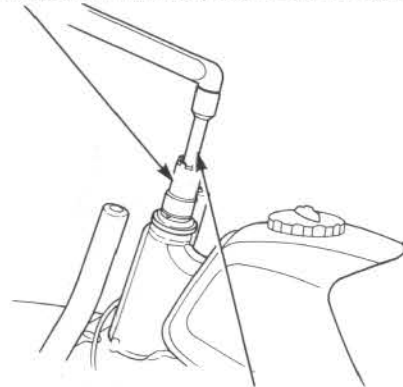

EXTENSION BAR 07716–0020500 or equivalent commercially available in U.S.A.

Turn the steering stem lock-to-lock 4–5 times to seat the bearings.

Completely loosen the bearing adjustment nut, then retighten the adjustment nut to final torque.

TORQUE: 6–7 N·m
(0.6–0.7 kg-m, 4.3–5.1 ft-lb)

Make sure that there is no vertical movement and that the stem rotates freely.

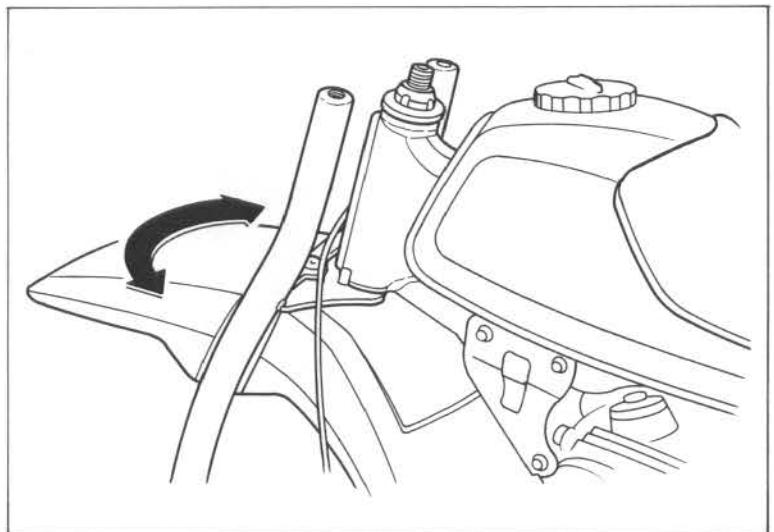

FRONT WHEEL/BRAKE/STEERING

Install the steering stem nut and fork bridge bolts.

Tighten the stem nut.

TORQUE:

50–70 N·m (5.0–7.0 kg-m, 36–51 ft-lb)

Tighten the fork bridge bolts.

TORQUE:

50–70 N·m (5.0–7.0 kg-m, 36–51 ft-lb)

Install the removed parts in the reverse order of removal.

LOCK NUT WRENCH, 30 x 32 mm 07716–0020400
or equivalent commercially available in U.S.A.

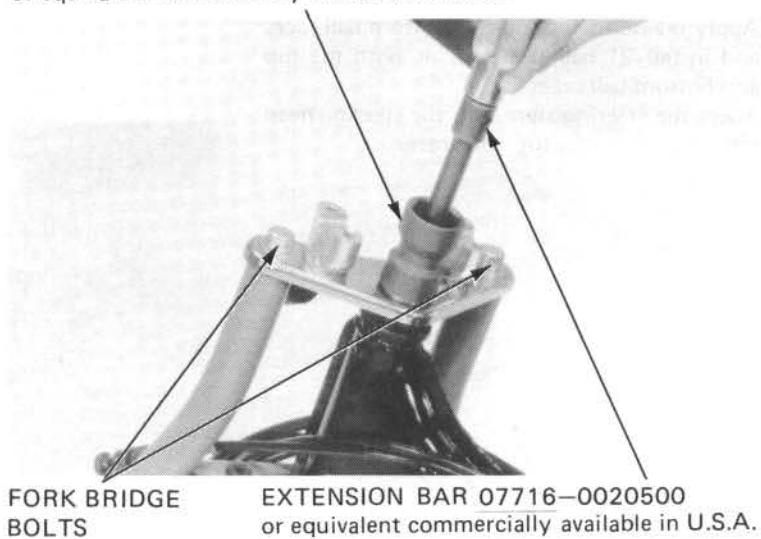

MEMO

(Date) 201-11-15

To: Mr. M. T. S. (M. T. S.)



WHEEL
BRAKE

1/20



REAR WHEEL/BRAKE/DRIVE MECHANISM

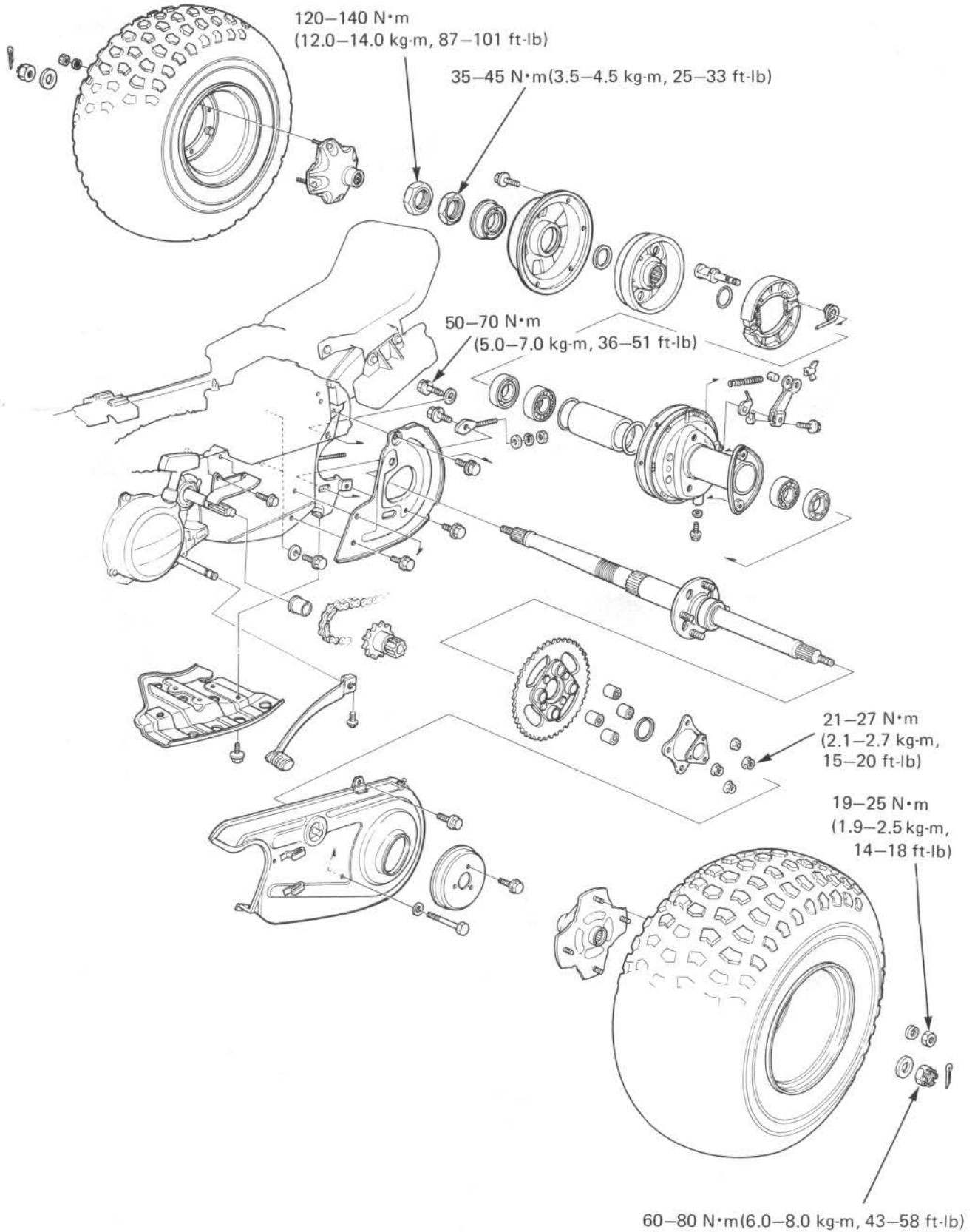

13. REAR WHEEL/BRAKE/ DRIVE MECHANISM

SERVICE INFORMATION	13-1
TROUBLESHOOTING	13-2
REAR WHEEL	13-3
REAR AXLE/FINAL DRIVEN SPROCKET	13-4
REAR BRAKE	13-13
REAR AXLE BEARING HOLDER	13-15
BRAKE PEDAL	13-18

SERVICE INFORMATION

GENERAL

- This section covers maintenance of the rear wheel and drive mechanism.
- A jack or block is required to support the ATC.
- Refer to section 12 for tire servicing.

SPECIFICATIONS

ITEM	STANDARD	SERVICE LIMIT
Rear axle runout	_____	3.0 mm (0.12 in)
Rear brake drum I.D.	140 mm (5.5 in)	141 mm (5.6 in)
Rear brake lining thickness	4 mm (0.2 in)	2 mm (0.1 in)

TORQUE VALUES

Damper holder nut		21-27 N-m (2.1-27. kg-m, 15-20 ft-lb)
Rear brake drum nut	INNER NUT	35-45 N-m (3.5-4.5 kg-m, 25-33 ft-lb)
	OUTER NUT	120-140 N-m (12.0-14.0 kg-m, 87-101 ft-lb)
Rear wheel hub nut		19-25 N-m (1.9-2.5 kg-m, 14-18 ft-lb)
Rear axle bearing holder bolt		50-70 N-m (5.0-7.0 kg-m, 36-51 ft-lb)
Rear axle nut		60-80 N-m (6.0-8.0 kg-m, 43-58 ft-lb)

TOOLS

Special

Axle nut torque wrench adapter	07916-958010A	} U.S.A. only
Axle nut holder wrench	07916-958020A	
Open end wrench, 41mm	07916-9580200	} Not available U.S.A.
Lock nut wrench, 41mm	07916-9580300	

Common

Attachment, 62 x 68 mm	07746-0010500
Driver	07749-0010000
Pilot, 35 mm	07746-0040800

TROUBLESHOOTING

Wobble or vibration in ATC

1. Bent rim
2. Loose wheel bearing
3. Faulty rear axle bearing holder
4. Faulty tire
5. Axle not tightened properly

Poor brake performance

1. Improper brake adjustment
2. Worn brake shoes
3. Brake linings oily, greasy or dirty
4. Worn brake cam
5. Worn brake drum
6. Brake arm serrations improperly engaged
7. Brake shoes worn at cam contact area

REAR WHEEL

RIM ROUNUT INSPECTION

Measure the rear wheel rim runout.

SERVICE LIMIT: 4.0 mm (0.16 in)

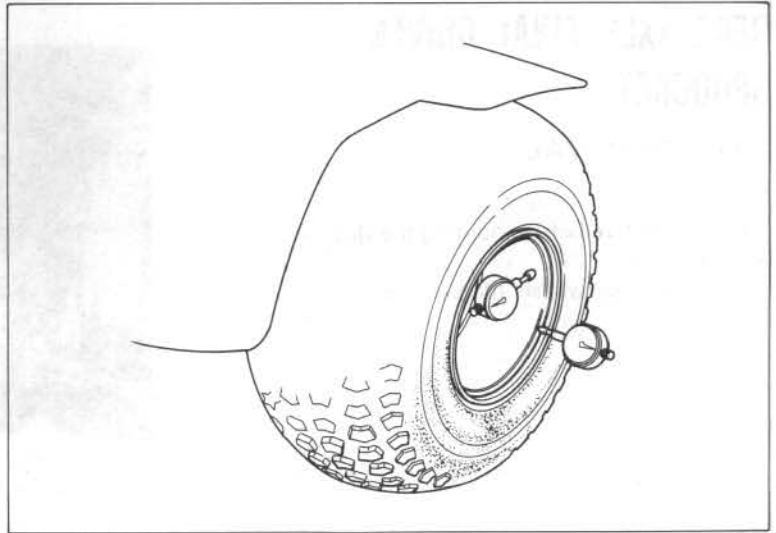

REMOVAL

Raise the rear wheels off the ground with a jack or block under the engine.

Remove the rear wheel hub nuts and the rear wheels.

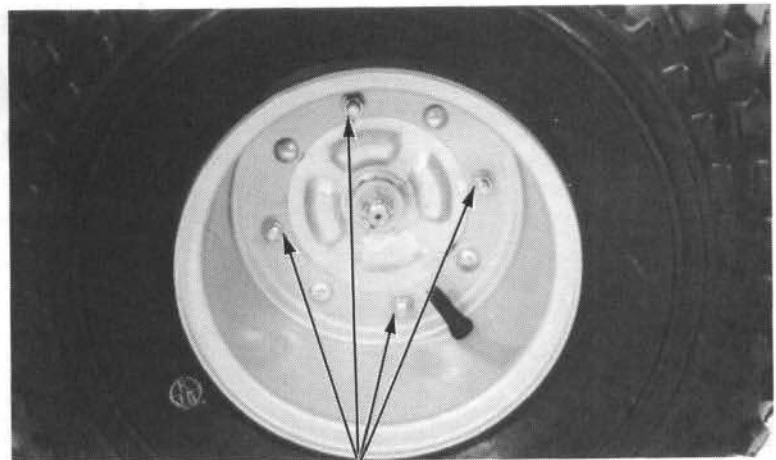

REAR WHEEL HUB NUTS

19–25 N·m
(1.9–2.5 kg·m,
14–18 ft·lb)

REAR TIRE DISASSEMBLY/ ASSEMBLY

For tire disassembly, assembly and repair, refer to pages 12–8 to 12–10.

NOTE

The rear tire has one rim plate located on the inside rim.

INSTALLATION

Install the rear wheel with the tire valve facing out.

Tighten the hub nuts.

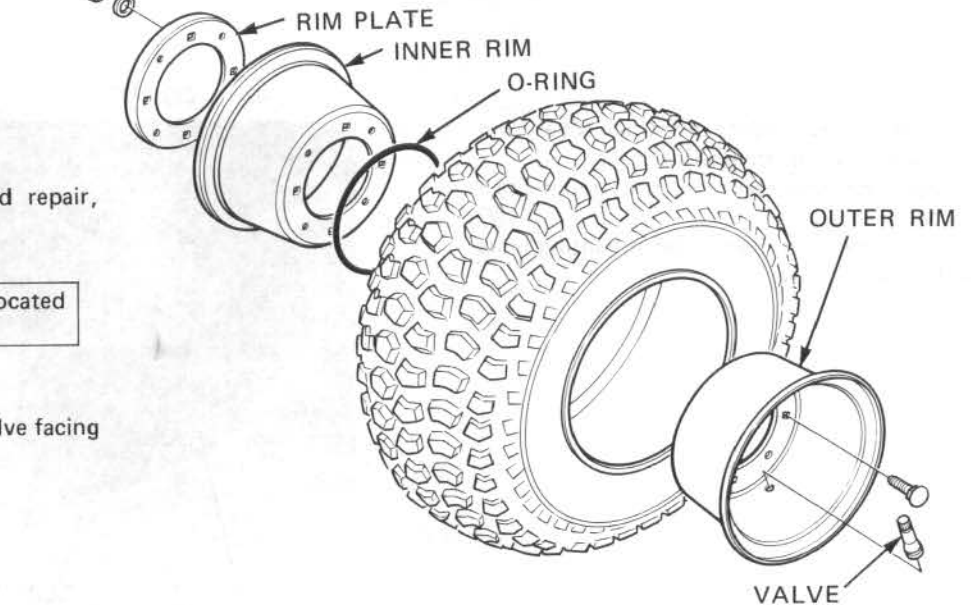

REAR AXLE/FINAL DRIVEN SPROCKET

AXLE REMOVAL

Remove the rear fender.
Remove the five bolts mounting the skid plate and the plate.
Remove the rear wheels (Page 13-3).

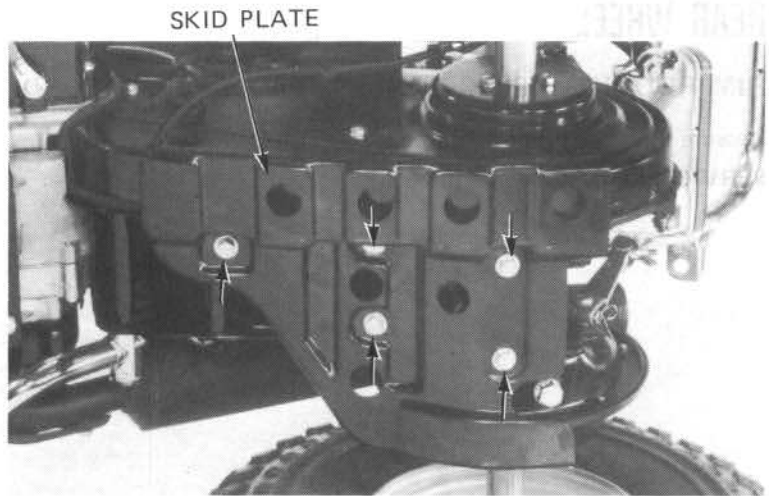

Remove the cotter pins and axle nuts.
Remove the lock washers and rear wheel hubs.

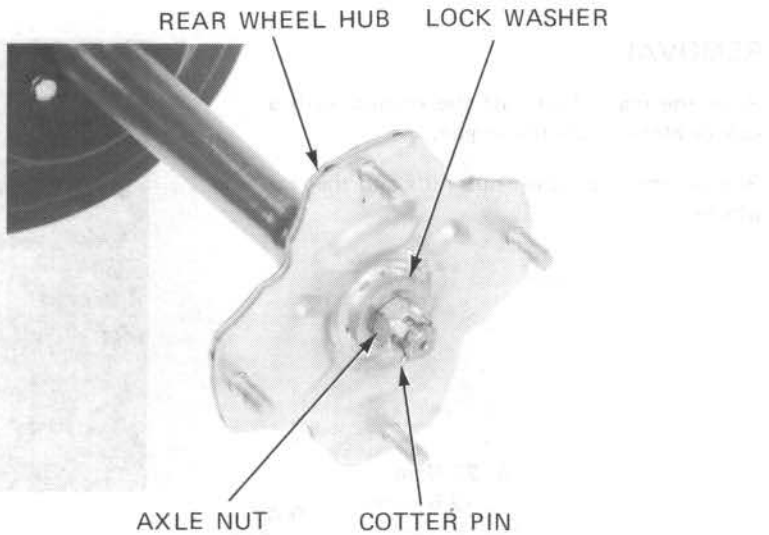

Remove the carburetor overflow tube from the clamps on the drive chain cover.
Remove the three seal cover bolts and the seal cover.
Remove the four chain cover mounting bolts and the chain cover.

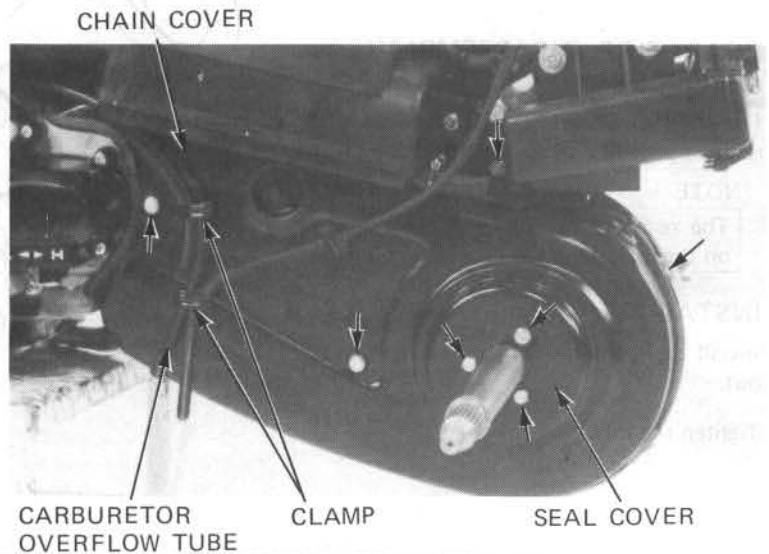

Loosen the rear brake adjusting nut.
Loosen the drive chain adjusting nut and bearing holder mounting bolts.

REAR BRAKE ADJUSTING NUT

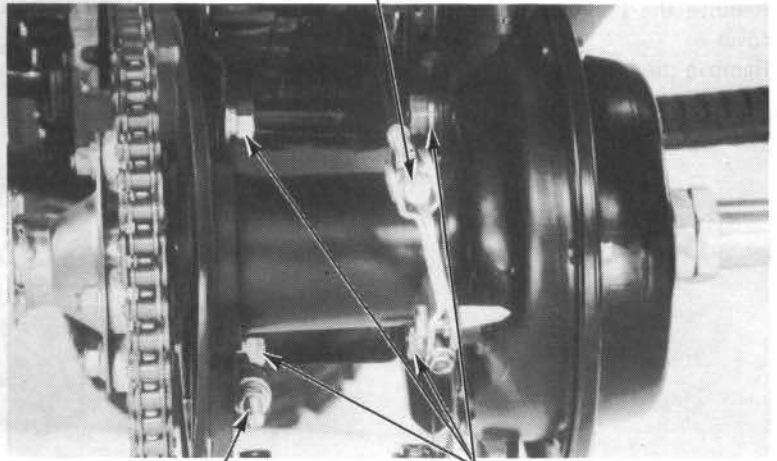

DRIVE CHAIN ADJUSTING NUT BEARING HOLDER BOLTS

Remove the chain clip, master link and drive chain.

CHAIN CLIP

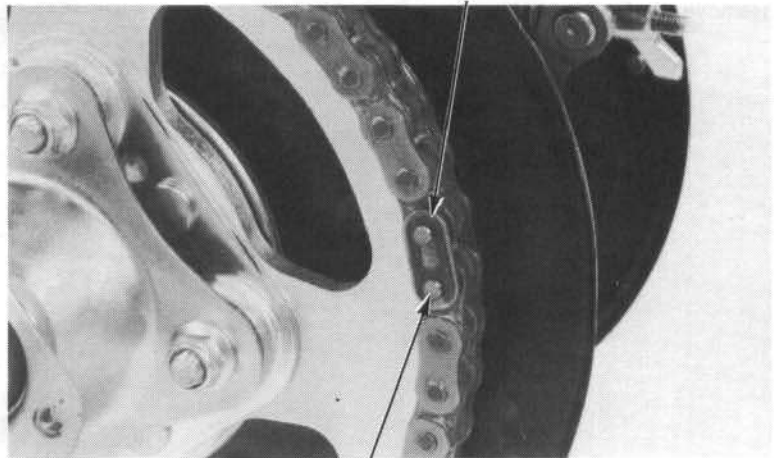

MASTER LINK

Remove the brake drum nuts using the special tools.

In U.S.A. use these tools :
Axle nut torque wrench adapter
07916-958010A
Axle nut holder wrench
07916-958020A

OPEN END WRENCH, 41mm 07916-9580200 } Not available
LOCK NUT WRENCH, 41mm 07916-9580300 } in U.S.A.

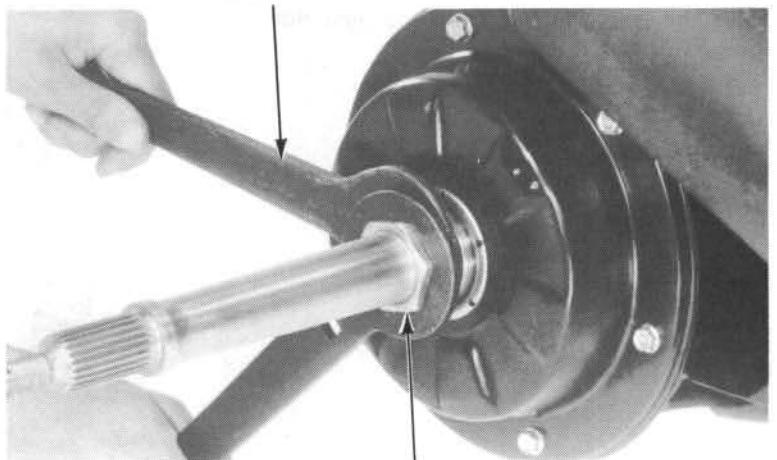

BRAKE DRUM NUT

REAR WHEEL/BRAKE/DRIVE MECHANISM

Remove the brake drum cover bolts and the cover.
Remove the brake drum.

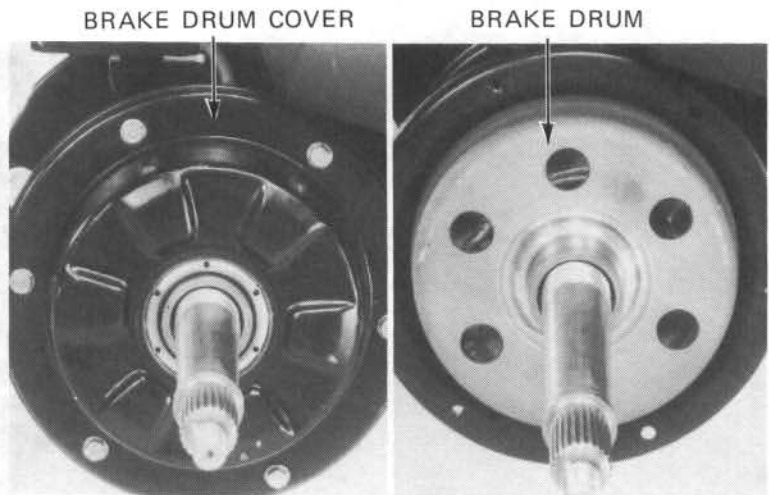

Remove the O-ring.

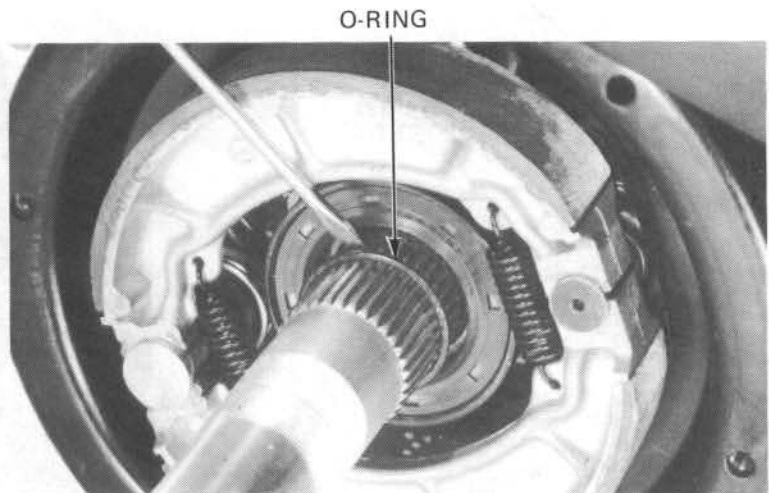

Drive the rear axle out from the right side using a soft hammer.

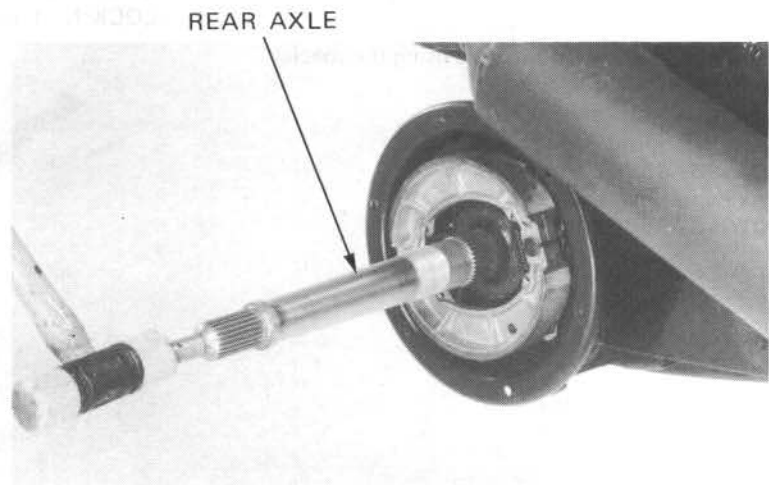

AXLE DISASSEMBLY

Remove the four damper cover nuts and the damper cover.

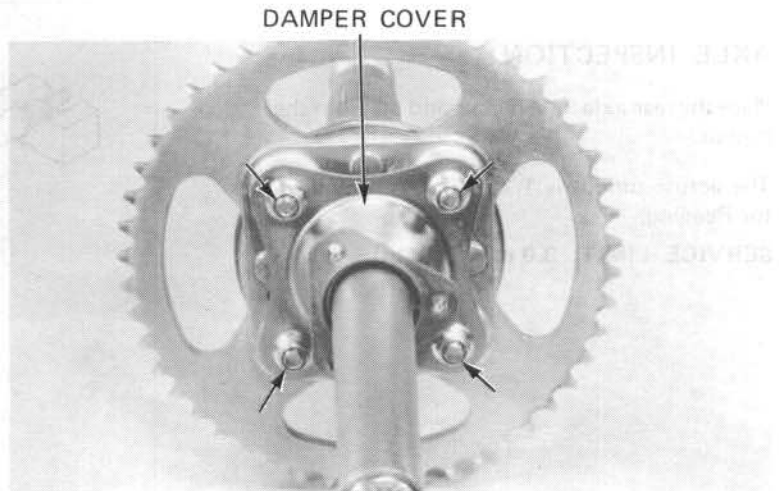

Remove the O-ring from the rear axle.

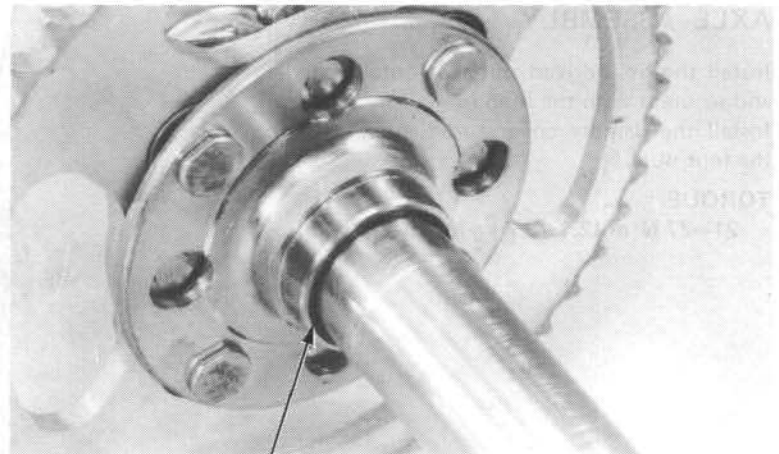

Remove the snap ring securing the final driven sprocket and the sprocket from the axle.

FINAL DRIVEN SPROCKET INSPECTION

Check the damper rubbers for damage. Replace if necessary.

Check the condition of the final driven sprocket teeth.

Replace the sprocket if it is worn or damaged.

NOTE

- If the driven sprocket is worn or damaged, the drive chain and the drive sprocket must be inspected.
- Never install a new drive chain on a worn sprocket or a worn chain on new sprockets. Both chain and sprocket must be in good condition or the replacement chain or sprockets will wear rapidly.

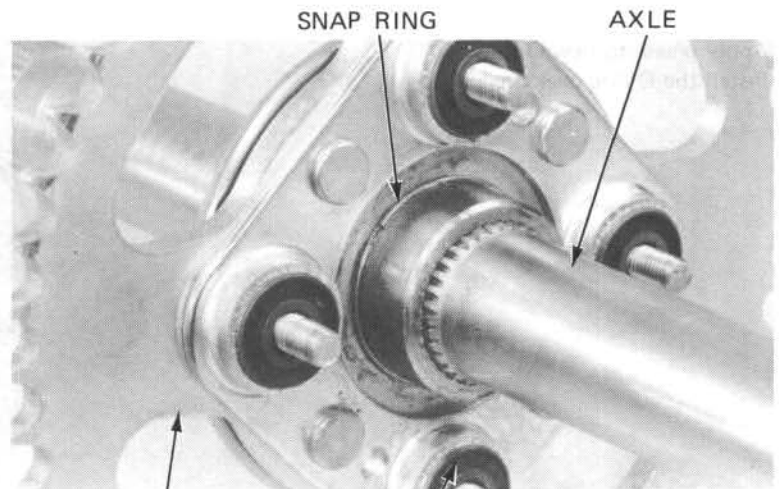

FINAL DRIVEN SPROCKET DAMPER RUBBER

AXLE INSPECTION

Place the rear axle in V-blocks and measure the runout.

The actual runout is 1/2 of the Total Indicator Reading.

SERVICE LIMIT: 3.0 mm (0.12 in)

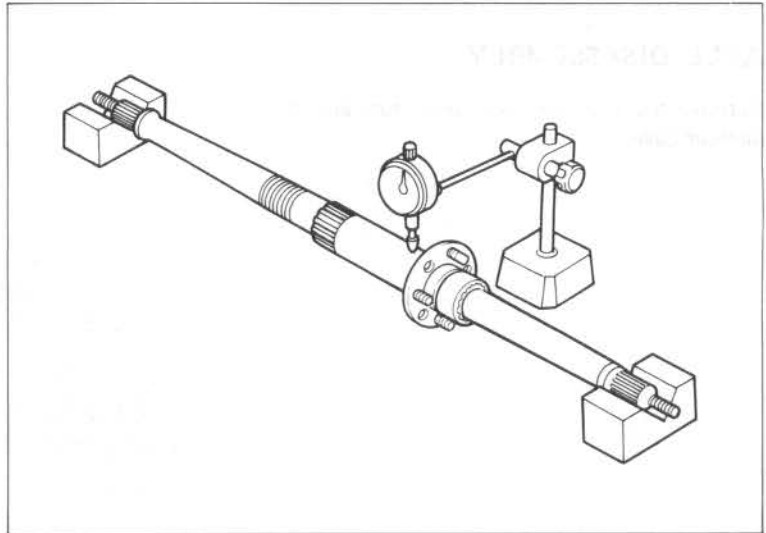

AXLE ASSEMBLY

Install the final driven sprocket onto the axle and secure it with the snap ring. Install the damper cover and tighten it with the four nuts.

TORQUE:

21–27 N·m (2.1–2.7 kg·m, 15–20 ft·lb)

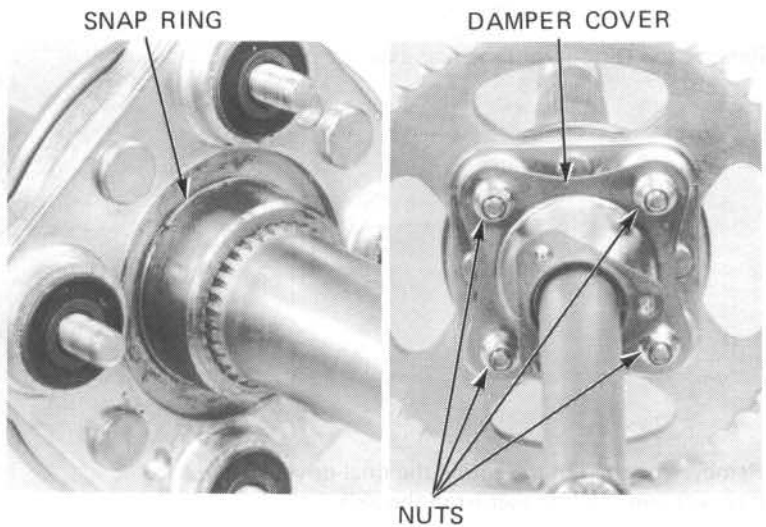

Apply grease to new O-ring. Install the O-ring over the axle.

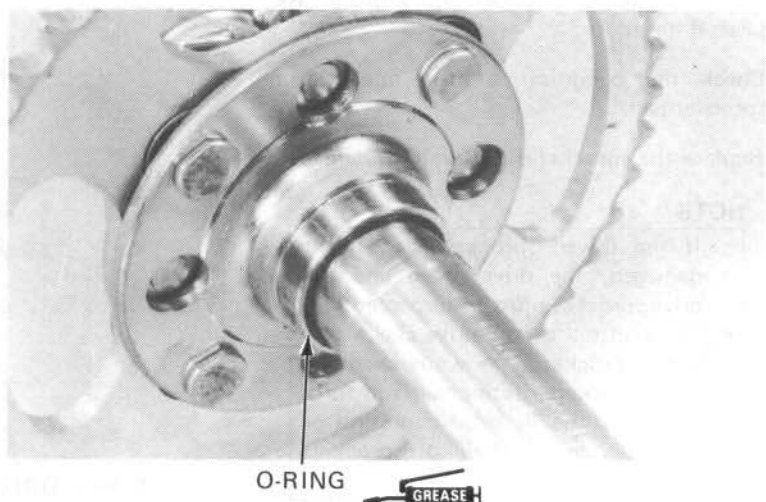

AXLE INSTALLATION

Insert the axle into the bearing holder from the left side.
Apply grease to the new O-ring.
Install the O-ring over the axle.

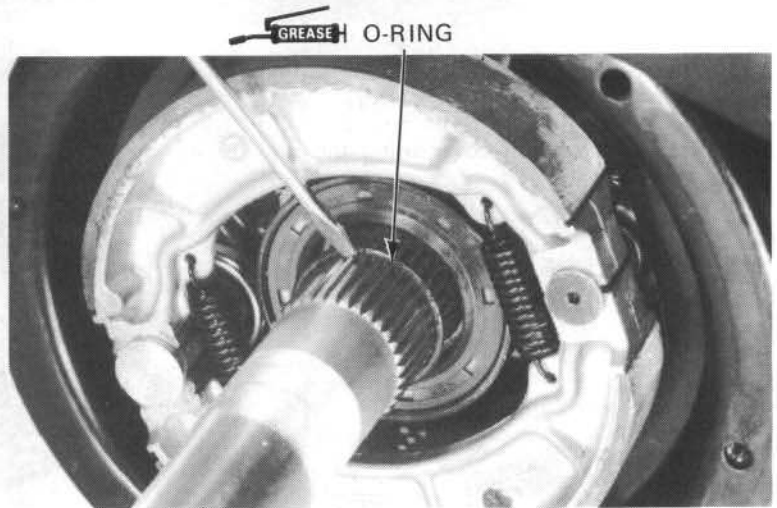

Install the brake drum.

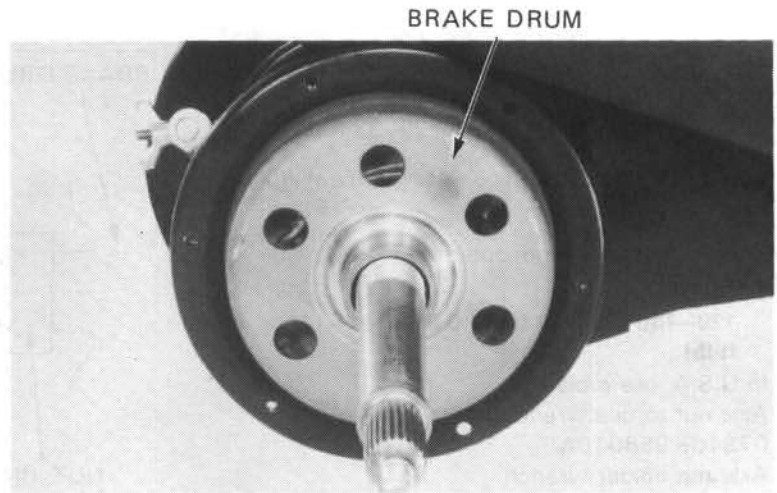

Make sure that the dust seal on the brake drum cover is in good condition.
Replace the dust seal with a new one, if necessary.
Apply grease to the lip of the dust seal.



REAR WHEEL/BRAKE/DRIVE MECHANISM

Install the rubber seal onto the brake drum cover.

Install the brake drum cover using the six bolts.

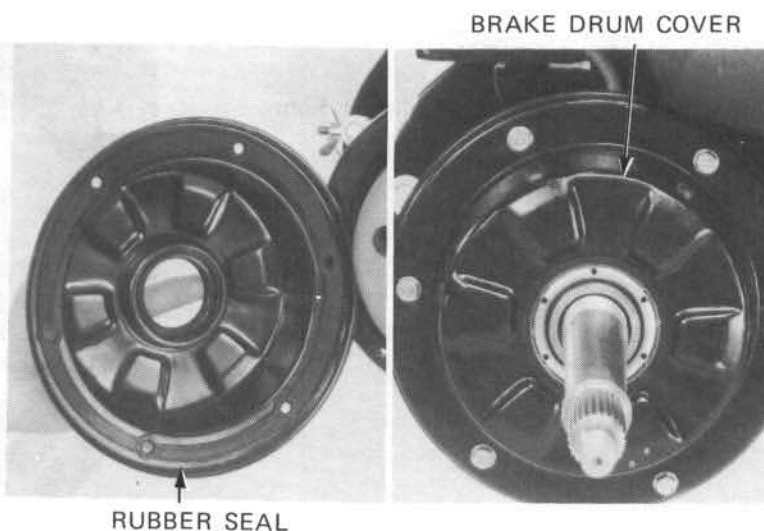

OPEN END WRENCH, 41mm 07916-9580200
LOCK NUT WRENCH, 41mm 07916-9580300
Not available in U.S.A.

Tighten the brake drum inner nut.

TORQUE:

35-45 N·m (3.5-4.5 kg-m, 25-33 ft-lb)

Apply LOCKTITE® or equivalent to the shaft threads.

Tighten the brake drum outer nut.

TORQUE:

120-140 N·m (12.0-14.0 kg-m, 87-101 ft-lb)

In U.S.A. use tools :

Axle nut torque wrench adapter

07916-958010A

Axle nut holder wrench

07916-958020A

NOTE

Wipe grease off the shaft before applying LOCKTITE® or equivalent.

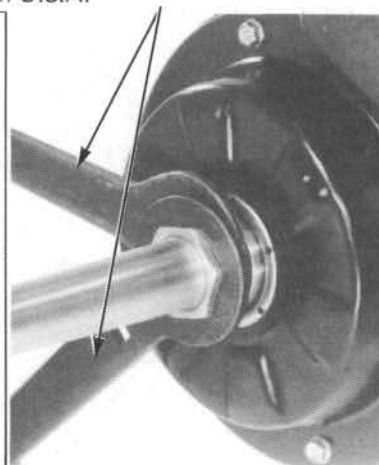
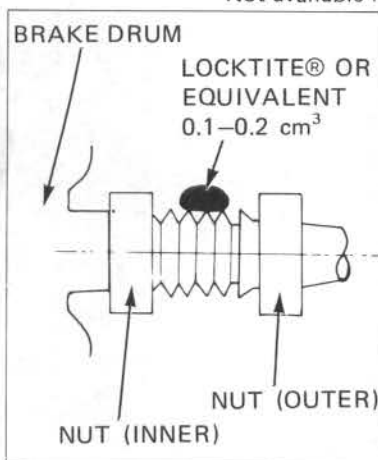

Install and connect the drive chain with the master link and 4 O-rings.

Install the master link clip in the direction shown.

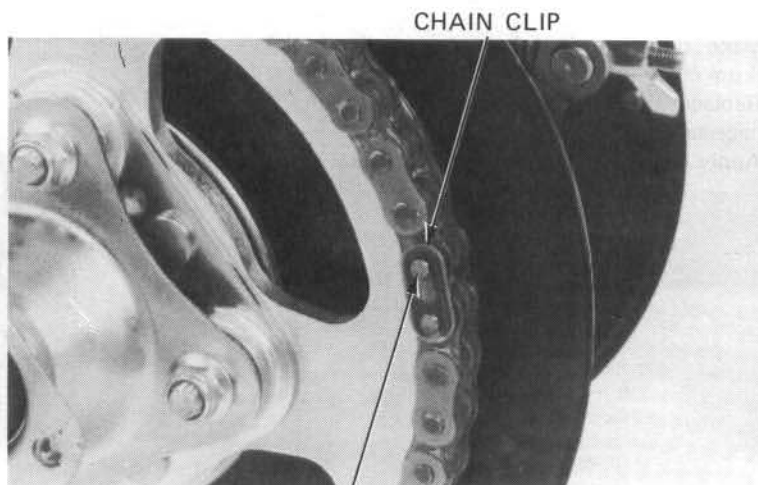

Adjust the drive chain and tighten the bearing holder mounting bolts.

BEARING HOLDER MOUNTING BOLTS

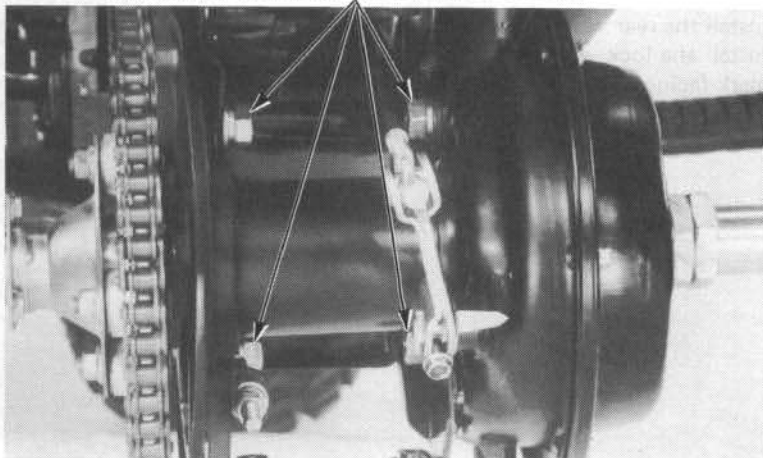

Install the rubber seal onto the drive chain cover.

Install the drive chain cover using the four bolts.

Install the seal plate using the three bolts.

Clamp the carburetor overflow tube with the clamps.

RUBBER SEAL

BOLTS

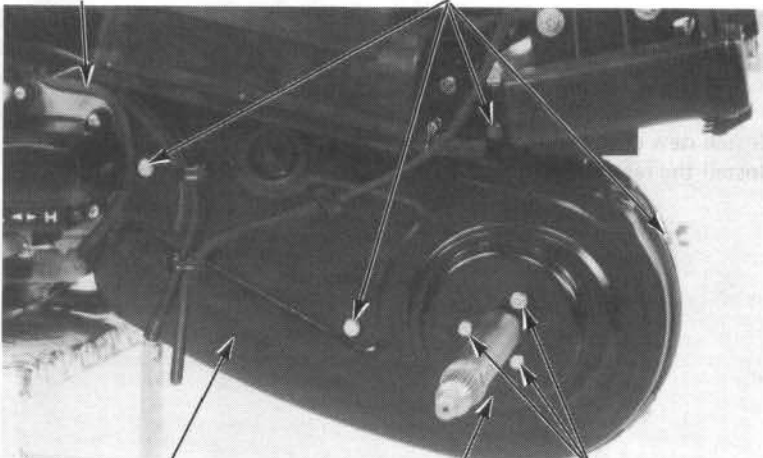

DRIVE CHAIN COVER

SEAL PLATE

BOLTS

Apply grease to the splines on both ends of the axle.

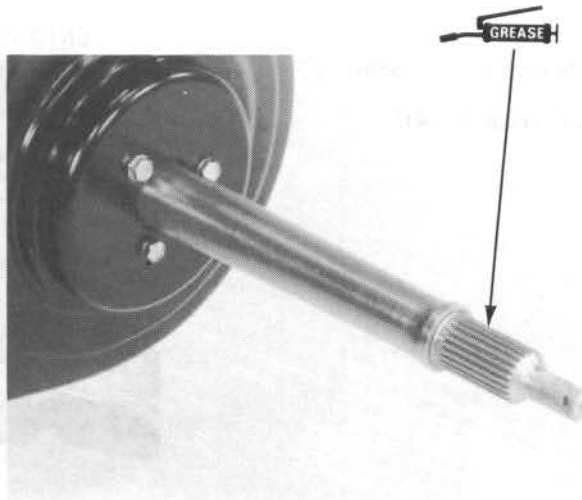

REAR WHEEL/BRAKE/DRIVE MECHANISM

Install the rear wheel hubs over the axle.
Install the lock washers with the "OUTSIDE"
mark facing out.

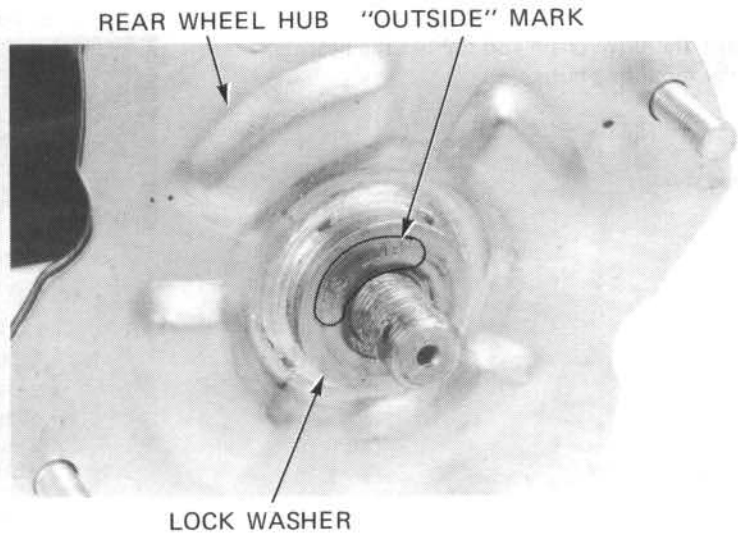

Tighten the rear axle nuts.

TORQUE:

60–80 N·m (6.0–8.0 kg-m, 43–58 ft-lb)

Install new cotter pins and bend the ends.
Install the rear wheels (Page 13–3).

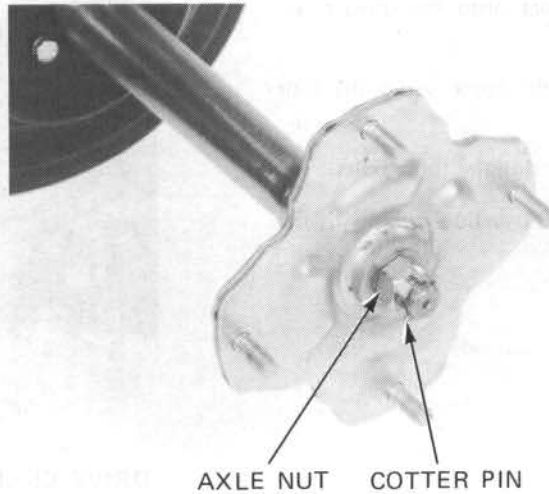

Install the skid plate with the five bolts.

Adjust the rear brake (Page 3–14).

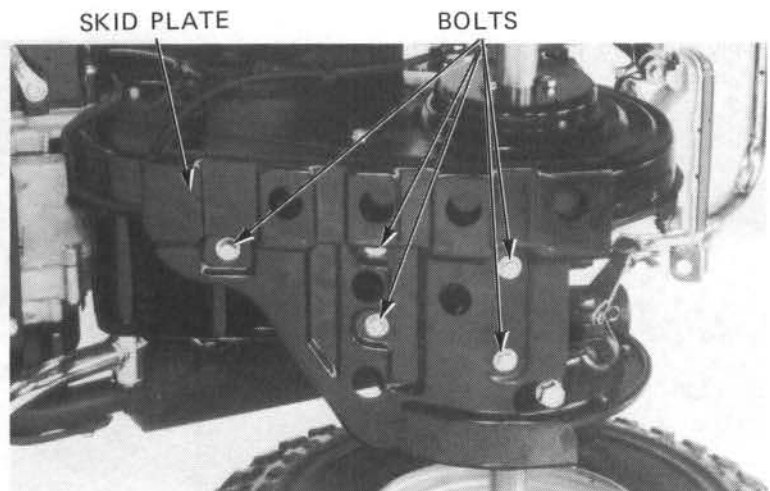

REAR BRAKE

Remove the right rear wheel (Page 13-3).
Remove the brake drum nuts, brake drum cover and drum (Page 13-5 and 13-6).

BRAKE LINING INSPECTION

Measure the brake lining thickness.

SERVICE LIMIT: 2 mm (0.1 in)

Replace the brake lining if it is thinner than the service limit.

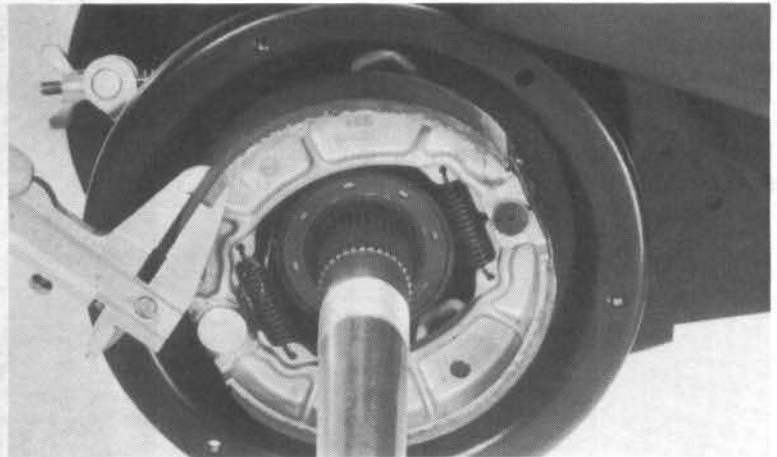

BRAKE DRUM INSPECTION

Measure the brake drum I.D.

SERVICE LIMIT: 141 mm (5.6 in)

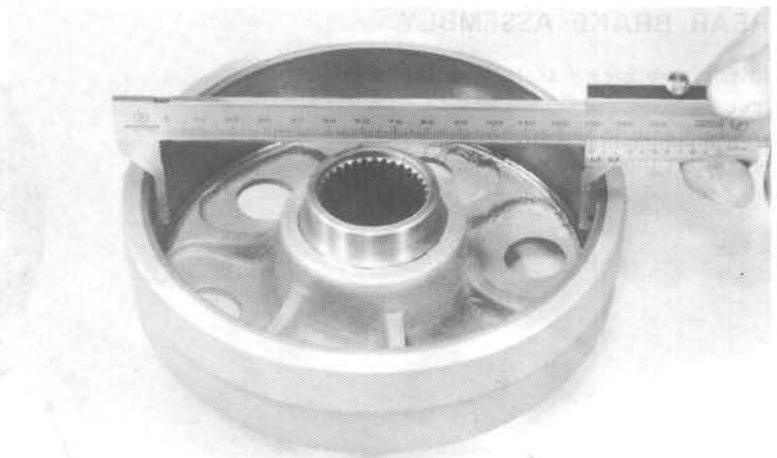

BRAKE DISASSEMBLY

Expand and remove the brake shoes by hand.

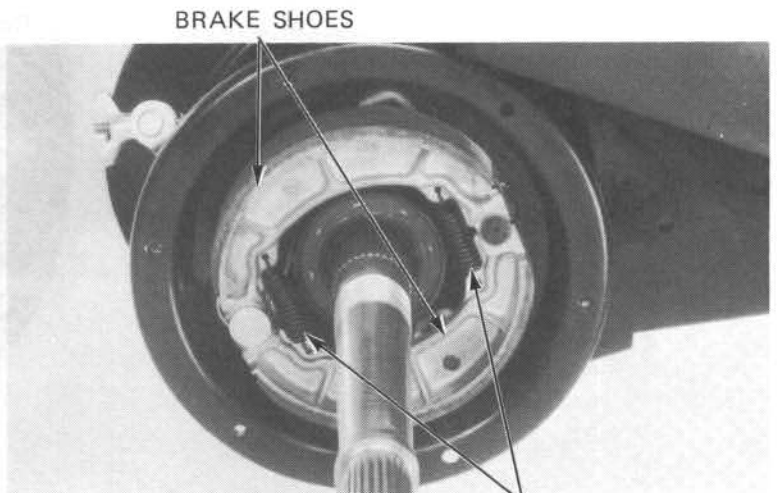

BRAKE SHOES

SHOE SPRINGS

REAR WHEEL/BRAKE/DRIVE MECHANISM

Remove the rear brake adjusting nut and disconnect the brake rod from the brake arm. Remove the brake arm bolt, brake arm and indicator plate.

Remove the brake cam, return spring, dust seal and rubber seals.

BRAKE ROD ADJUSTING NUT RETURN SPRING

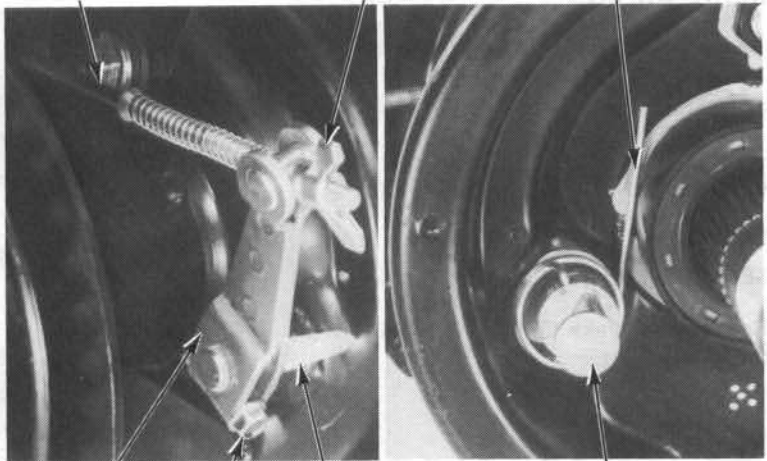

BRAKE ARM BOLT INDICATOR PLATE BRAKE CAM

REAR BRAKE ASSEMBLY

Install new grease seals into the brake cam hole.

Apply grease to the anchor pin and brake cam and insert the brake cam into the hole.

GREASE SEAL ANCHOR PIN

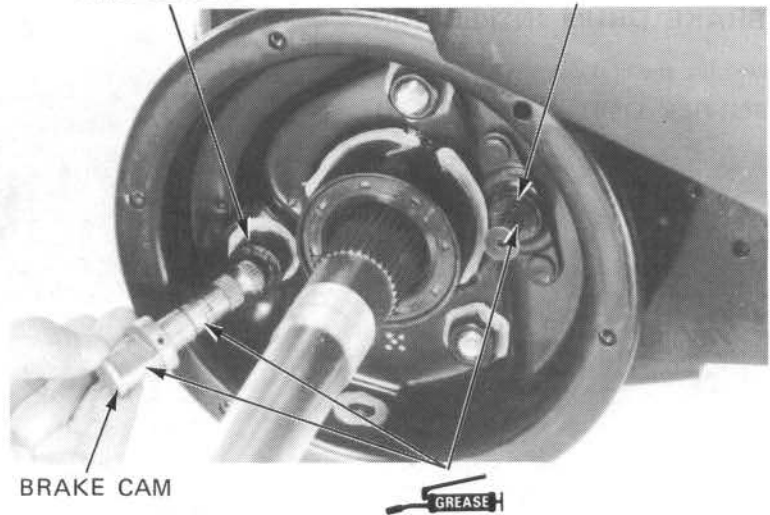

BRAKE CAM

GREASE

RETURN SPRING

Install the return spring as shown.

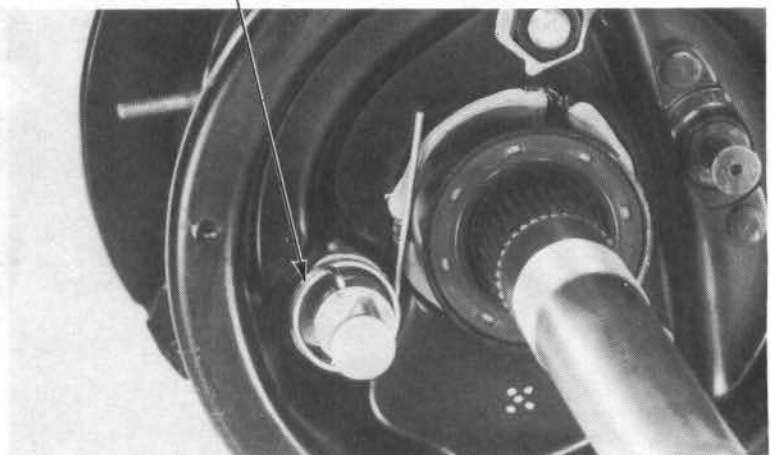

- Install the dust seal.
- Align the tab on the indicator plate with the punch mark on the brake cam and install the indicator plate.
- Install the brake arm over the brake cam aligning the punch marks.
- Install the brake arm bolt and nut and tighten the bolt.

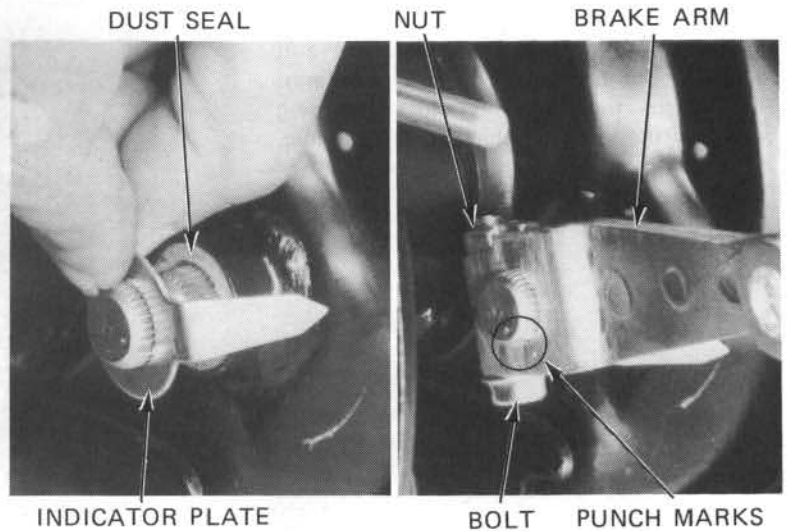

Install the brake shoes and springs.

WARNING

- Contaminated brake linings reduce stopping power.
- Keep grease off the linings. Wipe excess grease off the cam.

Install the brake drum, drum cover and drum nuts (Pages 13-9 and 13-10).

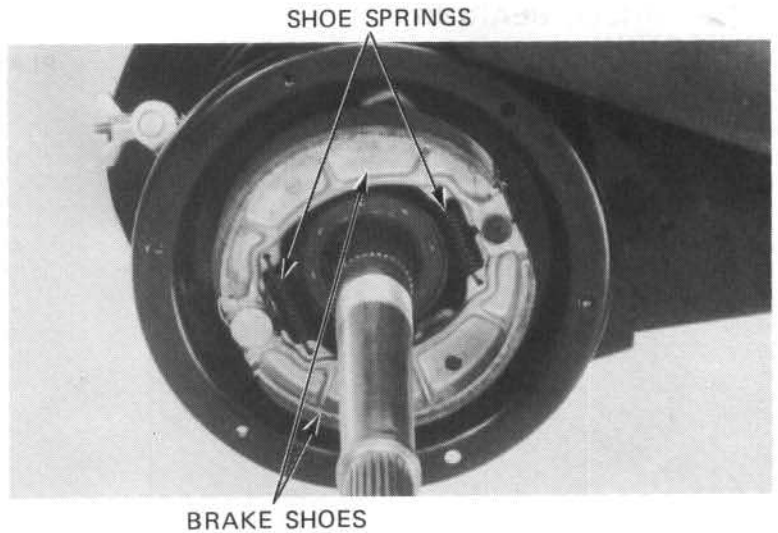

REAR AXLE BEARING HOLDER

REMOVAL

- Remove the following:
- rear wheel (Page 13-3).
 - drive chain and rear axle (Page 13-4).
 - drive chain rear cover.

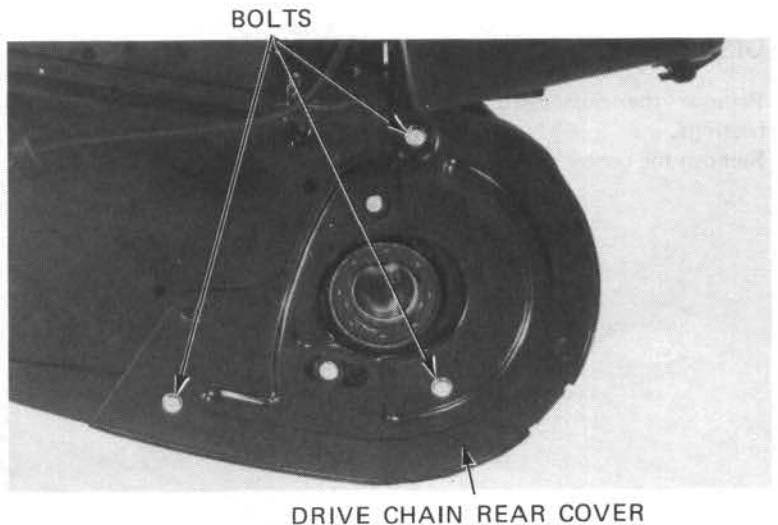

REAR WHEEL/BRAKE/DRIVE MECHANISM

Remove the rear brake adjusting nut and disconnect the brake rod from the brake arm. Remove the four bearing holder mounting bolts and the bearing holder from the frame.

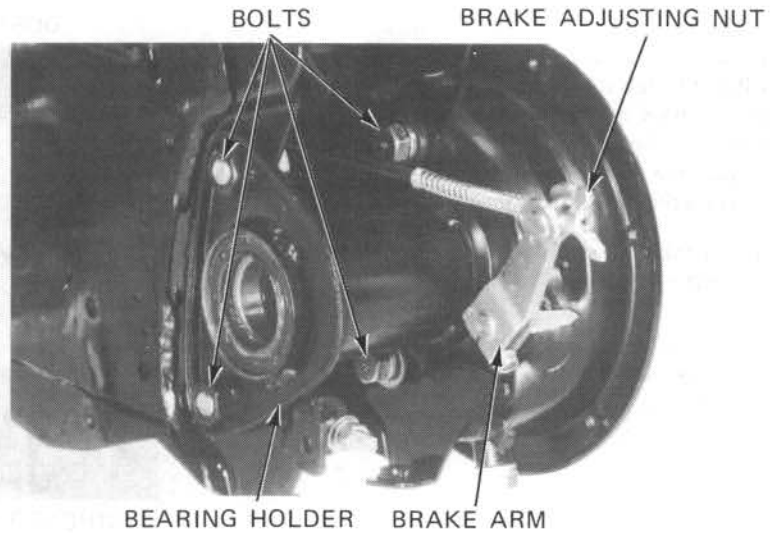

REAR WHEEL BEARING INSPECTION

Check the rear wheel bearings. Replace the bearings if they are noisy or have excessive play.

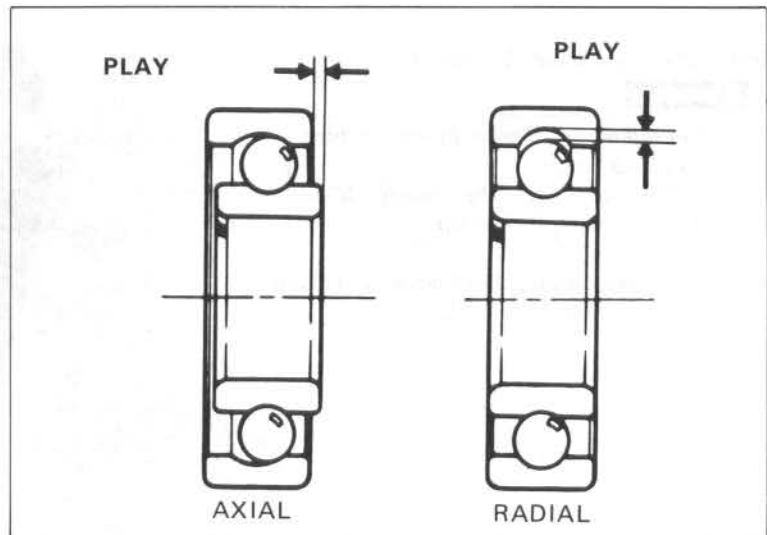

DISASSEMBLY

Remove the dust seals and drive out the bearings.
Remove the center collar.

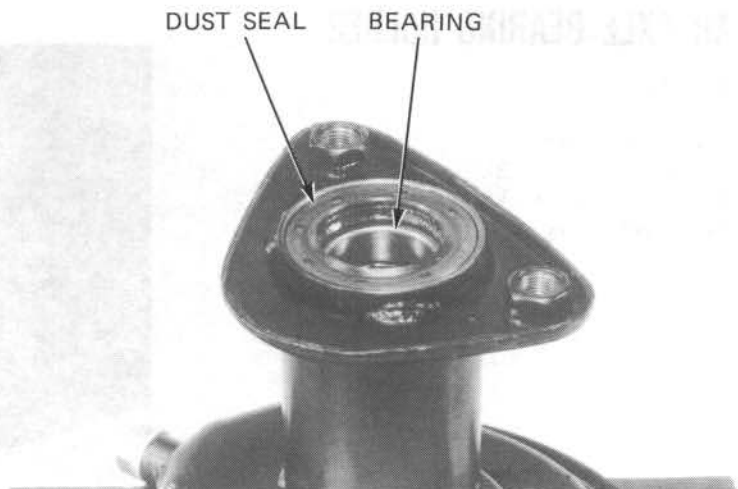

ASSEMBLY

Pack the bearing cavities with grease.
Drive the right bearing squarely into the bearing holder until it seats.

Install the center collar and drive the left bearing in squarely until it seats.

NOTE

Install the bearings with marks facing out.

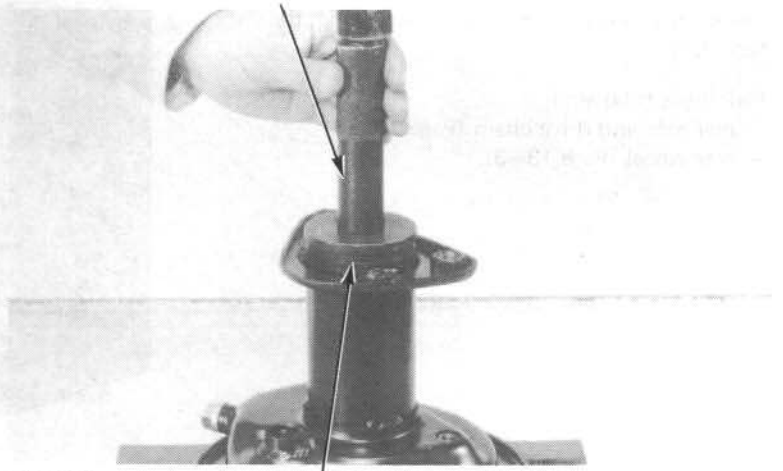

DRIVER	07749-0010000	} or DRIVER
ATTACHMENT, 62 x 68 mm	07746-0010500	
PILOT, 35 mm	07746-0040800	

Coat the dust seal lips with grease and install the dust seals.



DUST SEAL

INSTALLATION

Install the bearing holder and drive chain adjuster with the four mounting bolts.

NOTE

Do not tighten the bolts before adjusting the drive chain.

Connect the brake rod to the brake arm and install the brake adjusting nut.

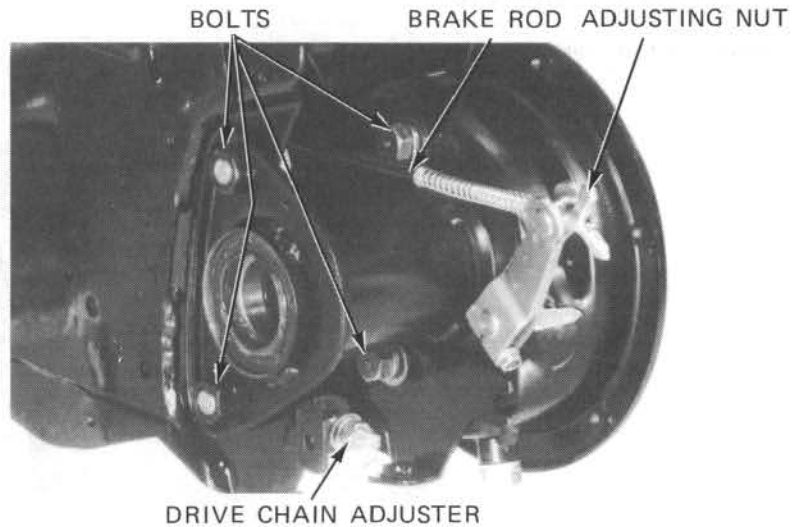

REAR WHEEL/BRAKE/DRIVE MECHANISM

Install the drive chain rear cover using the three bolts.

Install the following:

- rear axle and drive chain (Page 13–9).
- rear wheel (Page 13–3).

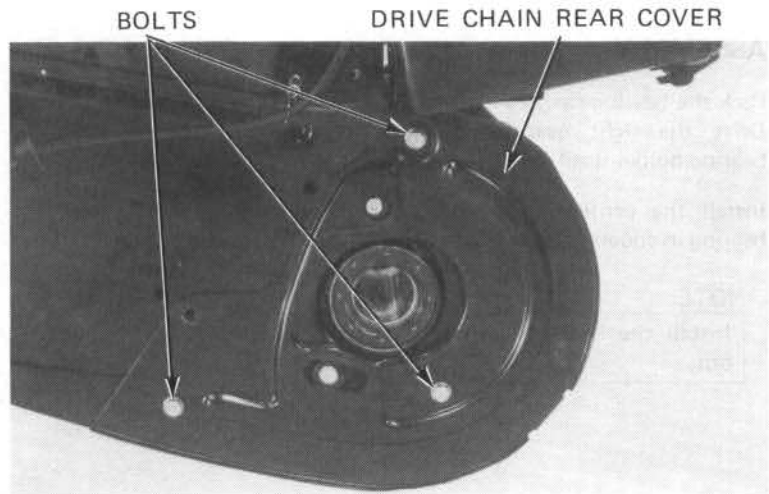

BRAKE PEDAL

REMOVAL

Remove the seat and rear fender.
Remove the rear brake adjusting nut.
Loosen the brake cable lock nut and adjusting nut.
Remove the brake pedal return spring.
Remove the cotter pin, washer and rear brake pedal and disconnect the brake cable from the pedal linkage.

INSTALLATION

Install the brake pedal in the reverse order of removal.

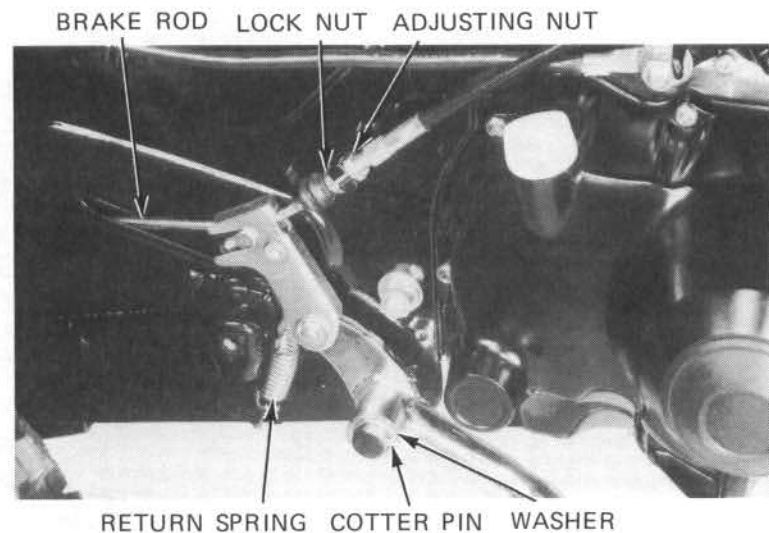

NOTE

Apply grease to the brake pedal pivot shaft, link pin and cable end.

Adjust the rear brake (Page 3–14).

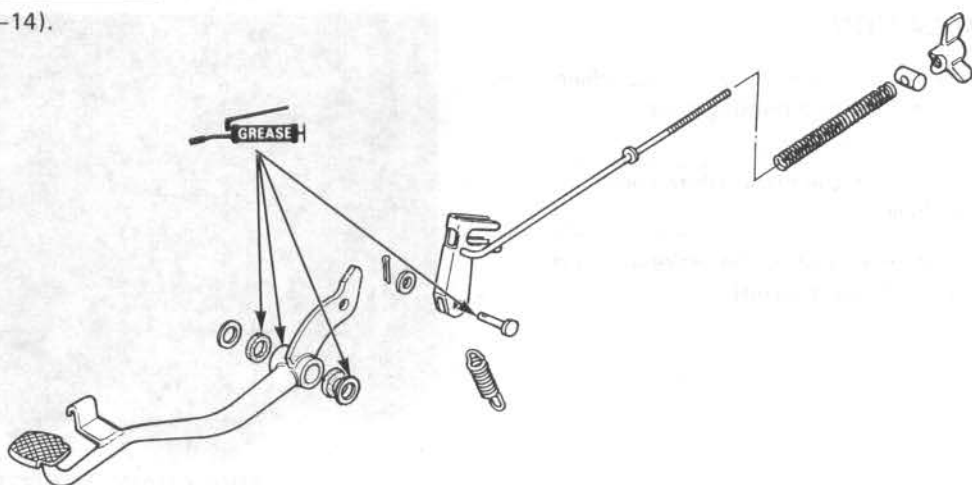

14. REAR FENDER/ EXHAUST PIPE

REAR FENDER

14-1

EXHAUST PIPE

14-2

REAR FENDER

Remove and disassemble the rear fender.

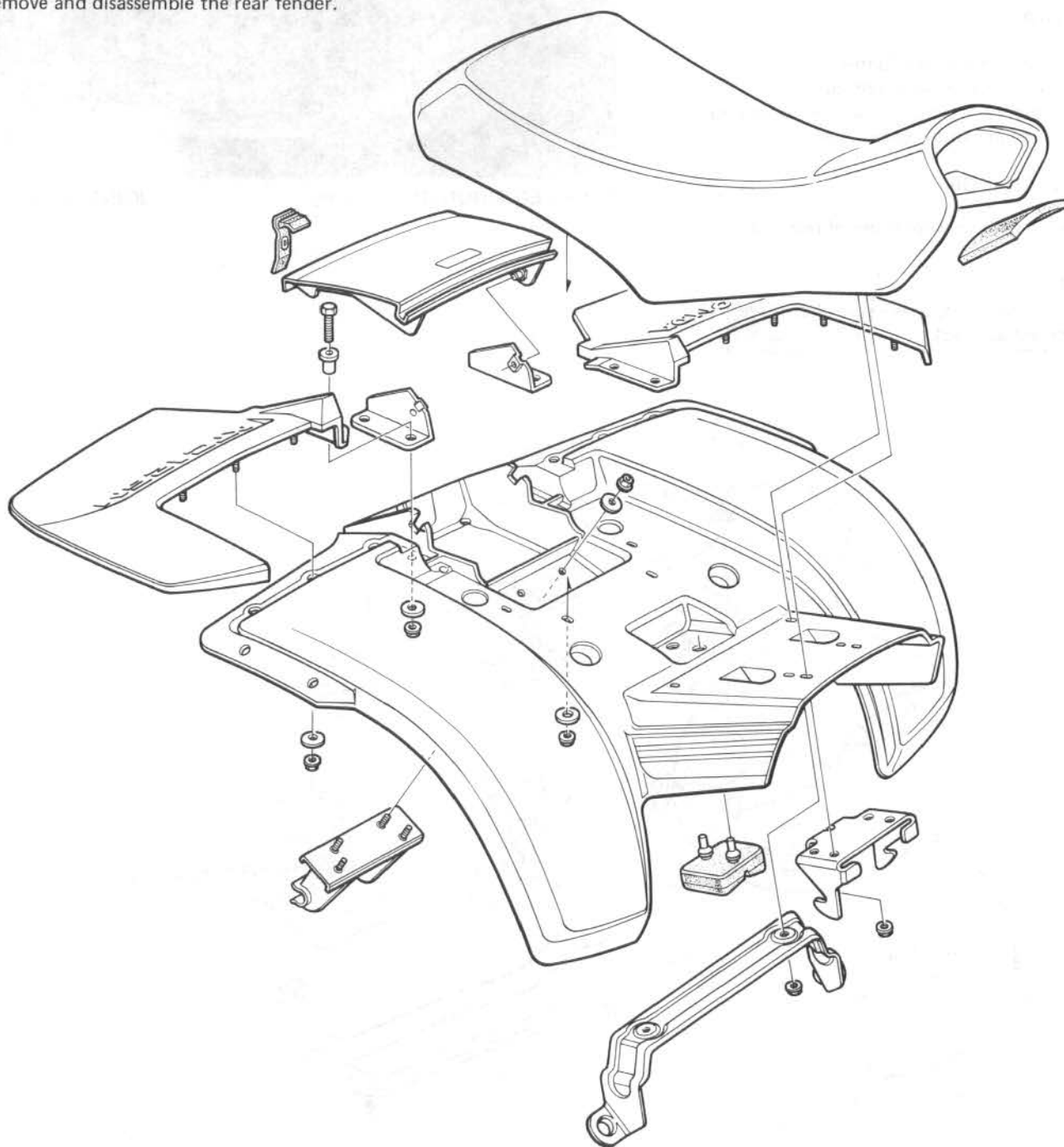

EXHAUST PIPE

Refer to Page 3-16 for spark arrester cleaning.

WARNING

Do not service the exhaust pipe or muffler while they are hot.

REMOVAL

Remove the seat and rear fender.
Remove the exhaust pipe joint nuts.
Remove the two exhaust muffler mounting bolts and the exhaust pipe assembly.

INSTALLATION

Installation is the reverse order of removal.

NOTE

After installation, make sure that there are no exhaust leaks.

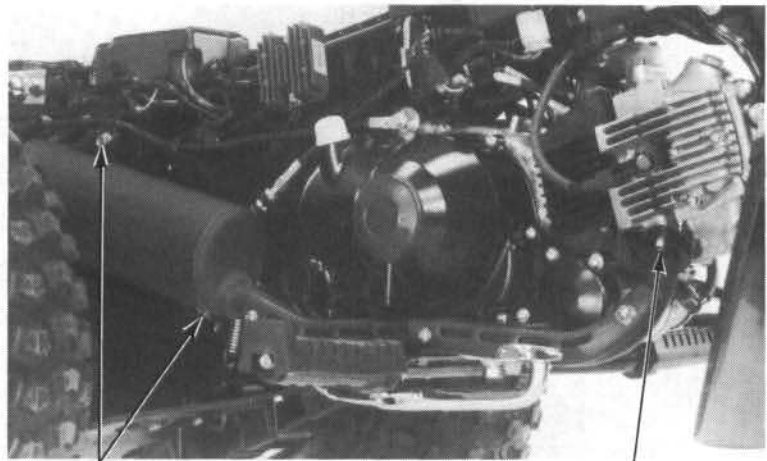

MUFFLER MOUNTING BOLTS

JOINT NUTS

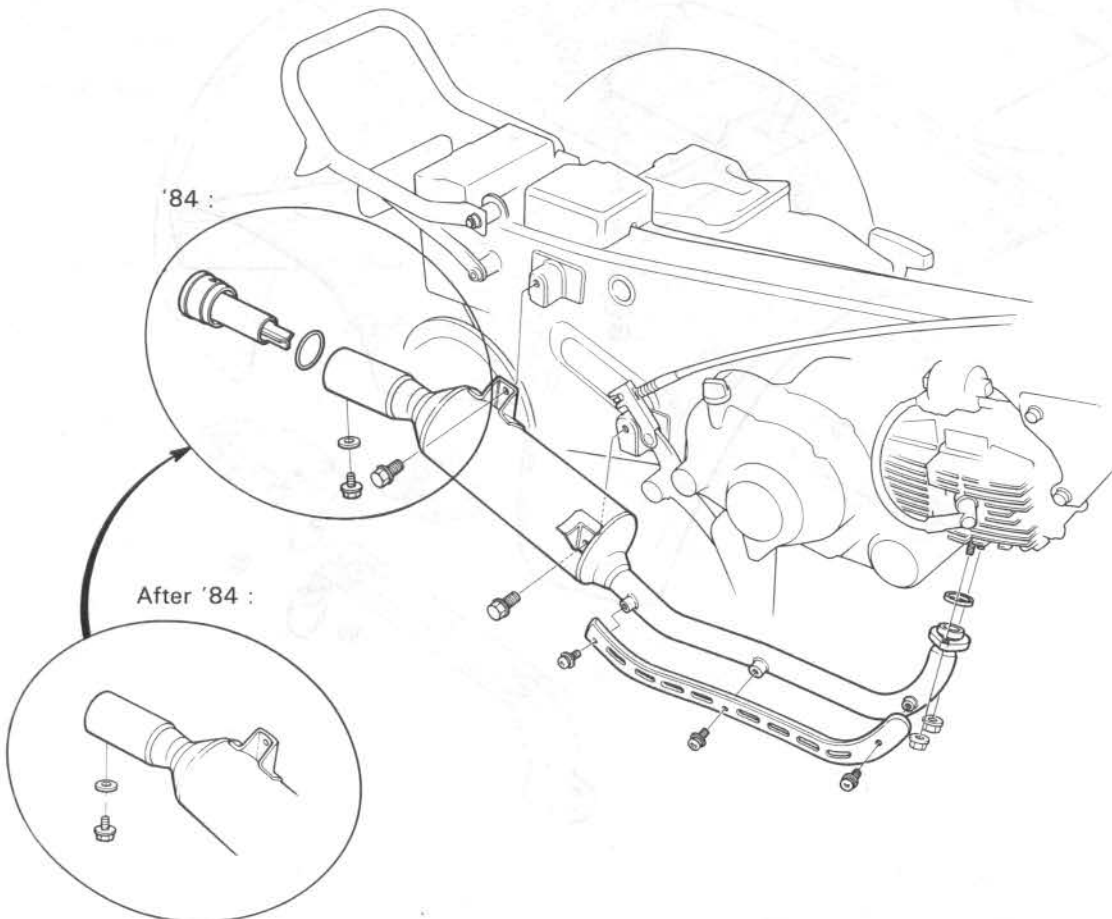

MEMO



IGNITION SYSTEM

After '84

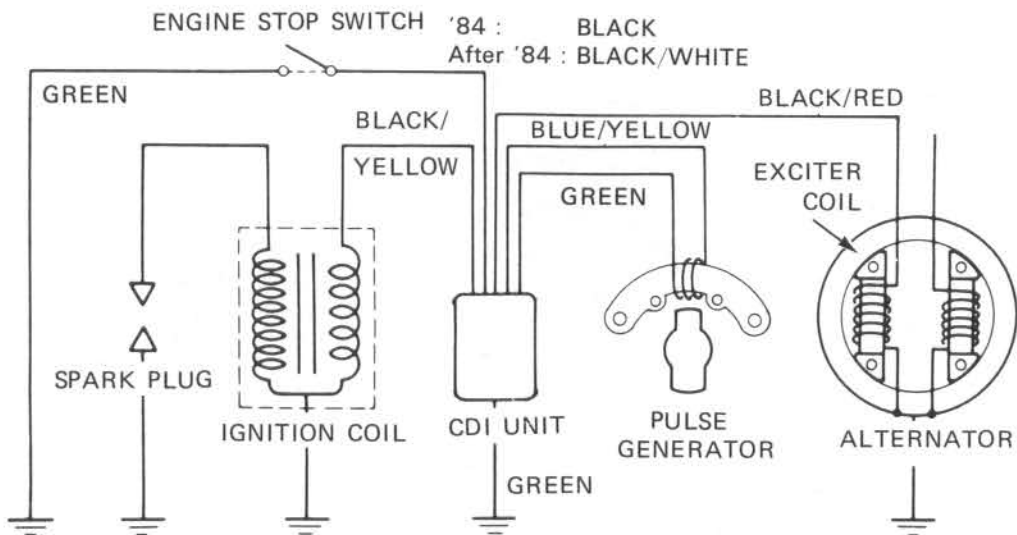
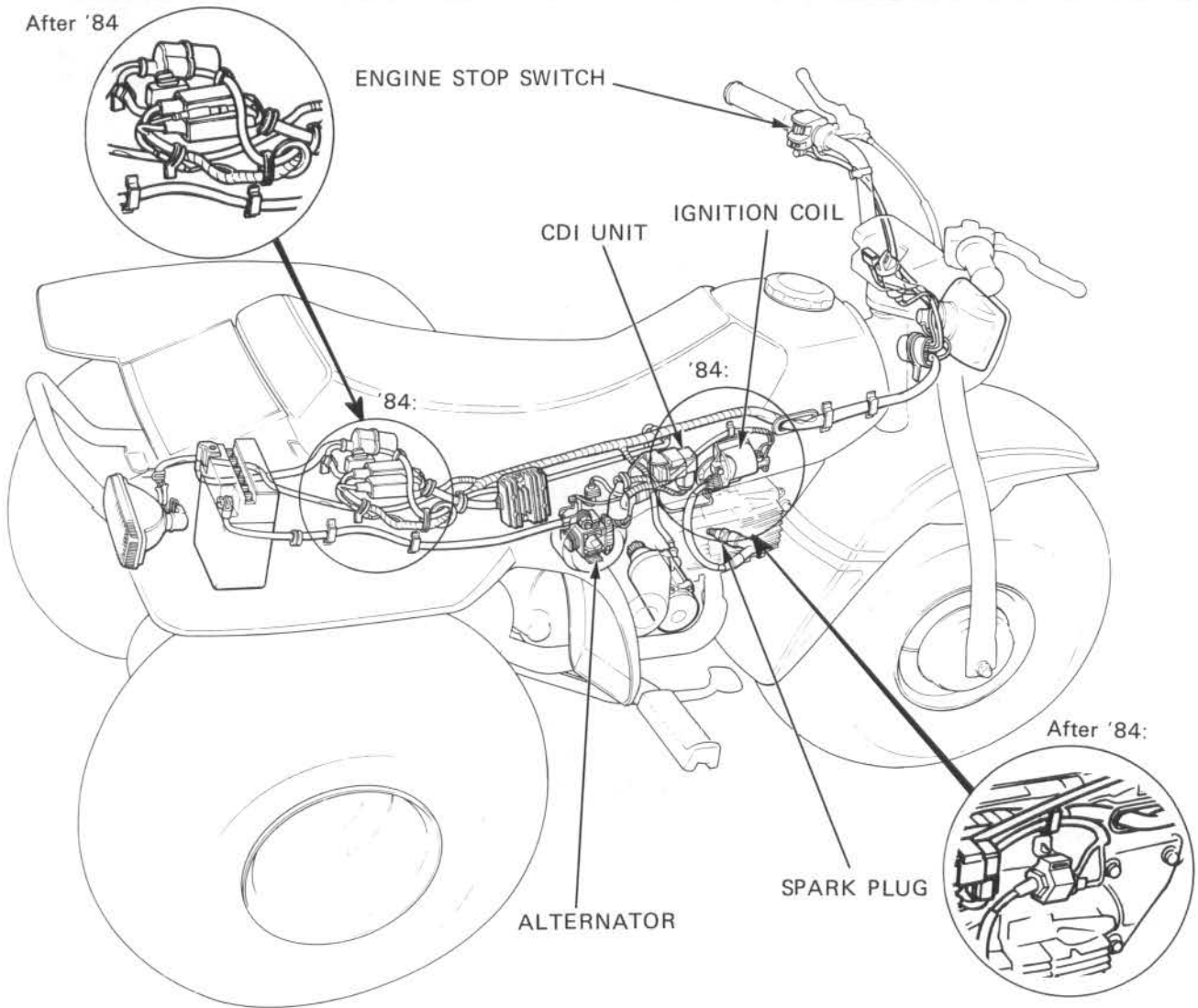

15. IGNITION SYSTEM

SERVICE INFORMATION	15-1
TROUBLESHOOTING	15-1
IGNITION COIL	15-2
ALTERNATOR EXCITER COIL	15-3
CDI UNIT	15-3
PULSE GENERATOR	15-4
IGNITION TIMING	15-5

SERVICE INFORMATION

GENERAL

- Ignition timing does not normally need to be adjusted since the CDI (Capacitive Discharge Ignition) unit is factory pre-set.
- For spark plug inspection, refer to Page 3-5.
- For pulse generator removal, see Section 6.

SPECIFICATIONS

Spark plug	DR8ES-L (NGK) X24ESR-U (ND) RA6YC (CHAMPION)
Spark plug gap	0.6-0.7 mm (0.024-0.028 in)
Ignition timing:	
– Initial	$10^{\circ} \pm 2^{\circ}$ BTDC/1,700 \pm 100 rpm
– Advance start	1,950 \pm 150 rpm
– Full advance	$32^{\circ} \pm 2^{\circ}$ BTDC/3,400 \pm 150 rpm

TOOL

Digital Multi-tester

KS-AHM-32-003 (U.S.A. only) or TH-5H-1 or
07308-0020000

TROUBLESHOOTING

Engine starts but stops

1. No spark at plug
2. Improper ignition timing
3. Faulty spark plug

No spark at plug

1. Engine stop switch "OFF"
2. Poorly connected, broken or shorted wires
 - Between alternator and CDI unit
 - Between CDI unit and engine stop switch
 - Between CDI unit and ignition coil
 - Between ignition coil and spark plug
 - Between pulse generator and CDI unit
3. Faulty ignition coil
4. Faulty CDI unit
5. Faulty pulse generator
6. Faulty alternator

Engine starts but runs poorly

1. Ignition primary circuit
 - Faulty ignition coil
 - Loose or bare wire
 - Faulty alternator
 - Faulty CDI unit
2. Ignition secondary circuit
 - Faulty plug
 - Faulty pulse generator
 - Faulty high tension wire
3. Improper ignition timing
 - Faulty advancer rotor
 - Faulty pulse generator
 - Faulty CDI unit

IGNITION COIL

CONTINUITY TEST

Measure the primary coil resistance.

RESISTANCE: 0.2–0.4 ohms

'84 :

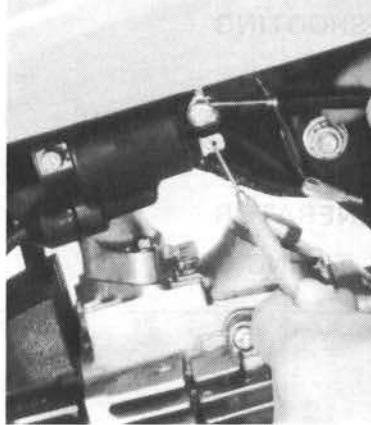

After '84 :

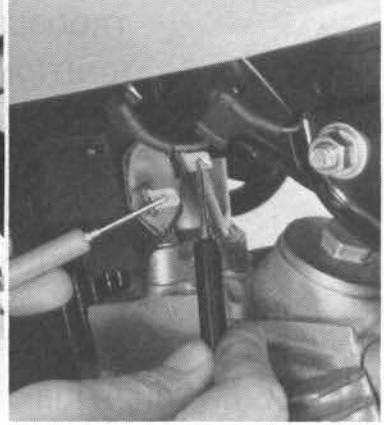

'84 :

Measure the secondary coil resistance with the spark plug cap in place.

RESISTANCE: 10–18 k ohms

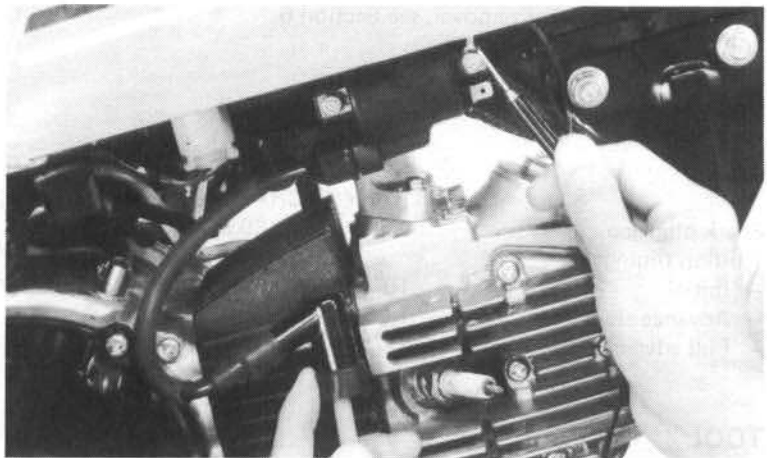

'84 :

Remove the spark wire from the ignition coil and measure the secondary coil resistance.

RESISTANCE : 3.6–4.4 k ohms

After '84 :

Remove the spark plug cap from the wire and measure the Secondary coil resistance.

RESISTANCE : 3.7–4.5 k ohms

After '84 :

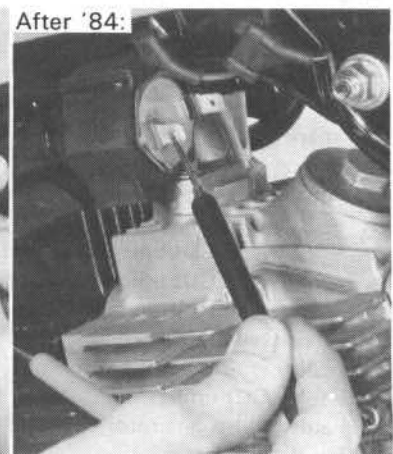
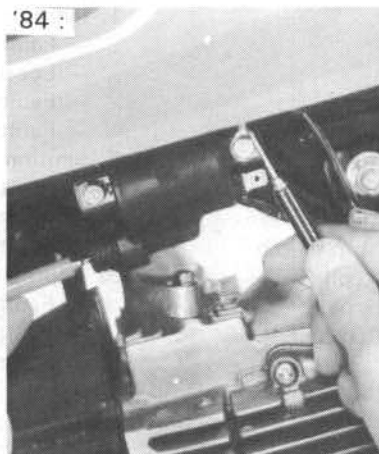

REMOVAL

'84 :

Disconnect the ignition coil wire leads.
Remove the coil by removing the attaching bolts.

After '84 :

Disconnect the ignition coil wire leads.
Remove the ignition coil and attaching bracket.

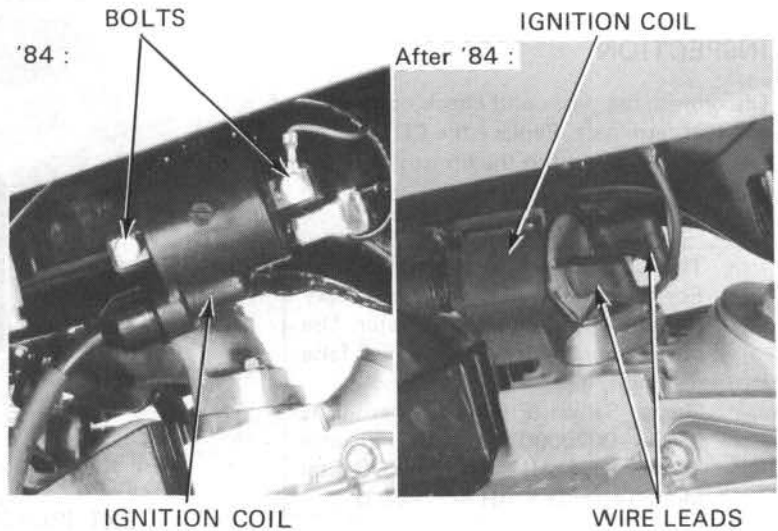

ALTERNATOR EXCITER COIL

Disconnect the alternator black/red wire connector.

Check the resistance between the black/red wire and ground with an ohmmeter.

RESISTANCE: 110 – 400 ohms

Replace the alternator stator if the reading is not within the limit. See Alternator Removal (Page 9-6).

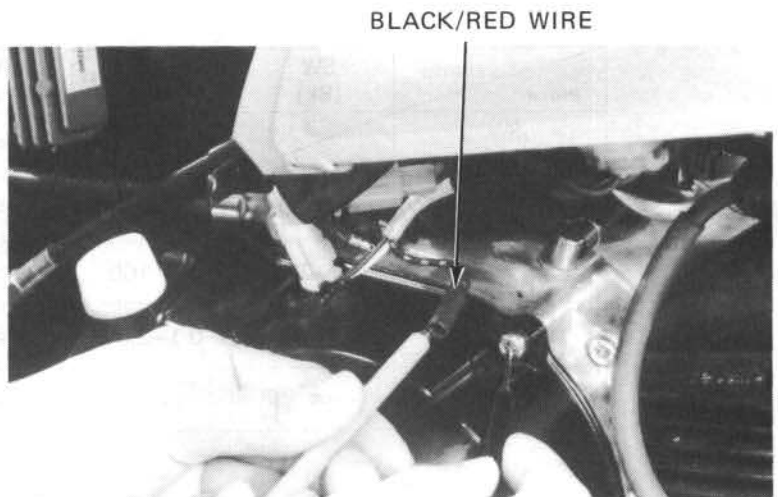

CDI UNIT

REMOVAL

Remove the seat and fuel tank.
Disconnect the wire coupler and remove the CDI unit.

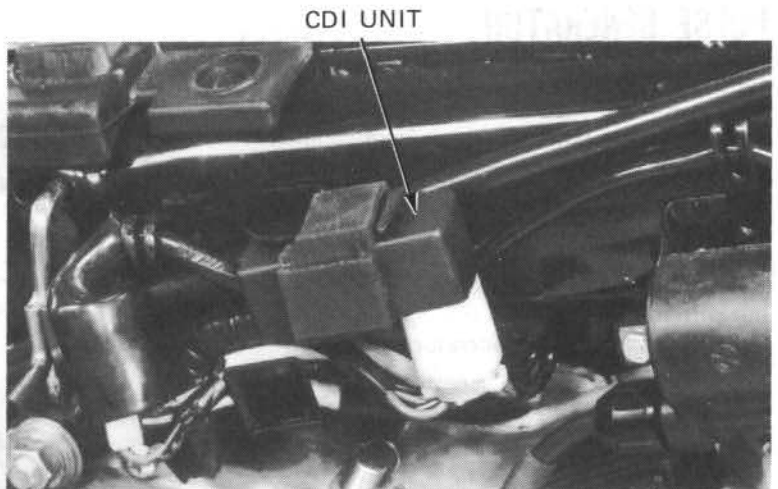

IGNITION SYSTEM

INSPECTION

Disconnect the wires and check continuity of the CDI terminals. Replace the CDI unit if the readings are not within the limits shown in the table.

NOTE

- The CDI unit is fully transistorized.
- For accurate testing, it is necessary to use a specified electric tester. Use of an improper tester may give false readings.
- Use a Sanwa Electric Tester (P/N 07308-0020000), Kowa Electric Tester (TH-5H) or Kowa Digital Multi-Tester (KS-AHM-32-003).

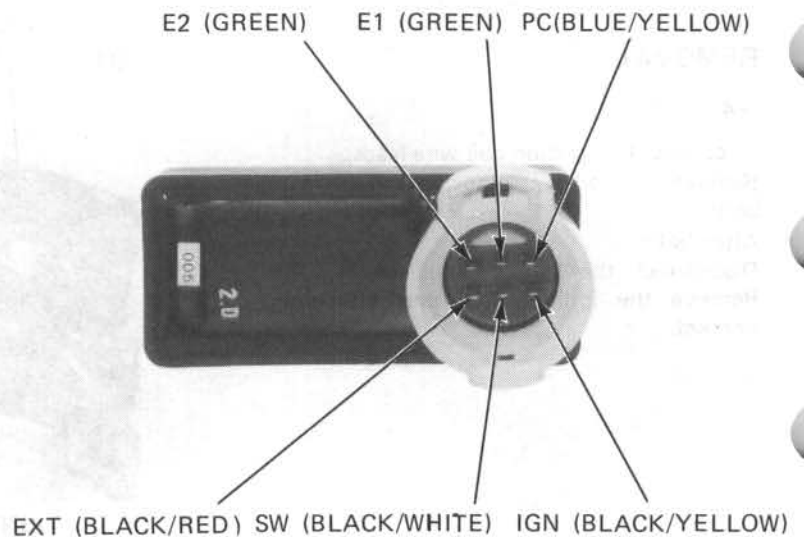

-Probe \ +Probe	SW (Bk)	EXT (Bk/R)	PC (Bu/Y)	E1 (G) E2 (G)	IGN (Bk/Y)
SW (Bk)		∞	∞	∞	∞
EXT (Bk/R)	0.1-20		∞	∞	∞
PC (Bu/Y)	0.5-200	0.5-100		1-5	∞
E1(G) E2(G)	0.2-60	0.1-2.0	∞		∞
IGN (Bk/Y)	∞	∞	∞	∞	

PULSE GENERATOR

INSPECTION

Disconnect the pulse generator wire coupler. Measure the resistance between the green and blue/yellow wires.

RESISTANCE: 90 ohms

Replace the pulse generator if the reading is not within the limit.

See Section 6 for pulse generator replacement.

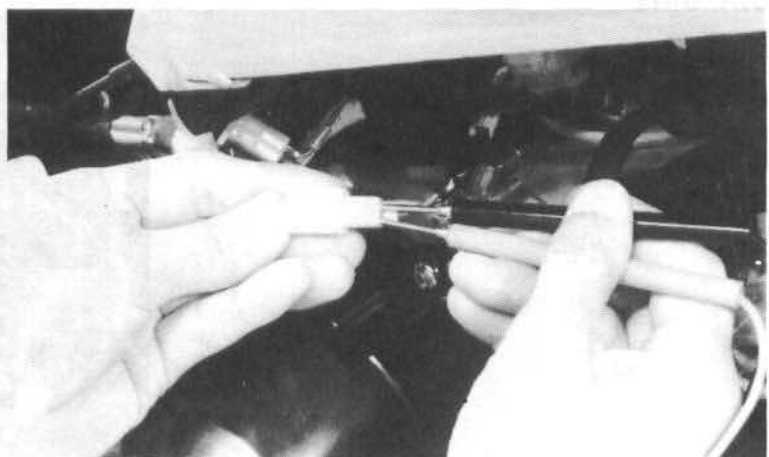

IGNITION TIMING

Remove the timing hole cap.
Connect a timing light.
Start the engine and allow it to idle.

IDLE (1,700 rpm): "F" mark should be aligned with the index mark

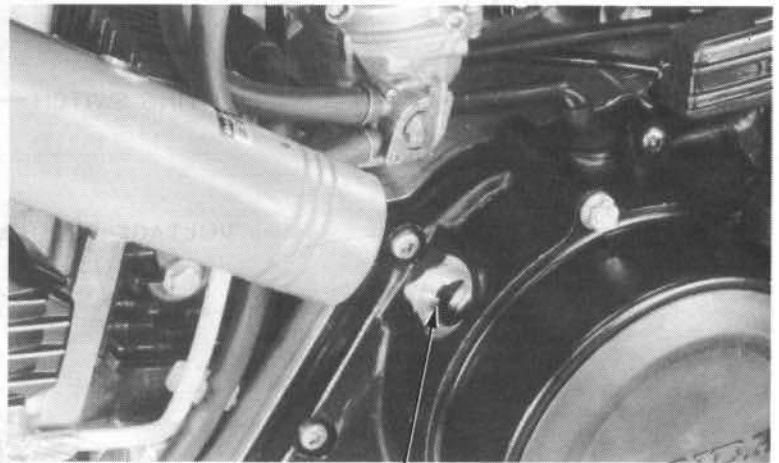

INDEX MARK

To adjust, remove the pulse generator cover. Loosen the base plate attaching screws and turn the plate left or right as required.

If ignition timing cannot be corrected, inspect the CDI unit and pulse generator. Replace any faulty components.

Maintain a pulse rotor-to-generator air gap of 0.3–0.4 mm (0.01–0.02 in).

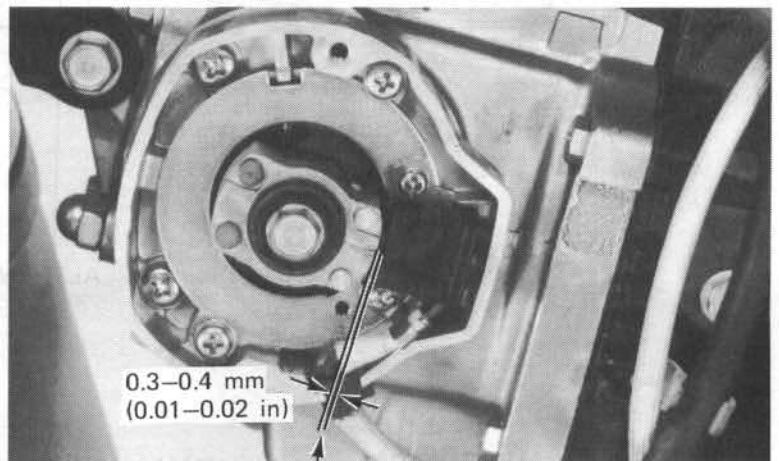

AIR GAP

BATTERY/CHARGING SYSTEM

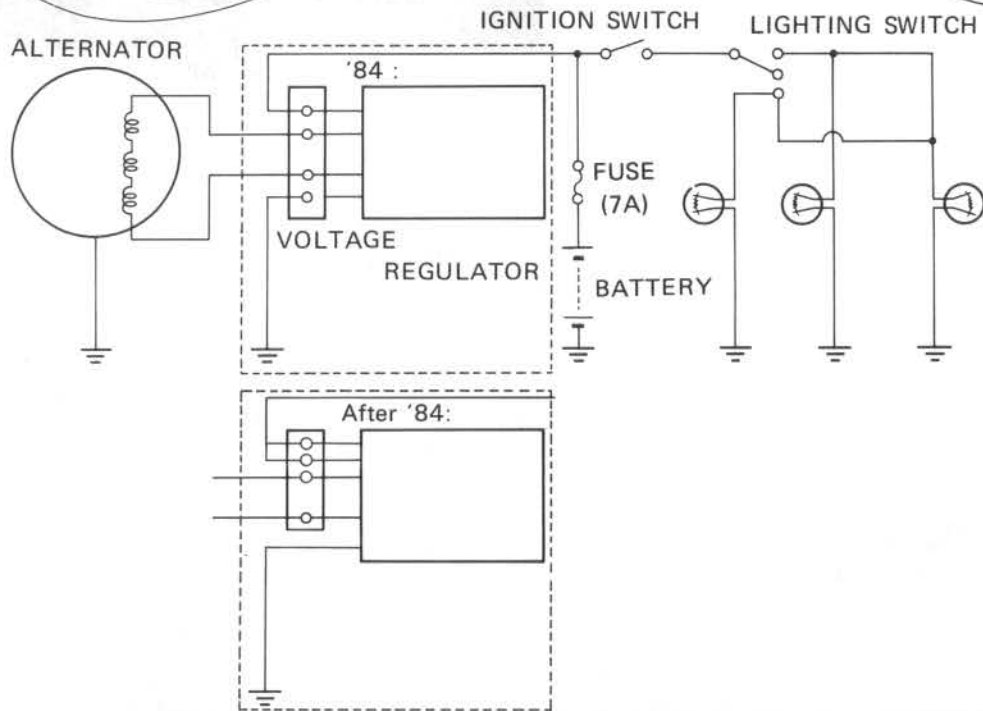
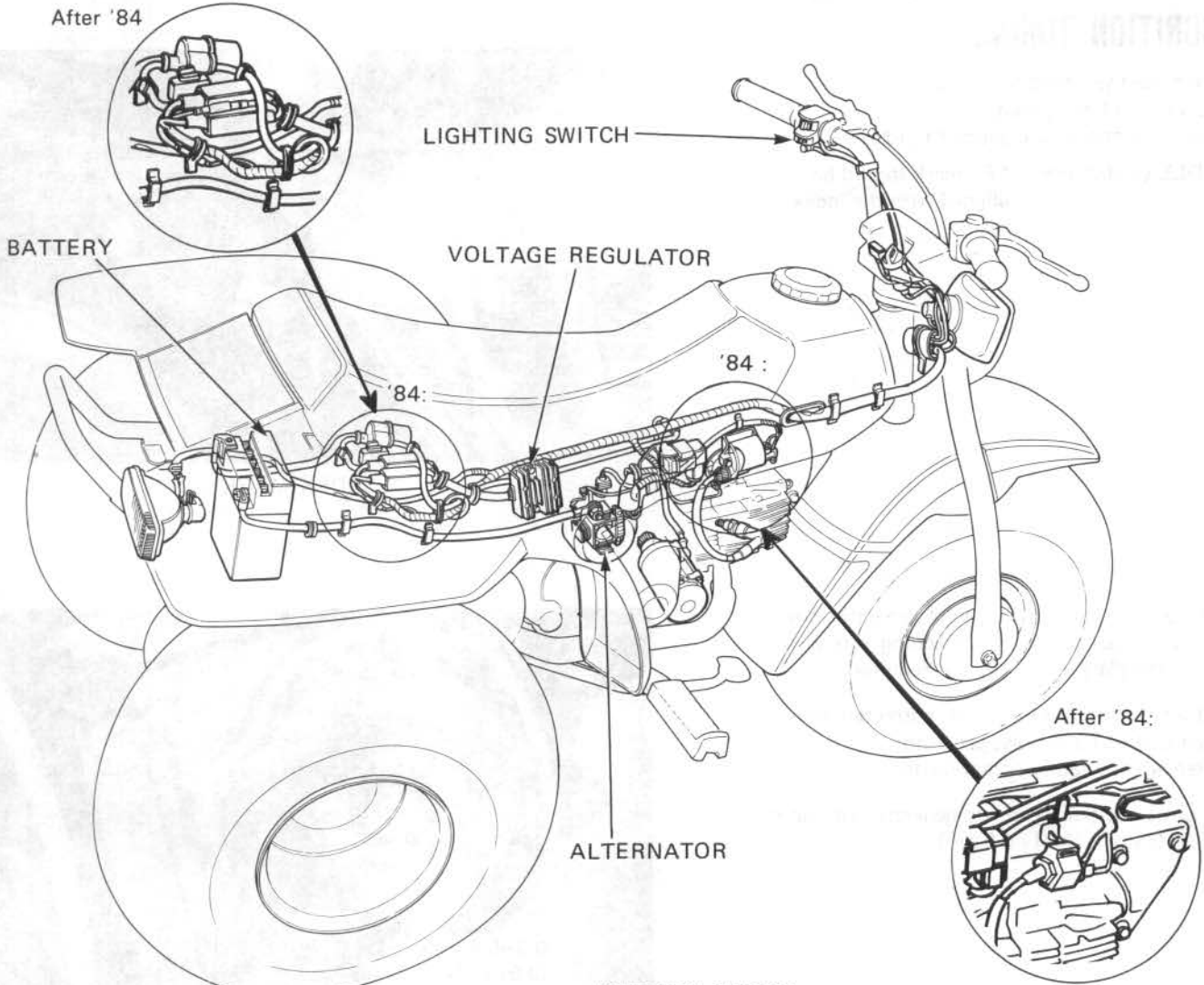

16. BATTERY / CHARGING SYSTEM

SERVICE INFORMATION	16-1
TROUBLESHOOTING	16-2
BATTERY	16-3
CHARGING SYSTEM	16-4

SERVICE INFORMATION

GENERAL

- Battery fluid level should be checked regularly. Fill with distilled water when necessary.
- Quick charge a battery, only in an emergency. Slow-charging is preferred.
- Remove the battery from the ATC for charging. If the battery must be charged on the ATC, disconnect the battery cables.

WARNING

Do not smoke, and keep flames away from a charging battery. The gas produced by a battery will explode if a flame or spark is brought near.

- All charging system components can be tested on the ATC.

SPECIFICATIONS

Battery	Capacity	12V-9 ampere-hours
	Specific gravity	1,270-1,290 (20°C, 68°F)
	Charging rate	0.9 ampere maximum
Alternator	Capacity	LIGHT ON: 4.5 amperes /5,000 rpm (14 volts)
Voltage regulator		Transistorized non-adjustable regulator

TROUBLESHOOTING

No power – key turned on:

1. Dead battery
 - Low fluid level
 - Low specific gravity
 - Charging system failure
2. Disconnected battery cable
3. Burnt fuse
4. Faulty ignition switch

Low power – key turned on:

1. Weak battery
 - Low fluid level
 - Low specific gravity
 - Charging system failure
2. Loose battery connection

Low power – engine running:

1. Battery undercharged
 - Low fluid level
 - One or more dead cells
2. Charging system failure
3. Loose connection or short circuit in lighting system

Intermittent power:

1. Loose battery connection
2. Loose charging system connection
3. Loose starting system connection

Charging system failure:

1. Loose, broken, or shorted wire or connection
2. Faulty voltage regulator
3. Faulty alternator

BATTERY REMOVAL

- Remove the seat and rear fender.
- Remove the battery holder and cover.
- Disconnect the ground cable at the battery.
- Disconnect the positive cable at the battery.
- Remove the battery.

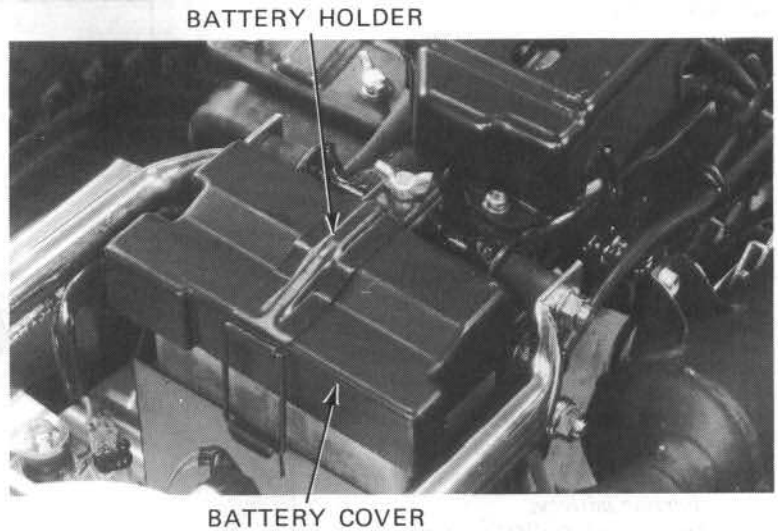

TESTING SPECIFIC GRAVITY

Test each cell with a hydrometer.

SPECIFIC GRAVITY: 1.270–1.290 (20°C, 68°F)

1.270–1.290	Fully charged
Below 1.260	Undercharged

NOTE

- The battery must be recharged if the specific gravity is below 1.230.
- The specific gravity varies with the temperature as shown in the accompanying table.
- Replace the battery if sulfation is evident or if the space below the cell plates is filled with sediment.

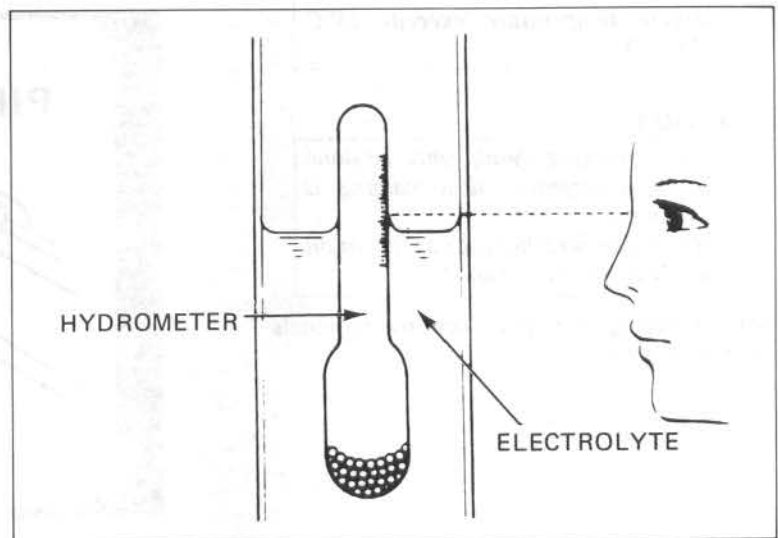

WARNING

The battery contains sulfuric acid. Avoid contact with skin, eyes, or clothing. Antidote: Flush with water and get prompt medical attention if it gets in your eyes.

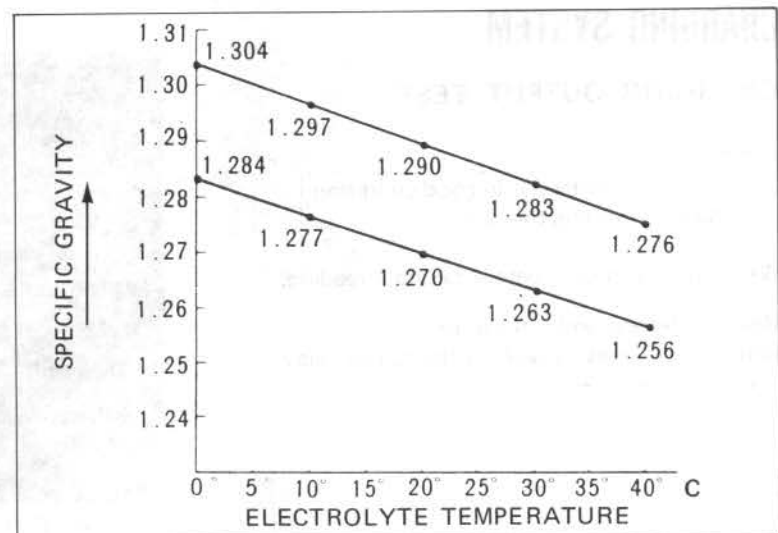

BATTERY/CHARGING SYSTEM

CHARGING

Connect the charger positive (+) cable to the battery positive (+) terminal.

Connect the charger negative (-) cable to the battery negative (-) terminal.

Charging current: 0.9 ampere max.

Charging: Charge the battery until specific gravity is 1.270–1.290 at 20°C (68°F)

WARNING

- Before charging a battery, remove the cap from each cell.
- Keep flames and sparks away from a charging battery.
- Turn power ON/OFF at the charger, not at the battery terminals.
- Discontinue charging if the electrolyte temperature exceeds 45°C (113°F).

CAUTION

- Quick-charging should only be done in an emergency; slow-charging is preferred.
- Route the breather tube as shown on the battery caution label.

After installing the battery, coat the terminals with clean grease.

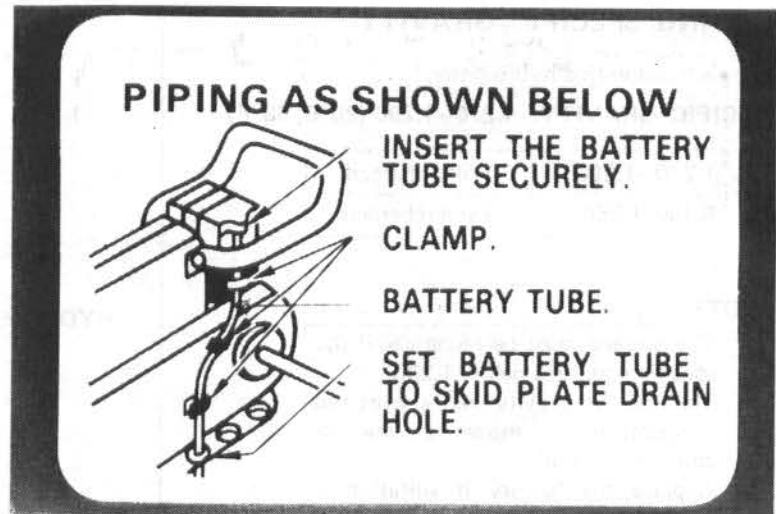
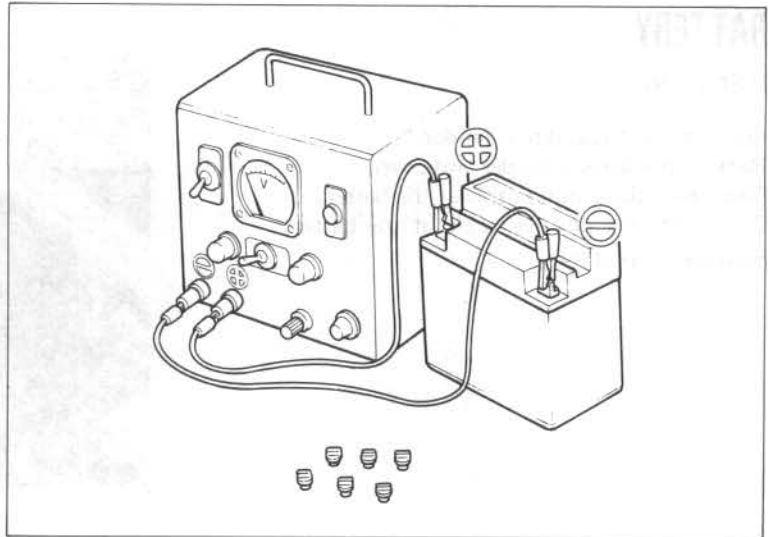

CHARGING SYSTEM

CHARGING OUTPUT TEST

NOTE

Be sure the battery is in good condition before performing this test.

Warm up the engine before taking a reading.

Remove the seat and rear fender.

Remove the screw attaching the starter relay cover and the cover.

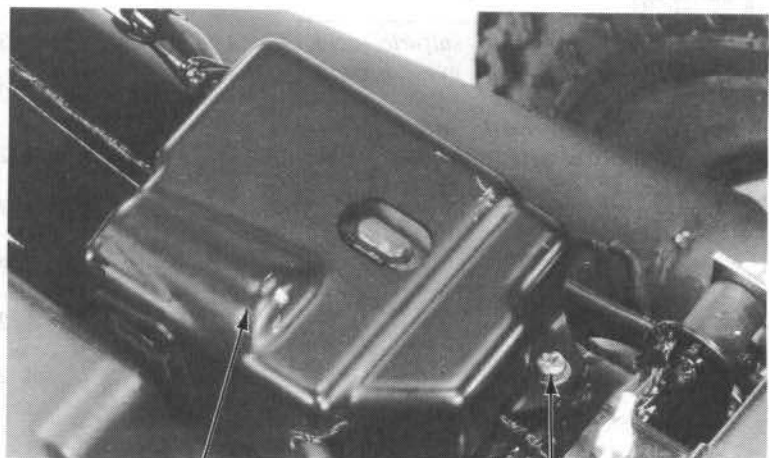

STARTER RELAY COVER

SCREW

Remove the battery holder and cover.

Disconnect the red wire at the fuse.

Connect an ammeter between the red wires.
Connect a voltmeter between the battery positive and negative terminals.
Start the engine

TECHNICAL DATA:

4.5A/5,000 rpm (14V) at
LIGHT ON

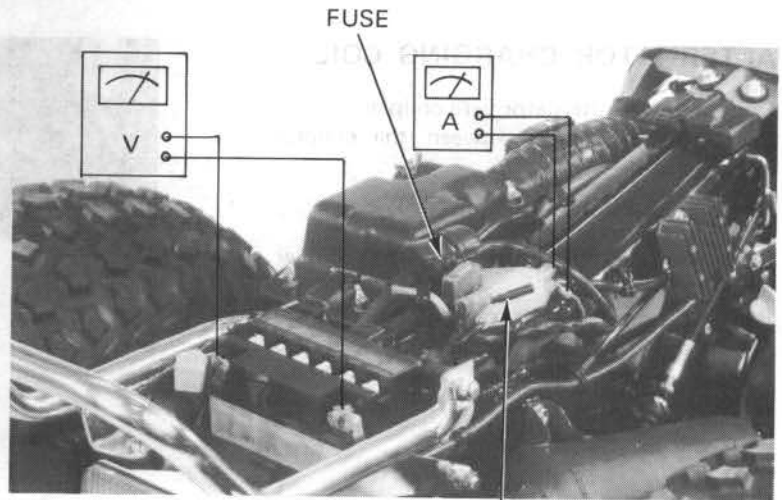

RED WIRES

VOLTAGE REGULATOR

Remove the seat and rear fender.
Disconnect the voltage regulator coupler.
Check the resistance between the leads with an ohmmeter.

Range: Sanwa: $k\Omega$
Kowa: 100Ω

VOLTAGE REGULATOR

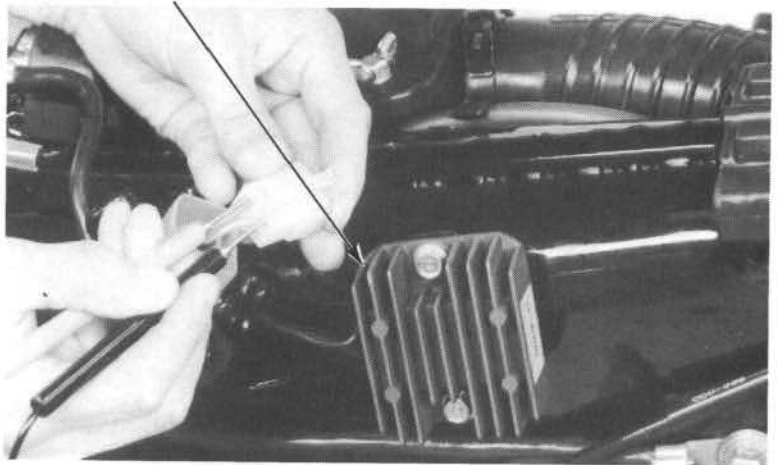

'84: k ohms

+Probe -Probe	Yellow	Yellow	Green	Red
Yellow		1-50	0.5-50	0.1-10
Yellow	1-50		0.5-50	0.1-10
Green	0.1-10	0.1-10		0.2-30
Red	∞	∞	∞	

After '84: k ohms

+Probe -Probe	Yellow	Yellow	Green	Red	Black
Yellow		∞	∞	1-20	∞
Yellow	∞		∞	1-20	∞
Green	1-20	1-20		3-100	0.20
Red	∞	∞	∞		∞
Black	1-50	1-50	0.2-10	3-10	

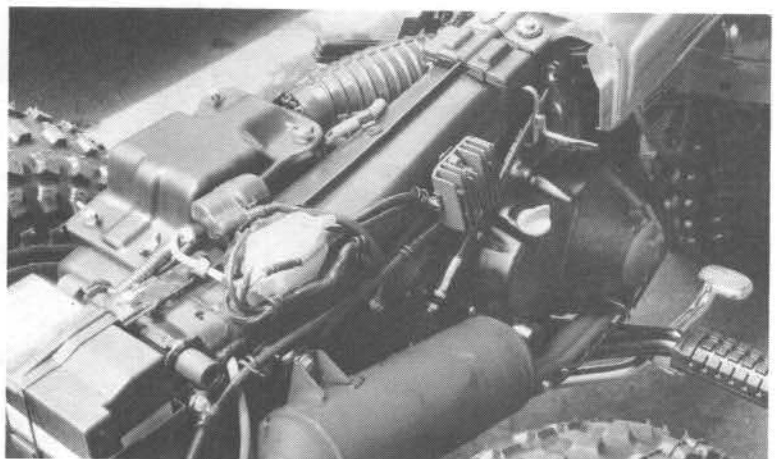

ALTERNATOR CHARGING COIL

Disconnect the alternator wire coupler.
Check the resistance between the coupler terminals.

RESISTANCE: 0.5–1.5 ohms

Check for continuity between the coupler terminal and ground.

Replace the alternator stator if readings are not within the limit or if any lead has continuity to ground. See Stator Removal (Page 9–6).

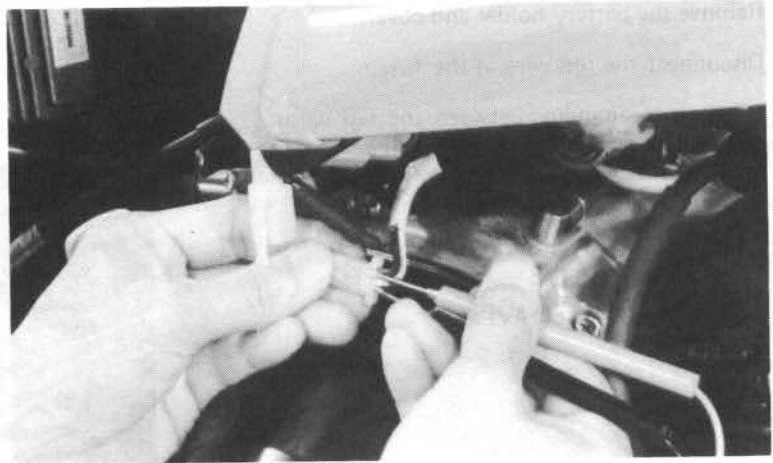

MEMO

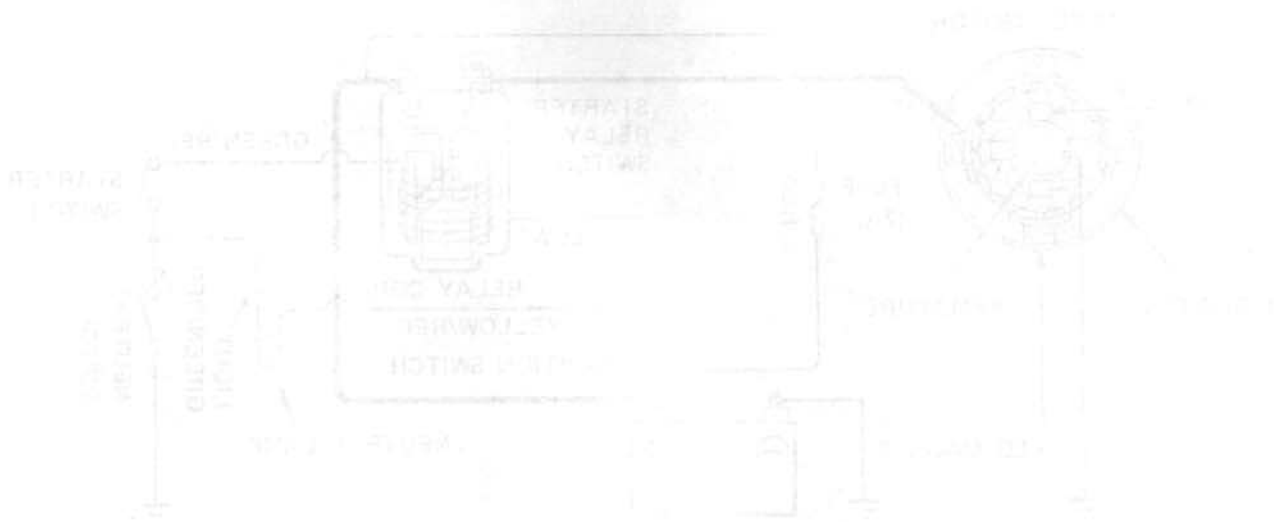

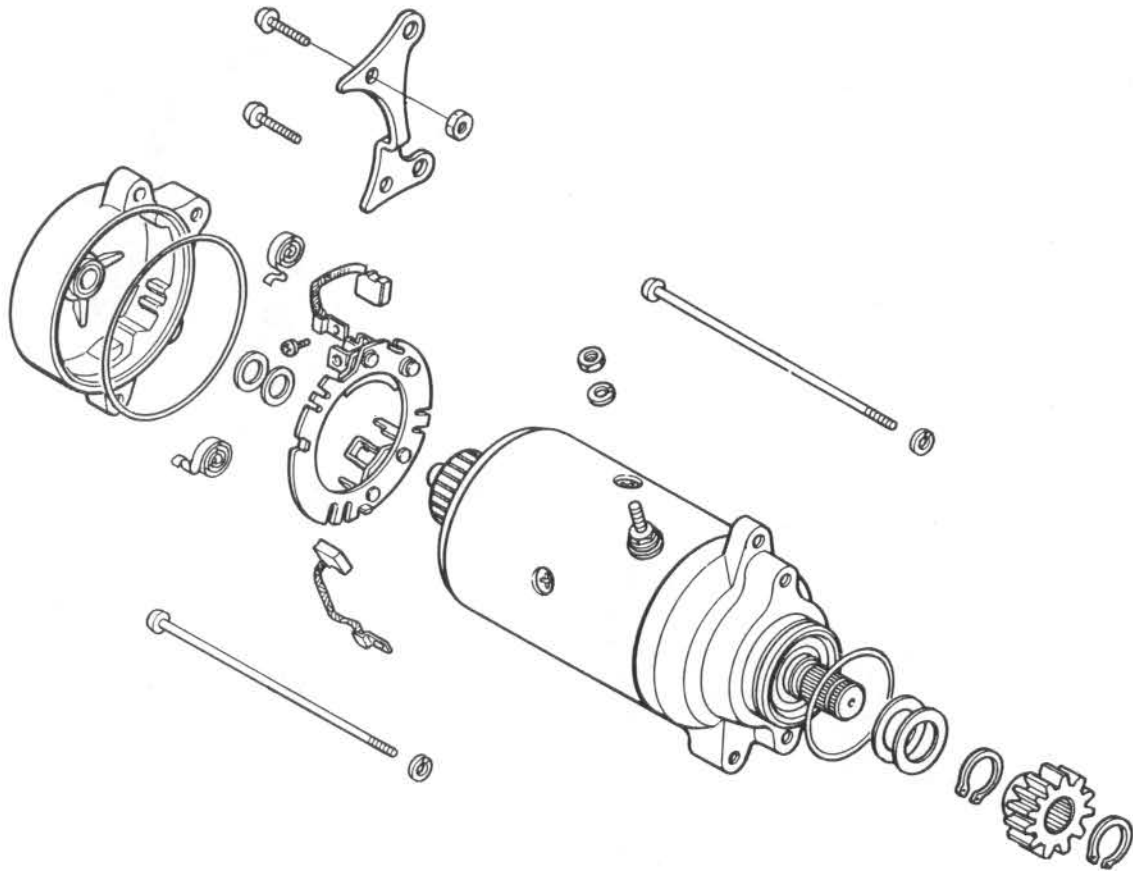
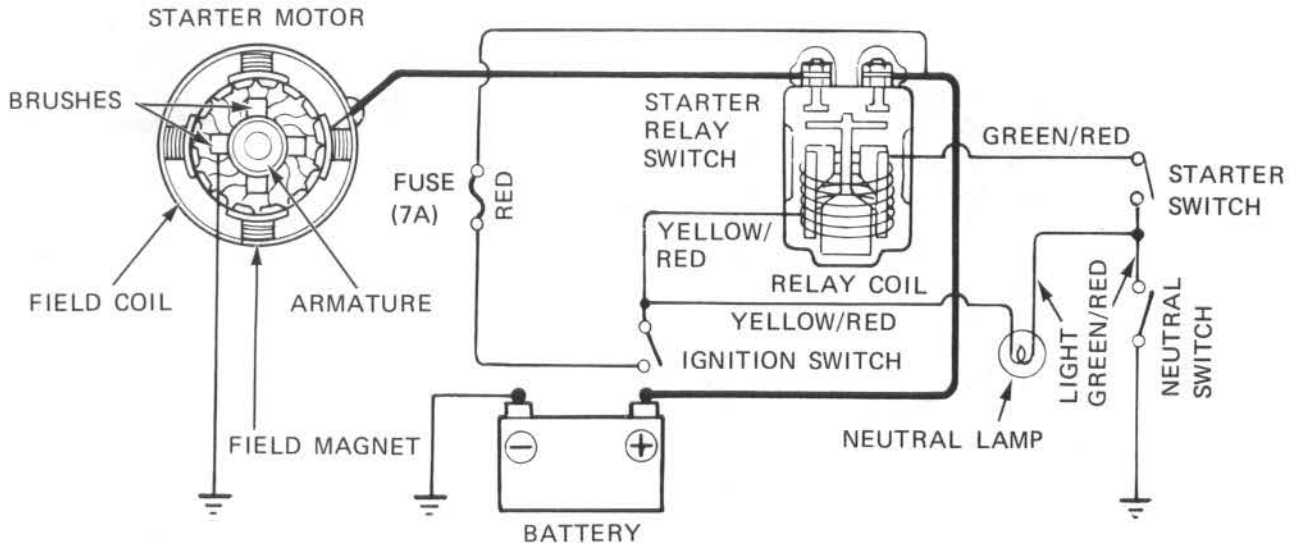

17. STARTER SYSTEM

SERVICE INFORMATION	17-1
TROUBLESHOOTING	17-1
STARTER MOTOR	17-2
STARTER RELAY SWITCH	17-4

SERVICE INFORMATION

GENERAL

- The starter motor can be removed with the engine in the frame.

SPECIFICATIONS

	ITEM	STANDARD	SERVICE LIMIT
Starter motor	Brush spring tension	495–605 g (1.09–1.33 lb)	410 g (0.90 lb)
	Brush length	12–13 mm (0.47 – 0.51 in)	6.5 mm (0.26 in)

TROUBLESHOOTING

Starter motor will not turn

1. Dead battery
2. Faulty ignition switch
3. Faulty starter switch
4. Faulty neutral switch
5. Faulty starter relay switch
6. Loose or disconnected wire or cable

Starter motor turns engine slowly

1. Low battery.
2. Excessive resistance in circuit
3. Binding in starter motor

Starter motor turns, but engine does not turn

1. Faulty starter clutch
2. Faulty starter motor gears
3. Faulty starter motor or idle gear

Starter motor and engine turn, but engine does not start

1. Faulty ignition system
2. Engine problems.
3. Faulty engine stop switch

STARTER MOTOR

REMOVAL

CAUTION

With the ignition switch OFF, remove the negative cable at the battery before servicing the starter motor.

Remove the exhaust pipe (Page 14-2).
 Disconnect the starter cable.
 Remove the starter motor mounting screws and bracket and pull the motor out of the engine case.

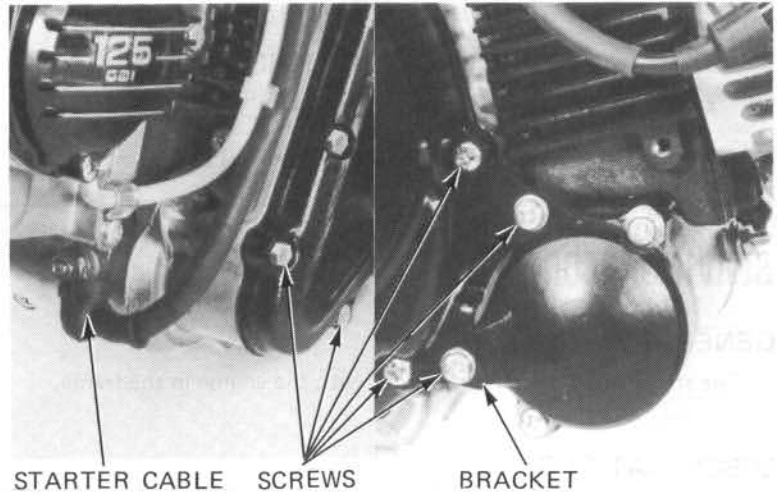

BRUSH INSPECTION

Remove the starter motor case screws and rear cover.

Inspect the brushes and measure the brush length.

Measure brush spring tension with a spring scale.

SERVICE LIMITS:

Brush length: 6.5 mm (0.26 in)
Brush spring tension: 410 g (14.5 oz)

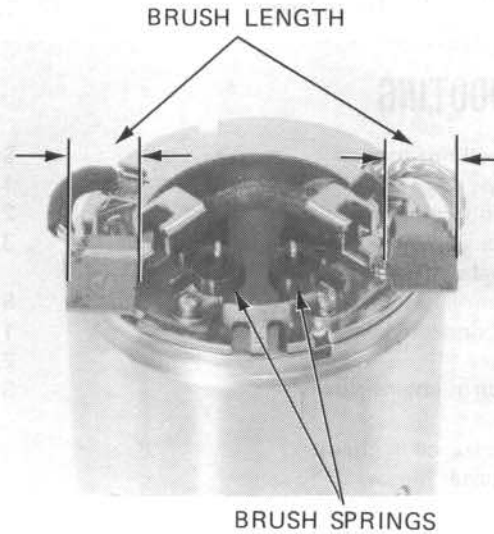

COMMUTATOR INSPECTION

Remove the starter motor case.

NOTE

Record the location and number of thrust washers.

Inspect the commutator bars for discoloration. Bars discolored in pairs indicate grounded armature coils, in which case the starter motor must be replaced.

NOTE

Do not use emery or sand paper on the commutator.

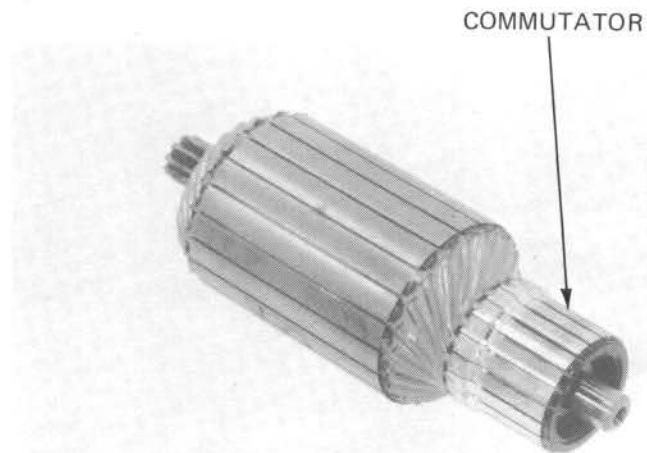

Check for continuity between pairs of commutator bars. Also, make a resistance check between individual commutator bars and the armature shaft. There should be no continuity.

CONTINUITY BETWEEN
COMMUTATOR BAR PAIRS: NORMAL

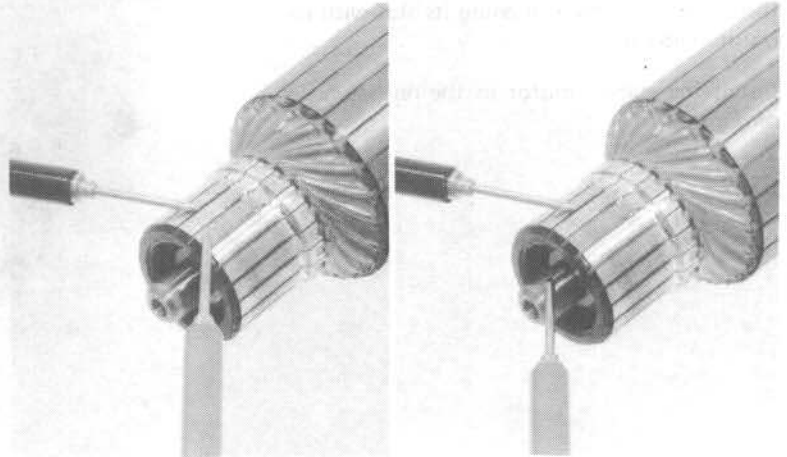

NO CONTINUITY BETWEEN
COMMUTATOR BARS AND ARMATURE SHAFT: NORMAL

NO CONTINUITY BETWEEN
CABLE TERMINAL AND MOTOR CASE: NORMAL

FIELD COIL INSPECTION

Check for continuity from the cable terminal to the motor case and from the cable terminal to the brush wire. Replace the starter motor if the field coil does not have continuity or if it is shorted to the motor case.

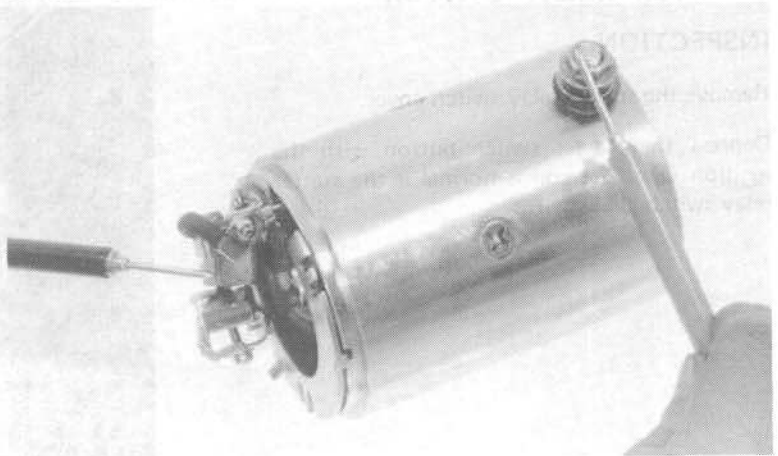

CONTINUITY BETWEEN
CABLE TERMINAL AND BRUSH WIRE (INSULATED): NORMAL

ASSEMBLY/INSTALLATION

Assemble the starter motor. Align the case notch with the brush holder pin.

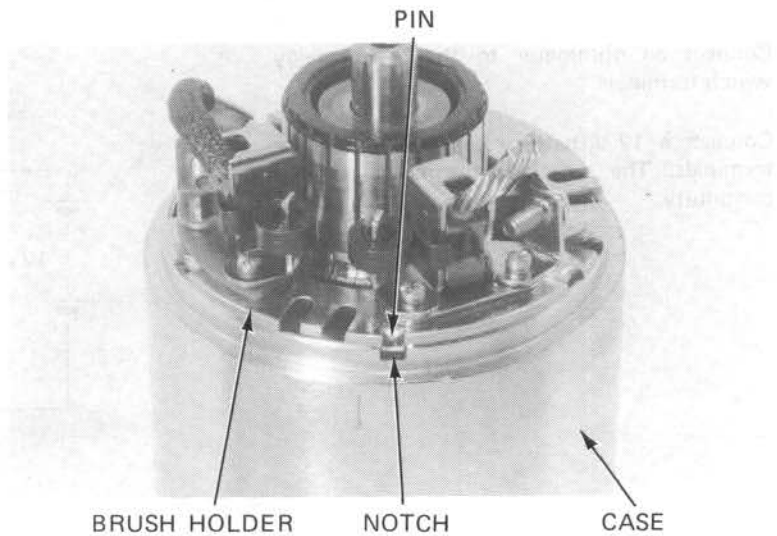

STARTER SYSTEM

Install the rear cover aligning its slot with the brush holder pin.

Install the starter motor in the reverse order of removal.

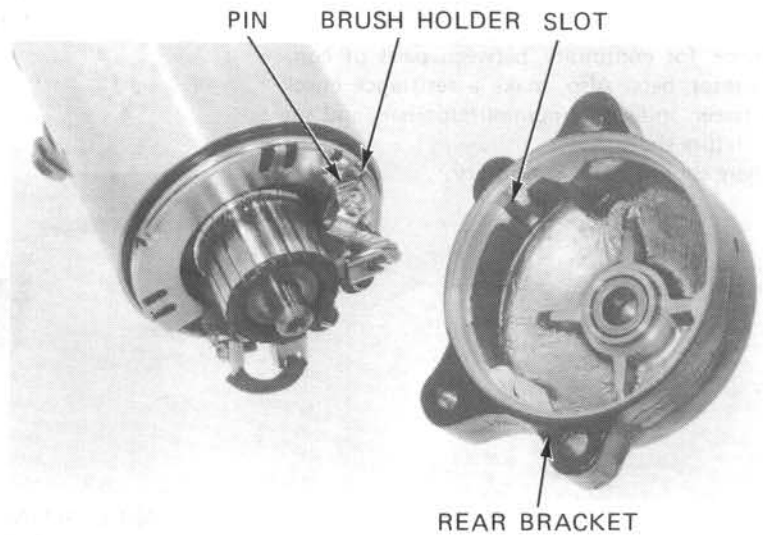

STARTER RELAY SWITCH

INSPECTION

Remove the starter relay switch cover.

Depress the starter switch button with the ignition ON. The coil is normal if the starter relay switch clicks.

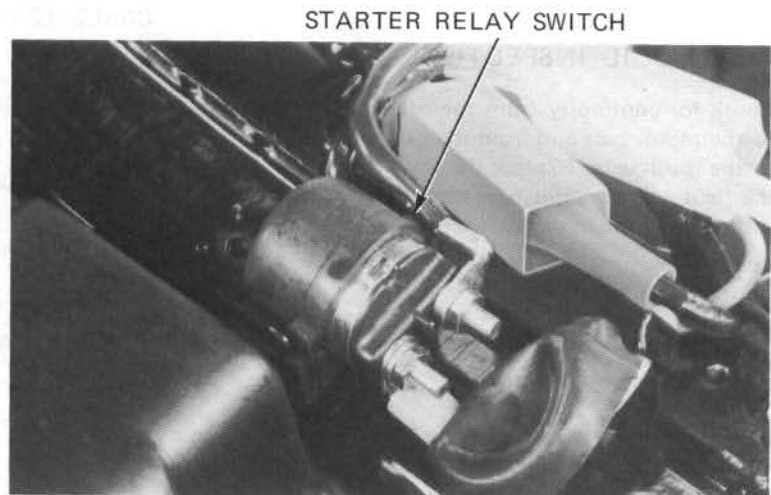

Connect an ohmmeter to the starter relay switch terminals.

Connect a 12 V battery to the switch wire terminals. The switch is normal if there is continuity.

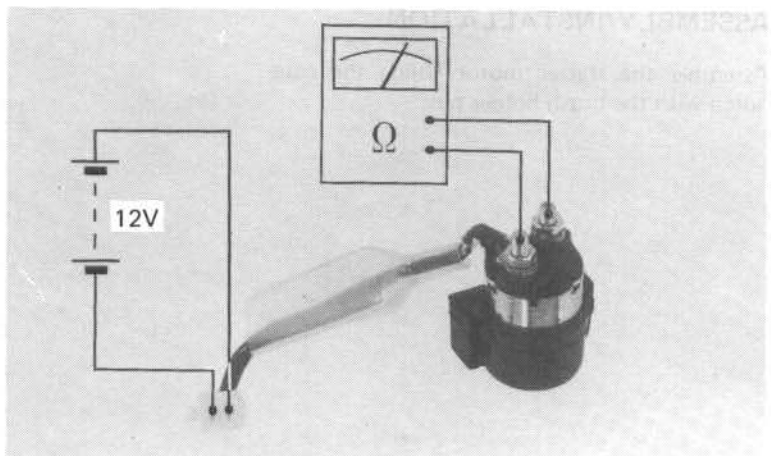

18. LIGHTS / SWITCHES

SERVICE INFORMATION	18-1
TROUBLESHOOTING	18-1
HEADLIGHT	18-2
TAILLIGHT	18-3
NEUTRAL INDICATOR LIGHT	18-3
IGNITION SWITCH	18-5
HANDLEBAR SWITCHES	18-6
WIRING DIAGRAM	18-8

SERVICE INFORMATION

GENERAL

- A continuity check can usually be made without removing the part from the ATC by simply disconnecting the wires and connecting a continuity tester or voltmeter to the terminals.

SPECIFICATIONS

Headlight	12V 45/45W
Taillight	12V 5W

TROUBLESHOOTING

Light does not come on when light switch is turned on (Engine is running)

1. Bulb burned out
2. Faulty switch
3. Wiring to that component has open circuit

Headlight beams do not shift when hi-lo switch is operated

1. Faulty dimmer switch
2. Bulb burned out
3. Wiring to that component has open circuit

HEADLIGHT

REMOVAL

Remove the two headlight mounting screws. Disconnect the headlight wires and remove the headlight.

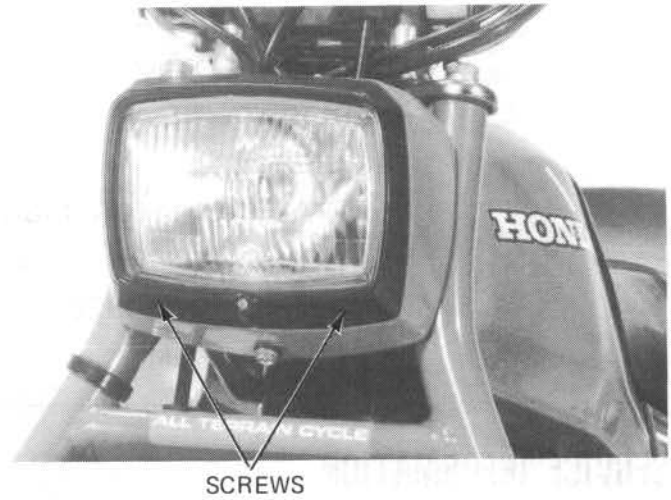

DISASSEMBLY/ASSEMBLY

Remove the two retaining screws and adjusting screw and remove the headlight unit from the rim.

Assembly is the reverse of disassembly.

CASE REMOVAL/INSTALLATION

Remove the headlight. Remove the three case mounting bolts and the headlight case.

Installation is the reverse of removal.

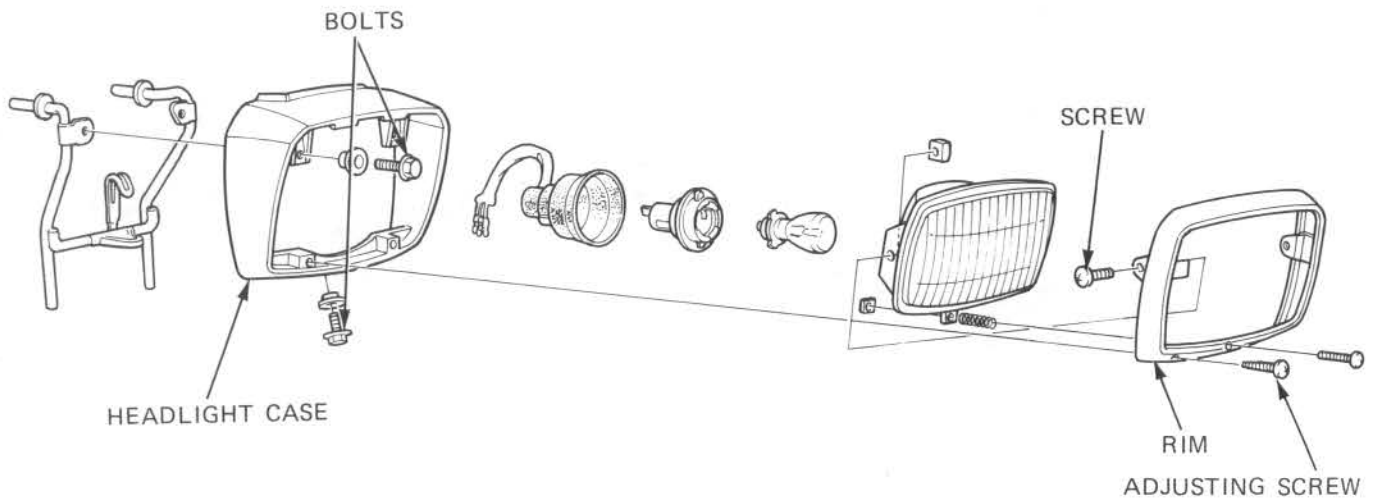

TAILLIGHT

REMOVAL/INSTALLATION

Remove the seat and rear fender.
Remove the two taillight mounting screws and remove the taillight and lens.

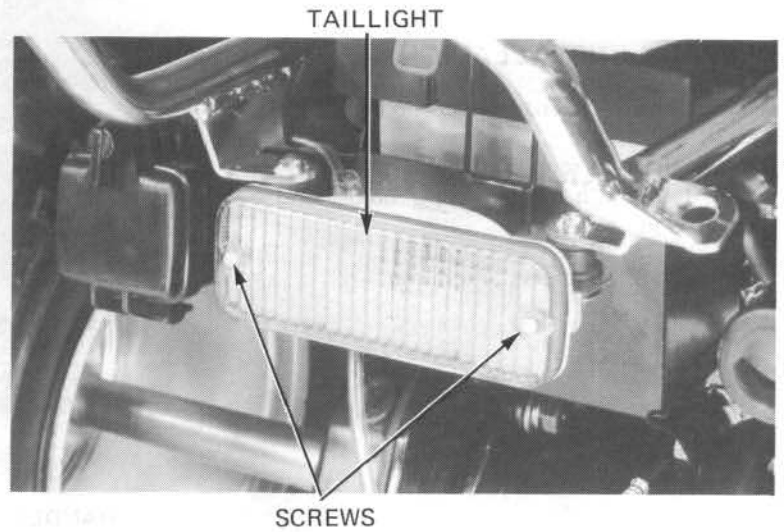

Replace the bulb if necessary.
Disconnect the taillight wires and remove the taillight.
Installation is the reverse of removal.

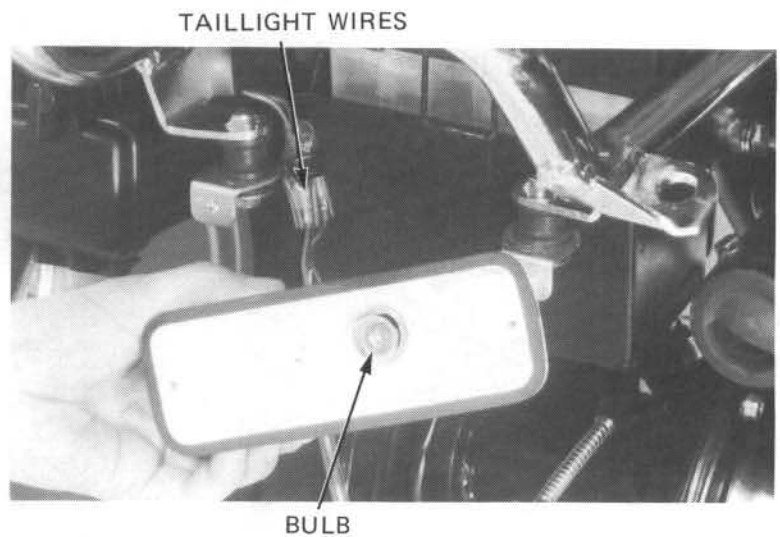

NEUTRAL INDICATOR LIGHT

BULB REPLACEMENT

Pull the bulb socket from the neutral indicator light panel.
Replace the bulb with a new one.
Install the bulb socket.

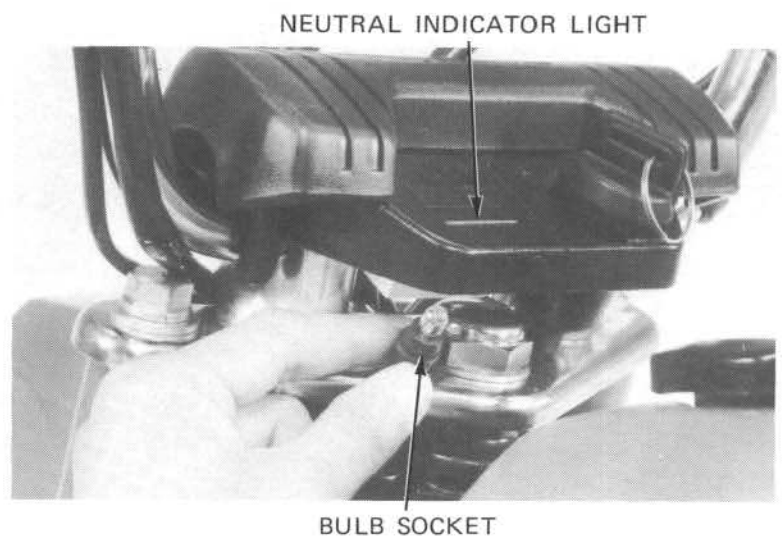

REMOVAL/INSTALLATION

Remove the handlebar upper holder (Page 12-3).

Remove the two screws attaching the indicator light to the handlebar upper holder and the light unit.

Installation is the reverse of removal.

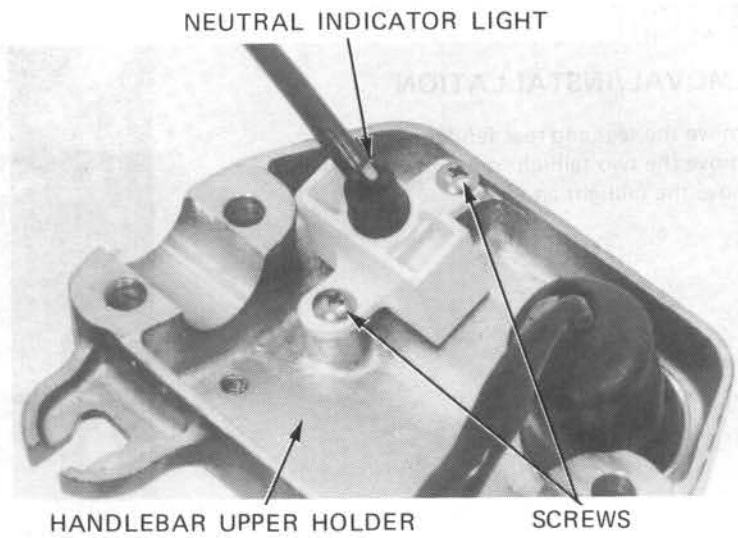

NEUTRAL SWITCH INSPECTION

Disconnect the neutral switch wire connector. Check the switch for continuity between the switch wire (Light green/red) and ground with the transmission in neutral and with the transmission in any gear.

Replace the neutral switch, if necessary (Page 9-10).

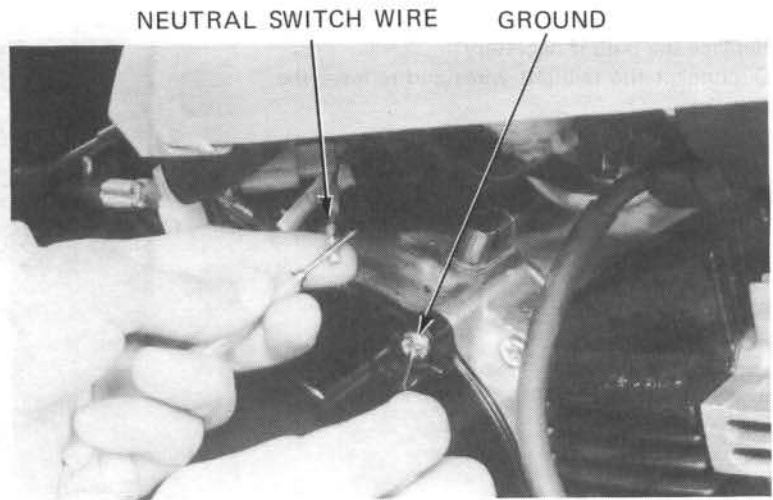

IN NEUTRAL: CONTINUITY
IN ANY GEAR: NO CONTINUITY

IGNITION SWITCH

Remove the headlight and disconnect the ignition switch wire connectors. Check continuity of the ignition switch wires in each switch position.

SWITCH POSITION:

'84:

OFF: Black to Green – continuity

ON: Red to Yellow/Red – continuity

Terminal Position	IG	E	BAT	HO
OFF	○	○		
ON			○	○
Color	Black	Green	Red	Yellow/Red

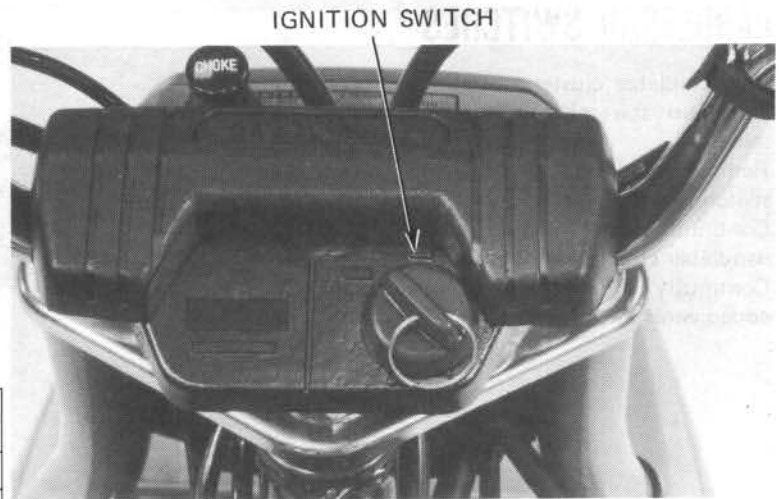

After '84:

OFF: Black/white to Green—continuity

ON: Red to Black—continuity

Terminal Position	IG	E	BAT	HO
OFF	○	○		
ON			○	○
Color	Black/white	Green	Red	Black

REMOVAL/INSTALLATION

Remove the handlebar upper holder (Page 12-3).

Release the notches on the ignition switch and remove the switch from the handlebar upper holder.

Installation is the reverse of removal.

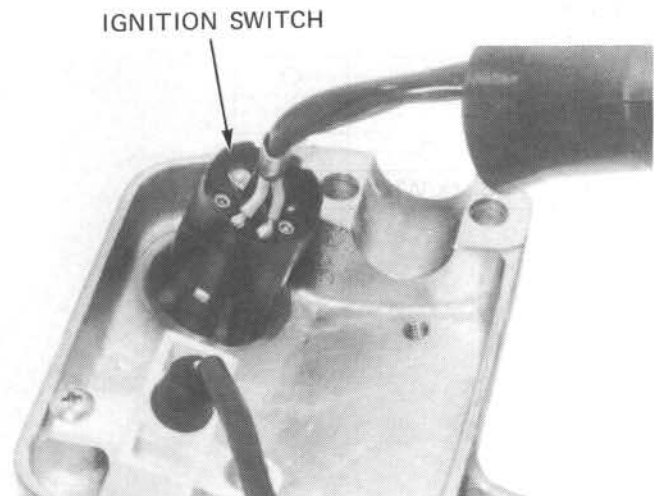

HANDLEBAR SWITCHES

The handlebar cluster switches (lights, engine stop and starter) must be replaced as assemblies.

Remove the headlight and disconnect the switch wires.

Continuity tests for the components of the handlebar cluster switches follow:

Continuity should exist between the color coded wires in each chart.

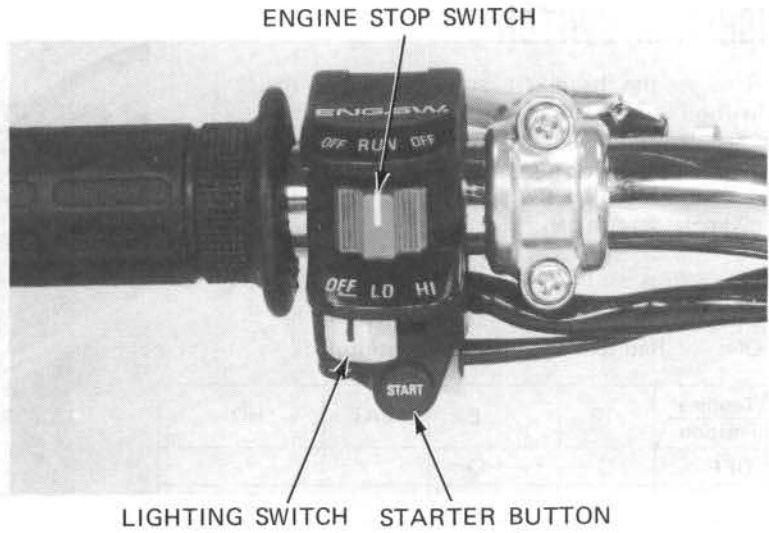

ENGINE STOP SWITCH

'84:
 RUN: No continuity
 OFF: Black/white to Green

Terminal Position	IG	E
OFF	○—○	○
RUN		
OFF	○—○	○
Color	Black	Green

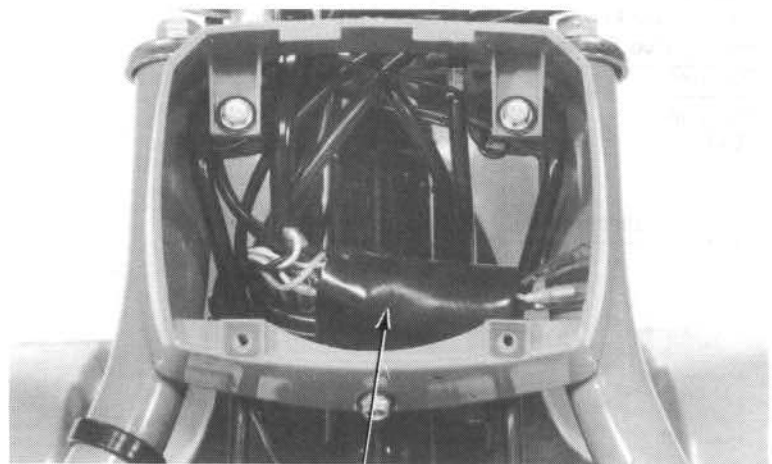

WIRE CONNECTORS

After '84:
 RUN: No continuity
 OFF: Black/White to Green

Terminal Position	IG	E
OFF	○—○	○
RUN		
OFF	○—○	○
Color	Black/White	Green

LIGHTING SWITCH

OFF: No continuity
 LO: Brown to Yellow to White
 MIDDLE (N): Brown to Yellow to White to Blue
 HI: Brown to Yellow to Blue

Terminal Position	TL	C	LO	HI
OFF				
LO	○	○	○	
(N)	○	○	○	○
HI	○	○		○
Color	Brown	Yellow	White	Blue

After '84:
 OFF: No continuity
 LO: Brown to Black/Brown to White
 MIDDLE(N): Brown to Black/Brown to White to Blue
 HI: Brown to Black/Brown to Blue

Terminal Position	TL	C	LO	HI
OFF				
LO	○	○	○	
(N)	○	○	○	○
HI	○	○		○
Color	Brown	Black/Brown	White	Blue

STARTER BUTTON

Green/Red to Light Green/Red with the button depressed.
 No continuity with the button released.

Terminal Position	ST	E
Out		
Start	○	○
Color	Green/Red	Light green/Red

WIRING DIAGRAMS

'84:

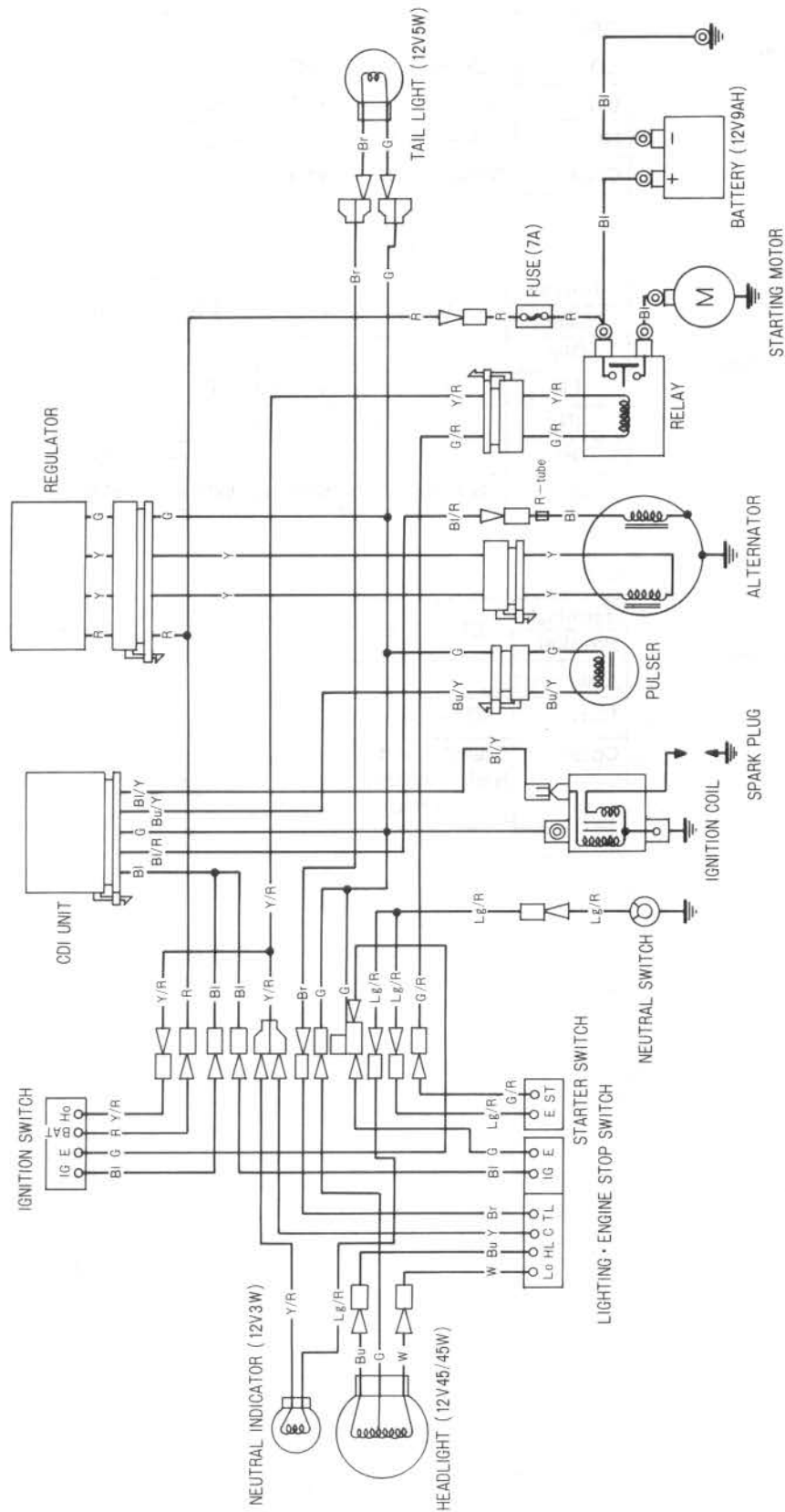

- Br Brown
- O Orange
- Lb Light blue
- Lg Light green
- P Pink
- Gr Gray
- Bi Black
- Y Yellow
- Bu Blue
- G Green
- R Red
- W White

STARTER SWITCH

	ST	E
FREE		
PUSH		
COLOR	G/R	Lg/R

ENGINE STOP SWITCH

	IG	E
OFF		
RUN		
COLOR	BI	G

LIGHTING SWITCH

	TL	C	L0	HL
OFF				
L0				
(N)				
HL				
COLOR	Br	Y	W	Bu

IGNITION SWITCH

	IG	E	BAT	H0
OFF				
ON				
COLOR	BI	G	R	Y/R

After '84:

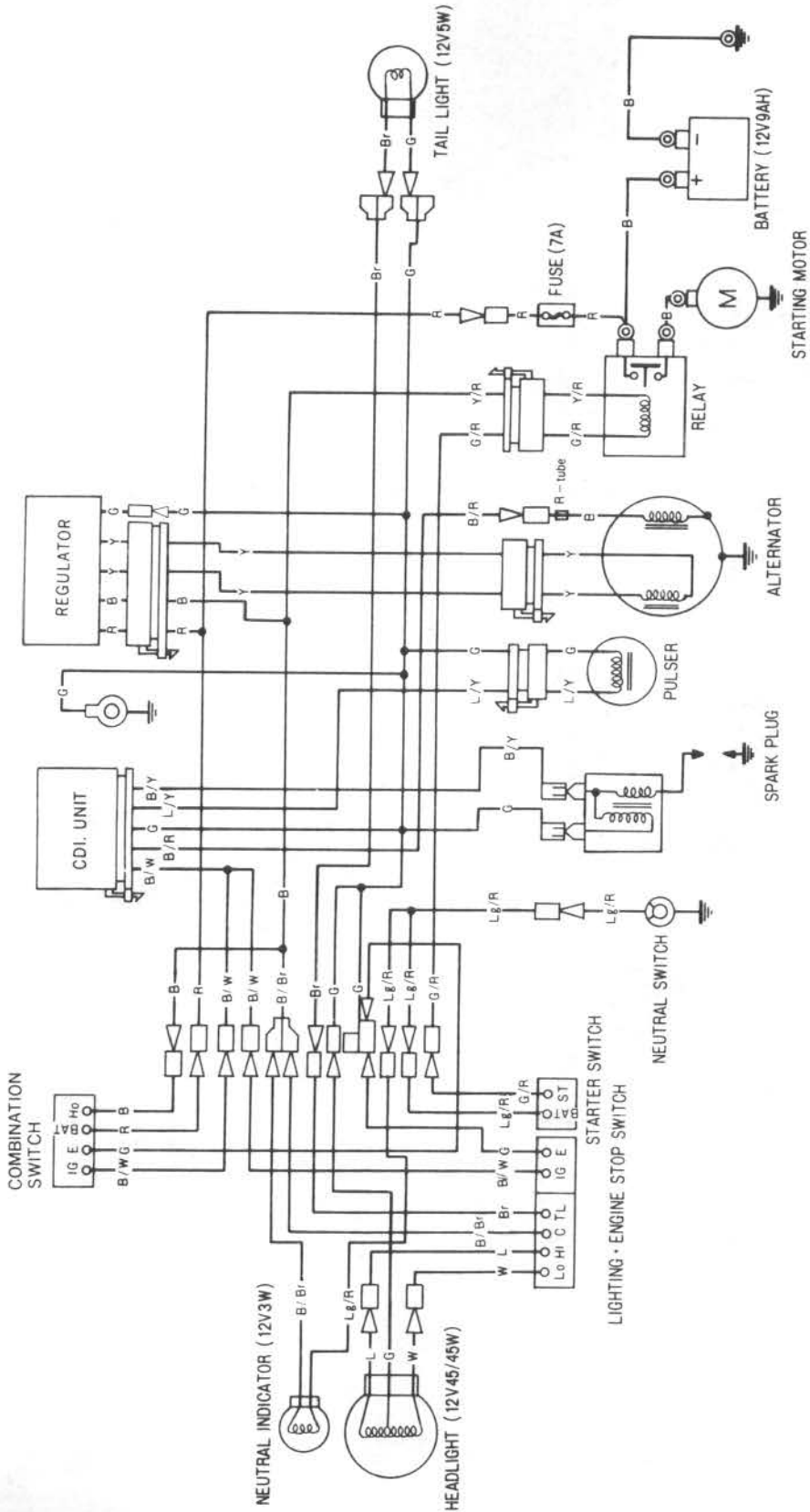

- Br Brown
- O Orange
- Lb Light blue
- Lg Light green
- P Pink
- Gr Gray

- B Black
- Y Yellow
- L Blue
- G Green
- R Red
- W White

STARTER SWITCH

	ST	BAT
	FREE	
	PUSH	
COLOR	G/R	Lg/R

ENGINE STOP SWITCH

	IG	E
	OFF	
	RUN	
COLOR	B/W	G

LIGHTING SWITCH

	TL	C	Lo	Hi
	OFF			
	Lo			
	(N)			
	Hi			
COLOR	Br	B/Br	W	L

COMBINATION SWITCH

	IG	E	BAT	Ho
	OFF			
	ON			
COLOR	B/W	G	R	B

MEMO

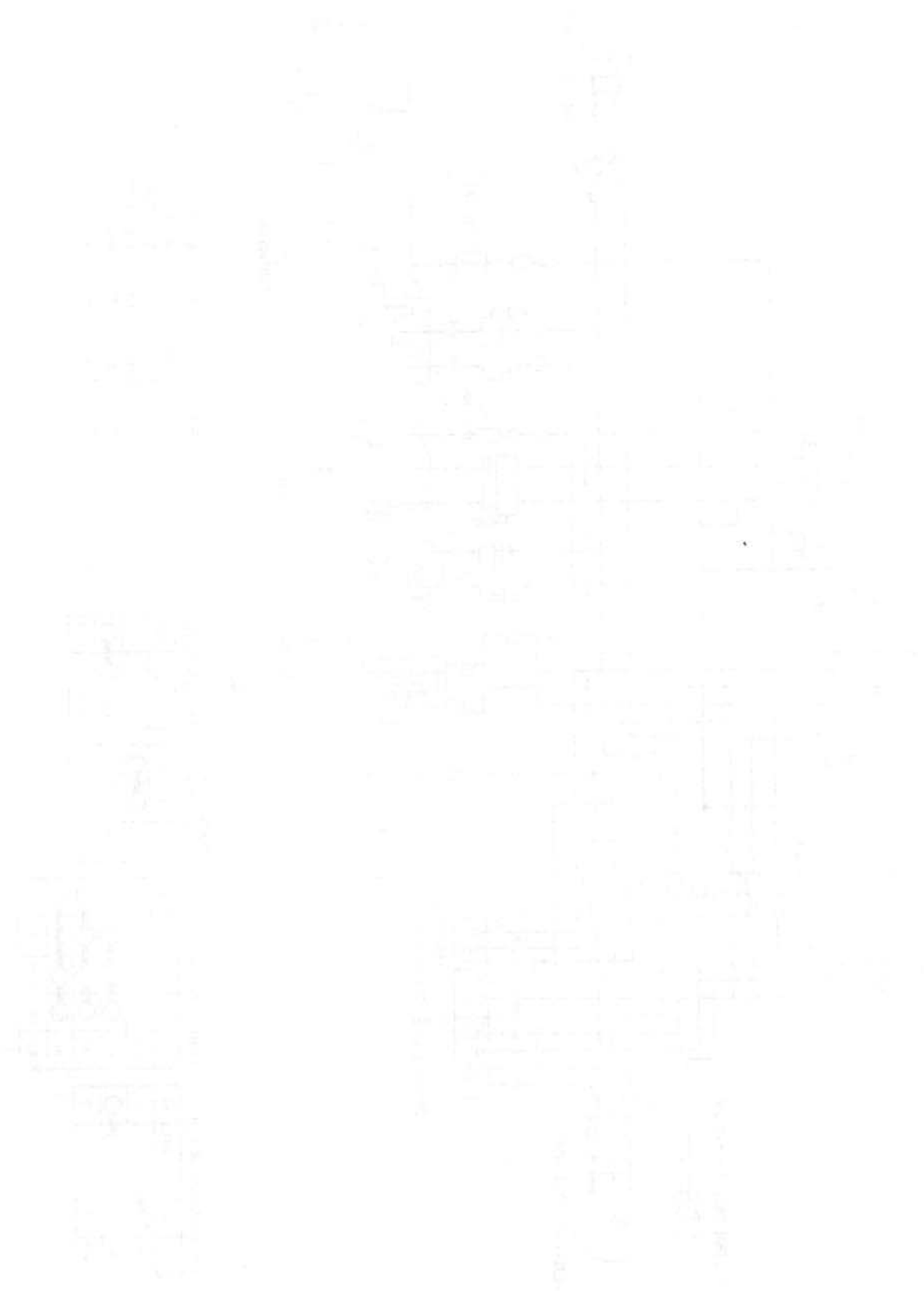

19. TROUBLESHOOTING

ENGINE DOES NOT START OR IS HARD TO START	19-1
ENGINE LACKS POWER	19-2
POOR PERFORMANCE AT LOW AND IDLE SPEEDS	19-3
POOR PERFORMANCE AT HIGH SPEEDS	19-4
POOR HANDLING	19-4

ENGINE DOES NOT START OR IS HARD TO START

1. Check if fuel is getting to carburetor.

GETTING TO CARBURETOR

2. Try spark test.

GOOD SPARK

3. Test cylinder compression.

COMPRESSION NORMAL

4. Start by following normal starting procedure.

ENGINE DOES NOT FIRE

5. Remove spark plug.

DRY

6. Start with choke applied.

NOT GETTING TO CARBURETOR

Probable Cause:

- (1) No fuel in fuel tank
- (2) Clogged fuel tube or fuel filter
- (3) Clogged float valve
- (4) Clogged fuel tank cap breather hole

WEAK OR NO SPARK

- (1) Faulty spark plug
- (2) Fouled spark plug
- (3) Faulty CDI unit
- (4) Broken or shorted high tension wire
- (5) Faulty alternator
- (6) Broken or shorted ignition coil
- (7) Faulty pulse generator
- (8) Poorly connected, broken or shorted wires
- (9) Pulse generator rotor gap incorrect
- (10) Faulty ignition switch

LOW COMPRESSION

- (1) Low battery charge
- (2) Valve clearance too small
- (3) Valve stuck open
- (4) Worn cylinder and piston rings
- (5) Damaged cylinder head gasket
- (6) Seized valve
- (7) Improper valve timing

ENGINE FIRES BUT SOON STOPS

- (1) Choke excessively open
- (2) Carburetor pilot screw excessively closed
- (3) Air leaking past carburetor insulator
- (4) Improper ignition timing (CDI unit or pulse generator faulty)

WET PLUG

- (1) Carburetor flooded
- (2) Carburetor choke excessively closed
- (3) Throttle valve excessively open
- (4) Air cleaner dirty

ENGINE LACKS POWER

1. Raise wheels off the ground and spin by hand.

WHEEL SPINS FREELY

2. Check tire pressure with tire gauge.

PRESSURE NORMAL

3. Try rapid acceleration from low to second.

ENGINE SPEED DECREASES WHEN CLUTCH IS RELEASED

4. Lightly accelerate engine.

ENGINE SPEED INCREASES

5. Check ignition timing.

CORRECT

6. Check valve clearance.

CORRECT

7. Test cylinder compression using a compression gauge.

NORMAL

8. Check carburetor for clogging.

NOT CLOGGED

9. Remove spark plug.

NOT FOULED OR DISCOLORED

Probable Cause:

WHEEL DOES NOT SPIN FREELY

- (1) Brake dragging
- (2) Worn or damaged wheel bearing
- (3) Wheel bearing needs lubrication
- (4) Drive chain too tight

PRESSURE TOO LOW

- (1) Punctured tire
- (2) Faulty tire valve

ENGINE SPEED DOES NOT CHANGE WHEN CLUTCH IS RELEASED

- (1) Clutch slipping
- (2) Worn clutch disc/plate
- (3) Warped clutch disc/plate

ENGINE SPEED DOES NOT INCREASE SUFFICIENTLY

- (1) Carburetor choke closed
- (2) Clogged air cleaner
- (3) Restricted fuel flow vent
- (4) Clogged fuel tank breather tube
- (5) Clogged muffler

INCORRECT

- (1) Faulty CDI unit
- (2) Faulty pulse generator
- (3) Faulty ignition advancer

INCORRECT

- (1) Improper valve adjustment
- (2) Worn valve seat

TOO LOW

- (1) Valve stuck open
- (2) Worn cylinder and piston rings
- (3) Leaking head gasket
- (4) Improper valve timing

CLOGGED

- (1) Carburetor not serviced frequently enough

FOULED OR DISCOLORED

- (1) Plug not serviced frequently enough
- (2) Use of plug with improper heat range

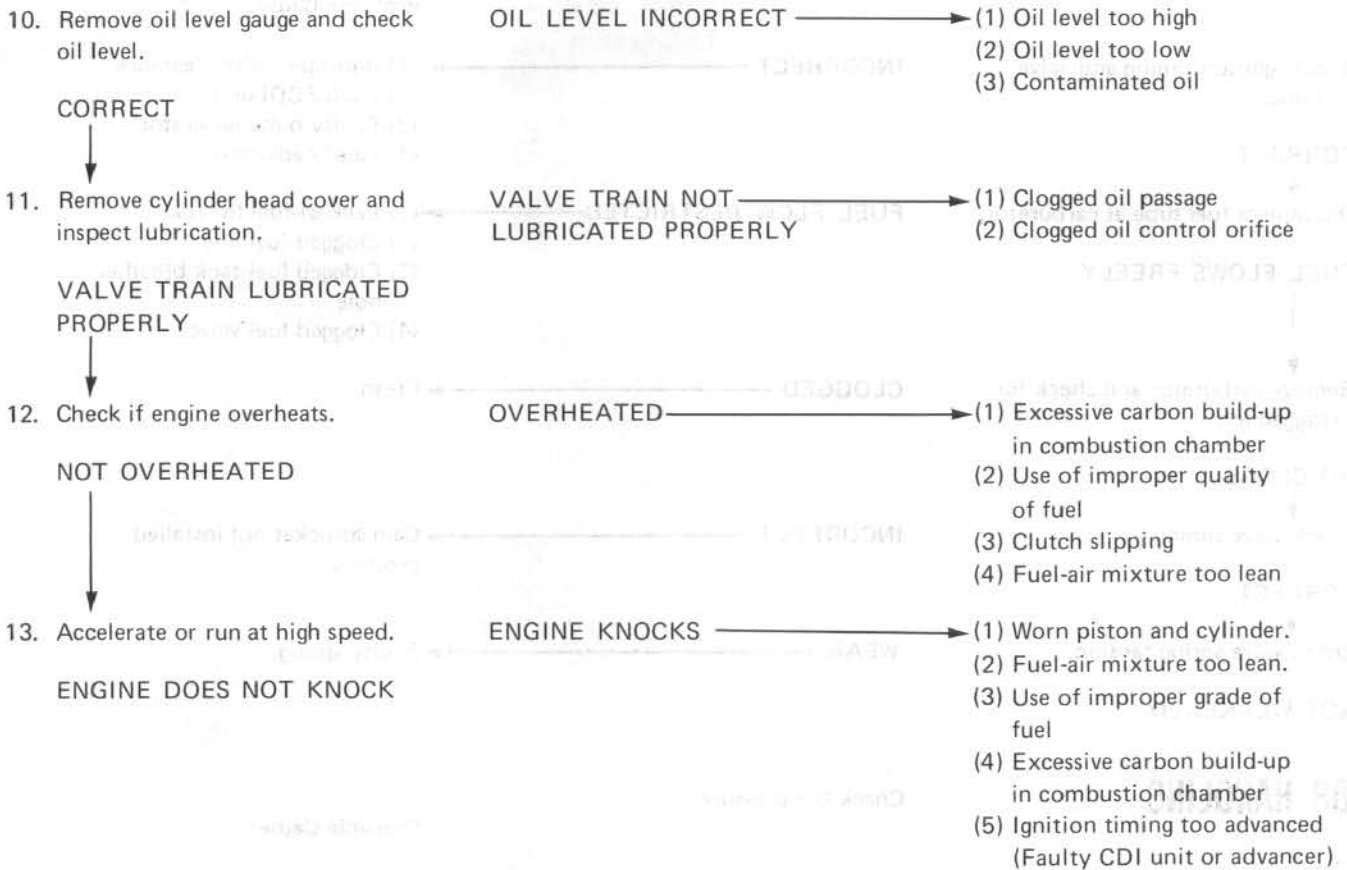

POOR PERFORMANCE AT LOW AND IDLE SPEEDS

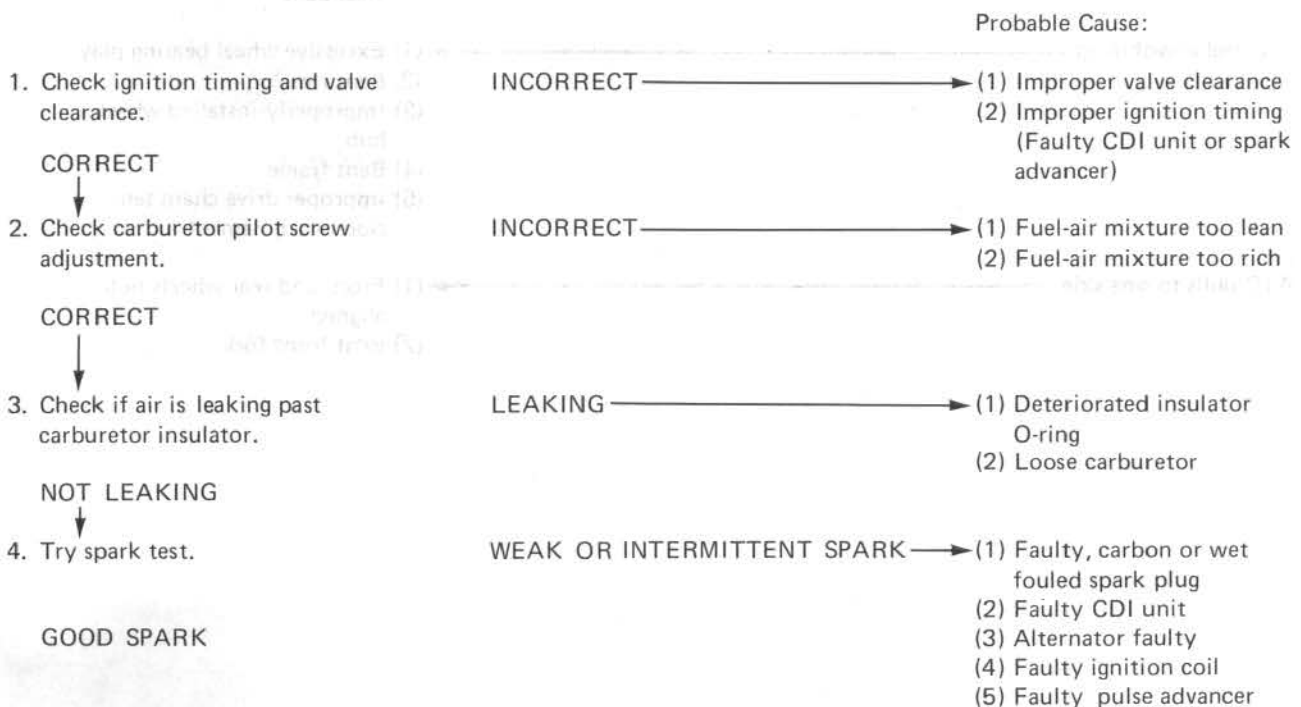

POOR PERFORMANCE AT HIGH SPEEDS

1. Check ignition timing and valve clearance.

CORRECT

2. Disconnect fuel tube at carburetor.

FUEL FLOWS FREELY

3. Remove carburetor and check for a clogged jet.

NO CLOGS

4. Check valve timing.

CORRECT

5. Check valve spring tension.

NOT WEAKENED

INCORRECT

FUEL FLOW RESTRICTED

CLOGGED

INCORRECT

WEAK

Probable Cause:

- (1) Improper valve clearance
- (2) Faulty CDI unit
- (3) Faulty pulse generator
- (4) Faulty advancer

- (1) Lack of fuel in tank
- (2) Clogged fuel line
- (3) Clogged fuel tank breather hole
- (4) Clogged fuel valve

Clean

Cam sprocket not installed properly

Faulty spring

POOR HANDLING

Check tire pressure

Probable Cause:

1. If steering is heavy.

- (1) Steering head adjuster too tight
- (2) Damaged steering cones or steel balls

2. If either wheel is wobbling.

- (1) Excessive wheel bearing play
- (2) Bent rim
- (3) Improperly installed wheel hub
- (4) Bent frame
- (5) Improper drive chain tension or adjustment

3. If the ATC pulls to one side

- (1) Front and rear wheels not aligned
- (2) Bent front fork

MEMO



SERVICE BULLETIN

AMERICAN HONDA MOTOR CO., INC. MOTORCYCLE SERVICE DEPARTMENT

1984—1985 ATC125M NEW CDI UNIT

Engine overrevving can severely damage valves and cylinder heads. Installing a new-type CDI unit will help to prevent damage caused by overrevving.

AFFECTED UNITS:

- 1984 ATC125M — All
- 1985 ATC125M — Frame # 100001 to 138210

MODIFICATION PROCEDURE

1. Install the CDI unit according to the procedure in the ATC125M Shop Manual.
2. Punch an "X" mark below the engine number.

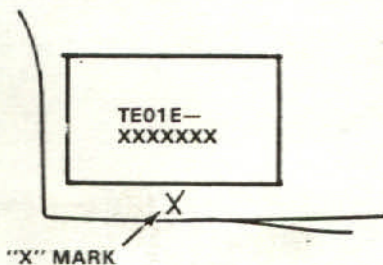

PARTS INFORMATION

- Ignitor unit assembly (CDI) — H/C 1986611

NOTE: This assembly consists of the CDI unit and its rubber mount.

WARRANTY INFORMATION

The normal warranty applies. If you feel that goodwill consideration is appropriate, contact your DSM for approval before you install the new unit.

Defect code: 074
 Failed Honda code: 150802
 Labor operation number: 615120
 Flat rate time: 0.1 hour.
 Treatment code: 1

AMERICAN HONDA MOTOR CO., INC.
SERVICE DEPARTMENT

ROUTING:

COPY 1
COPY 2

GENERAL MANAGER
 SERVICE MANAGER

SALES DEPT.
 MECHANICS

OFFICE FILE
 SHOP MANUAL



SERVICE BULLETIN

AMERICAN HONDA MOTOR CO., INC. MOTORCYCLE SERVICE DEPARTMENT

1984 - 1985 ATC125M DIFFICULT SHIFTING

Over a period of time, shifting gears on some of the affected units listed below may require increased effort.

Replacing the shift drum stopper arm and stopper plate with the parts listed in this bulletin will improve shifting performance.

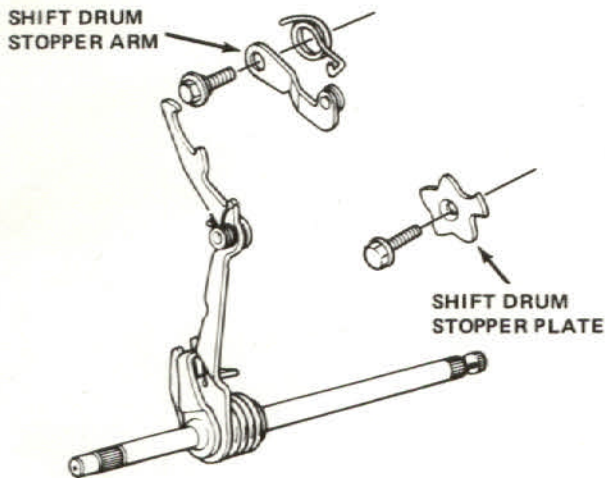

AFFECTED UNITS

1984-1985 ATC125M - All

PROCEDURE

1. Replace the Shift Drum Stopper Arm and Stopper Plate with the parts listed in this bulletin according to the procedures in the Shop Manual.

NOTE: Apply Honda Anaerobic Thread Lock, or an equivalent, to the threads of the Shift Drum Stopper Plate bolt before reinstalling it.

2. For future identification, make a center punch mark on the crankcase just to the right of the engine number.

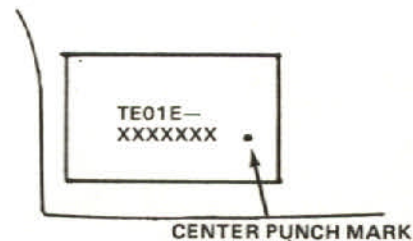

PARTS INFORMATION

- Shift Drum Stopper Arm
H/C 2077675 P/N 24430-943-000
- Shift Drum Stopper Plate
H/C 2280139 P/N 24425-943-000

NOTE: These parts must be replaced as a set.

WARRANTY INFORMATION

The normal warranty applies. If you feel goodwill consideration is appropriate, contact your DSM for approval before starting the job.

Defect Code: 031
Failed Honda Code: 1252444
Labor Operation Number: 210125
Flat Rate Time: 0.6 hr.
Treatment Code: 1

ROUTING:

COPY 1
COPY 2

- | | | |
|--|--------------------------------------|--------------------------------------|
| <input type="checkbox"/> GENERAL MANAGER | <input type="checkbox"/> SALES DEPT. | <input type="checkbox"/> OFFICE FILE |
| <input type="checkbox"/> SERVICE MANAGER | <input type="checkbox"/> MECHANICS | <input type="checkbox"/> SHOP MANUAL |