

Official

HONDA

SHOP MANUAL

ATC200X

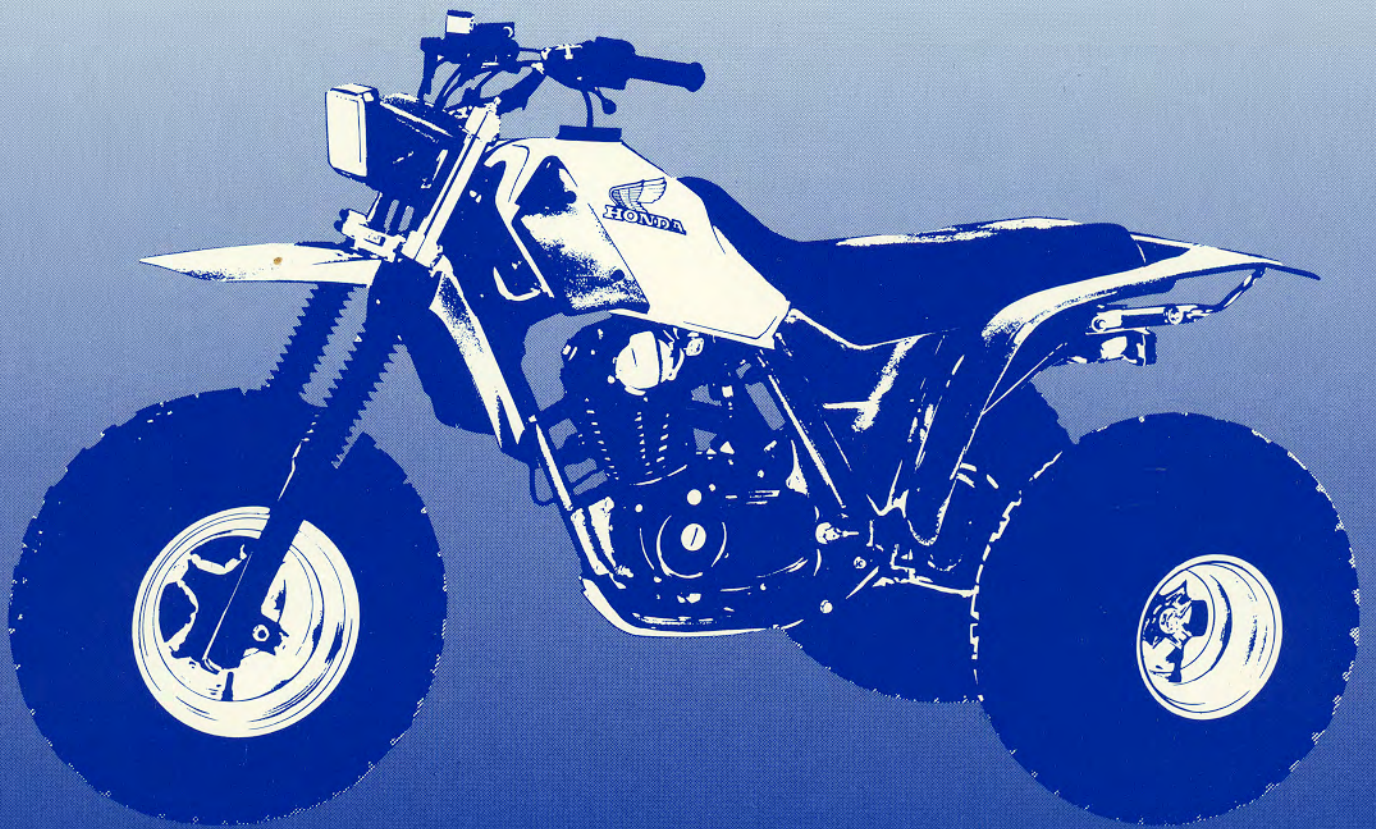

'83-'85

Thank you for your patronage.

This CD was purchased from @home backup. If it was purchased or obtained by any other means, you have illegally obtained this CD and are in violation of its copyrights.

Report copyright violations to: @home backup
Attn: Manual Backups
2902 Grasmere St.
Garland, TX 75040

Unauthorized duplication or distribution is strictly prohibited.

IMPORTANT SAFETY NOTICE

 **WARNING** *Indicates a strong possibility of severe personal injury or loss of life if instructions are not followed.*

CAUTION: *Indicates a possibility of personal injury or equipment damage if instructions are not followed.*

NOTE: Gives helpful information.

Detailed descriptions of standard workshop procedures, safety principles and service operations are not included. It is important to note that this manual contains *some* warnings and cautions against some specific service methods which could cause **PERSONAL INJURY** to service personnel or could damage a vehicle or render it unsafe. Please understand that those warnings could not cover all conceivable ways in which service, whether or not recommended by Honda might be done or of the possibly hazardous consequences of each conceivable way, nor could Honda investigate all such ways. Anyone using service procedures or tools, whether or not recommended by Honda *must satisfy himself thoroughly* that neither personal safety nor vehicle safety will be jeopardized by the service method or tools selected.

HOW TO USE THIS MANUAL

Section 1 through 3 apply to the whole motorcycle, while sections 4 through 16 describe parts of the motorcycle, grouped according to location.

Find the section you want on this page, then turn to the table of contents on page 1 of that section.

Most sections start with an assembly or system illustration and all the required specifications, torque values, general instructions, tools and troubleshooting for the section. The subsequent pages give detailed procedures.

If you don't know what the source of the trouble is, go to section 17.

All information, illustrations, directions and specifications included in this publication are based on the latest product information available at the time of approval for printing. Honda Motor CO., LTD. reserves the right to make changes at any time without notice and without incurring any obligation whatever. No part of this publication may be reproduced without written permission.

HONDA MOTOR CO., LTD.
Service Publications Office

CONTENTS

	GENERAL INFORMATION	1
	LUBRICATION	2
	MAINTENANCE	3
ENGINE	FUEL SYSTEM	4
	ENGINE REMOVAL/INSTALLATION	5
	CYLINDER HEAD/VALVES	6
	CYLINDER/PISTON	7
	CLUTCH/OIL PUMP/ GEARSHIFT LINKAGE	8
	ALTERNATOR	9
	TRANSMISSION/CRANKSHAFT/ KICK STARTER	10
	CHASSIS	FRONT WHEEL/SUSPENSION/ STEERING
REAR WHEEL/DRIVE MECHANISM		12
REAR SUSPENSION		13
BRAKE MECHANISM		14
REAR FENDER/EXHAUST PIPE		15
ELECTRICAL SYSTEM		16
	TROUBLESHOOTING	17

1. GENERAL INFORMATION

GENERAL SAFETY	1-1
SERVICE RULES	1-1
MODEL IDENTIFICATION	1-2
SPECIFICATIONS	1-3
TORQUE VALUES	1-5
TOOLS	1-6
CABLE & HARNESS ROUTING	1-7

GENERAL SAFETY

WARNING

If the engine must be running to do some work, make sure that area is well-ventilated. Never run the engine in a closed area. The exhaust contains poisonous carbon monoxide gas.

WARNING

Gasoline is extremely flammable and is explosive under certain conditions. Do not smoke or allow flames or sparks in your work area.

SERVICE RULES

1. Use genuine HONDA or HONDA-recommended parts and lubricants or their equivalent. Parts that don't meet HONDA's design specifications may damage the motorcycle.
2. Use the special tools designed for this product to avoid damage and incorrect assembly.
3. Use only metric tools when servicing this motorcycle. Metric bolts, nuts, and screws are not interchangeable with English fasteners.
4. Install new gaskets, O-rings, cotter pins, lock plates, etc. when reassembling.
5. When torquing bolts or nuts, begin with the larger-diameter or inner bolt first. Then tighten to the specified torque diagonally in 2-3 steps, unless a particular sequence is specified.
6. Clean parts in non-flammable or high flash point solvent upon disassembly.
7. Lubricate any sliding surfaces before reassembly.
8. After reassembly, check all parts for proper installation and operation.

GENERAL INFORMATION

MODEL IDENTIFICATION

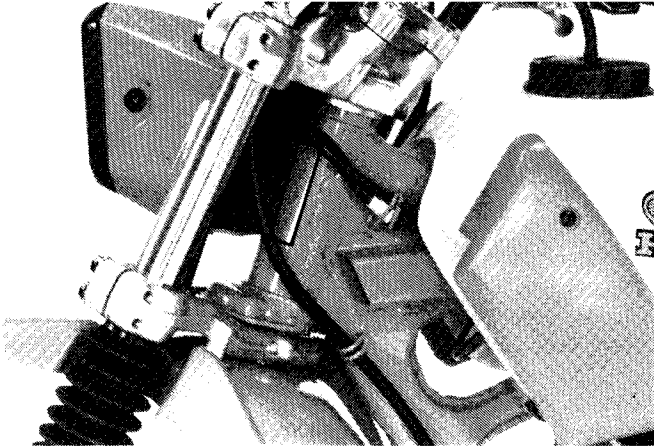
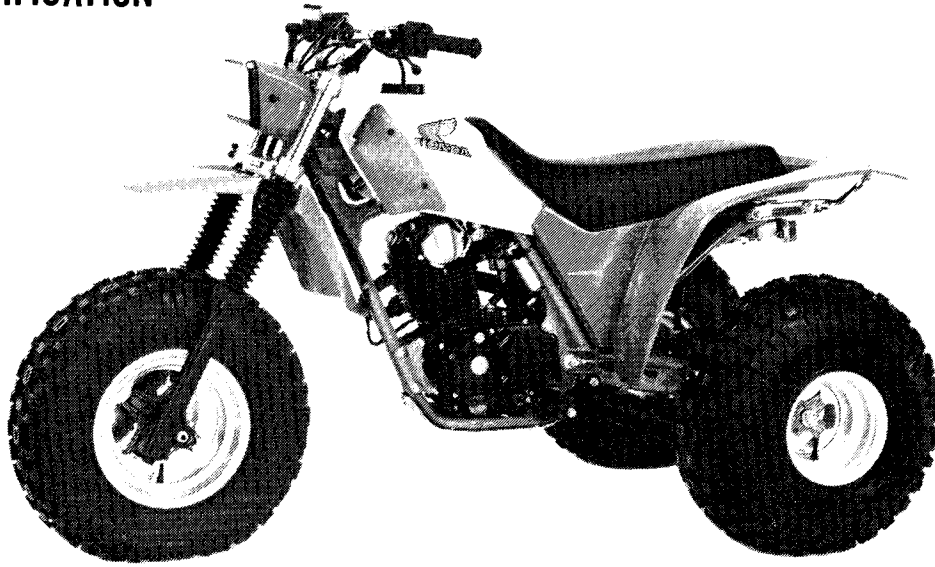

The frame serial number is stamped on the steering head lift side.

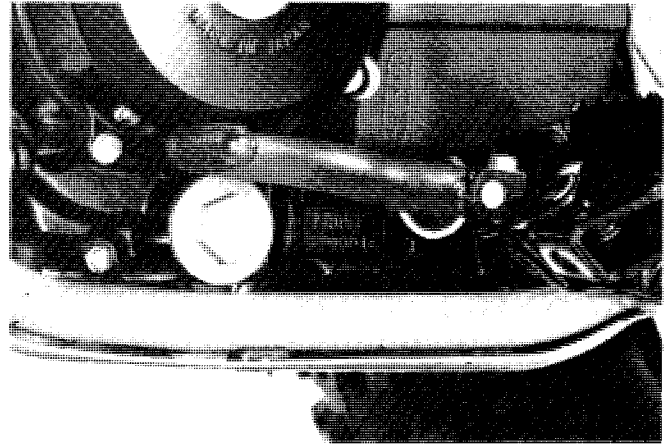

The engine serial number is stamped on the crankcase lower right side.

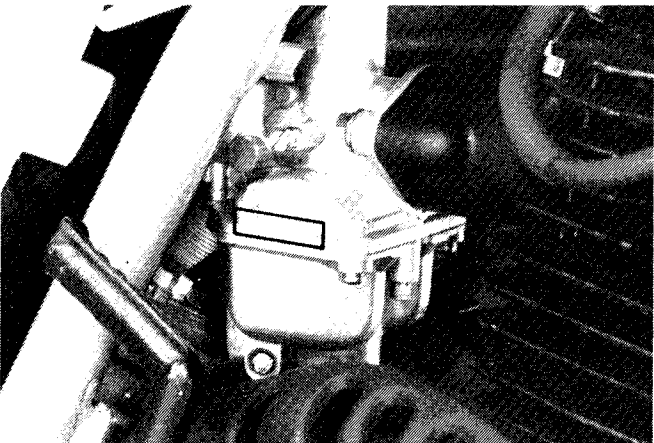

The carburetor identification number is on the carburetor body right side.

SPECIFICATIONS

<p>DIMENSIONS</p>	<p>Overall length Overall width Overall height Wheel base Seat height Foot peg height Ground clearance Dry weight</p>	<p>1,850 mm (72.8 in) 1,050 mm (41.3 in) 1,040 mm (40.9 in) 1,210 mm (47.6 in) 705 mm (27.8 in) 290 mm (11.4 in) 125 mm (4.9 in) 128.0 kg (282.2 lb)</p>								
<p>FRAME</p>	<p>Type Front suspension, travel Rear suspension, travel Front tire size, pressure Rear tire size, pressure Front brake Rear brake Fuel capacity Fuel reserve capacity Caster Trail Front fork oil capacity</p>	<p>Semi-double cradle Telescopic air fork, 185 mm (7.3 in) Swingarm, 170 mm (6.7 in) 23.5 x 8—11, 23 kPa (0.23 kg/cm², 3.3 psi) 22 x 11—8, 17 kPa (0.17 kg/cm², 2.4 psi) Single disc Single disc 9.7 lit (2.56 US gal., 2.14 Imp gal) 1.4 lit (0.37 US gal., 0.31 Imp gal) 22° 35 mm (1.38 in)</p> <table border="1" data-bbox="966 907 1380 1045"> <tr> <td>1983</td> <td>209 cc (7.1 US oz, 5.9 Imp oz)</td> </tr> <tr> <td>After 1983</td> <td>214 cc (7.2 US oz, 6.0 Imp oz)</td> </tr> </table>	1983	209 cc (7.1 US oz, 5.9 Imp oz)	After 1983	214 cc (7.2 US oz, 6.0 Imp oz)				
1983	209 cc (7.1 US oz, 5.9 Imp oz)									
After 1983	214 cc (7.2 US oz, 6.0 Imp oz)									
<p>ENGINE</p>	<p>Type Cylinder arrangement Bore x stroke Displacement Compression ratio Valve train Maximum horsepower Maximum torque Oil capacity Lubrication system Air filtration system Cylinder compression Intake valve OPEN CLOSES Exhaust valve OPEN CLOSES Valve clearance IN EX</p>	<p>Gasoline, air-cooled 4-stroke Single cylinder inclined 15° 65.0 x 57.8 mm (2.56 x 2.28 in) 191.8 cm³ (11.70 cu-in) 9.6 : 1 Overhead camshaft chain driven 18 ps/8,000 rpm 1.7 kg-m/6,000 rpm 1.2 lit (1.3 US qt, 1.1 Imp qt) 1.0 lit (1.1 US qt, 0.9 Imp qt) Forced pressure and wet sump Oiled polyurethane foam 1,128 kPa (11.5 kg/cm², 164 psi) 5° BTDC } 35° ABDC } at 1.0 mm lift 35° BBDC } 5° ATDC }</p> <p>0.08 mm (0.003 in) (Cold) 0.08 mm (0.003 in) (Cold)</p>								
<p>CARBURETOR</p>	<p>Type Main jet Pilot screw opening Float level Idle speed Bore</p>	<p>Piston valve</p> <table border="1" data-bbox="966 1696 1404 1768"> <tr> <td>1983</td> <td># 110</td> </tr> <tr> <td>After 1983</td> <td># 108</td> </tr> </table> <table border="1" data-bbox="966 1774 1404 1837"> <tr> <td>1983</td> <td>1—3/4 turn out</td> </tr> <tr> <td>After 1983</td> <td>1—1/2 turn out</td> </tr> </table> <p>14.0 mm (0.55 in) 1,300 ± 100 rpm 24 mm (0.94 in)</p>	1983	# 110	After 1983	# 108	1983	1—3/4 turn out	After 1983	1—1/2 turn out
1983	# 110									
After 1983	# 108									
1983	1—3/4 turn out									
After 1983	1—1/2 turn out									

GENERAL INFORMATION

<p>DRIVE TRAIN</p>	<p>Clutch Transmission Primary reduction Gear ratio I Gear ratio II Gear ratio III Gear ratio IV Gear ratio V Final reduction Gearshift pattern Drive chain size/links</p>	<p>Wet multi-plate 5-speed constant mesh 3.333 2.769 1.941 1.450 1.130 0.923 3.333 Left foot operated return system, 1-N-2-3-4-5 520/88</p>								
<p>ELECTRICAL</p>	<p>Ignition system Ignition timing initial Full advance Alternator Spark plug Spark plug gap Headlight Tail light</p>	<p>CDI</p> <table border="1" data-bbox="919 653 1446 730"> <tr> <td>1983</td> <td>$10^{\circ} \pm 2^{\circ}$ BTDC at idle</td> </tr> <tr> <td>After 1983</td> <td>$5^{\circ} \pm 2^{\circ}$ BTDC at idle</td> </tr> </table> <table border="1" data-bbox="919 747 1446 825"> <tr> <td>1983</td> <td>$30^{\circ} \pm 2^{\circ}$ BTDC 3,350 \pm 150 rpm</td> </tr> <tr> <td>After 1983</td> <td>$30^{\circ} \pm 2^{\circ}$ BTDC 3,150 \pm 150 rpm</td> </tr> </table> <p>68W/5,000 rpm NGK DR8ES-L ND X24ESR-U CHAMPION RA6YC 0.6–0.7 mm (0.024–0.028 in) 12V–60/60W 12V-5W</p>	1983	$10^{\circ} \pm 2^{\circ}$ BTDC at idle	After 1983	$5^{\circ} \pm 2^{\circ}$ BTDC at idle	1983	$30^{\circ} \pm 2^{\circ}$ BTDC 3,350 \pm 150 rpm	After 1983	$30^{\circ} \pm 2^{\circ}$ BTDC 3,150 \pm 150 rpm
1983	$10^{\circ} \pm 2^{\circ}$ BTDC at idle									
After 1983	$5^{\circ} \pm 2^{\circ}$ BTDC at idle									
1983	$30^{\circ} \pm 2^{\circ}$ BTDC 3,350 \pm 150 rpm									
After 1983	$30^{\circ} \pm 2^{\circ}$ BTDC 3,150 \pm 150 rpm									

TORQUE VALUES

ENGINE

ITEM	Q'TY	THREAD DIA. (mm)	TORQUE		
			N·m	kg·m	ft·lb
Cylinder head nut	4	8	28-30	2.8-3.0	20-22
Cylinder head cover	4	6	8-12	0.8-1.2	6-9
Flywheel bolt	1	8	45-55	4.5-5.5	33-40
Clutch lock nut	1	16	40-50	4.0-5.0	29-36
Oil filter rotor lock nut	1	16	40-50	4.0-5.0	29-36
Oil filter screen cap	1	36	10-20	1.0-2.0	7-14

FRAME

ITEM	Q'TY	THREAD DIA. (mm)	TORQUE N·m (kg·m, ft·lb)
Steering stem nut	1	24	70-100 (7.0-10.0, 51-72)
Steering top thread nut	1	26	5.5-6.5 (0.55-0.65, 4.0-4.7)
Swingarm pivot bolt	1	14	70-110 (7.0-11.0, 51-80)
Rear wheel hub nuts	2	18	80-100 (8.0-10.0, 58-72)
Rear axle nut Inner	1	32	35-45 (3.5-4.5, 25-33)
Outer	1	32	120-140 (12.0-14.0, 87-101)
Front engine hanger plate	2	8	23-27 (2.3-2.7, 17-20)
Front engine hanger bolts	2	8	23-27 (2.3-2.7, 17-20)
Bottom engine mounting bolt	1	10	45-53 (4.5-5.3, 32-38)
Lower engine hanger bolt	1	10	40-48 (4.0-4.8, 29-35)
Upper engine hanger bolt	1	8	23-27 (2.3-2.7, 17-20)
Upper engine hanger plate	2	8	23-27 (2.3-2.7, 17-20)
Carburetor inlet pipe nuts	2	6	6-9 (0.6-0.9, 4-7)

Torque specifications listed above are for the most important tightening points. If a torque specification is not listed, follow the standards given below.

STANDARD TORQUE VALUES

TYPE	TORQUE N·m (kg·m, ft·lb)	TYPE	TORQUE N·m (kg·m, ft·lb)
5 mm bolt, nut	4.5-6.0 (0.45-0.6, 3.3-4.3)	5 mm screw	3.5-5.0 (0.35-0.5, 2.5-3.6)
6 mm bolt, nut	8-12 (0.8-1.2, 6-9)	6 mm screw	7-11 (0.7-1.1, 5-8)
8 mm bolt, nut	18-25 (1.8-2.5, 13-18)	6 mm flange bolt, nut	10-14 (1.0-1.4, 7-10)
10 mm bolt, nut	30-40 (3.0-4.0, 22-29)	8 mm flange bolt, nut	24-30 (2.4-3.0, 17-22)
12 mm bolt, nut	50-60 (5.0-6.0, 36-43)	10 mm flange bolt, nut	30-40 (3.0-4.0, 22-29)

GENERAL INFORMATION

TOOLS

SPECIAL

DESCRIPTION	NUMBER	ALTERNATIVE TOOL	NUMBER	REF. SECT.
Valve Guide Reamer	07984-0980000	Steering Stem Driver Steering Stem Driver and Steering Stem Driver Attachment (U.S.A. Only) Not Available in U.S.A.	07946-3710601 or 07946-3710600	6-12
Clutch Holder	07923-1070001			8-5, 8-9
Steering Stem Socket	07916-3710100			11-26
Race Remover	07953-3330000			11-28
Steering Stem Driver	07946-4300001			11-29
Lock Nut Wrench with handle, 41 mm	07916-9580300	Equivalent Tools Commercially Available in U.S.A.	NG-HT-54	12-4, 12-5
Lock Nut Wrench, 41 mm	07916-9580400			12-4, 12-5
Lock Nut Spanner, 41 mm	07916-9580200			11-19, 11-23
Hex. Wrench, 6 mm	07917-3230000	Equivalent Tool Commercially Available in U.S.A.	M967X-038-XXXXX	13-11
Bearing Remover, 20 mm	07936-3710600	Swingarm Bushing/ Bearing Remover (U.S.A. Only)		13-11
Remover Handle	07936-3710100			13-11
Remover Weight	07741-0010201	(U.S.A. Only)		14-8, 14-18
Snap Ring Pliers	07914-3230001			11-13
Tire Disassembling Tool	GN-AH-958-BBI			(U.S.A. Only)
Tire Bead Breaker	07772-0050000	Not Available in U.S.A.		
(Breaker arm	07772-0050200)			
(Breaker arm compressor)	07772-0050100)			

COMMON

DESCRIPTION	NUMBER	ALTERNATIVE TOOL	NUMBER	REF. SECT.
Valve Adjusting Wrench, 10 x 12 mm	07708-0030200	Equivalent Tools Commercially Available in U.S.A.	07957-3290001 07942-3290100	3-5
Valve Adjuster	07708-0030300			4-9
Float Level Gauge	07401-0010000	6-9, 6-16		
Valve Spring Compressor	07757-0010000	6-11		
Valve Guide Remover, 5.5 mm	07742-0010100	8-5, 8-8, 8-9		
Lock Nut Wrench, 20 x 24 mm	07716-0020100	8-5, 8-8, 8-9		
Extension	07716-0020500	11-26		
Universal Holder	07725-0030000	Equivalent Tool Commercially Available in U.S.A.		8-5, 8-8, 9-3
Rotor Puller	07733-0010000	Rotor Puller		9-3
Attachment, 32 x 35 mm	07746-0010100			10-7, 13-12
Attachment, 42 x 47 mm	07746-0010300		10-7, 11-16	
Attachment, 52 x 55 mm	07746-0010400		10-7	
Pilot, 15 mm	07746-0040300		10-7, 11-6	
Pilot, 20 mm	07746-0040500		10-7, 13-12	
Pilot, 30 mm	07746-0040700		10-7	
Driver	07749-0010000		10-7, 11-16, 13-12	
Fork Seal Driver Body	07747-0010100		Fork Seal Driver	11-23
Attachment (D)	07747-0010500			11-23
Lock Nut Wrench, 30 x 32 mm	07716-0020400	Equivalent Tool Commercially Available in U.S.A.	11-26	
Attachment, 62 x 68 mm	07746-0010500		13-12	
Pilot, 35 mm	07746-0040800		13-12	

OPTIONAL

DESCRIPTION	NUMBER	ALTERNATIVE TOOL	NUMBER	REF. SECT.
Pin Spanner	89201-KA4-810	Equivalent Tools Commercially Available in U.S.A.		13-2
Pin Spanner	89202-KA4-810			13-2
Valve Seat Cutter, 29 mm	07780-0010300			6-13
Valve Seat Cutter, 35 mm	07780-0010400			6-13
Valve Seat Cutter, 30 mm	07780-0014000			6-13
Valve Seat Cutter, 37.5 mm	07780-0014100			6-13
Valve Seat Cutter, 30 mm	07780-0012200			6-13
Valve Seat Cutter, 35 mm	07780-0012300			6-13
Valve Seat Cutter Holder	07781-0010100			6-13

CABLE & HARNESS ROUTING

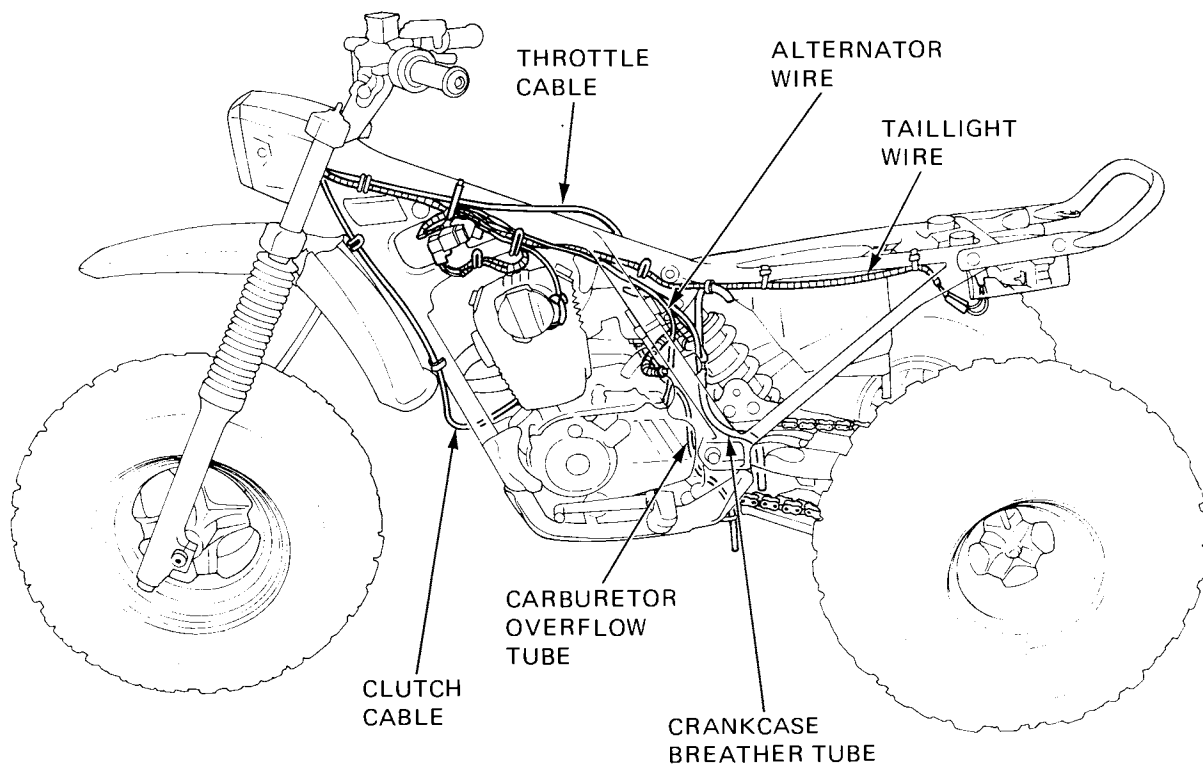
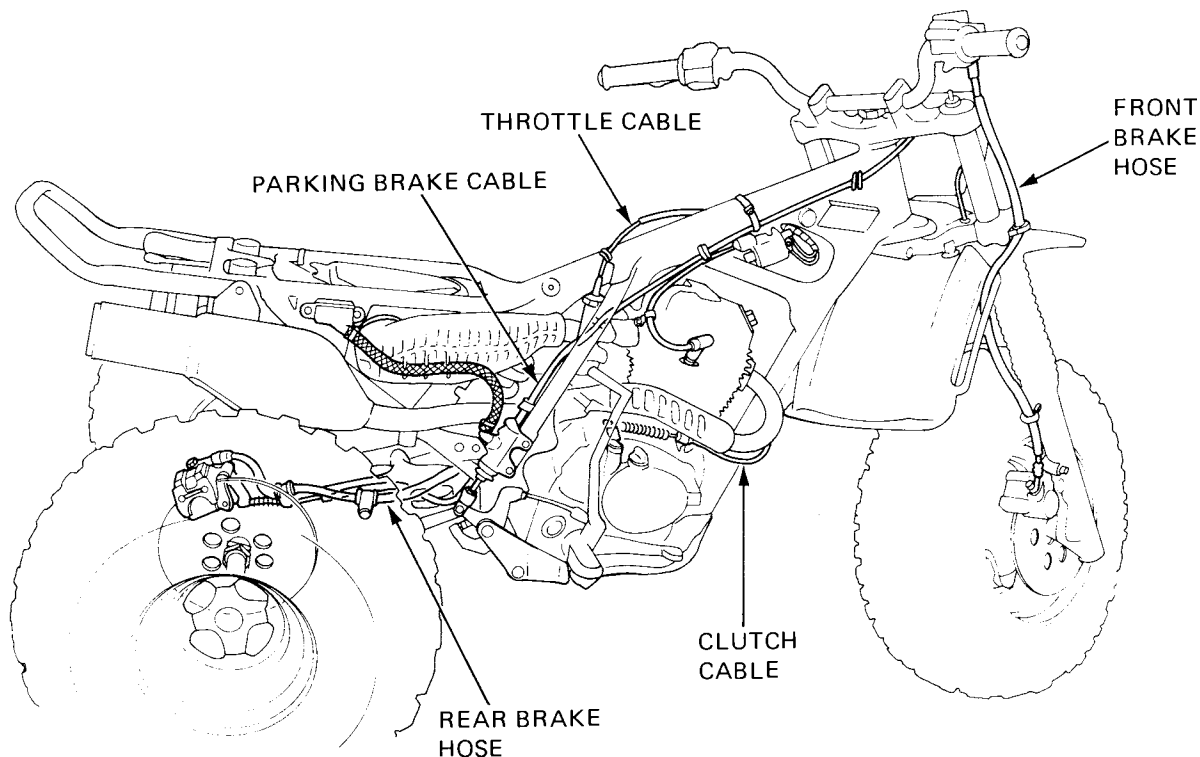

GENERAL INFORMATION

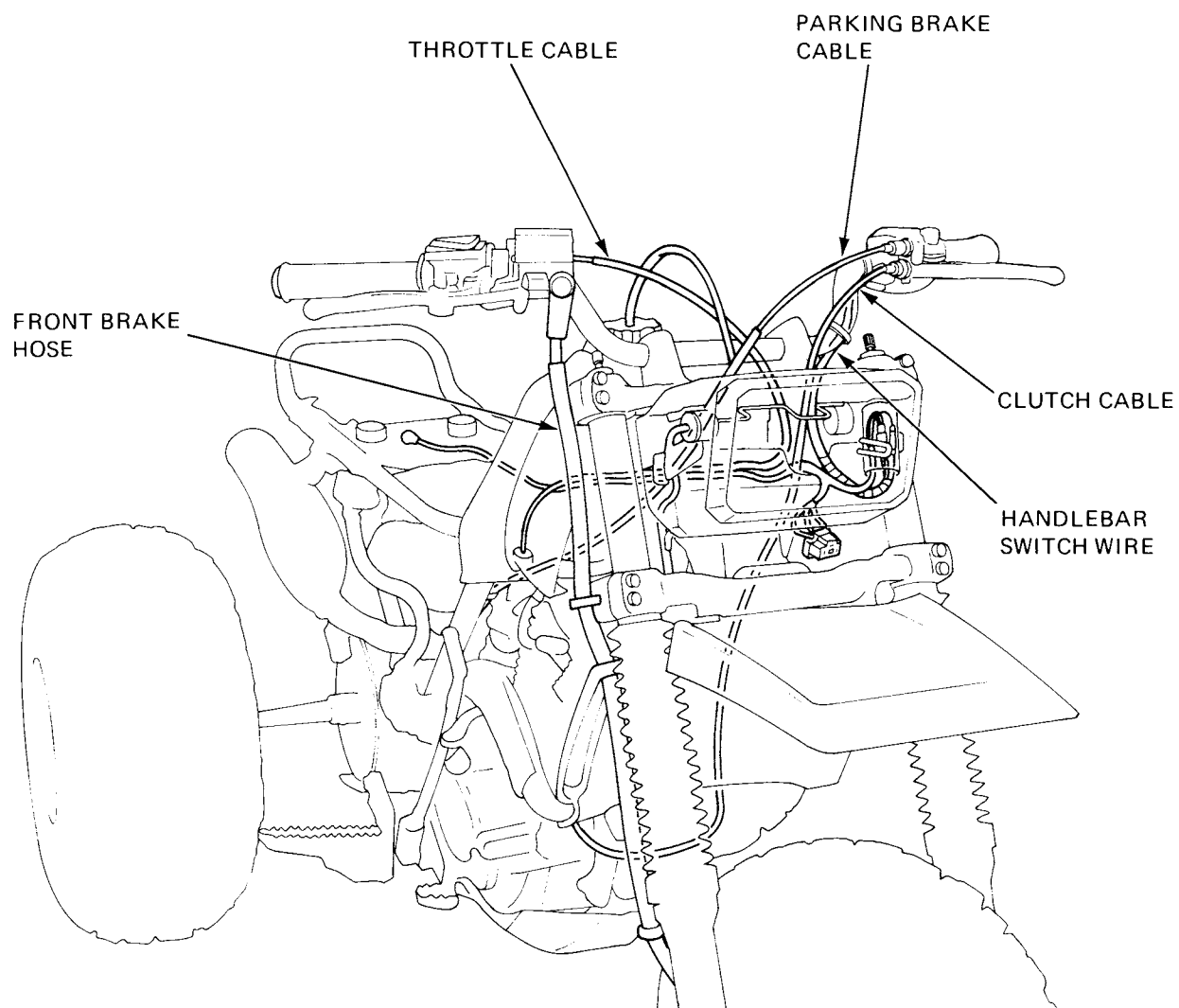

Note the following when routing cables and wire harnesses.

A loose wire, harness or cable can be a safety hazard. After clamping, check each wire to be sure it is secure.

- Do not squeeze wires against the weld or end of its clamp when a weld-on clamp is used.
- Secure wires and wire harnesses to the frame with their respective wire bands at the designated locations. Tighten the bands so that only the insulated surfaces contact the wires or wire harnesses.
- Route harnesses so they are not pulled that or have excessive slack.
- Protect wires and harnesses with electrical tape or tube if they are contact a sharp edge or corner. Clean the attaching surface thoroughly before applying tape.
- Do not use wires or harnesses with a broken insulator. Repair by wrapping them with a protective tape or replace them.
- Route wire harnesses to avoid sharp edges or corners.
- Also avoid the projected ends of bolts and screws.
- Keep wire harnesses away from the exhaust pipes and other hot parts.
- Be sure grommets are seated in their grooves properly.
- After clamping, check each harness to be certain that it is not interfering with any moving or sliding parts.
- After routing, check that the wire harnesses are not twisted or kinked.
- Wire harnesses routed along the handle bars should not be pulled taut, have excessive slack, be pinched, or interfere with adjacent or surrounding parts in all steering positions.

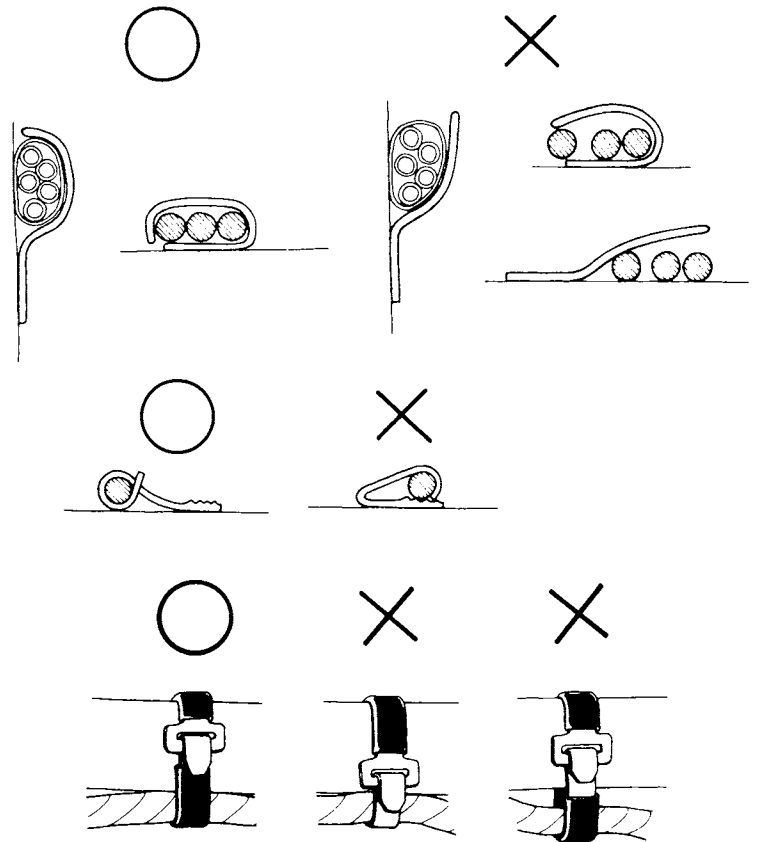

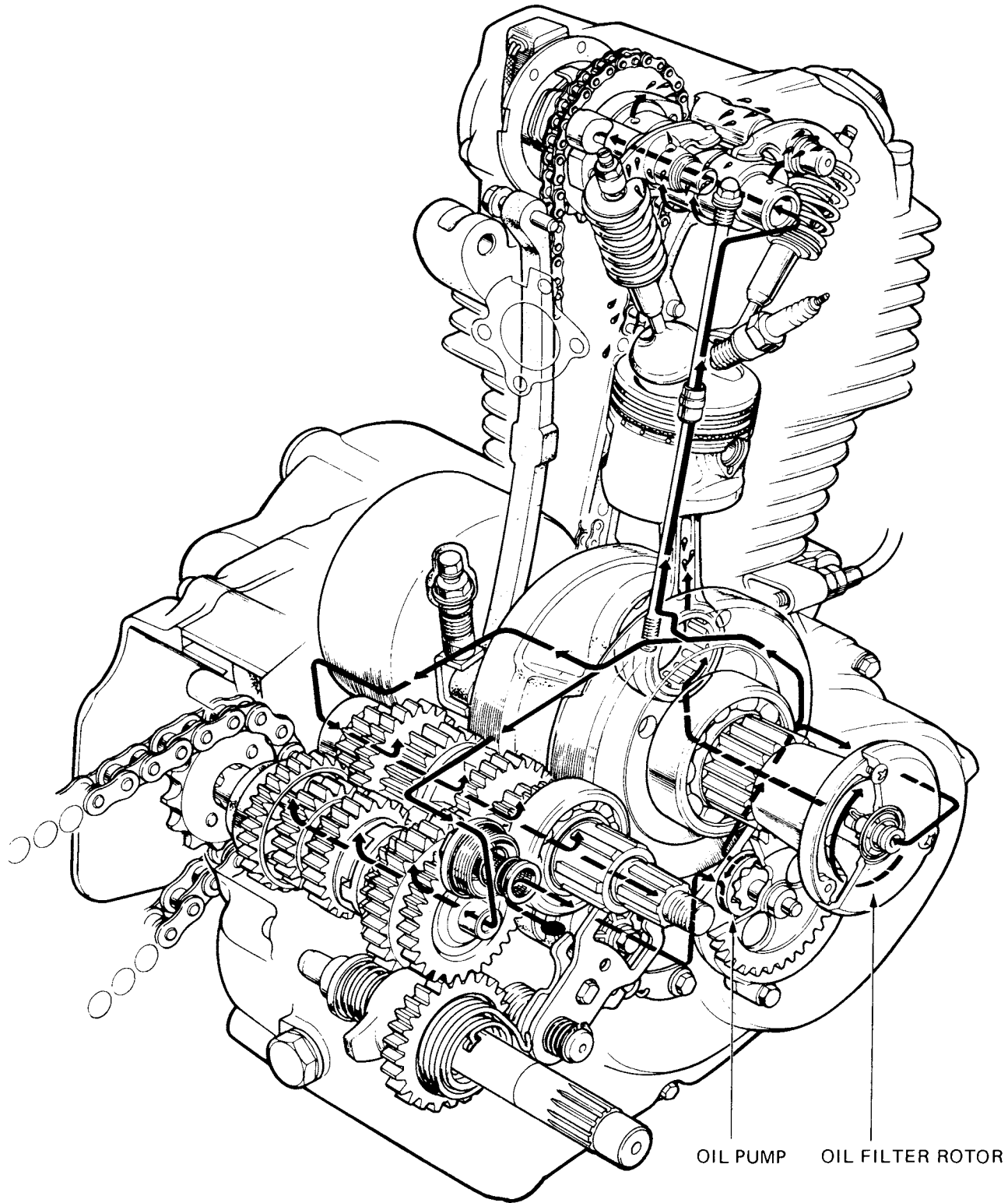

2. LUBRICATION

SERVICE INFORMATION	2-1
TROUBLESHOOTING	2-1
ENGINE OIL LEVEL CHECK	2-2
ENGINE OIL CHANGE AND OIL FILTER SCREEN CLEANING	2-2
OIL FILTER ROTOR CLEANING	2-3
CONTROL CABLE LUBRICATION	2-3
LUBRICATION POINTS	2-4

SERVICE INFORMATION

GENERAL

- This section describes how to inspect and replace the engine oil and clean the oil filter screen.
- Section 8 shows how to service the oil pump.

SPECIFICATIONS

Oil capacity 1.2 lit (1.3 US qt, 1.1 Imp qt) at disassembly
 1.0 lit (1.1 US qt, 0.9 Imp qt) at draining.

Recommended oil: Use HONDA 4-STROKE OIL or equivalent.
 API SERVICE CLASSIFICATION: SE or SF
 VISCOSITY: SAE 10W-40

Other oil viscosities may be used when the average temperature in your riding area is within the indicated range on the chart.

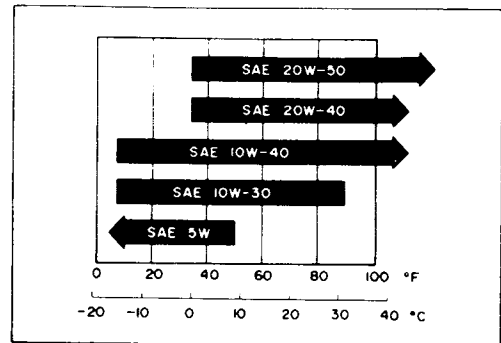

TORQUE VALUE

Oil filter screen cap: 10-20 N·m (1.0-2.0 kg·m, 7-14 ft·lb)

TROUBLESHOOTING

Oil level too low

1. External oil leaks
2. Worn piston rings

Oil consumption

1. Oil not changed often enough
2. Faulty head gasket

LUBRICATION

ENGINE OIL LEVEL CHECK

Place the ATC on level ground. Check the oil level with the oil cap/dipstick. Do not screw in the cap when making this check.

If the oil level is below the lower level mark on the dipstick, fill to the upper level mark with the recommended oil.

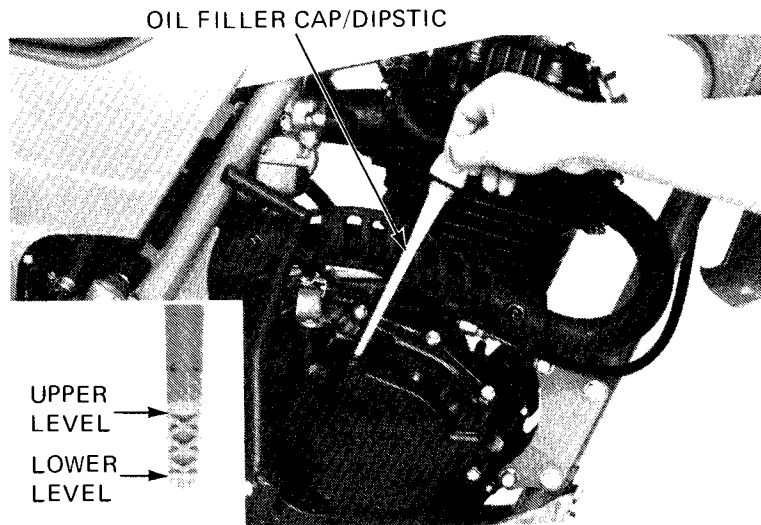

ENGINE OIL CHANGE AND OIL FILTER SCREEN CLEANING

NOTE:

- Drain the oil with the engine warm.
- The oil filter screen and spring will come out when the oil filter screen cap is removed.
- Use 24 mm 6-point socket or wrench to prevent rounding the corners of the screen cap.

Remove the oil filler cap and oil filter screen cap.

Operate the kick starter pedal several times to completely drain any residual oil.
Clean the oil filter screen.

Make sure that the oil filter screen, sealing rubber, screen cap and O-ring are in good condition.

Install the oil filter screen, spring and screen cap.

Fill the crankcase with the recommended oil.

ENGINE OIL CAPACITY:

1.0 liters (1.1 US qt, 0.9 Imp qt) after draining

Install the oil filler cap.

Start the engine and let it idle for 2-3 minutes.

Stop the engine.

With the ATC on level ground, make sure that the oil level is at the upper level mark.

Be sure there are no leaks.

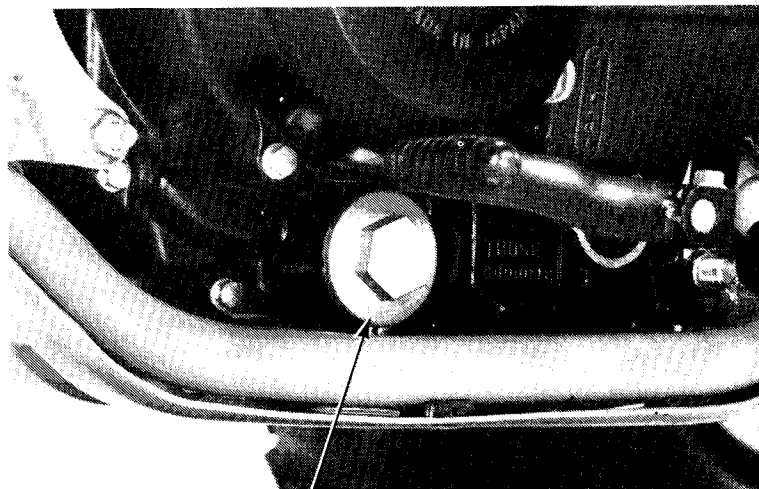

OIL FILTER SCREEN CAP

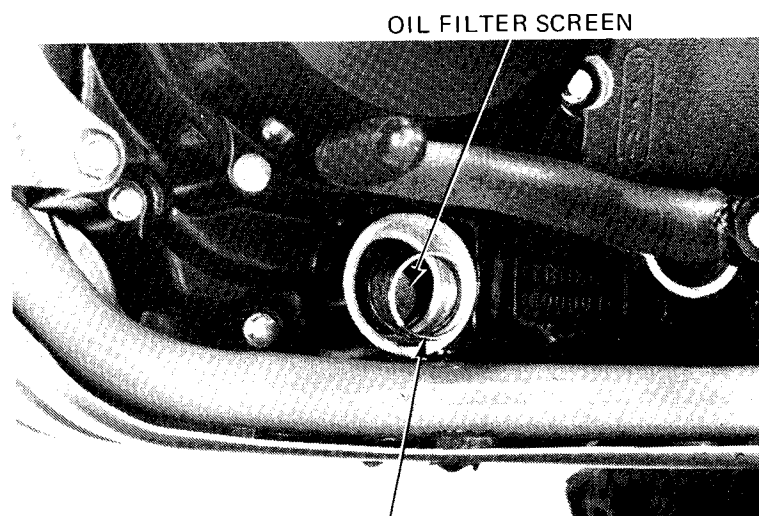

SPRING

OIL FILTER ROTOR CLEANING

NOTE:

Clean the oil filter rotor before adding oil.

Remove the right crankcase cover (page 8-3).

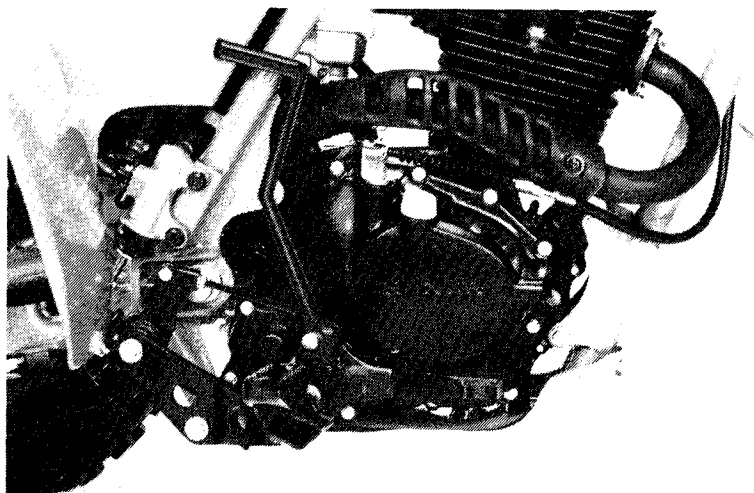

Remove the oil filter rotor cover and clean the rotor.

Make sure that the rotor cover gasket is in good condition and install the oil filter rotor cover.

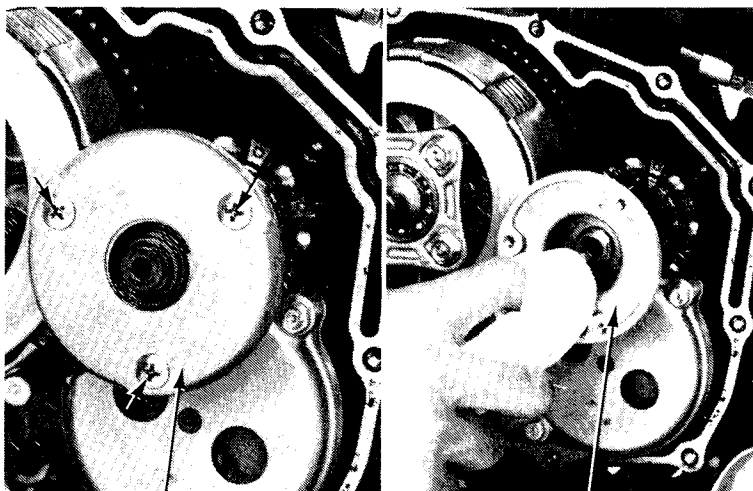

OIL FILTER ROTOR COVER

OIL FILTER ROTOR

Install the dowel pins and gasket.

Install the right crankcase cover (page 8-14).

Adjust the rear brake pedal height (page 3-13).

Adjust the clutch lever free play and check the clutch operation (page 3-16).

Fill the crankcase with the recommended oil (page 2-2).

CONTROL CABLE LUBRICATION

Periodically disconnect the throttle, clutch and parking brake cables at their upper ends. Thoroughly lubricate the cables and their pivot points with a commercially available cable lubricant.

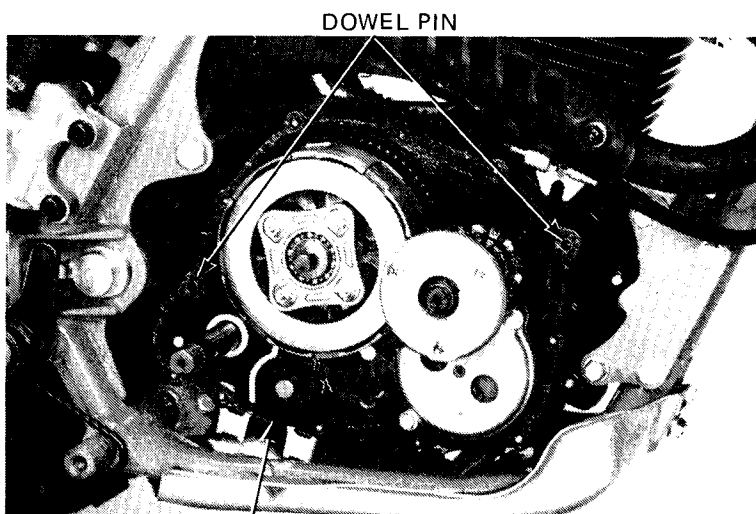

DOWEL PIN

GASKET

LUBRICATION

LUBRICATION POINTS

Use general purpose grease when no other specification is given. Apply oil or grease to any 2 sliding surfaces and cables not shown here.

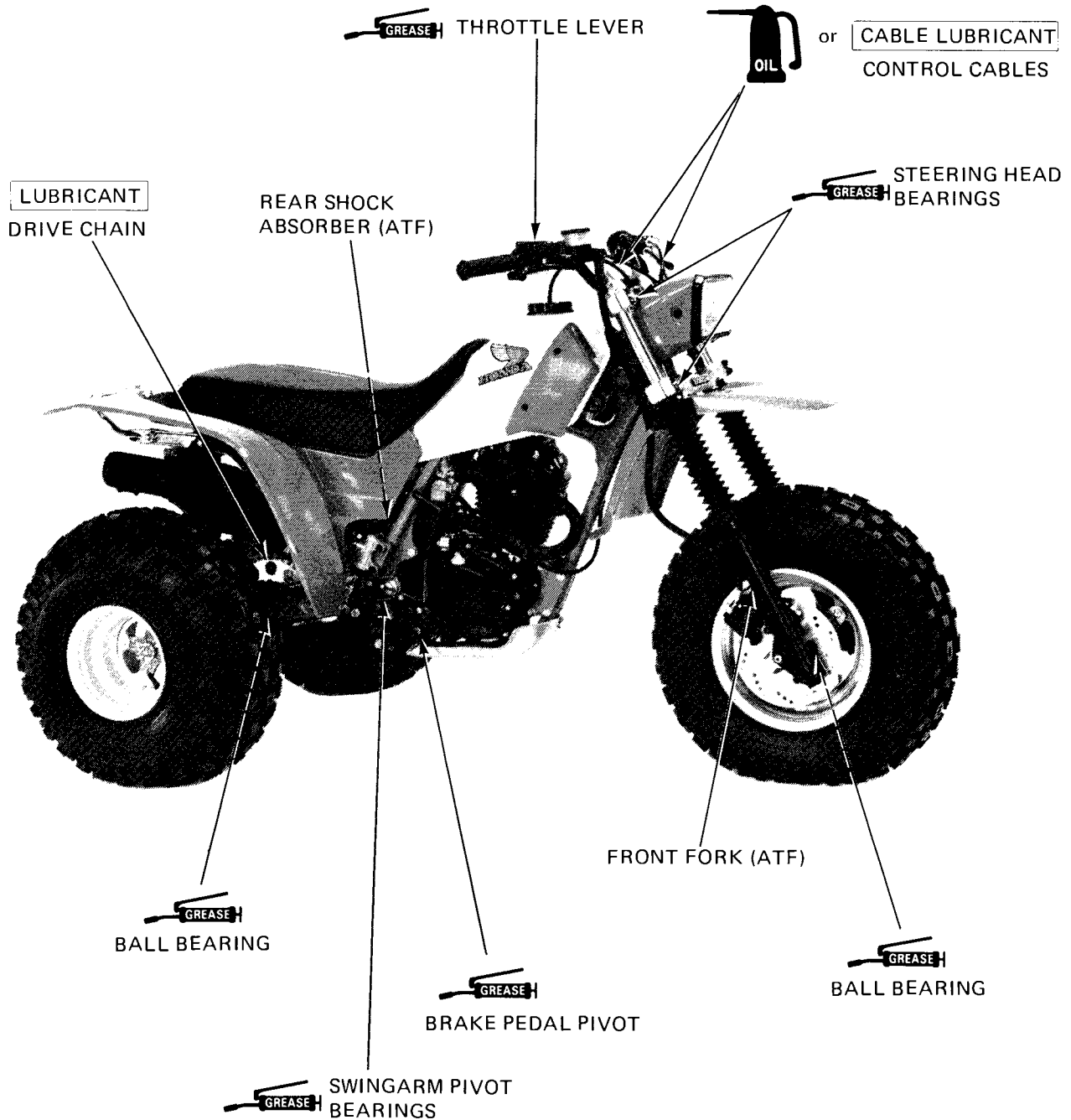

3. MAINTENANCE

SERVICE INFORMATION	3-1	DRIVE CHAIN	3-9
MAINTENANCE SCHEDULE	3-2	BRAKE FLUID	3-11
AIR CLEANER	3-3	BRAKE PADS	3-11
SPARK PLUG	3-4	BRAKE SYSTEM	3-12
VALVE CLEARANCE	3-5	CLUTCH	3-15
CARBURETOR IDLE SPEED	3-6	TIRES	3-15
FUEL LINE	3-6	STEERING HEAD BEARINGS	3-16
FUEL STRAINER	3-6	SUSPENSION	3-16
THROTTLE OPERATION	3-7	LIGHTING EQUIPMENT	3-17
CAM CHAIN TENSION	3-7	SPARK ARRESTER CLEANING	3-17
IGNITION TIMING	3-8	NUTS, BOLTS, FASTENERS	3-17
CYLINDER COMPRESSION	3-8		

SERVICE INFORMATION

SPECIFICATIONS

ENGINE

Ignition timing: Initial

1983	10° ± 2° BTDC at idle
After 1983	5° ± 2° BTDC at idle

Spark plug: Full advance
Spark plug gap
Recommended spark plugs:

30° ± 2° BTDC at 3,350 ± 150 rpm
0.6–0.7 mm (0.024–0.028 in)

NGK	DR8ES-L
ND	X24ESR-U
CHAMPION	RA6YC

Valve clearance: IN:
EX:

0.08 mm (0.003 in)
0.08 mm (0.003 in)
3–8 mm (0.12–0.31 in)

Throttle lever free play:

Idle speed:

1,300 ± 100 rpm

Cylinder compression:

1,128 kPa (11.5 kg/cm², 164 psi)

CHASSIS

Drive chain slack:

25–35 mm (0.98–1.38 in)

Rear brake pedal height:

0–10 mm (0–3/8 in)

Rear brake pedal pivot O.D.:

35.936–35.975 mm (1.4148–1.4163 in)

Rear brake pedal pivot bearing I.D.:

36.035–36.147 mm (1.4187–1.4231 in)

Clutch lever free play:

10–20 mm (3/8–3/4 in)

Front tire size, pressure

23.5 x 8–11, 23 kPa (0.23 kg/cm², 3.3 psi)

Rear tire size, pressure

22 x 11–8, 17 kPa (0.17 kg/cm², 2.4 psi)

Front/rear tire circumference

1,895 mm (74.6 in)/1,745 mm (68.7 in)

Front suspension air pressure

0 kPa (0 kg/cm², 0 psi)

MAINTENANCE

TORQUE VALUE

Swingarm pivot bolt

70–110 N·m (7.0–11.0 kg·m, 51–80 ft·lb)

TOOLS

Common

Valve adjusting wrench, 10 x 12 mm
Valve adjuster

07708–0030200 }
07708–0030300 } Equivalent tools commercially available in U.S.A.

MAINTENANCE SCHEDULE

The maintenance intervals shown in the following schedule are based upon average riding conditions. ATC's subjected to severe use, or ridden in unusually wet or dusty areas, require more frequent servicing.

I: Inspect and Clean, Adjust, Lubricate or Replace, if necessary C: Clean R: Replace A: Adjust L: Lubricate		INITIAL SERVICE PERIOD (First week of operation)	REGULAR SERVICE PERIOD (Every 30 operating days)	Refer to page
ENGINE OIL	NOTE (1), (2)	R	R	2-2
ENGINE OIL FILTER SCREEN		C	C	2-2
* ENGINE OIL FILTER ROTOR			C	2-3
AIR CLEANER ELEMENT	NOTE (2)		C	3-3
SPARK PLUG			I	3-4
* VALVE CLEARANCE		I	I	3-5
* CARBURETOR		I	I	3-6
FUEL LINE		I : (EVERY YEAR)		3-6
* FUEL FILTER		C : (EVERY YEAR)		3-6
THROTTLE OPERATION		I	I	3-7
* CAM CHAIN TENSIONER		A	A	3-7
DRIVE CHAIN	NOTE (2)	I, L	I, L	3-9
DRIVE CHAIN SLIDER		I	I	3-11
BRAKE FLUID		I	I, R: (EVERY YEAR)	3-12
* BRAKE PADS	NOTE (3)	I: (EVERY YEAR)		3-12
BRAKE SYSTEM		I	I	3-13
** REAR BRAKE PIVOTS		I: (EVERY YEAR)		3-15
* SUSPENSION			I	3-17
FRONT FORK OIL/AIR		R: (EVERY YEAR)		3-17
SWINGARM BEARING		I, L	I, L	—
* CLUTCH		A	A	3-16
* SPARK ARRESTER			C	3-18
ALL NUTS, BOLTS, FASTENERS		I	I	3-18
LIGHTING EQUIPMENT		I	I	3-18
TIRES		I	I	3-16
* STEERING HEAD BEARING		A : (EVERY YEAR)		3-17

* Should be serviced by an authorized Honda dealer, unless the owner has proper tools and service data and is mechanically qualified.

** In the interest of safety, we recommend these items be serviced ONLY by an authorized HONDA dealer.

NOTE: (1) Replace every 30 operating days or every 3 months, whichever comes first.

(2) Service more frequently when riding in dusty areas.

(3) Service more frequently after riding in very wet or muddy conditions.

AIR CLEANER

Remove the seat/rear fender.

Release the four clips retaining the air cleaner cover.
Remove the air cleaner cover.

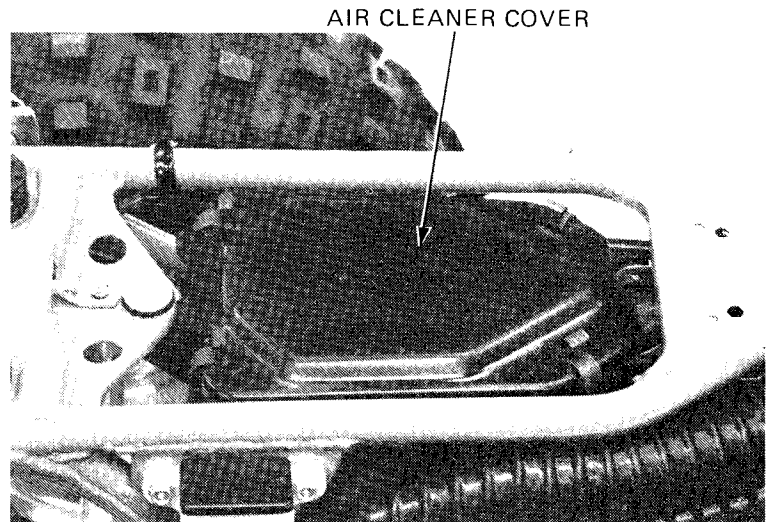

Remove the screw attaching the element holder stay, and remove the stay, element and holder assembly from the case.

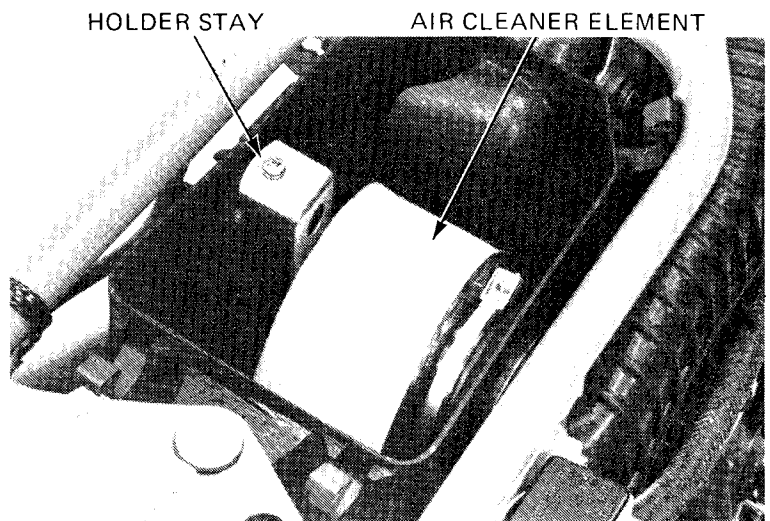

Loosen the element band.
Remove the stay by turning it counterclockwise.
Remove the element from the holder.

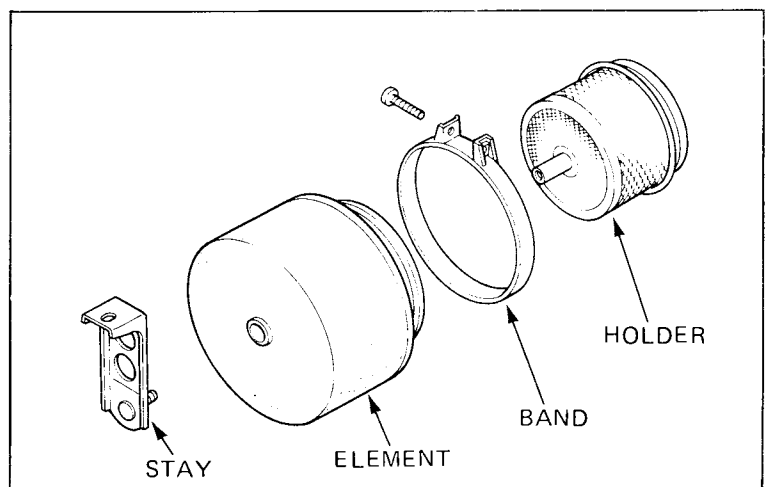

MAINTENANCE

Wash the element in non-flammable or high flash point solvent, squeeze out the solvent thoroughly, and allow to dry.

Soak the element in gear oil (SAE 80–90) and squeeze out excess.

Reinstall the air cleaner element on the element holder.

Install the element holder stay to the holder and tighten the element band to secure the element.

Apply a light coat of grease to the sealing edge of the element holder.

Reinstall the element holder and secure it with the attaching screw.

Reinstall the air cleaner cover and the seat/rear fender.

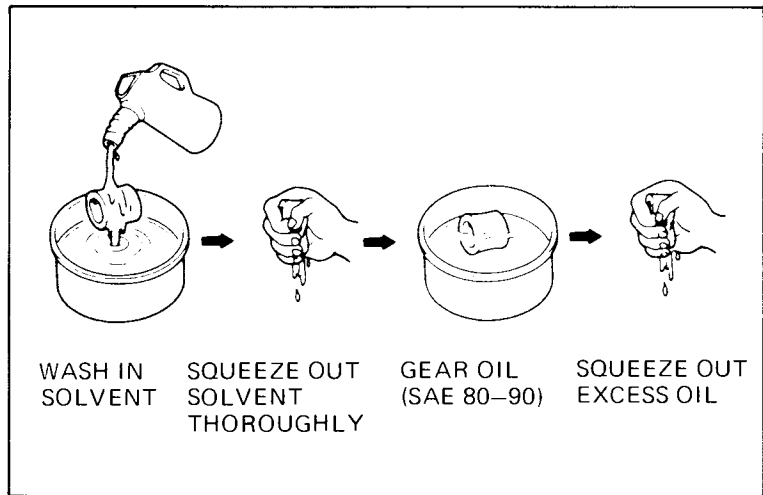

SPARK PLUG

Disconnect the spark plug cap and remove the spark plug.

Visually inspect the spark plug electrodes for wear. The center electrode should have square edges and the side electrode should have a constant thickness. Discard the spark plug if there is apparent wear or if the insulator is cracked or chipped. Measure the gap with a wire-type feeler gauge and adjust by carefully bending the side electrode.

SPARK PLUG GAP: 0.6–0.7 mm (0.024–0.028 in)

RECOMMENDED SPARK PLUG:

NGK	DR8ES-L
ND	X24ESR-U
CHAMPION	RA6YC

Check the sealing washer and replace with a new one if damaged.

Install the spark plug, tighten it by hand, then tighten with a spark plug wrench.

NOTE:

Tighten a new spark plug 1/2 turn to compress the washer. If reusing a spark plug, it should only take 1/8–1/4 turn after the plug seats.

Connect the spark plug cap.

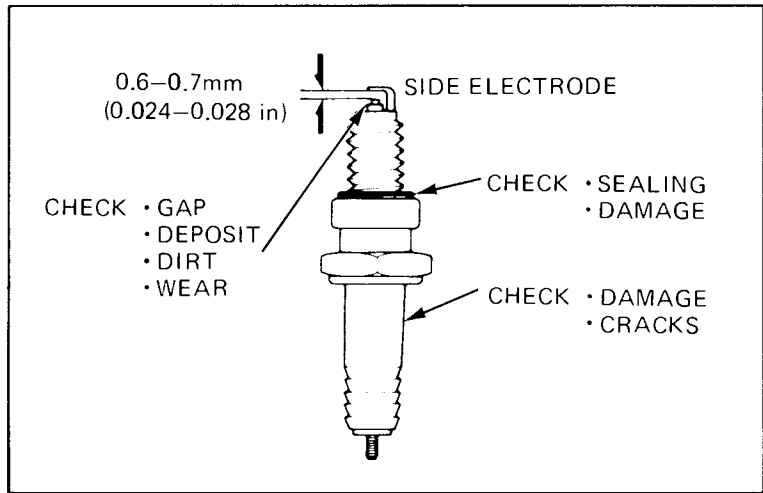

VALVE CLEARANCE

NOTE:

Inspect and adjust valve clearance while the engine is cold (below 35°C/95°F).

Remove the seat/rear fender.
 Turn the fuel valve OFF and disconnect the fuel tube.
 Remove the fuel tank.
 Remove the crankshaft hole cap and timing mark hole cap.

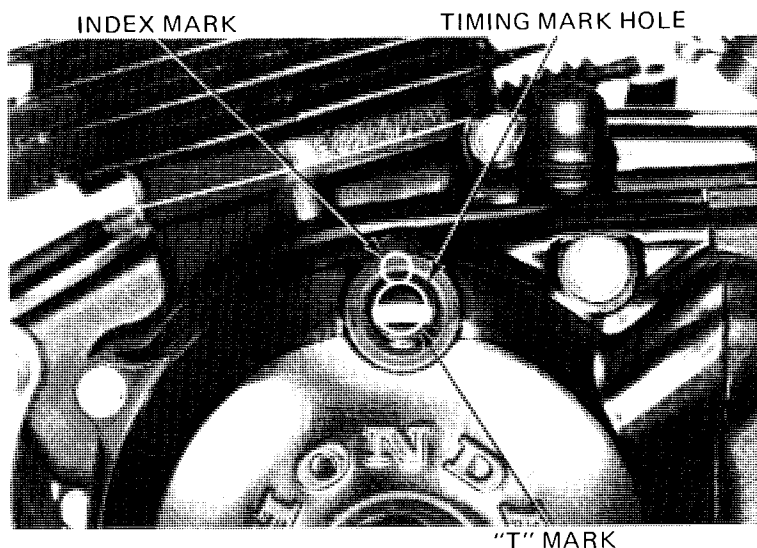

Remove the valve adjuster covers.
 Rotate the crankshaft counterclockwise and align the "T" mark on the generator rotor with the index mark on the left crankcase cover. The piston must be at TDC of the compression stroke (both rocker arms loose).

Inspect the intake and exhaust valve clearances by inserting the feeler gauge between the adjusting screw and valve stem.

VALVE CLEARANCES:

- INTAKE: 0.08 mm (0.003 in)
- EXHAUST: 0.08 mm (0.003 in)

Adjust by loosening the lock nut and turning the adjusting screw until there is a slight drag on the feeler gauge.

Hold the adjusting screw and tighten the lock nut.

Recheck the valve clearance.

Install the valve adjuster covers.
 Install the timing hole cap and crankshaft hole cap.
 Install the fuel tank and the seat/rear fender.

Reconnect the fuel tube.

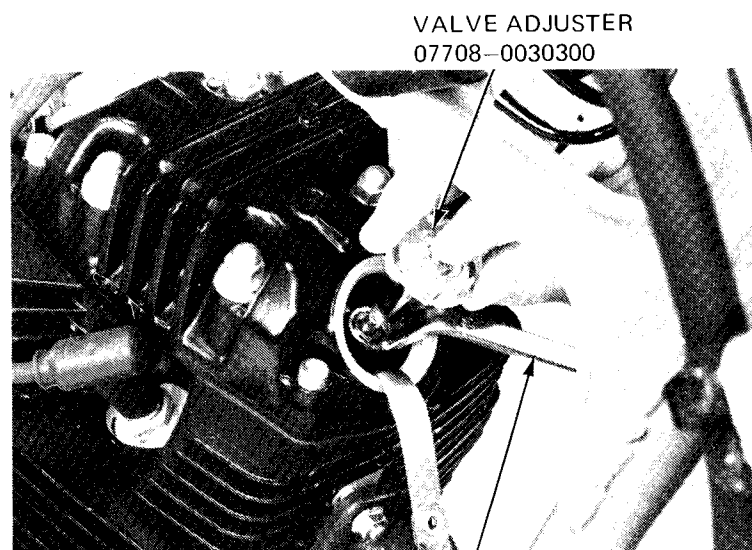
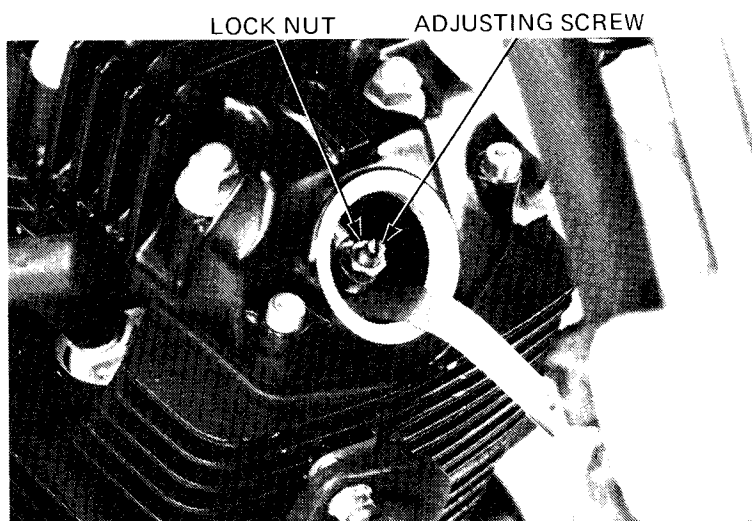

VALVE ADJUSTING WRENCH, 10 x 12 mm 07708-0030200 OR EQUIVALENT COMMERCIALY AVAILABLE TOOL

MAINTENANCE

CARBURETOR IDLE SPEED

NOTE:

- Inspect and adjust the idle speed after all other maintenance items have been performed and are within specifications.
- The engine must be warm for accurate idle speed inspection and adjustment. Stop and go riding for ten minutes is sufficient.

After warming up the engine, shift the transmission into neutral and connect a tachometer.

Turn the throttle stop screw as required to obtain the specified idle speed.

IDLE SPEED: 1,300 ± 100 rpm

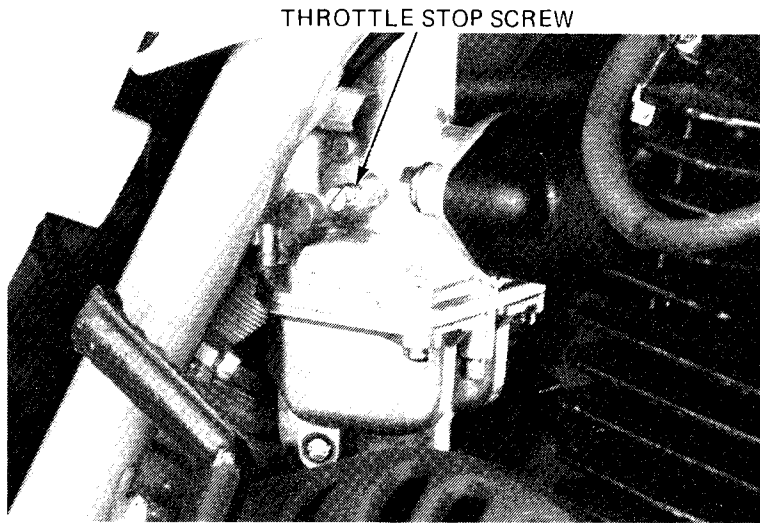

FUEL LINE

Replace any parts which show signs of deterioration, damage or leaks.

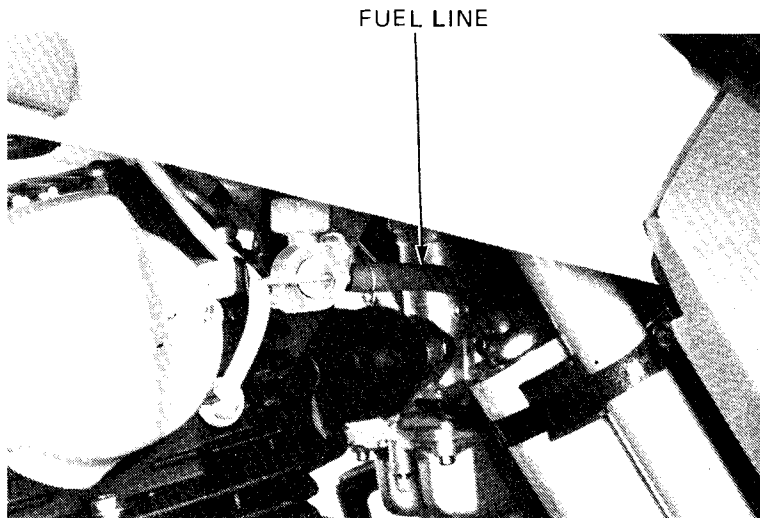

FUEL STRAINER

Disconnect the fuel tube.
Drain fuel from the fuel tank into a suitable container.

WARNING

*Keep gasoline away from flames or sparks.
Wipe up spilled gasoline at once.*

Remove the fuel valve by loosening the valve nut.
Remove and clean the strainer.
Install the strainer and valve.
Attach the fuel line.
Fill the fuel tank and turn the fuel valve to "ON"
and check for leaks.

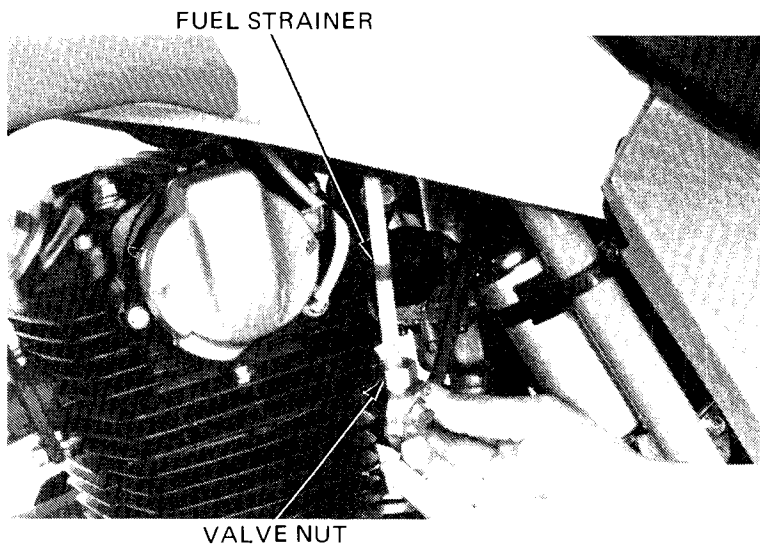

THROTTLE OPERATION

Check for smooth throttle lever full opening and automatic full closing in all steering positions. Make sure there is no deterioration, damage or kinking in the throttle cable. Replace any damaged parts.

Disconnect the throttle cable at the upper end. Thoroughly lubricate the cable and pivot points with a commercially available cable lubricant to prevent premature wear.

Install the throttle cable in the reverse order of removal.

Measure the throttle lever free play at the tip of the throttle lever.

THROTTLE LEVER FREE PLAY:
3–8 mm (0.12–0.31 in)

Throttle lever free play can be adjusted at either end of the throttle cable.

Adjust the throttle lever free play by loosening the lock nut turning the adjuster.

Turn the adjuster in direction A to increase the free play. Turn the adjuster in direction B to decrease the free play.

After adjustment, tighten the lock nut securely.

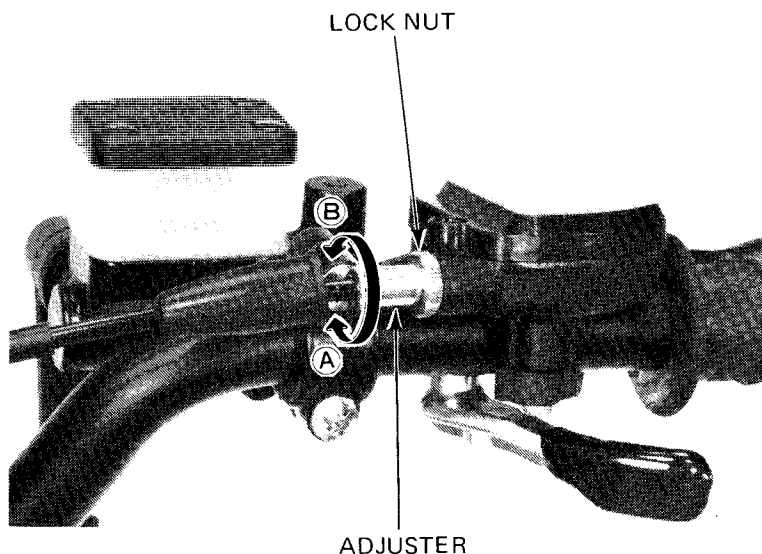
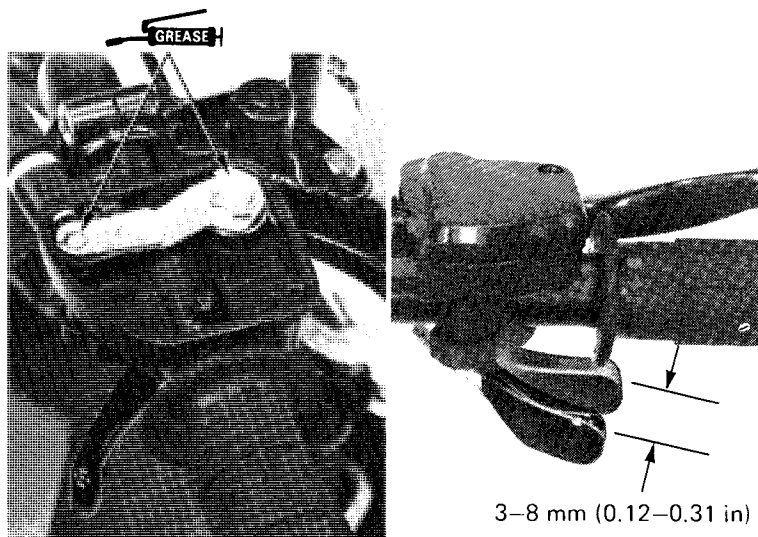

CAM CHAIN TENSION

Start the engine and allow it to idle. Remove the rubber cap and loosen the cam chain tensioner adjusting bolt.

When the cam chain tensioner adjusting bolt is loosened, the tensioner will automatically position itself to provide the correct tension.

Retighten the adjusting bolt and install the rubber cap.

TORQUE: 15–22 N·m (1.5–2.2 kg·m, 11–16 ft·lb)

NOTE:

Do not loosen the 6 mm bolt.

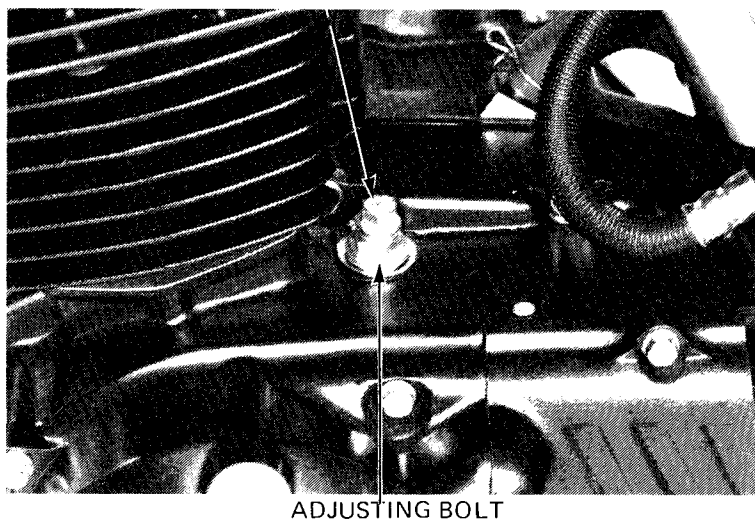

IGNITION TIMING

NOTE:

The Capacitive Discharge Ignition (CDI) system is factory pre-set and does not require adjustment. To inspect the function of the CDI components, ignition timing inspection procedures are given here.

Remove the timing hole cap.
Connect a tachometer and timing light.
Start the engine and allow it to idle.

IDLE SPEED: 1,300 ± 100 rpm

Inspect the ignition timing.
Timing is correct, if the "F" mark on the generator rotor is aligned with the index mark on the left crankcase cover at idle.

See Section 16 for the full advance checking procedure.

If the ignition timing is incorrect, refer to page 16-6.

CYLINDER COMPRESSION

Warm up the engine.
Stop the engine and remove the spark plug.
Insert a compression gauge.

Push the choke lever down fully.
Open the throttle lever fully.
Operate the kick starter pedal several times.

NOTE:

Be sure compression does not leak at the gauge connection.

COMPRESSION:

1,128 kPa (11.5 kg/cm² , 164 psi)

Low compression can be caused by:

- Improper valve adjustment.
- Valve leakage.
- Blown cylinder head gasket.
- Worn piston ring or cylinder.

High compression can be caused by:

- Carbon deposits in combustion chamber or on piston head.

VALVE TIMING
INSPECTION HOLE

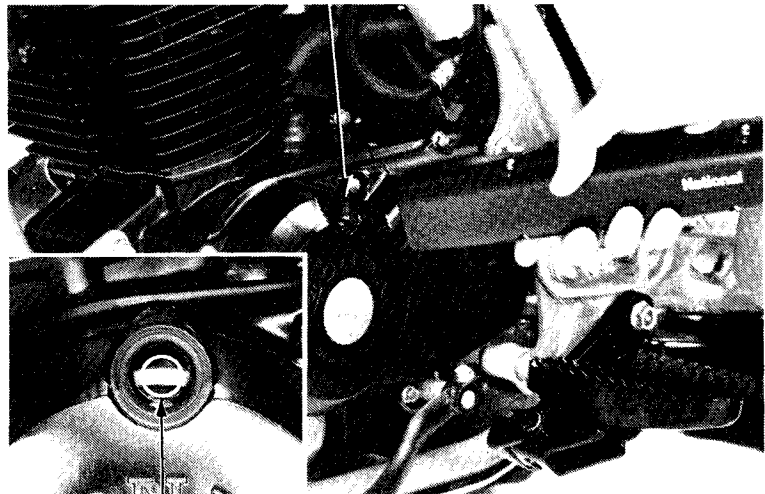

"F" MARK

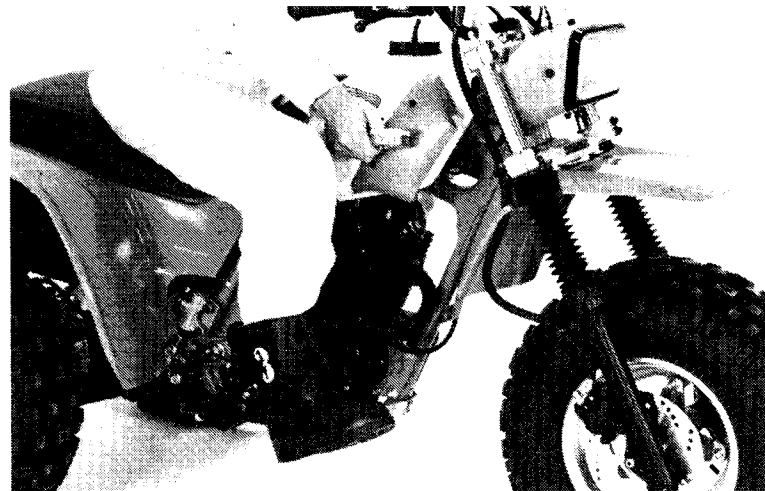

DRIVE CHAIN

INSPECTION

Shift the transmission into neutral.
Measure the drive chain slack midway between the sprockets on the upper chain run.

CHAIN SLACK: 25–35 mm (0.98–1.38 in)

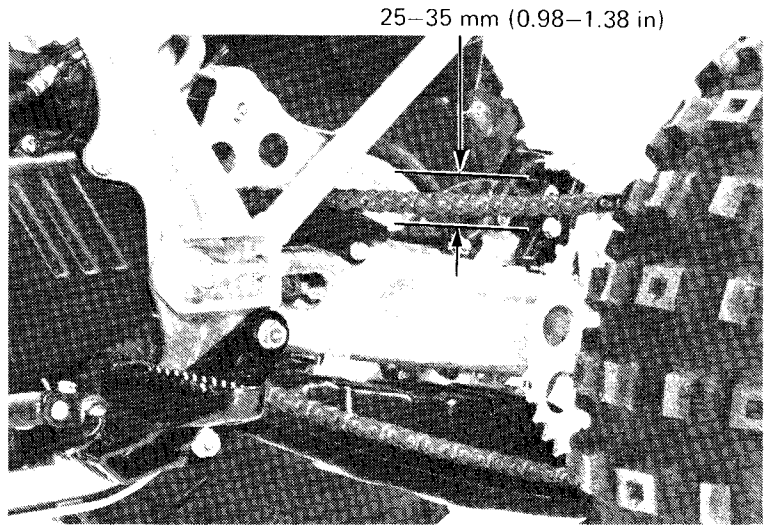

DRIVE CHAIN ADJUSTMENT

Loosen the swingarm pivot bolt nut.
Loosen the chain adjuster lock nuts.
Turn both right and left adjuster nuts equally to increase or decrease the chain slack until it is within specification.

If the drive chain is worn and adjustment cannot be performed with the adjusters, replace the drive chain with a new one.

Tighten the swingarm pivot bolt nut.

TORQUE:

70–110 N·m (7.0–11.0 kg·m, 51–80 ft·lb)

Tighten the adjuster lock nuts.

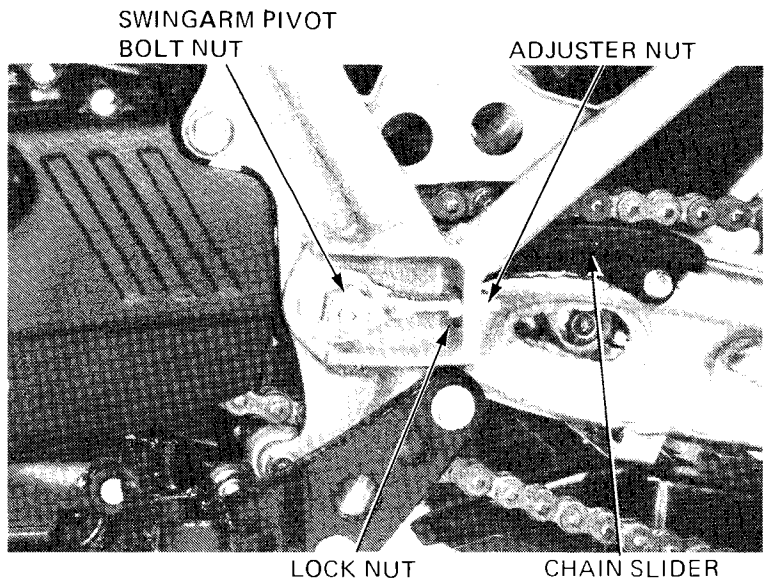

CHAIN SLIDER INSPECTION

Check the chain slider for wear.
If it is excessively worn, replace it.

DRIVE CHAIN AND SPROCKET INSPECTION

When the drive chain becomes extremely dirty, it should be removed and cleaned prior to lubrication.

Remove the gearshift pedal and the drive sprocket cover.

Remove the chain clip, O-rings and master link and disconnect the drive chain.

Remove the drive chain.

NOTE:

Do not lose the four O-rings.

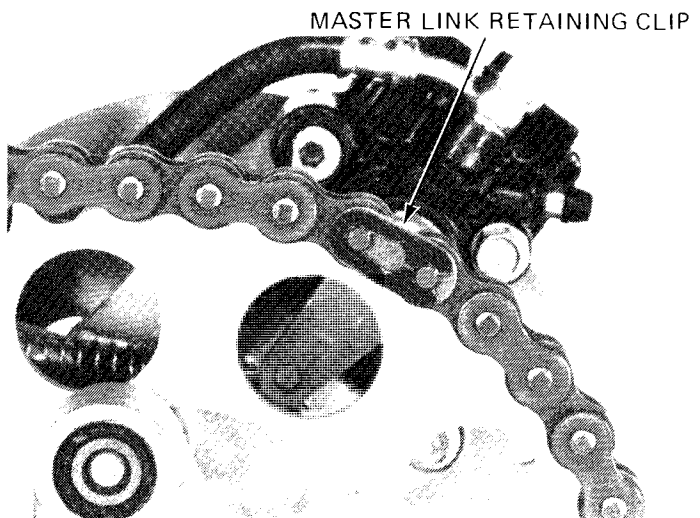

MAINTENANCE

Clean the drive chain with kerosene or a high flash point solvent that will not damage the O-rings, and wipe dry.

CAUTION:

Do not use a steam cleaner, high pressure washers or solvents as these will damage the O-rings.

Lubricate the drive chain with SAE 80 or 90 gear oil.

CAUTION:

Do not use commercial aerosol chain lubricants. They contain solvents which could damage the O-rings.

Inspect the drive chain and O-rings for possible wear or damage. Replace the chain if it is worn excessively or damaged.

Inspect the sprocket teeth for excessive wear or damage. Replace if necessary.

NOTE:

Never install a new drive chain on worn sprockets or a worn chain on new sprockets. Both chain and sprockets must be in good condition, or the new replacement chain or sprockets will wear rapidly.

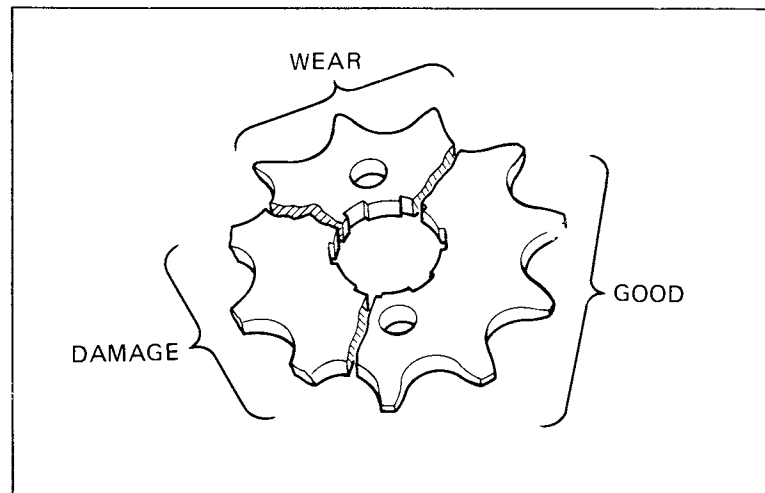
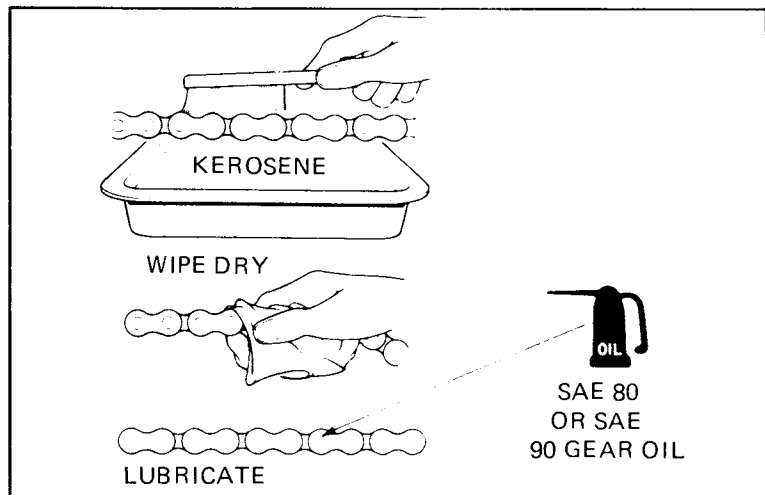

Install the drive chain.

Install the master link with O-rings and chain retaining clip.

NOTE:

The closed end of the clip should face the direction of drive chain travel.

CAUTION:

- *Do not assemble the drive chain without the four O-rings.*
- *Be sure that there is no space between the master link and chain retaining clip.*

Install the drive sprocket cover and gearshift pedal. Adjust the drive chain (page 3-9).

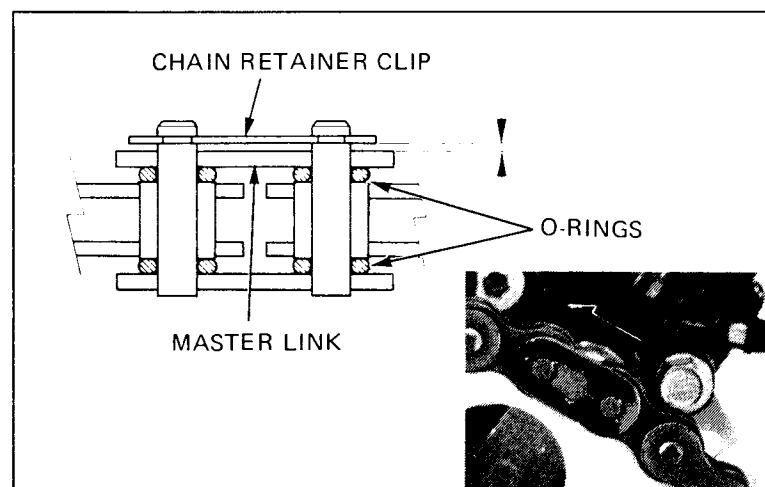

BRAKE FLUID

Check the front and rear brake fluid reservoir level. If the level nears the lower level mark, remove the cap and fill the reservoir with DOT-3 brake fluid to the upper level mark. The upper level mark is inside the reservoir.

Check the entire system for leaks, if the level is low.

CAUTION:

- Do not remove the cover until the handlebar has been turned so that the reservoir is level.
- Avoid operating the brake lever with the cap removed. Brake fluid will squirt out if the lever is pulled.

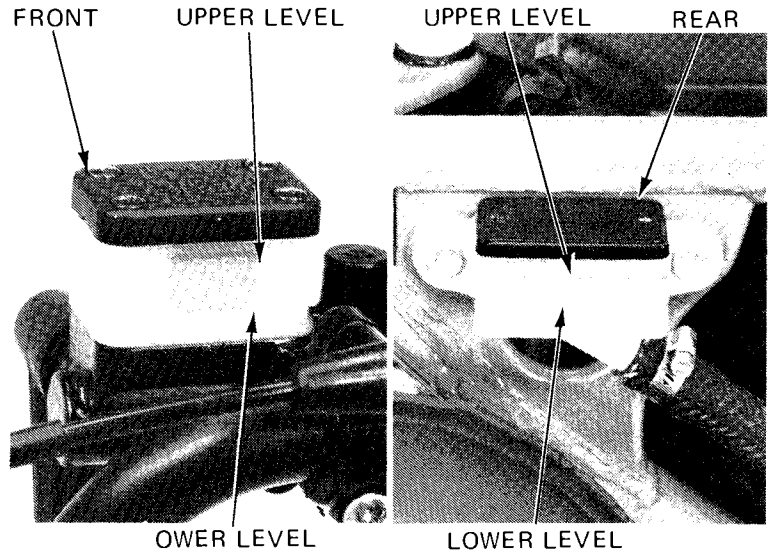

BRAKE PADS

Check the front and rear brake pads for wear.

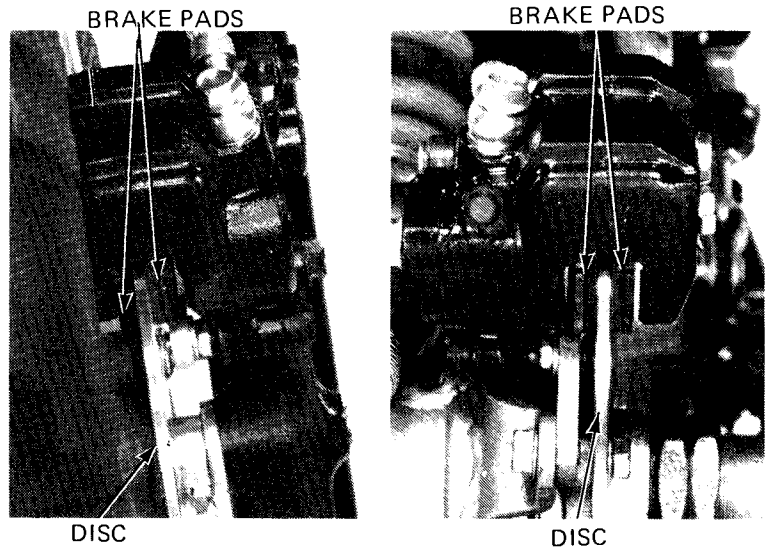

Replace the pads if they are worn to the service limit groove.

CAUTION:

- Always replace the brake pads as a set to assure even disc pressure.

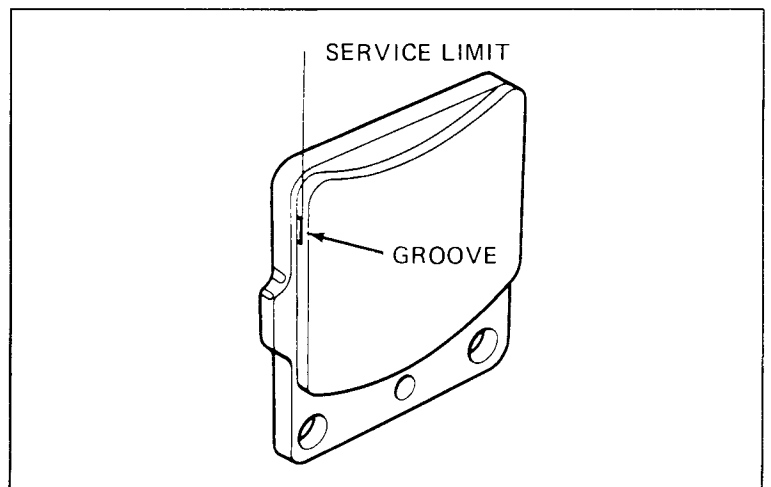

MAINTENANCE

BRAKE SYSTEM

Check that there is no deterioration, damage or leaks in brake lines or fittings.

REAR BRAKE PEDAL HEIGHT

Adjust the pedal height so that the distance between the pedal and upper face of the footpeg is correct.

PEDAL HEIGHT: 0–10 mm (0–3/8 in)

Adjust as follows:

Loosen the lock nut and screw the stopper bolt all the way in.

Loosen the adjuster lock nut and turn the adjuster until the correct pedal height is obtained.

Tighten the lock nut.

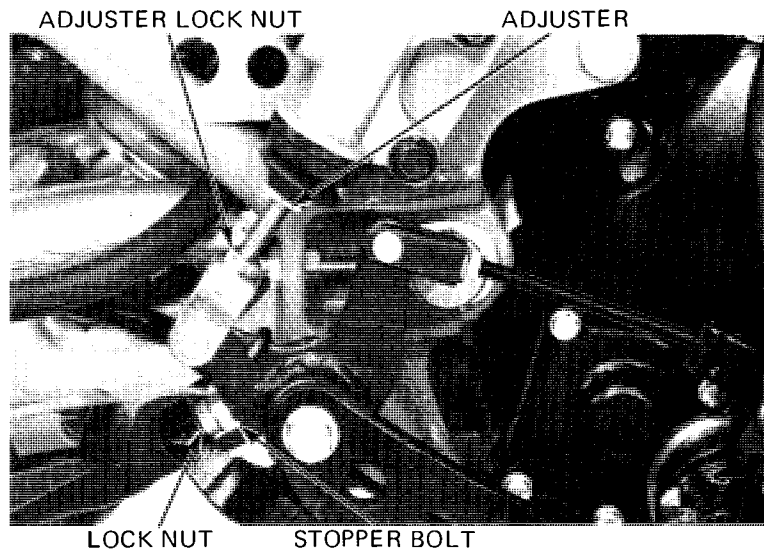

Turn the stopper bolt out until the distance between the brake arm and stopper bolt is 0.1–0.5 mm (0.004–0.020 in).

CAUTION:

Do not allow the brake arm to contact the stopper bolt.

Tighten the lock nut.

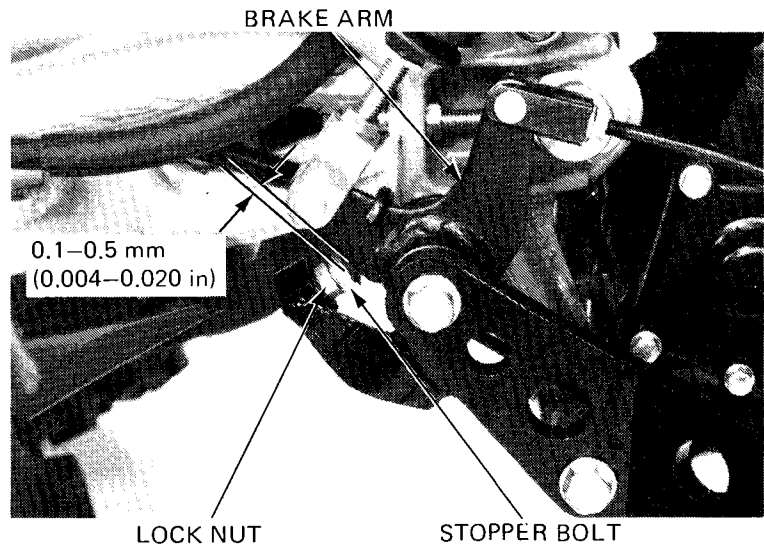

PARKING BRAKE

Apply the parking brake to lock the rear wheels.

Parking brake adjustment may be required if the parking brake does not hold the rear wheels properly.

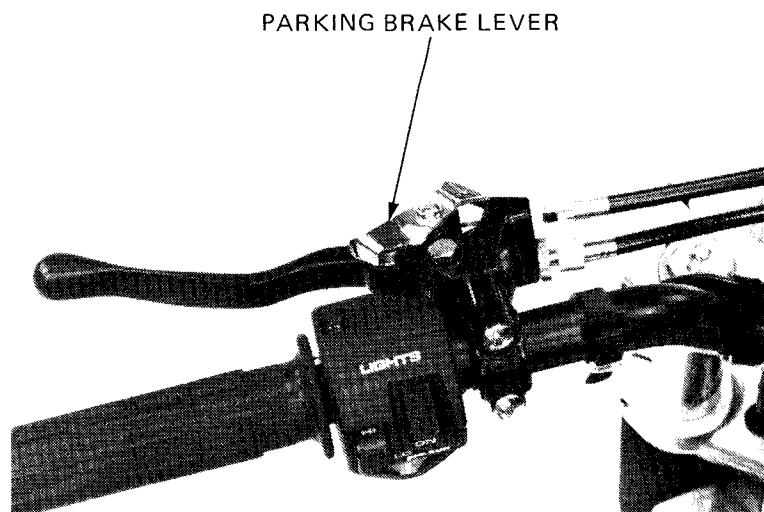

Adjust as follows:

Loosen the lock nut on the rear caliper.

Screw in the adjusting bolt until you feel resistance without applying the clutch/parking brake lever, and tighten the lock nut.

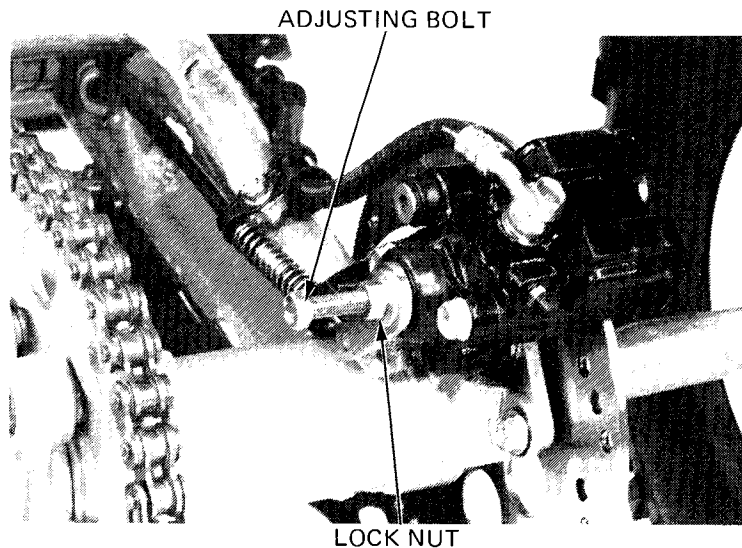

Press the parking brake arm button and pull in the clutch/parking brake lever.

Measure the distance the clutch/parking brake lever is moved.

The distance should be 31–39 mm (1.2–1.5 in) at the tip of the clutch/parking brake lever.

31–39 mm
(1.2–1.5 in)

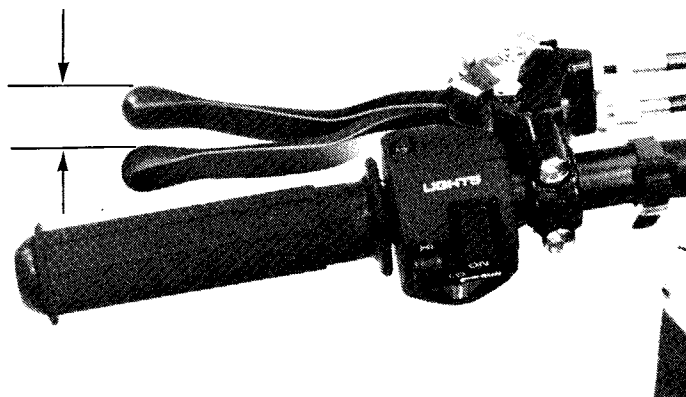

To adjust the distance, loosen the lock nut and turn the adjuster.

Tighten the lock nut.

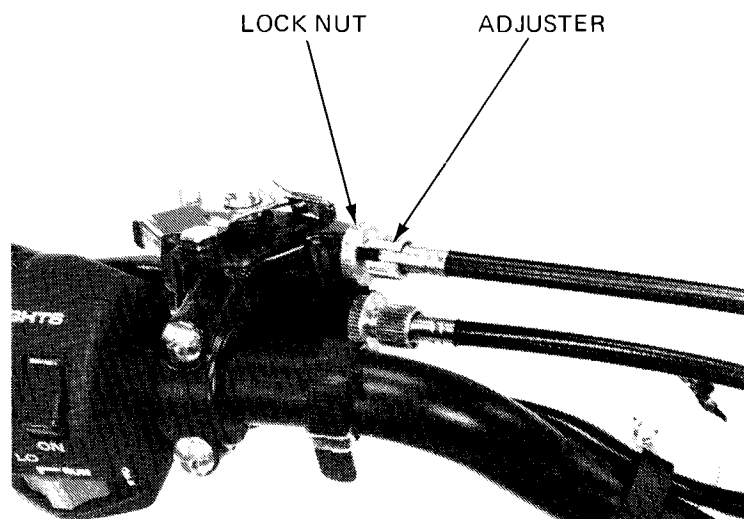

MAINTENANCE

REAR BRAKE PEDAL PIVOT

Remove the right foot peg bracket.
Remove the kick starter pedal.
Remove the cotter pin, washer and joint pin, and disconnect the brake rod from the brake arm.
Remove the brake pedal.

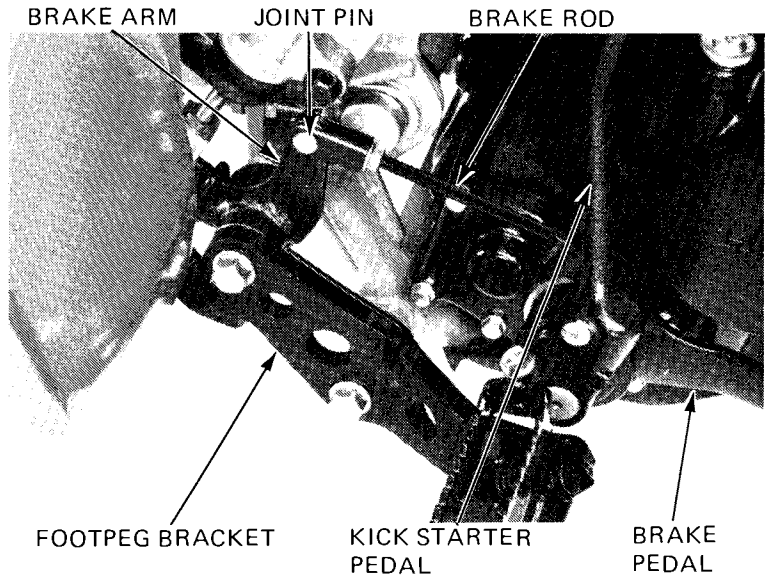

Measure the outside diameter of the brake pedal pivot.

SERVICE LIMIT: 35.7 mm (1.41 in)

If the pivot smaller than the service limit, replace the kick starter cover.

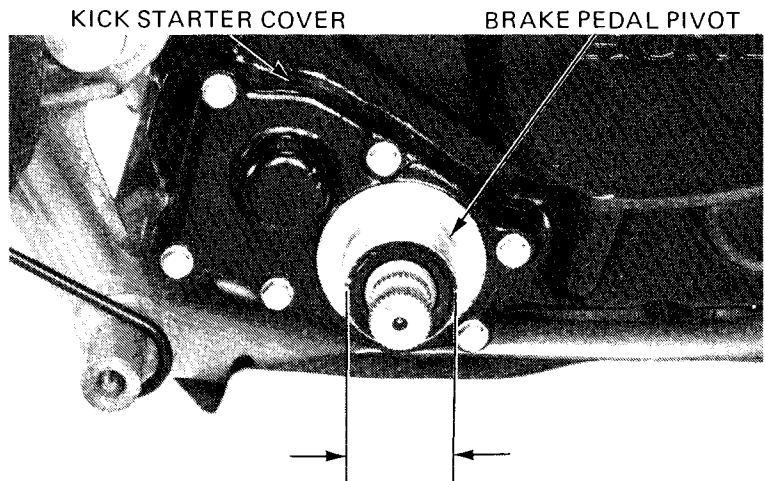

Measure the inside diameter of the brake pedal pivot bearing.

SERVICE LIMIT: 36.3 mm (1.43 in)

If the diameter is larger than the service limit, replace the rear brake pedal.

Check the inside of the pedal pivot for dirt and dust.

If the inside of the pivot is excessively dirty, replace the dust seals on both sides of the pedal pivot bearing.

Apply clean grease to the brake pedal pivot and the pivot bearing.

Reinstall the brake pedal, connect the brake rod to the brake arm and secure it with the washer and new cotter pin.

Reinstall the kick starter pedal and right footpeg bracket.

Check the rear brake pedal height and adjust if necessary (page 3-12).

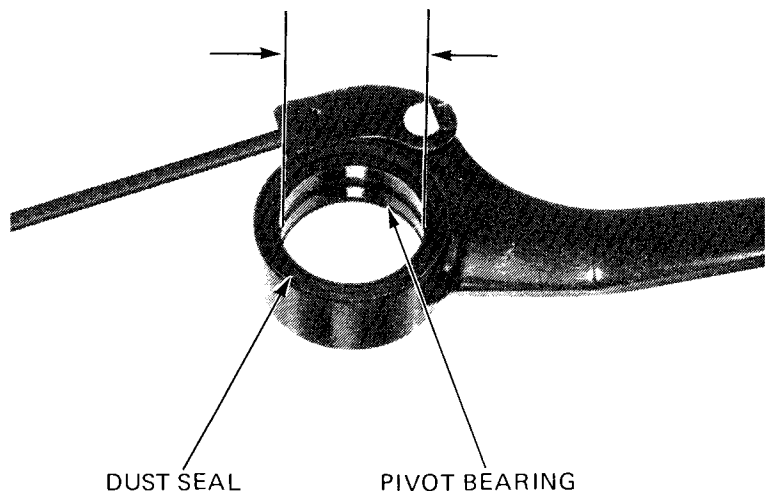

CLUTCH

Measure the clutch free play at the tip of the clutch lever.

CLUTCH LEVER FREE PLAY:
10–20 mm (3/8–3/4 in)

10–20 mm
(3/8–3/4 in)

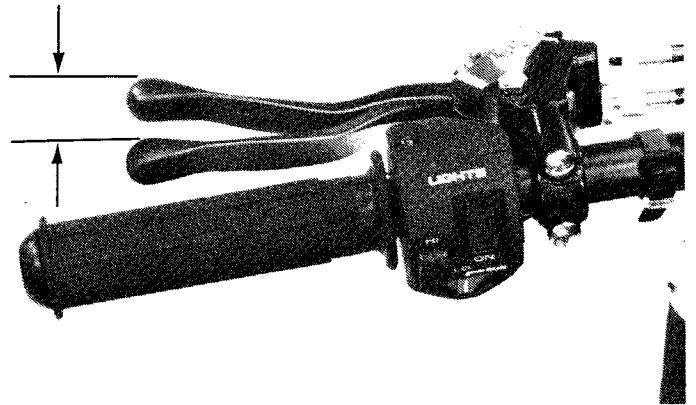

Perform major adjustments with the lower adjuster. Loosen the lock nut and turn the adjuster. Tighten the lock nut.

Perform minor adjustments with the upper adjuster. Loosen the lock nut and turn the adjuster. Tighten the lock nut.

Turn the adjuster in direction A to decrease free play. Turn the adjuster in direction B to increase free play.

Check the clutch operation.

LOCK NUT

LOWER ADJUSTER

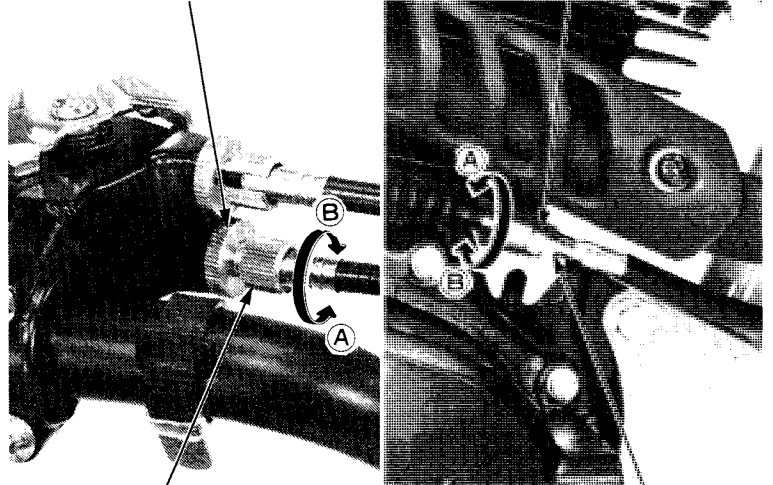

UPPER ADJUSTER

LOCK NUT

TIRES

Check the tire for cuts, imbedded nails, or other sharp objects.

NOTE:

Tire pressure should be checked when the tires are COLD.

Check the tire pressure and measure the tire circumference.

	Recommended pressure	Min. pressure	Max. pressure	Standard tire circumference
Front	3.3 psi (23 kPa, 0.23kg/cm ²)	2.8 psi (20 kPa, 0.2kg/cm ²)	3.7 psi (26 kPa, 0.26kg/cm ²)	1,895 mm (74.6 in)
Rear	2.4 psi (17 kPa, 0.17kg/cm ²)	2.0 psi (14 kPa, 0.14kg/cm ²)	2.8 psi (20 kPa, 0.2kg/cm ²)	1,745 mm (68.7 in)

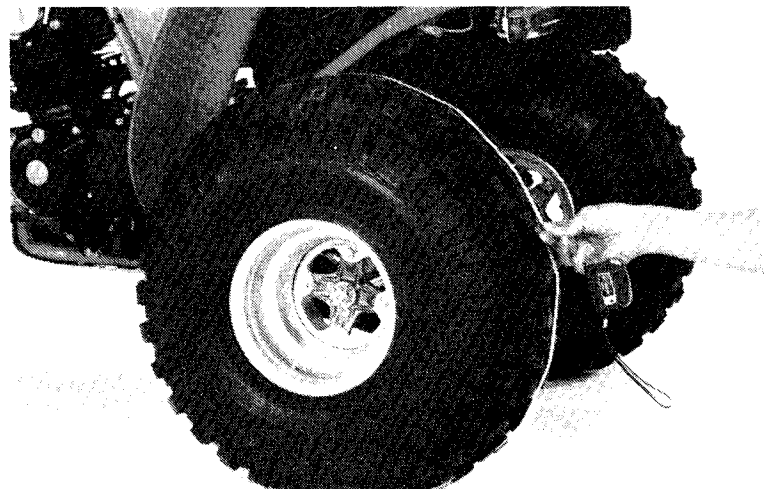

STEERING HEAD BEARINGS

NOTE:

Make sure the cables do not interfere with the rotation of the handlebar.

Raise the front wheel off the ground and make sure that the handlebar rotates freely.

If the handlebar moves unevenly, binds or has vertical play adjust the steering head bearing by turning the steering head adjusting nut with a pin spanner (page 11-30).

If after adjustment the handlebar still moves unevenly binds or has vertical play, inspect the steering head bearings and replace if necessary (page 11-26).

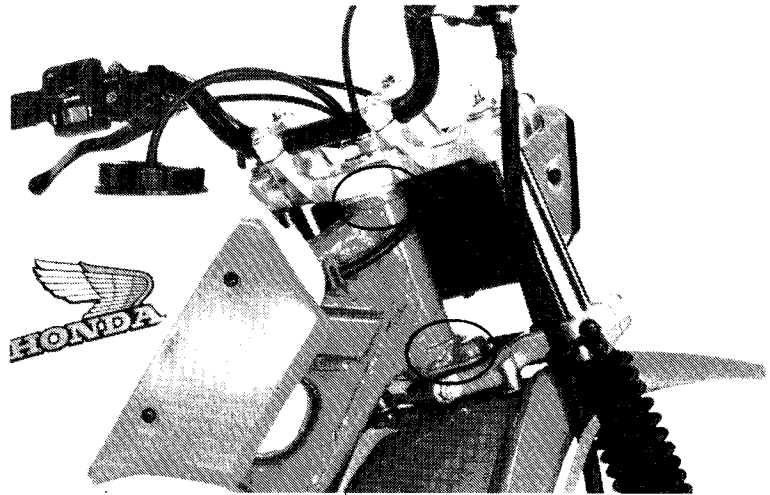

SUSPENSION

FRONT SUSPENSION

Check the action of the front forks by compressing them several times.

Check the entire fork assembly for signs of leaks or damage.

Replace damaged components which cannot be repaired.

NOTE:

Do not repair bent fork tubes. They must be replaced.

Tighten all nuts and bolts to the specified torque values.

Raise the front of the vehicle so that there is no weight on the front wheel.

Check air pressure in each fork tube (page 11-25).

AIR PRESSURE:

0 kPa (0 kg/cm², 0 psi)

To replace the front fork oil, refer to page 11-18).



REAR SUSPENSION

Check the operation of the rear suspension and the entire suspension assembly. Be sure it is securely mounted and not damaged or leaking. Make sure the spring is within the specified length (page 13-8).

Place the ATC on a support to raise the rear wheels off the ground.

Move the rear of the swingarm sideways forcefully to check the swingarm bearings for wear. No movement should be felt.

Tighten all nuts and bolts to their specified torque values (page 1-5).

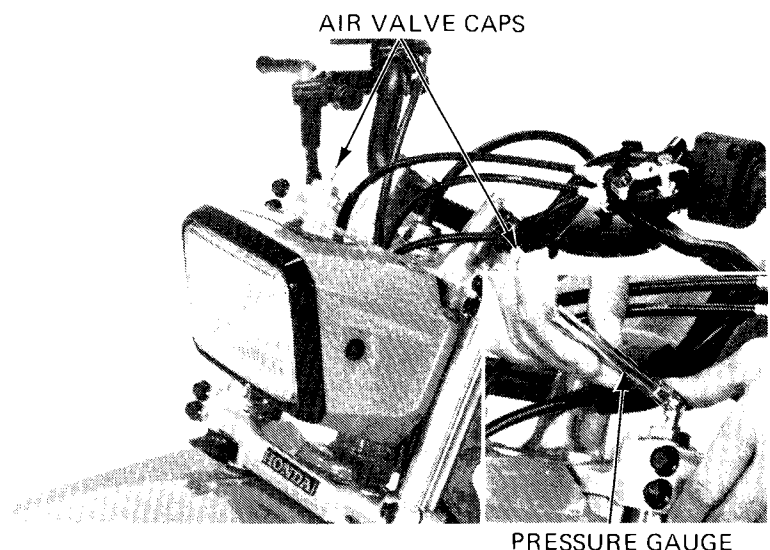

LIGHTING EQUIPMENT

Apply the parking brake.
Start the engine.

Check the headlight and taillight by operating the headlight ON-OFF switch and dimmer switch:

Headlight ON-OFF switch:

OFF: Lights are OFF

ON: Headlight and taillight are ON

Headlight dimmer switch:

HI: Headlight high beam and taillight are ON.

LO: Headlight low beam and taillight are ON.

Replace the bulb or switch as necessary.

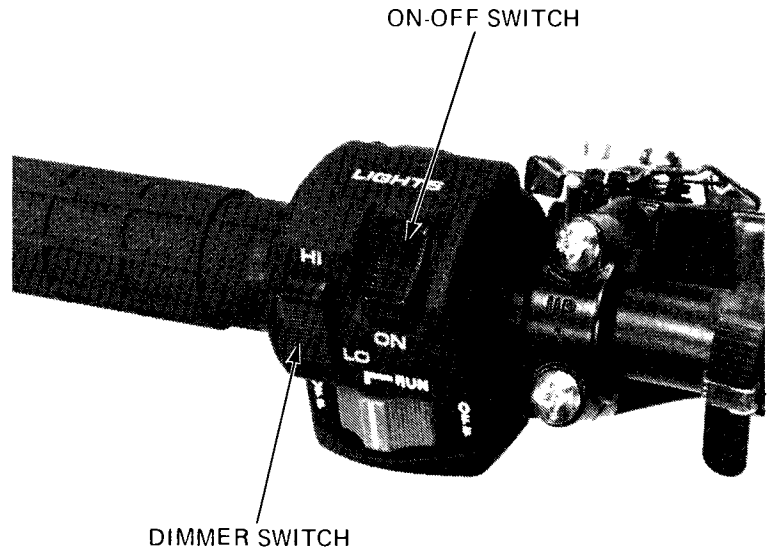

SPARK ARRESTER CLEANING

WARNING

- Do not remove or install the muffler lid while the exhaust pipe is hot. Perform this operation in a well-ventilated area, free from fire hazard.
- Use adequate eye protection.

Remove the muffler lid. Block the end of the exhaust pipe with a shop towel.

Start the engine and rev it up about 20 times to blow accumulated carbon deposits out the exhaust pipe.

Be sure that the muffler lid screws and packing are in good condition. Replace the screws and packing if necessary.

Install the muffler lid and packing and tighten the screws securely.

CAUTION:

- Do not remove the two screws from the end of the spark arrester.
- The two mounting screws must be installed in the spark arrester body at all times for the spark arrester to be effective.

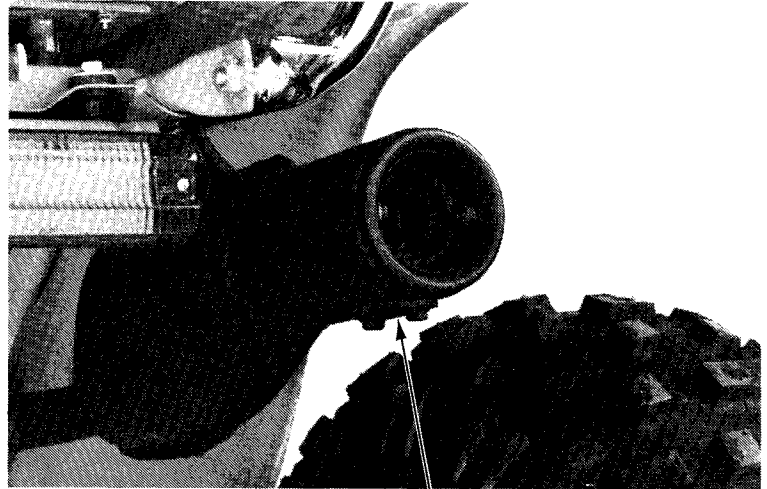

MUFFLER LID

NUTS, BOLTS, FASTENERS

Tighten bolts, nuts and fasteners at regular intervals shown in the Maintenance Schedule.

Check that all chassis nuts and bolts are tightened to their correct torque values (page 1-5). Check that all cotter pins and safety clips are in place.

FUEL SYSTEM

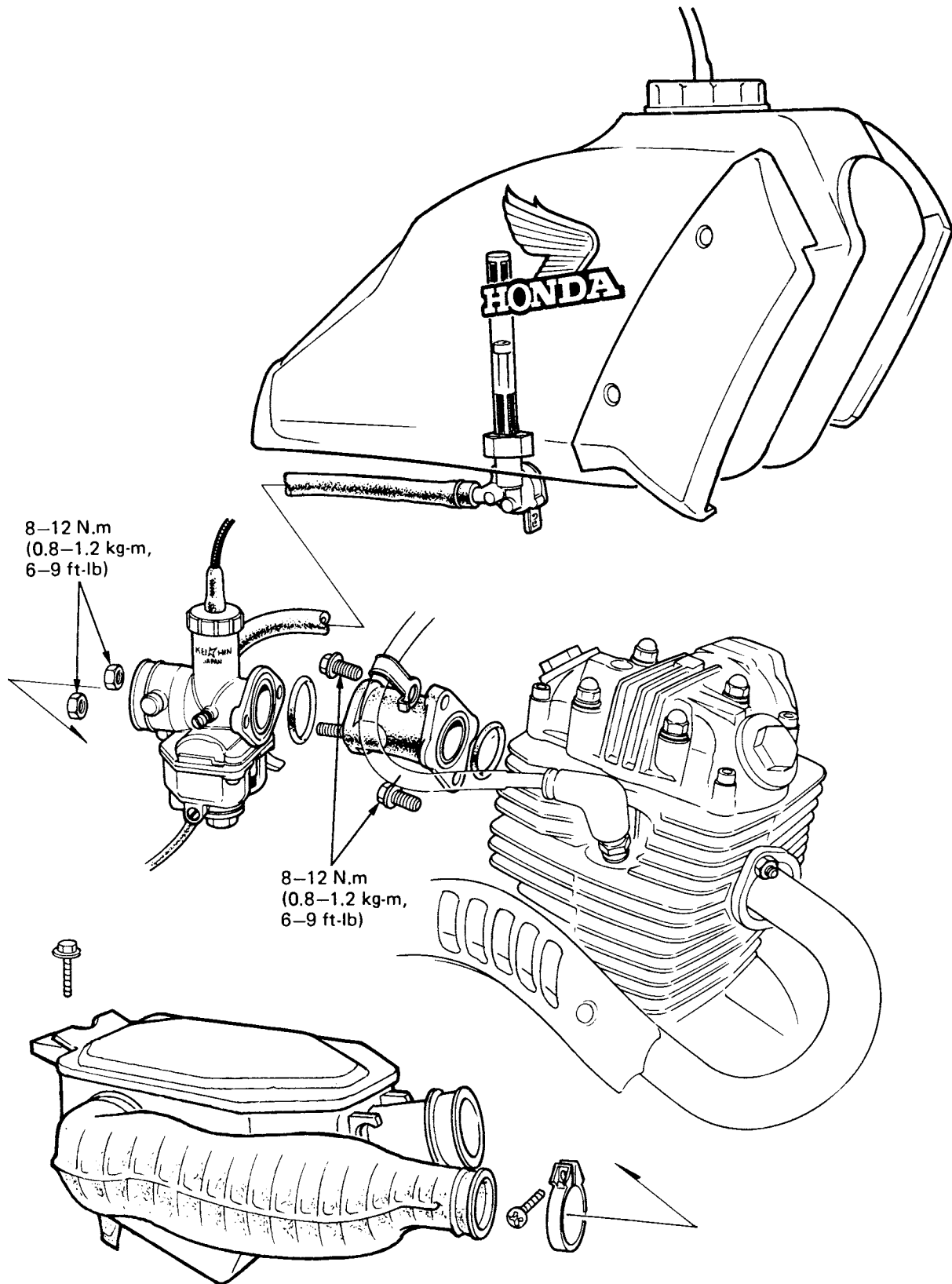

4. FUEL SYSTEM

SERVICE INFORMATION	4-1
TROUBLESHOOTING	4-2
FUEL TANK	4-3
AIR CLEANER CASE	4-4
CRANKCASE BREATHER	4-5
CARBURETOR REMOVAL	4-6
THROTTLE VALVE DISASSEMBLY	4-7
FLOAT, FLOAT VALVE AND JETS	4-7
CARBURETOR ASSEMBLY	4-8
FLOAT LEVEL ADJUSTMENT	4-9
THROTTLE VALVE ASSEMBLY	4-9
CARBURETOR INSTALLATION	4-9
PILOT SCREW ADJUSTMENT	4-10
HIGH ALTITUDE ADJUSTMENT	4-10

SERVICE INFORMATION

GENERAL

Use caution when working with gasoline. Always work in a well ventilated area away from sparks or flames. When disassembling fuel system parts, note the locations of the O-rings. Replace them with new ones during reassembly. The carburetor float bowl has a drain plug that can be loosened to drain residual fuel.

SPECIFICATIONS

Fuel tank capacity 9.7 liters (2.56 US gal, 2.14 Imp gal)
Fuel reserve capacity 1.4 liters (0.37 US gal, 0.31 Imp gal)

Carburetor	1983	After 1983
Identification mark	PD62A	PD62B
Type	Piston valve	←
Venturi dia	24 mm (0.94 in)	←
Float level	14 mm (0.55 in)	←
Pilot screw opening	1-3/4	2-1/4
Idle speed	1,300 ± 100 rpm	←
Main jet	#110	#108
Throttle lever free play	3-8 mm (0.12-0.31 in)	←

TOOL

Common
Float level gauge: 07401-0010000

TROUBLESHOOTING

Engine cranks but won't start

1. No fuel in tank.
2. No fuel to cylinder.
3. Too much fuel getting to cylinder.
4. No spark at plug (ignition malfunction).
5. Air cleaner clogged.

Engine idles roughly, stalls, or runs poorly

1. Idle speed incorrect.
2. Ignition malfunction.
3. Rich mixture.
4. Lean mixture.
5. Air cleaner dirty.
6. Air leaks into intake pipe.

Lean mixture

1. Carburetor fuel jet clogged.
2. Fuel cap vent blocked.
3. Breather tube clogged.
4. Fuel filter clogged.
5. Fuel line kinked or restricted.
6. Float valve faulty.
7. Float level too low.

Rich mixture

1. Carburetor choke stuck closed.
2. Float valve faulty.
3. Float level too high.
4. Carburetor air jet clogged.
5. Air cleaner dirty.

FUEL TANK

Remove the seat/rear fender.
 Turn the fuel valve OFF, and disconnect the fuel tube.
 Remove the fuel tank.

WARNING

*Keep gasoline away from flames or sparks.
 Wipe up spilled gasoline at once.*

Check that fuel flows freely out of the fuel valve.
 If flow is restricted, remove the fuel valve and clean the fuel strainer.
 Flush out the tank and reinstall the fuel valve.
 Install the fuel tank.

Connect the fuel tube.
 Install the seat/rear fender.

FUEL TANK

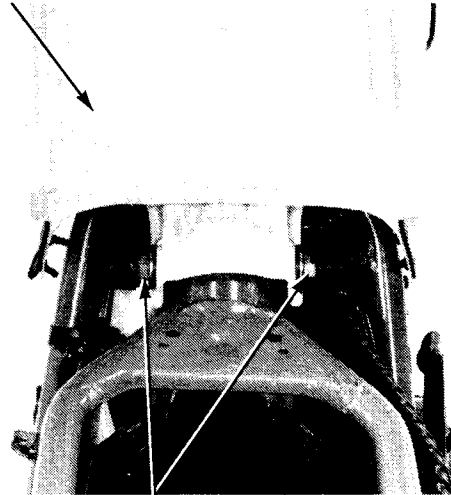

TANK MOUNT BOLTS

CAUTION:

Do not overtighten the fuel valve mounting nut. Excessive torque may damage the fuel tank.

NOTE:

After assembly, make sure there are no fuel leaks.

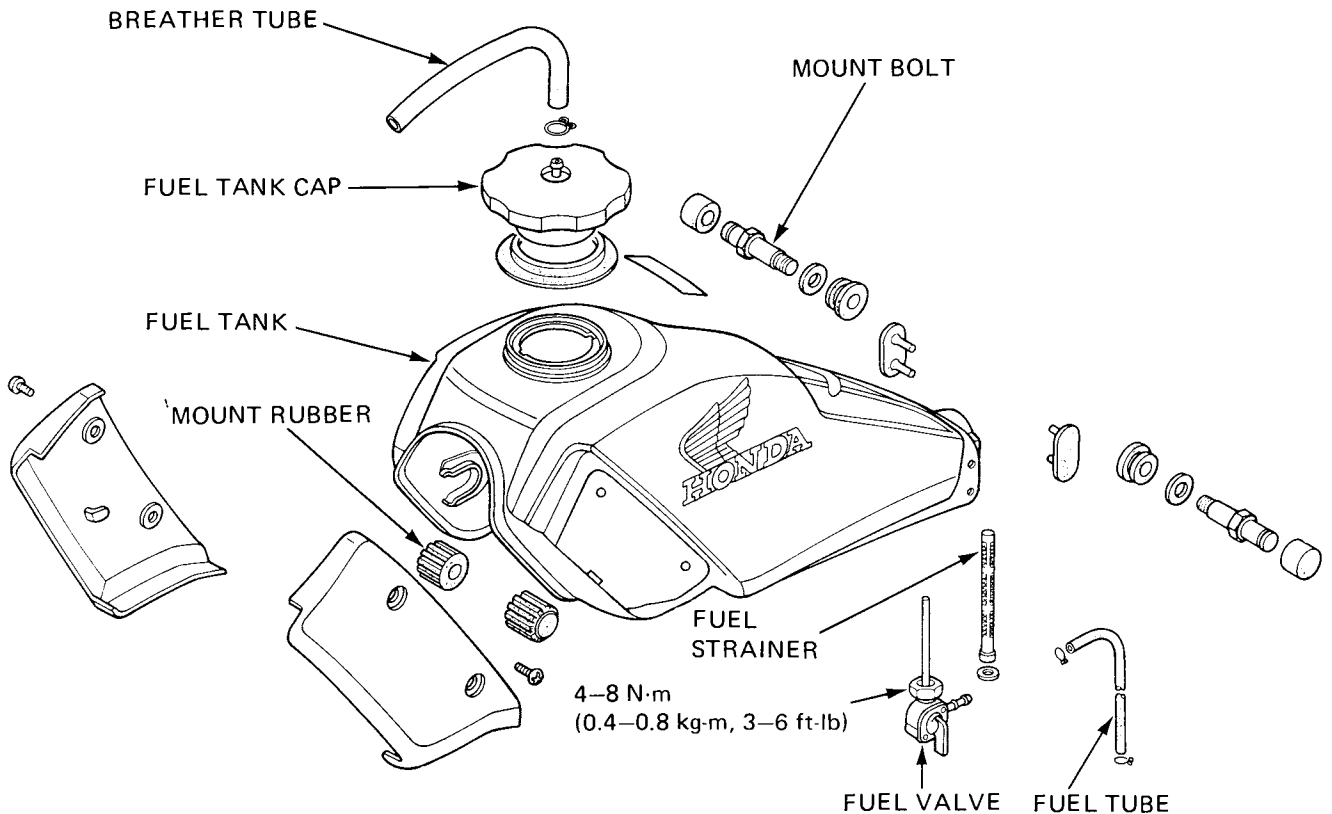

AIR CLEANER CASE

Remove the seat/rear fender.
Loosen the connecting tube band at the air cleaner case.
Loosen the inlet tube band.
Remove the air cleaner case mount bolt and remove the air cleaner case.
For air cleaner element service, see page 3-3.

MOUNT BOLT

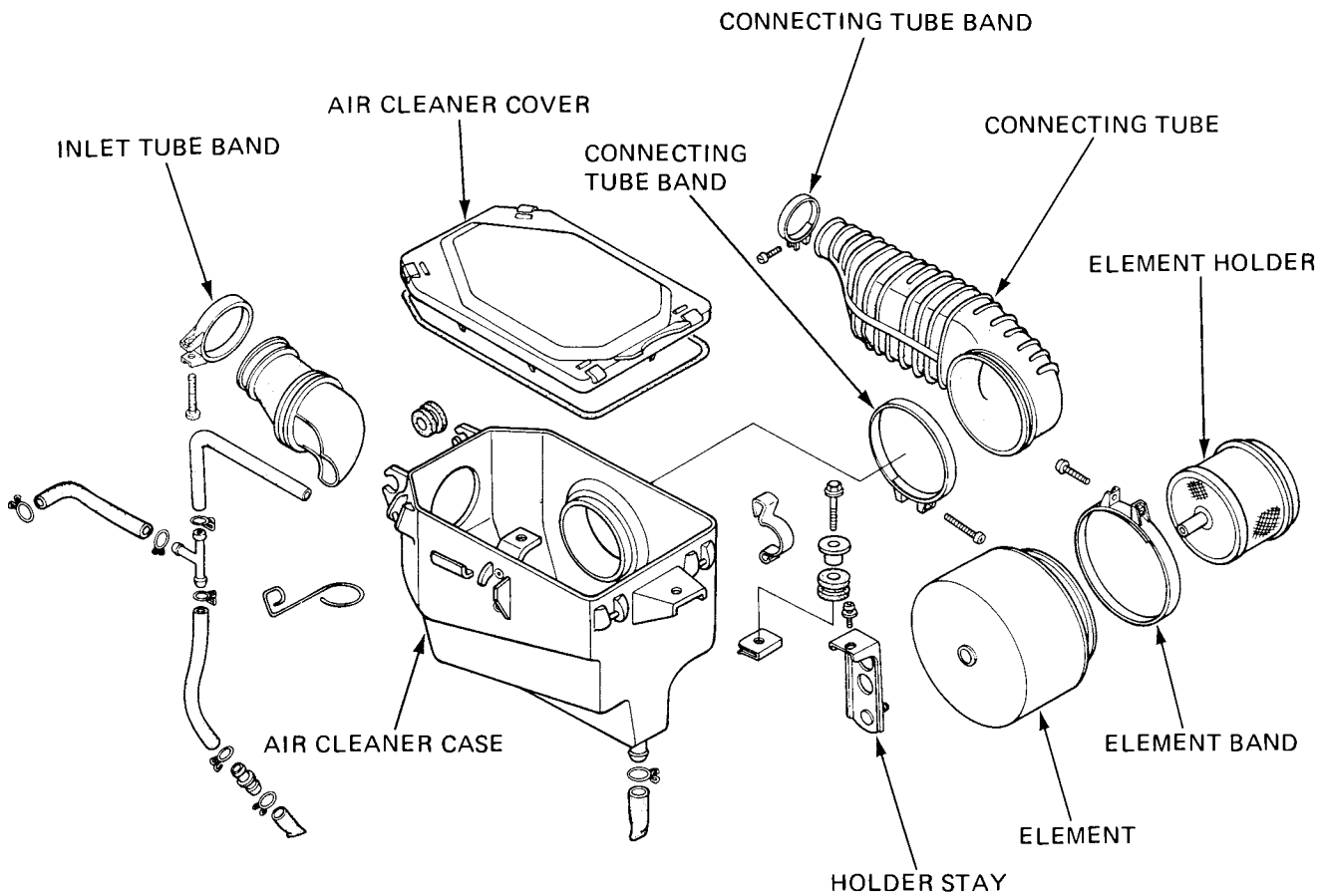
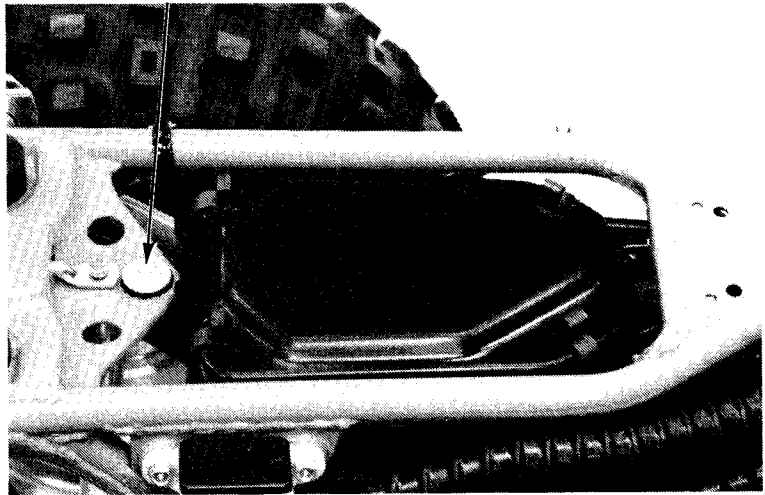

CRANKCASE BREATHER

Route the crankcase breather tube as shown.

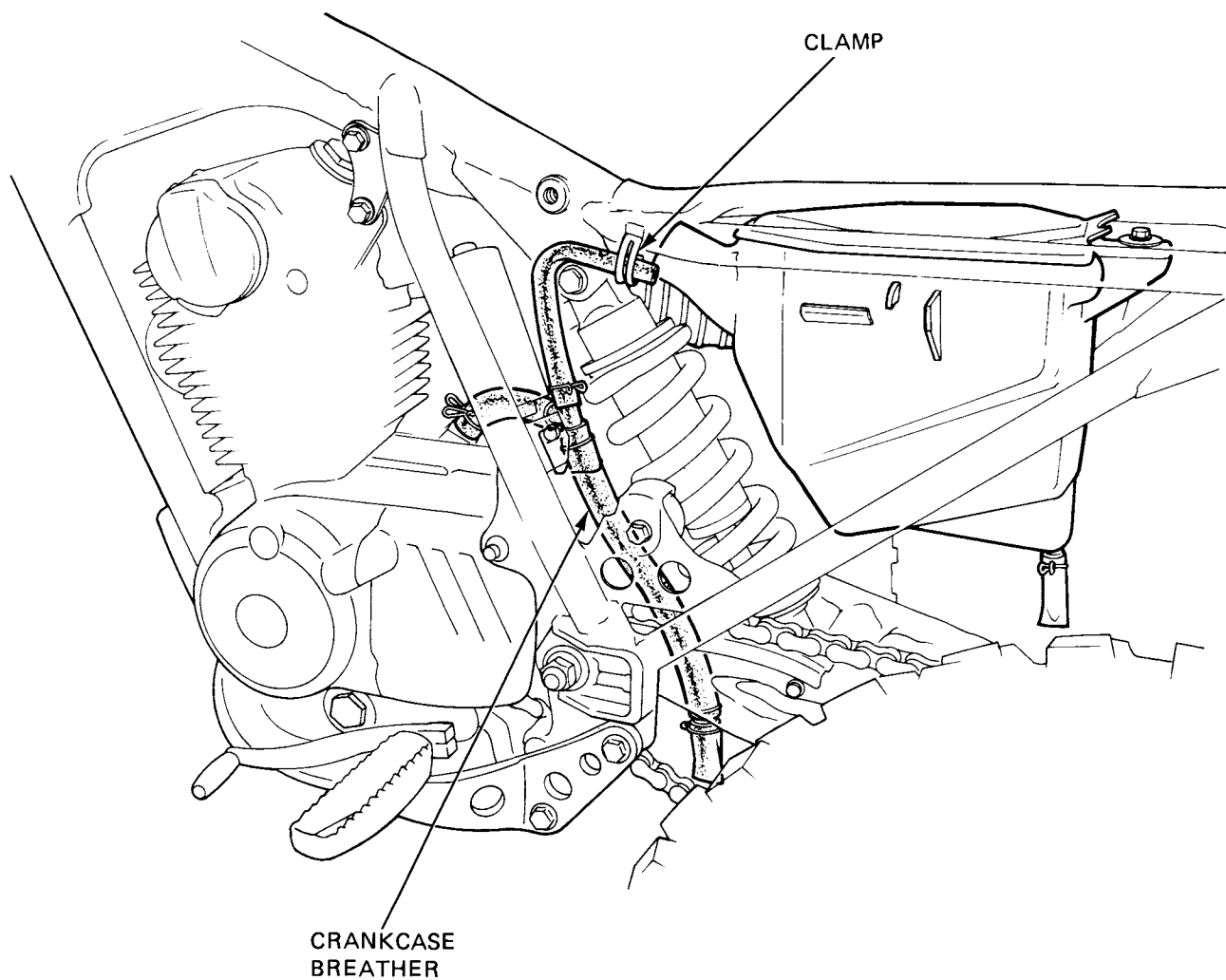

CARBURETOR REMOVAL

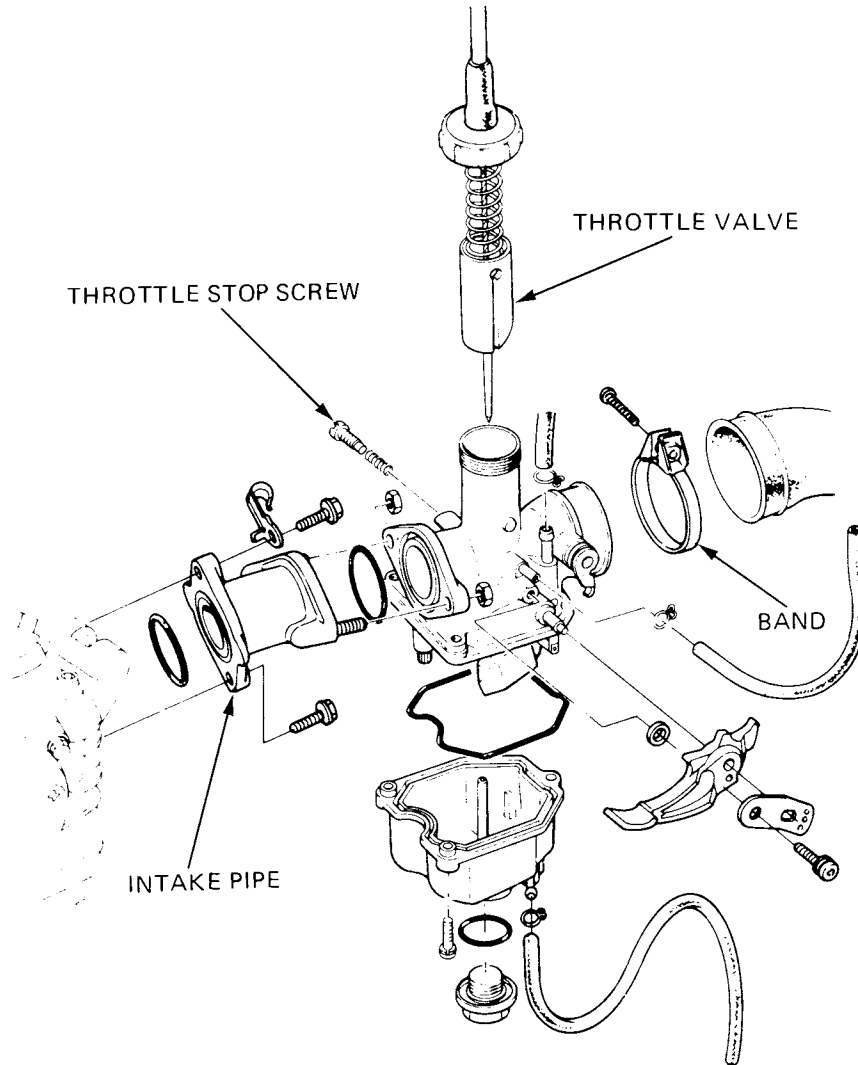

- Remove the seat/rear fender.
- Turn the fuel valve off.
- Loosen the carburetor drain screw and drain the carburetor.
- Remove the fuel tank.
- Remove the carburetor top.
- Loosen the connecting tube band.
- Remove the attaching nuts and remove the carburetor.

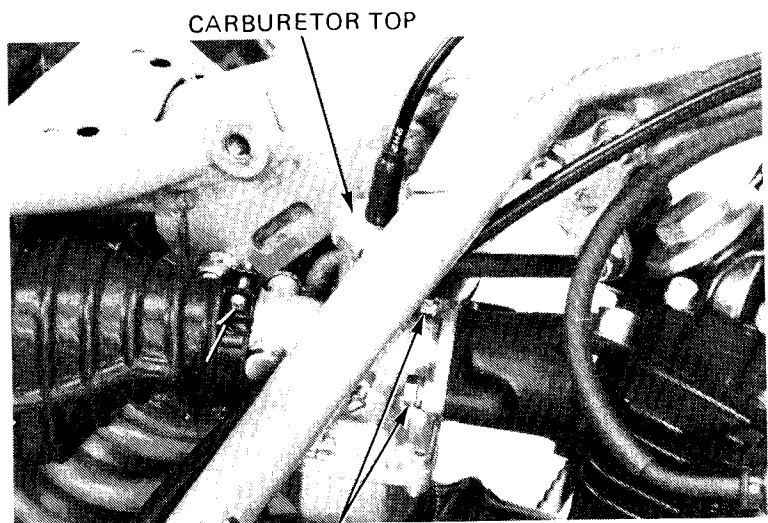

THROTTLE VALVE DISASSEMBLY

Remove the throttle cable from the throttle valve while depressing the throttle valve spring.

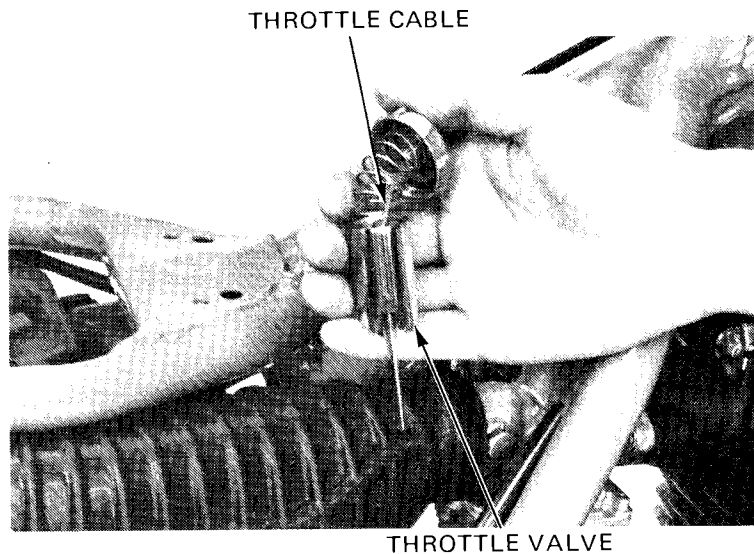

Remove the needle clip retainer.
Remove the jet needle and needle clip.
Inspect the throttle valve and jet needle surface for dirt, scratches or wear. Replace if necessary.

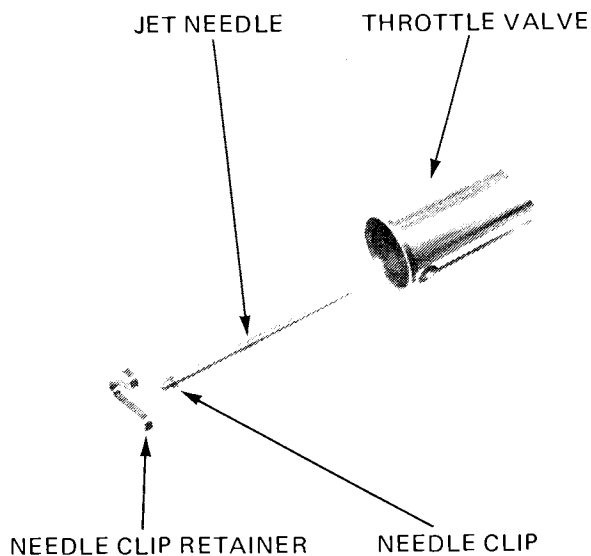

FLOAT, FLOAT VALVE AND JETS

Remove the float chamber body.
Remove the float arm pin with pliers.
Remove the float and float valve.

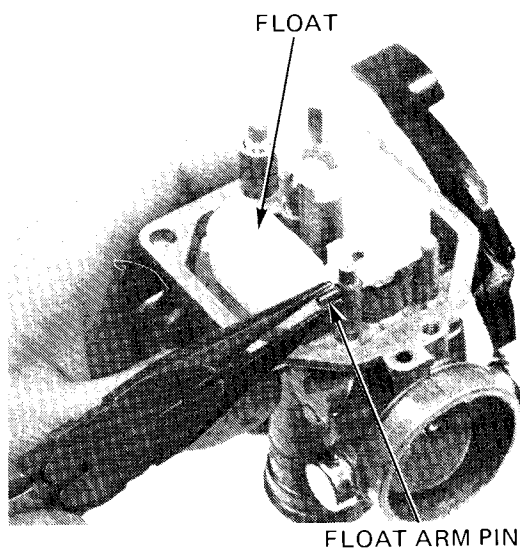

FUEL SYSTEM

Inspect the float valve and float valve seat for wear or damage; such as pitting or grooving.

Remove the main jet, needle jet holder and needle jet.

Remove the slow jet.

Before removing the pilot screw, record the number of turns in to make the screw seat lightly. The pilot screw can be returned to its original factory pre-set position.

Remove the pilot screw.

Blow open all jets and carburetor body openings with compressed air.

Inspect the pilot screw, needle jet, needle jet holder and main jet.

Check each part for wear or damage.

CARBURETOR ASSEMBLY

Carburetor assembly is essentially the reverse order of disassembly.

Install the float valve into the float valve seat.

Install the float and insert the float arm pin.

NOTE:

- Use new O-rings whenever the carburetor is reassembled.
- Handle all jets and needles with care; they can easily be scored or scratched. Set the pilot screw to the position recorded during disassembly.

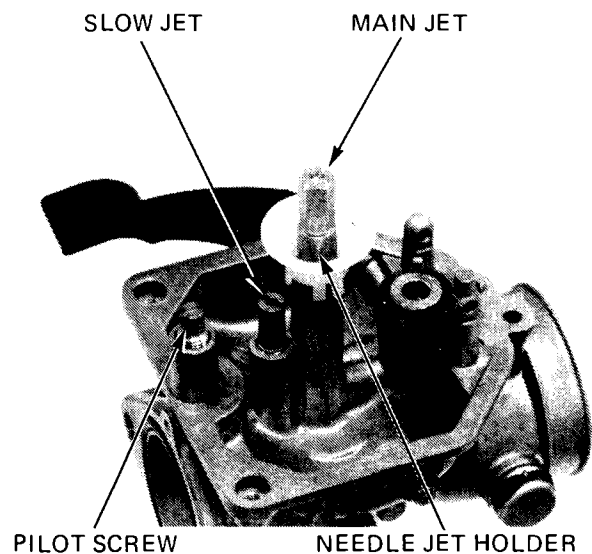
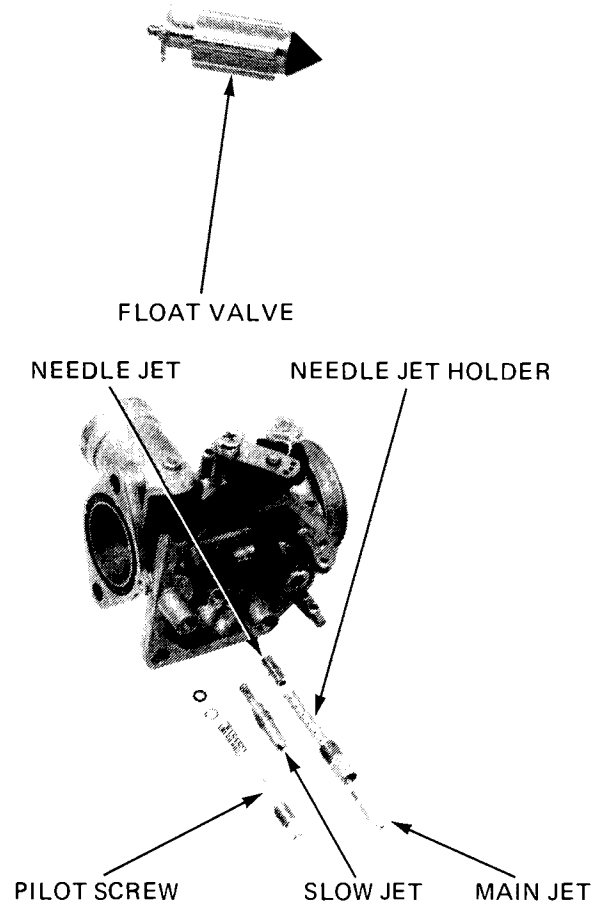

FLOAT LEVEL ADJUSTMENT

Measure the float level with a float level gauge as shown.

FLOAT LEVEL: 14.0 mm (0.55 in)

To adjust the float level, bend the float arm carefully until the float tip just contacts the float valve.

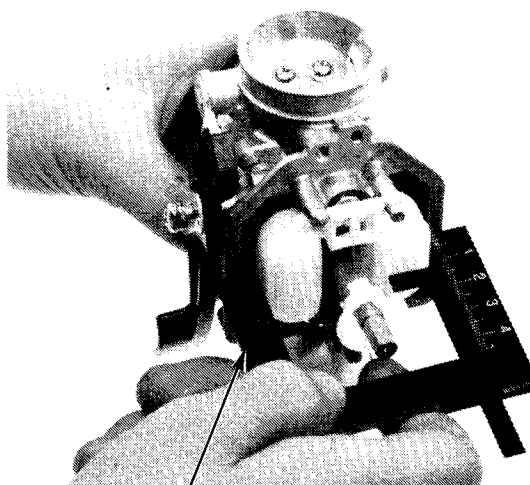

FLOAT LEVEL GAUGE
07401-0010000

THROTTLE VALVE ASSEMBLY

Install the needle clip on the jet needle.

STANDARD SETTING POSITION:

1983	3rd groove
After 1983	4th groove

Install the jet needle into the throttle valve and clamp it with the needle clip retainer.

NOTE:

Install the needle clip retainer on the lower position of the throttle valve.

Install the throttle cable and spring.

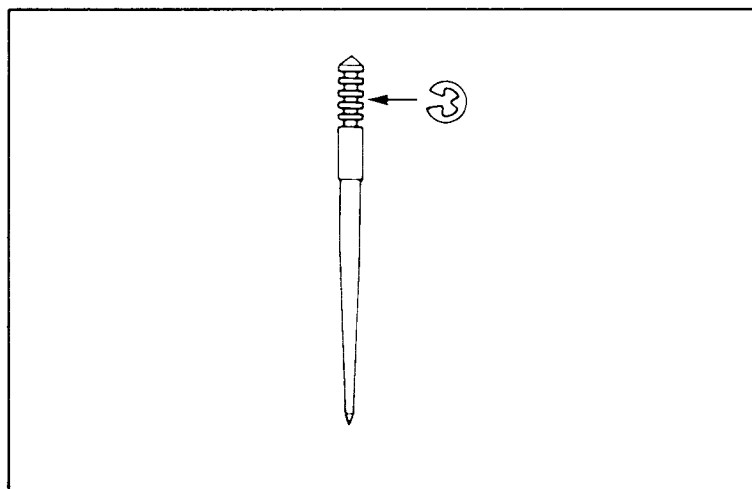

CARBURETOR INSTALLATION

Carburetor installation is essentially the reverse of removal.

NOTE:

- When installing the throttle valve, align the throttle valve groove with the throttle stop screw.
- After installing the carburetor, perform the following adjustments:
Throttle lever free play (page 3-7).
Carburetor pilot screw adjustment (page 4-10) if the carburetor was overhauled.

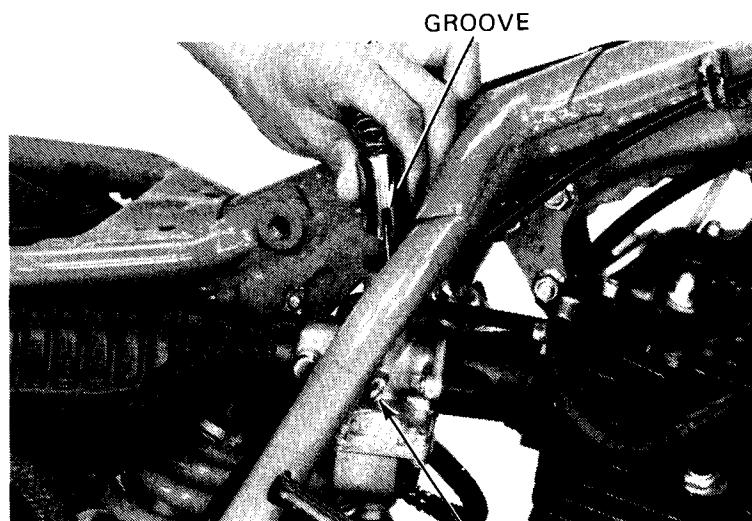

THROTTLE STOP SCREW

FUEL SYSTEM

PILOT SCREW ADJUSTMENT

IDLE DROP PROCEDURE

NOTE:

The pilot screw is factory pre-set. Adjustment is not necessary unless the carburetor is overhauled.

CAUTION:

Damage to the pilot screw seat will occur if the pilot screw is tightened against the seat.

Turn the pilot screw clockwise until it seats lightly and back it out 1-3/4 turns.

Warm the engine up to operating temperature. Stop the engine and connect a tachometer. Start the engine and adjust the idle speed with the throttle stop screw.

IDLE SPEED: 1,300 ± 100 rpm

Turn the pilot screw clockwise slowly until the engine stops, and then back it out 1 turn. Start the engine and readjust the idle speed with the throttle stop screw, if necessary.

HIGH ALTITUDE ADJUSTMENT

1983

The carburetor must be adjusted for high altitude riding (above 2,000 m/6,500 ft).

STANDARD SETTING: 2,000 m (6,500 ft) max.

**HIGH ALTITUDE SETTING:
1,500 m (5,000 ft) min.**

High altitude carburetor adjustment is performed as follows:

Turn the fuel valve OFF.

Place the carburetor drain tube into a suitable container. Turn the carburetor drain screw counter-clockwise.

Remove the float chamber.

Remove the standard main jet and install the high altitude main jet.

Turn the pilot screw clockwise the amount shown in the chart.

Reinstall the float chamber.

Make sure the drain screw is turned fully clockwise and turn the fuel valve ON.

Start the engine and adjust the idle speed and pilot screw.

CAUTION:

Sustained operation below 1,500 m (5,000 ft) with the high altitude settings may cause engine overheating and engine damage. Install the standard main jet and return the pilot screw to the factory preset position when riding below 1,500 m (5,000 ft).

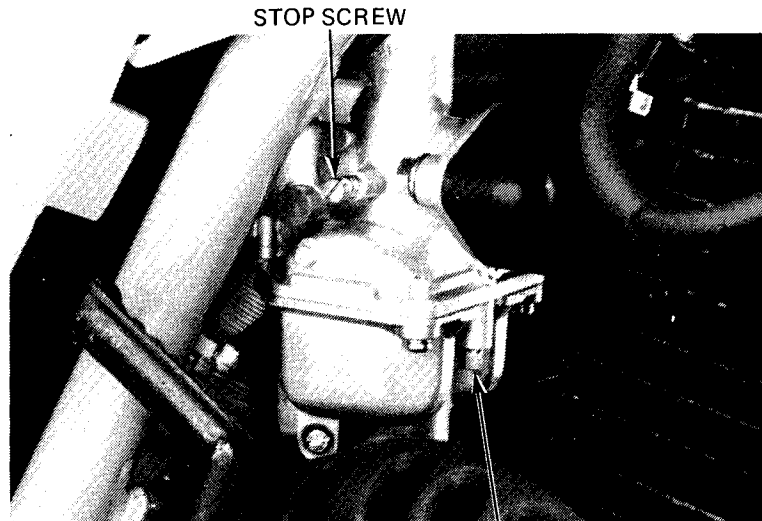

PILOT SCREW

SPECIFICATIONS

	Standard (2,000 m/6,500 ft max.)	High altitude (1,500 m/5,000 fr min.)
Identification number	1983 PD62A	←
	After 1983 PD62B	
Main jet	1983 #110	1983 #105
	After 1983 #108	After 1983 #102
Pilot screw opening	Factory preset	1984 1/4 turn clockwise
		After 1983 turn clockwise

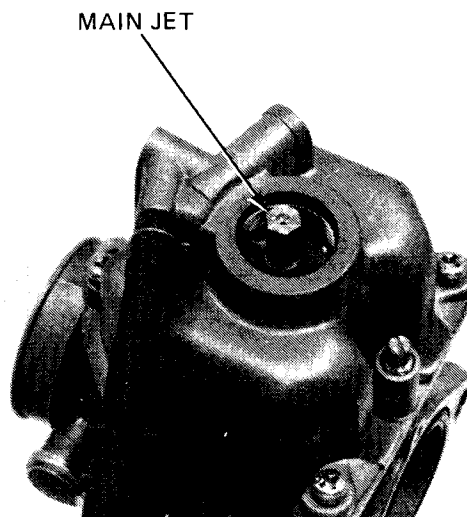

M E M O

ENGINE REMOVAL/INSTALLATION

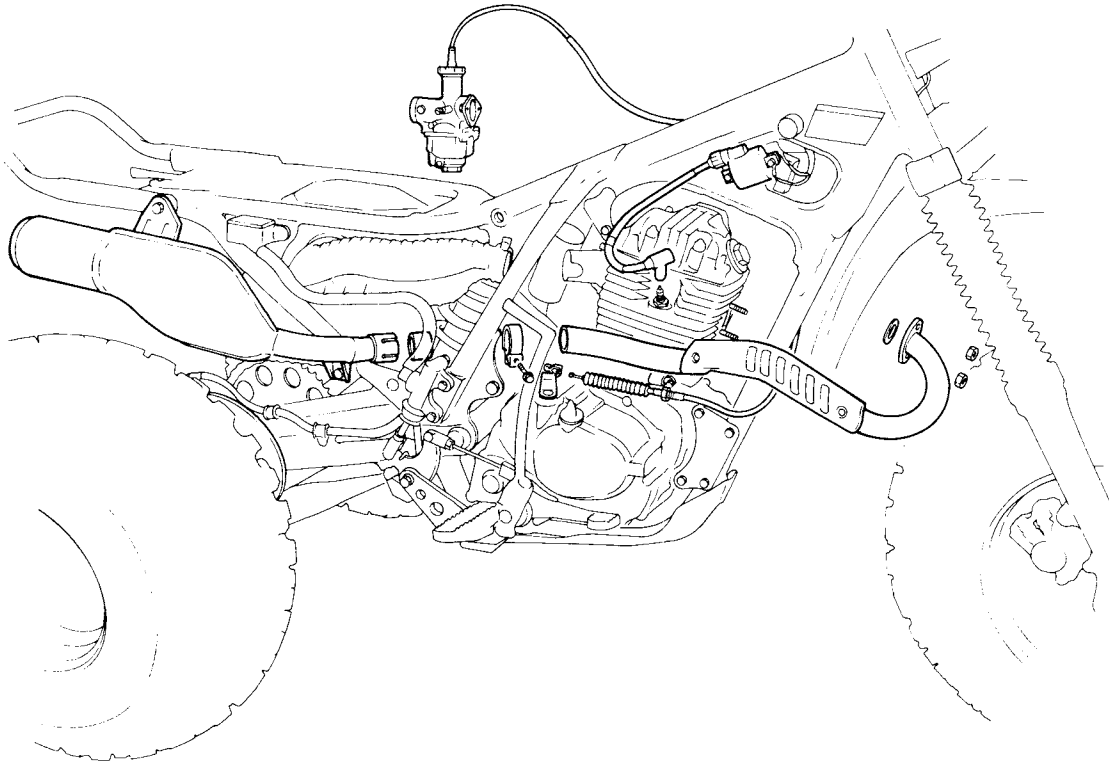

40–48 N·m (4.0–4.8 kg·m,
29–35 ft·lb)

23–27 N·m (2.3–2.7 kg·m,
17–20 ft·lb)

45–53 N·m
(4.5–5.3 kg·m,
33–38 ft·lb)

23–27 N·m (2.3–2.7 kg·m,
17–20 ft·lb)

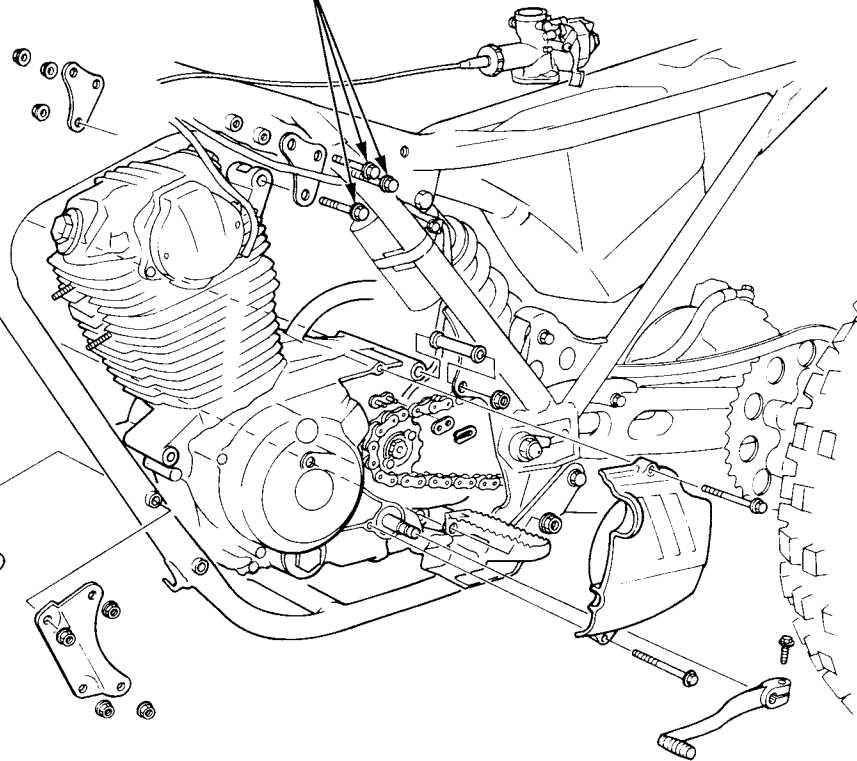

5. ENGINE REMOVAL/INSTALLATION

SERVICE INFORMATION	5-1
ENGINE REMOVAL	5-2
ENGINE INSTALLATION	5-3

SERVICE INFORMATION

GENERAL

- This section covers removal and installation of the engine.
- Operations requiring engine removal:
 - Cylinder head Section 6
 - Cylinder and piston Section 7
 - Crankshaft, transmission and kick starter Section 10
- Upon reassembly, make sure that no exhaust gas leaks past the exhaust pipe connection.

SPECIFICATIONS

Engine dry weight	28 kg (62 lb)
Engine oil capacity	1.2 liters (1.3 US qt, 1.1 Imp qt) after disassembly 1.0 liters (1.1 US qt, 0.9 Imp qt) after draining

TORQUE VALUES

Engine hanger bolts 8 mm	23-27 N·m (2.3-2.7 kg·m, 17-20 ft·lb)
10 mm	40-48 N·m (4.0-4.8 kg·m, 29-35 ft·lb)
Bottom engine mounting bolt	45-53 N·m (4.5-5.3 kg·m, 33-38 ft·lb)

ENGINE REMOVAL/INSTALLATION

ENGINE REMOVAL

Drain the crankcase.
Remove the seat/rear fender.
Remove the fuel tank (page 4-3).
Remove the carburetor (page 4-6).
Disconnect the spark plug cap.
Remove the exhaust pipe.
Disconnect the clutch cable.
Remove the right footpeg bracket.
Disconnect the brake rod from the brake arm.

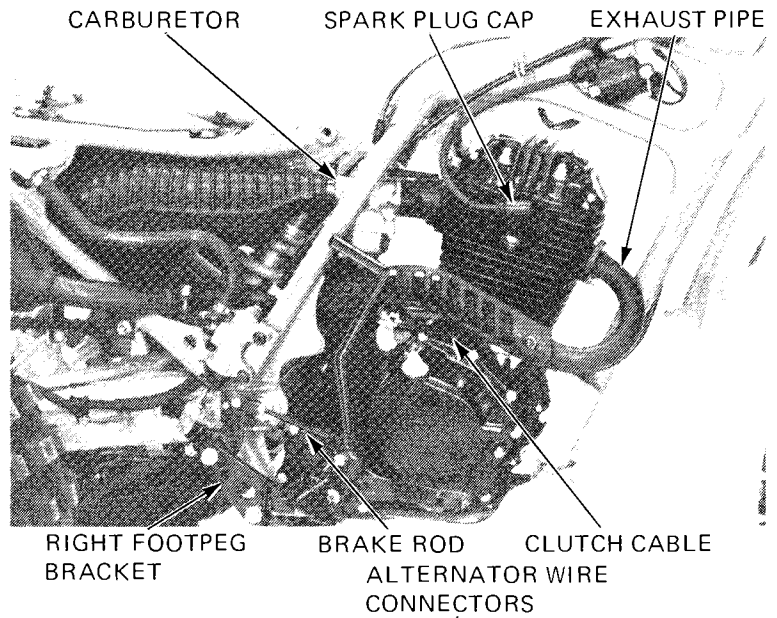

Disconnect the pulse generator wire connectors.
Disconnect the alternator wire connectors and free the wire from the clamps.

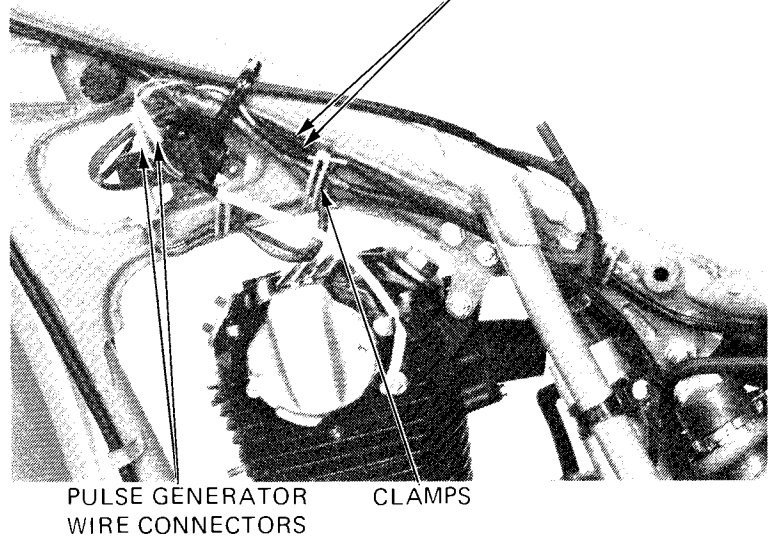

Remove the left footpeg bracket.
Remove the gearshift pedal and drive sprocket cover.
Remove the drive chain.
Disconnect the crankcase breather tube.
Remove the engine hanger bolts and mounting bolt, and remove the engine from the frame.

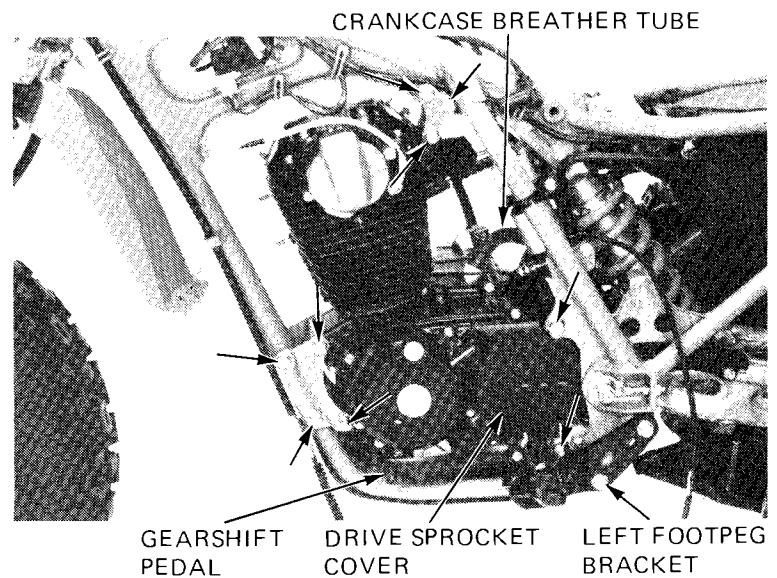

ENGINE INSTALLATION

Place the engine in the frame.
Install the engine hanger bolts and tighten them to the specified torque values in a crisscross pattern in 2–3 steps.

NOTE:

- Install the upper 10 mm bolt with the two collars.
- Use the correct bolts in their proper positions.
- Route the wires and cables properly (page 1-7).

Connect the crankcase breather tube.
Install the drive chain.
Install the drive sprocket cover and gearshift pedal.
Install the left footpeg bracket.

Route the alternator wire properly and secure it with clamps.
Connect the alternator wire connectors and pulse generator wire connectors.

Connect the brake rod to the brake arm.
Install the right footpeg bracket.
Connect the clutch cable.
Install the exhaust pipe and tighten the nuts.
Attach the spark plug cap.
Install the carburetor and fuel tank (section 4).
Install the seat/rear fender.
Fill the crankcase with the recommended oil (page 2-2).

NOTE:

- After installing the engine, perform the following inspections and adjustments:
- Engine oil level (page 2-2).
 - Throttle lever free play (page 3-7).
 - Clutch lever free play (page 3-15).
 - Drive chain free play (page 3-9).
 - Check the performance of the electrical system.

8 mm BOLTS 23–27 N·m
(2.3–2.7 kg·m, 17–20 ft·lb)

10 mm BOLT 40–48 N·m
(4.0–4.8 kg·m, 29–35 ft·lb)

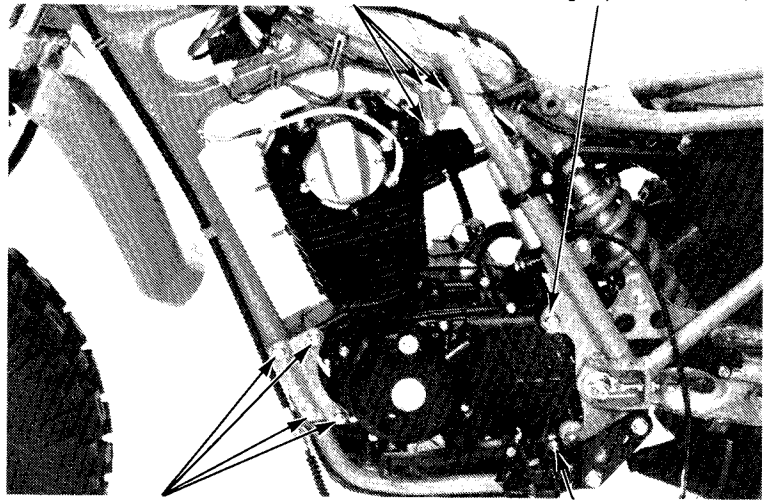

8 mm BOLTS 23–27 N·m
(2.3–2.7 kg·m, 17–20 ft·lb)

10 mm BOLT 45–53 N·m
(4.5–5.3 kg·m, 33–38 ft·lb)

CONNECTORS

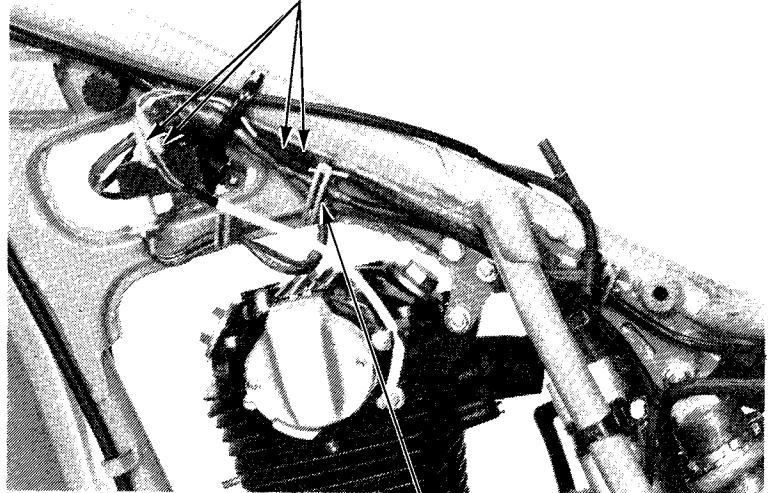

CLAMPS

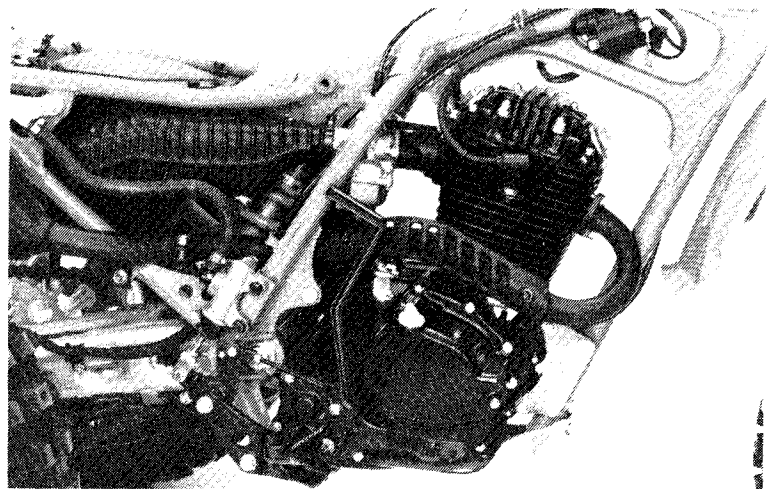

CYLINDER HEAD/VALVES

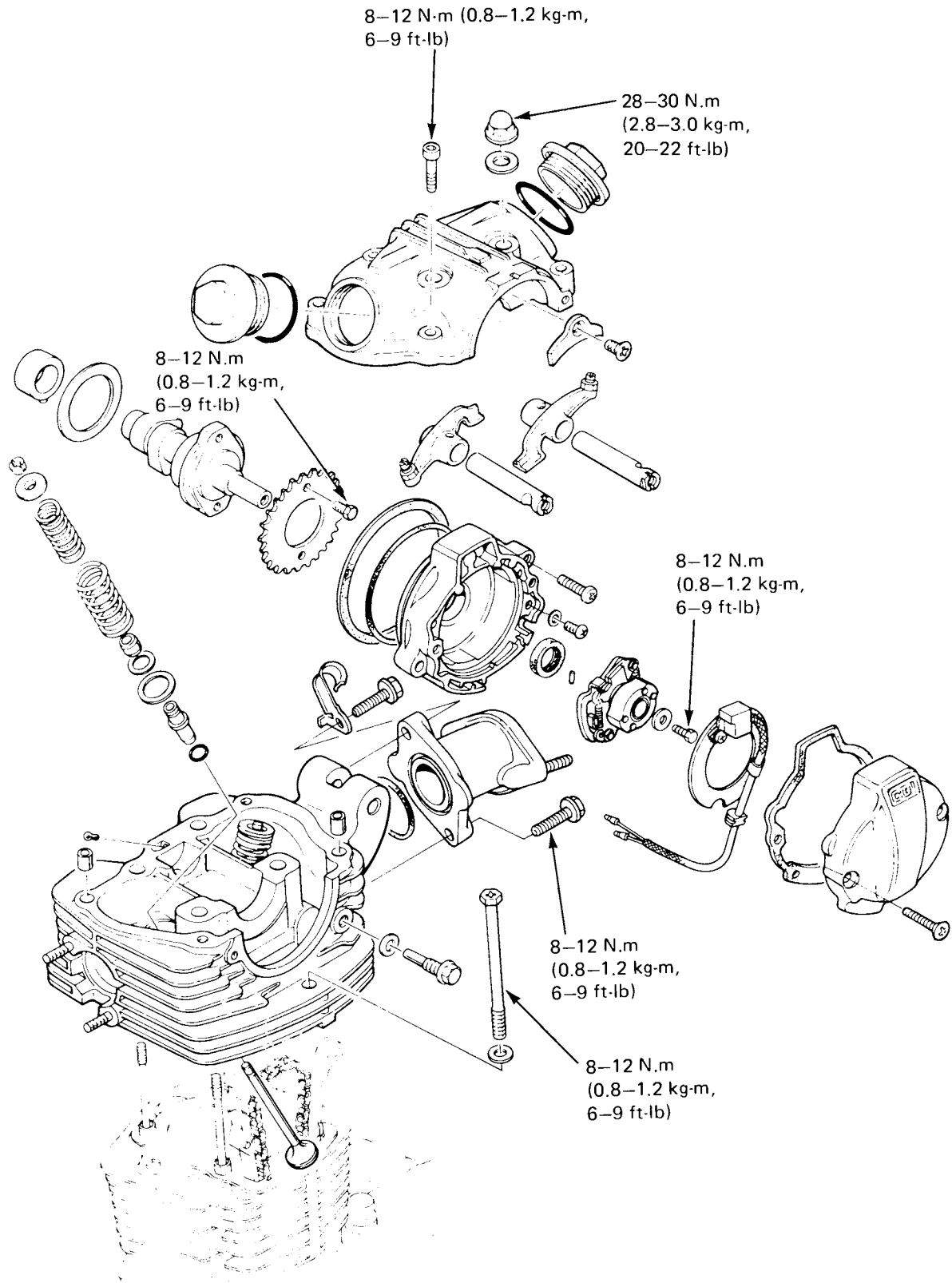

6. CYLINDER HEAD/VALVES

SERVICE INFORMATION	6-1
TROUBLESHOOTING	6-3
CAMSHAFT REMOVAL	6-4
CYLINDER HEAD REMOVAL	6-6
CYLINDER HEAD DISASSEMBLY	6-9
VALVE SEAT INSPECTION/REFACING	6-12
CYLINDER HEAD ASSEMBLY	6-15
CYLINDER HEAD INSTALLATION	6-16
CAMSHAFT INSTALLATION	6-19

SERVICE INFORMATION

6

GENERAL

- This section covers maintenance of the cylinder head, valves, camshaft and rocker arms.
- The engine must be removed to service the cylinder head and valves.
- The pulse generator and camshaft can be removed with the engine in the frame.
- Camshaft lubrication oil is fed to the cylinder head through an oil control orifice in the engine case. Be sure this orifice is not clogged and that the O-rings and dowel pins are in place before installing the cylinder head.
- Before assembly, apply molybdenum disulfide grease to the camshaft bearings to provide initial lubrication.
- Pour clean engine oil into the oil pockets in the cylinder head to lubricate the cam.

SPECIFICATIONS

ITEM			STANDARD	SERVICE LIMIT
Compression			1,128 kPa (11.5 kg/cm ² , 164 psi)	—
Camshaft	Cam height	IN	32.357–32.517 mm (1.2739–1.2802 in)	32.057 mm (1.2621 in)
		EX	32.041–32.201 mm (1.2615–1.2678 in)	31.821 mm (1.2528 in)
	Journal O.D.	R	19.967–19.980 mm (0.7861–0.7866 in)	19.90 mm (0.783 in)
		L	33.959–33.975 mm (1.3370–1.3376 in)	33.90 mm (1.335 in)
Cylinder head	Bearing I.D.	L	34.000–34.025 mm (1.3386–1.3396 in)	34.05 mm (1.341 in)
	Warpage		—	0.10 mm (0.004 in)
Camshaft bushing	I.D.		20.005–20.026 mm (0.7876–0.7884 in)	20.05 mm (0.789 in)
Rocker arm	I.D.		12.000–12.018 mm (0.4724–0.4731 in)	12.05 mm (0.474 in)
Rocker arm shaft	O.D.		11.977–11.995 mm (0.4715–0.4722 in)	11.93 mm (0.470 in)
Rocker arm-to-shaft clearance			0.005–0.041 mm (0.0002–0.0016 in)	0.08 mm (0.003 in)
Valve spring	Free length	Inner	39.4 mm (1.55 in)	35.5 mm (1.40 in)
		Outer	45.5 mm (1.79 in)	41.0 mm (1.61 in)
	Preload	Inner	83.0 ± 0.6 kg/33.7 mm (183.0 ± 1.3 lb/1.33 in)	—
		Outer	21.0 ± 1.5 kg/38.4 mm (46.3 ± 3.3 lb/1.51 in)	—
Valve, Valve guide	Stem O.D.	IN	5.450–5.465 mm (0.2146–0.2152 in)	5.42 mm (0.213 in)
		EX	5.430–5.445 mm (0.2138–0.2144 in)	5.40 mm (0.213 in)
	Guide I.D.	IN	5.475–5.485 mm (0.2156–0.2159 in)	5.50 mm (0.217 in)
		EX	5.475–5.485 mm (0.2156–0.2159 in)	5.50 mm (0.217 in)
	Stem-to-guide clearance	IN	0.010–0.035 mm (0.0004–0.0014 in)	0.12 mm (0.005 in)
		EX	0.030–0.055 mm (0.0012–0.0022 in)	0.14 mm (0.006 in)
Valve face width			1.7 mm (0.07 in)	2.0 mm (0.08 in)
Valve seat width			1.2 mm (0.05 in)	1.5 mm (0.06 in)

CYLINDER HEAD/VALVES

TORQUE VALUES

Cylinder head	28–30 N·m (2.8–3.0 kg-m, 20–22 ft-lb)
Cam sprocket	8–12 N·m (0.8–1.2 kg-m, 6–9 ft-lb)
Carburetor intake pipe	8–12 N·m (0.8–1.2 kg-m, 6–9 ft-lb)
Pulse rotor	8–12 N·m (0.8–1.2 kg-m, 6–9 ft-lb)
Cylinder head cover	8–12 N·m (0.8–1.2 kg-m, 6–9 ft-lb)

TOOLS

Special

Valve guide reamer 07984–0980000

Common

Valve guide remover, 5.5 mm 07742–0010100 or 07942–3290100
Valve spring compressor 07757–0010000 or 07957–3290001

Optional

Valve seat cutter, 29 mm 07780–0010300
Valve seat cutter, 35 mm 07780–0010400
Valve seat cutter, 30 mm 07780–0014000
Valve seat cutter, 37.5 mm 07780–0014100
Valve seat cutter, 30 mm 07780–0012200
Valve seat cutter, 35 mm 07780–0012300
Valve seat cutter holder 07781–0010100

TROUBLESHOOTING

Engine top-end problems usually affect engine performance. These problems can be diagnosed by a compression test, or by tracing engine noises to the top-end with a sounding rod or stethoscope.

Low compression

1. Valve
 - Incorrect valve adjustment.
 - Burned or bent valves.
 - Incorrect valve timing.
 - Weak valve spring.
2. Cylinder head
 - Leaking or damaged head gasket.
 - Warped or cracked cylinder head.
3. Cylinder and piston (Section 7).

High compression

1. Excessive carbon build-up on piston head or combustion chamber.

Excessive noise

1. Incorrect valve adjustment.
2. Sticking valve or broken valve spring.
3. Damaged or worn rocker arm or camshaft.
4. Worn or damaged cam chain.
5. Worn or damaged cam chain tensioner.
6. Worn cam sprocket teeth.

Poor idling

1. Compression too low.

CAMSHAFT REMOVAL

Remove the pulse generator cover.

PULSE GENERATOR COVER

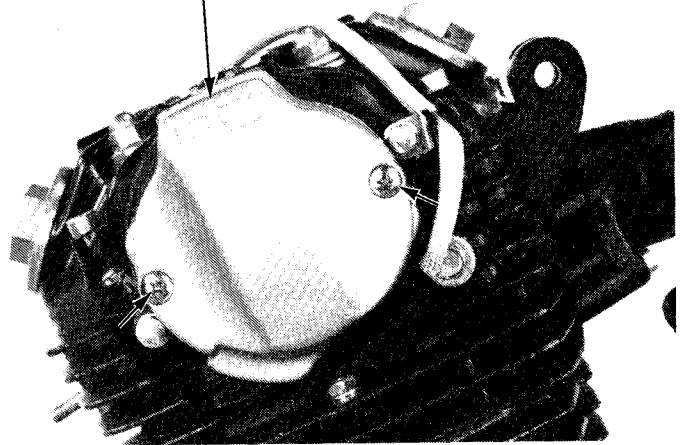

Remove the pulse generator base plate screws, and remove the pulse generator base plate.
Remove the 6 mm bolt and pulse generator rotor.

PULSE GENERATOR
BASE PLATE

6 mm BOLT

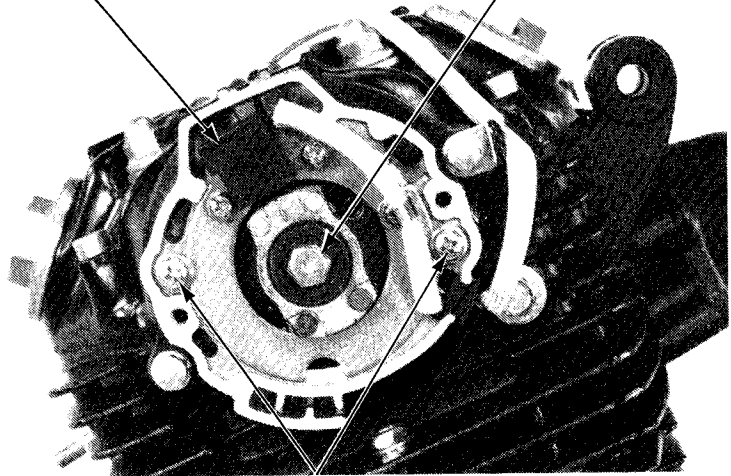

SCREWS

Remove the dowel pin.
Remove the pulse generator base.

DOWEL PIN

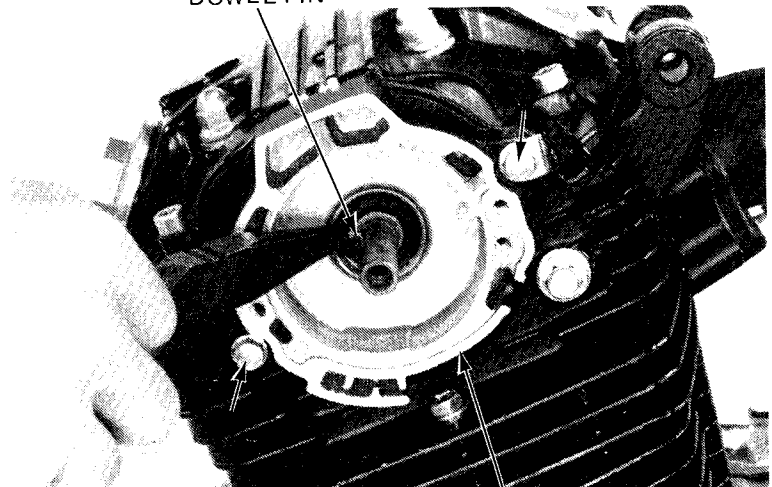

PULSE GENERATOR BASE

Remove the crankshaft hole cap and timing hole cap from the left crankcase cover.
Turn the crankshaft to bring the piston to T.D.C. of the compression stroke.
Remove the cam sprocket bolts, and remove the sprocket.

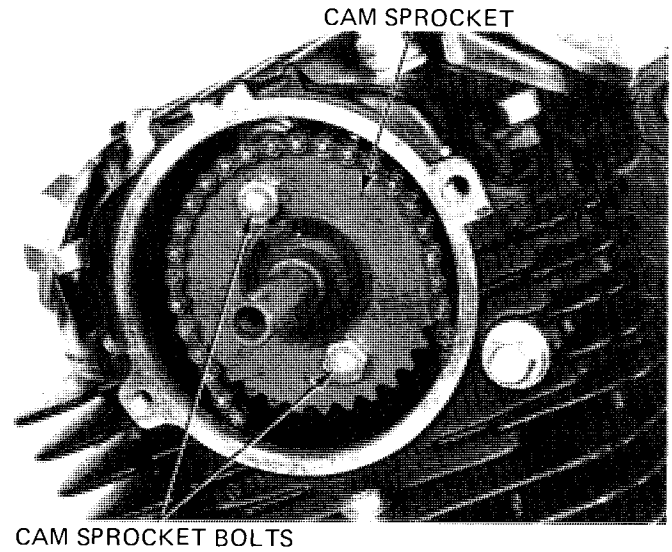

Remove the camshaft.

NOTE:

Suspend the cam chain with a piece of wire to prevent it from falling into the crankcase.

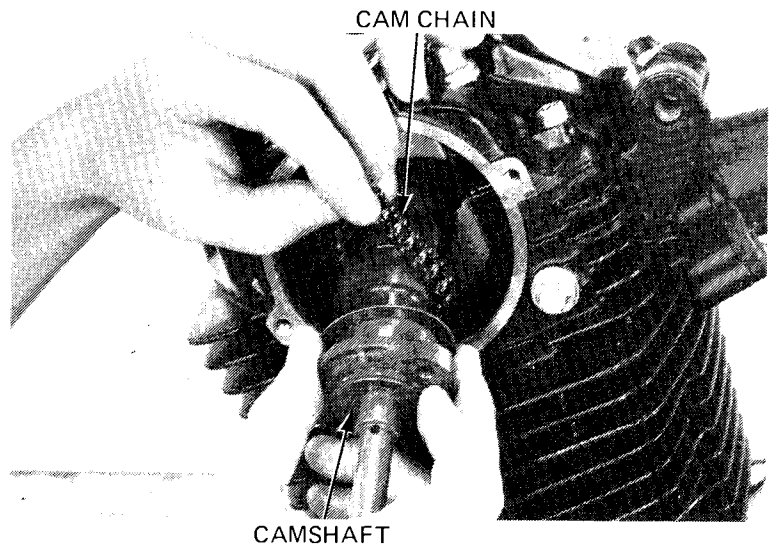

CAMSHAFT INSPECTION

Measure the camshaft journal O.D. with a micrometer.

SERVICE LIMIT:

- RIGHT: 19.90 mm (0.783 in)**
- LEFT: 33.90 mm (1.335 in)**

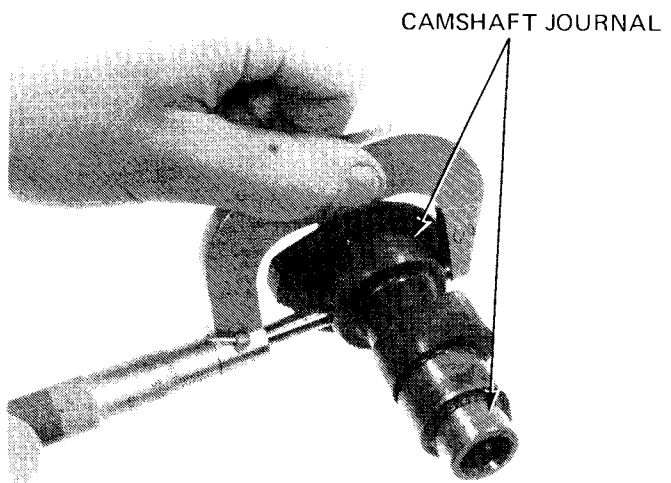

CYLINDER HEAD/VALVES

Using a micrometer, measure each cam height and check it for wear or damage.

SERVICE LIMIT:

INTAKE: 32.057 mm (1.2621 in)

EXHAUST: 31.821 mm (1.2528 in)

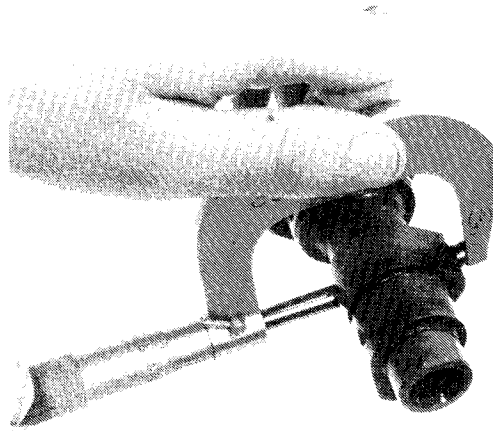

CYLINDER HEAD REMOVAL

Remove the engine from the frame (Section 5).

Remove the 6 mm bolt and socket bolts first and then remove the 8 mm cap nuts attaching the cylinder head cover and cylinder head.

Remove the cylinder head cover.

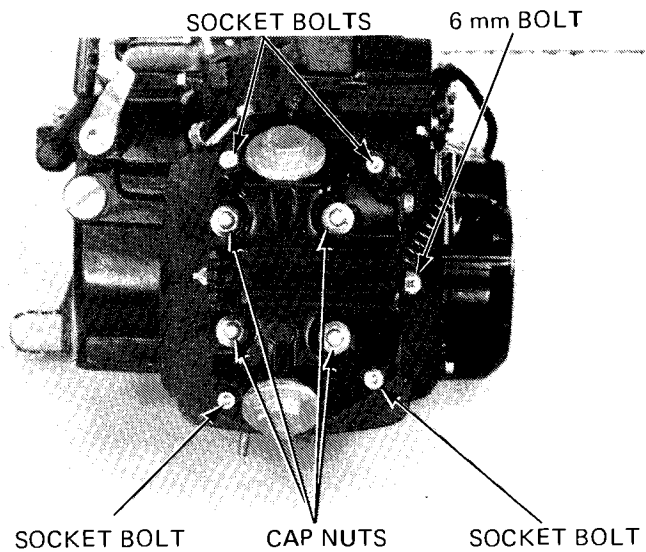

Remove the camshaft bushing.

NOTE:

Do not lose the oil hole plug.

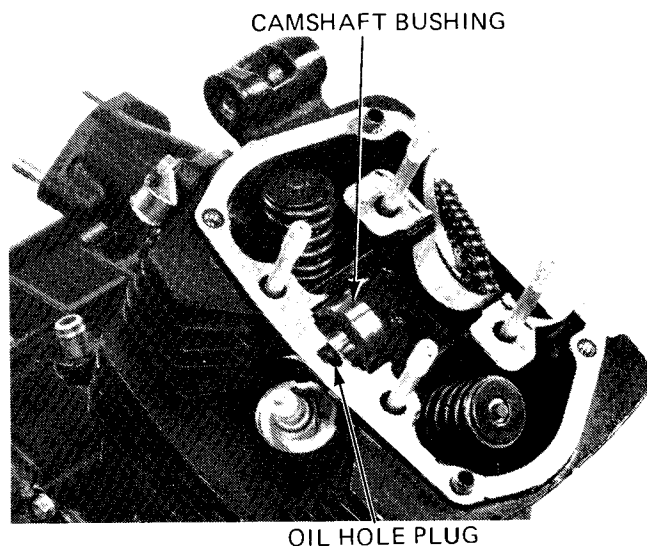

Remove the rocker arm shaft set plate.

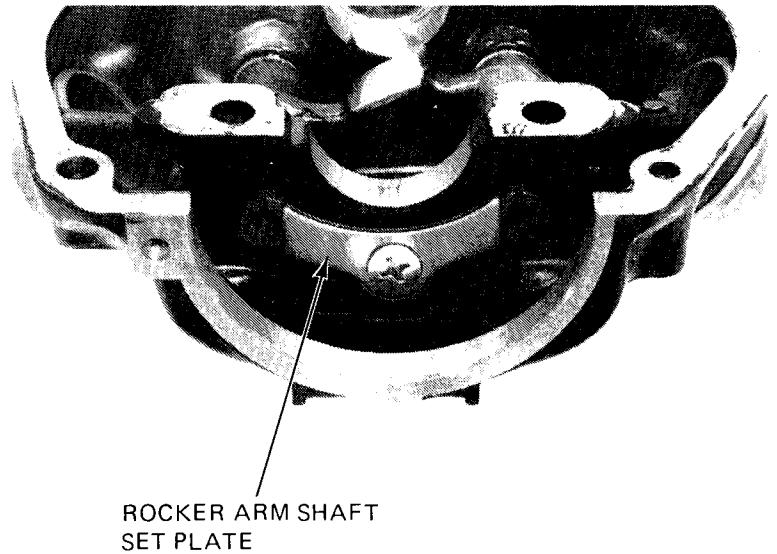

Screw a 6 mm bolt into the threaded end of the rocker arm shaft and pull the shaft out. Remove the rocker arms.

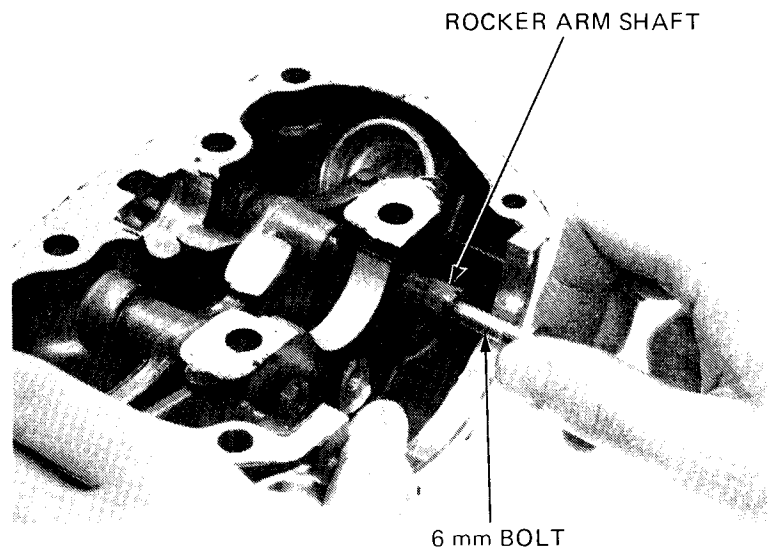

ROCKER ARM INSPECTION

Inspect the rocker arms for damage, wear or clogged oil holes.

NOTE:

If any rocker arms require servicing or replacement, inspect the cam lobes for scoring, chipping or flat spots.

Measure the I.D. of each rocker arm.

SERVICE LIMIT: 12.05 mm (0.474 in)

SERVICE LIMIT:
12.05 mm (0.474 in)

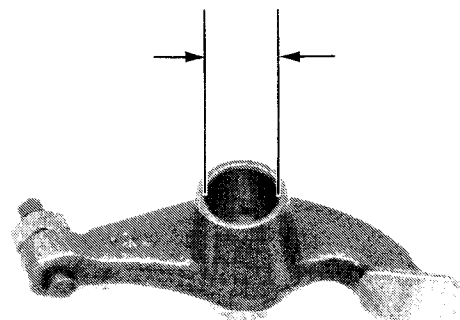

CYLINDER HEAD/VALVES

ROCKER ARM SHAFT INSPECTION

Inspect the rocker arm shafts for wear or damage.
Measure the O.D. with a micrometer.

SERVICE LIMIT: 11.93 mm (0.470 in)

Calculate the rocker arm-to-shaft clearance.

SERVICE LIMIT: 0.08 mm (0.003 in)

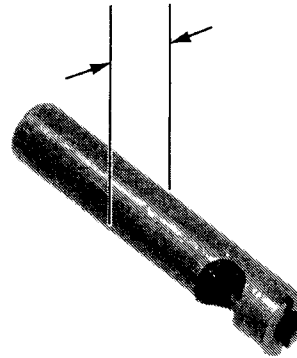

CAMSHAFT BEARING INSPECTION

Install the cylinder head cover with 8 mm nuts.

TORQUE:

28–30 N·m (2.8–3.0 kg·m, 20–22 ft·lb)

Measure the camshaft bearing I.D.

SERVICE LIMIT: 34.05 mm (1.341 in)

Calculate the camshaft-to-bearing clearance.

SERVICE LIMIT: 0.10 mm (0.004 in)

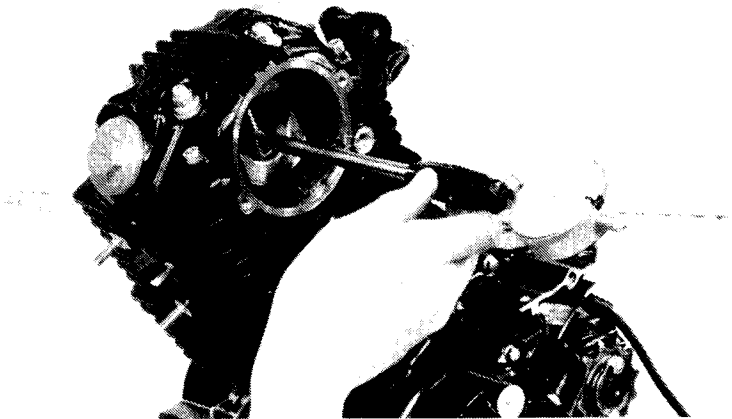

CAMSHAFT BUSHING INSPECTION

Measure the camshaft bushing I.D.

SERVICE LIMIT: 20.05 mm (0.789 in)

Calculate the camshaft bushing-to-camshaft clearance.

SERVICE LIMIT: 0.10 mm (0.004 in)

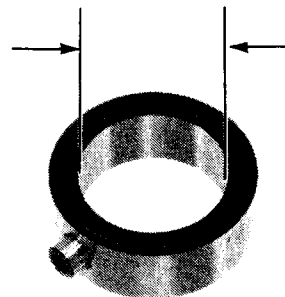

CYLINDER HEAD REMOVAL

Remove the tensioner bolt.
Remove the cylinder head.

CAM CHAIN TENSIONER BOLT

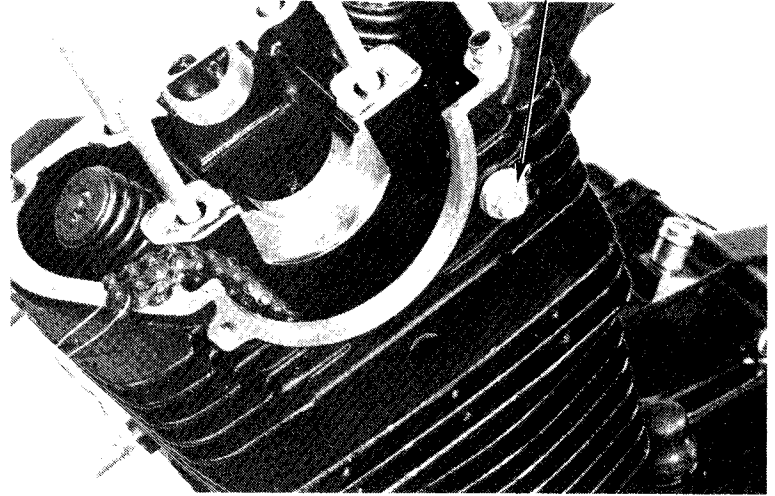

CYLINDER HEAD DISASSEMBLY

Remove the valve cotters, spring retainers and valve springs with a valve spring compressor.

CAUTION:

To prevent loss of tension, do not compress the valve spring more than necessary.

VALVE SPRING COMPRESSOR
07757-0010000 or 07957-3290001

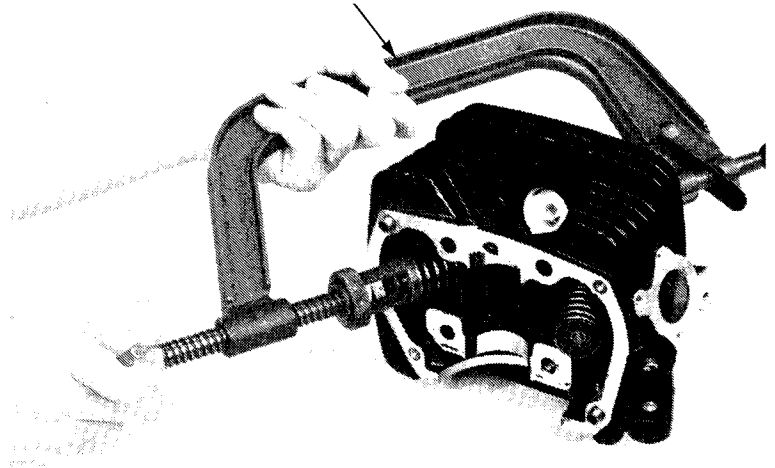

Remove the carbon deposits from the combustion chamber.
Clean off any gasket material from the cylinder head surface.

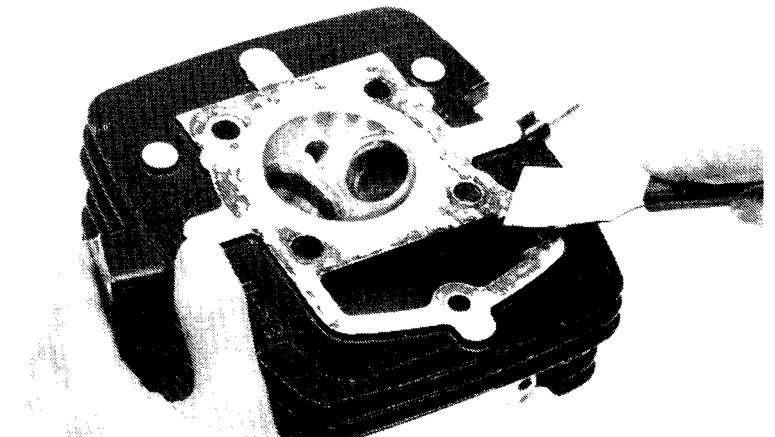

CYLINDER HEAD/VALVES

CYLINDER HEAD INSPECTION

Check the spark plug hole and valve area for cracks. Check the cylinder head for warpage with a straight edge and feeler gauge.

SERVICE LIMIT: 0.10 mm (0.004 in)

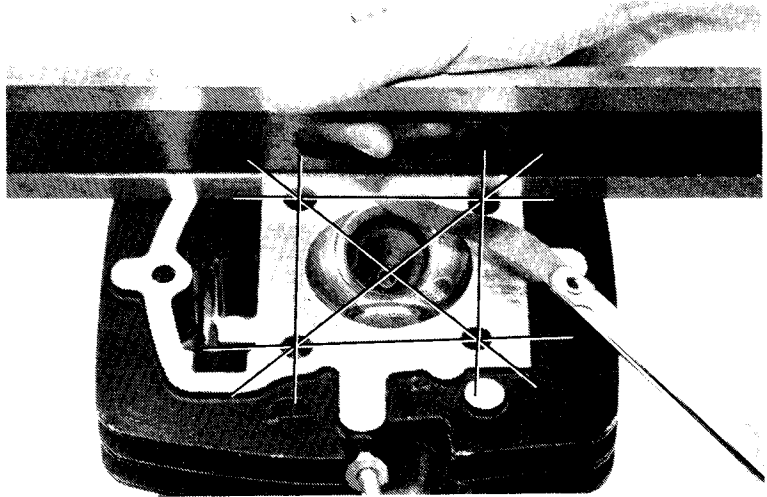

VALVE SPRING INSPECTION

Measure the free length of the inner and outer valve springs.

**SERVICE LIMITS: Inner: 35.5 mm (1.40 in)
Outer: 41.0 mm (1.61 in)**

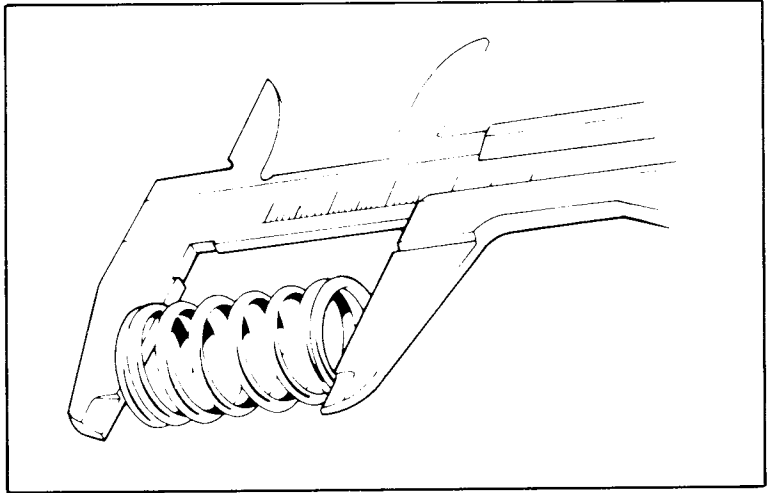

VALVE/VALVE GUIDE INSPECTION

Inspect each valve for trueness, burning, scratches or abnormal stem wear.

Check the valve movement in the guide. Measure and record each valve stem O.D.

**SERVICE LIMITS:
INTAKE: 5.42 mm (0.213 in)
EXHAUST: 5.40 mm (0.213 in)**

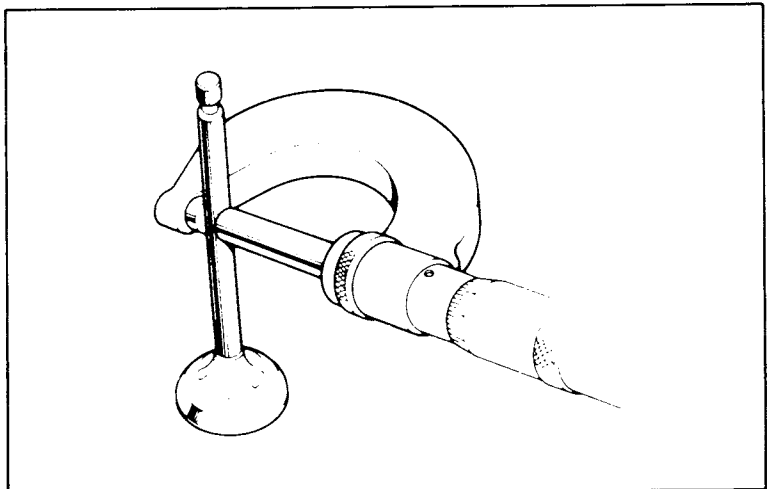

Measure and record the valve guide I.D.

SERVICE LIMIT: IN/EX: 5.50 mm (0.217 in)

NOTE:

Ream the guides to remove any carbon build up before checking the valve guide I.D.

Calculate the stem-to-guide clearance.

SERVICE LIMIT: IN: 0.12 mm (0.005 in)
EX: 0.14 mm (0.006 in)

NOTE:

- If the stem-to-guide clearance exceeds the service limit, determine if a new guide with standard dimensions would bring the clearance within tolerance. If so, replace guides as necessary and ream to fit.
- If the valve guide is replaced, the valve seat must be refaced.

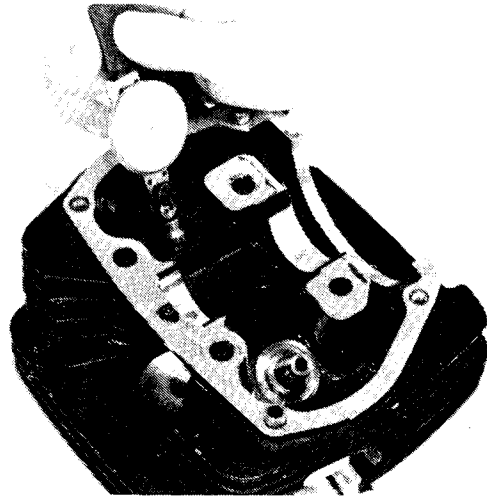

VALVE GUIDE REPLACEMENT

Support the cylinder head and drive out the guide from the valve port with a valve guide remover.

NOTE:

When driving out the guide, do not damage the head.

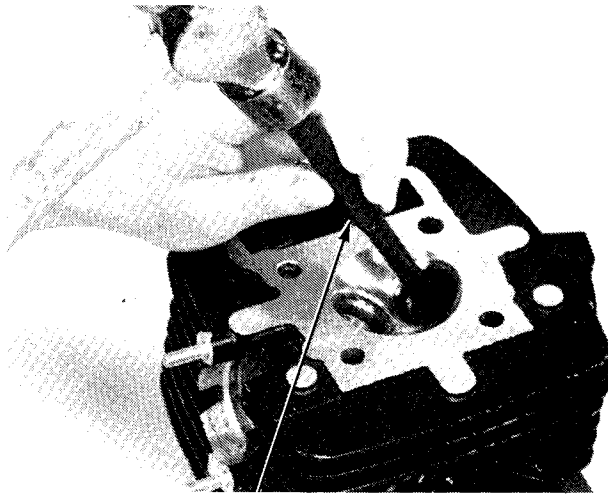

VALVE GUIDE REMOVER, 5.5 mm
 07742-0010100 or 07942-3290100

Install an O-ring on the new valve guide.
 Drive in the guide from the top of the head.

NOTE:

Inspect the valve guide for damage.

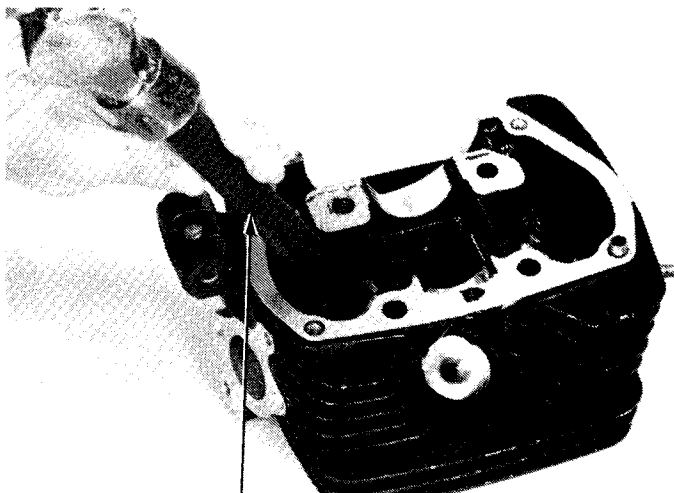

VALVE GUIDE REMOVER, 5.5 mm
 07742-0010100 or 07942-3290100

CYLINDER HEAD/VALVES

Ream the new valve guide after installation.

NOTE:

- Use cutting oil on the reamer during this operation.
- Rotate the reamer in the cutting direction when inserting and removing it.

Clean the cylinder head thoroughly to remove any metal particles.
Reface the valve seat.

VALVE GUIDE REAMER
07984-0980000

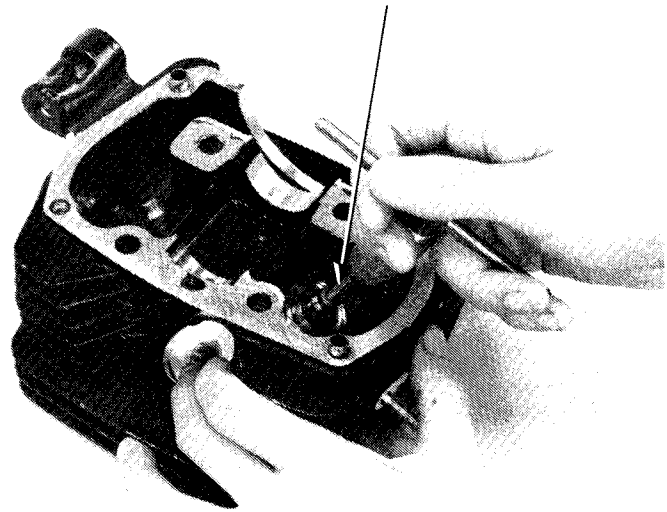

VALVE SEAT INSPECTION/REFACING

Clean all intake and exhaust valves thoroughly to remove carbon deposits.

Apply a light coating of Prussian Blue to each valve seat. Lap each valve and seat using a rubber hose or other hand-lapping tool.
Remove the valves and measure their face contact width.

SERVICE LIMIT: 2.0 mm (0.08 in)

CAUTION:

The valve cannot be ground. If the valve face is burned or badly worn or if it contacts the seat unevenly, replace the valve.

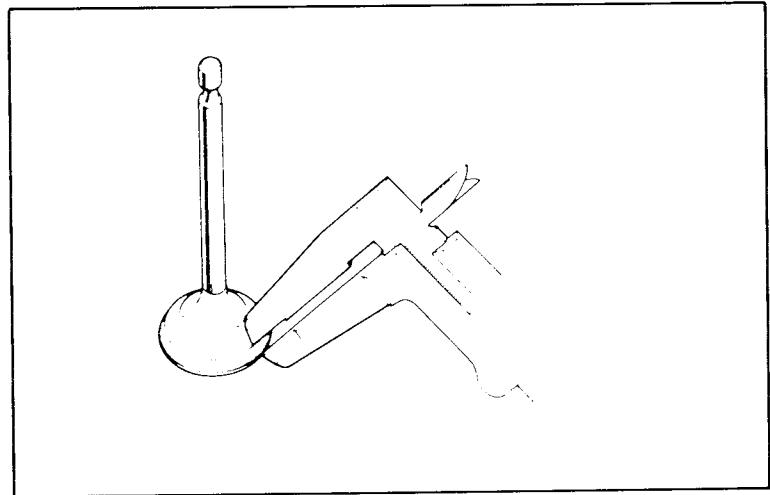

Measure each valve seat width.

SERVICE LIMIT: 1.5 mm (0.06 in)

If the seat is too wide, too narrow, or has low spots, the seat must be refinished to seal properly.

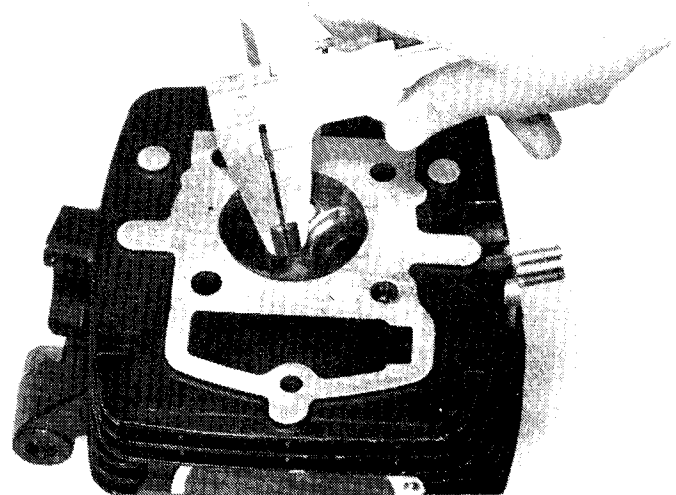

VALVE SEAT GRINDING

Honda valve seat cutters, grinder or equivalent valve seat refacing equipment are recommended to correct a worn valve seat.

Follow the instructions supplied with the Valve Seat Refacing Equipment.

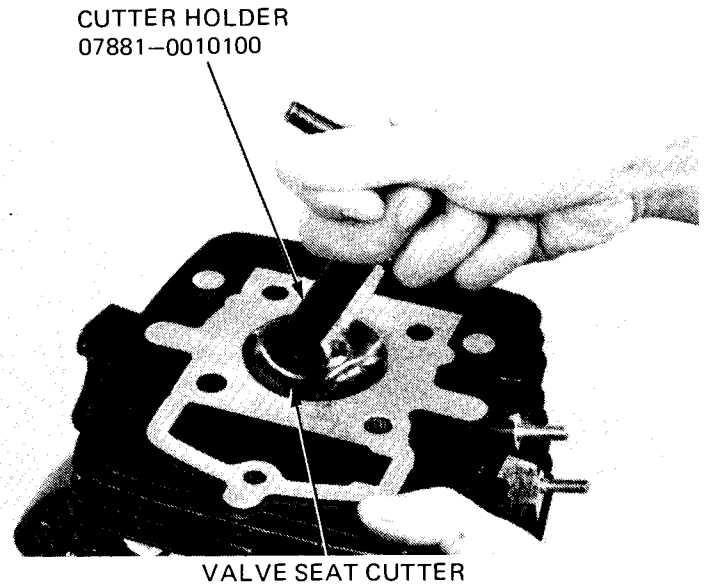

VALVE SEAT CUTTERS

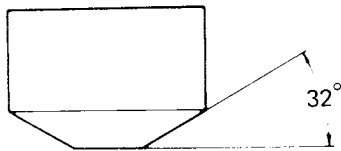

TOOL No.
 IN: 07780-0012300
 EX: 07780-0012200

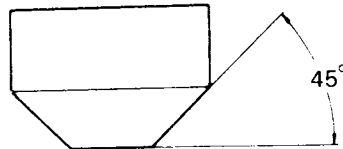

IN: 07780-0010400
 EX: 07780-0010300

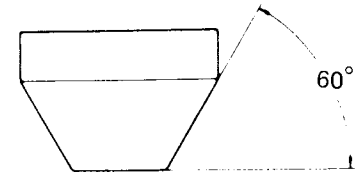

IN: 07780-0014100
 EX: 07780-0014000

VALVE SEAT REFACING

Follow the refacer manufacturer's instructions. Use a 45 degree cutter to remove any roughness or irregularities from the seat.

NOTE:

Reface the seat with a 45 degree cutter when the valve guide is replaced.

Use a 32 degree cutter to remove 1/4 of the existing valve seat material.

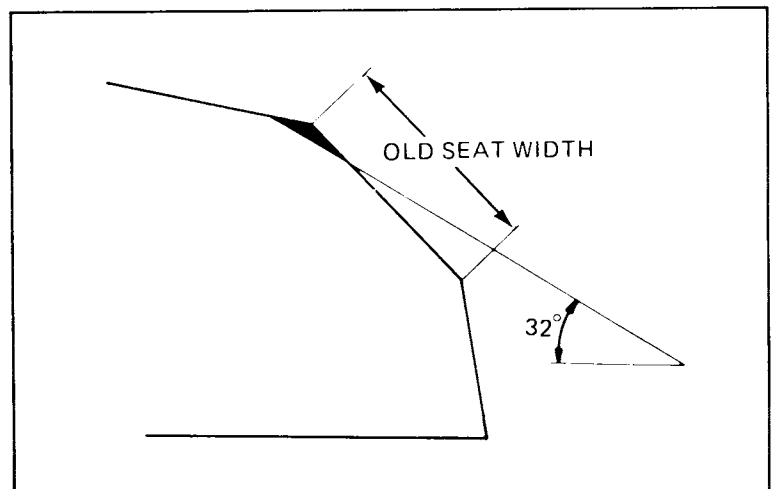

CYLINDER HEAD/VALVES

Use a 60 degree cutter to remove the bottom 1/4 of the old seat. Remove the cutter and inspect the area you have just removed.

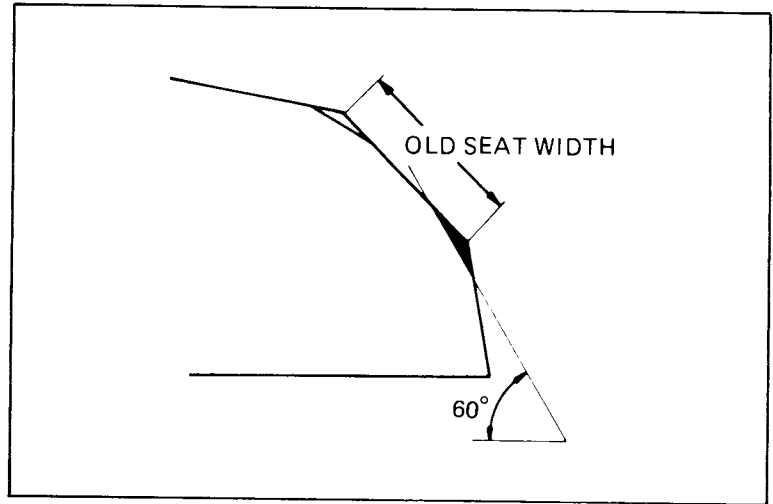

Install a 45 degree finish cutter and cut the seat to the proper width.

NOTE:

Make sure that all pitting and irregularities are removed. Refinish if necessary.

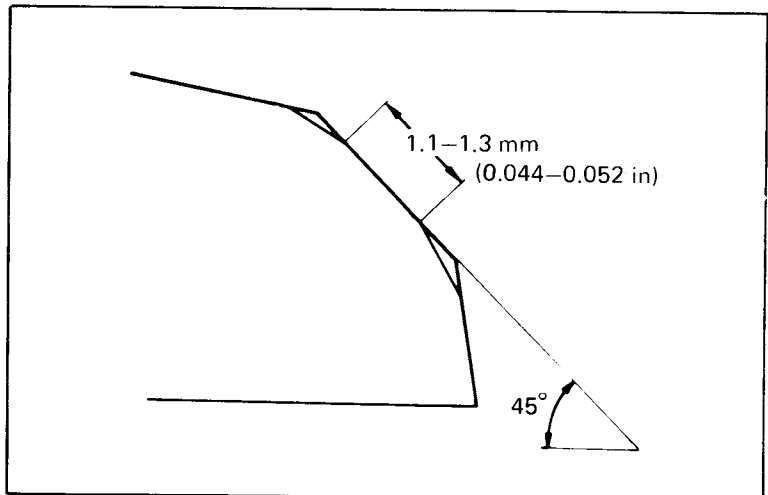

Apply a thin coating of Prussian Blue to the valve seat.

Press the valve through the valve guide and onto the seat to make a clear pattern.

NOTE:

The location of the valve seat in relation to the valve face is very important for good sealing.

If the contact area is too high on the valve, the seat must be lowered using a 32 degree cutter.

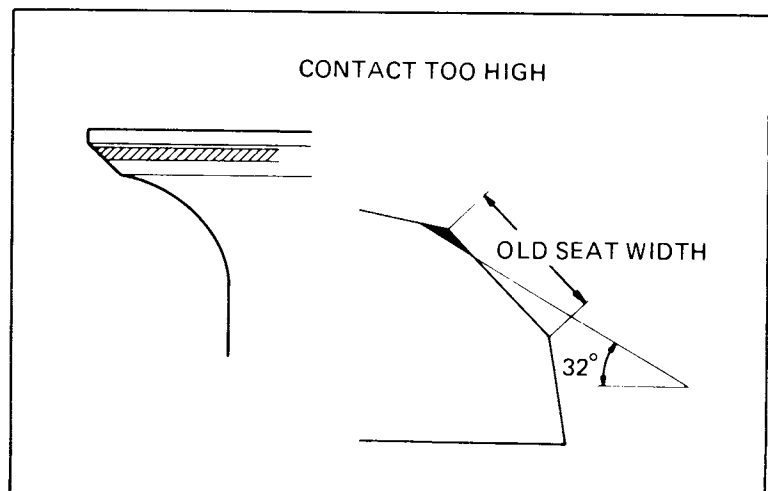

If the contact area is too low on the valve, the seat must be raised using a 60 degree cutter.

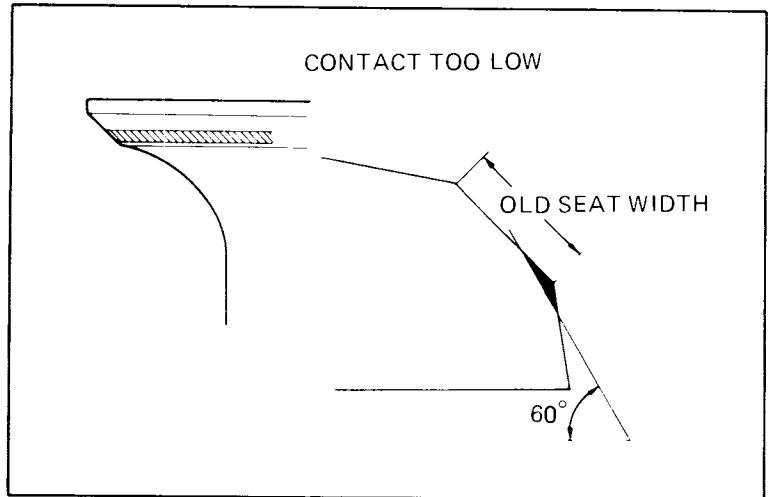

Refinish the seat to specifications, using a 45 degree finish cutter.

After cutting the seat, apply lapping compound to the valve face, and lap the valve using light pressure.

NOTE:

Take care not to allow the compound to enter between the valve stem and guide.

After lapping, wash all residual compound off the cylinder head and valve.

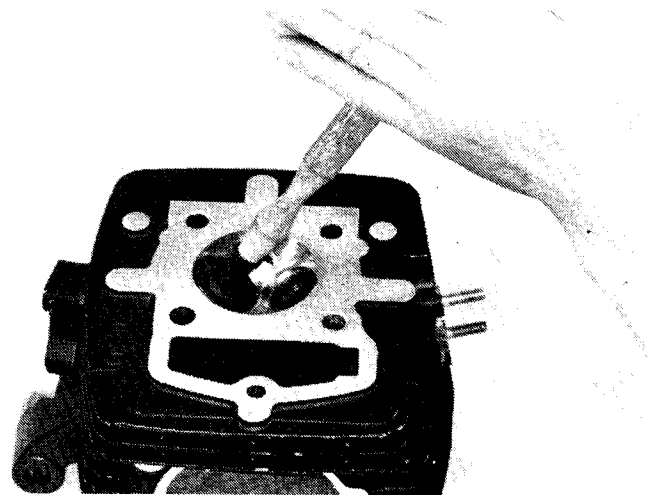

CYLINDER HEAD ASSEMBLY

NOTE:

Install new valve stem seals before assembling.

Lubricate each valve stem with oil.
 Insert the valves into the valve guides.
 Install the valve springs with the tightly wound coils facing the cylinder head.

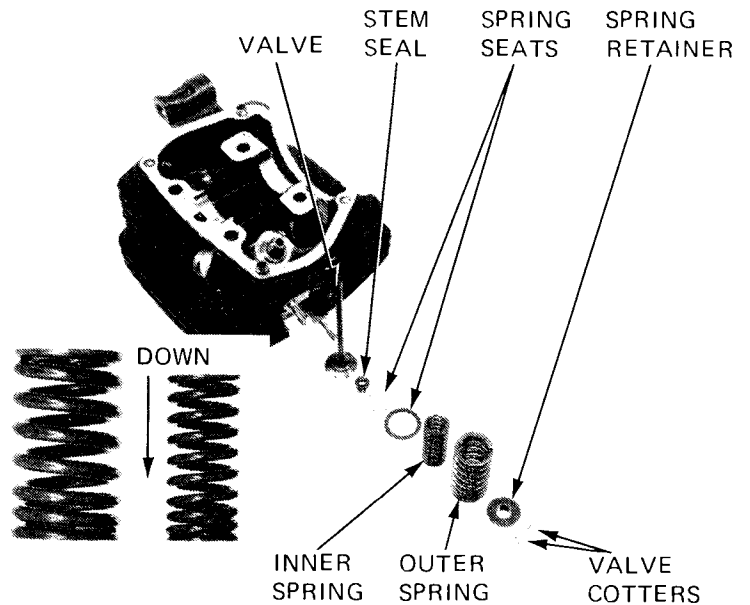

CYLINDER HEAD/VALVES

Install the valve spring retainers.
Install the valve cotters.

CAUTION:

To prevent loss of tension, do not compress the valve spring more than necessary.

VALVE SPRING COMPRESSOR
07757-0010000

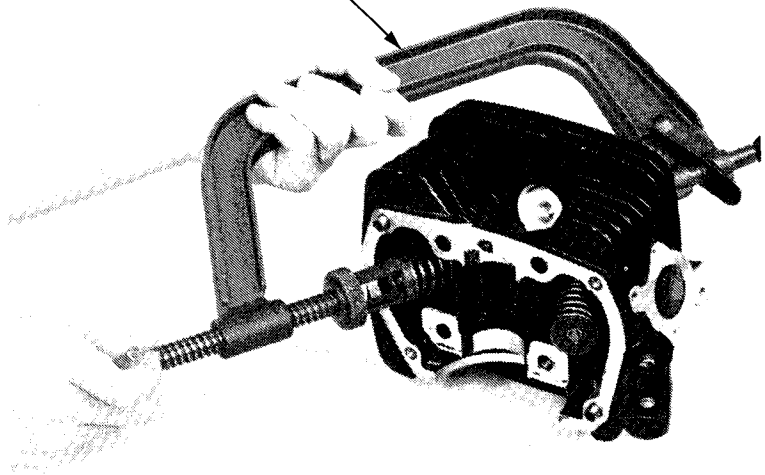

Tap the valve stems gently with a plastic hammer to firmly seat the cotters.

CAUTION:

Support the cylinder head above the work bench surface to prevent possible valve damage.

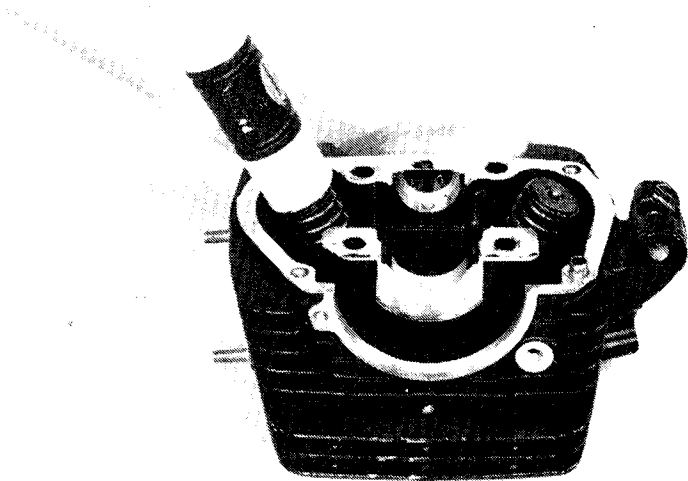

Clean off any gasket material from the cylinder surface.
Install the O-rings, dowel pins and a new gasket.

O-RING

DOWEL PINS

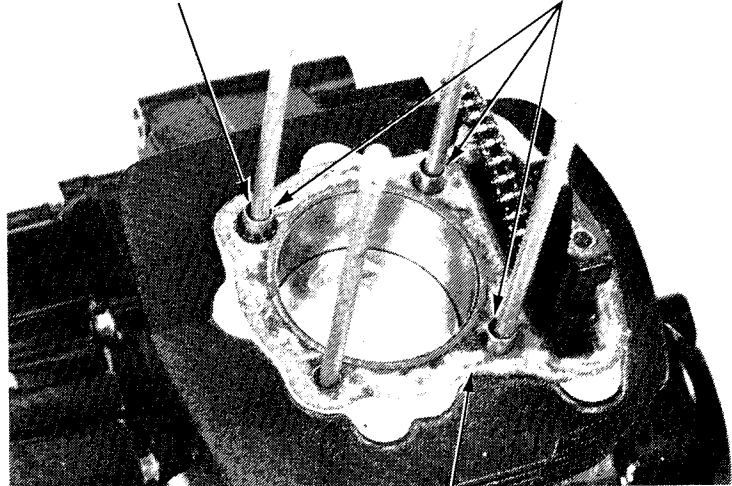

CYLINDER HEAD GASKET

Remove the rubber cap.
Remove the 6 mm bolt and loosen the tensioner adjusting bolt.
Push the tensioner set bar down with a screw driver, as shown, and tighten the adjusting bolt.

Install the 6 mm bolt and rubber cap.

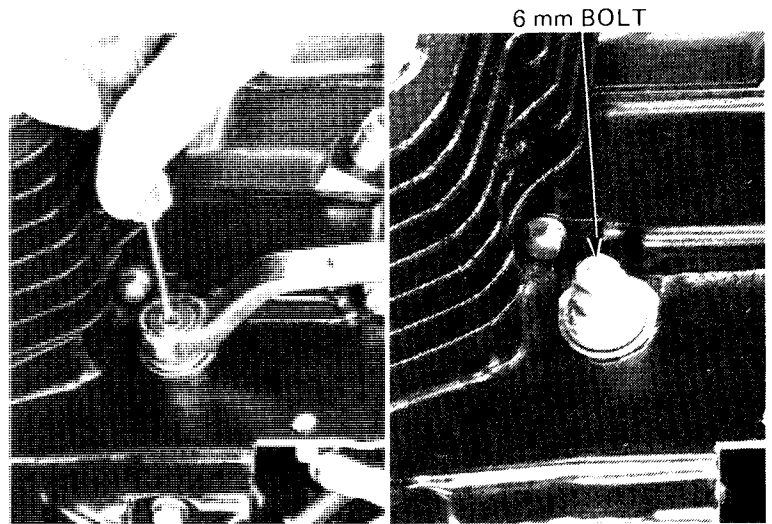

Install the cylinder head.
Install and tighten the tensioner bolt.

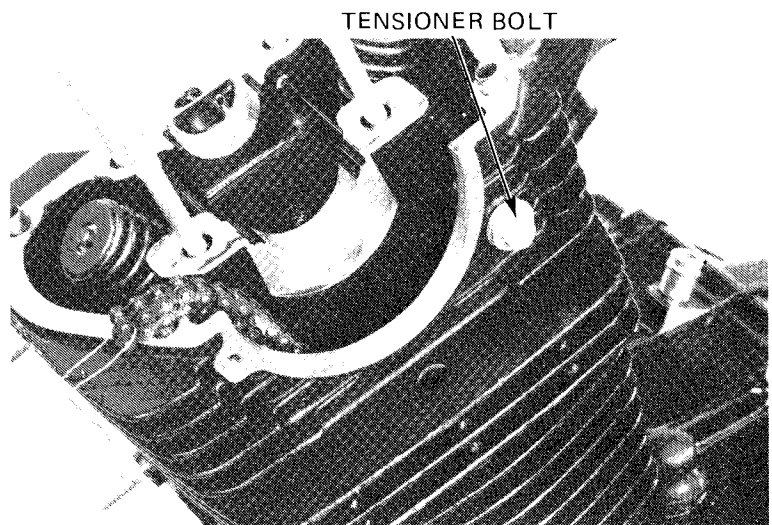

Install the dowel pins and camshaft bushing.

NOTE:

Align the camshaft bushing dowel pin with the cut-out in the cylinder head.

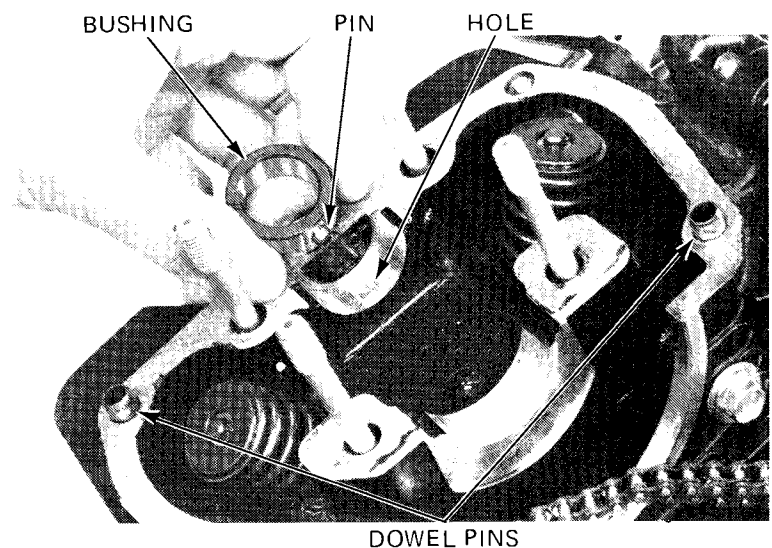

CYLINDER HEAD/VALVES

Install the oil hole plug.

Apply a thin, even coat of liquid sealant to the cylinder head cover mating surface.

NOTE:

Keep sealant away from the camshaft bearing surfaces.

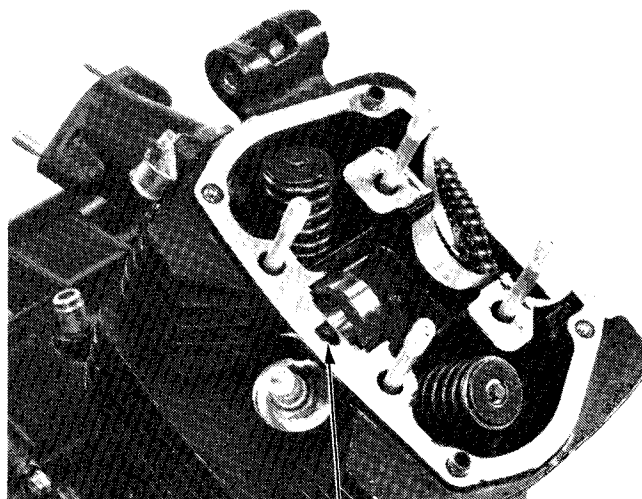

OIL HOLE PLUG

Install the rocker arms and rocker arm shafts in the cylinder head cover.

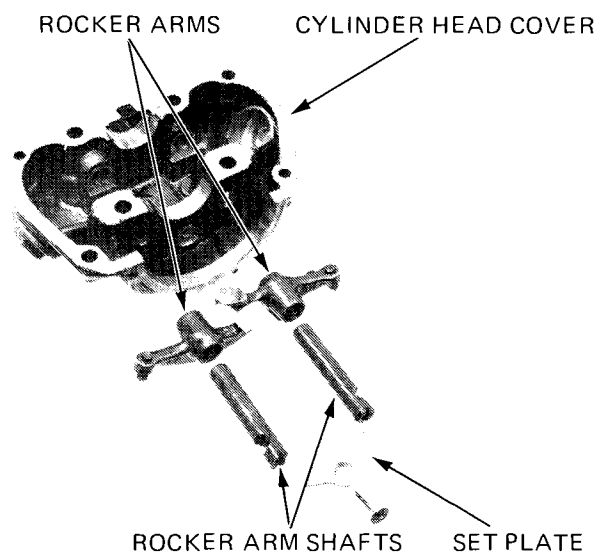

Install the set plate and tighten the set plate screw.

NOTE:

Clean the threads of the set plate screw and use a thread locking compound during assembly.

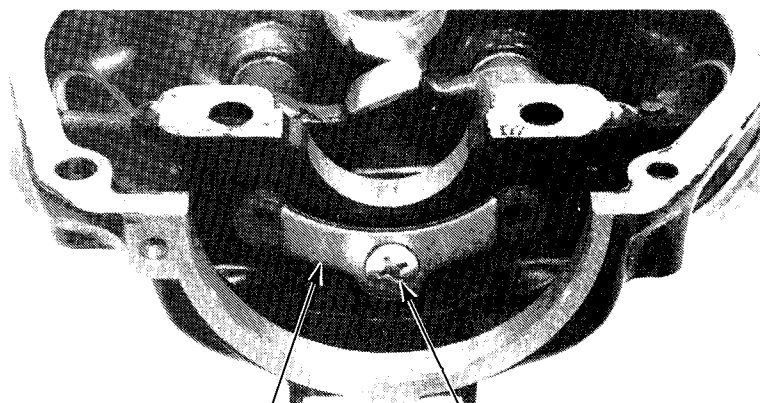

SET PLATE

SCREW

Coat the camshaft bearing and bushing with molybdenum disulfide grease.

Install the cylinder head cover.

Install the 8 mm cap nuts, 6 mm bolt and socket bolts.

Tighten the nuts and bolts in 2–3 steps in the pattern shown.

TORQUE:

8 mm nuts: 28–30 N·m
(2.8–3.0 kg·m, 20–22 ft·lb)

6 mm bolts: 8–12 N·m
(0.8–1.2 kg·m, 6–9 ft·lb)

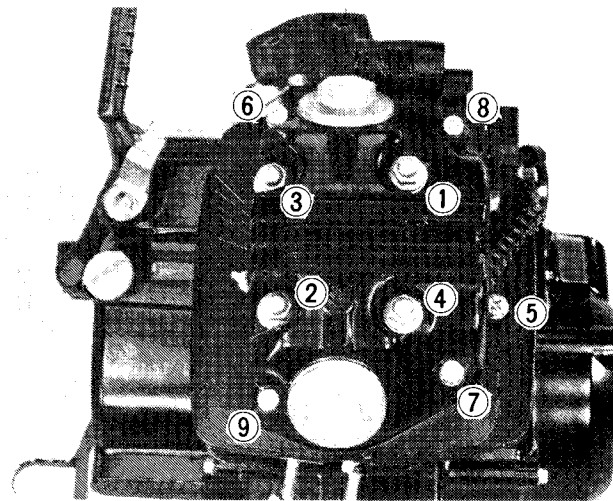

Pour fresh oil into the oil pockets in the cylinder head so that the cam lobes are submerged.

Coat the camshaft journals with molybdenum disulfide grease.

Install the thrust washer on the camshaft.

Route the camshaft through the cam chain and install the camshaft.

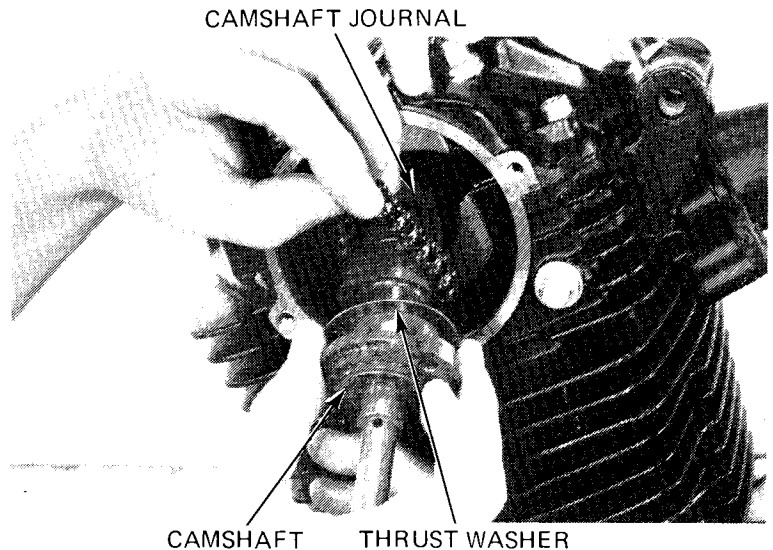

Turn the crankshaft counterclockwise and align the "T" mark with the index mark.

Install the cam sprocket.

Align the timing mark "o" on the cam sprocket with the index mark on the cylinder head cover.

Tighten the cam sprocket bolts.

TORQUE: 8–12 N·m (0.8–1.2 kg·m, 6–9 ft·lb)

Loosen the cam chain tensioner adjusting bolt and slowly turn the crankshaft counterclockwise one complete revolution. Tighten the adjusting bolt.

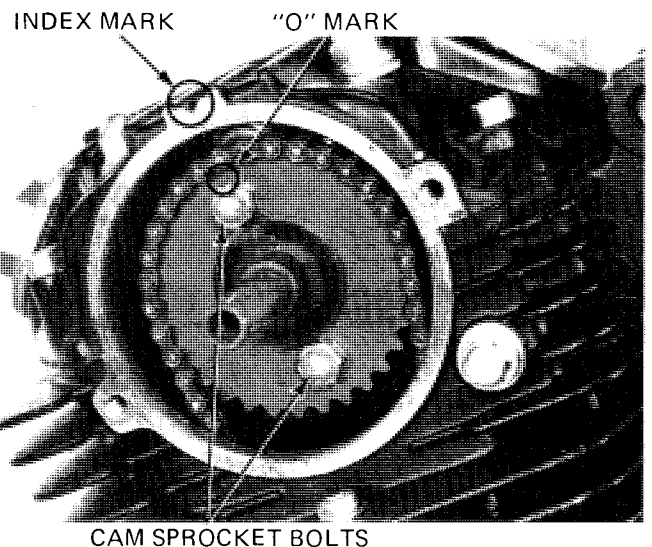

CYLINDER HEAD/VALVES

Install the pulse generator base.

NOTE:

Do not turn the oil seal lip inside out.

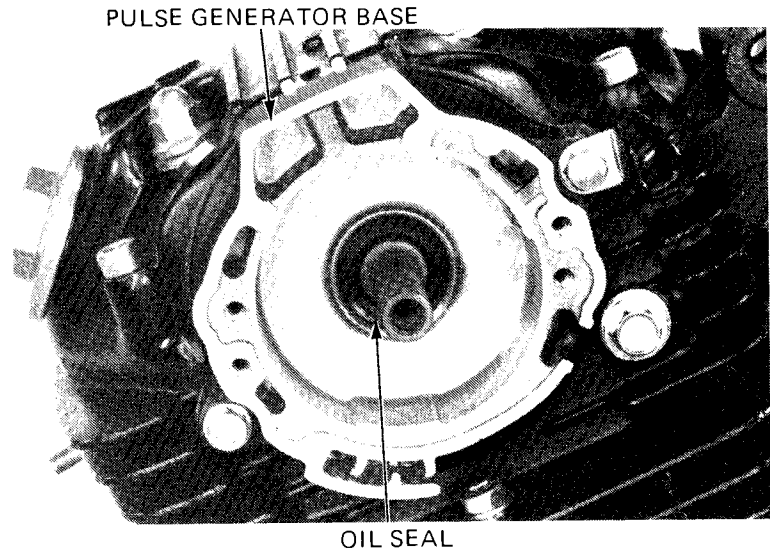

PULSE ROTOR ASSEMBLY

NOTE:

To assemble the pulse rotor, align the punch mark on the rotor with the index mark on the spark advancer.

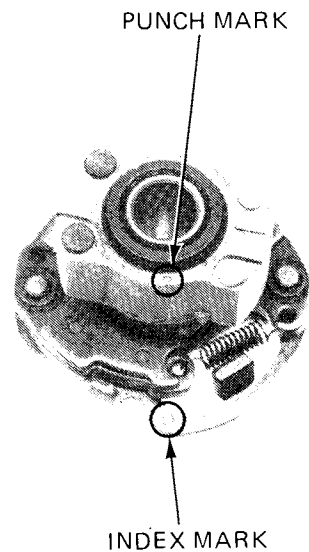

Install the dowel pin.
Install the pulse rotor.

NOTE:

Align the camshaft pin with the advancer groove.

Tighten the pulse rotor bolt.

TORQUE: 8–12 N·m (0.8–1.2 kg·m, 6–9 ft·lb)

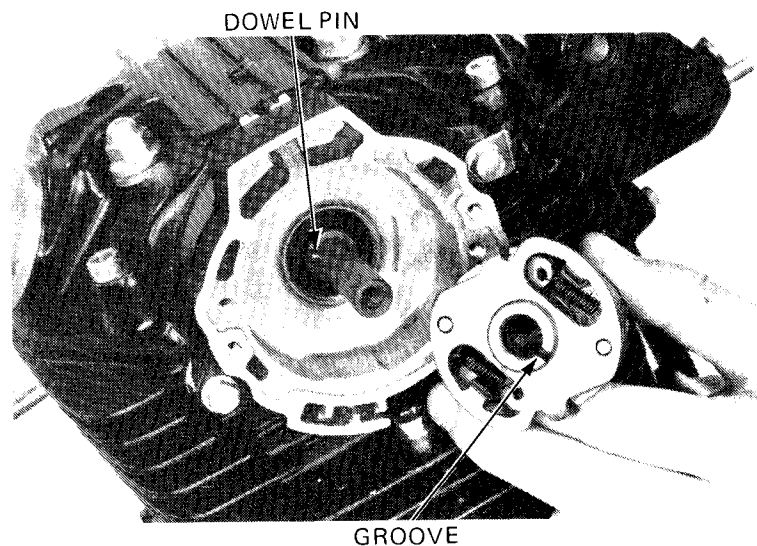

Install the pulse generator base plate.
Turn the crankshaft counterclockwise and align the "F" mark with the index mark.

Align the index mark on the pulse generator with the timing mark on the pulse rotor by rotating the base plate.
Tighten the screws.

Install the pulse generator cover.

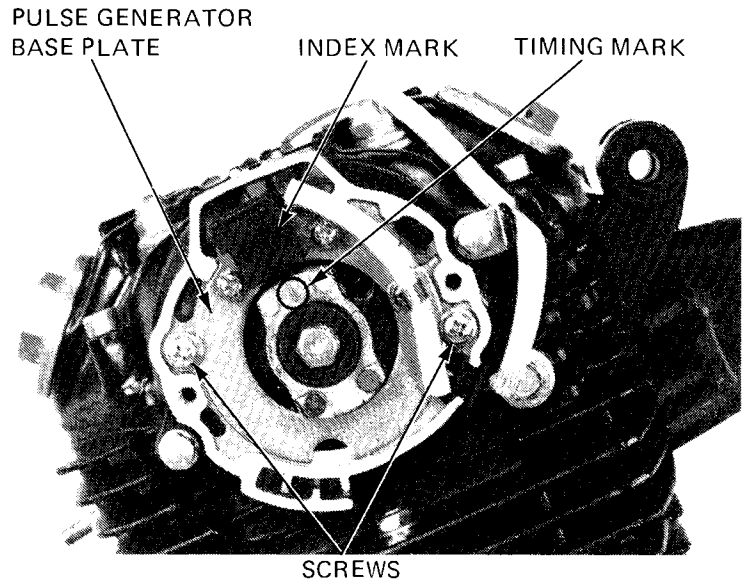

Adjust the valve clearance (page 3-5).
Adjust the cam chain tension (page 3-7).
Inspect and adjust the ignition timing (page 16-6).
Test the cylinder compression (page 3-8).

CYLINDER/PISTON

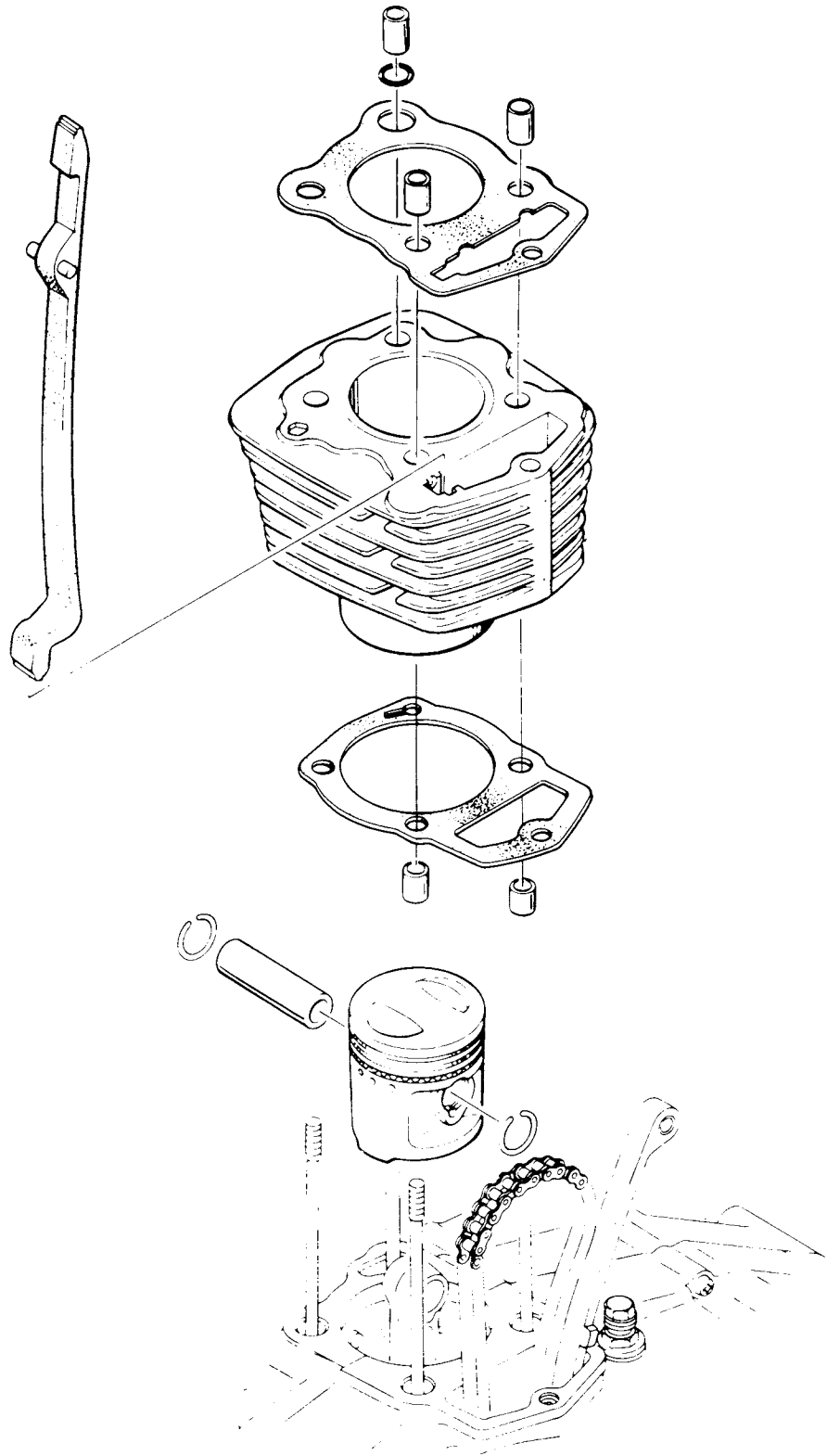

7. CYLINDER/PISTON

SERVICE INFORMATION	7-1
TROUBLESHOOTING	7-1
CYLINDER REMOVAL	7-2
PISTON REMOVAL	7-4
PISTON INSTALLATION	7-7
CYLINDER INSTALLATION	7-7

SERVICE INFORMATION

GENERAL

- Camshaft lubrication oil is fed to the cylinder head through an orifice in the cylinder and crankcase. Be sure this orifice is not clogged and that the O-rings and dowel pins are in place before installing the cylinder head.

SPECIFICATIONS

ITEM		STANDARD	SERVICE LIMIT	
Cylinder	I.D.	64.990–65.000 mm (2.5587–2.5591 in)	65.10 mm (2.563 in)	
	Taper	---	0.10 mm (0.004 in)	
	Out of round	---	0.10 mm (0.004 in)	
	Warpage across top	---	0.10 mm (0.004 in)	
Piston, piston pin, piston rings	Piston O.D.	64.962–64.982 mm (2.5576–2.5583 in)	64.90 mm (2.555 in)	
	Piston pin bore	15.002–15.008 mm (0.5906–0.5909 in)	15.04 mm (0.592 in)	
	Piston pin O.D.	14.995–15.000 mm (0.5903–0.5906 in)	14.96 mm (0.589 in)	
	Connecting rod small end I.D.	15.010–15.028 mm (0.5909–0.5917 in)	15.06 mm (0.593 in)	
	piston-to-pin clearance	0.002–0.014 mm (0.0001–0.0006 in)	0.02 mm (0.001 in)	
	Piston pin-to-connecting rod small end clearance	0.010–0.034 mm (0.0004–0.0013 in)	0.10 mm (0.004 in)	
	Piston-ring-to-ring groove clearance	TOP	0.010–0.045 mm (0.0004–0.0018 in)	0.09 mm (0.004 in)
		SEC.	0.015–0.045 mm (0.0006–0.0018 in)	0.09 mm (0.004 in)
	Piston ring end gap	TOP/SEC.	0.20–0.40 mm (0.008–0.016 in)	0.5 mm (0.02 in)
OIL		0.30–0.90 mm (0.012–0.035 in)	---	
Cylinder-to-piston clearance		0.018–0.048 mm (0.0007–0.0019 in)	0.10 mm (0.004 in)	

TROUBLESHOOTING

Low or unstable compression

1. Worn cylinder or piston rings.

Excessive smoke

1. Worn cylinder, piston, or piston rings.
2. Improper installation of piston rings.
3. Scored or scratched piston or cylinder wall.

Overheating

1. Excessive carbon build-up on piston or combustion chamber wall.

Knocking or abnormal noise

1. Worn piston and cylinder.
2. Excessive carbon build-up.

CYLINDER REMOVAL

Remove the engine from the frame (section 5).
Remove the pulse generator and camshaft (page 6-4).

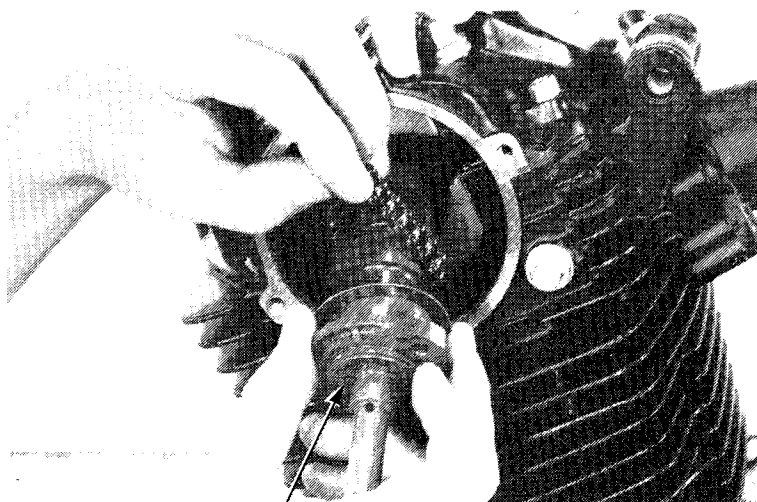

CAMSHAFT

Remove the 6 mm cylinder head bolt first and then remove the 8 mm cap nuts.

NOTE:

Loosen the cap nuts in a crisscross pattern in 2-3 steps.

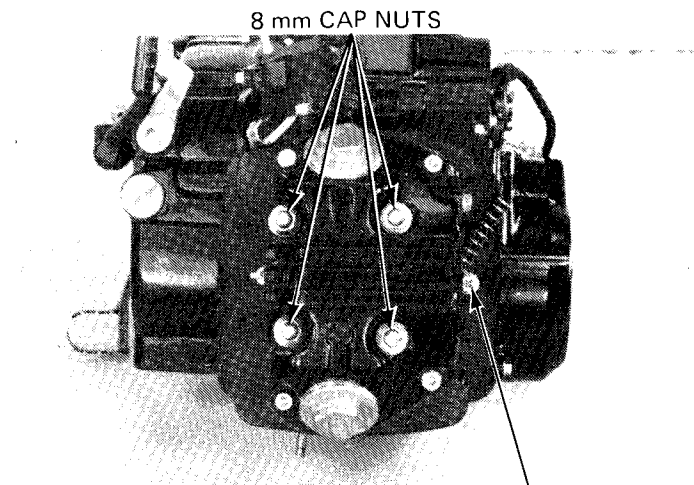

8 mm CAP NUTS

6 mm CYLINDER HEAD BOLT

Remove the cam chain tensioner bolts.
Remove the cylinder head assembly (page 6-6).

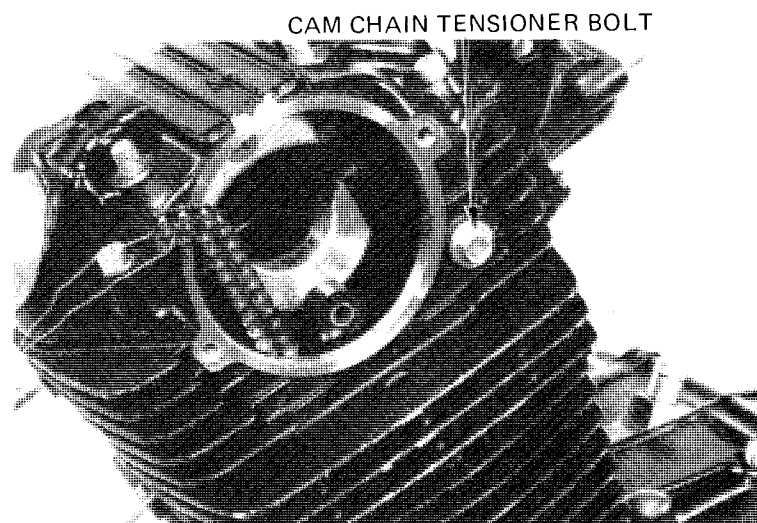

CAM CHAIN TENSIONER BOLT

Remove the gasket, dowel pins and O-ring.
Remove the cam chain guide.

NOTE:

Prevent the cam chain from falling into the crankcase when removing the cylinder.

Remove the cylinder.
Remove the cylinder gasket and dowel pins.

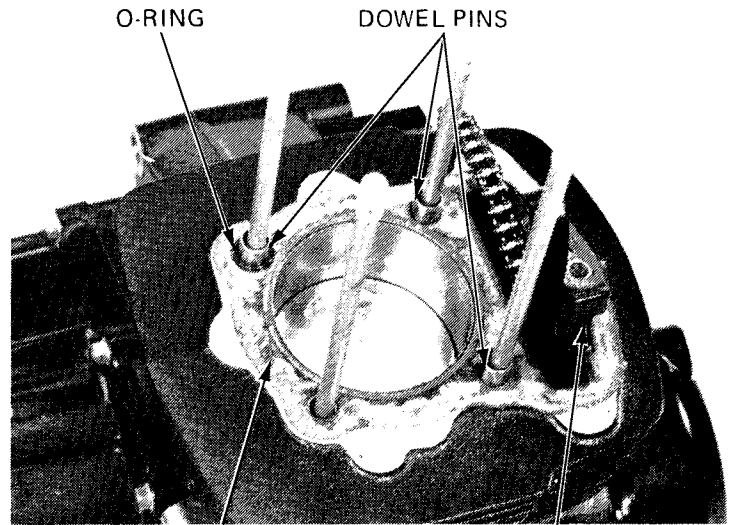

CYLINDER HEAD GASKET CAM CHAIN GUIDE

Clean off any gasket material from the cylinder surface.

NOTE:

Do not remove metal from the gasket surface.

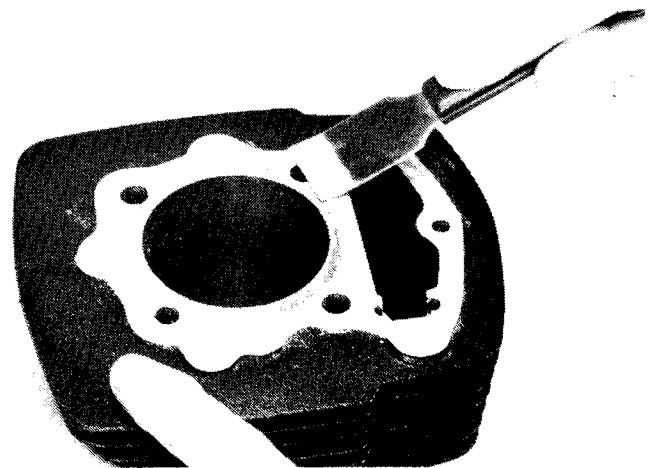

CYLINDER INSPECTION

Inspect the cylinder bore for wear or damage.
Measure the cylinder I.D.

SERVICE LIMIT: 65.10 mm (2.563 in)

NOTE:

Check for cylinder I.D. at X and Y axis at three locations.

Calculate the taper and out of round.

SERVICE LIMITS:

- Taper: 0.10 mm (0.004 in)
- Out of round: 0.10 mm (0.004 in)

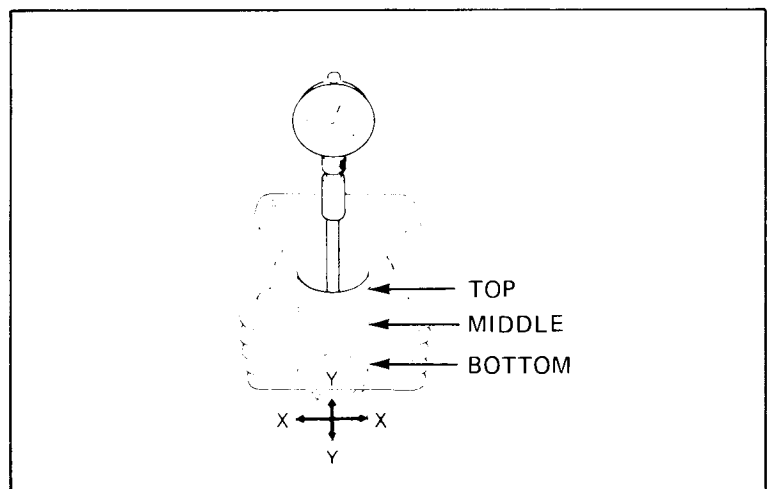

CYLINDER/PISTON

Inspect the top of the cylinder for warpage.

SERVICE LIMIT: 0.10 mm (0.004 in)

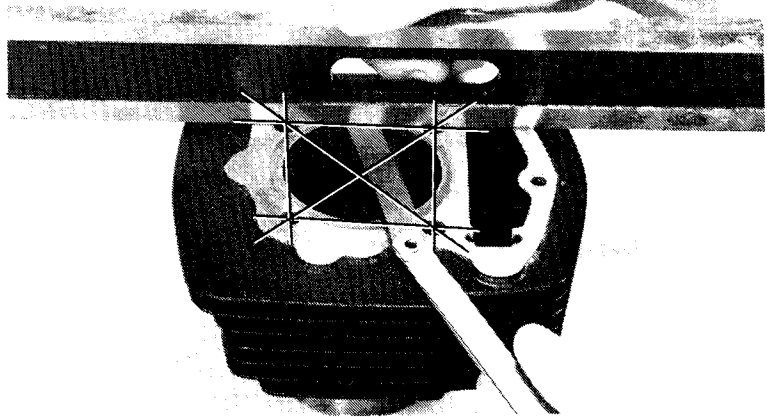

PISTON REMOVAL

NOTE:

Stuff a shop towel into the crankcase to prevent objects from falling in.

Remove the piston pin clip with pliers.
Press the piston pin out of the piston and remove the piston.

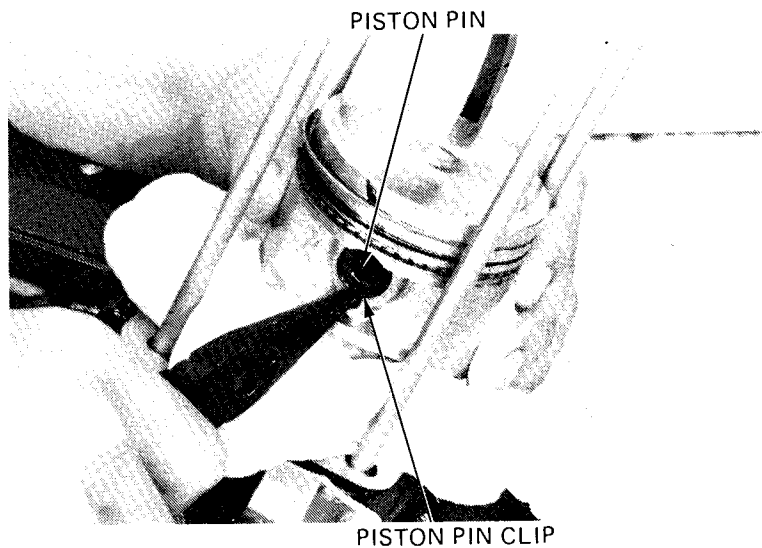

PISTON/PISTON RING INSPECTION

Measure the piston ring-to-groove clearance.

SERVICE LIMIT:

TOP/SECOND: 0.09 mm (0.0035 in)

Remove the piston rings.

NOTE:

Do not damage the piston rings during removal.

Inspect the piston for wear or damage.

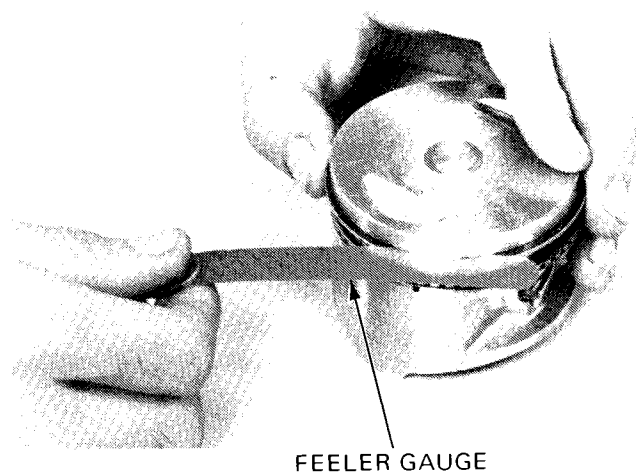

Insert each piston ring into the cylinder and measure the ring end gap.

SERVICE LIMITS:

TOP/SECOND: 0.5 mm (0.02 in)

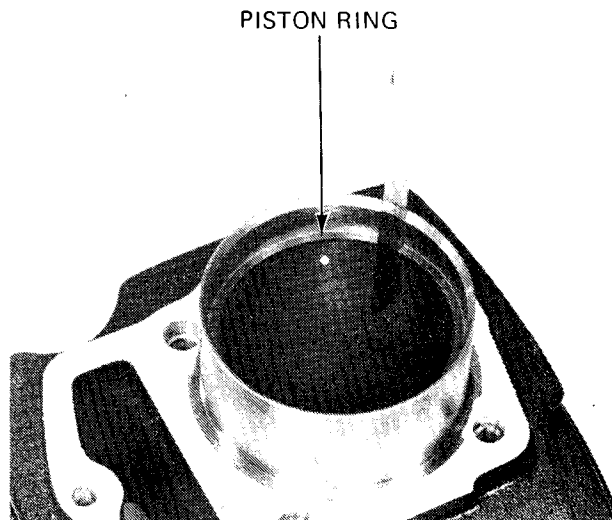

Measure the piston diameter 10 mm (0.4 in) from the bottom of the skirt.

SERVICE LIMIT: 64.90 mm (2.555 in)

NOTE:

Measure the piston diameter perpendicular to the piston pin hole.

Calculate the piston-to-cylinder clearance.

SERVICE LIMIT: 0.10 mm (0.004 in)

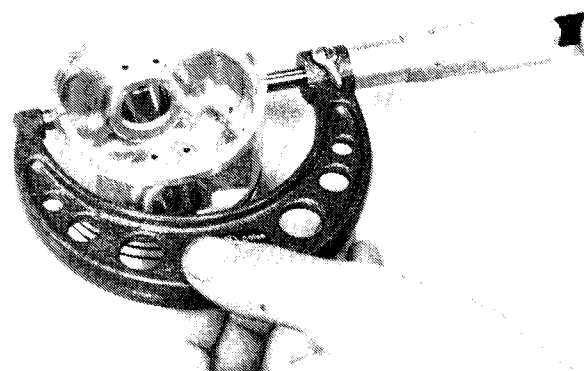

Measure the piston pin hole I.D.

SERVICE LIMIT: 15.04 mm (0.592 in)

Measure the connecting rod small end I.D.

SERVICE LIMIT: 15.06 mm (0.593 in)

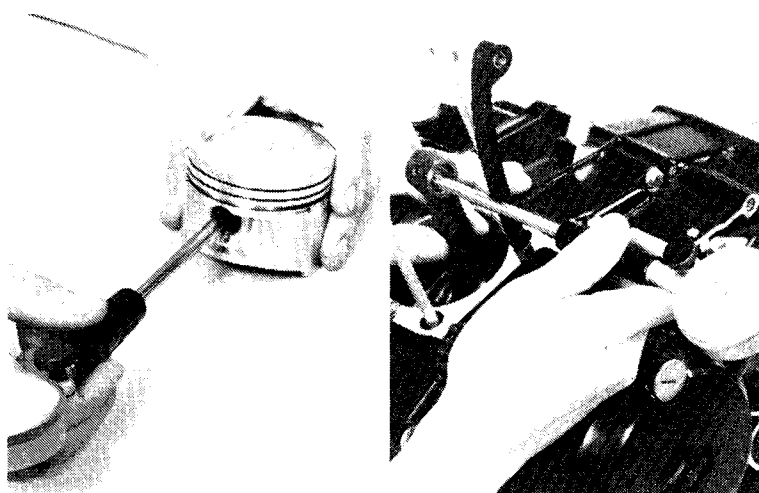

CYLINDER/PISTON

Measure the piston pin O.D.

SERVICE LIMIT: 14.96 mm (0.589 in)

Calculate the piston-to-piston pin clearance.

SERVICE LIMIT: 0.02 mm (0.001 in)

Calculate the piston pin-to-connecting rod small end clearance.

SERVICE LIMIT: 0.10 mm (0.004 in)

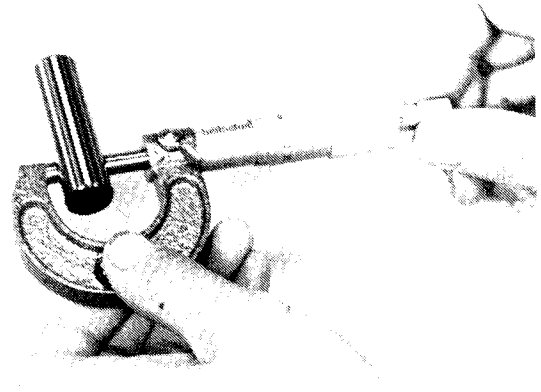

PISTON RING INSTALLATION

Clean the piston ring groove thoroughly.
Install the piston rings.

NOTE:

- Avoid piston and piston ring damage during installation.
- Install the piston rings with the marking facing up.
- Do not mix the top and second rings.

Space the piston ring end gaps 120 degrees apart.
Do not align the gaps of oil ring side rails.

After installation, the rings should be free to rotate in the ring grooves.

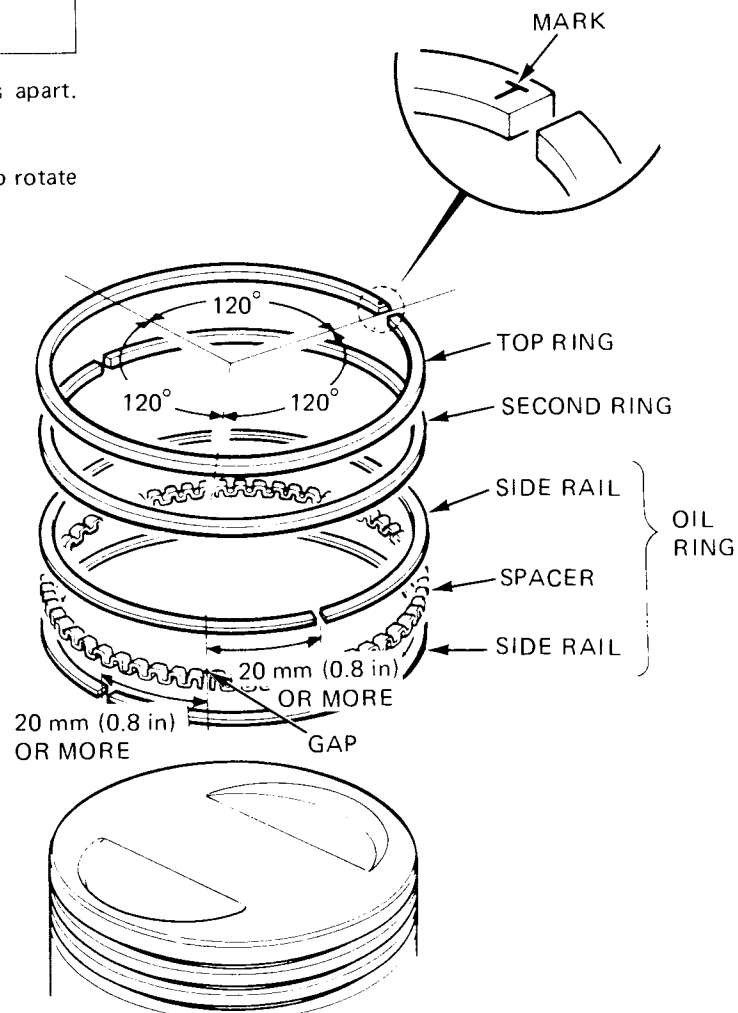

PISTON INSTALLATION

Install the piston and piston pin.
Install new piston pin clips.

NOTE:

- Position the piston "IN" mark on the intake valve side.
- Install the piston pin clips with the end gaps in the 12 o'clock position, towards the top of the piston.
- Do not let the clip fall into the crankcase.

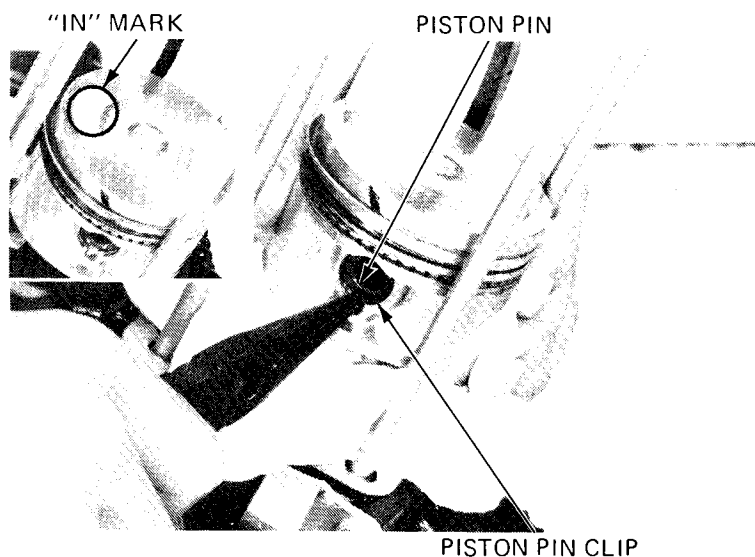

CYLINDER INSTALLATION

Install the cylinder gasket and dowel pins.

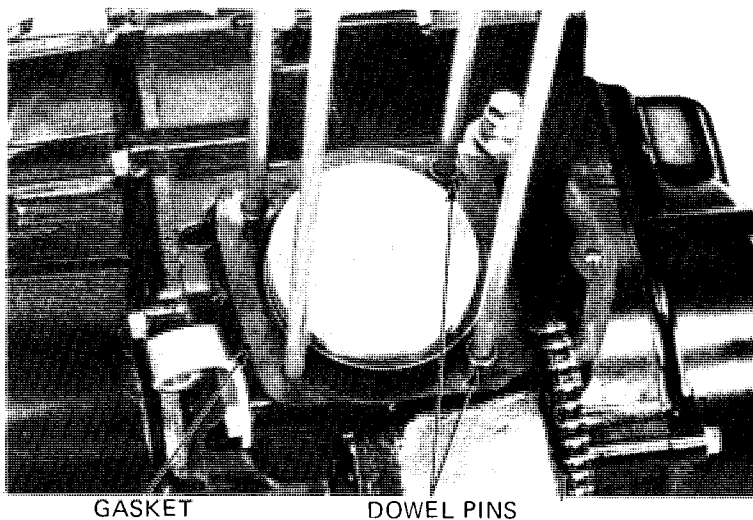

Coat the cylinder bore, piston and piston rings with engine oil and install the cylinder.

NOTE:

- Avoid piston ring damage during installation.
- Do not let the cam chain fall into the crankcase.

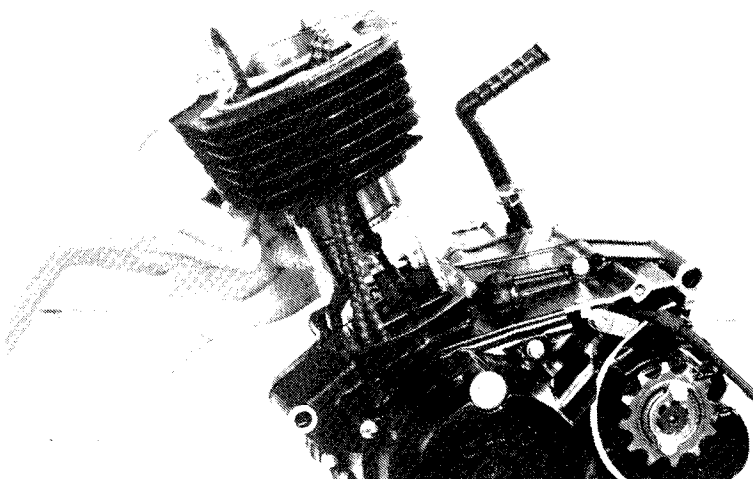

CYLINDER/PISTON

CYLINDER HEAD INSTALLATION

Install the cam chain guide.
Install the cylinder head gasket, dowel pins and O-ring.
Install the cylinder head.

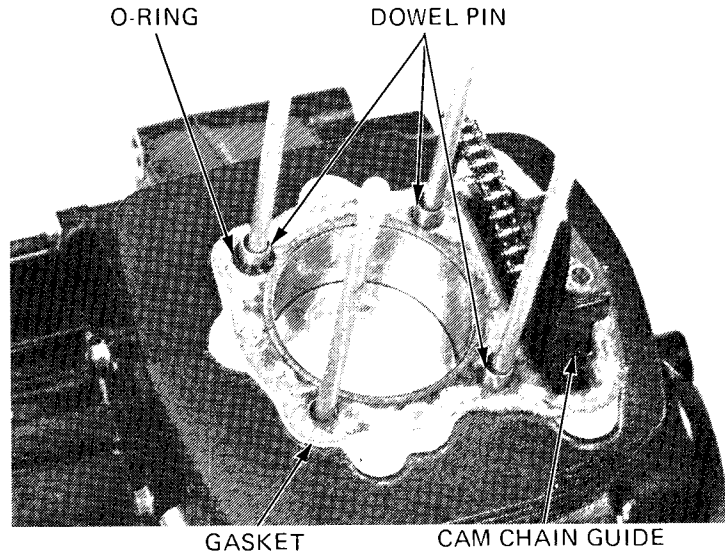

Install and tighten the cam chain tensioner bolt.

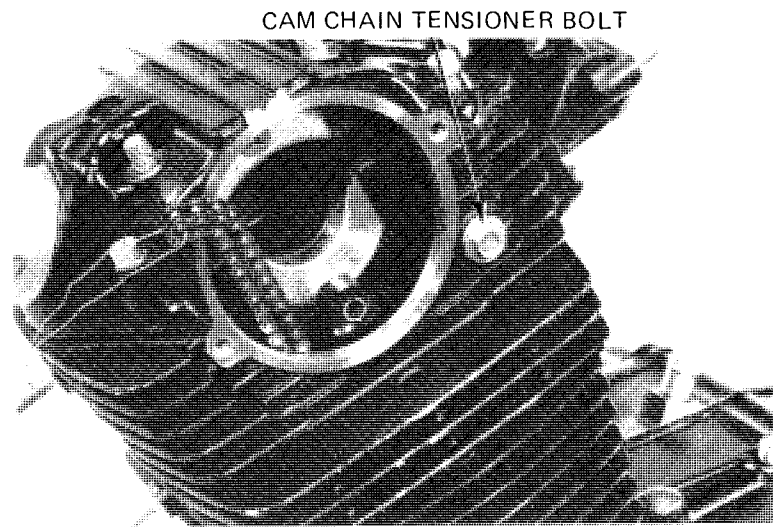

Install the 6 mm cylinder head bolt, 8 mm cap nuts and sealing washers.
Tighten the 8 mm cap nuts and 6 mm cylinder head bolt.

TORQUE VALUES:

8 mm: 28–30 N·m (2.8–3.0 kg·m, 20–22 ft·lb)
6 mm: 8–12 N·m (0.8–1.2 kg·m, 6–9 ft·lb)

NOTE:

Tighten the nuts and bolt in 2–3 steps in the pattern shown.

Install the camshaft (page 6-19).

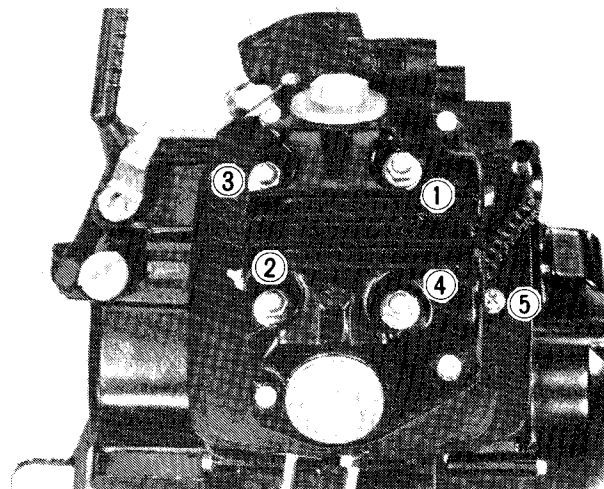

M E M O

CLUTCH/OIL PUMP/GEARSHIFT LINKAGE

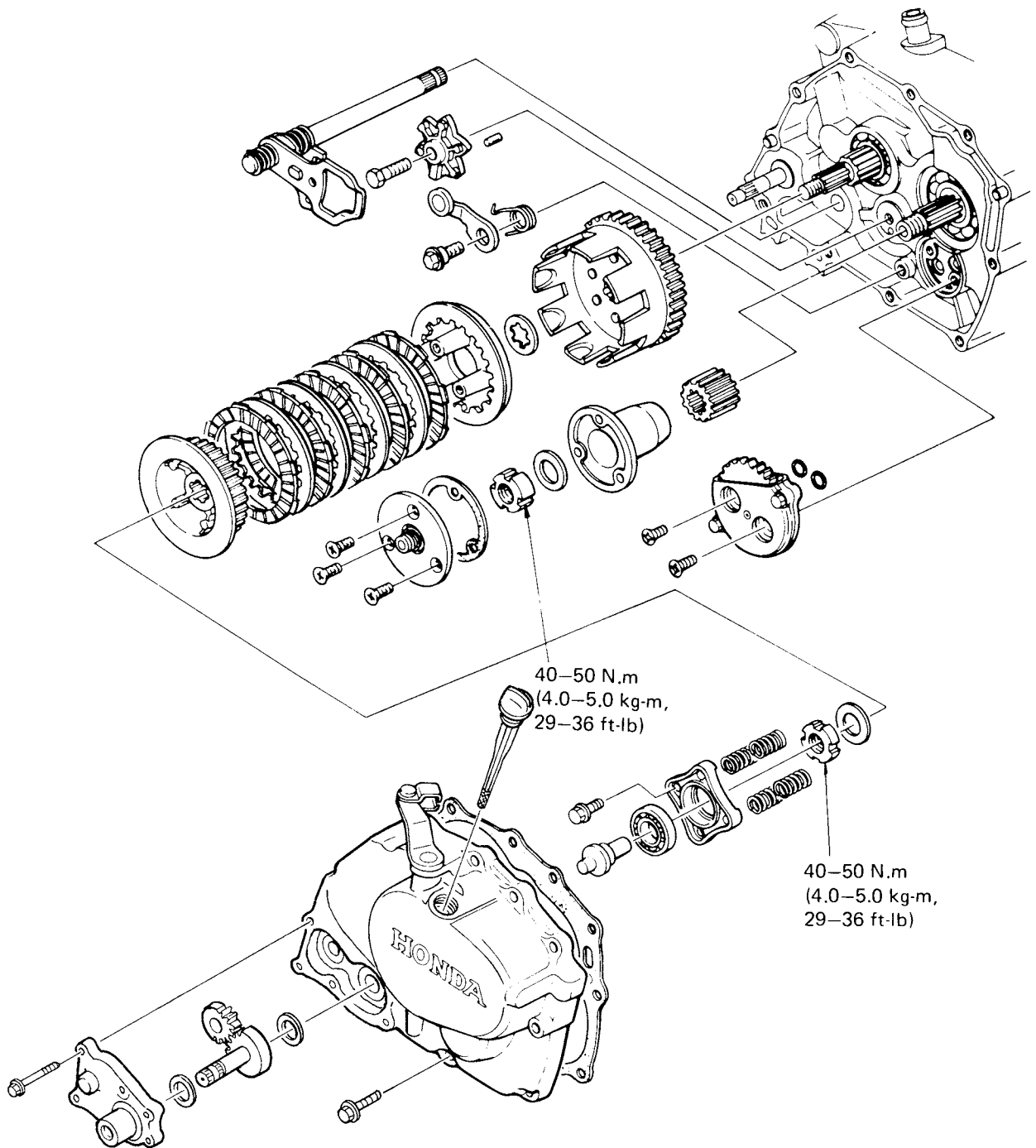

8. CLUTCH/OIL PUMP/GEARSHIFT LINKAGE

SERVICE INFORMATION	8-1
TROUBLESHOOTING	8-2
RIGHT CRANKCASE COVER REMOVAL	8-3
CLUTCH	8-4
OIL PUMP	8-10
GEARSHIFT LINKAGE	8-13
RIGHT CRANKCASE COVER INSTALLATION	8-14

SERVICE INFORMATION

GENERAL

- This section covers removal and installation of the clutch, oil pump, oil filter rotor and gearshift linkage. All these operations can be done with the engine installed.

SPECIFICATIONS

ITEMS		STANDARD	SERVICE LIMIT	
Clutch	Lever free play	10–20 mm (3/8–3/4 in)	—	
	Spring	Free length	37.9 mm (1.49 in)	34.7 mm (1.37 in)
		Preload	23.5–25.5 kg (51.8–56.2 lbs)	—
	Disc thickness	2.9–3.0 mm (0.11–0.12 in)	2.6 mm (0.10 in)	
	Plate warpage	—	0.20 mm (0.008 in)	
	Disc warpage	—	0.20 mm (0.008 in)	
Oil pump	Tip clearance	0.15 mm (0.006 in)	0.20 mm (0.008 in)	
	Body clearance	0.30–0.36 mm (0.012–0.014 in)	0.40 mm (0.016 in)	
	Pump end clearance	0.15–0.20 mm (0.006–0.008 in)	0.25 mm (0.010 in)	
	Output	4.0 lit. (4.2 US qt, 3.5 Imp qt) at 8,000 rpm/min.	—	

TORQUE VALUES

Oil filter rotor	40–50 N·m (4.0–5.0 kg·m, 29–36 ft·lb)
Clutch center	40–50 N·m (4.0–5.0 kg·m, 29–36 ft·lb)
Oil filter screen cap	10–20 N·m (1.0–2.0 kg·m, 7–14 ft·lb)

TOOLS

Special

Clutch holder 07923–1070001

Common

Universal holder 07725–0030000
 Lock nut wrench, 20 x 24 mm 07716–0020100
 Extension 07716–0020500 (Equivalent tool commercially available in U.S.A.)

TROUBLESHOOTING

Faulty clutch operation can usually be corrected by adjusting the clutch lever free play.

Clutch slips when accelerating

1. No free play.
2. Discs worn.
3. Springs weak.

Clutch will not disengage

1. Too much free play.
2. Plates warped.

ATC creeps with clutch disengaged

1. Too much free play.
2. Plates warped.

Excessive lever pressure

1. Clutch cable kinked, damaged or dirty.
2. Lifter mechanism damaged.

Clutch operation feels rough

1. Outer drum slots rough.
2. Clutch cable kinked, damaged or dirty.

Hard to shift

1. Stopper plate damaged.
2. Incorrect clutch adjustment.

Gearshift pedal will not return

1. Weak or broken shift return spring.
2. Shift spindle binding with case.

Transmission jumps out of gear

1. Weak or broken stopper spring.

Low oil pressure

1. Faulty oil pump.
2. Oil pump drive gear broken.

RIGHT CRANKCASE COVER REMOVAL

Drain the oil from the crankcase.
 Remove the right footpeg bracket.
 Remove the cotter pin, washer and joint pin, and disconnect the brake rod from the brake arm.
 Remove the kick starter pedal and rear brake pedal.
 Disconnect the clutch cable from the clutch arm.

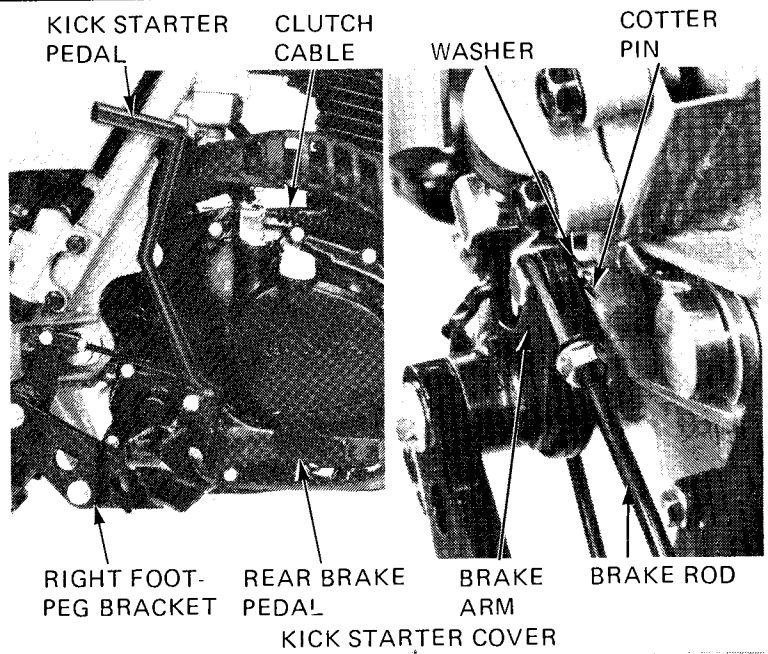

Remove the kick starter cover.

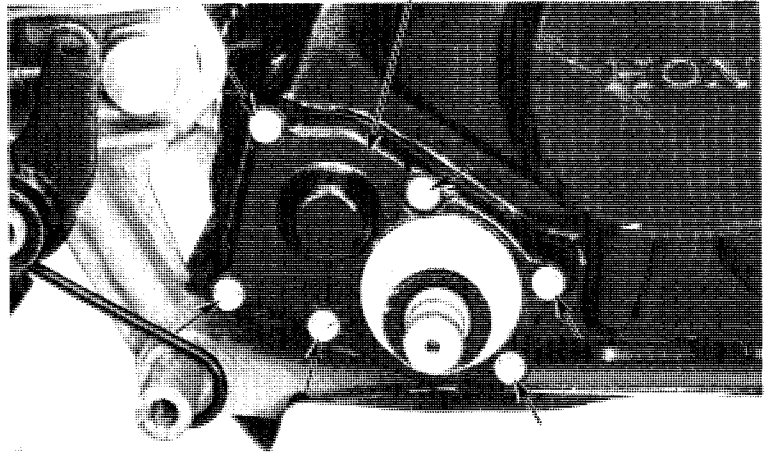

Remove the gasket.

Remove the kick starter drive gear, spindle and driven gear.

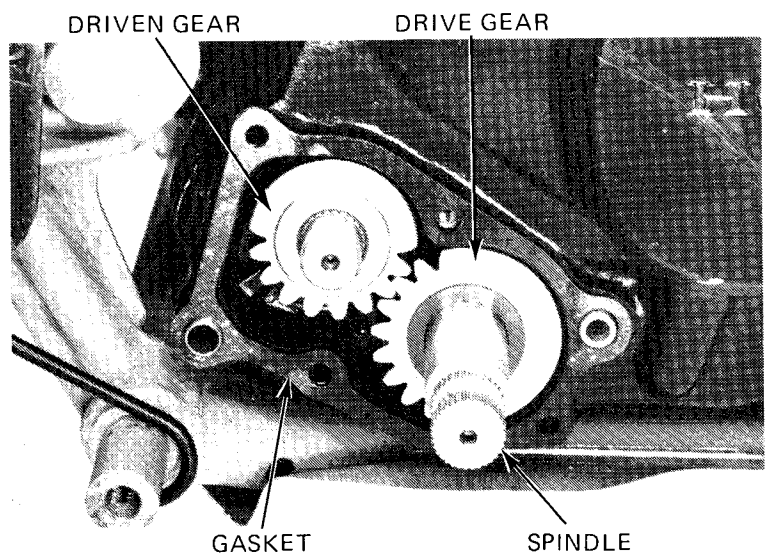

CLUTCH/OIL PUMP/GEARSHIFT LINKAGE

Remove the right crankcase cover.

RIGHT CRANKCASE COVER

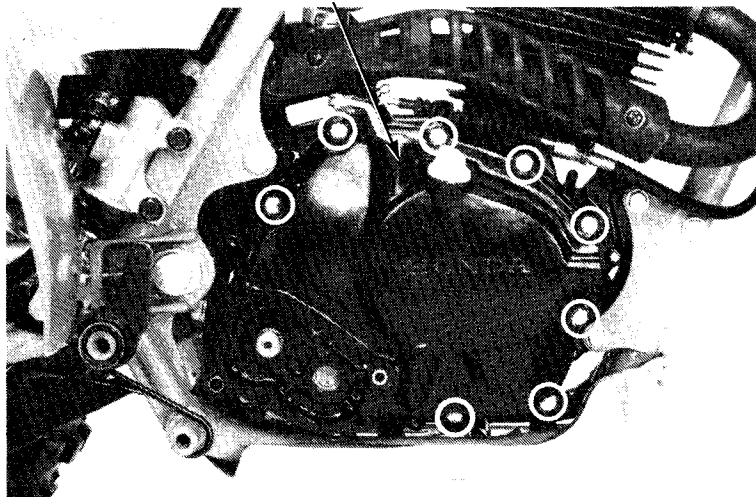

CLUTCH ARM REMOVAL

Remove the spring pin and clutch arm return spring. Remove the clutch arm and shaft from the right crankcase cover.

CLUTCH ARM INSTALLATION

Install the clutch arm and shaft into the right crankcase cover. Install the return spring and pin onto the shaft and hook the spring ends as shown.

RETURN SPRING

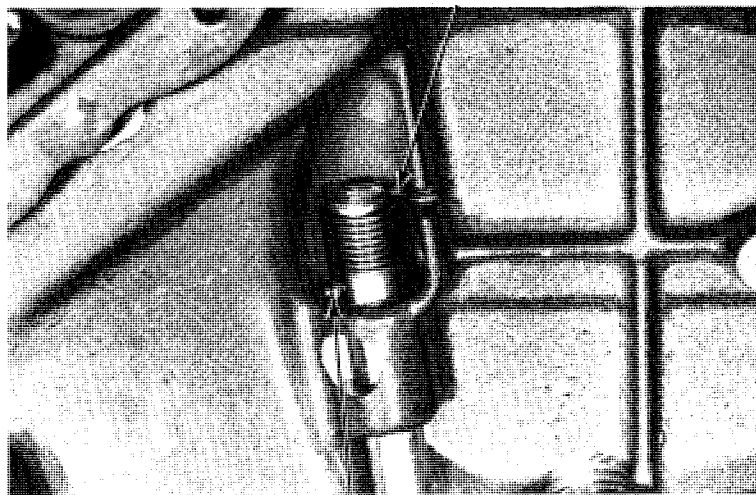

SPRING PIN

CLUTCH

REMOVAL

Remove the oil filter rotor cover.
Remove the clutch lifter rod.

CLUTCH LIFTER ROD

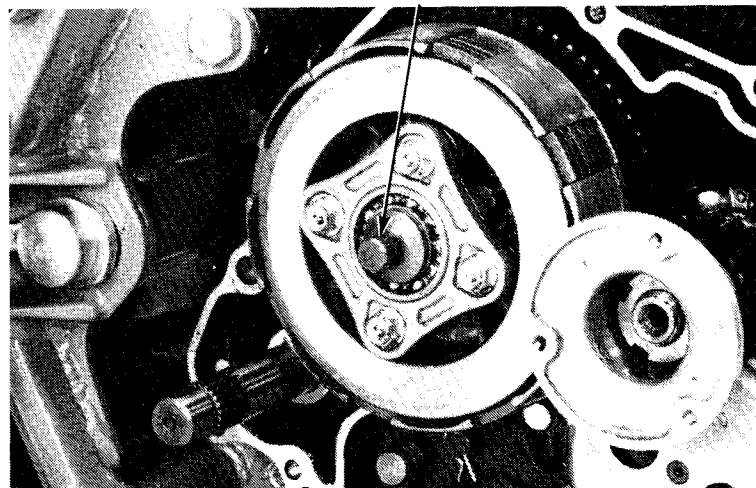

CLUTCH/OIL PUMP/GEARSHIFT LINKAGE

Remove the oil filter lock nut with a clutch outer holder, lock nut wrench socket and extension. Remove the lock washer and oil filter rotor.

LOCK NUT WRENCH, 20 x 24 mm
07716-0020100

EXTENSION 07716-0020500
or equivalent tool commercially
available in U.S.A.

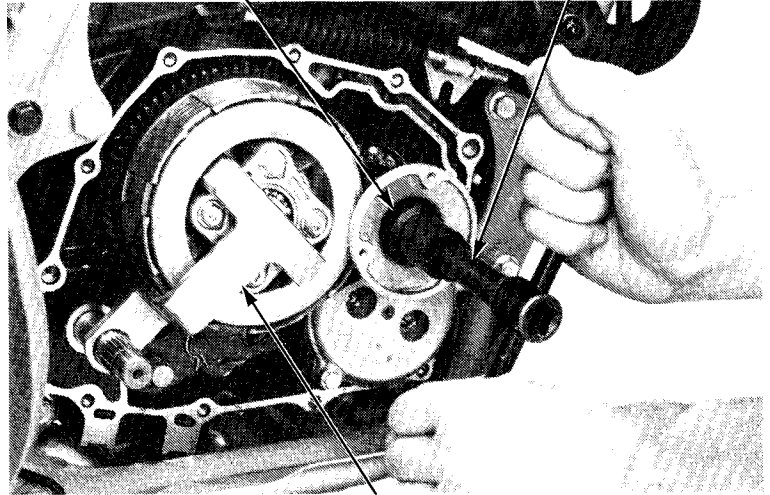

CLUTCH HOLDER 07923-1070001

Remove the clutch bolts, clutch lifter plate and clutch springs.

NOTE:

Loosen the bolts in a crisscross pattern in 2-3 steps.

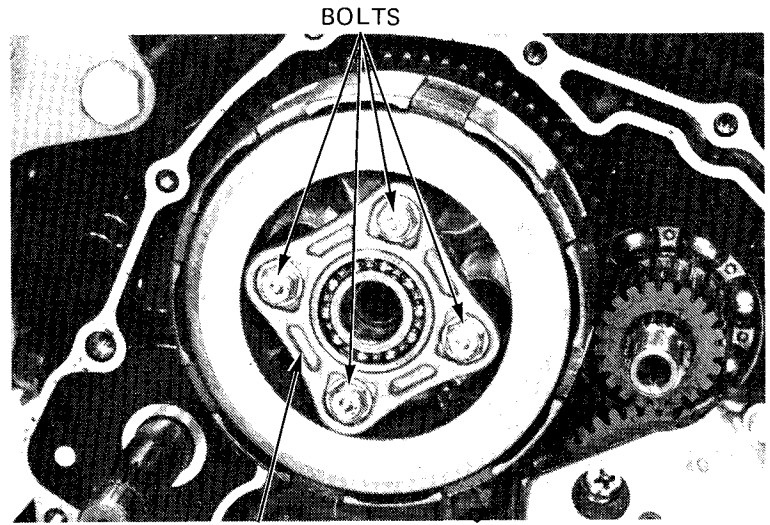

LIFTER PLATE

LOCK NUT WRENCH, 20 x 24 mm
07716-0020100

Remove the drive sprocket cover.
Remove the drive chain.
Shift the transmission into top gear.
Hold the drive sprocket with a universal holder to prevent it from turning.
Remove the clutch lock nut and the clutch center.
Remove the clutch discs and clutch plates.

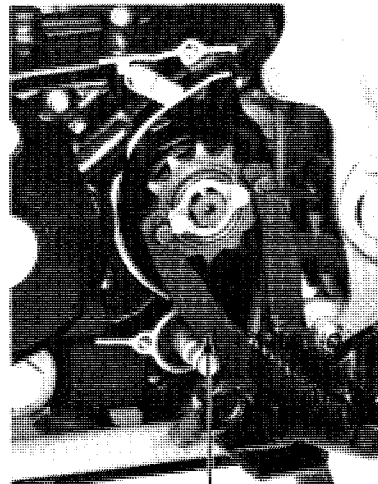

UNIVERSAL HOLDER
07725-0030000

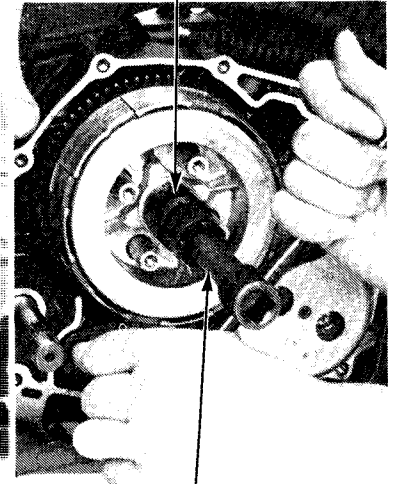

EXTENSION 07716-0020500 or
equivalent tool commercially
available in U.S.A.

CLUTCH/OIL PUMP/GEARSHIFT LINKAGE

Remove the spline washer and clutch outer.
Remove the primary drive gear.

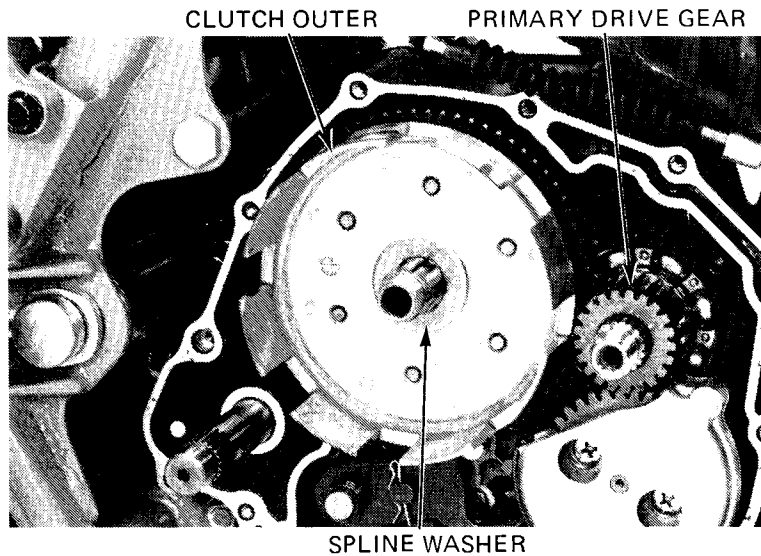

INSPECTION

Measure the spring free length.

SERVICE LIMIT: 34.7 mm (1.37 in)

NOTE:

Clutch springs should be replaced as a set even if one is shorter than the service limit.

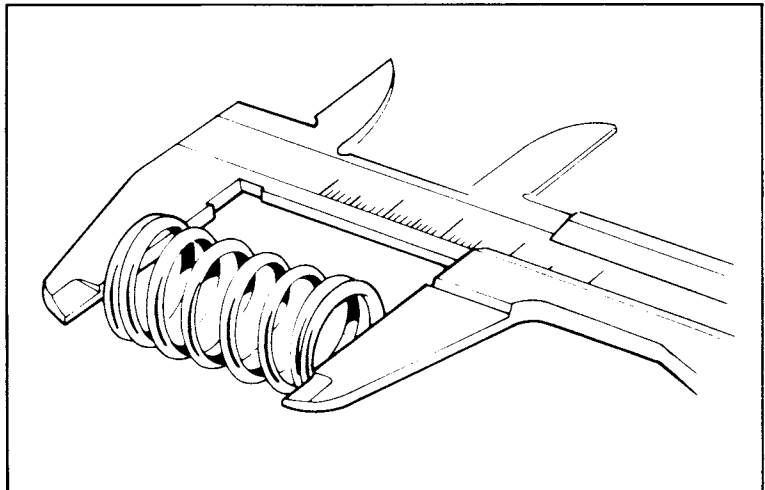

Replace the clutch discs if they show signs of scoring or discoloration.

Measure the disc thickness.

SERVICE LIMIT: 2.6 mm (0.10 in)

NOTE:

Clutch discs and plates should be replaced as a set if any one is beyond the service limit.

Check the slots in the clutch outer for nicks or indentations made by clutch discs.

Replace if necessary.

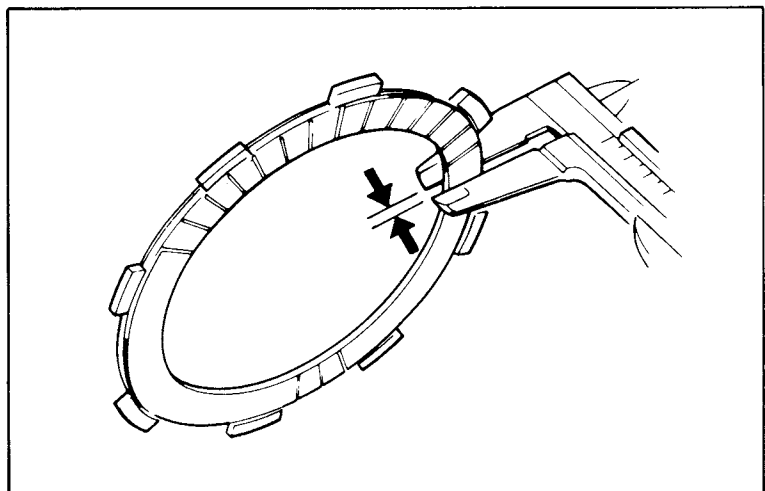

Check for plate warpage on a surface plate, using a feeler gauge.

SERVICE LIMIT: 0.20 mm (0.008 in)

Check the slots in the clutch center for nicks or indentations made by the clutch plates. Replace if necessary.

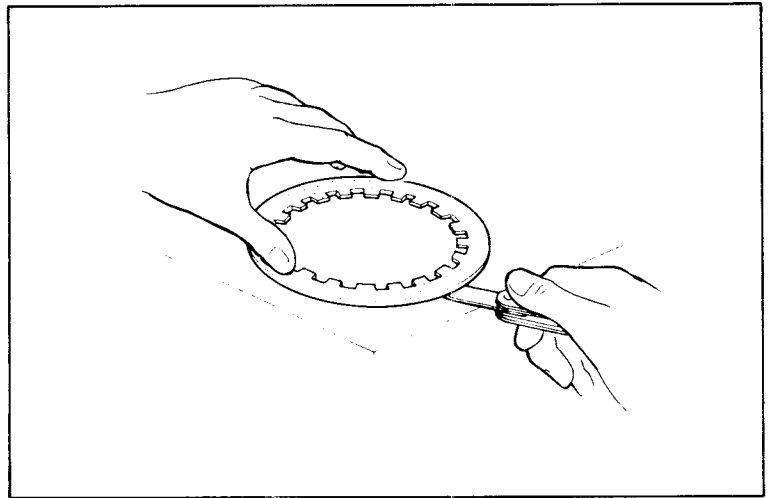

INSTALLATION

Install the primary drive gear.
Install the clutch outer.
Install the spline washer.
Assemble the pressure plate, discs, clutch plates and clutch center.

NOTE:

- Stack the discs and plates alternately.
- Coat new clutch discs with engine oil.

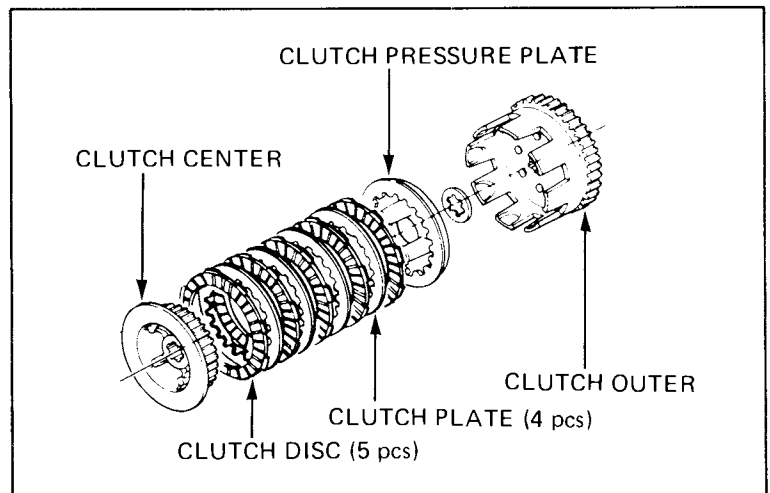

Install the lock washer and lock nut.

NOTE:

- Install the lock washer with the word "OUT SIDE" facing out.

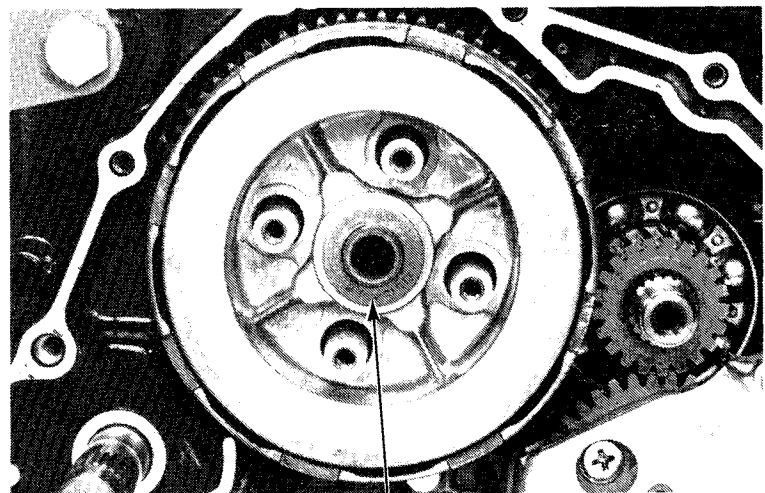

LOCK WASHER

CLUTCH/OIL PUMP/GEARSHIFT LINKAGE

Shift the transmission into top gear.
Use a universal holder to prevent the drive sprocket from turning.

Tighten the lock nut to the specified torque.
TORQUE: 40–50 N·m (4.0–5.0 kg·m, 29–36 ft·lb)

Install the drive chain and drive sprocket cover.

LOCK NUT WRENCH, 20 x 24 mm
07716-0020100

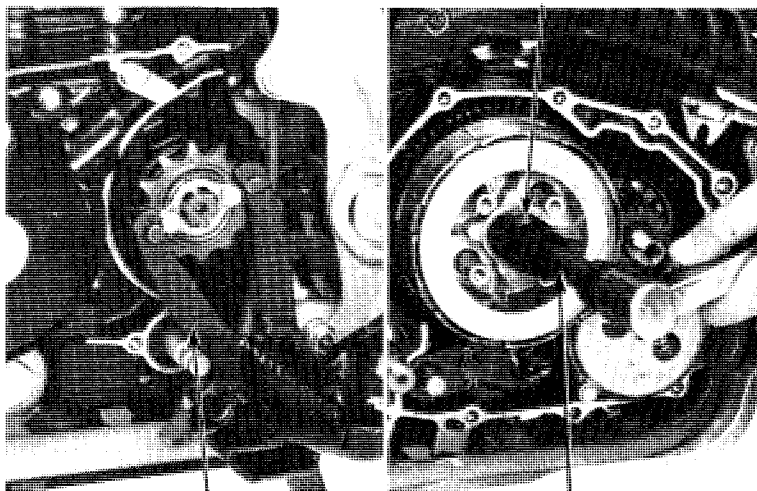

UNIVERSAL HOLDER
07725-0030000

EXTENSION 07716-0020500
or equivalent tool commercially
available in U.S.A.

Install the clutch springs and lifter plate, and tighten the bolts in a crisscross pattern in 2–3 steps.

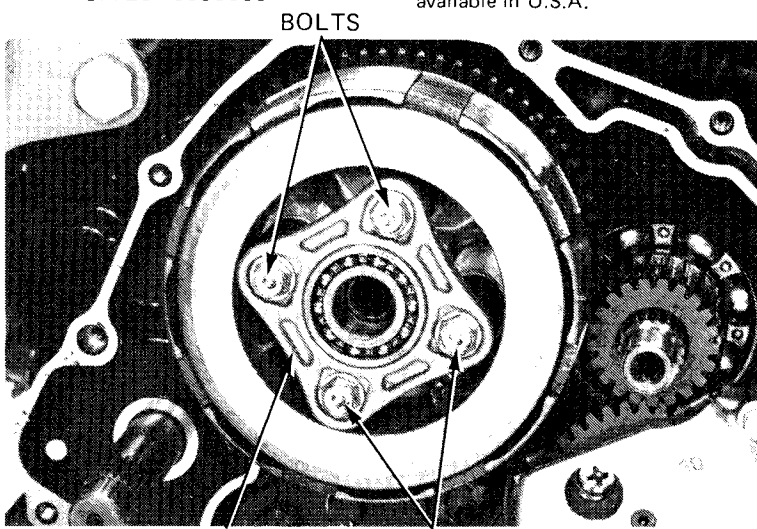

LIFTER PLATE BOLTS

Clean the oil filter rotor and install it.
Install the lock washer with the word "OUT SIDE" facing out.

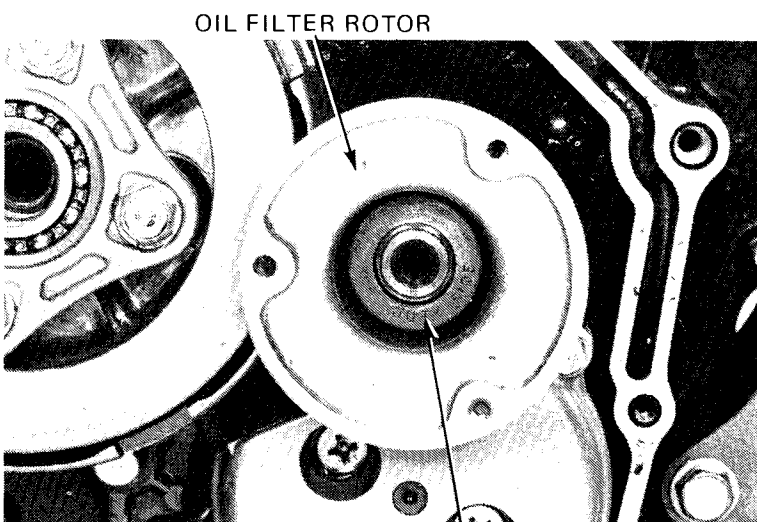

OIL FILTER ROTOR

LOCK WASHER

CLUTCH/OIL PUMP/GEARSHIFT LINKAGE

Tighten the lock nut to the specified torque.

TORQUE: 40–50 N·m (4.0–5.0 kg·m, 29–36 ft·lb)

LOCK NUT WRENCH, 20 x 24 mm
07716-0020100

EXTENSION 07716-0020500
or equivalent tool commercially
available in U.S.A.

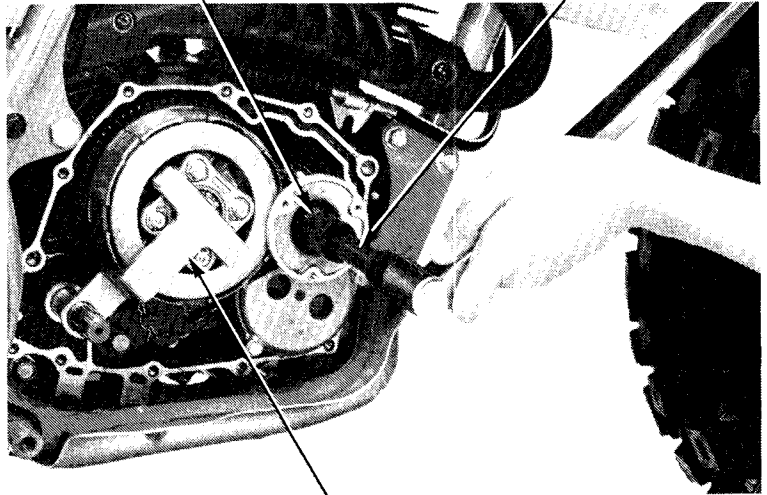

CLUTCH HOLDER
07923-1070001

Install the clutch lifter rod.

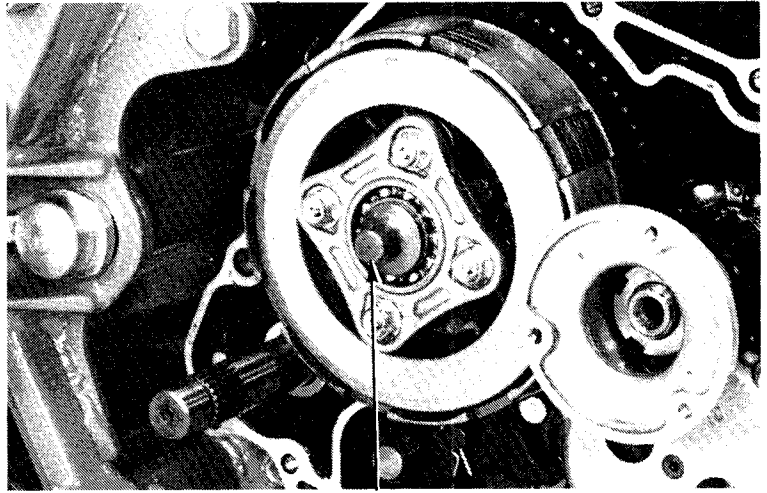

CLUTCH LIFTER ROD

Install the oil filter rotor cover.
Check that the oil passage pipe operates freely,
without binding.

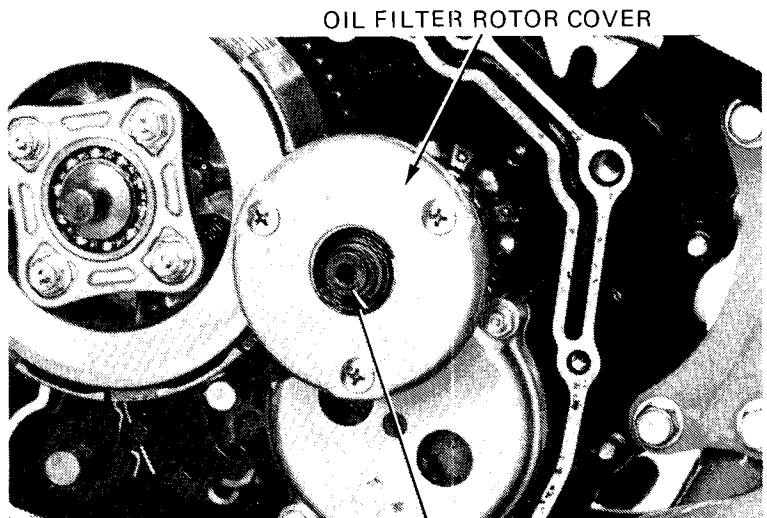

OIL FILTER ROTOR COVER

OIL PASSAGE PIPE

OIL PUMP

REMOVAL

Remove the oil filter rotor (page 8-4).
Remove the oil pump mounting screws, and remove the oil pump.

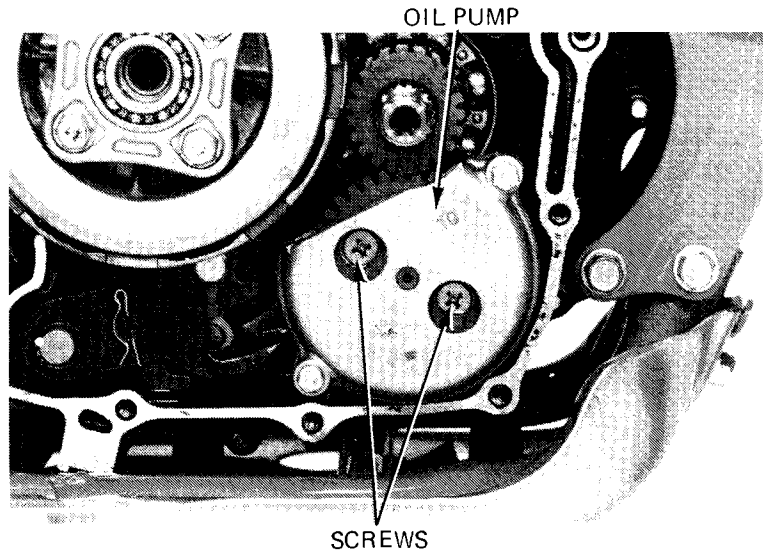

DISASSEMBLY

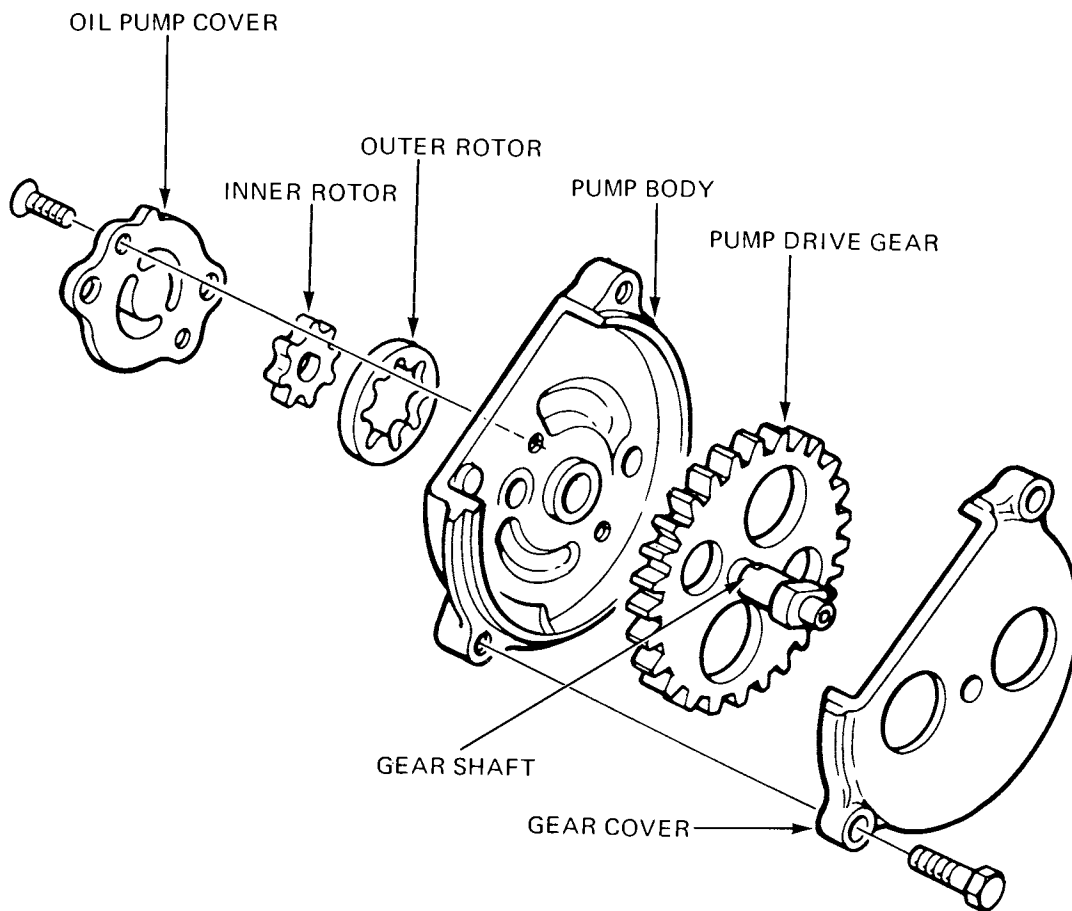

INSPECTION

Measure the pump body clearance.

SERVICE LIMIT: 0.40 mm (0.016 in)

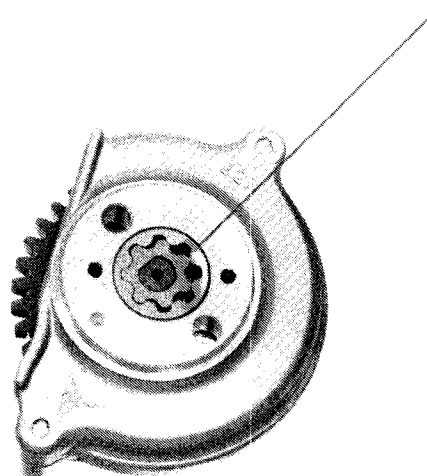

Measure the pump tip clearance.

SERVICE LIMIT: 0.20 mm (0.008 in)

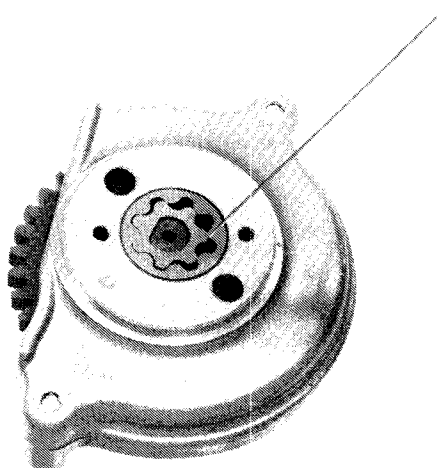

Measure the pump end clearance.

SERVICE LIMIT: 0.25 mm (0.010 in)

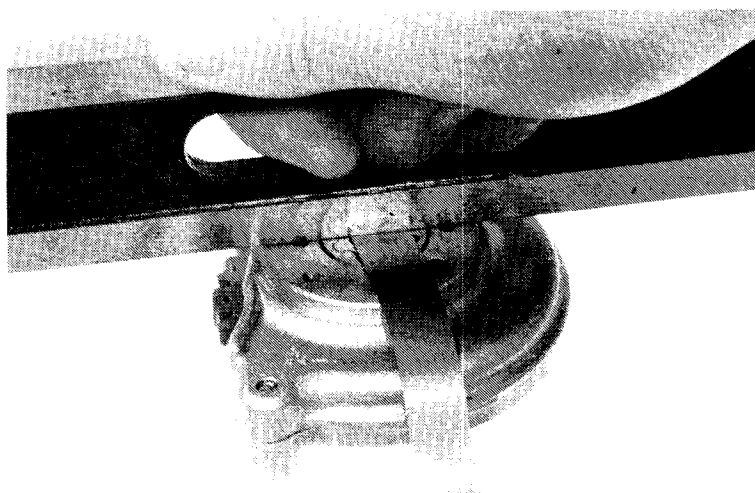

CLUTCH/OIL PUMP/GEARSHIFT LINKAGE

OIL PUMP ASSEMBLY

Install the pump drive gear on the oil pump drive shaft.

NOTE:

Align the cutout in the shaft with the cutout in the pump drive gear.

Install the oil pump shaft and gear in the body.

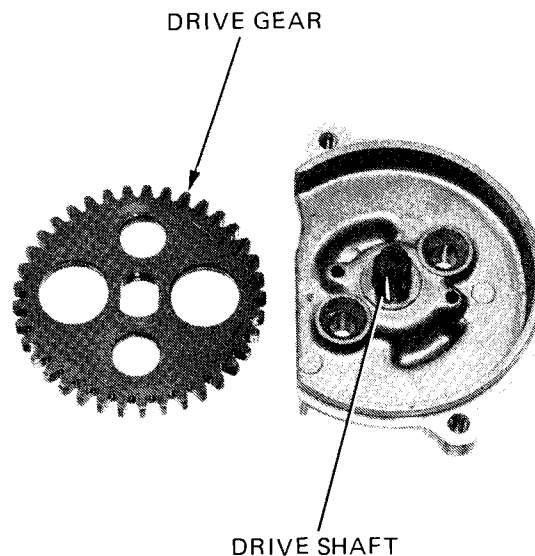

Install the inner and outer rotors and then install the pump cover.

NOTE:

Align the boss on the cover with the cutout in the pump body.

Check operation of the pump by rotating the pump gear by hand.

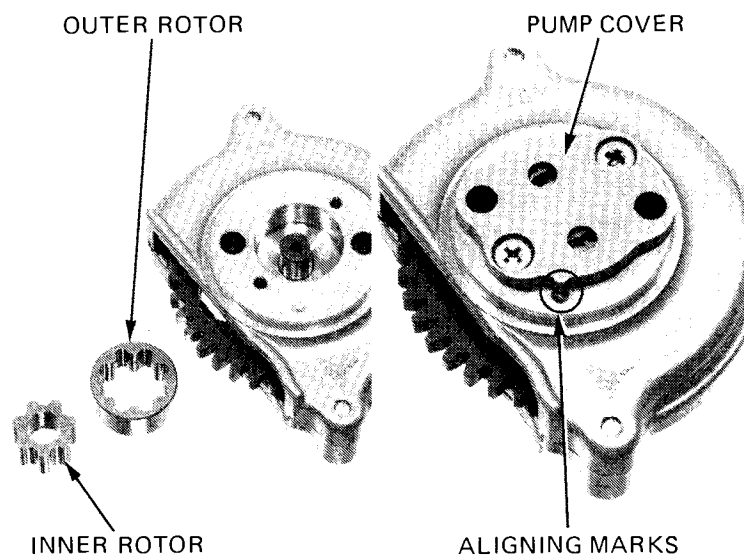

INSTALLATION

Install the O-rings.
Install the pump.

NOTE:

Make sure that the O-rings remain in place when installing the pump.

Install the oil filter rotor (page 8-8).

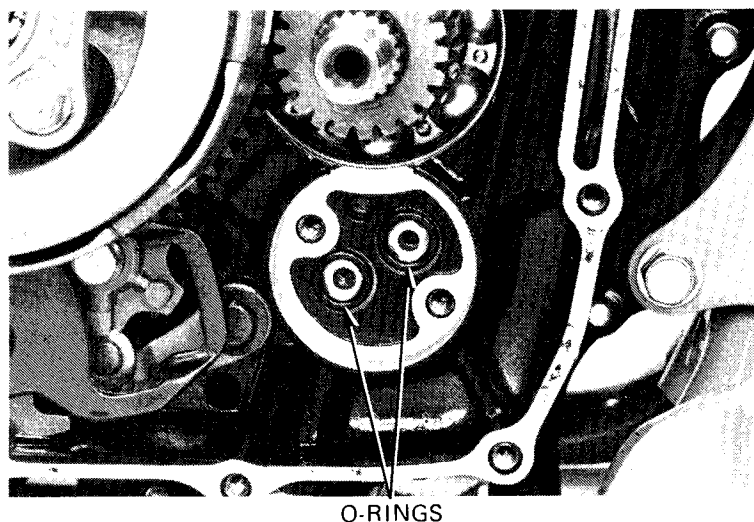

GEARSHIFT LINKAGE

DISASSEMBLY

- Remove the following:
- clutch (page 8-4).
 - oil pump (page 8-10)
 - gear shift pedal.
 - gearshift spindle.

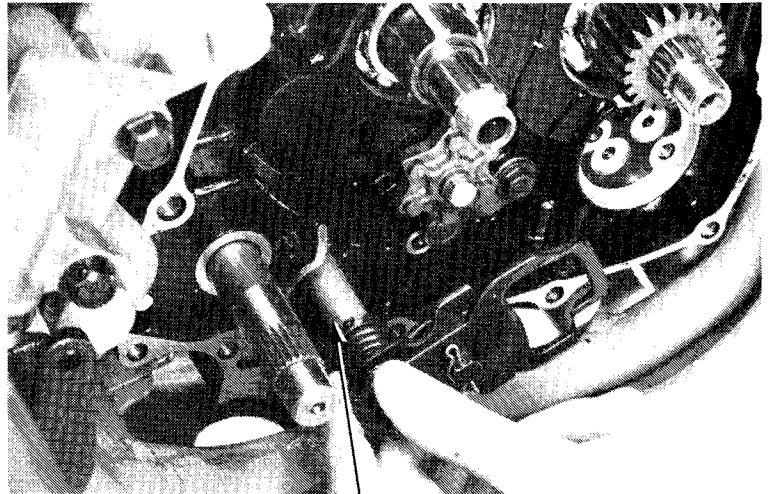

GEARSHIFT SPINDLE

- Remove the drum stopper plate.
Remove the drum stopper arm.

BOLT STOPPER PLATE

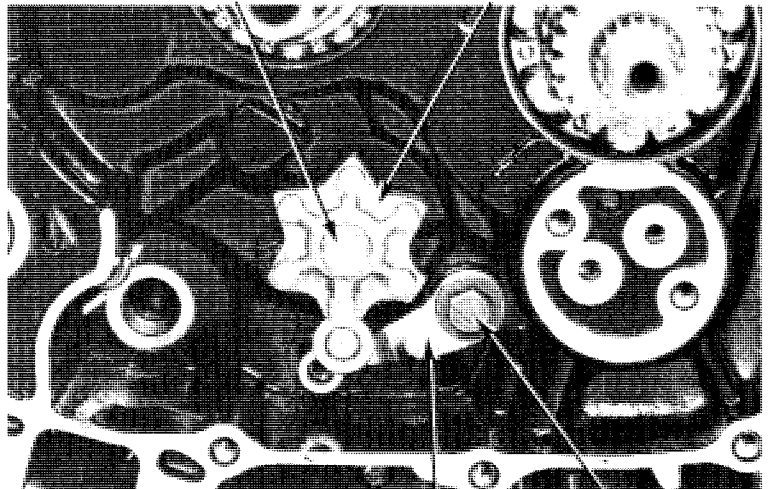

STOPPER ARM BOLT

ASSEMBLY

Assembly is essentially the reverse of disassembly.

NOTE:

- Align the hole in the stopper plate with the dowel pin.
- Attach the shift spindle return spring to the lug on the crankcase securely.

DOWEL PIN

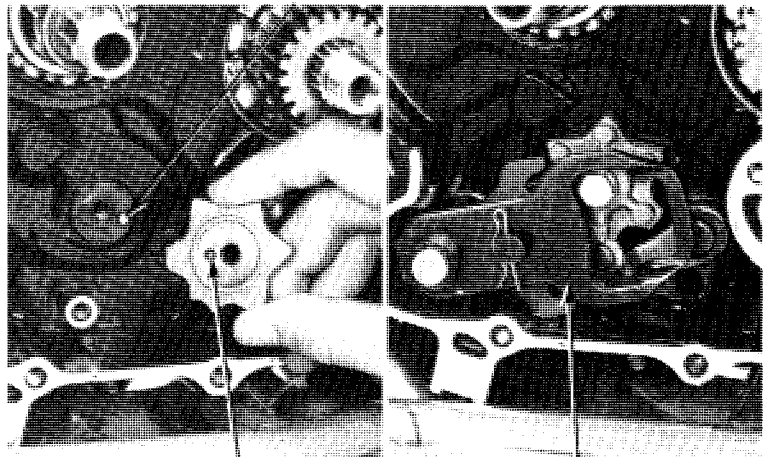

HOLE

GEARSHIFT SPINDLE

RIGHT CRANKCASE COVER INSTALLATION

Install the dowel pins and a new gasket.

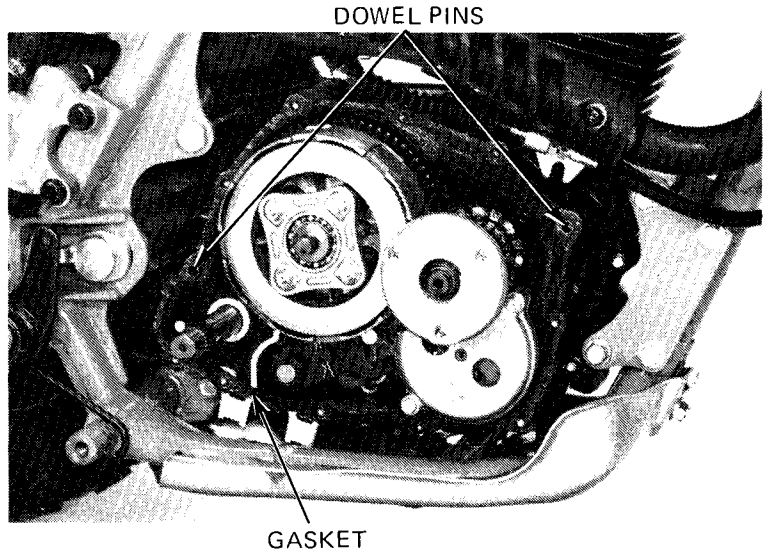

Install the right crankcase cover.

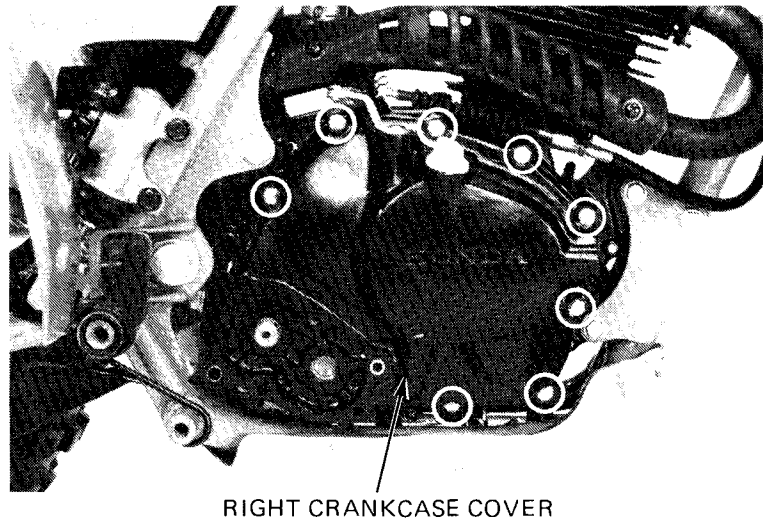

Install the kick starter driven gear onto the shaft, aligning the punch marks on the gear and shaft.

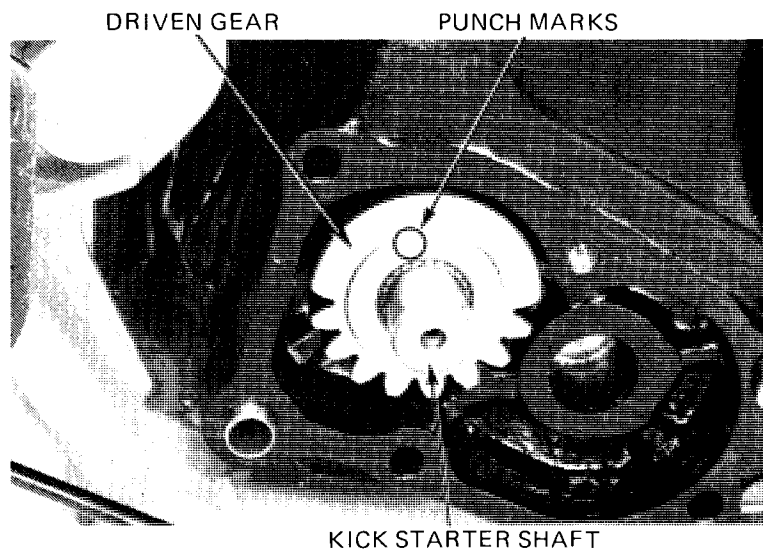

Install the kick starter drive gear onto the spindle, aligning the punch marks on the gear and spindle.

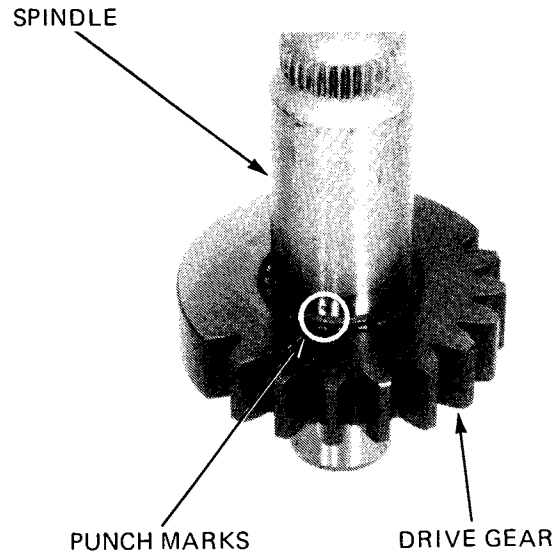

Install the thrust washers on both sides of the kick starter drive gear.

Install the kick starter drive gear and spindle in the right crankcase cover, aligning the punch marks on the kick starter drive and driven gears.

NOTE:

The drive gear diameter was changed from 50.8 ('83) to 47.9 mm (After 1983). The driven gear diameter was changed from 45.1 ('83) to 47.8 mm (After 1983). If one 1983 gear is damaged, both gears must be replaced with parts (After 1983).

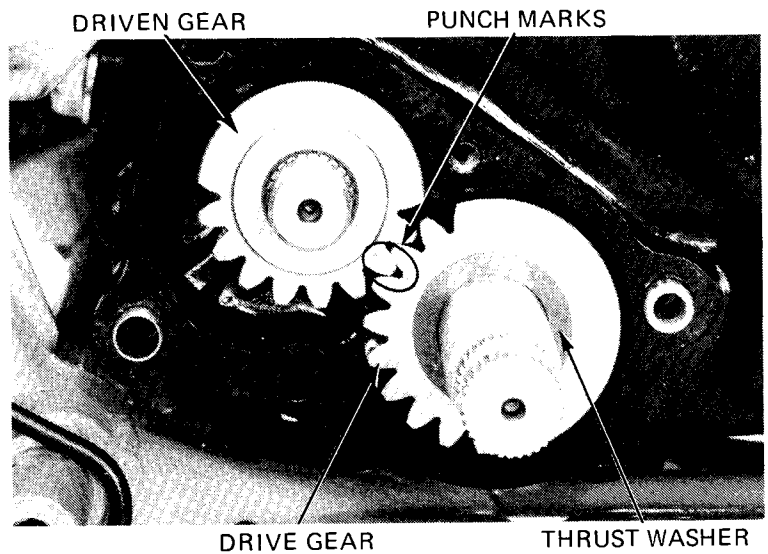

Make sure that the dowel pins are in position, and install a new gasket.

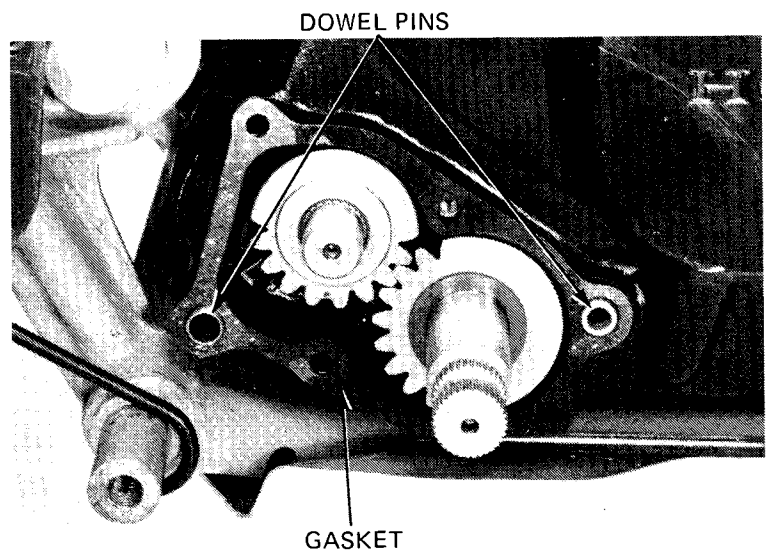

CLUTCH/OIL PUMP/GEARSHIFT LINKAGE

Apply grease to the kick starter oil seal lip and carefully install the kick starter cover, being careful not to damage the oil seal.

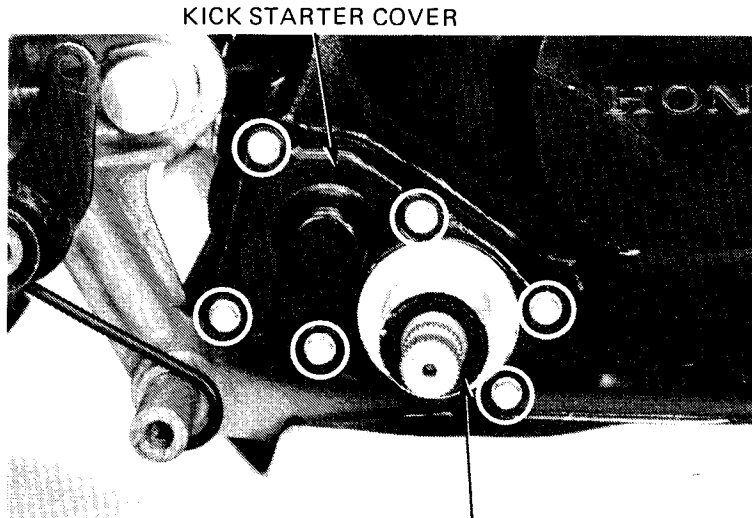

KICK STARTER COVER

OIL SEAL

Check that the rear brake pedal pivot and bearing are in good condition and coated with clean grease. Install the rear brake pedal. Connect the brake rod and arm with the joint pin. Secure the joint pin with the washer and a new cotter pin. Install the kick starter pedal.

Install the right footpeg bracket. Connect the clutch cable to the clutch arm.

Refill the crankcase to the upper level mark with the recommended oil (page 2-2).

Inspect and adjust the clutch lever free play (page 3-15).

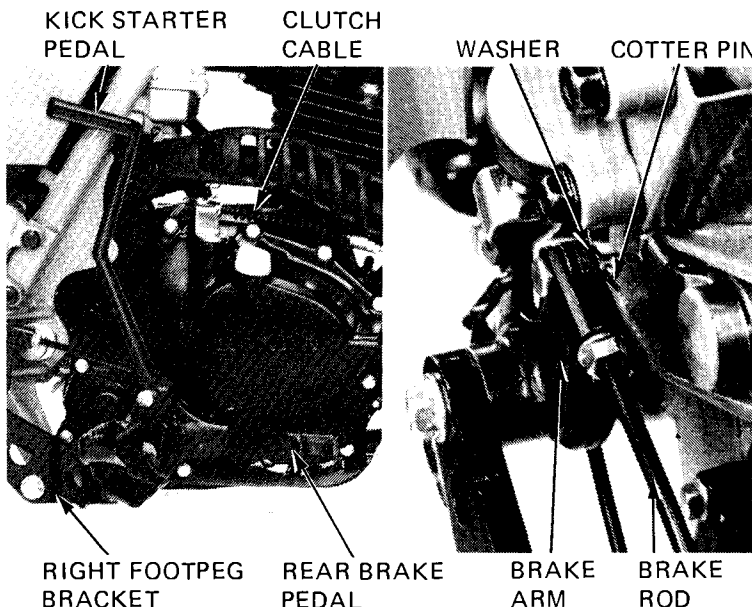

KICK STARTER PEDAL

CLUTCH CABLE

WASHER

COTTER PIN

RIGHT FOOTPEG BRACKET

REAR BRAKE PEDAL

BRAKE ARM

BRAKE ROD

MEMO

ALTERNATOR

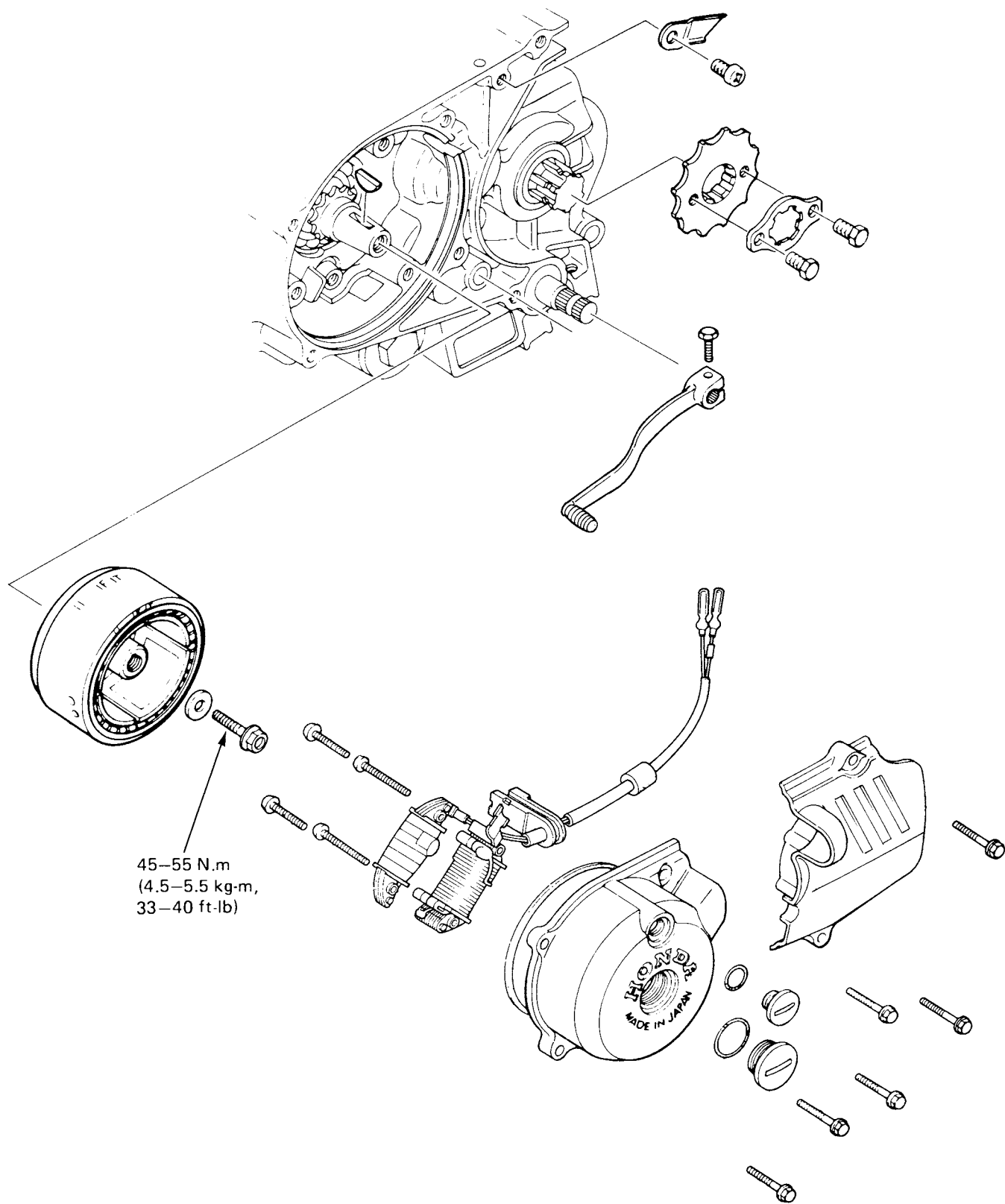

9. ALTERNATOR

SERVICE INFORMATION	9-1
LEFT CRANKCASE COVER REMOVAL	9-2
ALTERNATOR REMOVAL	9-3
ALTERNATOR INSTALLATION	9-3
LEFT CRANKCASE COVER INSTALLATION	9-4

SERVICE INFORMATION

GENERAL

- This section covers removal and installation of the alternator. These operations can be done with the engine installed after removing the left crankcase cover.
- For alternator inspection and troubleshooting, refer to section 16.

TORQUE VALUE

Rotor bolt 45–55 N·m (4.5–5.5 kg-m, 33–40 ft-lb)

TOOLS

Common

Rotor Puller 07733-0010000 or 07933-2000000
Universal Holder 07725-0030000

ALTERNATOR

LEFT CRANKCASE COVER REMOVAL

Drain oil from the engine.
Remove the gearshift pedal.
Remove the drive sprocket cover.

Remove the seat/rear fender and fuel tank.
Disconnect the alternator wire connectors.
Free the alternator wire from its clamps.
Remove the alternator wire clamp plate.

Remove the left crankcase cover.

DRIVE SPROCKET COVER

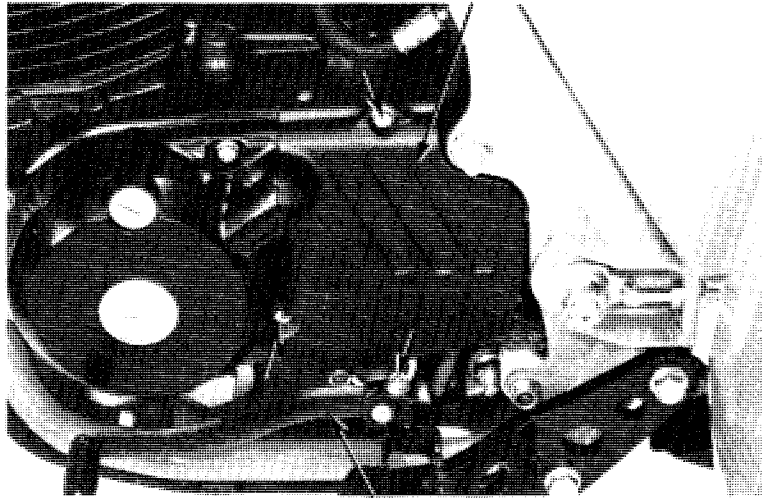

GEARSHIFT PEDAL

ALTERNATOR WIRE
CONNECTORS

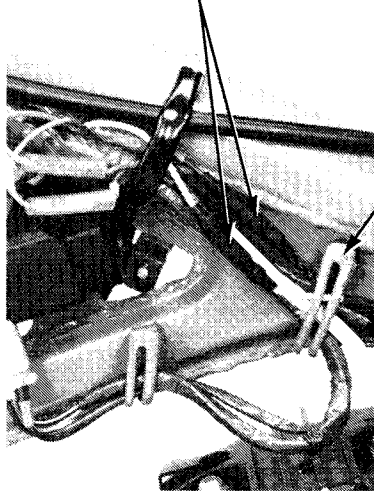

CLAMPS

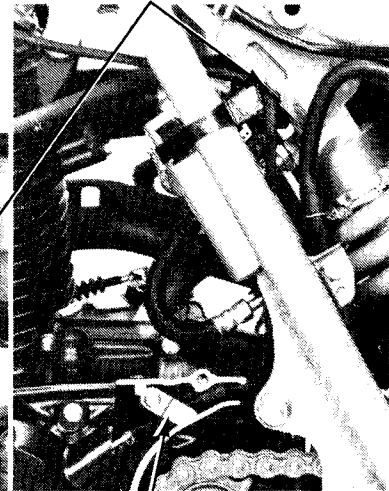

CLAMP PLATE

LEFT CRANKCASE COVER

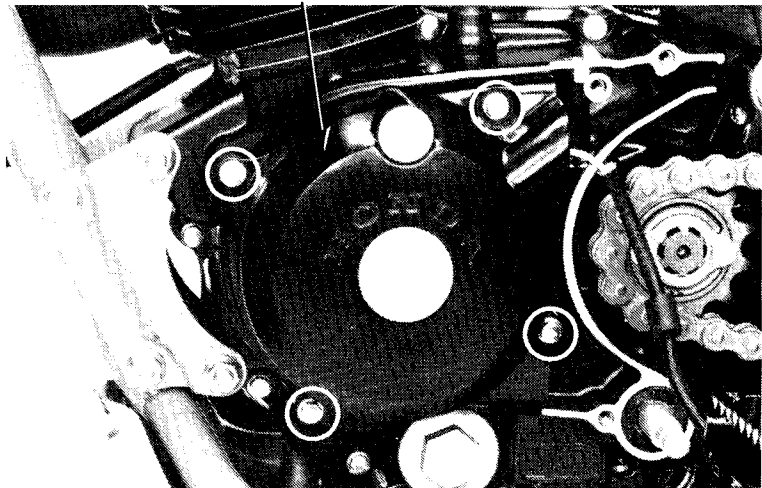

ALTERNATOR REMOVAL

Remove the drive chain and shift the transmission into top gear.

Hold the drive sprocket with a universal holder.
Remove the rotor bolt.

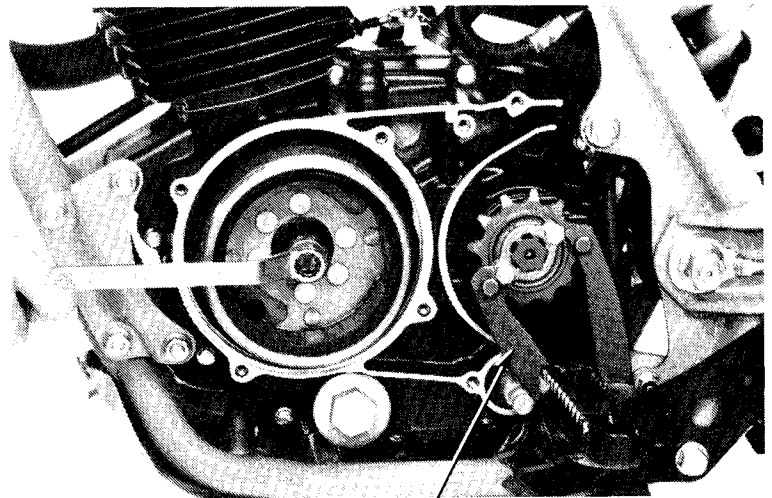

UNIVERSAL HOLDER
07725-0030000
ROTOR

Remove the rotor with a rotor puller.

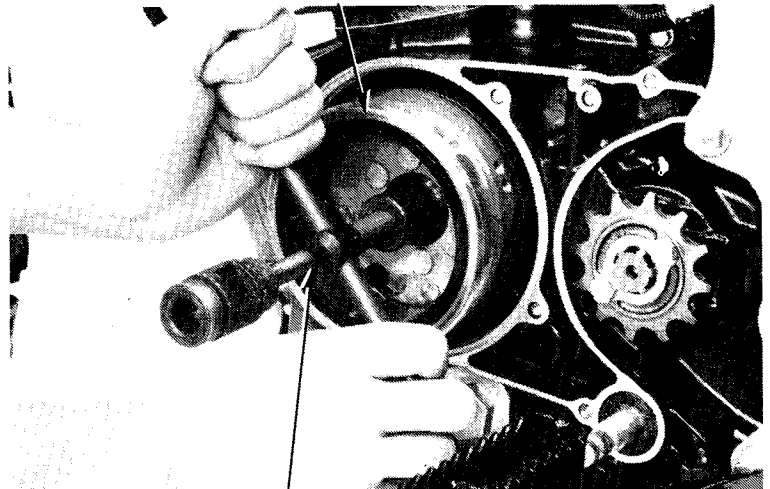

ROTOR PULLER 07733-0010000 or
07933-2000000

ALTERNATOR INSTALLATION

Install the rotor.
Install the rotor bolt and washer.

NOTE:

Align the woodruff key with the key-way in the crankshaft.

With the transmission in top gear, hold the drive sprocket with a universal holder and then tighten the rotor bolt to the specified torque.

TORQUE: 45–55 N·m (4.5–5.5 kg·m, 33–40 ft·lb)

Install the drive chain.

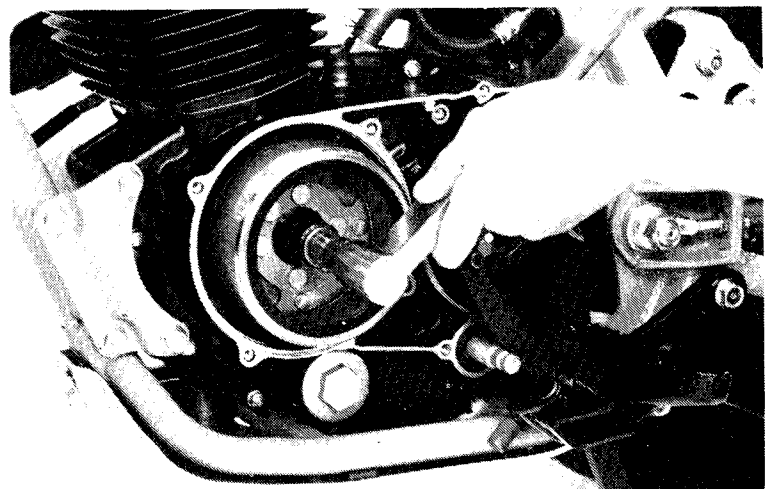

ALTERNATOR

LEFT CRANKCASE COVER INSTALLATION

Install the O-ring in the left crankcase cover.

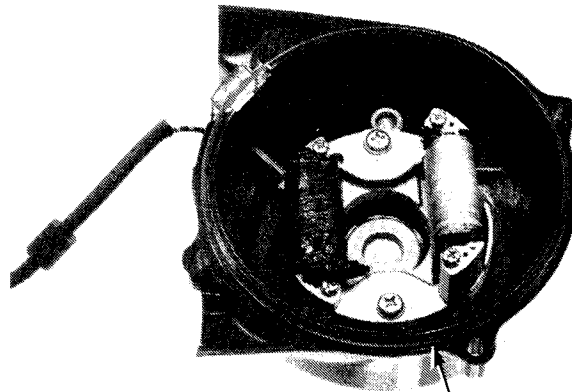

O-RING

Make sure that the rotor is clean and install the left crankcase cover.

Install the clamp plate.
Route the alternator wire properly and clamp it.
Connect the alternator wire connectors.

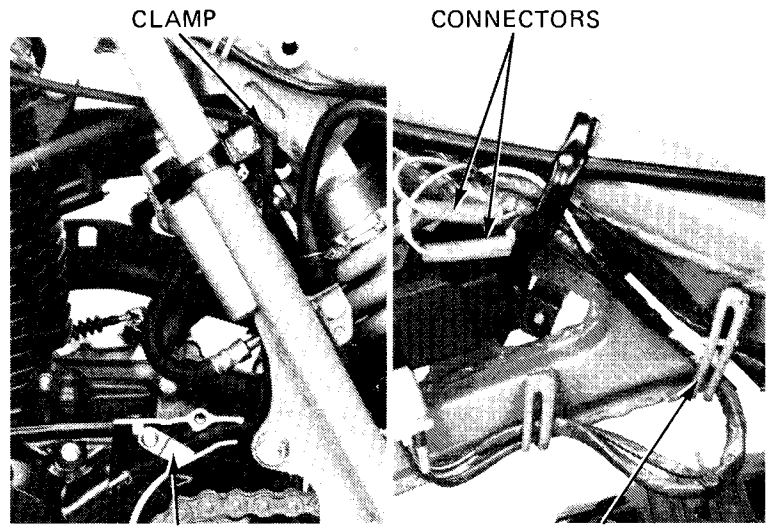

CLAMP

CONNECTORS

CLAMP PLATE

WIRE CLAMP

Install the drive sprocket cover.
Install the gearshift pedal.
Fill the engine with the recommended grade oil up to the upper level mark (page 2-2).

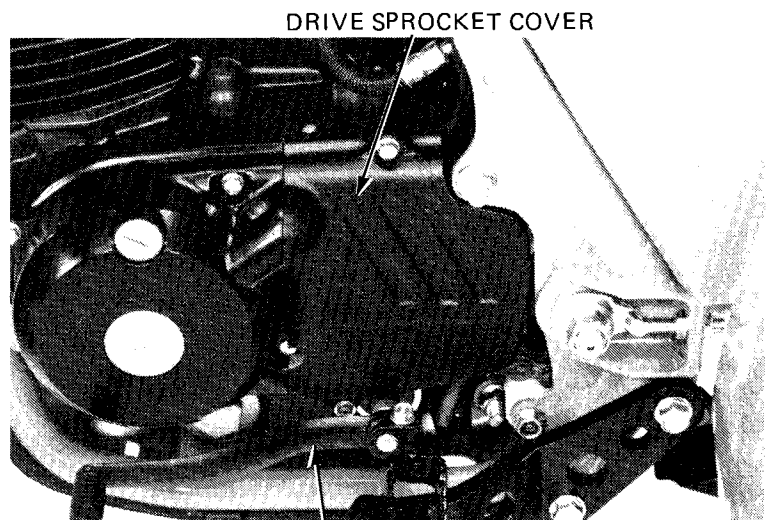

DRIVE SPROCKET COVER

GEARSHIFT PEDAL

M E M O

TRANSMISSION/CRANKSHAFT/
KICK STARTER

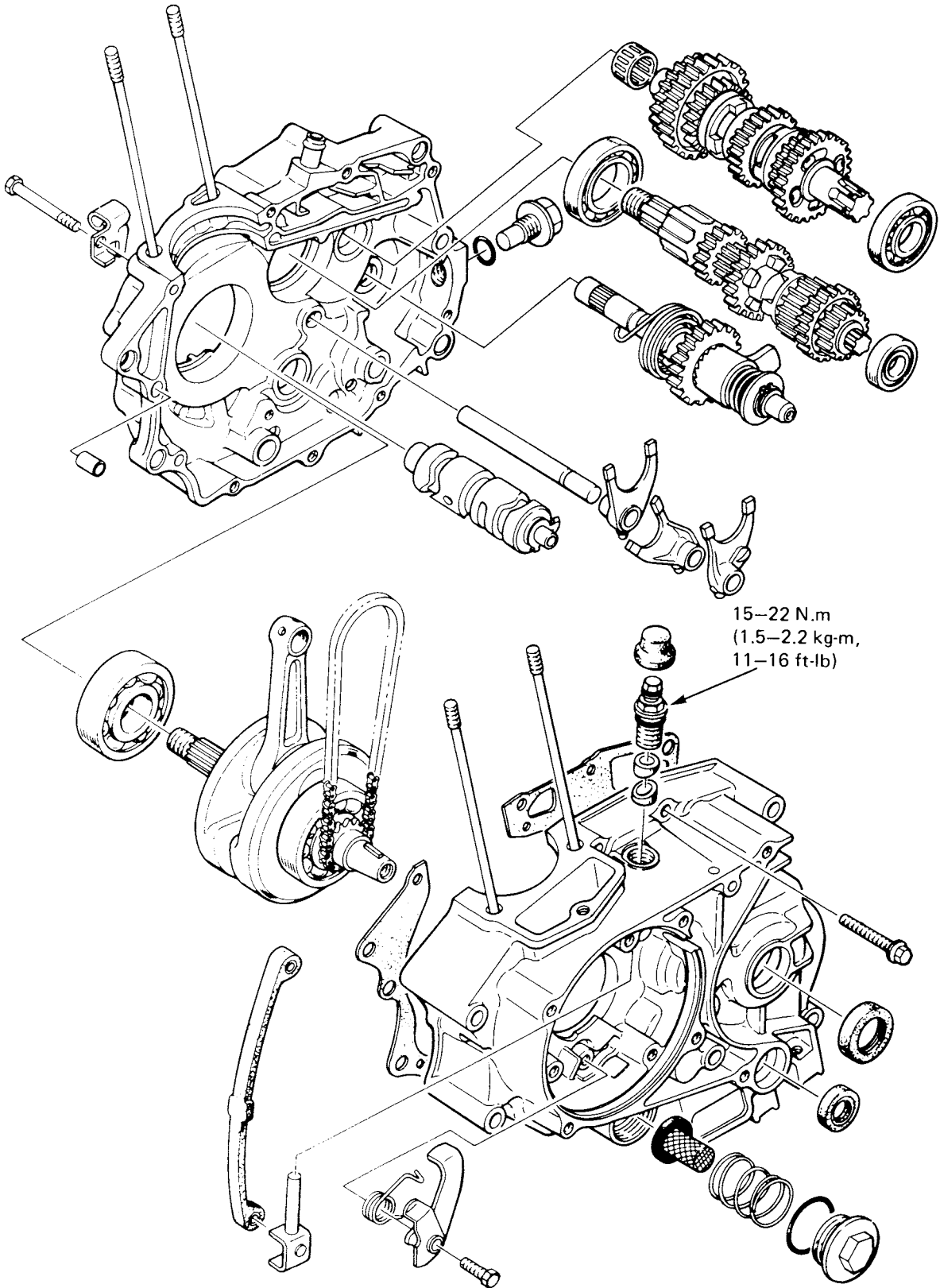

10. TRANSMISSION/CRANKSHAFT/KICK STARTER

SERVICE INFORMATION	10-1
TROUBLESHOOTING	10-1
CAM CHAIN TENSIONER	10-2
CRANKCASE SEPARATION	10-2
CRANKSHAFT	10-3
TRANSMISSION	10-5
KICK STARTER	10-10
CRANKCASE ASSEMBLY	10-12

SERVICE INFORMATION

GENERAL

- The crankcase must be separated to repair the crankshaft, transmission and kick starter. Remove the following parts before separating the crankcase:
 - Cylinder head **Section 6**
 - Cylinder and piston **Section 7**
 - Clutch and gearshift linkage **Section 8**
 - Alternator **Section 9**

SPECIFICATIONS

ITEM		STANDARD	SERVICE LIMIT
Shift fork, guide shaft	Fork	I.D.	12.000–12.018 mm (0.4724–0.4731 in)
		Claw thickness	4.93–5.00 mm (0.1941–0.1969 in)
	Shaft O.D.	11.976–11.994 mm (0.4715–0.4722 in)	11.96 mm (0.471 in)
Crankshaft	Connecting rod big end side clearance		0.05–0.50 mm (0.002–0.020 in)
	Connecting rod big end radial clearance		0.002–0.010 mm (0.0001–0.0004 in)
	Runout		—
Kick starter	Shaft O.D.	19.959–19.980 mm (0.7858–0.7866 in)	19.90 mm (0.783 in)
	Pinion I.D.	20.000–20.021 mm (0.7874–0.7882 in)	20.05 mm (0.789 in)

10

TOOLS

Common

Attachment, 52 x 55 mm	07746-0010400
Pilot, 30 mm	07746-0040700
Attachment, 32 x 35 mm	07746-0010100
Pilot, 15 mm	07746-0040300
Attachment, 42 x 47 mm	07746-0010300
Pilot, 20 mm	07746-0040500
Driver	07749-0010000

TROUBLESHOOTING

Hard to shift

- Shift fork bent.
- Shift fork shaft bent.

Transmission jumps out of gear.

- Gear dogs or slots worn.
- Shift fork bent or damaged.
- Shift fork shaft bent.

Crankshaft noisy

- Worn connecting rod big end bearing.
- Bent connecting rod.
- Worn crankshaft main journal bearing.

Gears noisy

- Worn transmission gear.
- Worn spline shafts.

CAM CHAIN TENSIONER

REMOVAL

Remove the cam chain tensioner arm.
Remove the cam chain tensioner and cam chain by
removing the adjusting bolt.

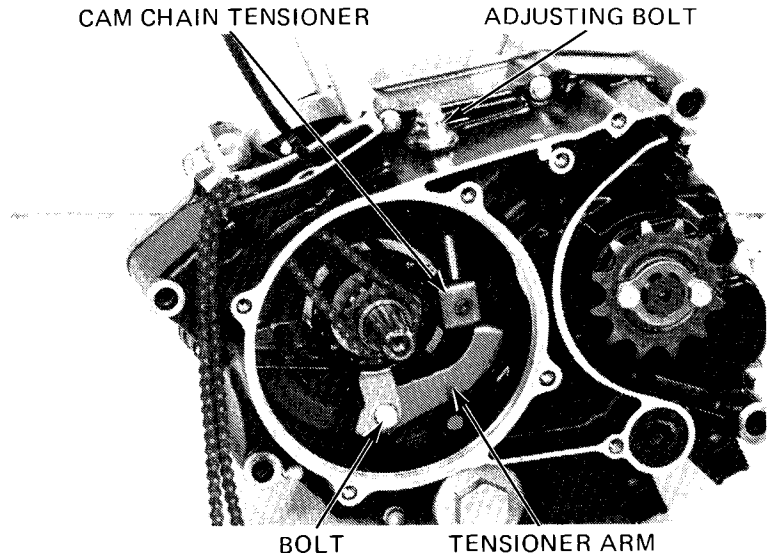

INSTALLATION

Note the direction of the lock collars and install
them on the tensioner rod.

Install the cam chain and cam chain tensioner and
then loosely install the adjusting bolt.

Install the tensioner arm. Hold the tensioner arm
down all the way and then tighten the adjusting
bolt.

TORQUE: 15–22 N·m (1.5–2.2 kg·m, 11–16 ft·lb)

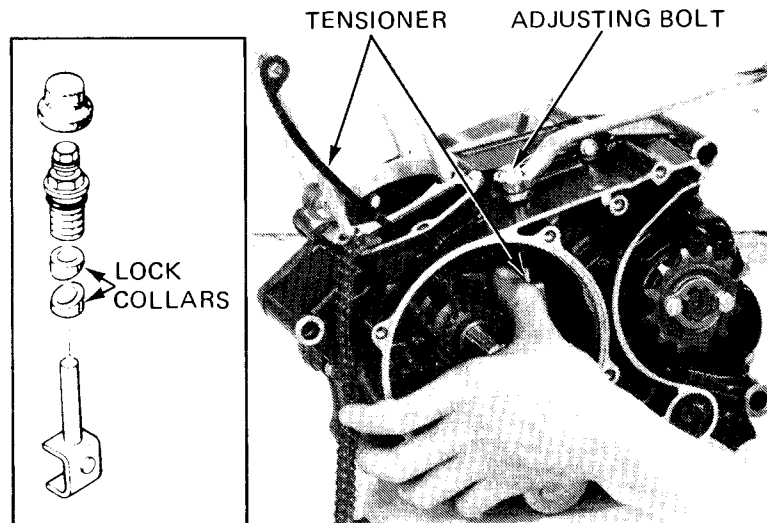

CRANKCASE SEPARATION

Remove the cam chain tensioner arm and the cam
chain.

Remove the left crankcase 6 mm bolts.

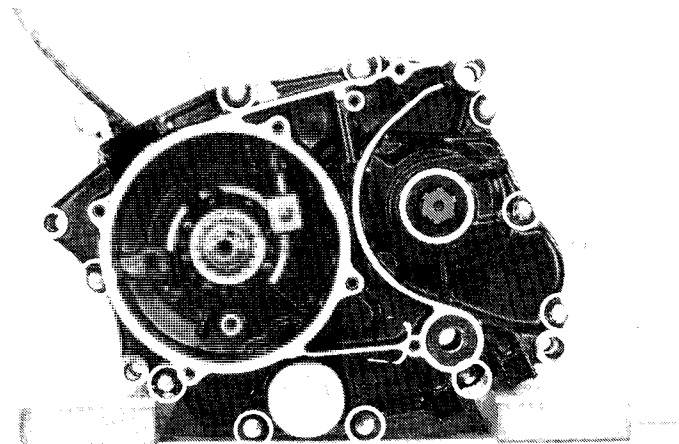

Set the engine on the left crankcase.
Remove the clutch cable holder bolt.
Separate the right crankcase from the left crankcase.

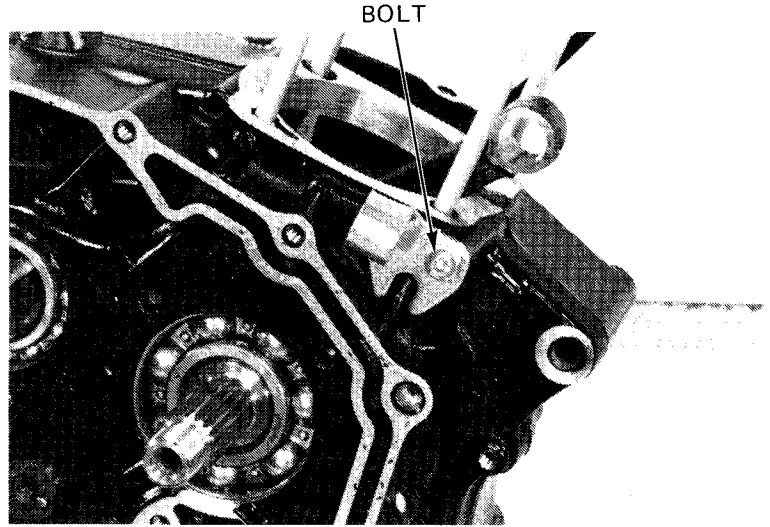

CRANKSHAFT

REMOVAL

Remove the dowel pins and gasket.
Remove the crankshaft.

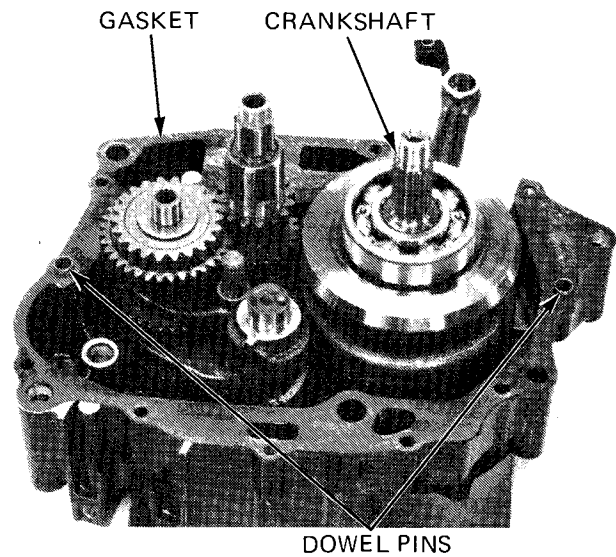

INSPECTION

Measure the side clearance at the connecting rod big end with a feeler gauge.

SERVICE LIMIT: 0.80 mm (0.032 in)

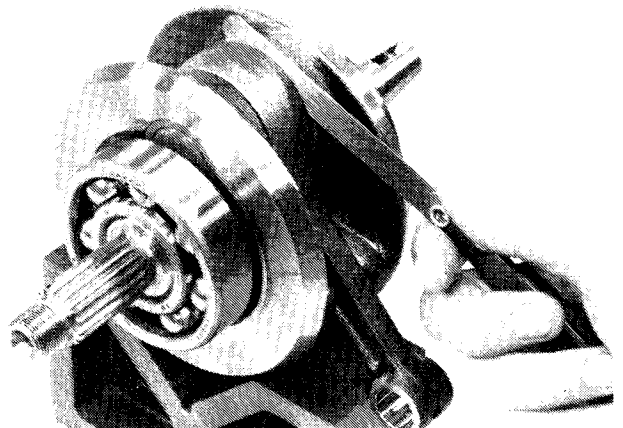

TRANSMISSION/CRANKSHAFT/ KICK STARTER

Measure the radial clearance at the connecting rod big end, at two points in the direction indicated by the arrows:

SERVICE LIMIT: 0.05 mm (0.02 in)

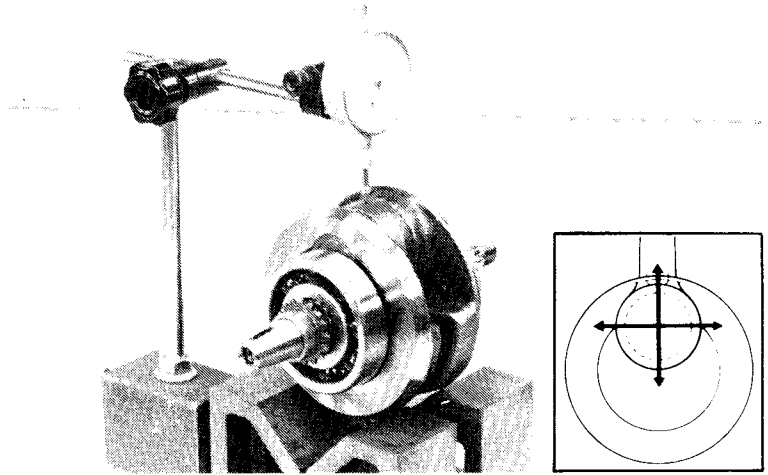

Set the crankshaft on a stand or V-blocks and read the runout using a dial indicator.

SERVICE LIMIT: 0.05 mm (0.002 in)

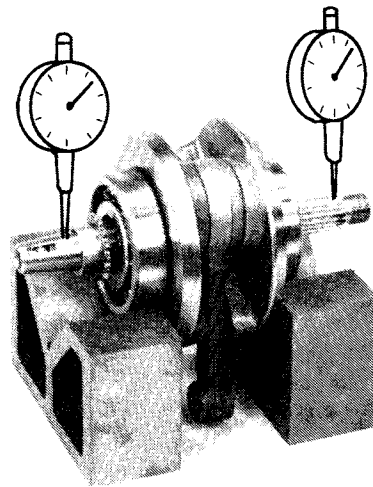

CRANKSHAFT BEARING INSPECTION

Spin the crankshaft bearing by hand and check for play.

The bearing must be replaced if it is noisy or has excessive play.

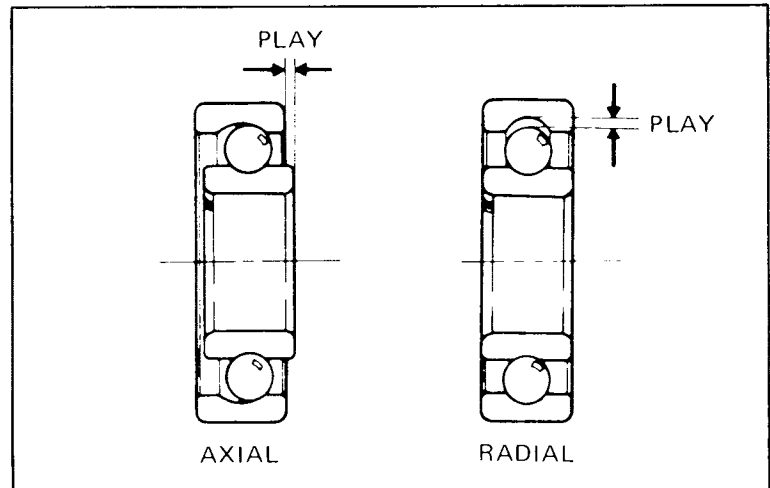

TIMING SPROCKET INSTALLATION

Install the sprocket, aligning any tooth center with the keyway in the crankshaft.

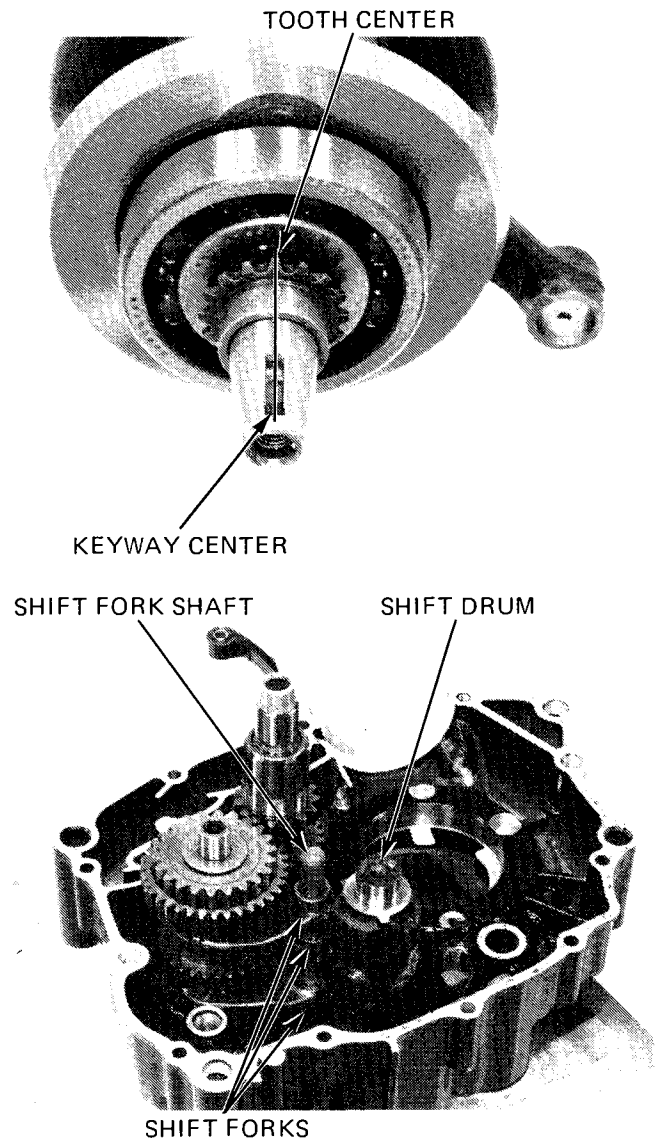

TRANSMISSION

DISASSEMBLY

Remove the shift fork shaft and remove the shift forks.

Remove the shift drum.

Remove the transmission.

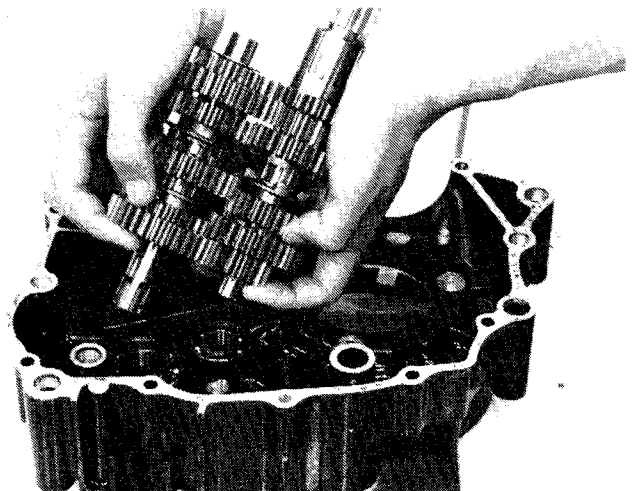

TRANSMISSION/CRANKSHAFT/ KICK STARTER

INSPECTION

● SHIFT FORK/SHIFT SHAFT

Check the shift fork for wear, bending or any damage.

Measure the I.D.

SERVICE LIMIT: 12.05 mm (0.474 in)

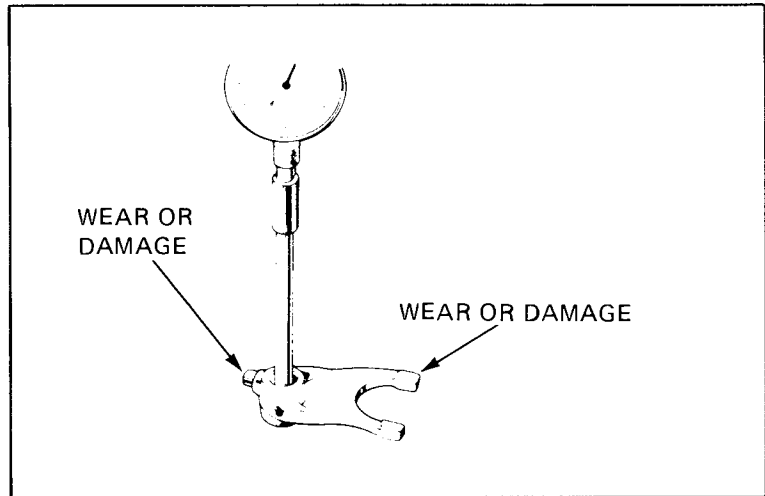

Measure the shift fork claw thickness.

SERVICE LIMIT: 4.50 mm (0.177 in)

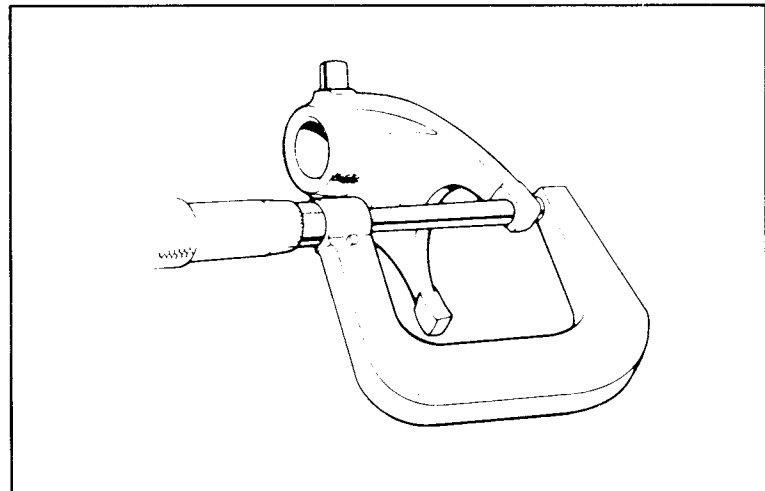

Measure the shift fork shaft O.D.

SERVICE LIMIT: 11.96 mm (0.471 in)

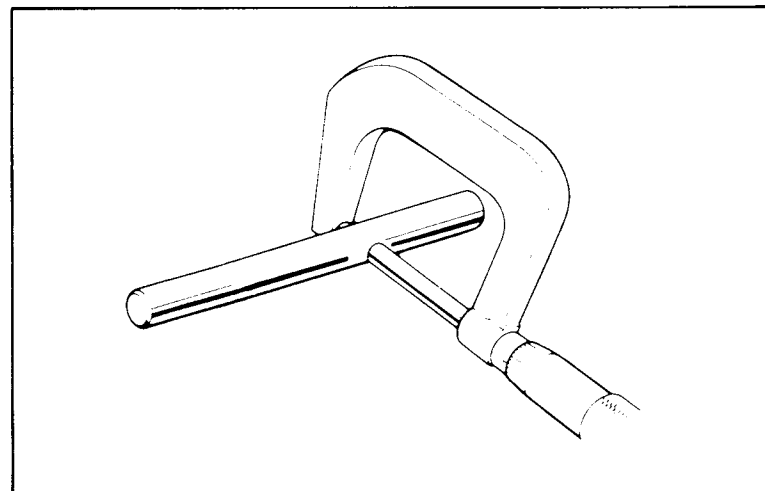

● TRANSMISSION GEAR

Inspect each gear for wear or damage and replace if necessary.

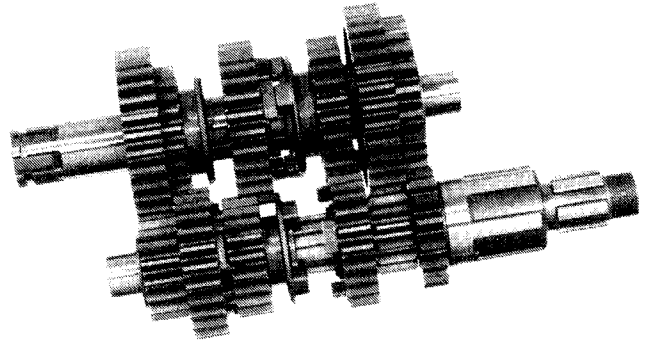

● CRANKCASE BEARING

Spin the bearing by hand and check for play. The bearings must be replaced if it is noisy or have excessive play.

BALL BEARINGS

BALL BEARING

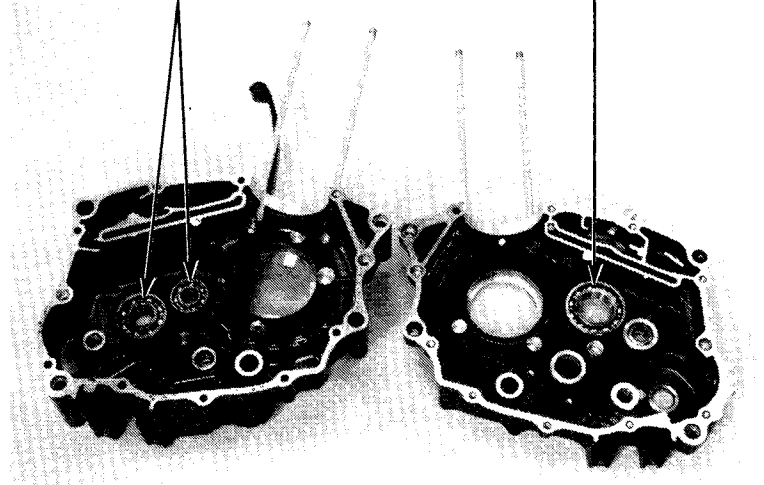

CRANKCASE BEARING REPLACEMENT

Install the bearings with the manufacturer's marking up.

- Right crankcase mainshaft bearing
 - Attachment, 52 x 55 mm: 07746-0010400
 - Pilot, 30 mm: 07746-0040700
- Left crankcase mainshaft bearing
 - Attachment, 32 x 35 mm: 07746-0010100
 - Pilot, 15 mm: 07746-0040300
- Left crankcase countershaft bearing
 - Attachment, 42 x 47 mm: 07746-0010300
 - Pilot, 20 mm: 07746-0040500

DRIVER
07749-0010000



ATTACHMENT AND PILOT

TRANSMISSION/ CRANKSHAFT/KICK STARTER

ASSEMBLY

Coat all parts with oil.

Assemble the transmission shafts and gears, noting the locations of the thrust washers and snap rings.

NOTE:

Make sure the snap rings are seated properly.

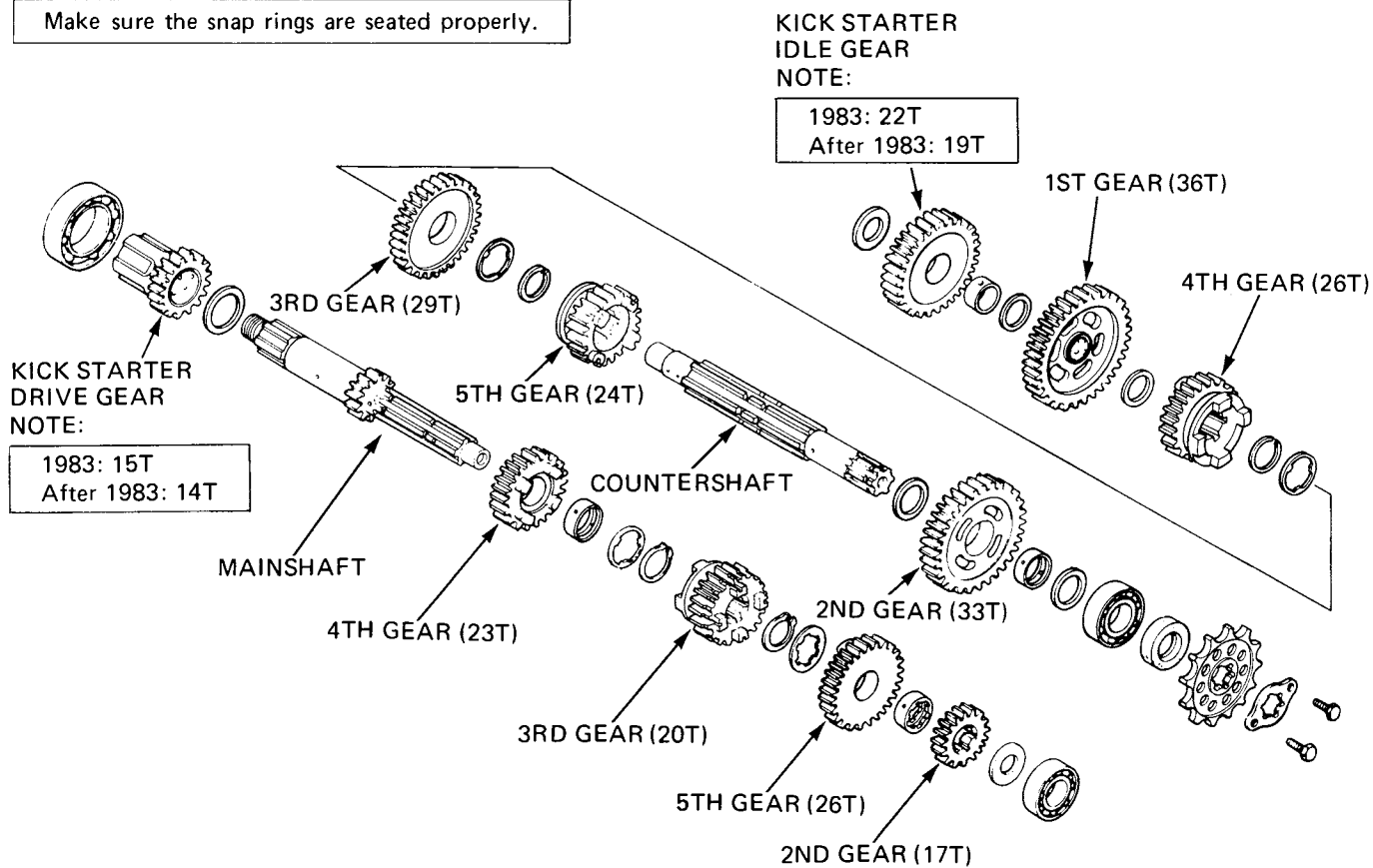

Assemble the mainshaft and countershaft.

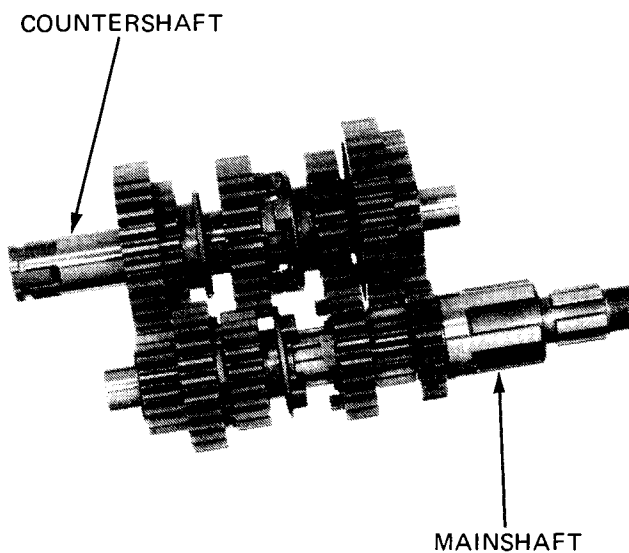

Install the mainshaft and countershaft assemblies in the left crankcase.

NOTE:

Make sure the thrust washer stays in place during this operation.

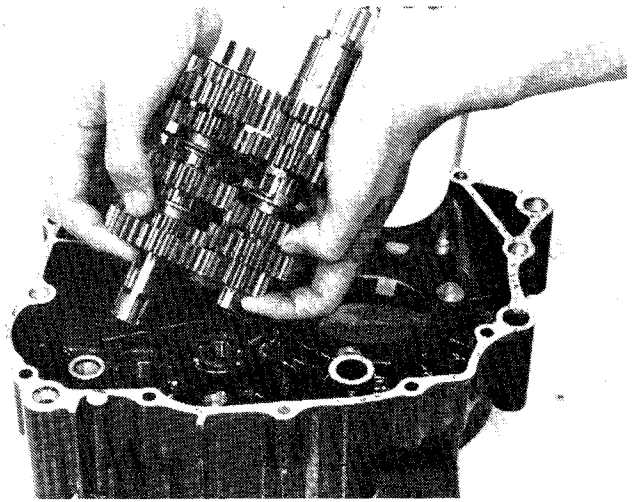

Install the shift drum and shift forks.

NOTE:

- Note the installation positions of the shift forks.
- Install the center shift fork with the marking "C" facing up. Install the left and right shift forks with the marking "L" and "R" facing down.

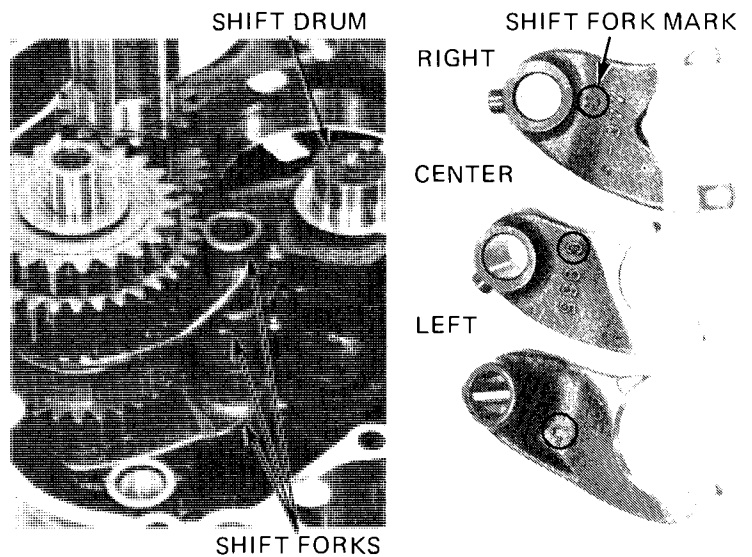

Install the shift fork shaft.

Rotate the mainshaft by hand to see if the gears rotate freely.

NOTE:

Make sure the transmission gears are in the neutral position.

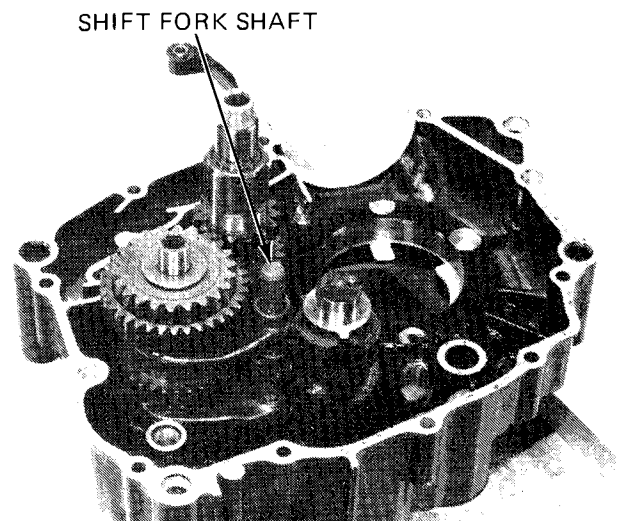

KICK STARTER

DISASSEMBLY

Remove the thrust washer.
Back off the stopper bolt and remove the kick starter.

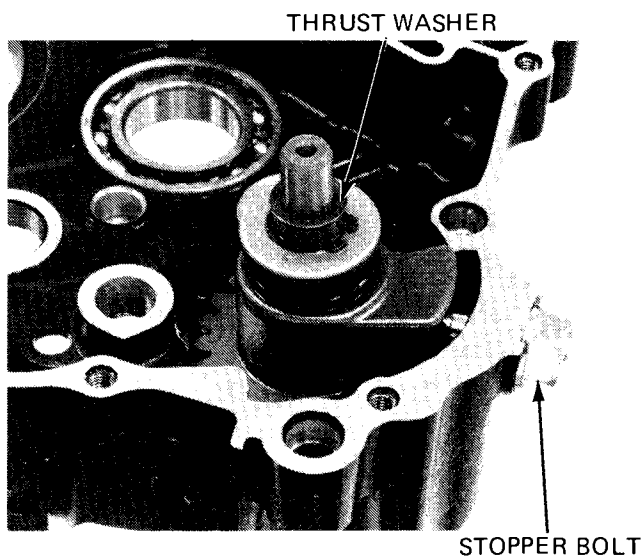

Remove the collar, return spring and guide plate.

Remove the starter pinion gear, thrust washer and 20 mm snap ring.

Remove the 18 mm snap ring, spring seat, ratchet spring and drive ratchet.

Inspect the ratchet for wear, nicks, or cracks.

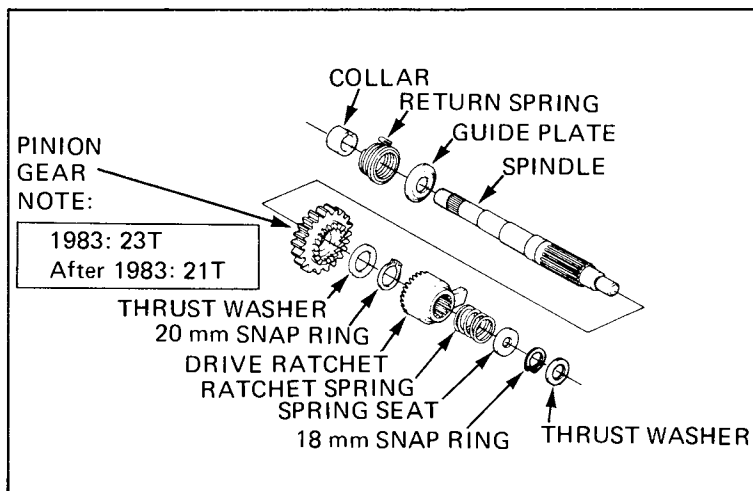

INSPECTION

● KICK STARTER PINION

Measure the pinion I.D.

SERVICE LIMIT: 20.05 mm (0.789 in)

Inspect the pinion gear for worn or chipped teeth.

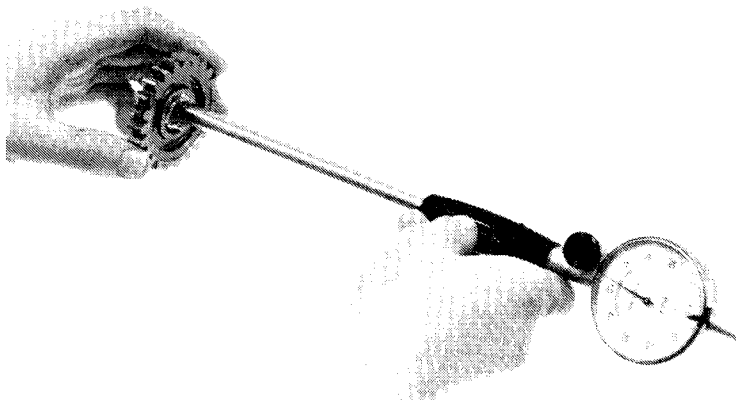

● KICK STARTER SHAFT

Measure the O.D. of the pinion gear sliding surface.

SERVICE LIMIT: 19.90 mm (0.783 in)

Inspect the shaft for scoring or nicks.

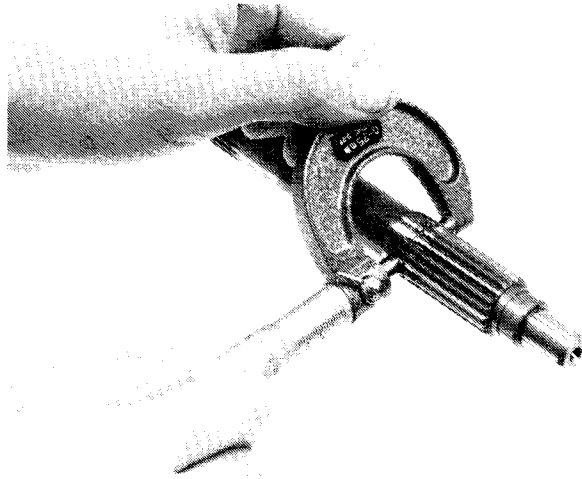

ASSEMBLY

Install the starter pinion, thrust washer and 20 mm snap ring on the shaft.

Install the drive ratchet.

NOTE:

Align the shaft punch mark with the drive ratchet punch mark.

Install the ratchet spring, spring seat and 18 mm snap ring.

Install the guide plate, spring and collar.

NOTE:

Align the collar groove with the spring.

Install the kick starter.

NOTE:

Hook the end of the return spring over the right crankcase as shown.

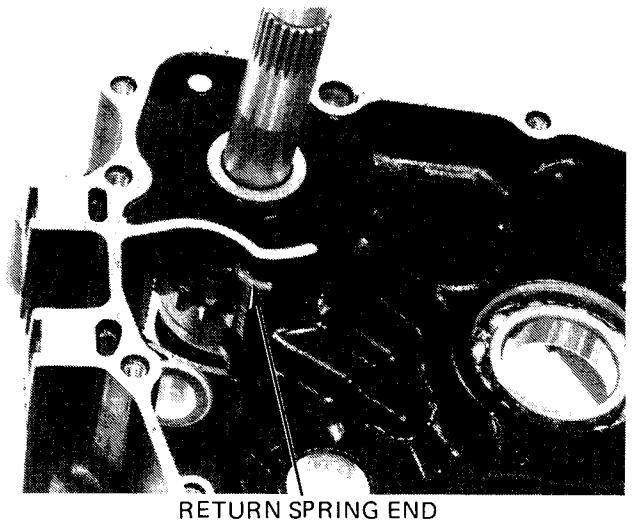
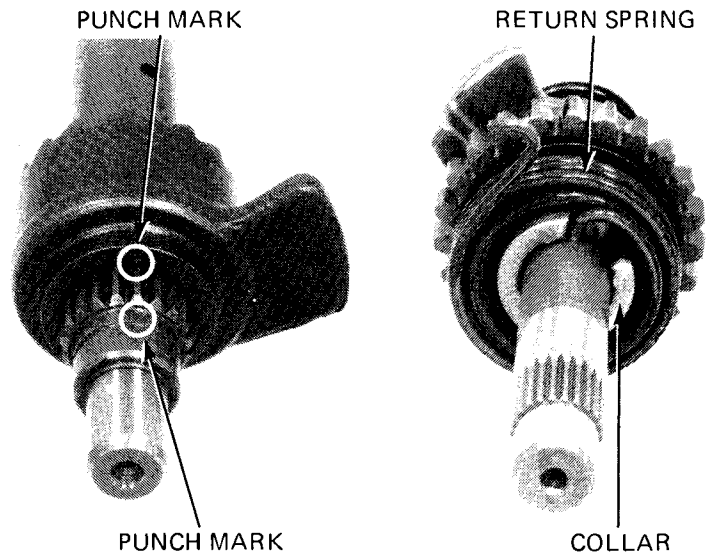

TRANSMISSION/CRANKSHAFT/ KICK STARTER

Install the O-ring on the stopper bolt.

Install the kick starter driven gear onto the shaft and rotate the shaft.

Install the stopper bolt and align the drive ratchet boss with the top of the stopper bolt.

NOTE:

Do not forget to install the O-ring.

Remove the kick starter driven gear.

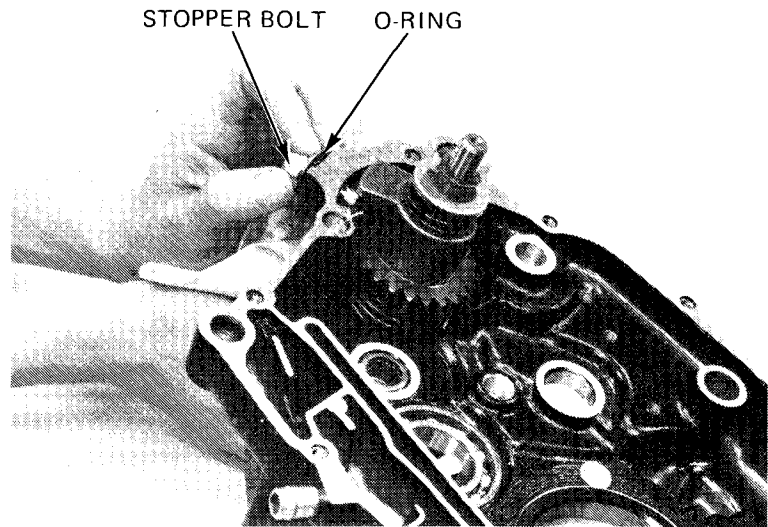

Tighten the stopper bolt securely.
Install the thrust washer on the shaft.

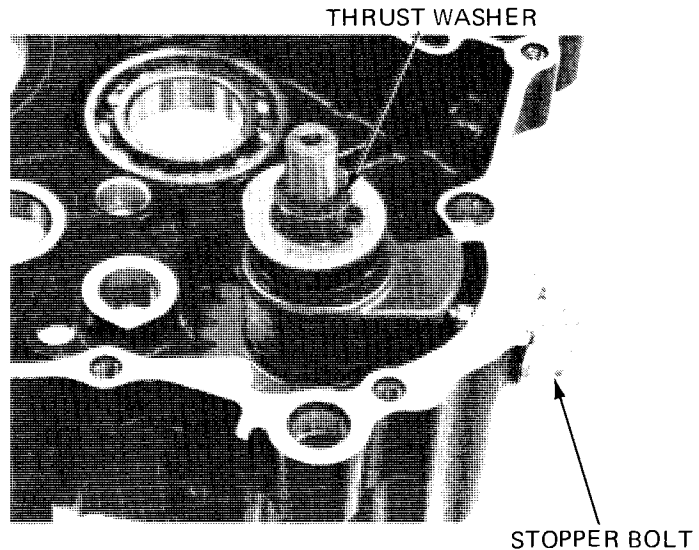

CRANKCASE ASSEMBLY

Install the crankshaft in the left crankcase.
Install the gasket and dowel pins.

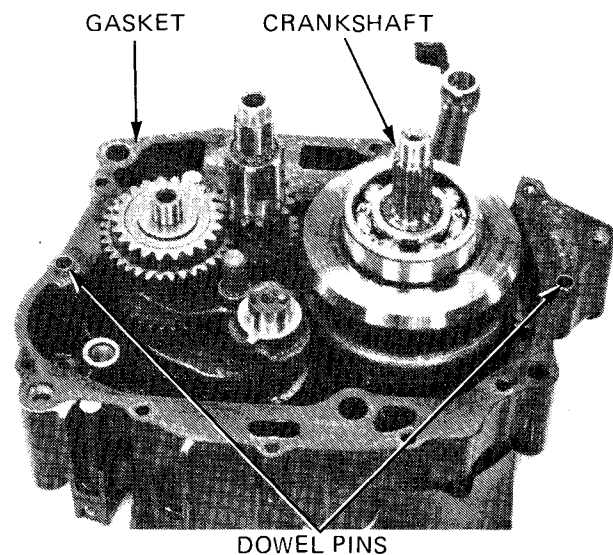

Install the right crankcase on the left crankcase while turning the kick starter shaft as shown.

NOTE:

Make sure that the gasket stays in place during this operation.

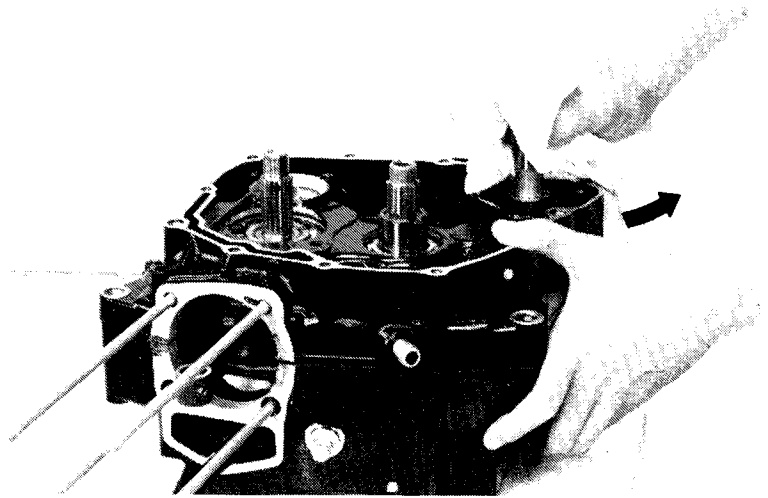

Install the clutch cable holder to the right crankcase.

Lay the engine on its right crankcase and tighten the 6 mm bolts securely.

NOTE:

Tighten the bolts in a crisscross pattern in 2-3 steps.

After tightening, check that the gears rotate freely.

Install the kick starter driven gear onto the spindle and check the operation.

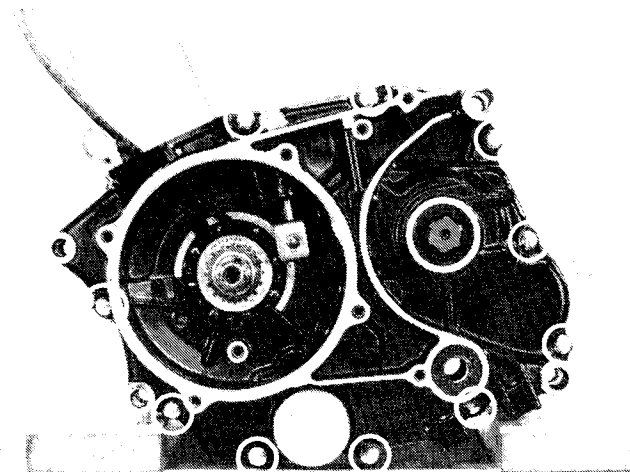

FRONT WHEEL/FRONT FORK/STEERING

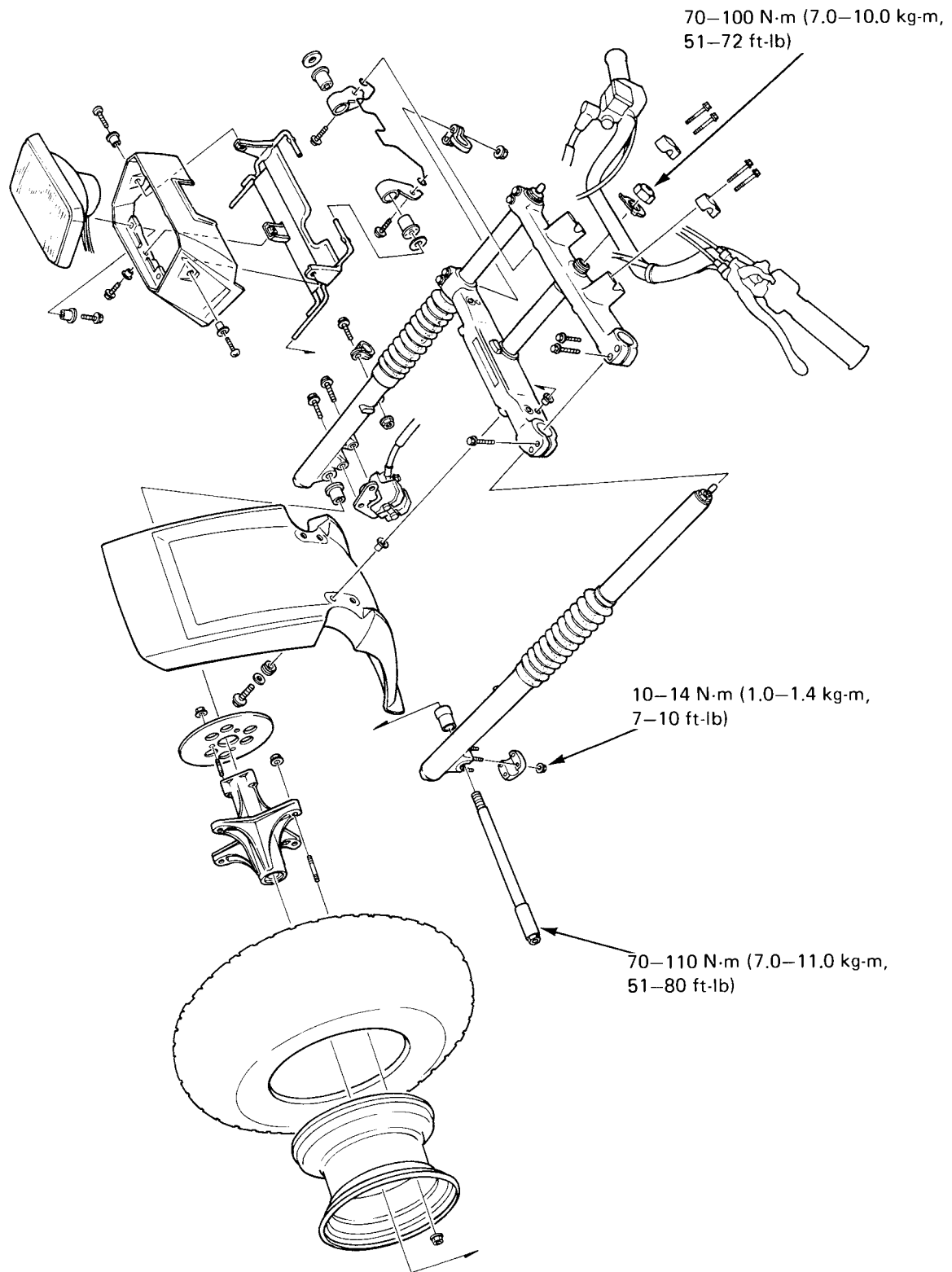

11. FRONT WHEEL/FRONT FORK/STEERING

SERVICE INFORMATION	11-1
TROUBLESHOOTING	11-2
HEADLIGHT	11-3
HANDLEBAR	11-7
FRONT WHEEL	11-10
FRONT FORK	11-18
STEERING STEM	11-26

SERVICE INFORMATION

GENERAL

- This section covers maintenance of the front wheel, front fork and steering system.
- A jack or other support is required to support the ATC.

SPECIFICATIONS

ITEM		STANDARD	SERVICE LIMIT
Front axle runout		0.3 mm (0.01 in)	0.5 mm (0.02 in)
Front fork spring free length	A	149.4 mm (5.88 in)	145 mm (5.7 in)
	B	397.7 mm (15.66 in)	390 mm (15.4 in)
Front fork tube runout		—	0.20 mm (0.008 in)
Front wheel rim runout	Radial	—	1.5 mm (0.06 in)
	Axial	—	2.0 mm (0.08 in)

11

TORQUE VALUES

Steering stem nut		70–100 N·m (7.0–10.0 kg-m, 51–72 ft-lb)
Steering top thread nut	Initial:	25–35 N·m (2.5–3.5 kg-m, 18–25 ft-lb)
	Final:	5.5–6.5 N·m (0.55–0.65 kg-m, 4.0–4.7 ft-lb)

FRONT WHEEL/FRONT FORK/STEERING

TOOLS

Special

Hex. Wrench, 6 mm	07917-3230000 or Equivalent tool commercially available in U.S.A.
Tire Disassembling Tool	GN-AH-958-BBI (U.S.A. only)
Race Remover	07953-3330000
Steering Stem Driver	07946-4300001 or 07946-3710600 (U.S.A. only)
Steering Stem Driver Attachment	GN-HT-54 (U.S.A. only)

Common

Pin Spanner	07702-0010000 or M9361-412-099788 (U.S.A. only)
Lock Nut Wrench, 30 x 32 mm	07716-0020400 or Equivalent tool commercially available in U.S.A.
Extension	07716-0020500 or Equivalent tool commercially available in U.S.A.
Attachment, 42 x 47 mm	07746-0010300
Pilot, 15 mm	07746-0040300
Fork Seal Driver Body	07747-0010100
Attachment (D)	07747-0010500 or 07947-3330000 (U.S.A. only)
Driver	07749-0010000

TROUBLESHOOTING

Hard steering

1. Steering stem nut too tight.
2. Faulty steering stem bearings.
3. Damaged steering stem ball race and/or cone race.
4. Insufficient tire pressure.

Steers to one side or does not track straight

1. Bent front forks.
2. Bent front axle, wheel installed incorrectly.
3. Unequal rear tire pressure or circumference.

Front wheel wobbling

1. Bent rim.
2. Worn front wheel bearing.
3. Faulty tire.
4. Axle not tightened properly.

Soft suspension

1. Weak fork springs.
2. Insufficient fluid/air in front forks.

Hard suspension

1. Incorrect fluid/air in front forks.
2. Fork damaged.

Front suspension noise

1. Slider binding.
2. Loose front fork fasteners.
3. Insufficient fluid in forks.

HEADLIGHT

HEADLIGHT CASE REMOVAL

Remove the two screws and bolt attaching the headlight case to the headlight case brackets.

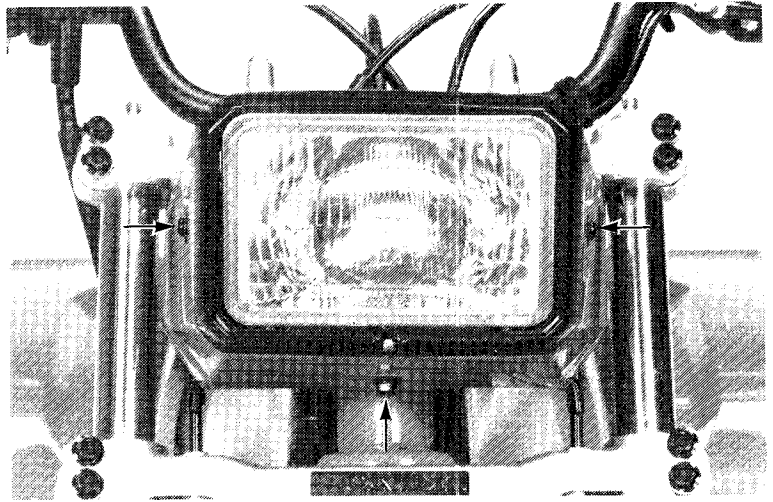

Disconnect the headlight coupler from the headlight and remove the headlight and case as an assembly.

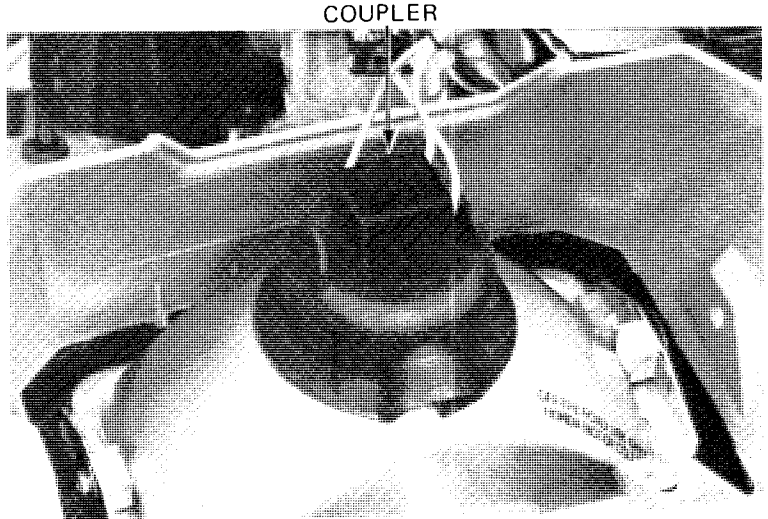

Separate the headlight from the headlight case by removing the two screws.

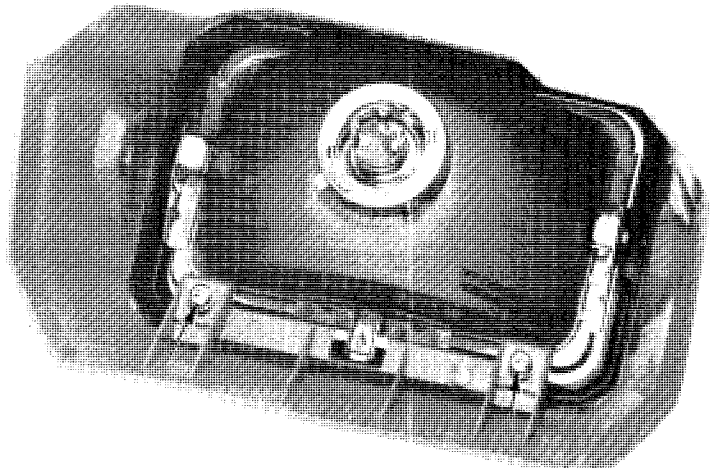

FRONT WHEEL/FRONT FORK/STEERING

HEADLIGHT DISASSEMBLY

Disassemble the headlight.

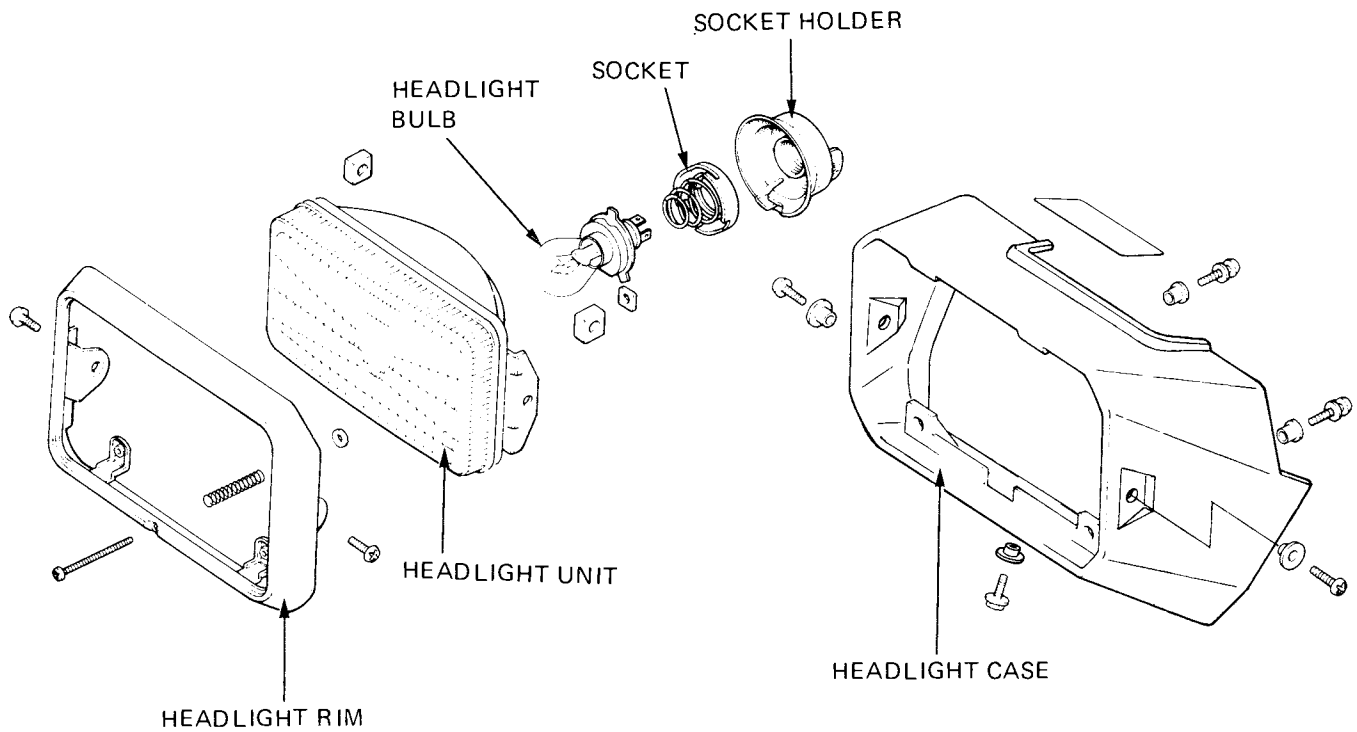

HEADLIGHT CASE INSTALLATION

Position the headlight on the headlight case, engaging the lugs of the case with the tabs of the headlight.

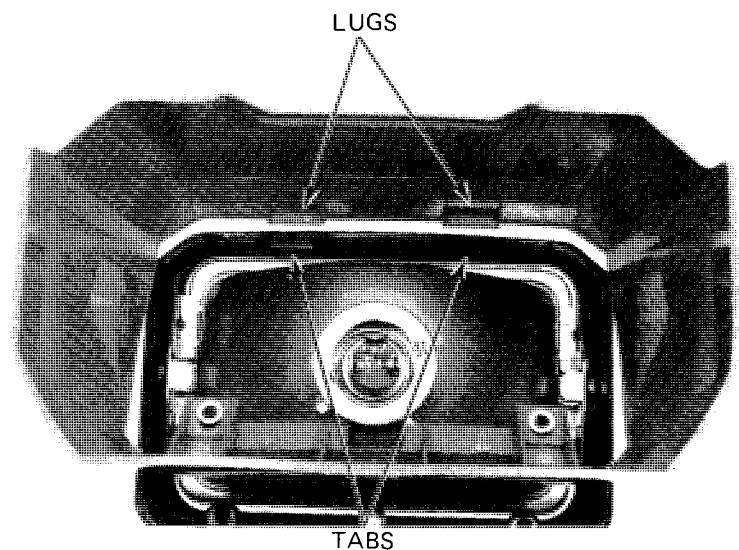

Install the headlight using the two screws.
Install the bulb in the headlight with the lugs of the bulb aligned with the cutouts of the headlight.

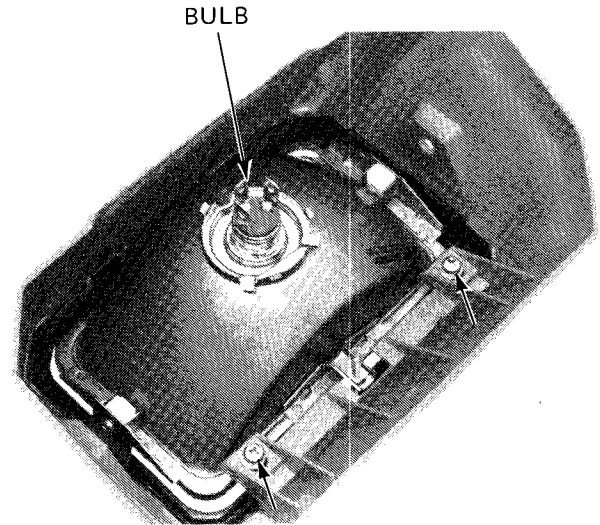

Place the headlight bulb socket spring over the bulb.

Install the bulb socket on the bulb by aligning the grooves with the lugs of the bulb and turning it in the direction of the arrow while pressing it down by hand.

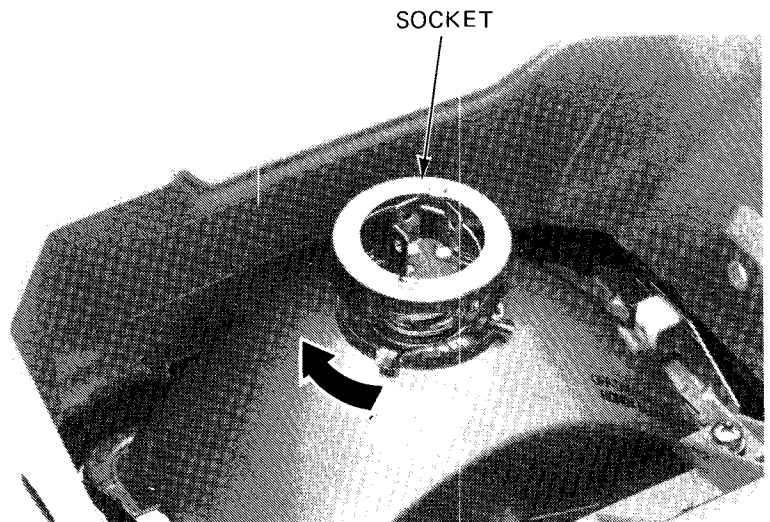

Install the socket holder on the socket with the arrow mark facing up.

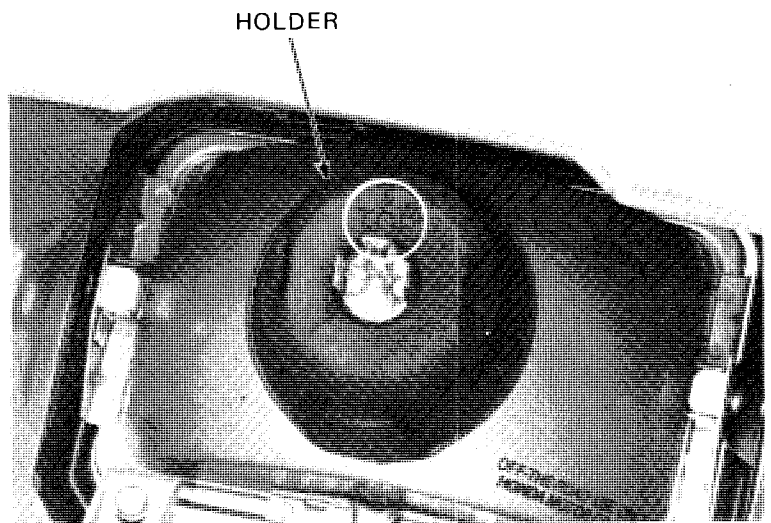

FRONT WHEEL/FRONT FORK/STEERING

Connect the headlight coupler to the headlight bulb terminals.

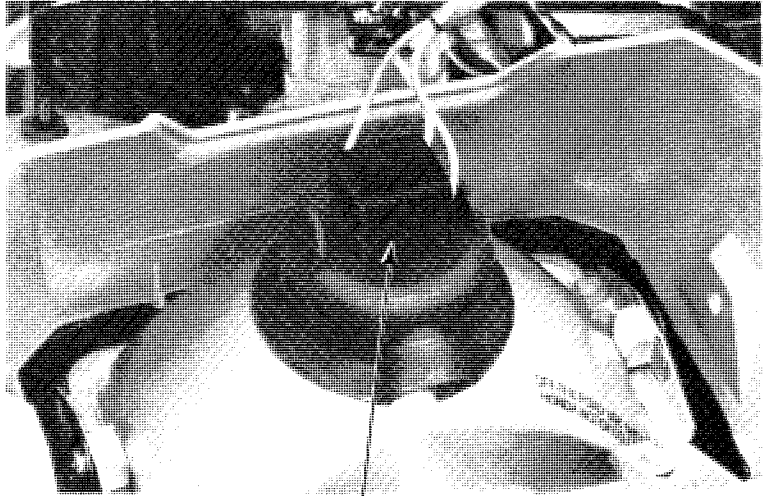

COUPLER

Position the headlight case assembly on the bracket and install it using the two screws and bolt.

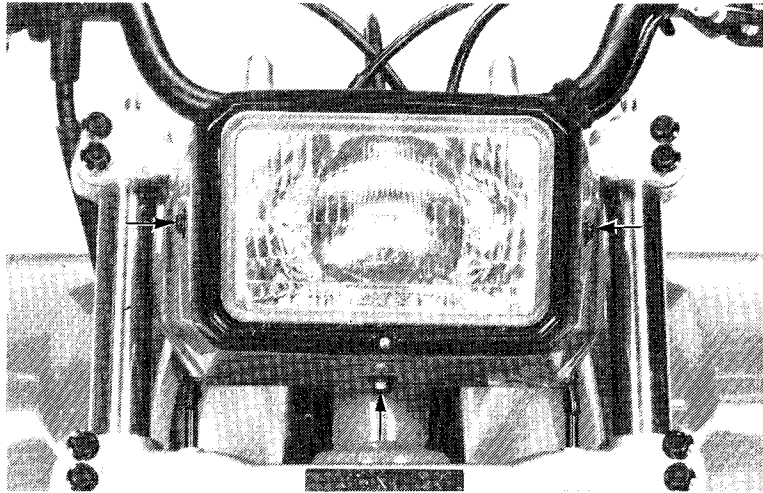

HEADLIGHT BRACKET REMOVAL/ INSTALLATION

Remove the headlight case (page 11-3).
Remove the two bolts attaching the headlight
bracket holders to the fork bridge.
Remove the bracket.

Install the bracket in the reverse order of removal.

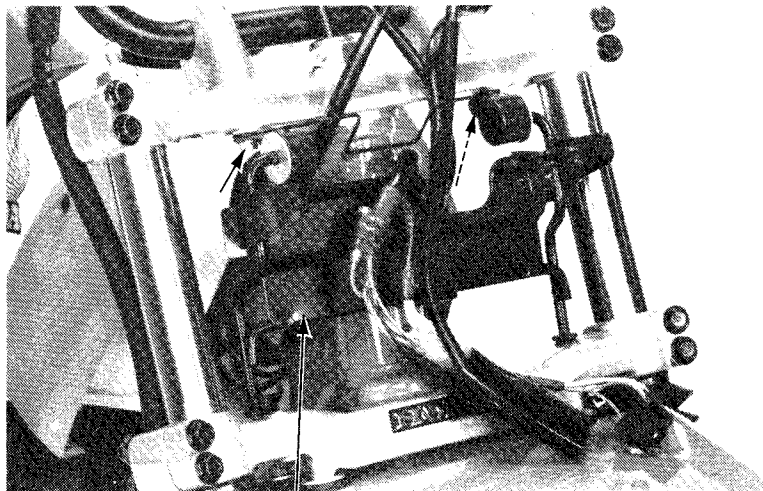

BRACKET

HANDLEBAR

REMOVAL

Remove the two screws and remove the front brake master cylinder and holder.

Remove the two screws and remove the throttle lever housing and holder.

FRONT BRAKE
MASTER CYLINDER

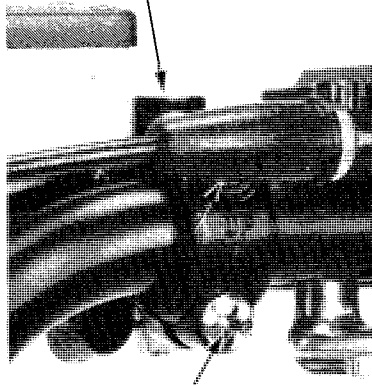

THROTTLE LEVER HOUSING

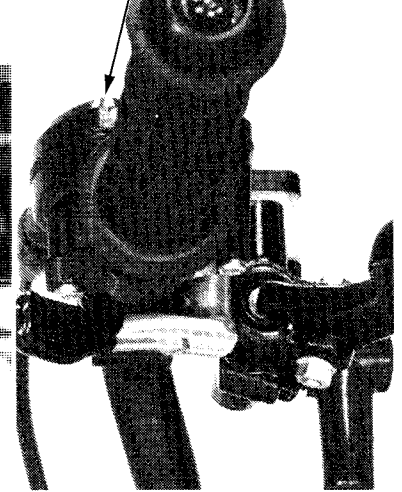

Remove the two screws and remove the clutch/parking brake lever assembly.

Remove the two screws and remove the handlebar switch.

CLUTCH/PARKING BRAKE
LEVER ASSEMBLY

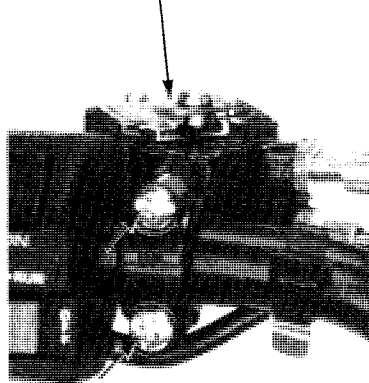

HANDLEBAR SWITCH

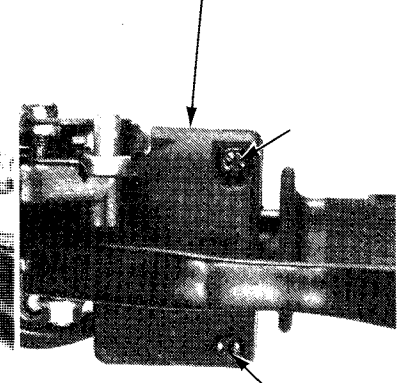

Remove the wire bands.

Remove the handlebar upper holders and handlebar.

WIRE BANDS

UPPER HOLDERS

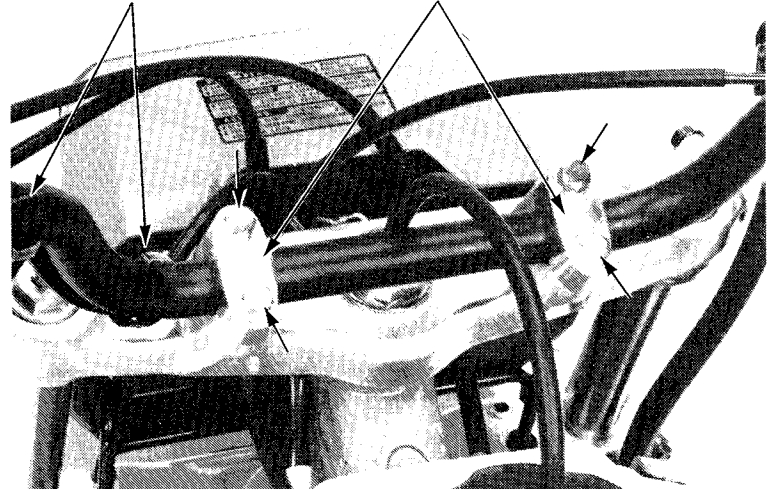

FRONT WHEEL/FRONT FORK/STEERING

INSTALLATION

Place the handlebar onto the lower holders, aligning the punch mark on the handlebar with the top of the lower holder.

Install the handlebar upper holders with the punch marks forward.

Tighten the front bolts first, then tighten the rear bolt.

Attach the handlebar switch wire to the handlebar with the wire bands.

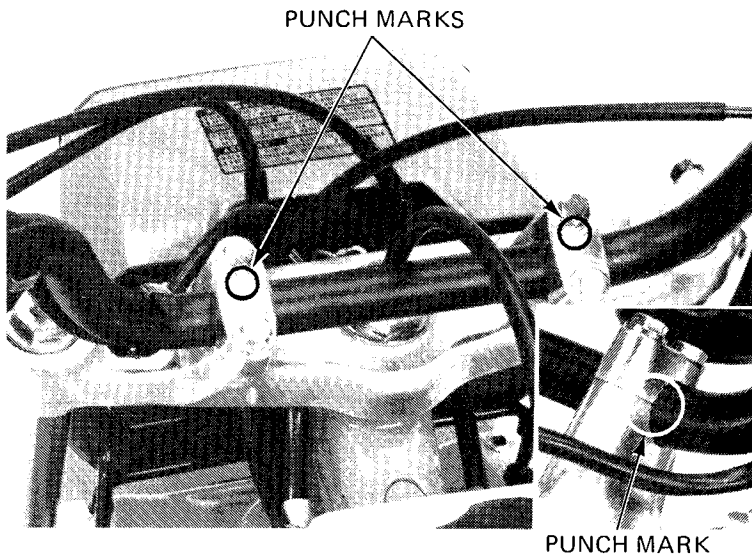

Place the front brake master cylinder on the handlebar and install the holder with the "UP" mark facing up.

Align the master cylinder holder end with the punch mark on the handlebar and tighten the upper screw first, then tighten the lower screw.

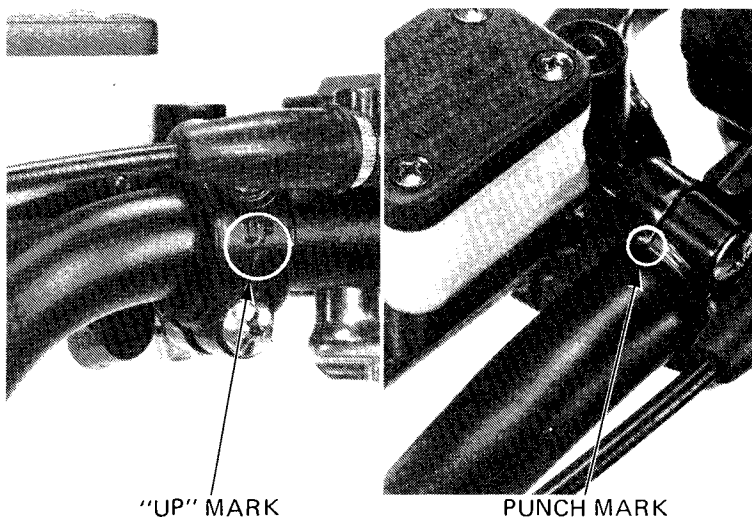

Position the throttle lever housing on the handlebar and install it using the throttle lever housing holder and two screws.

Align the ridge of the housing with the mating surface of the master cylinder and holder, and tighten the forward screw first, then tighten the rear screw.

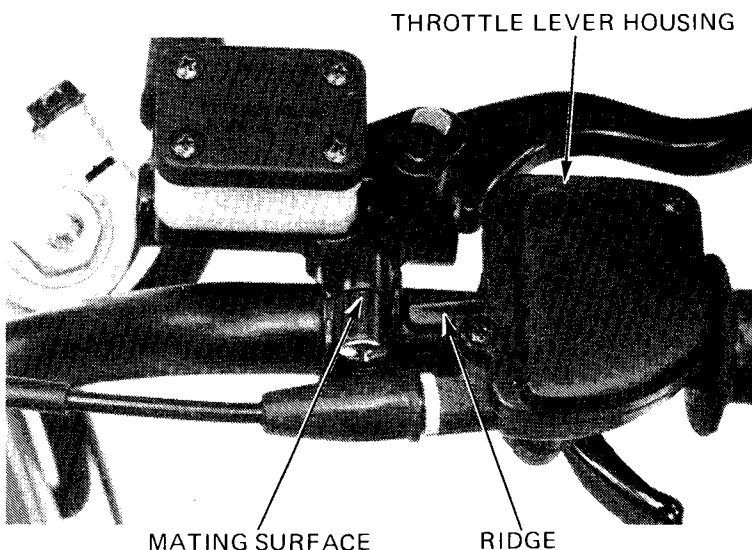

Place the clutch/parking brake lever assembling on the handlebar and install the holder with the "UP" mark facing up.

Align the lever holder end with the punch mark on the handlebar, and tighten the upper screw first, then tighten the lower screw.

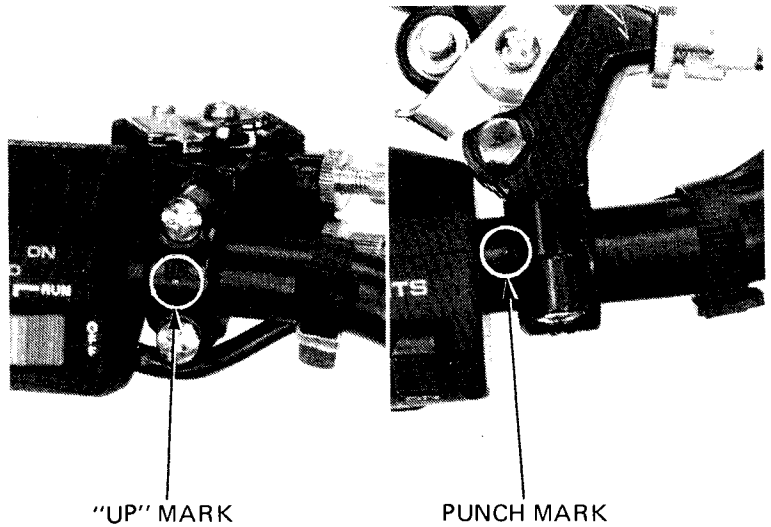

Install the handlebar switch on the handlebar. Tighten the upper screw first, then tighten the lower screw.

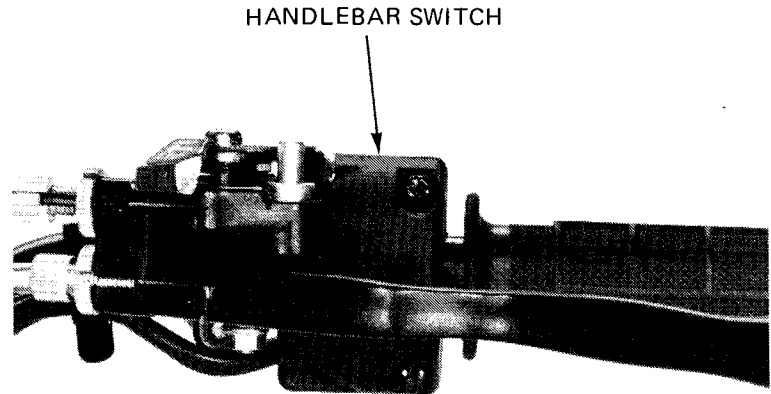

Perform the following inspections after installing the handlebar:

- Cable and wire routing (page 1-7).
- Clutch lever free play (page 3-15).
- Throttle free play and return (page 3-7).
- Operation of parking brake lever (page 3-12).
- Operation of handlebar switch (page 3-17).

FRONT WHEEL/FRONT FORK/STEERING

FRONT WHEEL

FRONT WHEEL REMOVAL

Raise the front wheel off the ground by placing a block or safety stand under the engine.

Remove the wheel nuts.
Loosen the axle holder bolts.

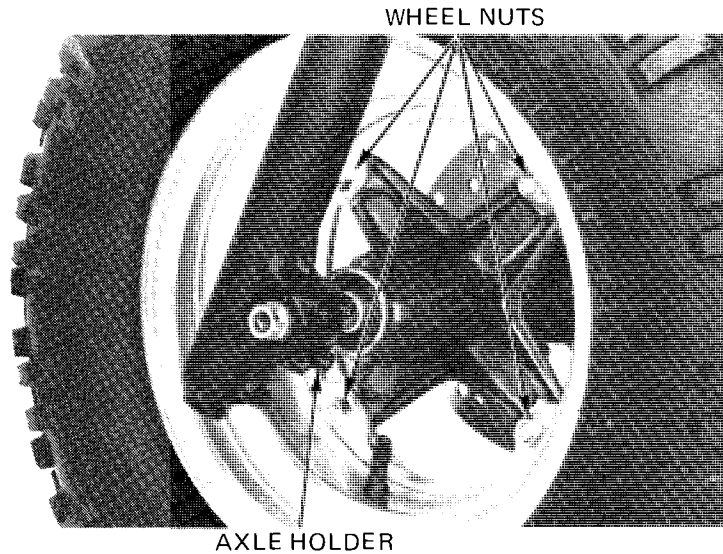

Remove the axle shaft.

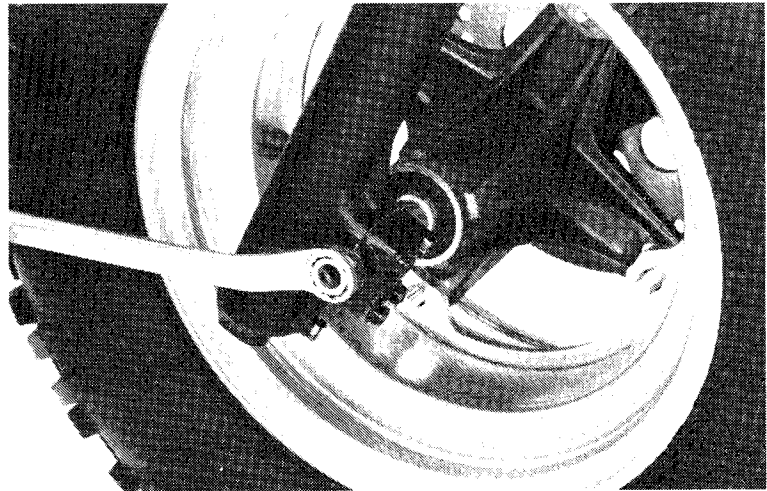

Remove the two caliper bolts and remove the caliper from the right fork leg.

NOTE:

- Place a small wooden wedge between the brake pads to keep them from being forced out at the caliper.
- Do not loosen the brake hose. Whenever the brake hose is loosened, it is necessary to bleed air from the brake. Refer to page 14-3 for bleeding procedures.

Remove the front wheel and hub.

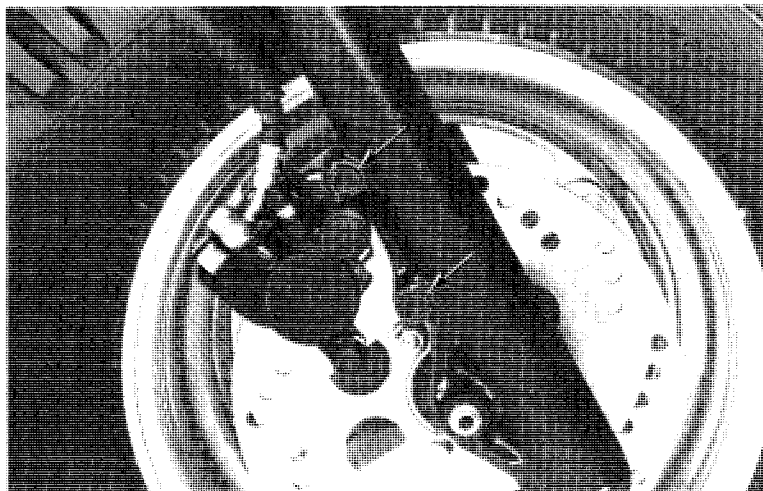

FRONT AXLE INSPECTION

Set the axle in V-blocks and measure the shaft runout.

SERVICE LIMIT: 0.5 mm (0.02 in)

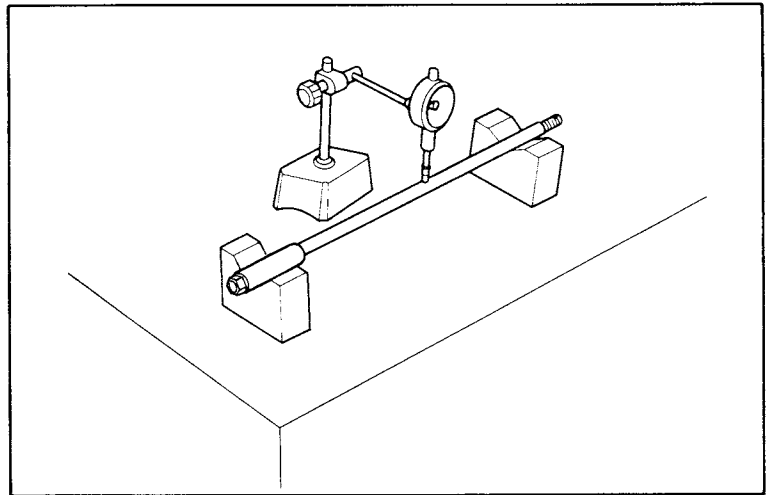

WHEEL BEARING INSPECTION

Check the wheel bearings by placing the wheel hub in a trueing stand and spinning the hub by hand.

Replace the bearings if they are noisy or have excessive play.

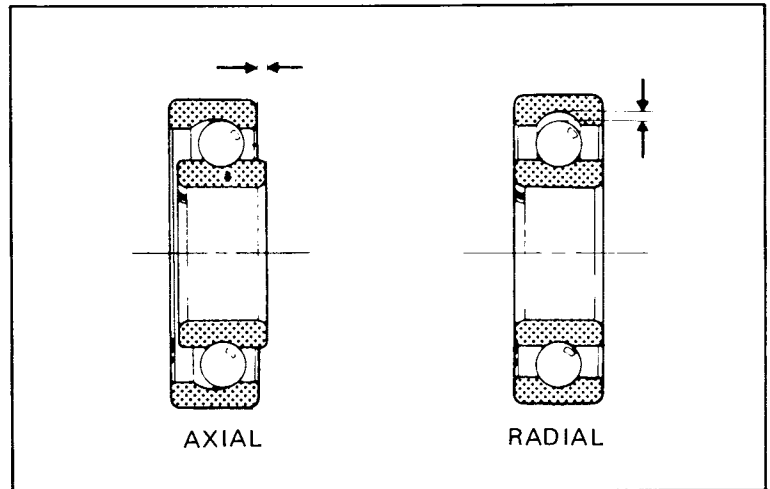

Remove the dust seals.
Drive the wheel bearings out and remove the center collar.

NOTE:

Once bearings have been removed from the hub, they should be replaced with new ones.

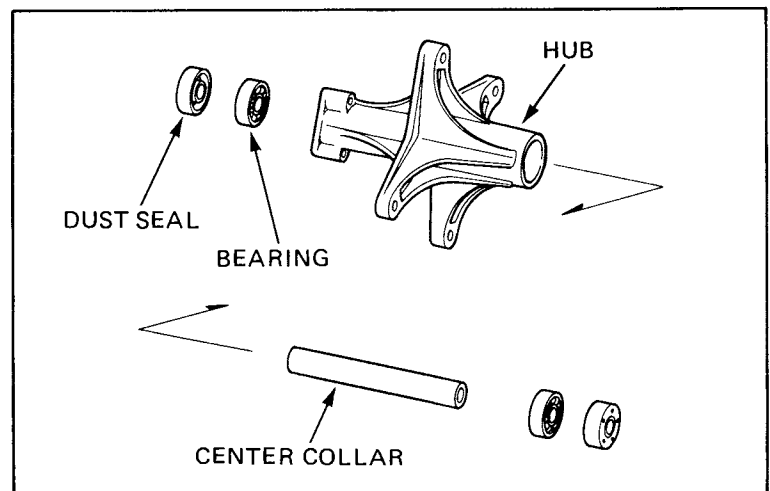

FRONT WHEEL/FRONT FORK/STEERING

TIRE REMOVAL (U.S.A. only)

NOTE:

This service requires the Universal Bead Breaker (GN—AH—958—BB1) available in U.S.A. only.

Remove the core from the valve stem.

CAUTION:

- Use of the *Bead Breaker* tool is required for tire removal.
- Do not damage the bead seating area of the rim.
- Use a *Coats 220 Tire Changer* or equivalent to remove the tire from the rim. If a tire changer is not available, rim protectors and tire irons may be used.

Install the proper size blade onto the breaker arm assembly.

Short blade — 7"/8" rims.

Long blade — 9"/11" rims.

CAUTION:

Use of an improper size blade may result in damage to the rim, tire or blade.

Place the proper size adapter onto the threaded shaft and then put the wheel over the threaded shaft and adapter.

Lube the bead area with rubber lubricant, pressing down on the tire sidewall/bead area in several places, to allow the lubricant to run into and around the bead. Also lube the area where the breaker arm will contact the sidewall of the tire.

While holding the breaker arm assembly at an approximate 45° position, insert the blade of the breaker arm between the tire and rim. Push the breaker arm inward and downward until it is in the horizontal position with its press block in contact with the rim.

NOTE:

It may be necessary to tap the breaker arm with a brass hammer to install it the last 3 mm. While doing so, be sure to hold the arm down in the horizontal position.

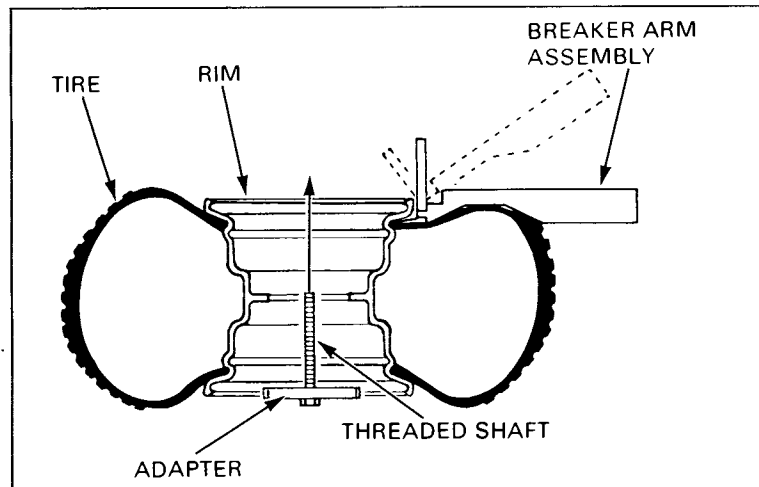
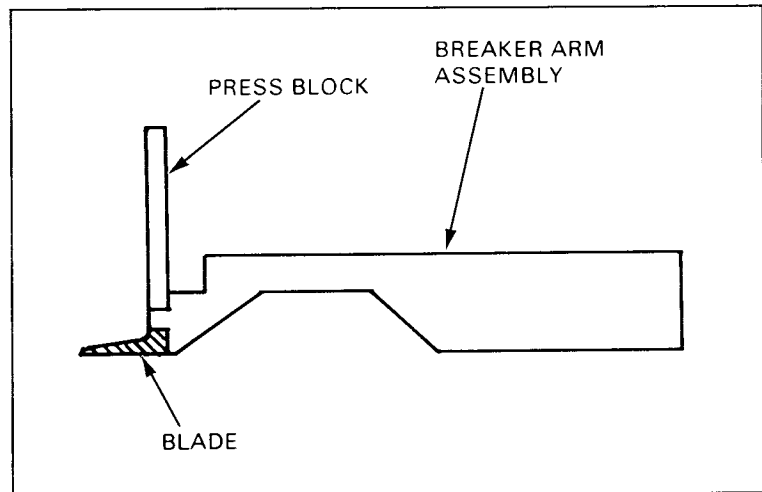

With the breaker arm in the horizontal position, place the breaker press head assembly over the breaker arm press block. Make sure the press head bolt is backed out all the way and then position the nylon buttons on the press head against the inside edge of the rim.

Insert the threaded shaft through the appropriate hole in the breaker press head assembly and then tighten the lever nut until both ends of the breaker press head assembly are in firm contact with the rim.

NOTE:

Insert bolts through the holes in the rim hub mounting tabs and the adapter to position the adapter properly.

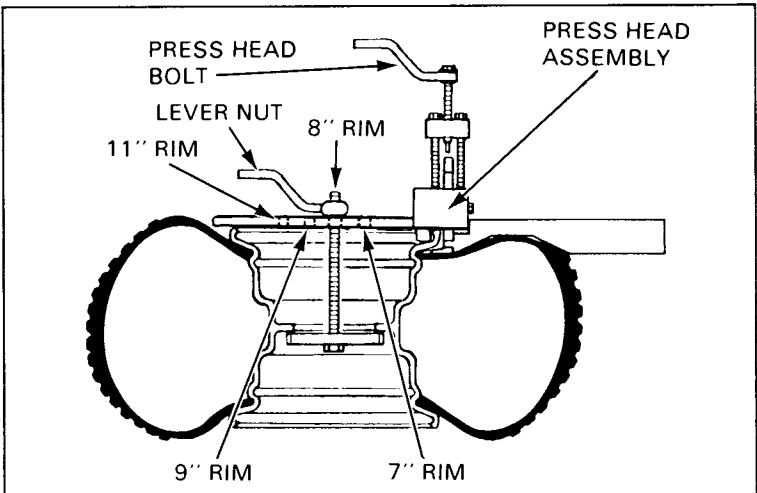

Tighten the press head bolt until the reference mark on the press block is aligned with the top edge of the press head.

If the rest of the bead cannot be pushed down into the center of the rim by hand, loosen the press head bolt and the lever nut. Rotate the breaker arm assembly and breaker press head assembly 1/8 to 1/4 the circumference of the rim. Tighten the lever nut and then tighten the press head bolt as described. Repeat this procedure as necessary until the remainder of the bead can be pushed down into the center of the rim.

Assemble the Universal Bead Breaker on the other side of the wheel and break the bead following the same procedures.

Remove the tire from the rim using a tire changer machine or tire irons and rim protectors.

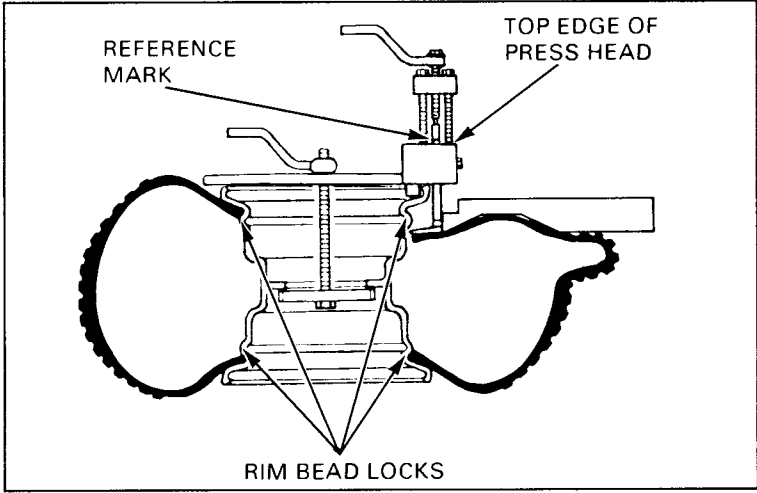

FRONT WHEEL/FRONT FORK/STEERING

TIRE REMOVAL (Not available in U.S.A.)

NOTE:

This service requires the Tire Bead Breaker (07772-0040000) not available in U.S.A.

CAUTION:

- Do not apply water, soap water, oil etc. to the tire, rim and tool when removing the tire. The tool breaker arm may slip off the tire and the bead can not be broken off the tire.
- Do not damage the bead seating area of the rim.
- Follow the breaker manufacturer's instructions.

Insert the narrow end (A side) of the breaker arm between the tire and the rim.

Position the breaker arm compressor onto the rim center as shown.

Keep the breaker arm horizontal and align the end of the compressor bolt with the arm hole.

Screw in the breaker arm compressor bolt to break the bead from the tire.

If the rest of the head cannot be pushed down into the center of the rim, remove and reposition the compressor and arm $1/8$ to $1/4$ the circumference of the rim. Tighten the compressor bolt to break the bead. Repeat this procedure as necessary until the remainder of the bead can be pushed down into the center of the rim.

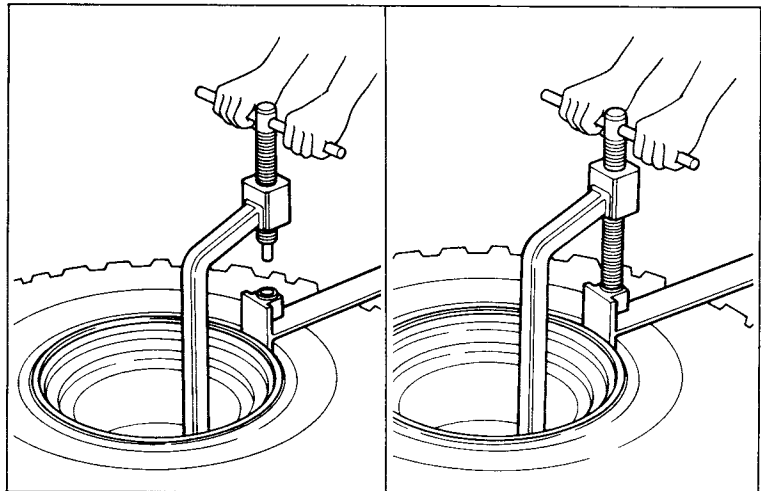
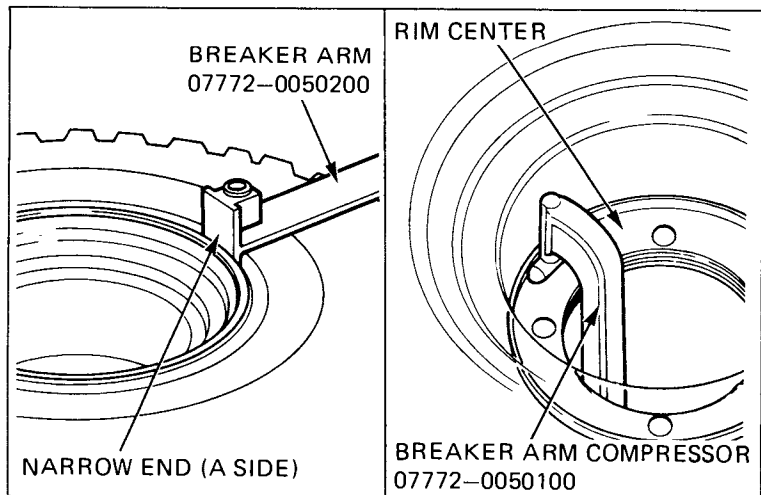

If the bead breaking is difficult with the narrow end (A side) of the breaker arm, use the wide end (B side) of the arm and repeat the procedure above.

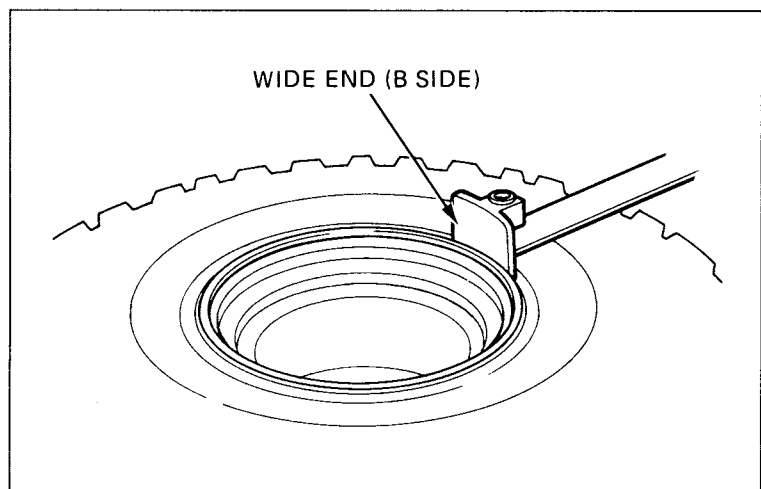

TIRE REPAIR

NOTE:

Use the manufacturer's instructions for the tire repair kit you are using. If your kit does not have instructions, the procedures provided here.

Check the tire for puncturing objects. Chalk mark the punctured area and remove the puncturing object.

Inspect and measure the injury. Tire repairs for injuries larger than 15 mm (5/8 in) should be a section repair. Section repairs should be done by a professional tire repair shop.

If the injury is smaller than 15 mm (5/8 in), proceed with the repair as described here.

Install a rubber plug into the injury as follows:

Apply cement to a plug inserting needle and work the needle into the injury to clean and lubricate it. Do this three times. Do not let the cement dry.

Insert and center a rubber plug through the eye of the inserting needle.

Apply cement to the rubber plug.

Push the inserting needle with plug into the injury until the plug is slightly above the tire. Twist the needle and remove it from the tire, the plug will stay in the tire.

NOTE:

Be careful not to push the plug all the way into the tire to prevent it from falling into the tire.

Trim the plug to 6 mm (1/4 in) above the tire surface.

Repeat the above procedure if the puncture is large. Do not use more than two plugs per injury.

Allow the repair to dry. Drying time will vary with air temperature. Refer to the tire repair kit manufacturer's recommendations.

Inflate the tire and test the seal by dabbing a small amount of cement around the plug. Escaping air will cause a bubble in the cement. If there is leakage, remove the tire (Page 11-13) and apply a cold patch to the inside of the tire as described.

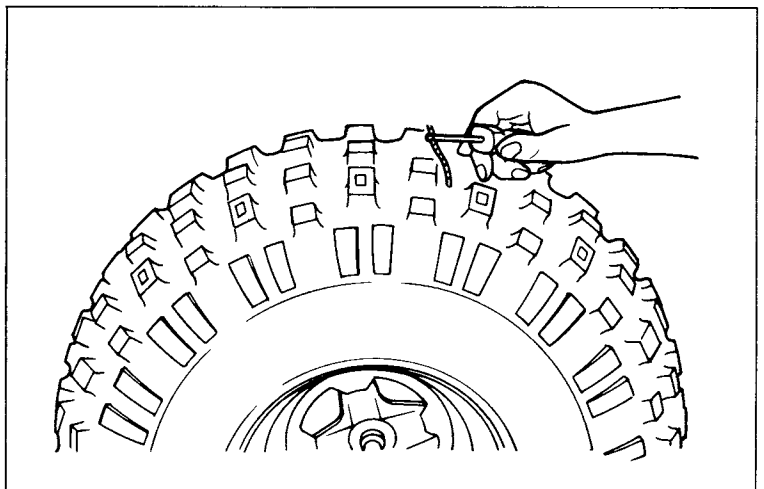
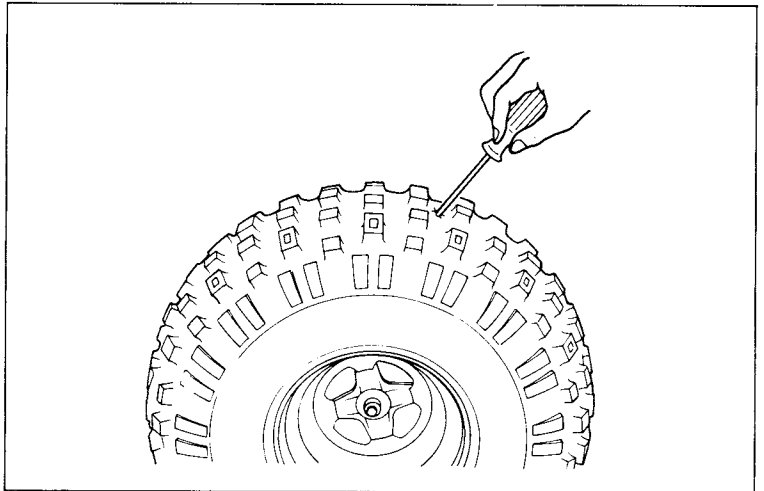
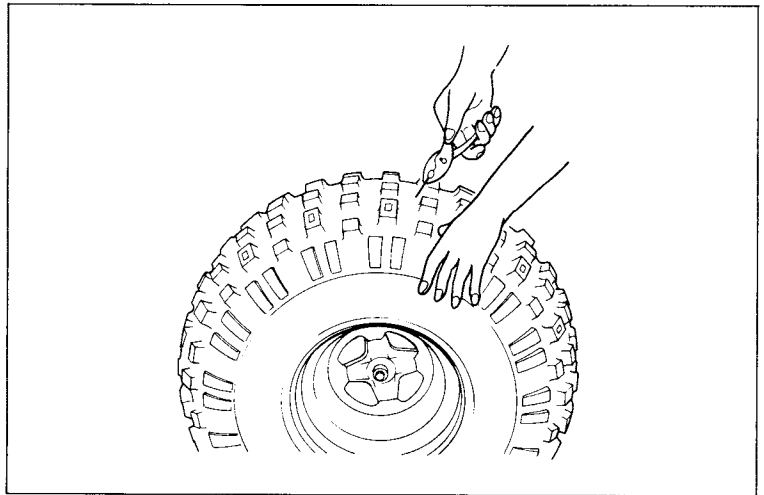

FRONT WHEEL/FRONT FORK/STEERING

If a plug has been inserted, trim it even with the inner tire surface.

Temporarily place a rubber patch that is at least twice the size of the puncture over the injury. Make a mark around the patch, slightly larger than the patch itself. Remove the patch.

Roughen the area marked inside the tire with a tire buffer or a wire brush. Clean the rubber dust from the buffed area.

Apply cement over the area marked and allow it to dry. Remove the lining from the patch and center it over the injury. Press the patch against the injury using the # special roller.

NOTE:

- Allow cement to dry until tacky before applying patch.
- Do not touch the cement with dirty or greasy hands.

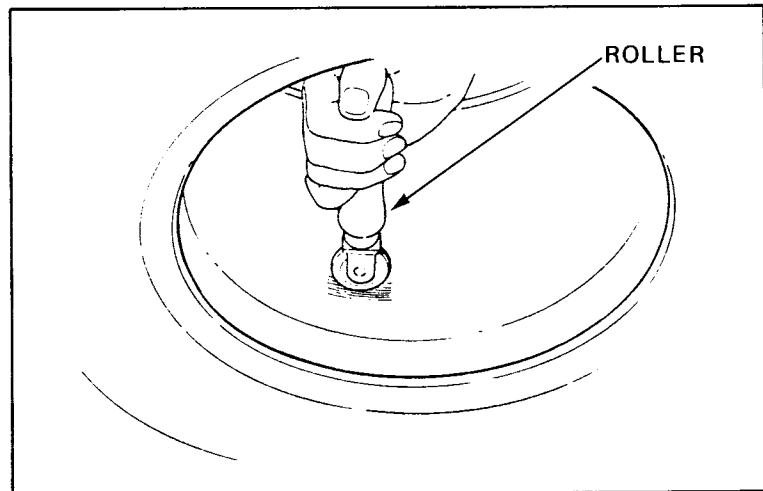
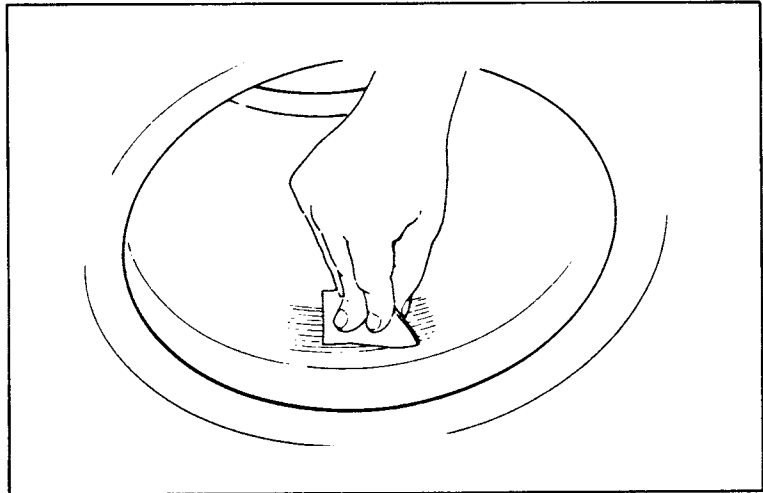

TIRE ASSEMBLY

Clean the rim bead seat and flanges.

Install the tire on the rim.

Apply a coat of clean water to the rim flanges, bead seat and tire bead.

CAUTION:

Never use lubricant of silicone.

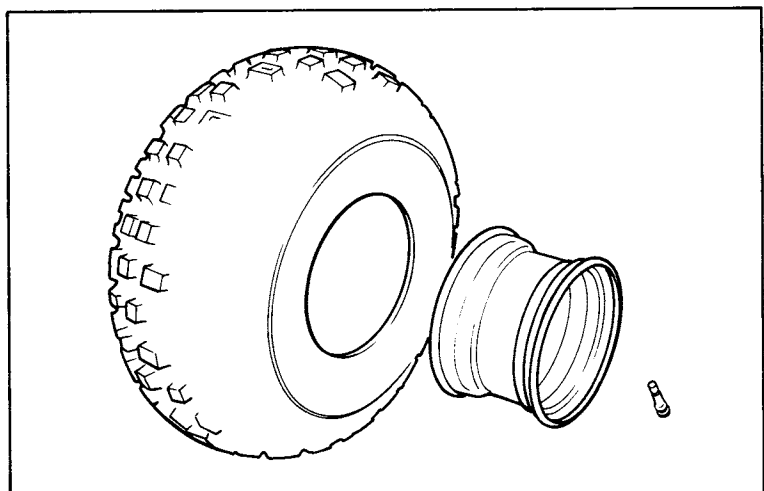

Inflate the tire to seat the tire bead.

CAUTION:

Be careful not to inflate the tire with more than 1.2 kg/cm² (17 psi) of air.

If the tire does not fit to the rim with 1.2 kg/cm² (17 psi) of air pressure, release the air from the tire and apply a coat of soapy water to the tire bead and bead seating surface of the rim. Then, inflate the tire with air again.

Deflate the tire. Wait 1 hour and inflate the tire to the specified pressure.

	Recommended pressure	Min. pressure	Max. pressure	Standard tire circumference
Front	3.3 psi (23 kPa, 0.23kg/cm ²)	2.8 psi (20 kPa, 0.2kg/cm ²)	3.7 psi (26 kPa, 0.26kg/cm ²)	1,895 mm (74.6 in)
Rear	2.4 psi (17 kPa, 0.17kg/cm ²)	2.0 psi (14 kPa, 0.14kg/cm ²)	2.8 psi (20 kPa, 0.2kg/cm ²)	1,745 mm (68.7 in)

NOTE:

The rear tires must have the same circumference to prevent improper steering and handling.

Check for air leaks and install the valve cap.

FRONT WHEEL ASSEMBLY

Pack all front wheel bearing cavities with wheel bearing grease.

Drive in the left bearing.

DRIVER 07749-0010000
ATTACHMENT, 42 x 47 mm 07746-0010300
PILOT, 15 mm 07746-0040300

Install the collar and drive in the right bearing.

NOTE:

Do not allow the bearings to tilt while driving them in.

Apply grease to the inside of each dust seal.
 Install the dust seals and distance collars.

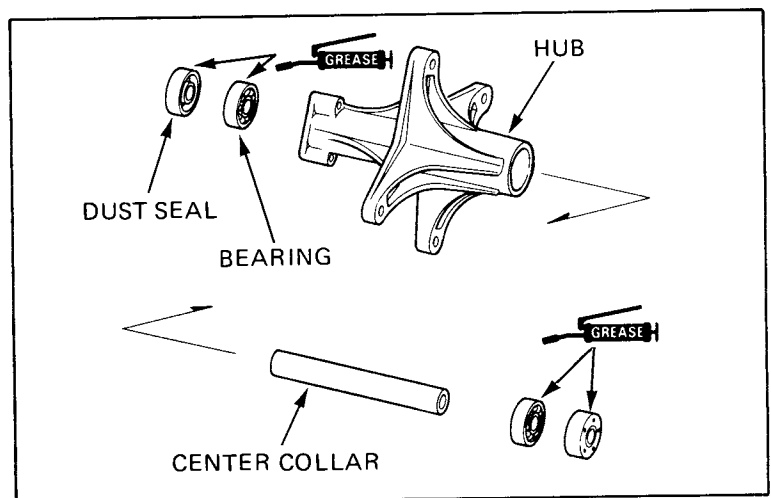

FRONT WHEEL/FRONT FORK/STEERING

FRONT WHEEL INSTALLATION

Install the front wheel and hub.

Position the caliper on the disc and then install the caliper on the right fork leg using the two bolt.
Install the axle shaft.

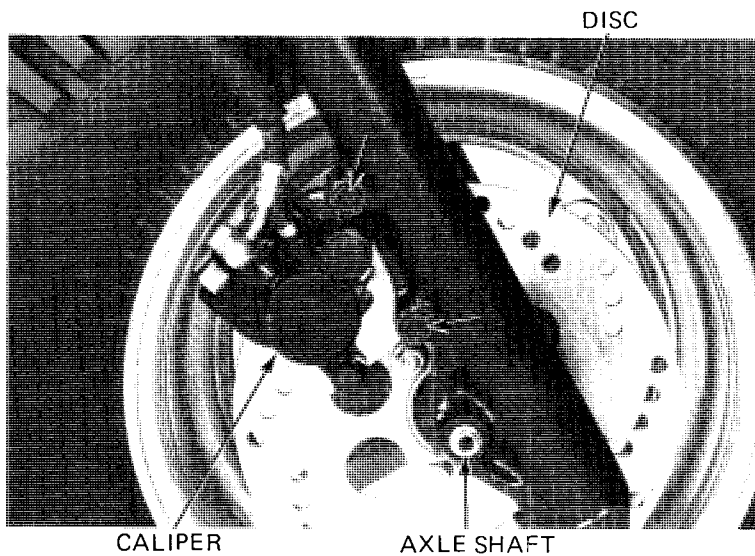

Install the front wheel on the hub studs and tighten the wheel nuts.

Tighten the axle nut.

TORQUE: 70–110 N·m (7.0–11.0 kg·m, 51–80 ft·lb)

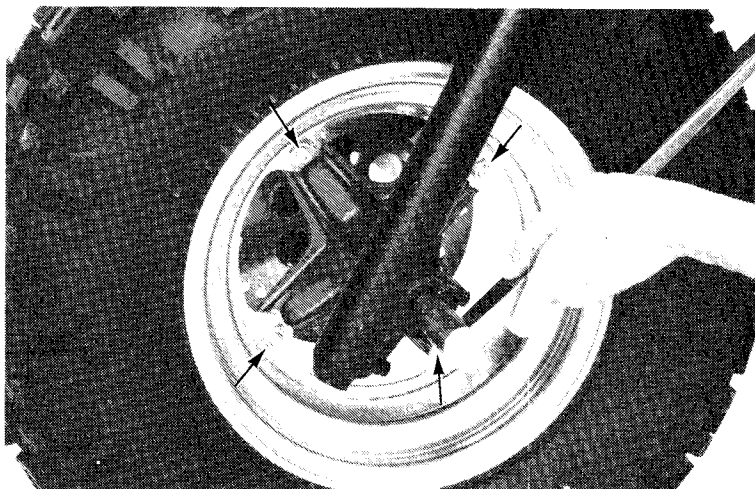

Tighten the axle holder bolts.

TORQUE: 10–14 N·m (1.0–1.4 kg·m, 7–10 ft·lb)

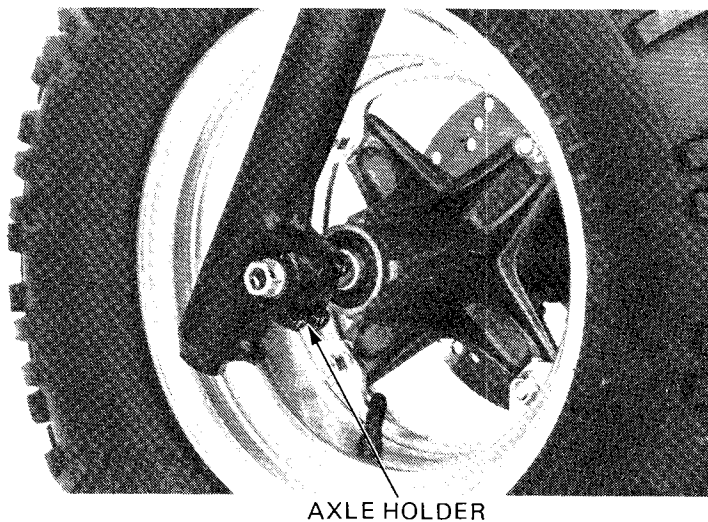

FRONT FORK

REMOVAL

Remove the front wheel (page 11-10).

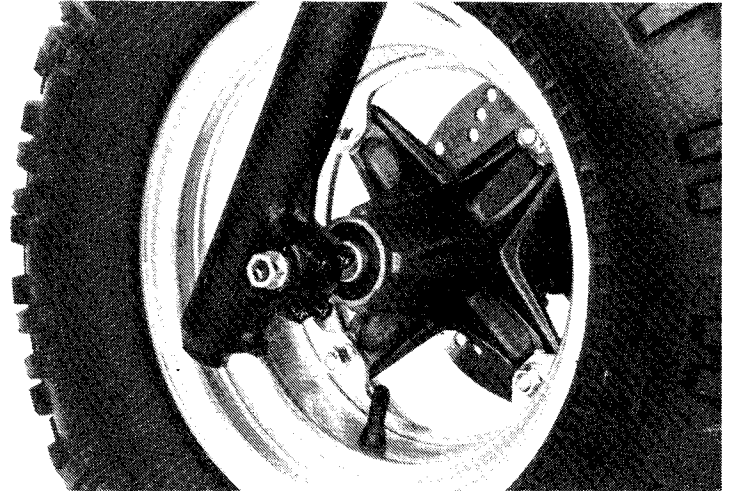

Loosen the fork boot clamp.

FORK BOOT CLAMP

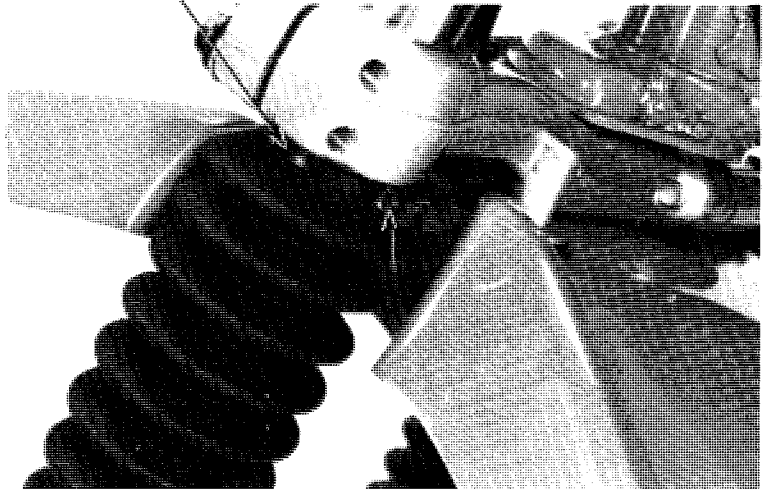

Press on the air valves to depressurize the forks. Remove the front forks and then slide the fork boot off the fork tube.

AIR VALVE

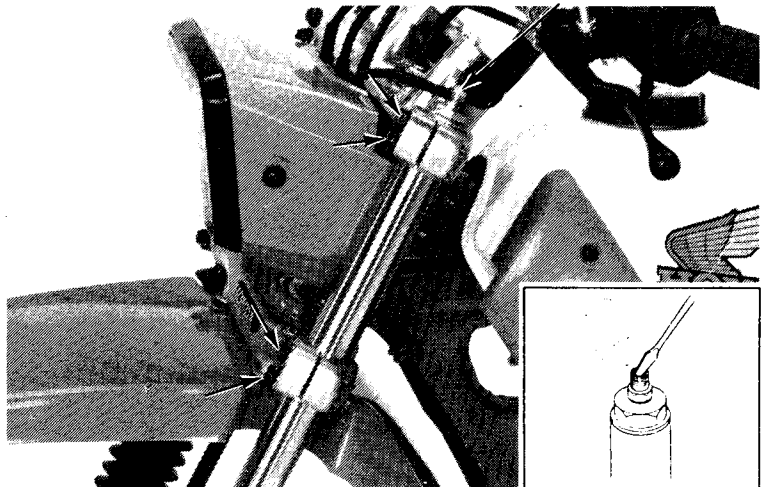

FRONT WHEEL/FRONT FORK/STEERING

Hold the fork tube in a vise with soft jaws or a shop towel. Avoid the sliding surface. Remove the fork cap bolt.

WARNING

The fork cap is under spring pressure. Use care when removing the cap to keep it from causing injury.

Remove the fork springs.

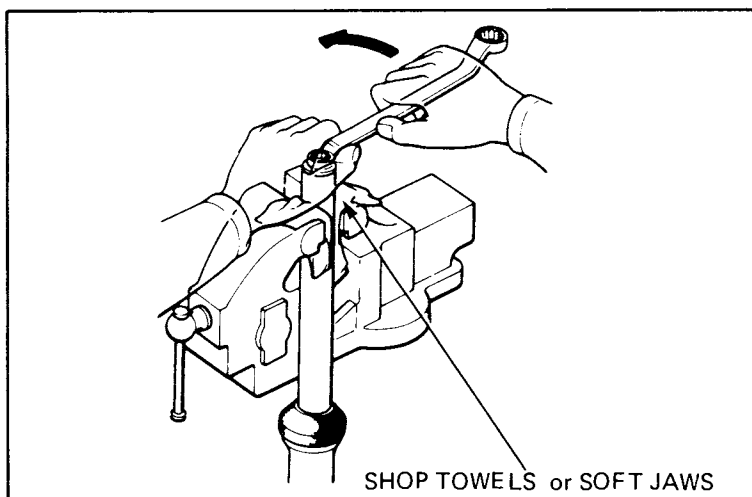

Turn the fork tube upside down and pump it to help drain the fork fluid.

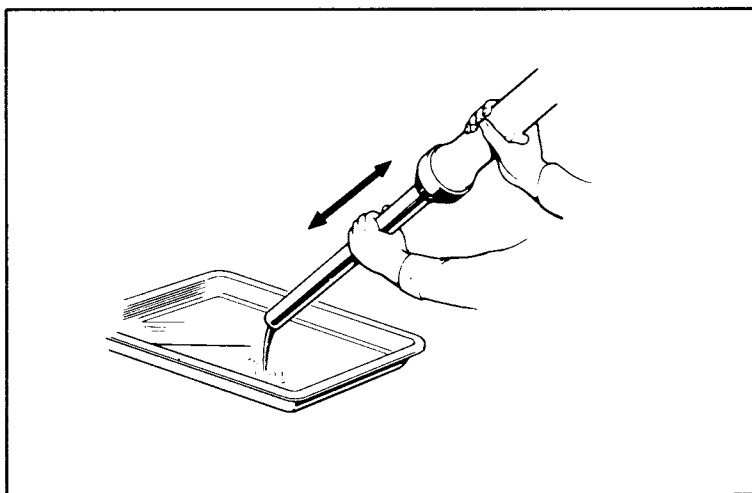

Hold the fork slider in a vise with soft jaws or a shop towel. Remove the hex bolt.

CAUTION:

Do not overtighten the slider in the vise. Overtightening will damage the slider.

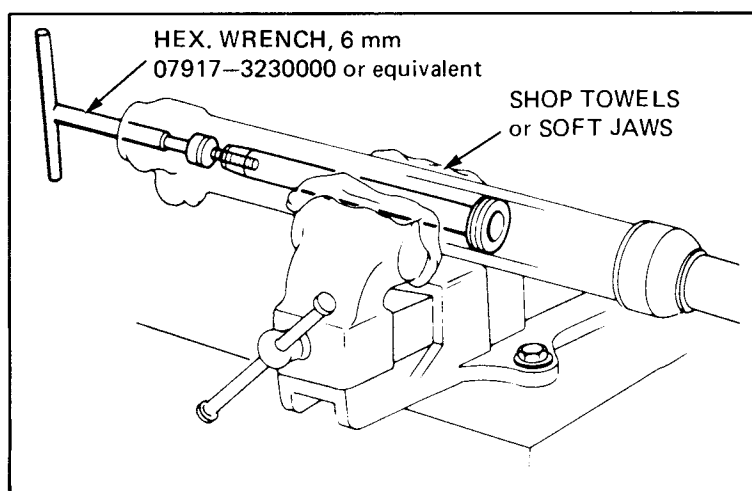

FORK SPRING INSPECTION

Measure the free length of the fork springs.
Replace the springs if they are shorter than the service limit.

SERVICE LIMIT:

- Spring A: 145 mm (5.7 in)**
- Spring B: 390 mm (15.4 in)**

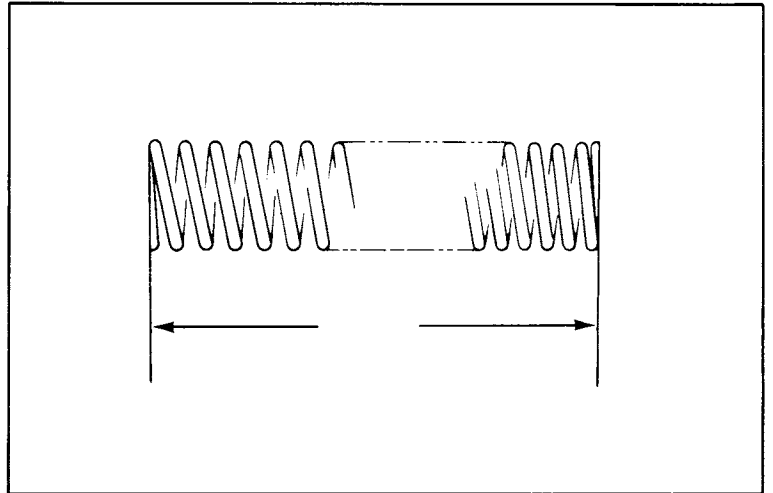

Remove the dust seal.

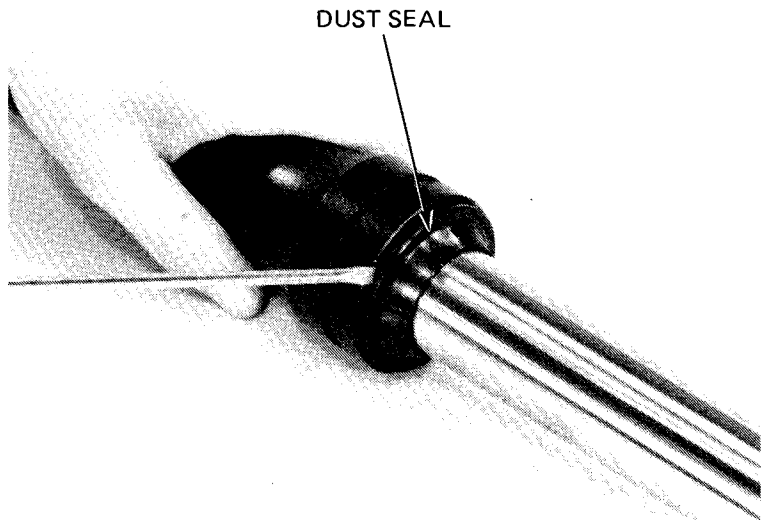

Remove the snap ring with snap ring pliers.
Remove the back-up ring.
Remove the fork tube from the slider with several quick strokes, back and forth. The slider bushing causes resistance and the fork tube bushing must force it out.

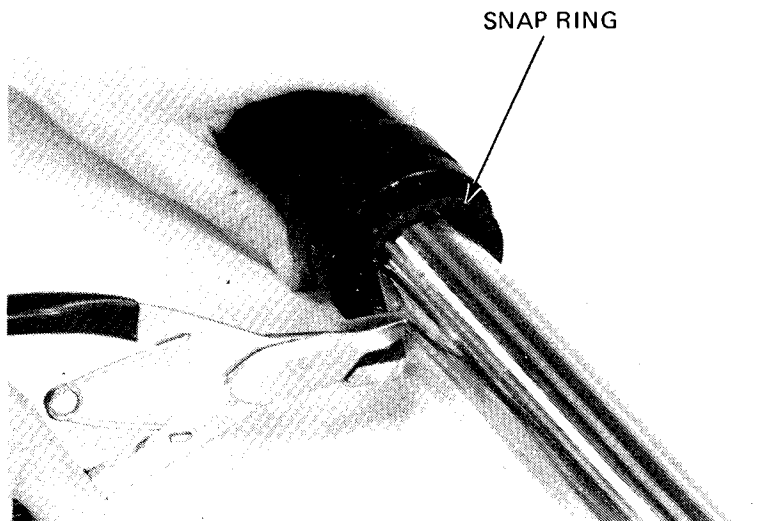

FRONT WHEEL/FRONT FORK/STEERING

Remove the oil seal, back-up ring and slider bushing from the fork tube.

NOTE:

Do not remove the fork tube bushing unless it is necessary to replace it with a new one. See installation (page 11-22).

Remove the oil lock piece from the slider
Remove the fork piston from the fork tube.

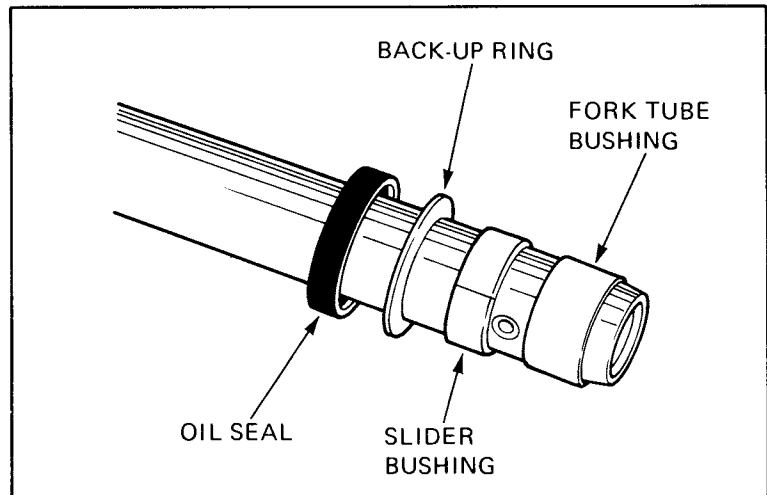

FORK TUBE, PISTON AND FORK SLIDER INSPECTION

Check the fork tube, piston and slider for score marks, scratches or abnormal wear.
Replace any components which are worn or damaged.

Check the fork piston ring for wear or damage.
Check the rebound spring for fatigue or damage.

Place the fork tube in V blocks and read the runout.

Take 1/2 of the total indicator reading to determine the actual wear.

SERVICE LIMIT: 0.20 mm (0.008 in)

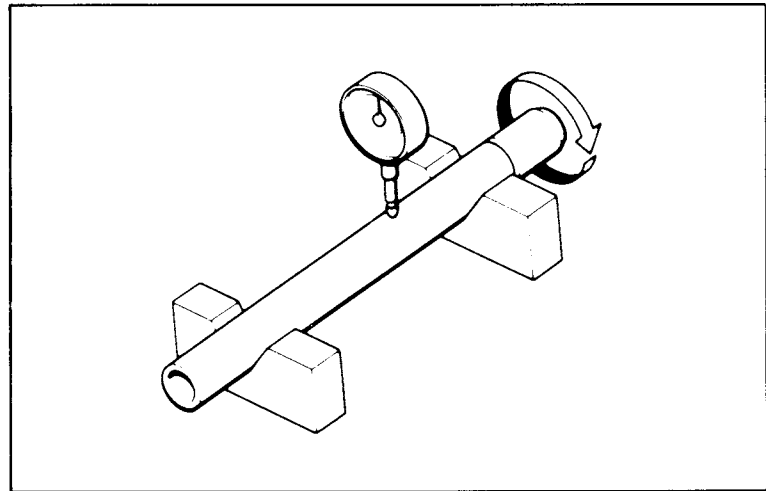

BUSHING/BACK-UP RING INSPECTION

Visually inspect the slider and fork tube bushing.
Replace the bushing if there is excessive scoring or scratching, or if the teflon is worn so that the copper surface appears on more than 3/4 of the entire surface.

Check the back-up ring at the points shown.
Replace if there is any distortion at the points shown.

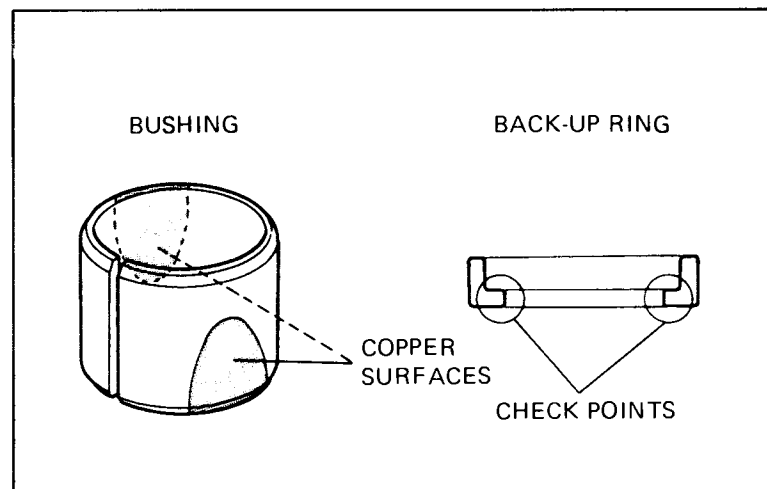

ASSEMBLY

NOTE:

Wash all removed parts in solvent and wipe them off thoroughly before assembly.

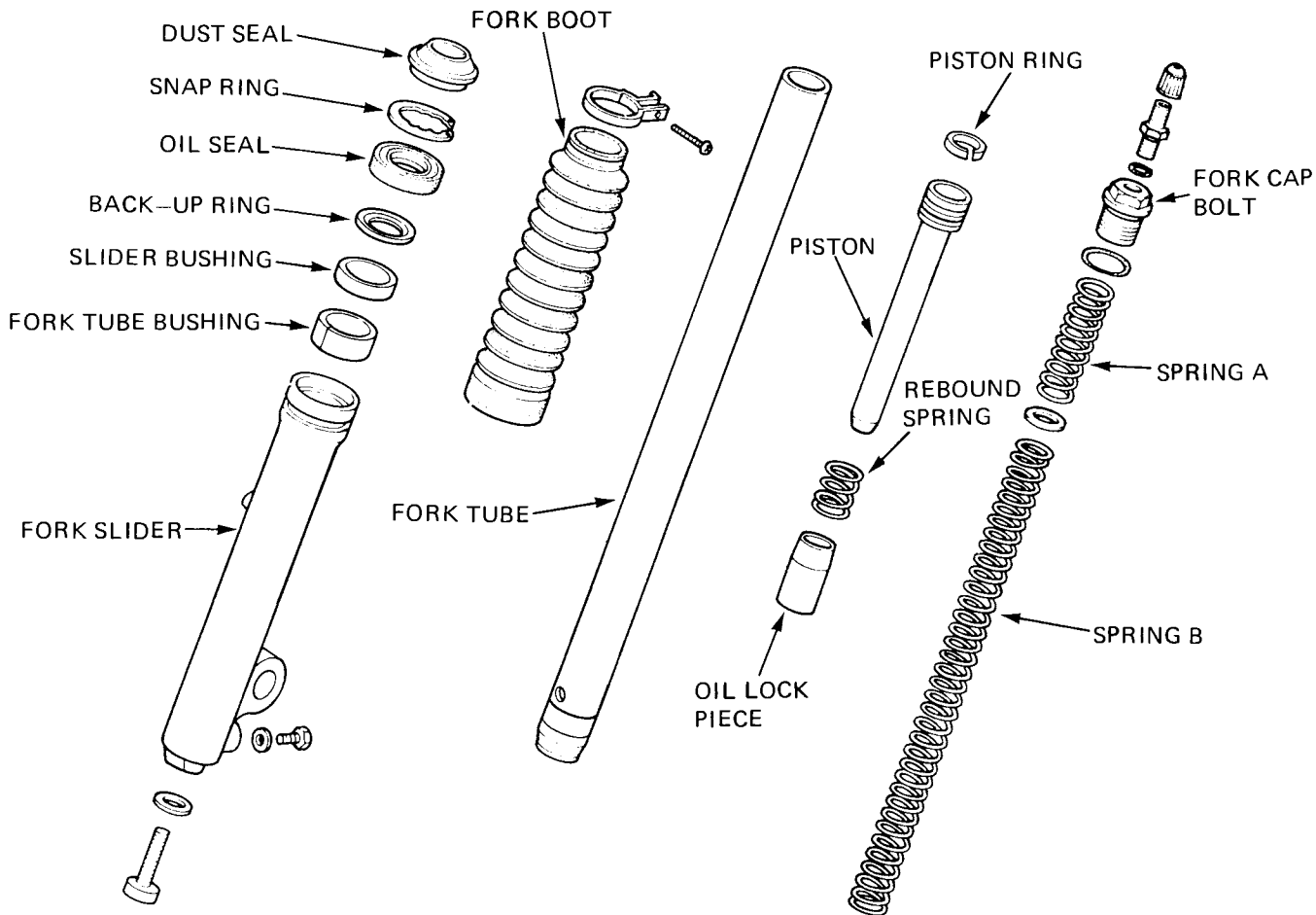

Install the piston ring on the piston.

Install the fork tube bushing if a new one is being installed.

NOTE:

Make sure the oil seal and back-up ring are correctly positioned before installation.

Place the rebound spring and piston into the fork tube. Place the oil lock piece on the end of the piston and insert the fork tube into the slider.

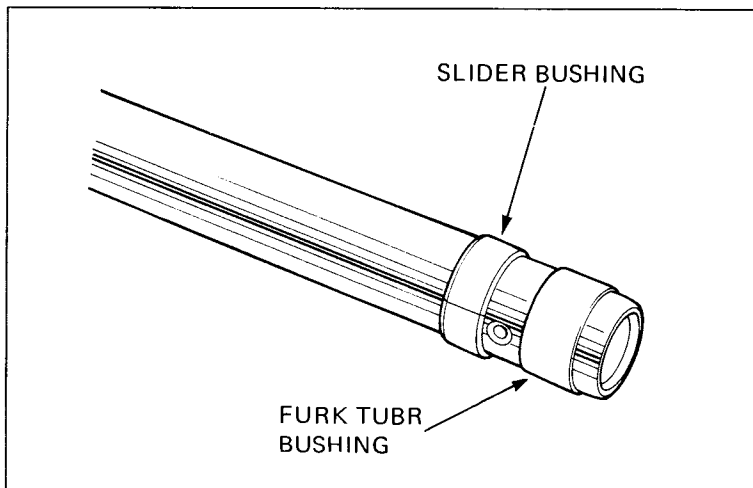

FRONT WHEEL/FRONT FORK/STEERING

Clean the hex bolt threads and apply a locking agent to the threads.

NOTE:

- To tighten the hex bolt, it may be necessary to install the fork springs and tighten the fork cap temporarily.
- Take care not to distort the slider in the vise.

TORQUE: 15–25 N·m (1.5–2.5 kg·m, 11–18 ft·lb)

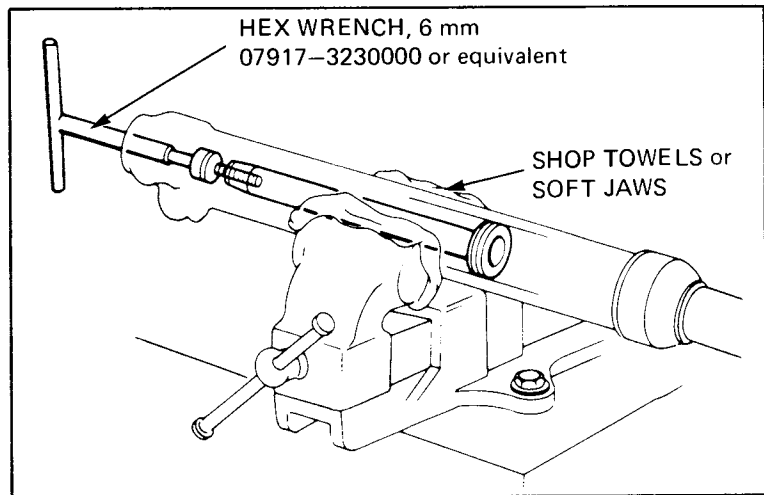

Install the oil seal into the top of the slider. Apply ATF to the oil seal and drive it in with the fork seal driver.

NOTE:

Use the old oil seal with fork seal driver attachment to install the new oil seal.

The fork seal is seated when the groove in the slider is seen at top of the seal.

Install the snap ring and dust seal.

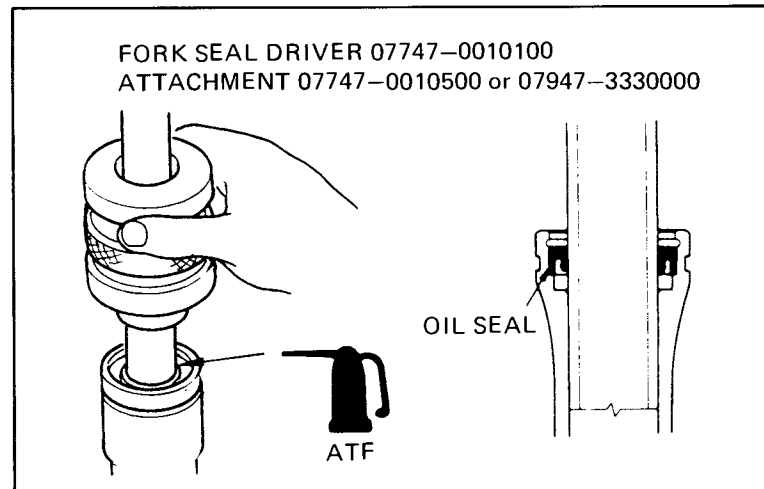

Fill the forks with the specified amount of ATF.

SPECIFIED FLUID: ATF or equivalent
CAPACITY:

1983	206.5–211.5 cc (6.98–7.15 ozs)
After 1983	211.5–216.5 cc (7.15–7.31 ozs)

NOTE:

- Do not overfill. Overfilling causes improper suspension performance.
- Fill both forks with equal amounts of ATF.

Install the fork springs.

Compress the front fork and measure the oil level from the top of the tube.

OIL LEVER: 198 mm (7.8 in)

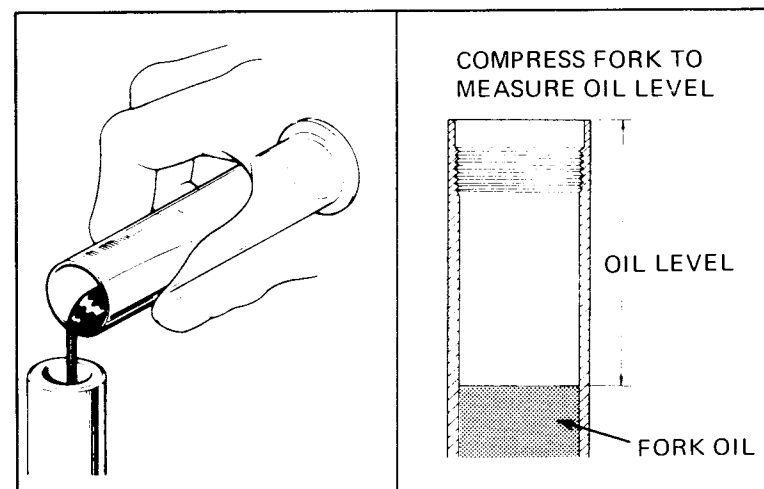

Tighten the fork caps:

TORQUE: 15–35 N·m (1.5–3.5 kg·m, 11–25 ft·lb)

CAUTION:

Use shop towels or soft jaws to avoid damaging the fork tube.

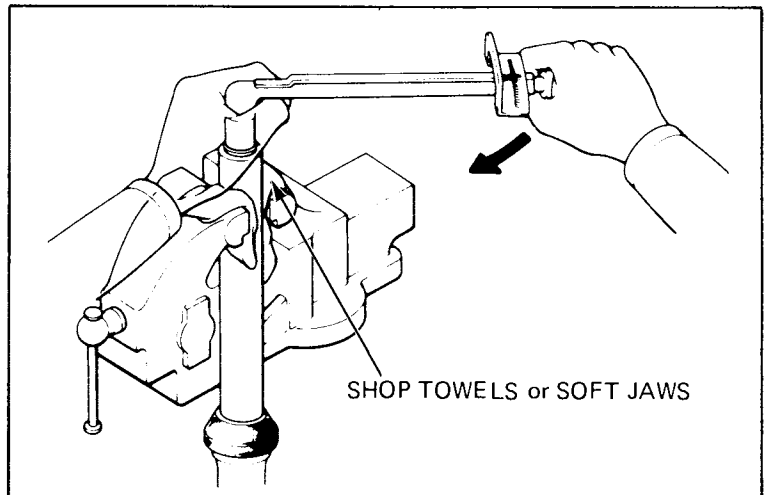

Install the fork boot and boot clamp.

NOTE:

Do not tighten the clamps until the forks are properly installed on the vehicle.

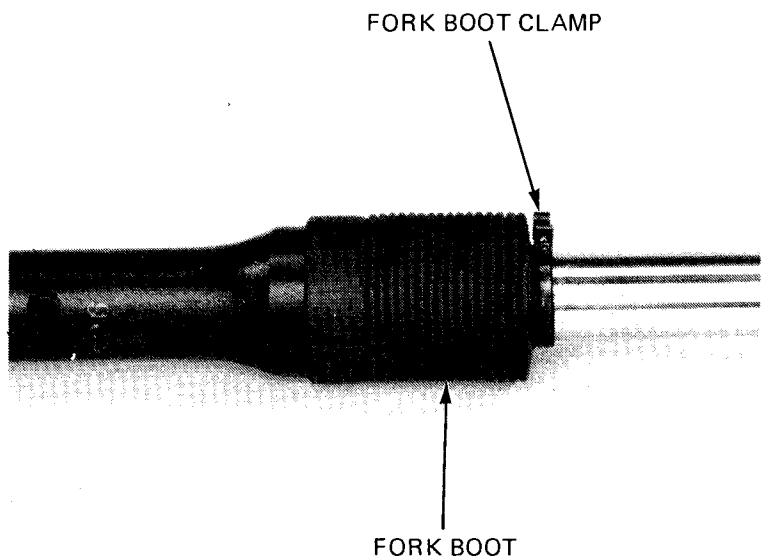

INSTALLATION

Install the front forks into the fork bridge and steering stem while rotating them. Be sure that the top of each tube is flush with the top of the fork bridge.

Tighten the fork tube pinch bolts.

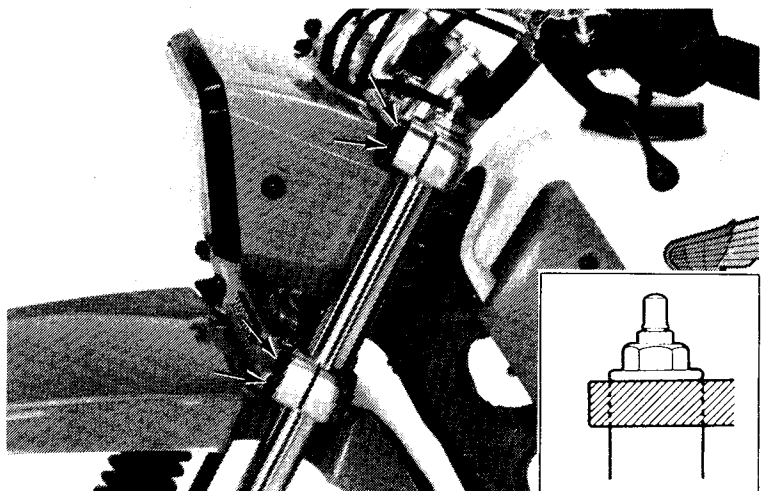

FRONT WHEEL/FRONT FORK/STEERING

Slide the fork boot up to the bottom bridge and tighten the fork boot clamp.

FORK BOOT CLAMP



Fill each fork tube with air through the air valve.

STANDARD AIR PRESSURE:

0 kPa (0 kg/cm², 0 psi)

NOTE:

- Check and adjust air pressure when the fork tubes are cold and with the front wheel off the ground, for accurate pressure readings.
- Some pressure will be lost when using the gauge. Determine the amount of loss and compensate accordingly.
- Be sure that the air pressure in both fork tubes is equal.
- Use of more than 70 kPa (0.7 kg/cm², 10 psi) is not recommended because fork action becomes very stiff.
- Depress the valve core to decrease air pressure.

AIR VALVE CAPS

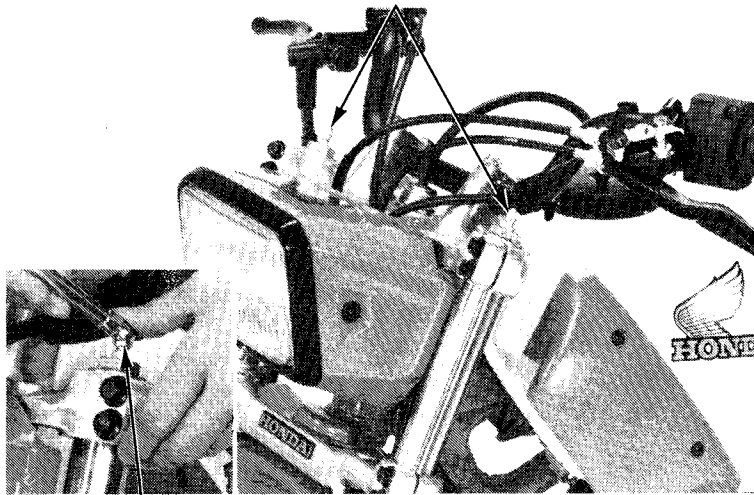

AIR VALVE

Install the air valve caps.

Install the front wheel (page 11-17).

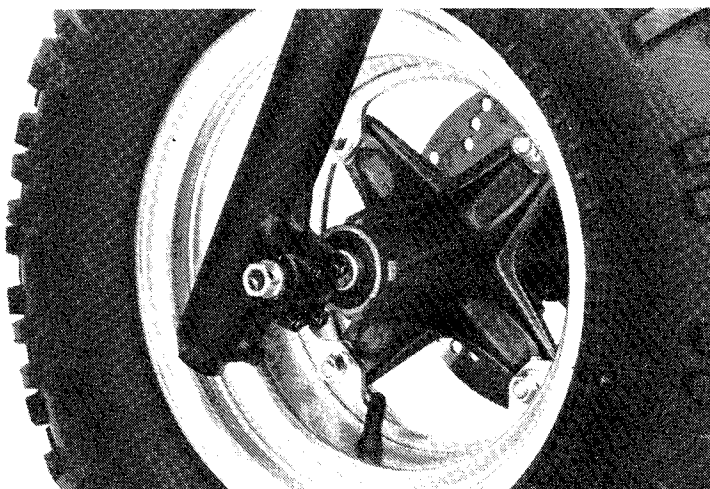

STEERING STEM

FORK BRIDGE REMOVAL

Remove the following:

- headlight and case (page 11-3).
- headlight bracket (page 11-6).
- handlebar (11-7).
- front wheel (page 11-10).
- brake hose clamps.

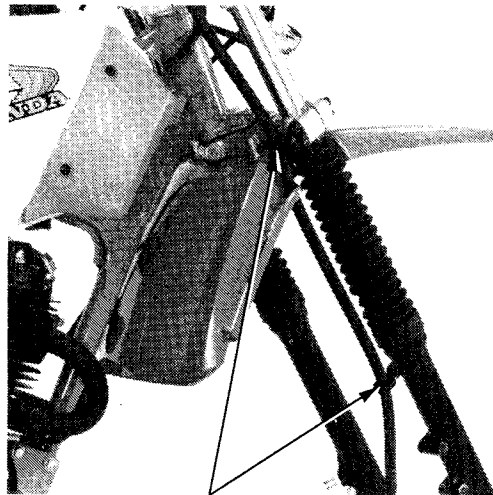

BRAKE HOSE CLAMPS

Remove the front fender.

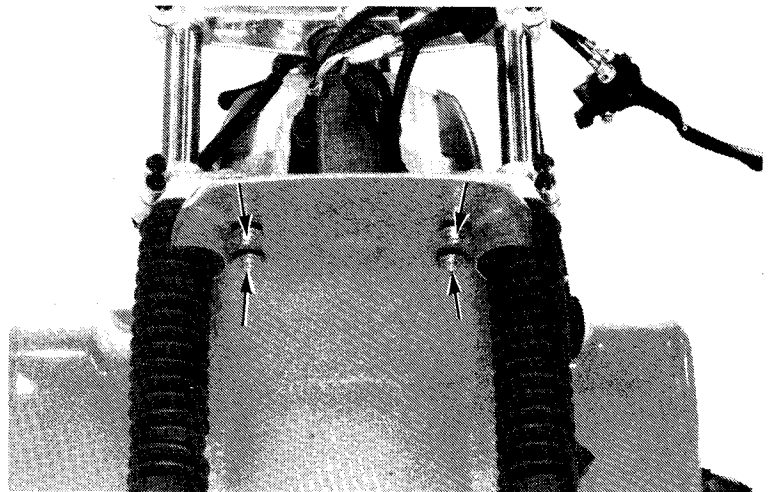

LOCK NUT WRENCH, 30 x 32 mm
07716-0020400 or equivalent

EXTENSION
07716-0020500

Loosen the fork tube pinch bolts on the fork bridge.

Remove the steering stem nut and washer.

Remove the fork bridge.

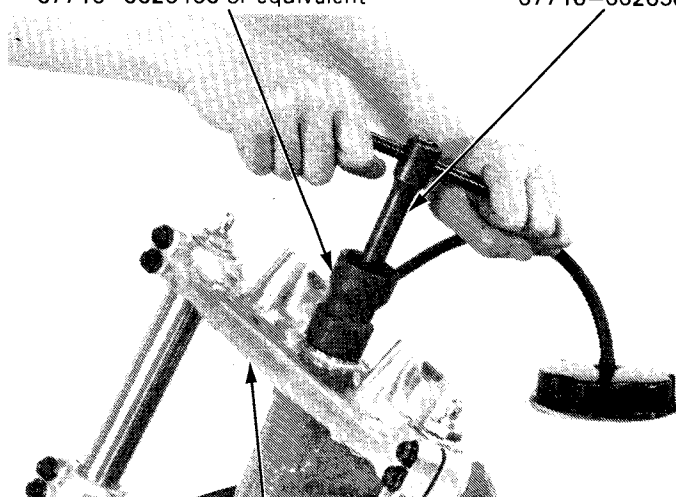

FORK TOP BRIDGE

FRONT WHEEL/FRONT FORK/STEERING

Loosen the fork tube pinch bolts on the steering stem and remove the fork tubes.
Remove the steering head top thread nut with the pin spanner.

PIN SPANNER
07702-0010000 or M9361-412-099788

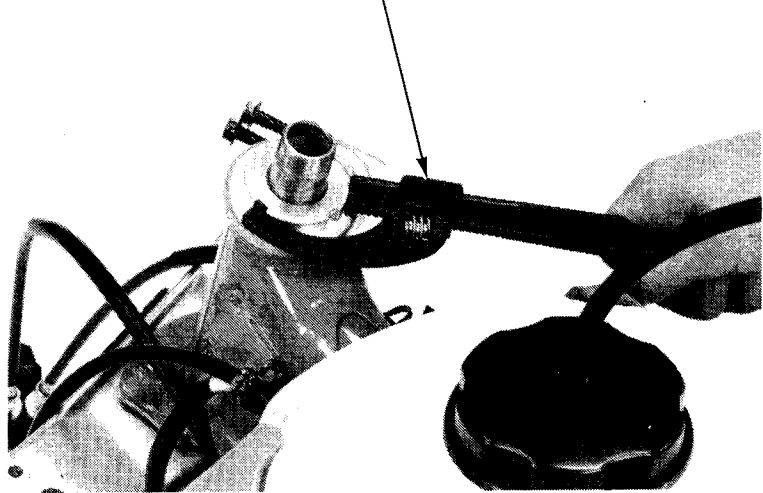

Remove the steering stem and bearings.

NOTE:

Do not allow the steel balls to fall.

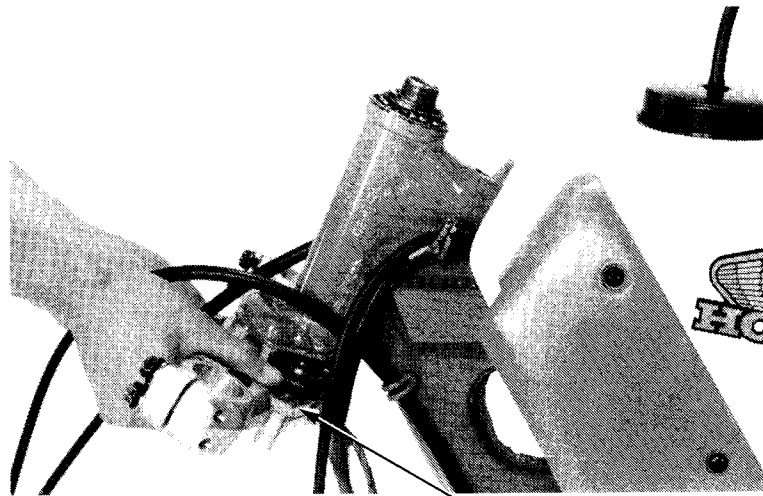

STEERING STEM

Check the cone and ball races for wear or damaged and replace if necessary.

NOTE:

Replace the balls and races as a set when any component is damaged.

TOP CONE RACE

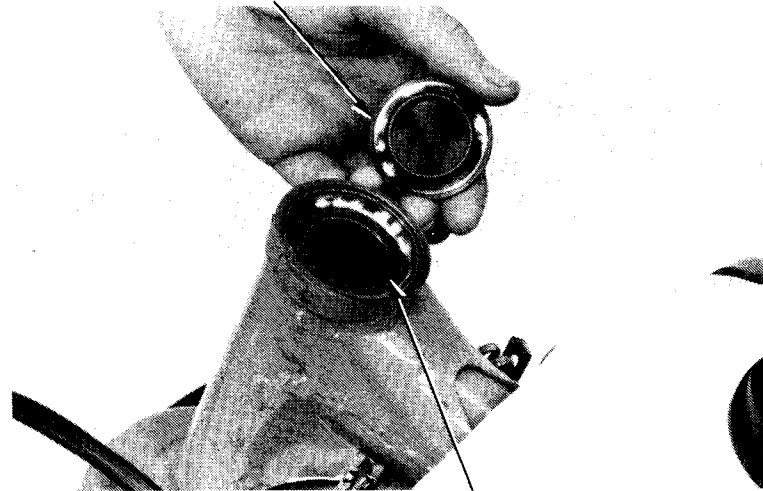

BALL RACE

FRONT WHEEL/FRONT FORK/STEERING

Remove the ball races.

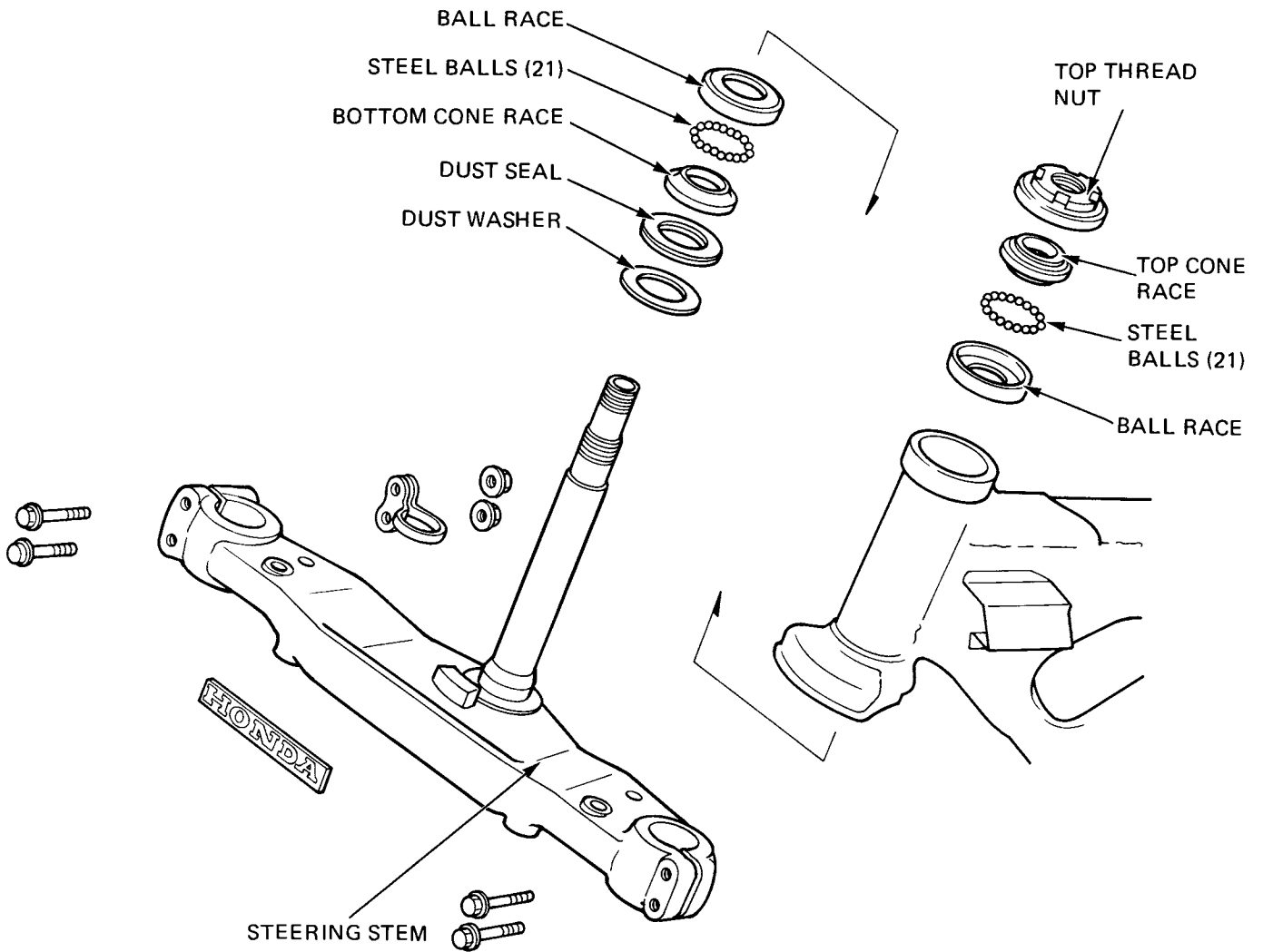
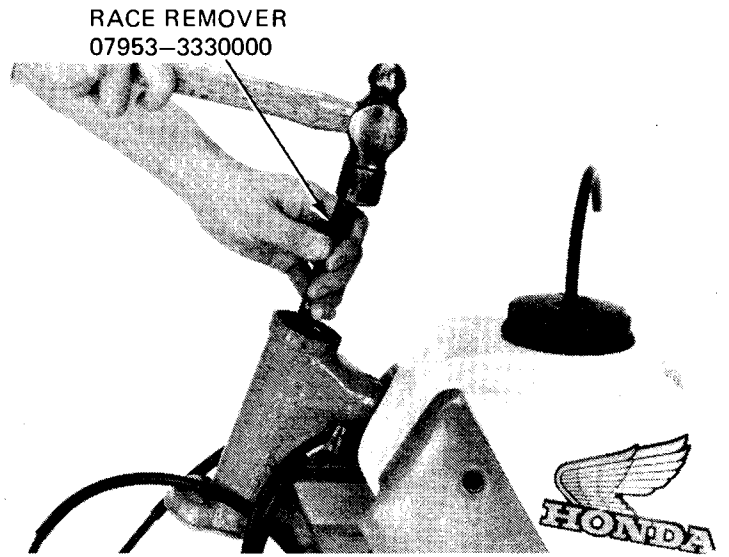

FRONT WHEEL/FRONT FORK/STEERING

STEERING STEM INSTALLATION

Install the washer and dust seal on the steering stem.

Press the bottom cone race into the steering stem.

STEERING STEM DRIVER
07946-4300001 or 07946-3710600

STEERING DRIVER ATTACHMENT
GN-HT-54 (USA only)

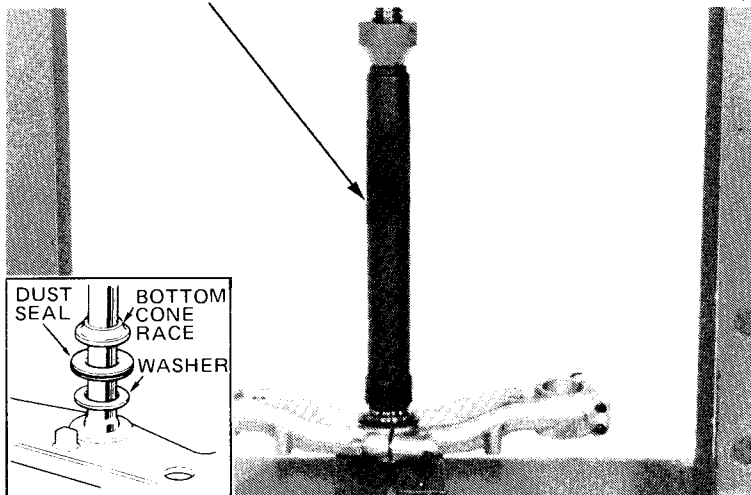

Drive in the ball races with the driver and attachment

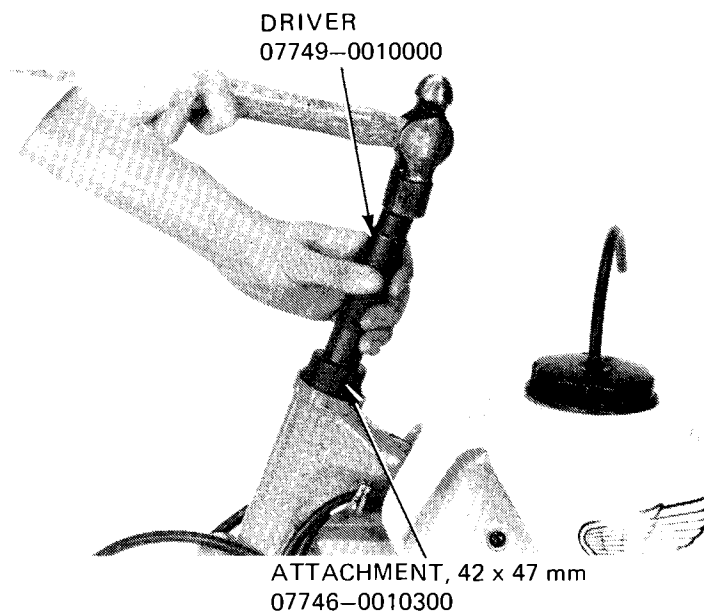

Apply grease to the ball races and cone races and install the steel balls on the races.

NOTE:

21 steel balls are used for both the top and bottom races.

Slide the steering stem through the steering head from the bottom.

Install the top cone race.
Thread on the top thread nut.

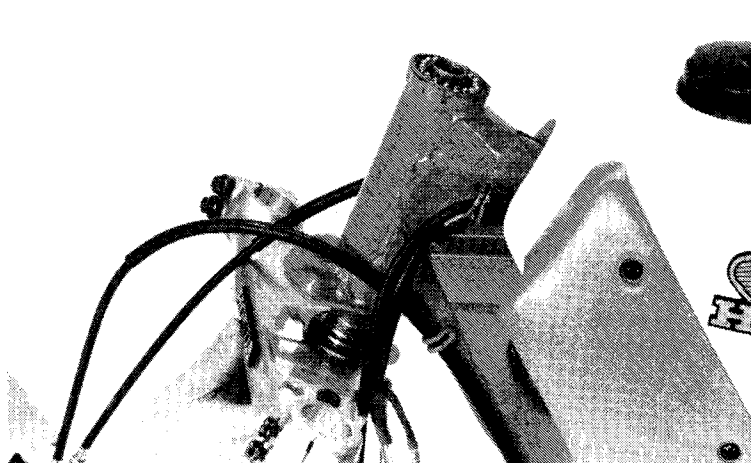

FRONT WHEEL/FRONT FORK/STEERING

Tighten the top thread nut until the stem rotates freely without axial play.

PIN SPANNER
07702-0010000 or M9361-412-099788

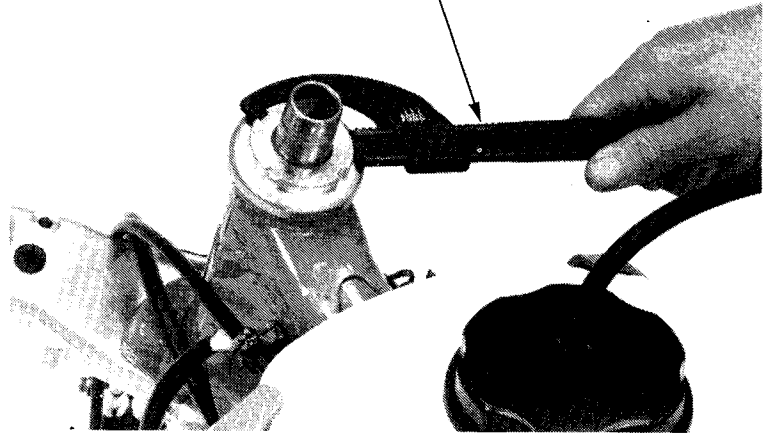

Install the fork bridge.
Install the stem washer.
Tighten the steering stem nut.

TORQUE:

70-100 N·m (7.0-10.0 kg-m, 51-72 ft-lb)

Install the front fork tubes.

Tighten the fork tube pinch bolts.

Install the following:

- front fender.
- front wheel.
- handlebar (page 11-8).
- headlight case bracket.
- headlight.

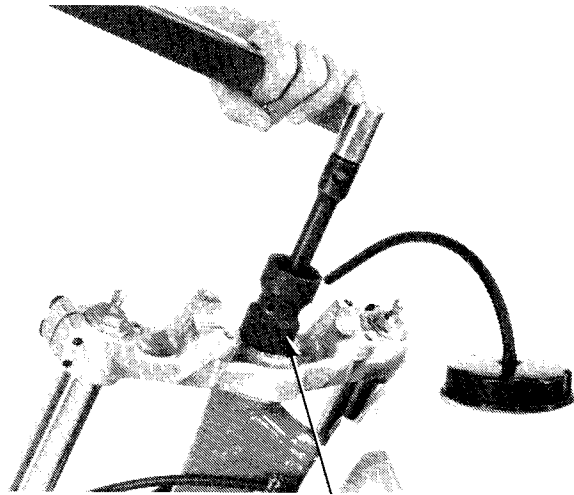

LOCK NUT WRENCH, 30 x 32 mm
07716-0020400 or equivalent

REAR WHEEL/DRIVE MECHANISM

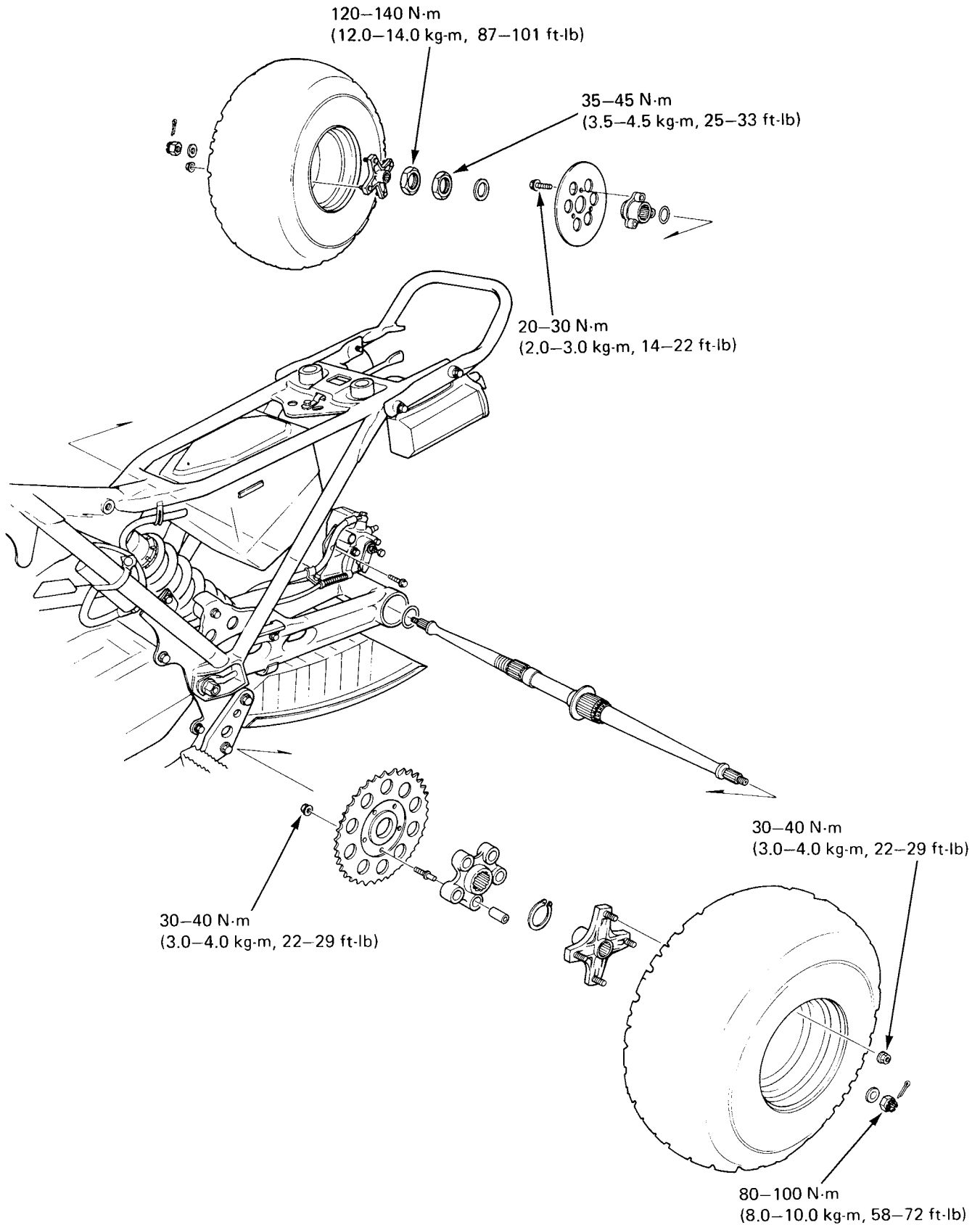

12. REAR WHEEL/DRIVE MECHANISM

SERVICE INFORMATION	12-1
TROUBLESHOOTING	12-1
REAR WHEEL	12-2
REAR AXLE	12-2

SERVICE INFORMATION

GENERAL INSTRUCTION

- This section covers maintenance of the rear wheel and drive mechanism.
- A jack or block is required to support the ATC.

SPECIFICATIONS

ITEM		STANDARD	SERVICE LIMIT
Rear axle shaft runout		——	3.0 mm (0.12 in)
Rear wheel rim runout	Radial	——	1.5 mm (0.06 in)
	Axial	——	2.0 mm (0.08 in)

TORQUE VALUES

Rear wheel hub nut		80–100 N·m (8.0–10.0 kg·m, 53–72 ft·lb)
Rear axle shaft nut	Inner	35–45 N·m (3.5–4.5 kg·m, 25–33 ft·lb)
	Outer	120–140 N·m (12.0–14.0 kg·m, 87–101 ft·lb)

TOOLS

Special

Lock nut wrench, 41 mm	07916-9580300
Lock nut spanner, 41 mm	07916-9580200
Tire sisassembly tool	GN-AH-958-BBI (U.S.A. only)

TROUBLESHOOTING

Wobble or vibraion in vehicle

1. Bent rim.
2. Loose axle shaft bearing.
3. Faulty axle shaft bearing holder.
4. Faulty tire.
5. Axle shaft not tightened properly.

REAR WHEEL/DRIVE MECHANISM

REAR WHEEL

REMOVAL

Raise the rear wheels off the ground with a jack or block under the swingarm.

Remove the rear wheel nuts.
Remove the rear wheels.

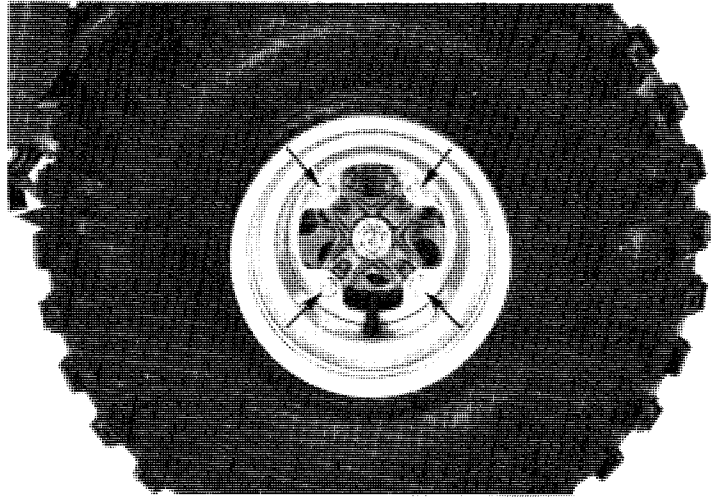

REAR TIRE DISASSEMBLY/ASSEMBLY

For tire disassembly, assembly, and repair, refer to page 11-12.

INSTALLATION

Install each rear wheel with the tire valve facing out.

Tighten the wheel nuts.

**TORQUE: 30–40 N·m (3.0–4.0 kg·m,
22–29 ft·lb)**

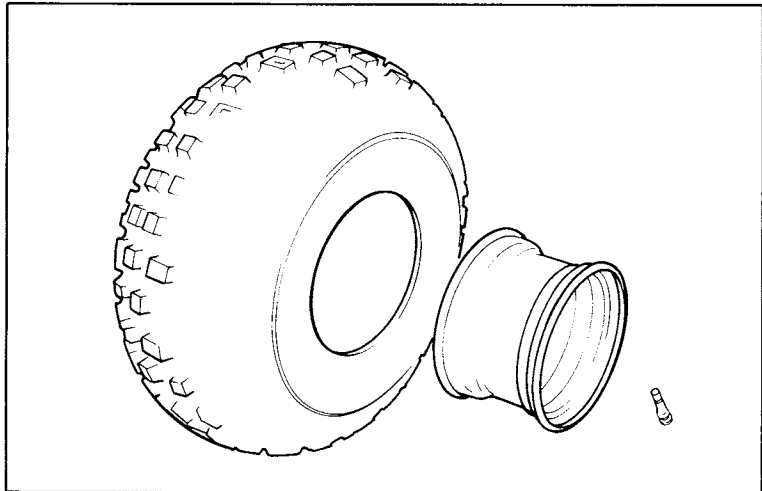

REAR AXLE

REMOVAL

Raise the rear wheels off the ground with a jack or block under the swingarm.
Remove the rear wheel nuts and rear wheels.

Remove the cotter pin from the axle shaft and loosen the wheel hub nut.
Remove the hub nuts and wheel hubs from the shaft.

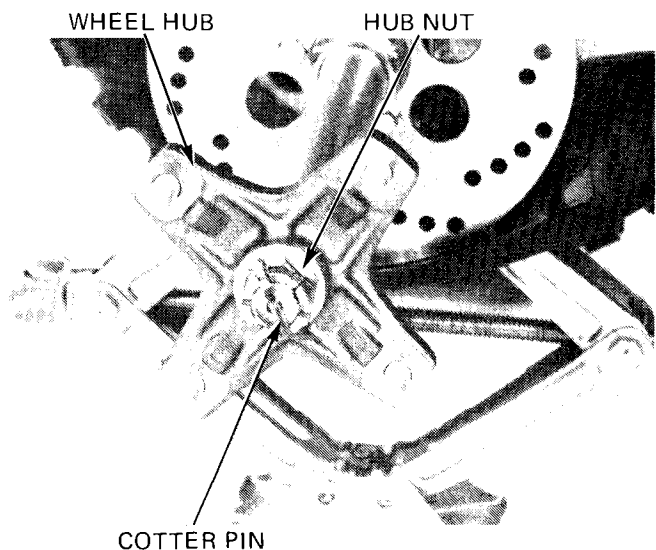

Remove the retaining clip, master link plate, O-rings and master link, and remove the drive chain from the final driven sprocket.

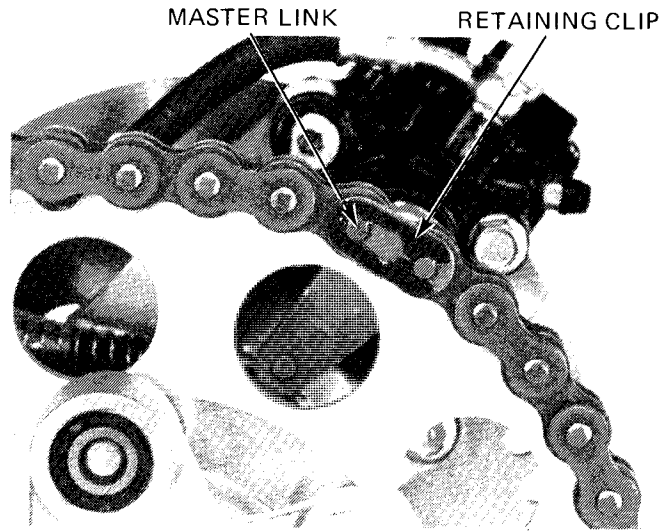

Remove the rear brake caliper from the swingarm.

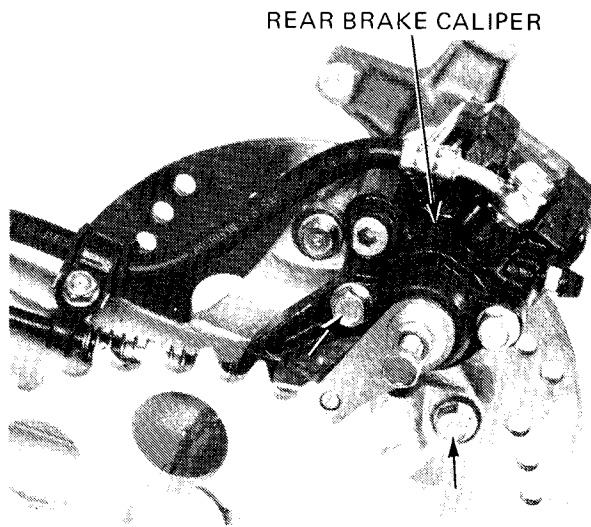

Remove the rear brake disc.

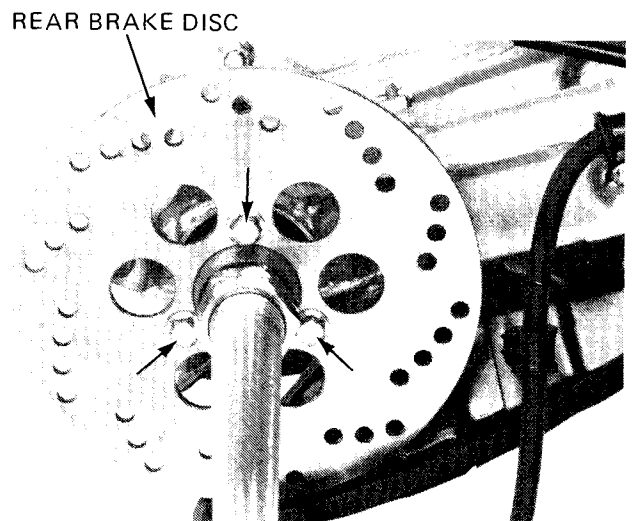

REAR WHEEL/DRIVE MECHANISM

Remove the snap ring.
Remove the final driven sprocket with the hub by tapping it with a plastic hammer from the inside.

NOTE:

The rear axle shaft can be removed with the final driven sprocket installed.

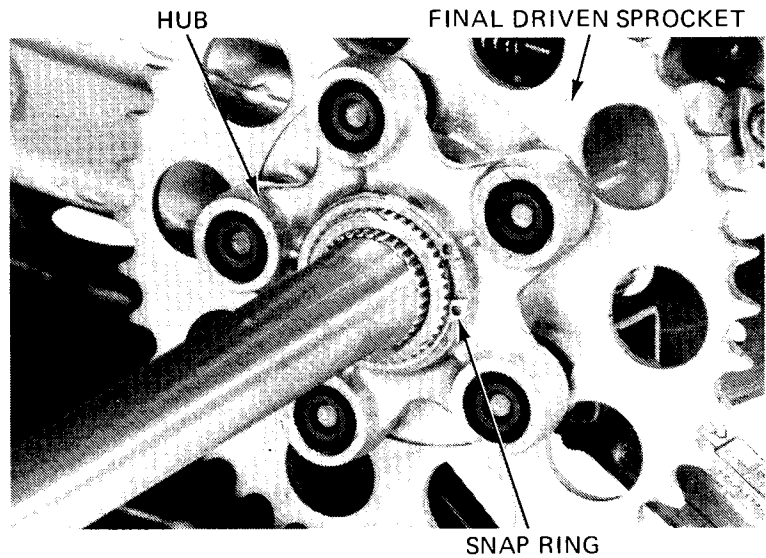

Remove the axle shaft nuts with 41 mm lock nut wrenches or equivalent tool commercially available in U.S.A.

Remove the rear brake disc hub.

Remove the rear axle shaft from the swingarm.

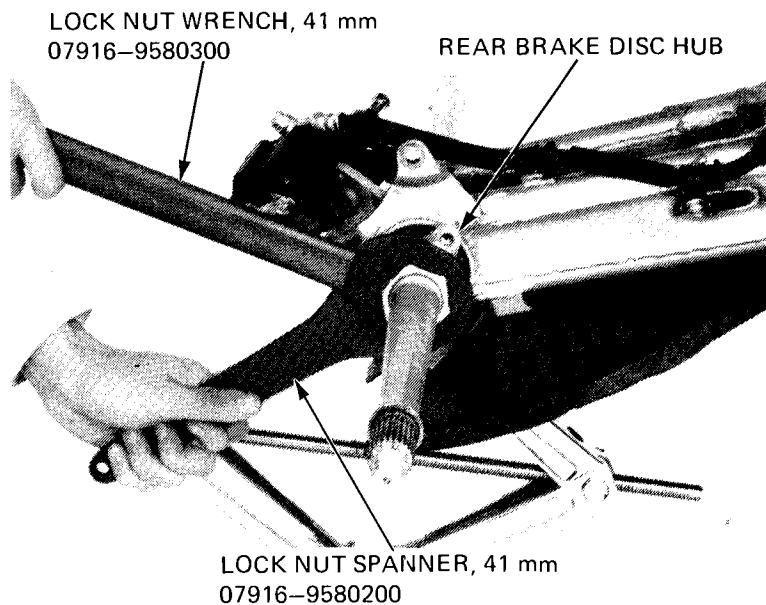

INSPECTION

REAR AXLE SHAFT RUNOUT

Place the axle shaft in V-blocks and measure the runout.

SERVICE LIMIT: 3.0 mm (0.12 in)

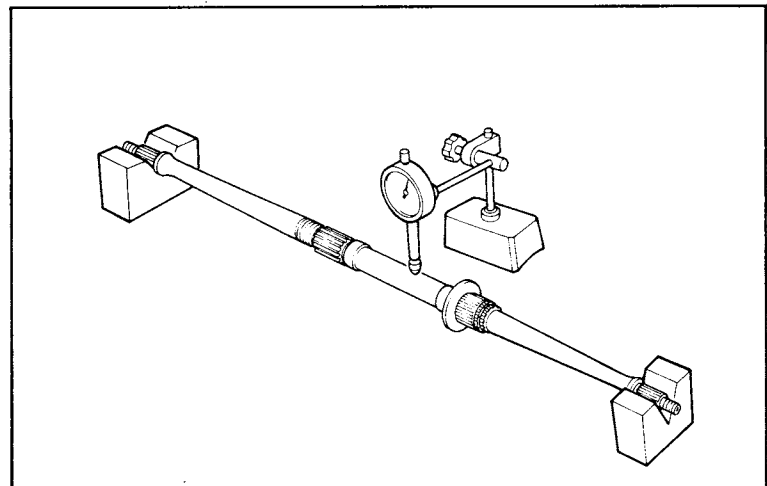

REAR AXLE SHAFT BEARING INSPECTION

Check the rear axle shaft bearings. Replace any bearing that is noisy or has excessive play.

Refer to section 13 for bearing replacement.

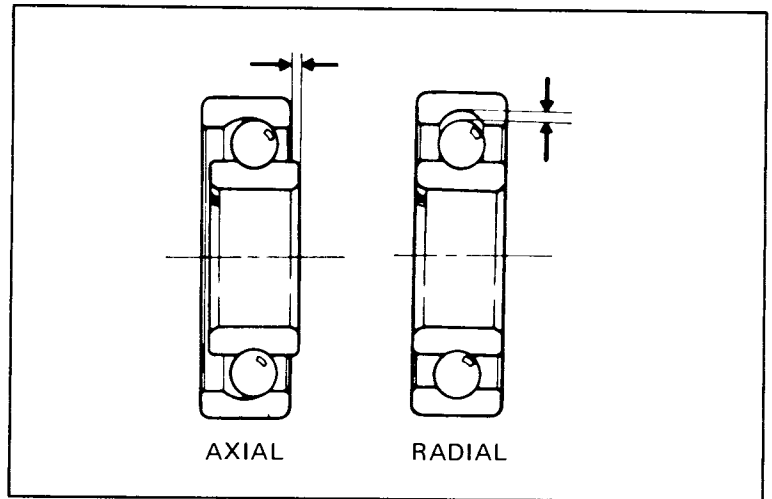

FINAL DRIVEN SPROCKET INSPECTION

Check the condition of the final driven sprocket teeth.

Replace the sprocket if it is worn or damaged.

NOTE:

If the driven sprocket is worn or damaged, the drive chain and drive sprocket must be inspected.

Never install new drive chain on worn sprockets or a worn chain on new sprockets.

The chain and both sprockets must be in good condition or the replacement chain or sprockets will wear rapidly.

Check the damper rubbers in the sprocket hub for damage.

Replace the hub if the damper rubbers are damaged.

INSTALLATION

Slide the axle through the swingarm.

Install the axle inner nut and tighten to the specified torque.

TORQUE: 35–45 N·m (3.5–4.5 kg·m, 25–33 ft·lb)

Clean any grease or dirt off the axle threads and apply LOCKTITE® or equivalent to the threads.

Hold the inner nut with a 41 mm wrench and tighten the outer nut, also with a 41 mm wrench.

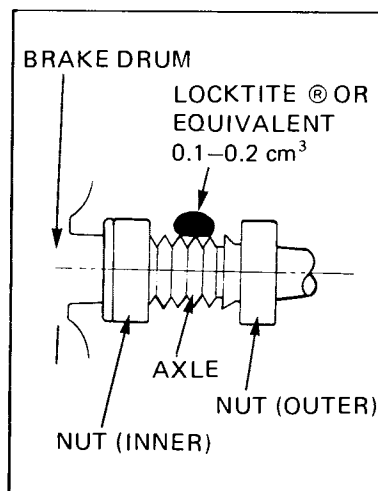

LOCK NUT SPANNER, 41 mm
07916–9580200

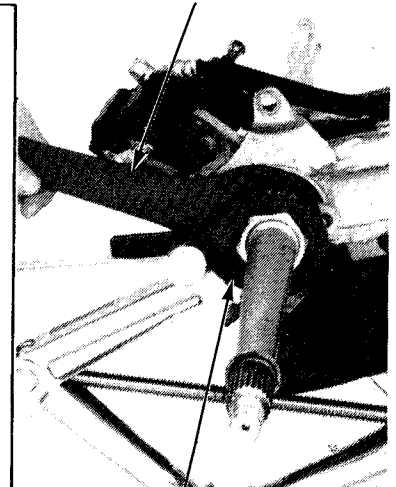

LOCK NUT WRENCH, 41 mm
07916–9580300

REAR WHEEL/DRIVE MECHANISM

Install the final driven sprocket with the hub.
Install the snap ring.

CAUTION:

Install the snap ring with the chamfered side toward the sprocket.

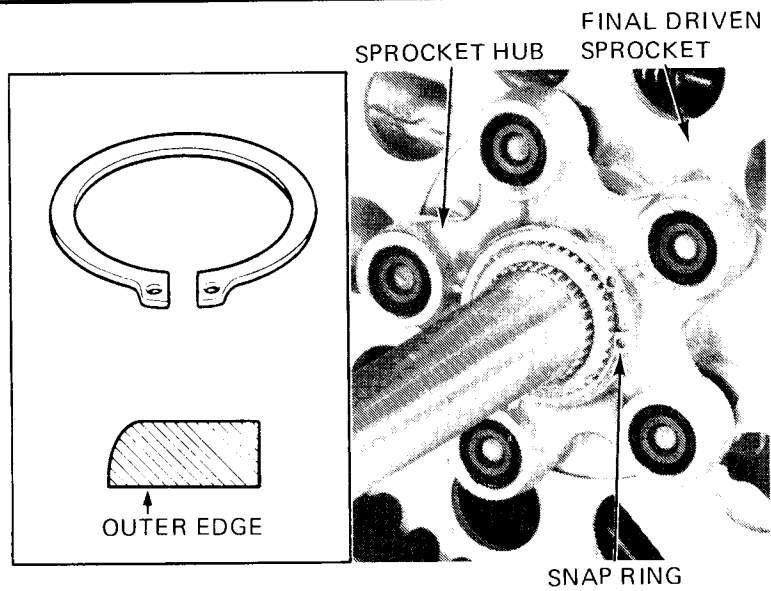

Install the rear brake disc.

TORQUE: 20–30 N·m (2.0–3.0 kg·m,
14–22 ft·lb)

REAR BRAKE DISC

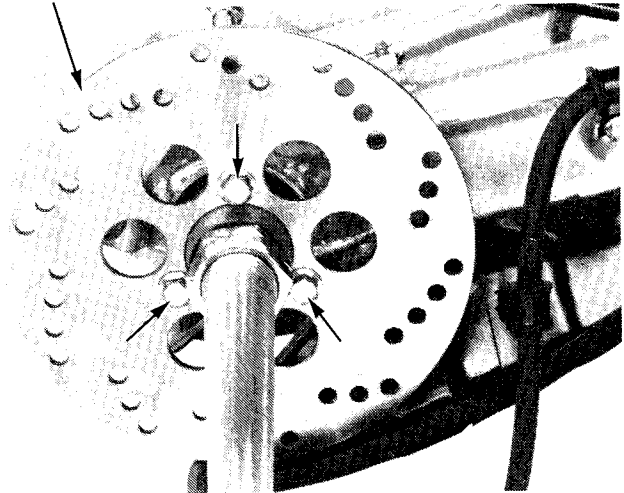

REAR BRAKE CALIPER

Install the rear brake caliper so the brake disc is positioned between the pads, making sure not to damage the pads.

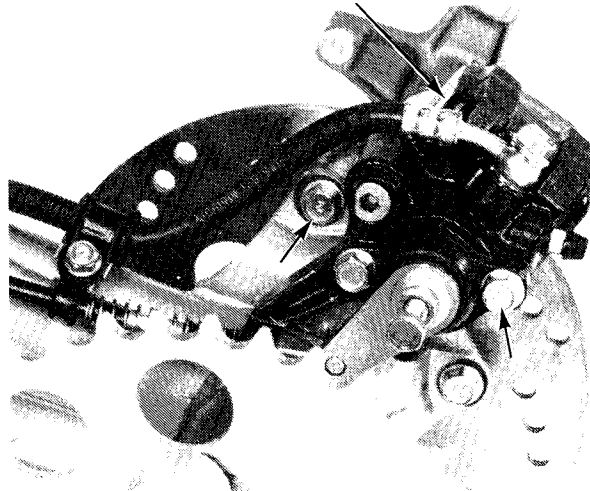

Install the drive chain over the final driven sprocket.
Install the master link with O-rings, link plate and retaining clip.

NOTE:

The closed end of the clip should face the normal rotating direction of the drive chain.

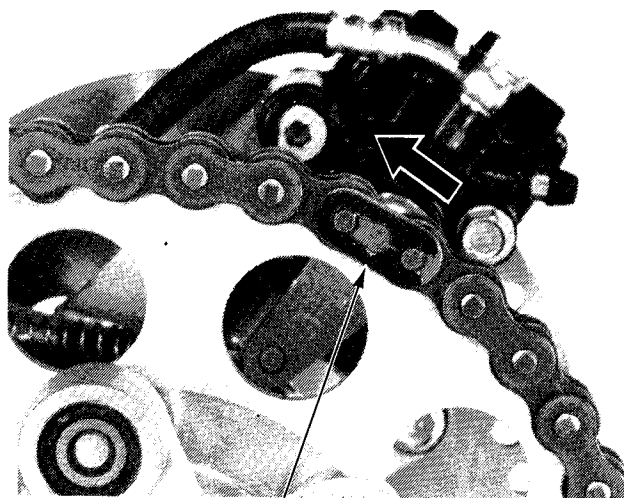

RETAINING CLIP

Install the rear wheel hubs on the axle shaft.
Tighten the wheel hub nuts.

TORQUE:

80–100 N·m (8.0–10.0 kg·m, 58–72 ft·lb)

Install a new cotter pin.

Install the rear wheels (page 12-2).

Adjust the drive chain slack (page 3-9).

Adjust the parking brake (page 3-12).

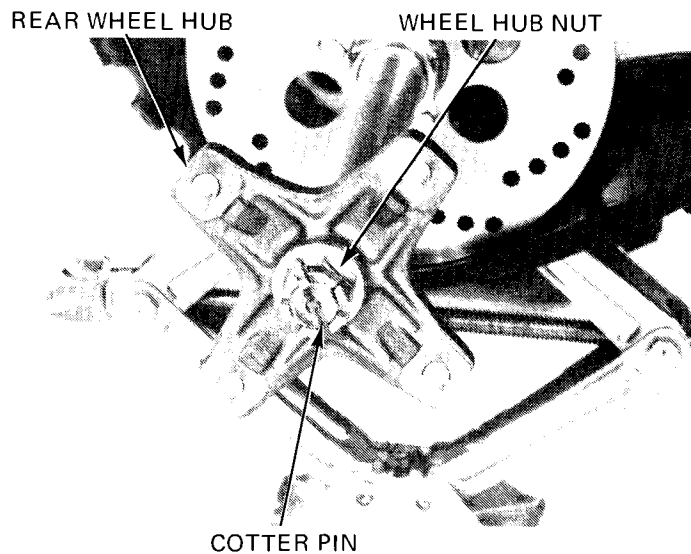

COTTER PIN

REAR SUSPENSION

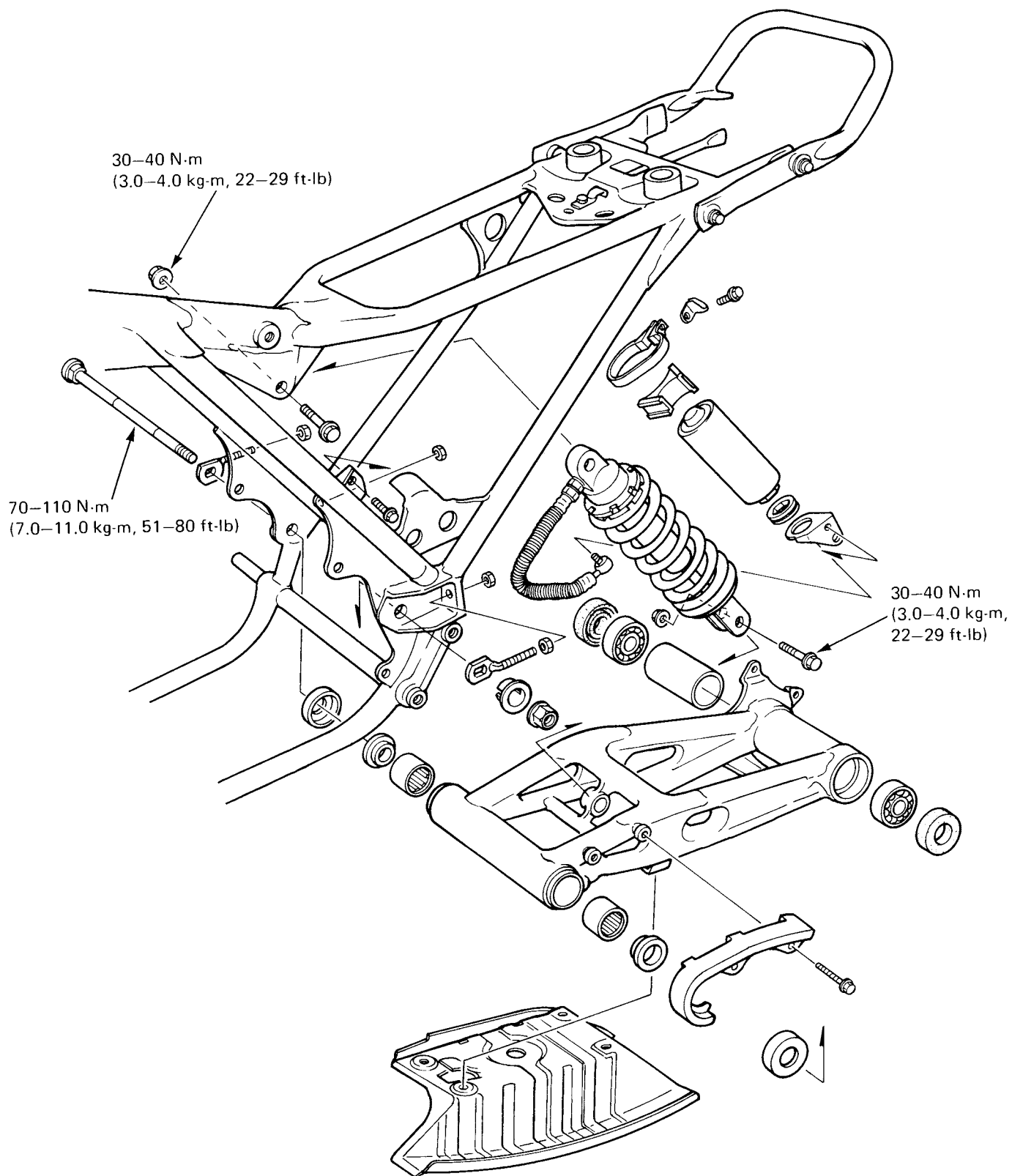

13. REAR SUSPENSION

SERVICE INFORMATION	13-1
TROUBLESHOOTING	13-1
REAR SHOCK ABSORBER	13-2
SWINGARM	13-10

SERVICE INFORMATION

GENERAL

- This section deals with rear shock absorber and swingarm repairs.
- A jack or block is required to support the ATC.

SPECIFICATIONS

ITEM	STANDARD	SERVICE LIMIT
Rear shock absorber spring free length	202.4 mm (7.97 in)	195 mm (7.7 in)
Reservoir nitrogen gas pressure	2,000 ± 200 kPa (20 ± 2 kg/cm ² , 284 ± 28 psi)	—

TORQUE VALUE

Swingarm pivot bolt 70–110 N·m (7.0–11.0 kg·m, 51–80 ft·lb)

TOOLS

Special

Swingarm Bushing/Bearing Remover M967X-038-XXXXX (U.S.A. only)
Bearing Remover, 20 mm 07936-3710600
Remover Handle 07936-3710100
Remover Weight 07741-0010201

Common

Pilot, 20 mm 07746-0040500
Attachment, 32 x 35 mm 07746-0010100
Attachment, 62 x 68 mm 07746-0010500
Pilot, 35 mm 07746-0040800
Driver 07749-0010000

Optional

Pin Spanner 89201-KA4-810
Pin Spanner 89202-KA4-810

13

TROUBLESHOOTING

Soft suspension

1. Weak spring.
2. Improper rear suspension adjustment.
3. Insufficient nitrogen pressure.

Suspension noise

1. Loose fasteners.

Hard suspension

1. Improper spring adjustment.
2. Excessive nitrogen pressure.
3. Bent shock absorber rod.

Wobble or vibration

1. Worn swingarm bushings.
2. Loose swingarm pivot bolt.

REAR SUSPENSION

REAR SHOCK ABSORBER

REMOVAL

Remove the seat/rear fender.
Raise the rear wheels off the ground with a jack or block under the engine.
Remove the reservoir setting band and mount rubber.
Remove the reservoir mount bracket bolt and removed the reservoir.

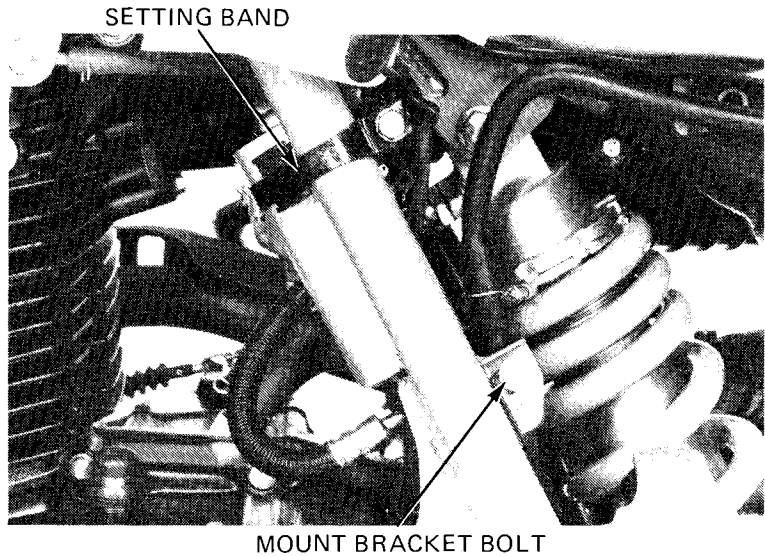

Remove the rear shock absorber upper and lower mount bolts and remove the rear shock absorber from the frame.

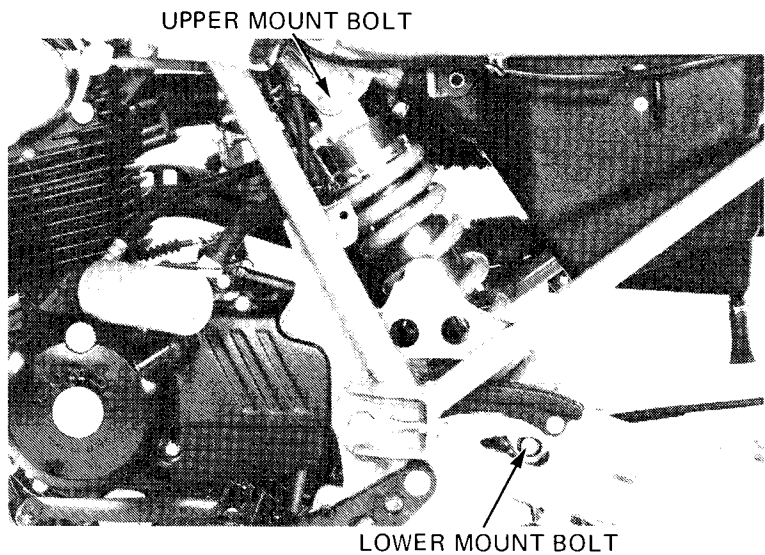

REAR SHOCK ABSORBER DISASSEMBLY

WARNING

The rear shock absorber contains nitrogen under high pressure. Do not allow flames or heat near the shock absorber.

Hold the lower eye of the shock absorber in a vise with soft jaws.

Loosen the lock nut.

CAUTION:

Be careful not to damage the hose connection in the vise.

NOTE:

The pin spanners are optional tools.

PIN SPANNERS (OPTIONAL TOOLS)
89201-KA4-810, 89202-KA4-810

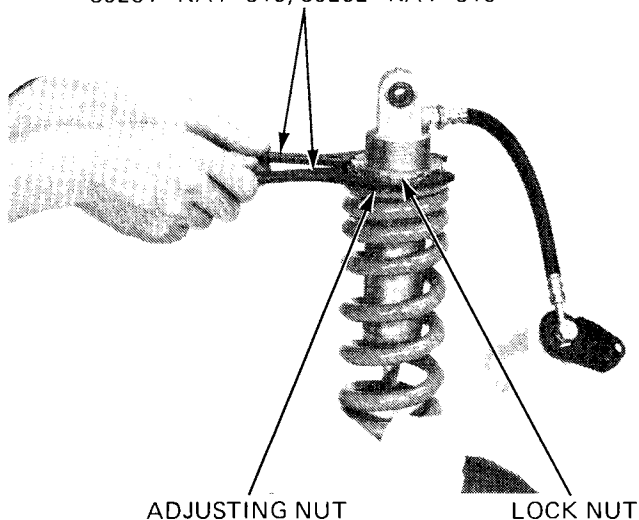

Loosen the adjusting nut until the spring tension is released.
Remove the spring seat stopper, spring seat and spring.

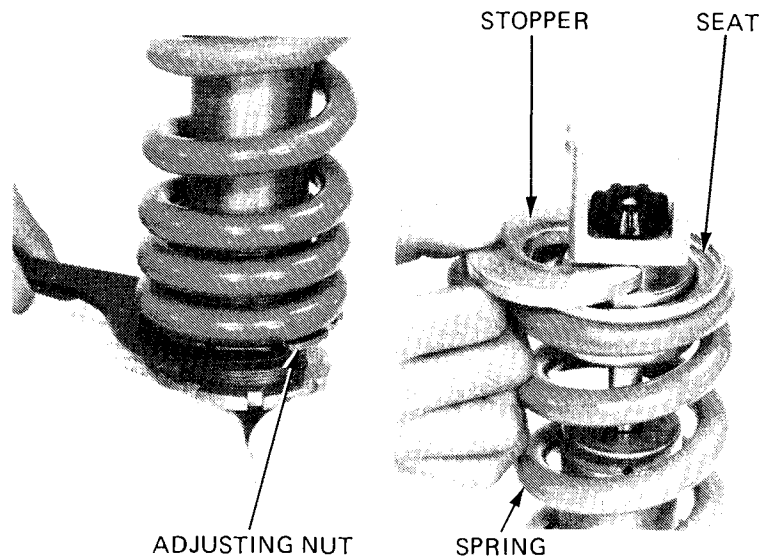

SHOCK ABSORBER SPRING INSPECTION

Measure the spring free length.

SERVICE LIMIT: 197.4 mm (7.77 in)

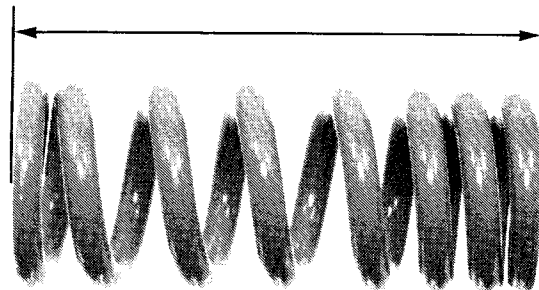

DAMPER UNIT INSPECTION

Visually inspect the damper unit for dents, oil leaks or other faults. Replace the damper unit if necessary.

Place the damper rod on a scale and measure the force required to compressed the damper unit 10 mm (0.4 in).

COMPRESSION FORCE: 28–30 kg (62–66 lbs)

If the force required is less than 28 kg (62 lbs), gas is leaking. Examine the damper rod and replace the damper unit if bent or scored.

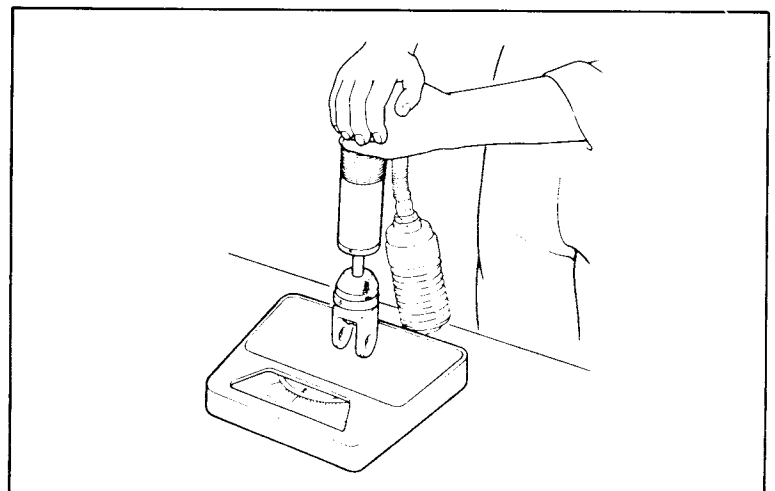

REAR SUSPENSION

Remove the cap from the reservoir.

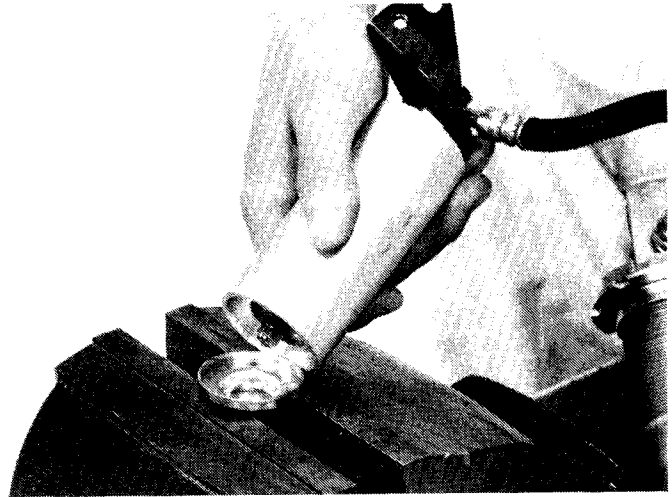

Depress the valve core to release the nitrogen from the reservoir.

WARNING

- *Be sure the release nitrogen gas pressure before disassembly.*
- *Point the valve away from you.*
- *Wear appropriate eye protection.*

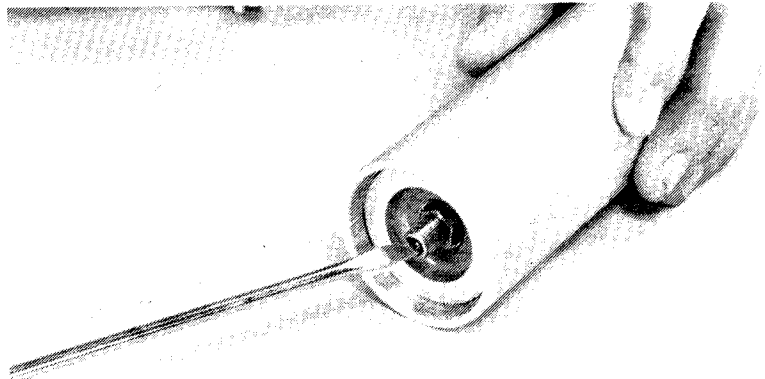

Remove the banjo bolt and disconnect the hose from the reservoir.

Loosen the lock nut and disconnect the hose from the damper unit.

Remove the spring lock nut and adjusting nut from the damper unit.

CAUTION:

Do not disassemble the damper unit.

Drain the oil from the reservoir, hose and damper unit.

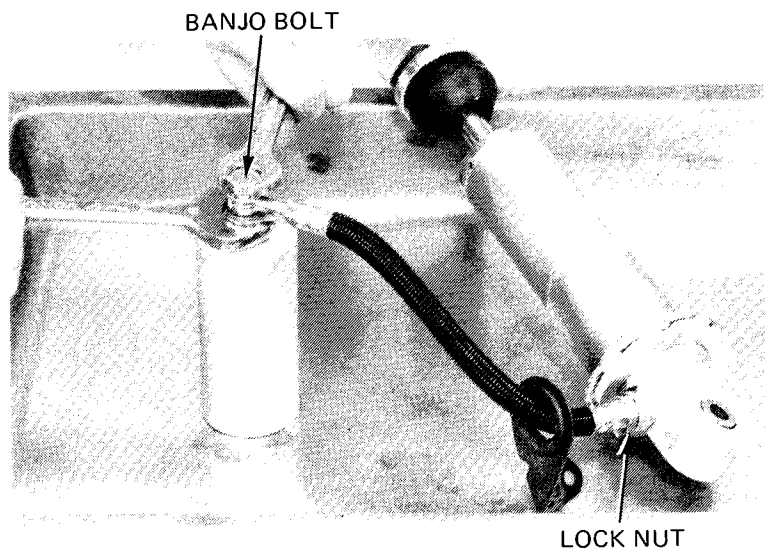

ASSEMBLY

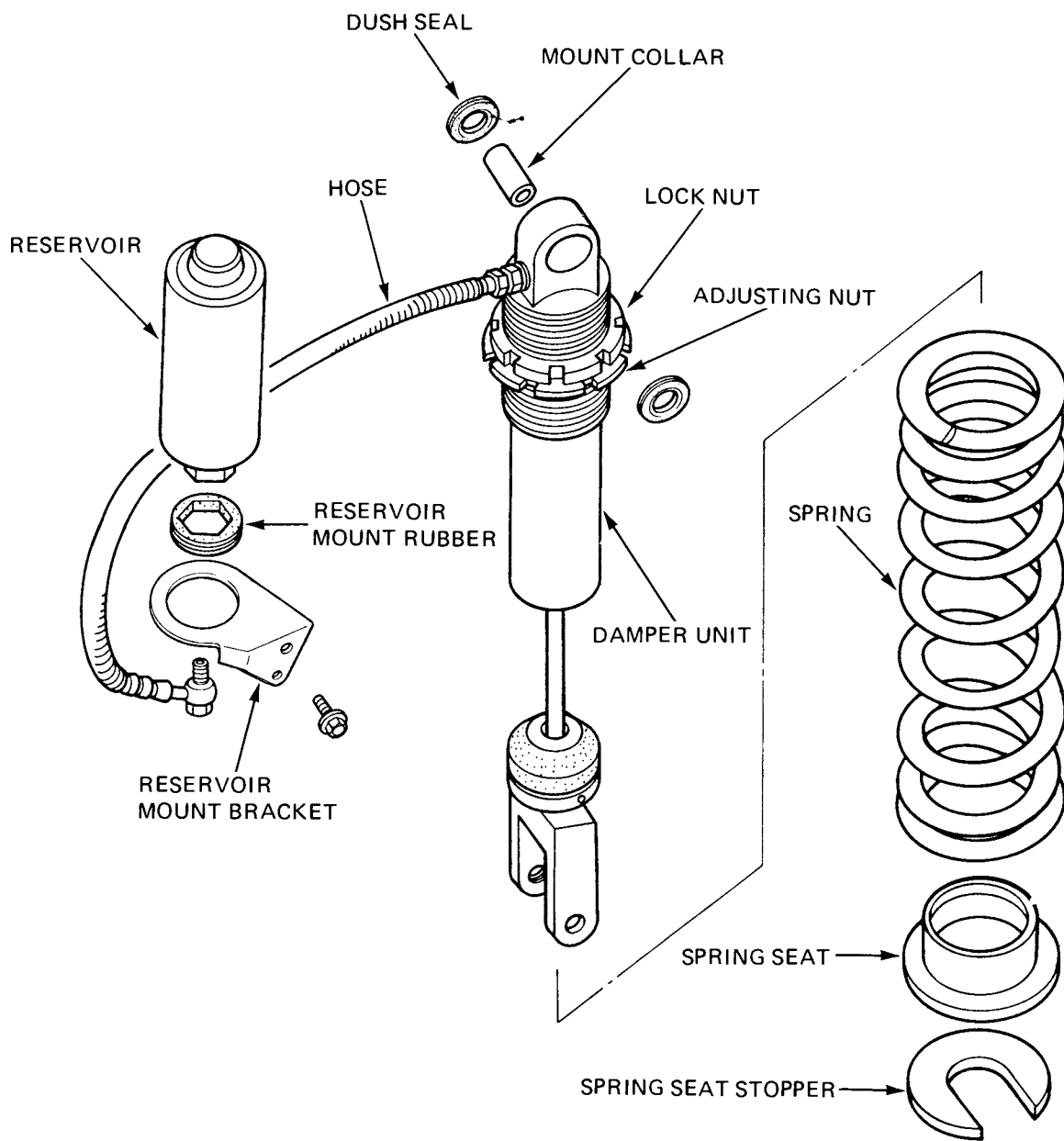

REAR SUSPENSION

Thread the spring adjusting nut and lock nut onto the damper unit.

Tilt the damper unit in a vise as shown.

Compress the damper rod fully and pour oil into the damper unit.

RECOMMENDED OIL: ATF

Fill the damper unit with ATF by pulling out the damper rod all the way.

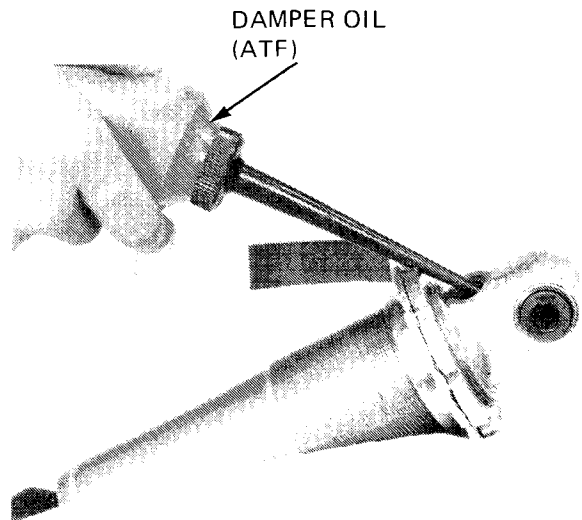

Pump the damper rod several times slowly to bleed air from the damper.

Fill the damper unit with ATF again.

NOTE:

Bleed air from the damper unit thoroughly.

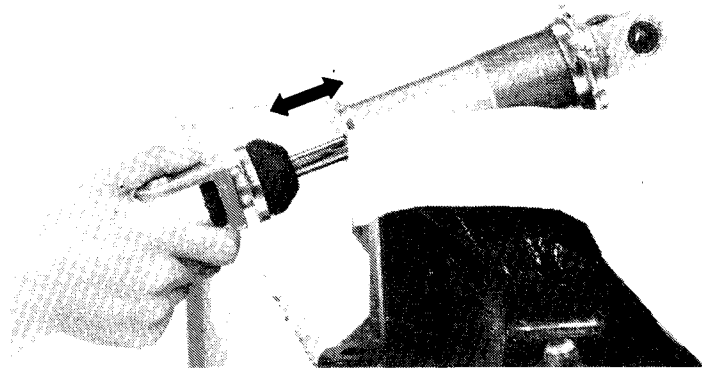

Fill the reservoir with ATF.

NOTE:

Make sure that there is no gas pressure in the reservoir.

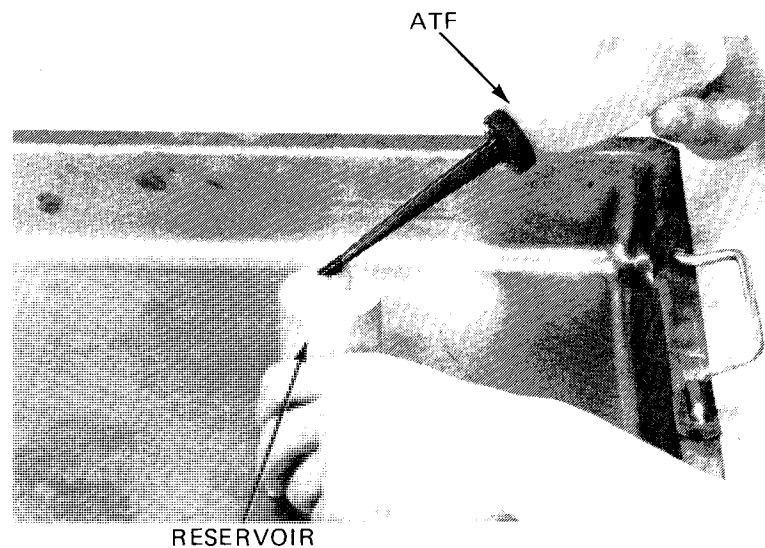

Install the O-ring on the hose joint.
Fill the hose with ATF.

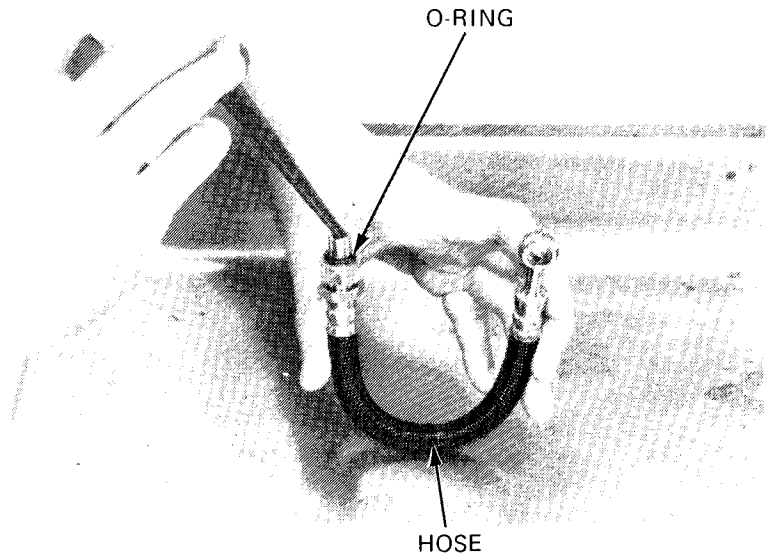

Connect the hose to the damper unit.

Tighten the hose joint.

**TORQUE: 27.5–32.5 N·m (2.75–3.25 kg-m,
20–23 ft-lb)**

Fill the hose with ATF again. Make sure that the damper rod is pulled out fully when filling the hose.

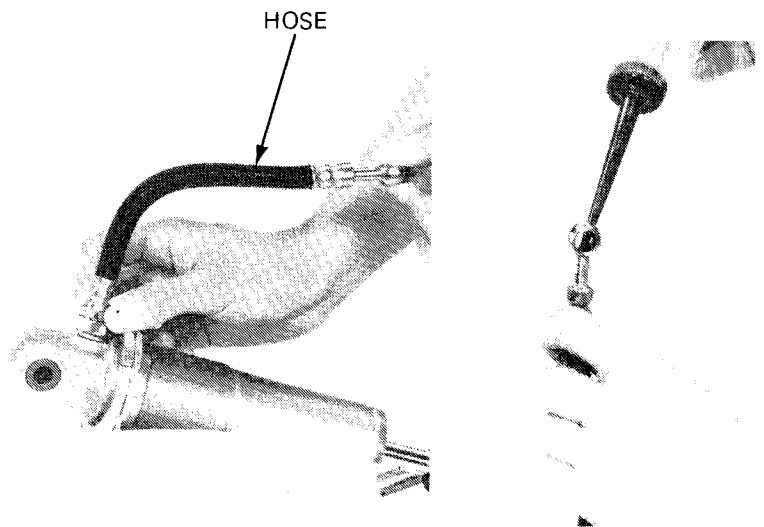

Connect the reservoir to the hose.

NOTE:

Do not allow air to enter the ATF.

Tighten the hose banjo bolt.

**TORQUE: 27.5–32.5 N·m (2.75–3.25 kg-m,
20–23 ft-lb)**

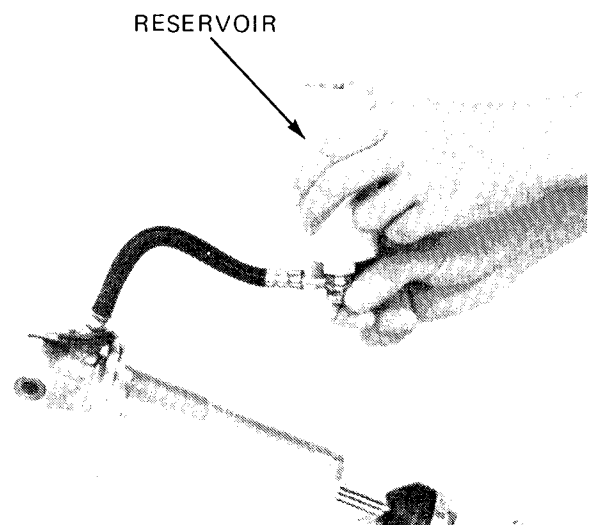

REAR SUSPENSION

Check the damper for the presence of air in the ATF by moving the damper rod in and out.

If operation is irregular, remove the hose and bleed air from the damper.

Pressurize the reservoir with nitrogen gas.

SPECIFIED GAS PRESSURE:
2000 kPa (20 kg/cm², 284 psi)

WARNING

Maintain the pressure to the specified gas pressure.

Check the damper compression force is within specification (page 13-3).

COMPRESSION FORCE: 28–30 kg (62–66 lbs)

Install the reservoir cap.

WARNING

Use only nitrogen to pressurize the shock absorber. The use of an unstable gas can cause a fire or explosion.

Install the spring, spring seat and spring stopper onto the damper.

Turn the adjuster nut to obtain the standard spring length.

STANDARD SPRING LENGTH: 195 mm (7.7 in)

Tighten the lock nut securely.

NOTE:

One turn equals 1.5 mm (0.06 in).

To increase spring preload tighten the adjusting nut to shorten the spring length up to 5 mm (0.2 in).

CAUTION:

Do not adjust the spring more than 5 mm (0.2 in) shorter than the standard length, or damage to the spring will result.

To reduce spring preload; loosen the adjusting nut to increase spring length up to 5 mm (0.2 in).

WARNING

Do not ride the motorcycle without the spring having preload. Loss of rider control could result.

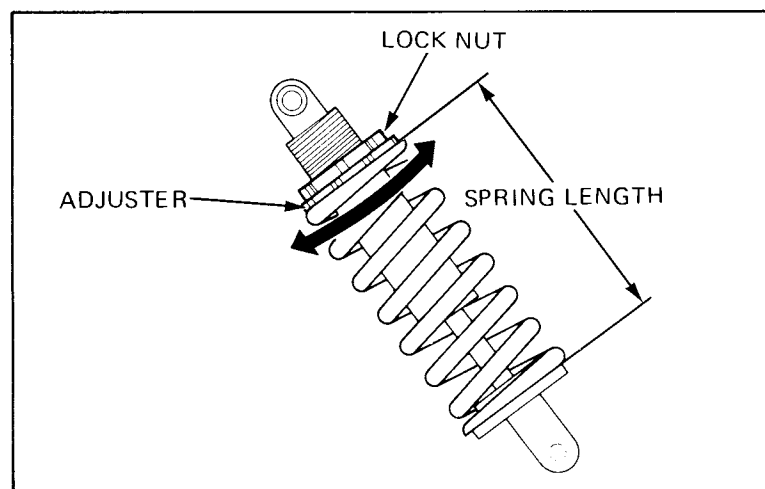
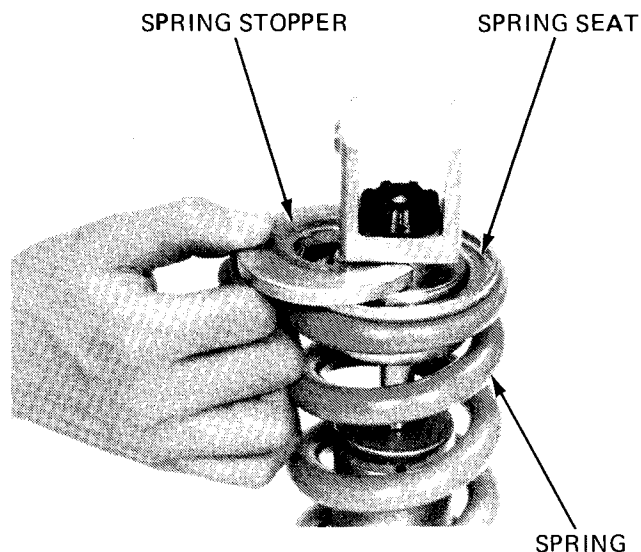
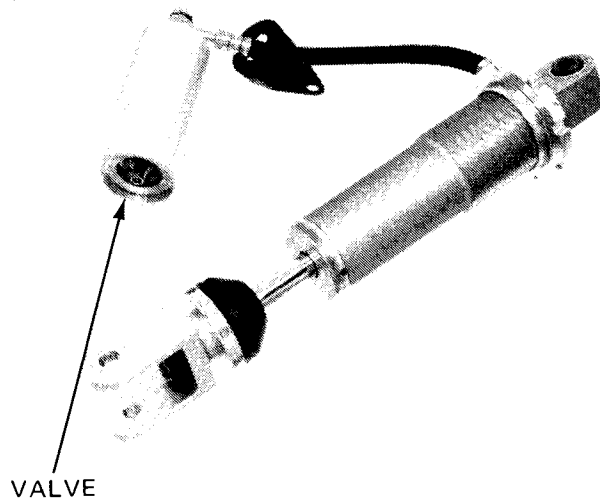

REAR SHOCK ABSORBER INSTALLATION

Install the shock absorber lower mount with the threaded side facing the right side.
Install the lower mount bolt from the left side.

Apply MoS₂ (molybdenum disulfide grease) to the shock absorber upper mount bushing.

NOTE:

Use MoS₂ paste (containing more than 45% of MoS₂) as follows:

- MOLYKOTE® G-n PASTE manufactured by Dow Corning, U.S.A.
- ROCOL PASTE manufactured by Sumico Lubricant Co., Ltd., Japan.
- Other lubricants of equivalent quality.

Place the shock absorber upper mount into the bracket.

Install the upper mount bolt and nut.
Tighten the upper mount nut and lower mount bolt.

TORQUE: 30–40 N·m (3.0–4.0 kg·m,
22–29 ft·lb)

WARNING

Use only the correct bolts. Do not substitute other fasteners, since they may not have adequate strength and may fail during operation.

Install the reservoir bracket to the frame and tighten the bolt.

Position the reservoir with the mount rubber and secure it with the setting band.

Install the seat/rear fender.

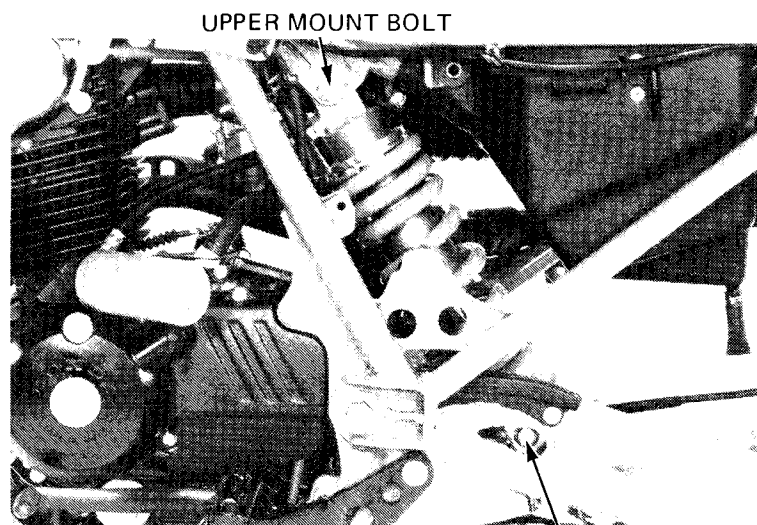

UPPER MOUNT BOLT

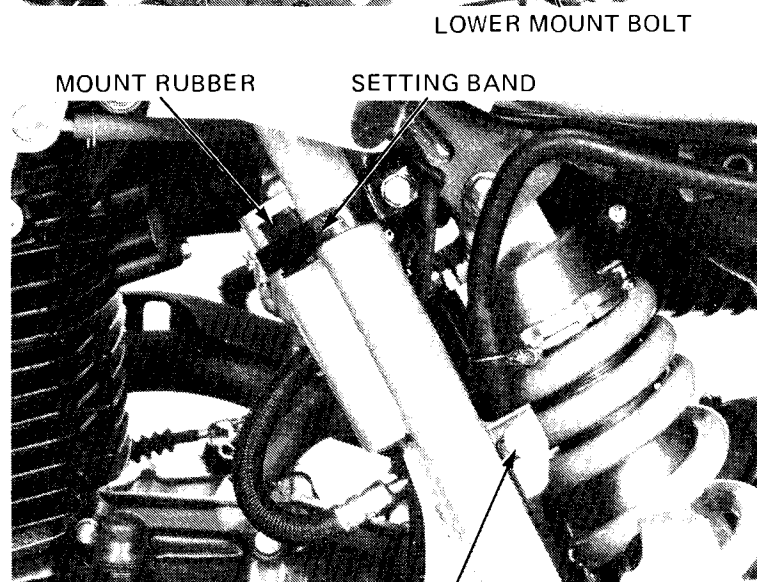

LOWER MOUNT BOLT

MOUNT RUBBER

SETTING BAND

BRACKET MOUNT BOLT

REAR SUSPENSION

SWINGARM

REMOVAL

Remove the rear axle shaft (page 12-2).

Remove the brake hose clamps.

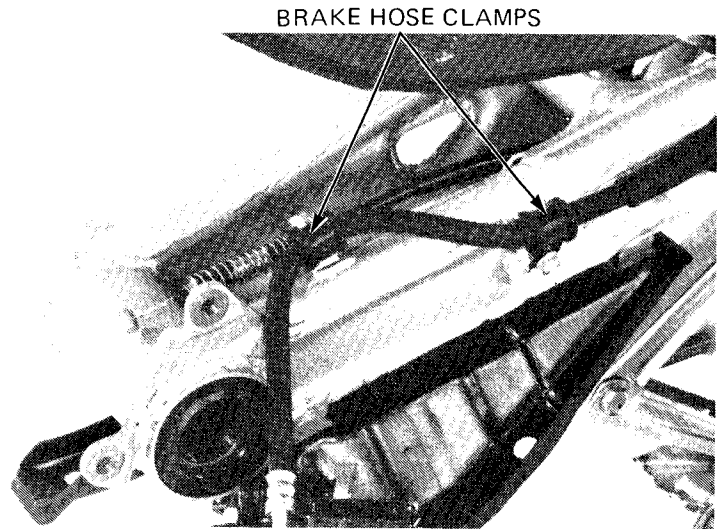

Remove the rear shock absorber lower mount bolt.

Remove the swingarm pivot bolt and remove the swing arm.

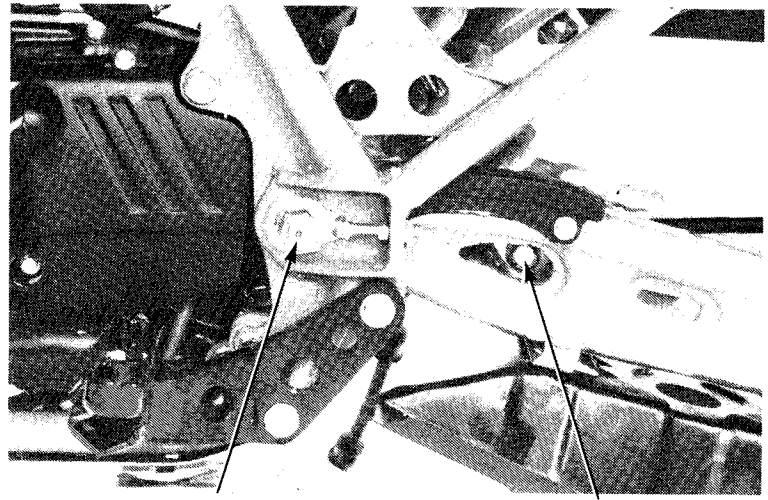

DISASSEMBLY

Remove the dust covers.

Remove the drive chain slider.

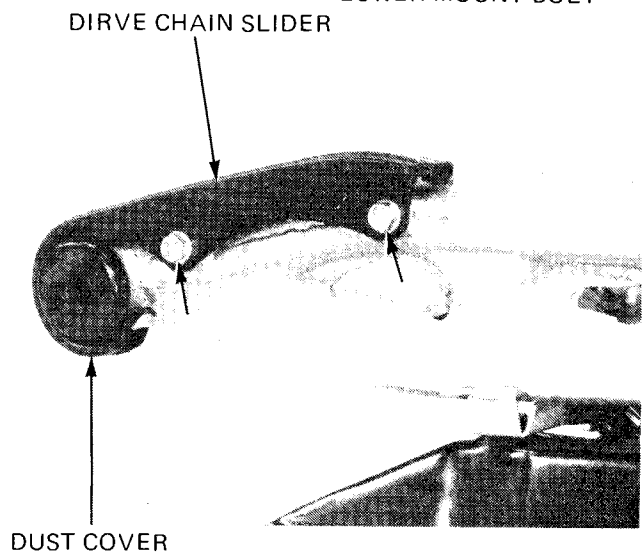

Remove the following:

- skid plate.
- axle shaft dust seals and ball bearings with a drift punch.
- axle shaft collar.
- swingarm pivot thrust bushings and needle bearings with:

Bearing Remover (07936-3710600)

Remover Handle (07936-3710100)

Remover Weight (07741-0010201)

or

S/A Bearing/Bushing Remover

M967X-038-XXXXX (U.S.A. only)

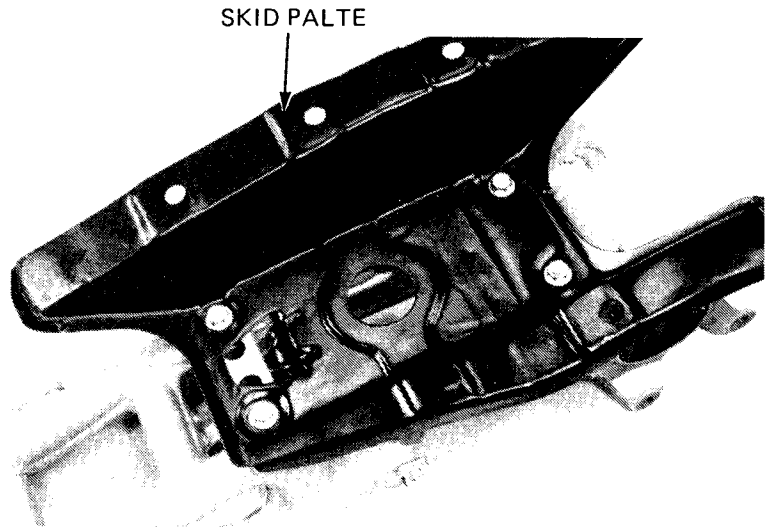

ASSEMBLY

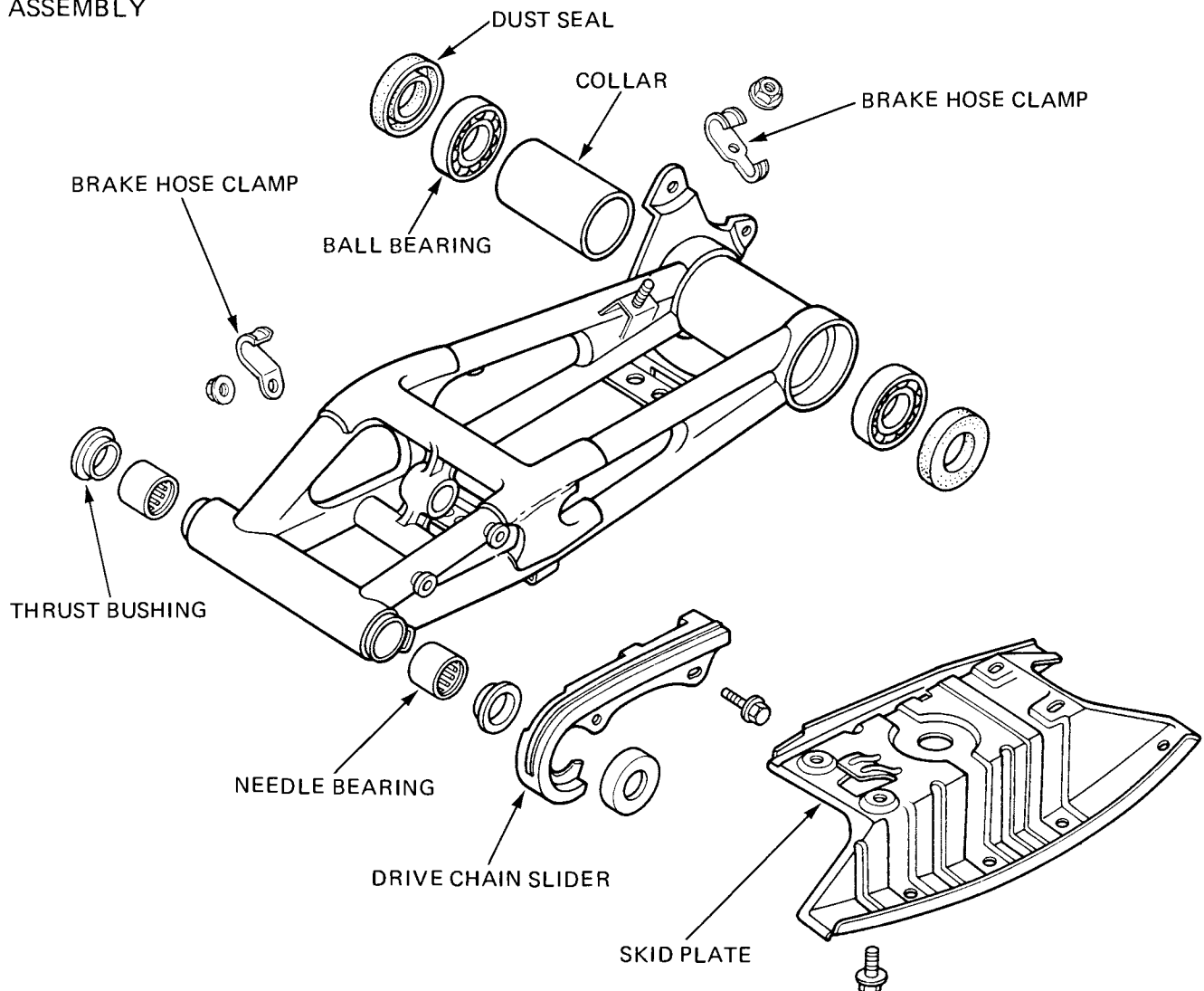

REAR SUSPENSION

After 1983

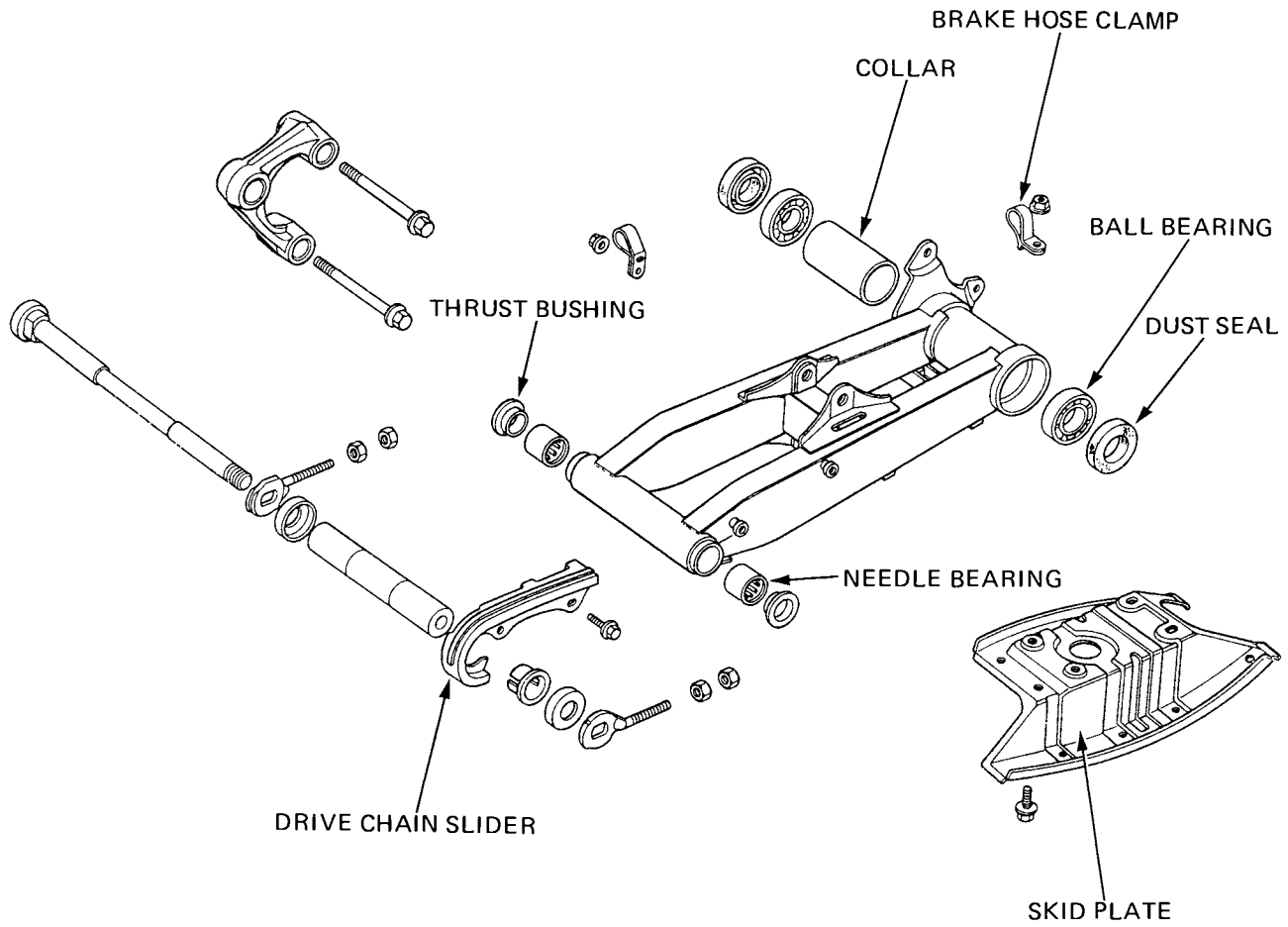

Drive in the axle shaft ball bearing.
 Slide the collar into the swingarm from the opposite side.
 Drive in the ball bearing on the opposite side.

Install the dust seals.

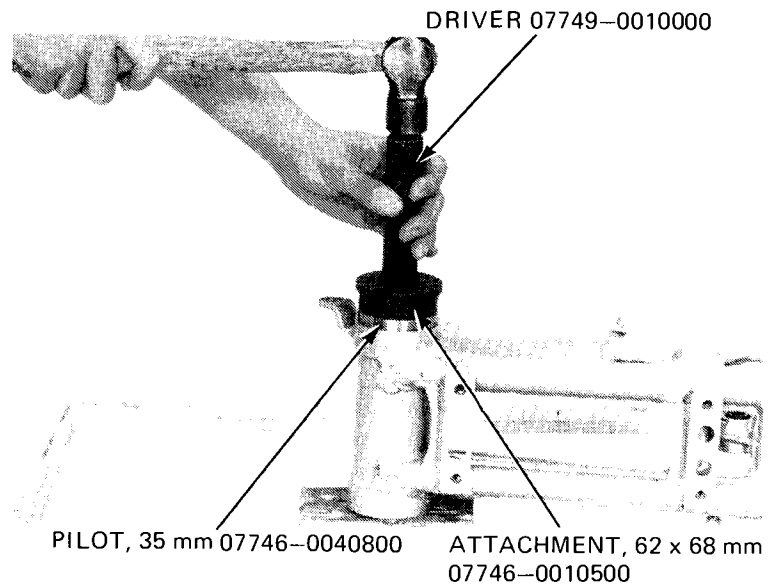

Grease the pivot needle bearings.
 Drive in the swingarm pivot needle bearing until the attachment contacts the swingarm.

NOTE:

Bearing manufacturer's mark should face out.

Align the thrust bushing with the installed needle bearing. Drive in the thrust bushing with the same special tools until the bushing shoulder comes in contact with the swingarm.
 Repeat this procedure for the opposite side.

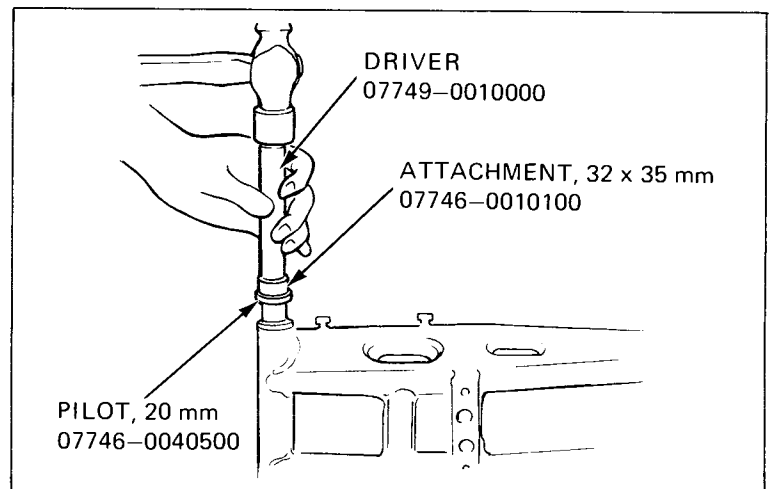

INSTALLATION

Place the swingarm into the frame and install the pivot bolt. Install the nut and torque it.

TORQUE:

70–110 N·m (7.0–11.0 kg·m, 51–80 ft·lb)

Install the rear shock absorber lower mount bolt.

TORQUE:

30–40 N·m (3.0–4.0 kg·m, 22–29 ft·lb)

Install the brake hose clamps.

Install the rear axle shaft (page 12-5).

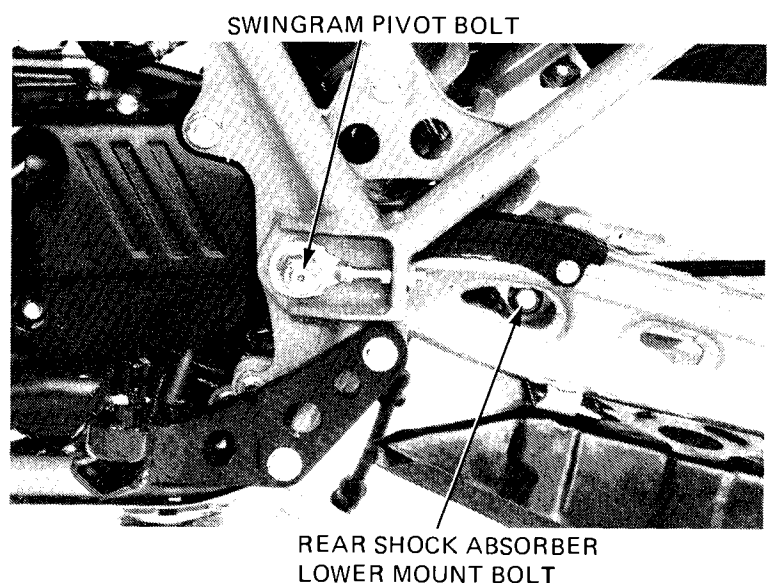

BRAKE MECHANISM

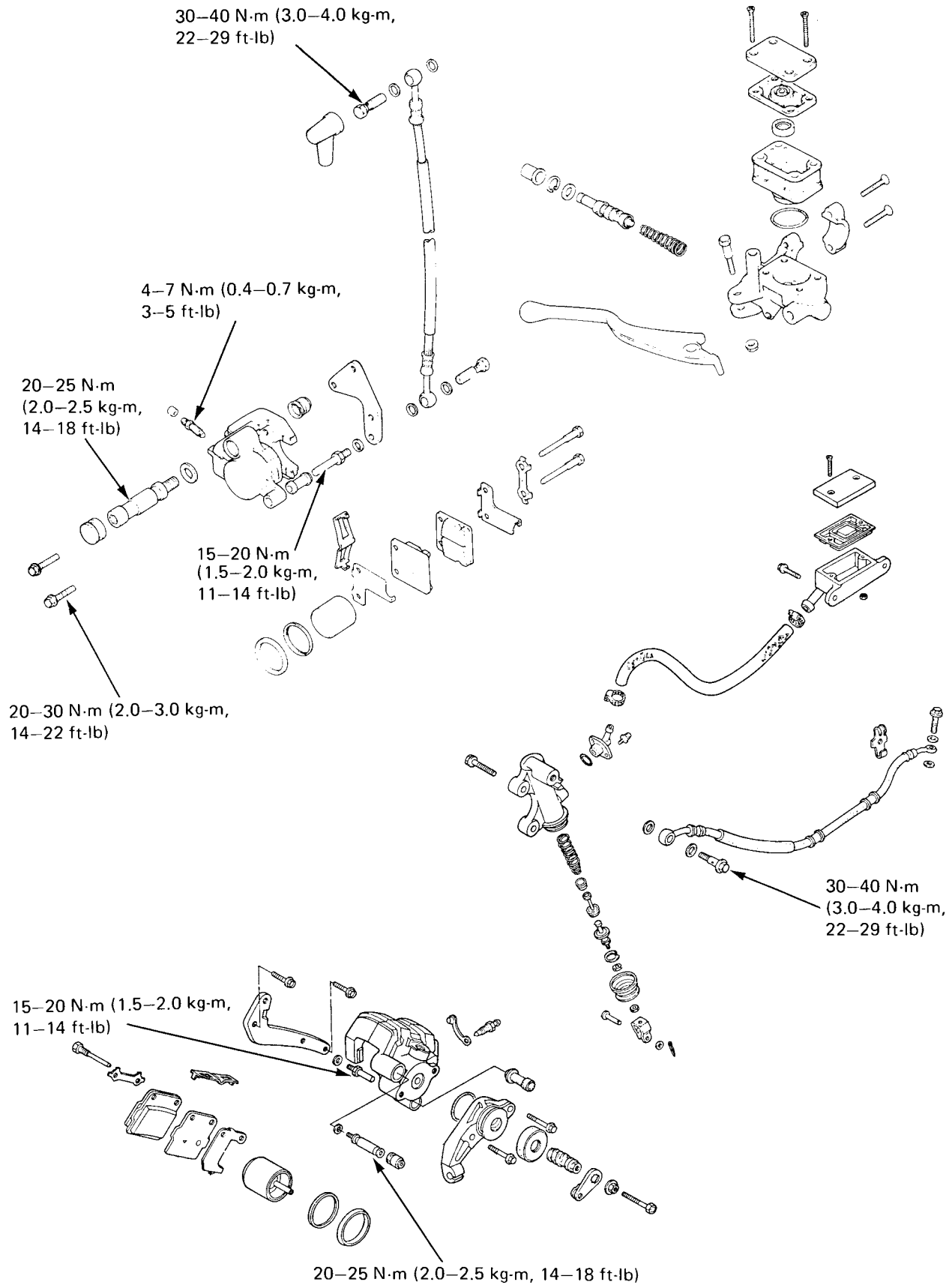

14. BRAKE MECHANISM

SERVICE INFORMATION	14-1
TROUBLESHOOTING	14-2
BRAKE FLUID REPLACEMENT/AIR BLEEDING	14-3
BRAKE PADS/DISC	14-5
FRONT MASTER CYLINDER	14-7
BRAKE CALIPER	14-10
REAR MASTER CYLINDER	14-17

SERVICE INFORMATION

GENERAL

- The front and rear brakes can be removed without disconnecting the hydraulic system.
- Once the hydraulic systems have been opened, or if the brakes feel spongy, the system must be bled.
- Do not allow foreign material to enter the system when filling the reservoir.
- Avoid spilling brake fluid on painted surfaces or instrument lenses, as severe damage will result.
- Always check brake operation before riding the ATC.

SPECIFICATIONS

ITEM	STANDARD	SERVICE LIMIT
Front disc thickness	3.8–4.2 mm (0.150–0.165 in)	3.00 mm (0.118 in)
Front disc runout	0–0.15 mm (0–0.006 in)	0.30 mm (0.012 in)
Front master cylinder I.D.	12.700–12.743 mm (0.5000–0.5017 in)	12.755 mm (0.5022 in)
Front master piston O.D.	12.657–12.684 mm (0.4983–0.4994 in)	12.645 mm (0.4979 in)
Front caliper piston O.D.	33.878–33.928 mm (1.3338–1.3357 in)	33.870 mm (1.3335 in)
Front caliper cylinder I.D.	33.960–34.010 mm (1.3370–1.3390 in)	34.020 mm (1.3394 in)
Rear master cylinder I.D.	14.000–14.043 mm (0.5512–0.5529 in)	14.055 mm (0.5533 in)
Rear master piston O.D.	13.957–13.984 mm (0.5495–0.5506 in)	13.954 mm (0.5490 in)
Rear caliper cylinder I.D.	33.960–34.010 mm (1.3370–1.3390 in)	34.020 mm (1.3394 in)
Rear caliper piston O.D.	33.878–33.928 mm (1.3338–1.3357 in)	33.870 mm (1.3335 in)
Rear disc thickness	3.8–4.2 mm (0.150–0.165 in)	3.00 mm (0.118 in)
Rear disc runout	0–0.15 mm (0–0.006 in)	0.30 mm (0.012 in)

14

TOOL

Special

Snap ring pliers

07914–3230001

TROUBLESHOOTING

Brake Lever/Pedal Soft or Spongy

1. Air bubbles in hydraulic system.
2. Low fluid level.
3. Hydraulic system leaking.

Brake Lever/Pedal Too Hard

1. Sticking piston.
2. Clogged hydraulic system.
3. Pads glazed or worn excessively.

Brakes Drag

1. Hydraulic system sticking.
2. Incorrect adjustment of lever or pedal.
3. Sticking piston.

Brakes Grab or Pull to One Side

1. Pads contaminated.
2. Disc or wheel misaligned.

Brakes Chatter or Squeal

1. Pads contaminated.
2. Excessive disc runout.
3. Caliper installed incorrectly.
4. Disc or wheel misaligned.

BRAKE FLUID REPLACEMENT/ AIR BLEEDING

Check the fluid level with the fluid reservoir parallel to the ground.

CAUTION:

- *Install the diaphragm on the reservoir when operating the brake lever or pedal. Failure to do so will allow brake fluid to squirt out of the reservoir during brake operation.*
- *Avoid spilling fluid on painted surfaces. Place clean shop towels over the fuel tank whenever the system is serviced.*

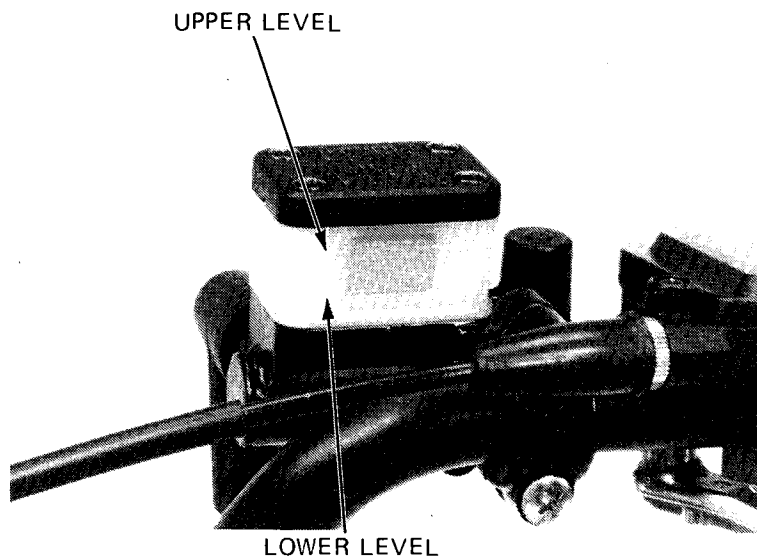

BRAKE FLUID DRAINING

Connect a bleed hose to the bleed valve. Loosen the caliper bleed valve and pump the brake lever or pedal. Stop operating the lever or pedal when fluid stops flowing out of the bleed valve.

WARNING

A contaminated brake disc or pad reduces stopping power. Discard contaminated pads and clean a contaminated disc with a high quality brake degreasing agent.

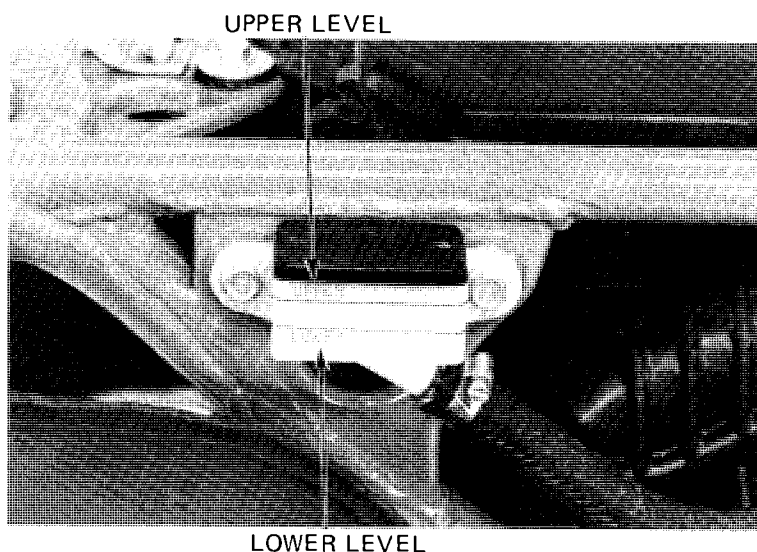

BRAKE FLUID FILLING

NOTE:

Do not mix different types of fluid since they are not compatible.

Close the bleed valve, fill the reservoir, and install the diaphragm.

To prevent piston overtravel and brake fluid seepage, keep a 20 mm (3/4 in) spacer between the handlebar grip and lever when bleeding the front brake system. When bleeding the rear brake system depress the pedal only as far as its normal travel. Pump up the system pressure with the lever until there are no air bubbles in the fluid flowing out of the reservoir small hole and lever or pedal resistance is felt.

BRAKE MECHANISM

AIR BLEEDING

NOTE:

- Check the fluid level often while bleeding the brakes to prevent air from being pumped into the system.
- Use only **DOT 3 brake fluid** from a sealed container.
- Do not mix brake fluid types and never reuse the contaminated fluid which has been pumped out during brake bleeding, because this will impair the efficiency of the brake system.
- When using the Mityvac Brake Bleeder, follow the manufacturer's instructions.

Pump the brake lever or pedal to bring the caliper pads in contact with the disc.

Remove the master cylinder cap and fill the reservoir to near full.

Connect the Mityvac Brake Bleeder or equivalent to the bleeder valve.

Pump the brake bleeder and loosen the bleeder valve.

Add fluid when the fluid level in the master cylinder reservoir is low.

Repeat above procedures until air bubbles do not appear in the plastic hose.

NOTE:

If air is entering the bleeder from around the bleeder valve threads, seal the threads with teflon tape.

If a Mityvac Brake Bleeder or equivalent not available, bleed the system as follows:

- 1) Connect the bleeder tube to the bleeder valve.
- 2) Squeeze the brake lever, open the bleed valve 1/2 turn and then close the valve.

NOTE:

Do not release the brake lever until the bleed valve has been closed.

- 3) Release the brake lever slowly and wait several seconds after it reaches the end of its travel.

Repeat steps 1 and 2 until bubbles cease to appear in the fluid at the end of the hose.

Fill the fluid reservoir to the upper level mark.

WARNING

A contaminated brake disc or pad reduces stopping power. Discard contaminated pads and clean a contaminated disc with a high quality brake degreasing agent.

MITYVAC BRAKE BLEEDER
#6860-Commercially Available

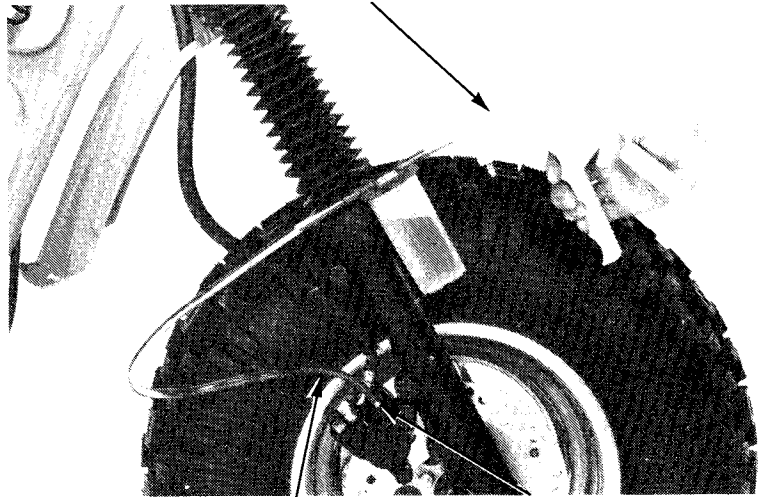

RUBBER HOSE BLEEDER VALVE

MITYVAC BRAKE BLEEDER
#6860-Commercially Available

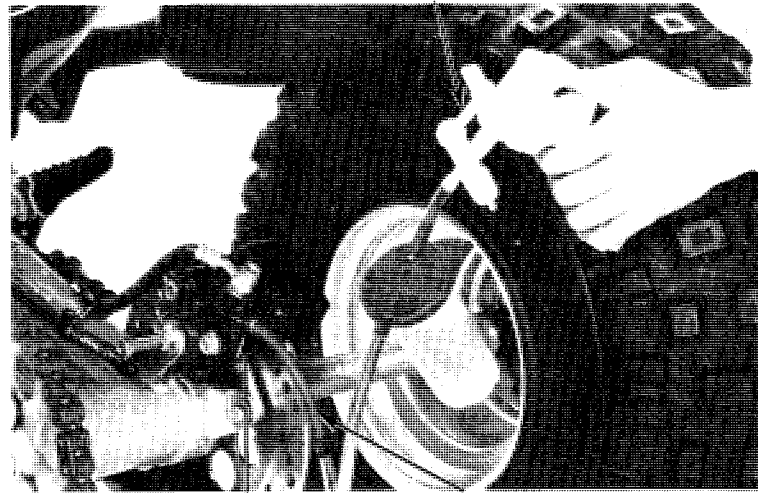

BLEEDER VALVE RUBBER HOSE

BRAKE PADS/DISC

FRONT PAD REPLACEMENT

Remove the wheel nuts.

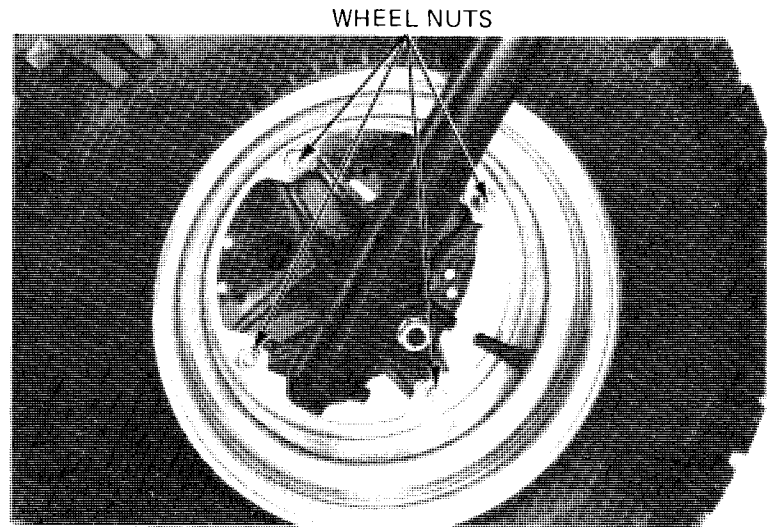

NOTE:

Do not disconnect the brake hose when replacing the brake pads.

Remove the two caliper bolts.
Slide the wheel away from the brake disc to get the space to remove the caliper.
Remove the caliper from the fork leg.

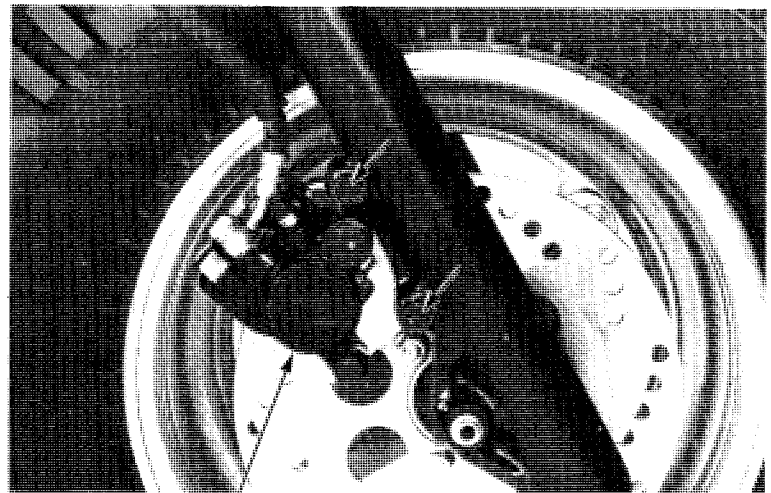

Bend up the tabs of the lock washer and loosen the two pad pin bolts.

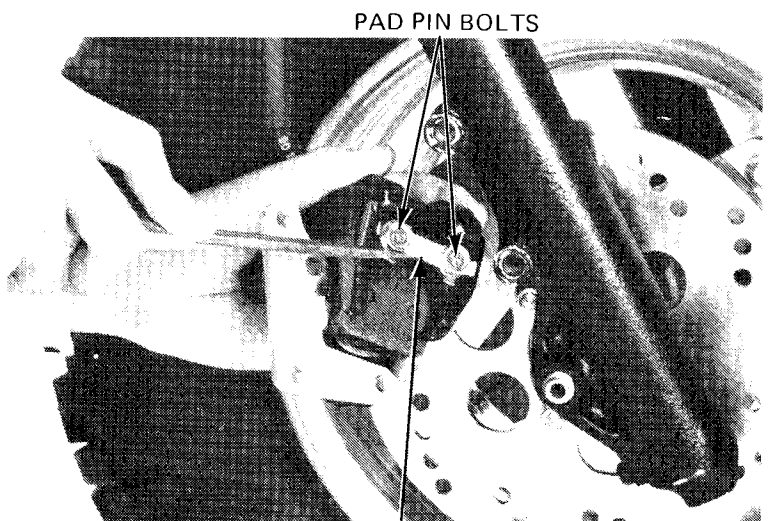

BRAKE MECHANISM

Remove the pad pin bolts and brake pads.

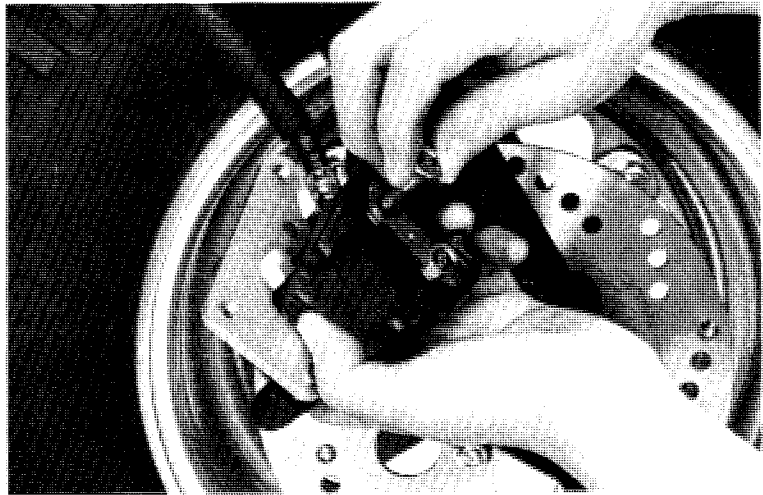

Clean the brake caliper.
Position the pad spring in the caliper as shown.
Push the caliper piston in all the way.
Install new pads and the shim in the caliper.
Push the pads against the caliper to depress the pad spring and loosely install the pad pin bolts with a new lock washer.
Tighten the pad pin bolts.
Bend the tabs of the lock washer up.

PAD SPRING

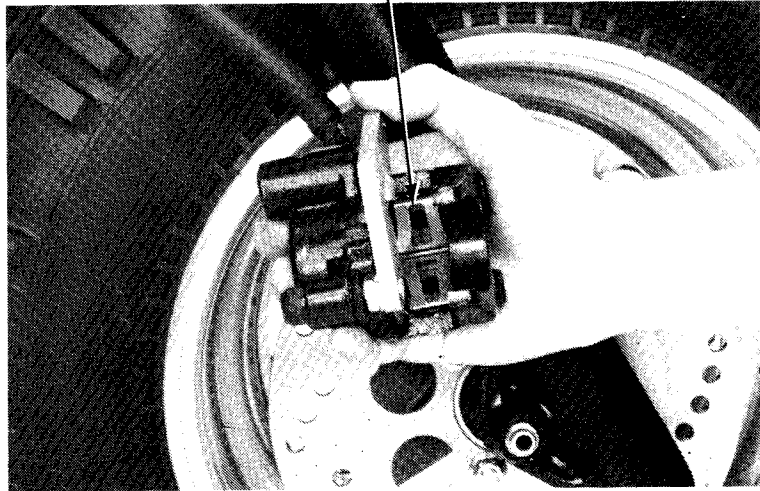

Install the caliper to the fork leg so the brake disc is positioned between the pads, making sure not to damage the pads.
Tighten the caliper bolts.

TORQUE: 20–30 N·m (2.0–3.0 kg·m, 14–22 ft·lb)

Install the four wheel nuts.

TORQUE: 30–40 N·m (3.0–4.0 kg·m, 22–29 ft·lb)

CALIPER BOLTS

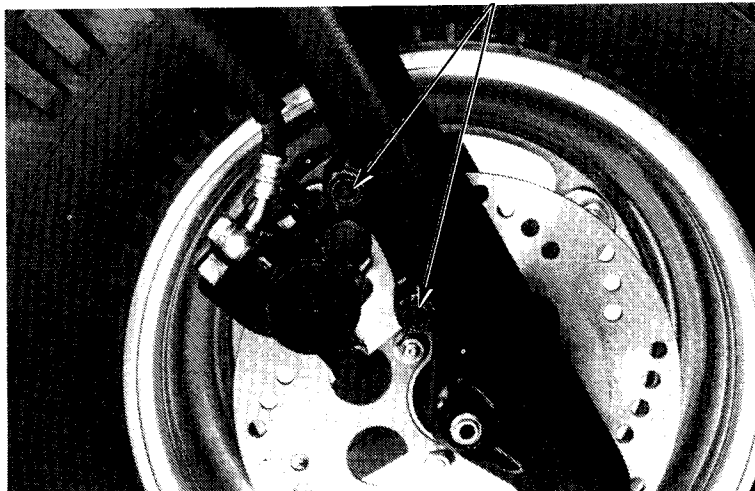

REAR PAD REPLACEMENT

Remove the rear caliper mount bolts and remove the rear caliper from the swingarm.

Replace the rear brake pads using the same method as used for front brake pad replacement (page 14-5).

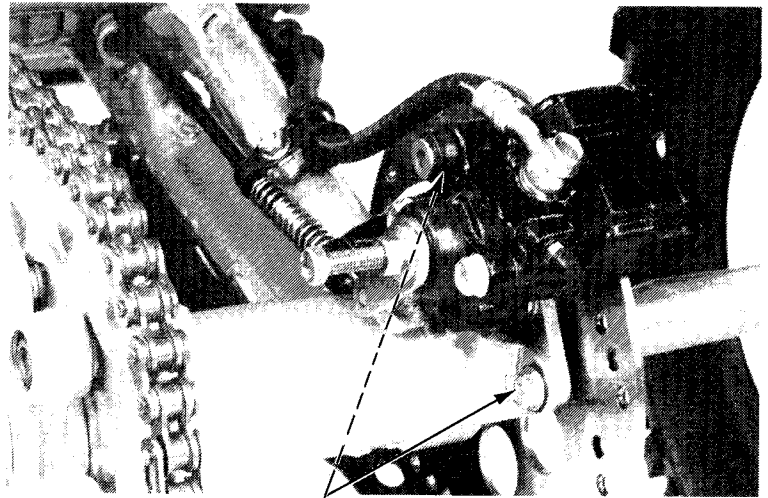

REAR CALIPER MOUNT BOLTS
20–30 N·m (2.0–3.0 kg·m, 14–22 ft·lb)

DISC THICKNESS

Measure the disc thickness with a micrometer.

SERVICE LIMIT:

FRONT/REAR: 3.00 mm (0.118 in)

DISC WARPAGE

Remove the disc from the wheel.

Measure the disc warpage on a surface plate with a feeler gauge.

SERVICE LIMIT:

FRONT/REAR: 0.3 mm (0.012 in)

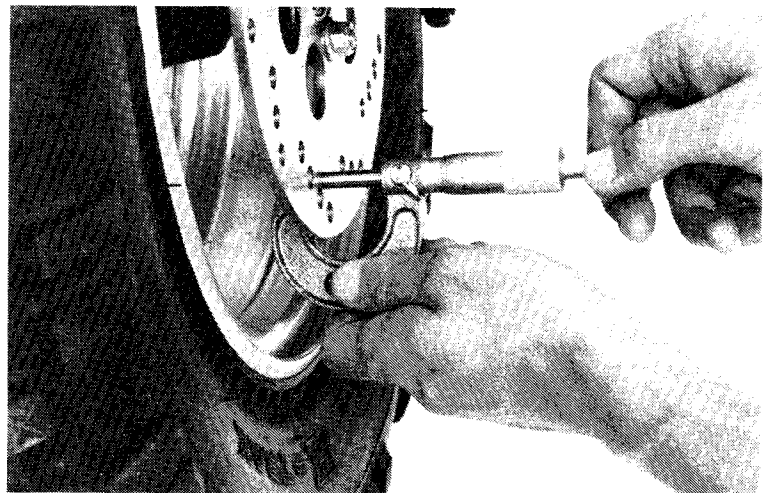

FRONT MASTER CYLINDER

DISASSEMBLY

Drain the brake fluid from the hydraulic system.

Remove the brake lever from the master cylinder. Disconnect the brake hose from the master cylinder.

CAUTION:

Avoid spilling brake fluid on painted surface. Place clean shop towels over the fuel tank whenever the brake system is serviced.

NOTE:

When removing the brake hose bolt, cover the end of the hose to prevent contamination and secure the hose.

Remove the two screws and the master cylinder.

BRAKE HOSE BOLT

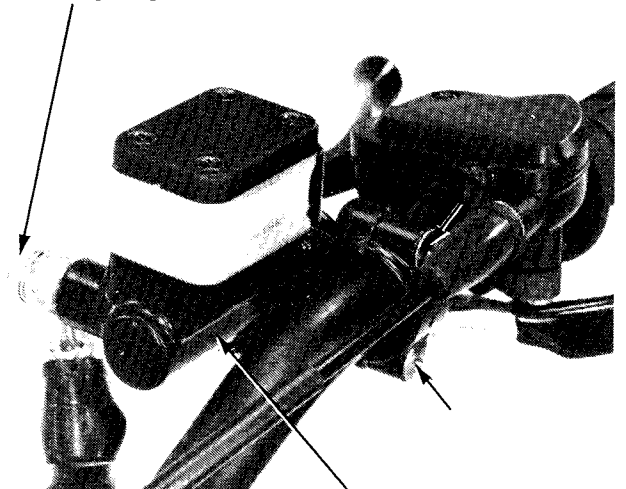

FRONT MASTER CYLINDER

BRAKE MECHANISM

Remove the reservoir cap and diaphragm.
Remove the boot.
Remove the snap ring.

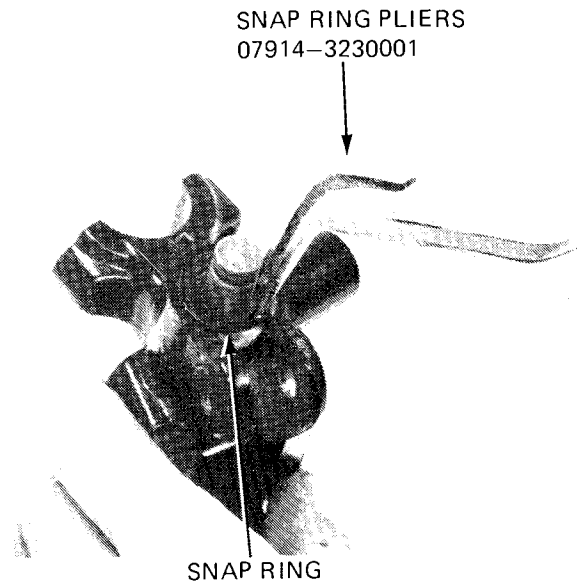

Remove the stopper plate, master cylinder piston and spring.

Remove the reservoir from the master cylinder.

Clean the master cylinder and reservoir in clean brake fluid.

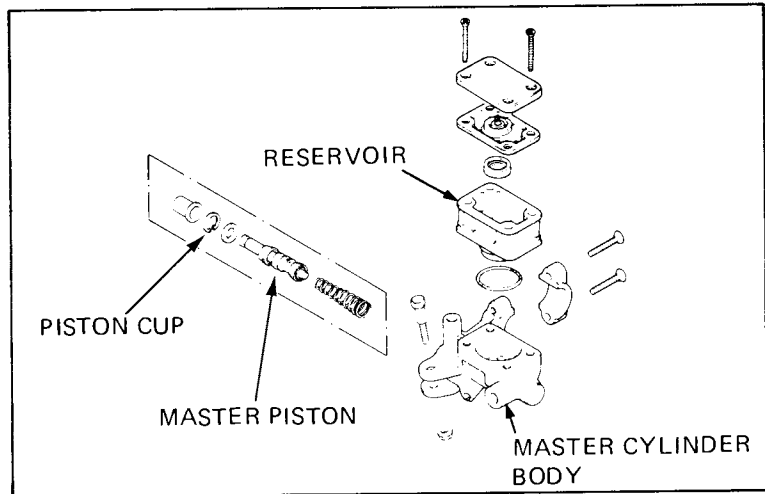

MASTER CYLINDER INSPECTION

Check the master cylinder for score marks, scratches or other damage.

Measure the master cylinder I.D.

SERVICE LIMIT: 12.755 mm (0.5022 in)

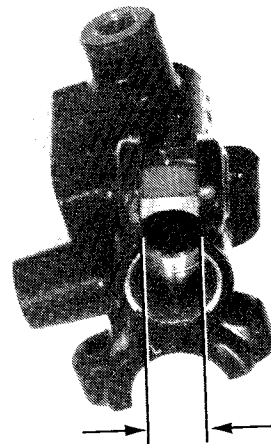

MASTER PISTON INSPECTION

Check the master piston for score marks, scratches or other damage.

Measure the master piston O.D.

SERVICE LIMIT: 12.645 mm (0.4979 in)

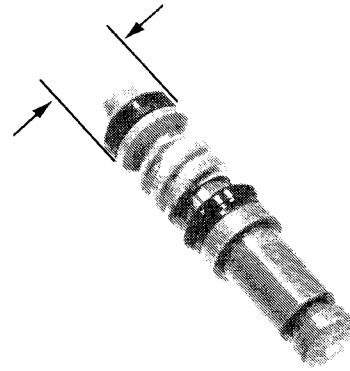

MASTER CYLINDER ASSEMBLY

Install the O-ring in the groove in the reservoir.

Clean the mating faces of the master cylinder body and reservoir and coat the surfaces with a small amount of adhesive (Three-bond No. 1211 or equivalent).

Apply silicone grease to the piston cup and pour a small amount of brake fluid into the cylinder.

NOTE:

- Replace the master piston and spring as a set. Do not replace one without replacing the other.
- Check that the snap ring is seated in the groove.

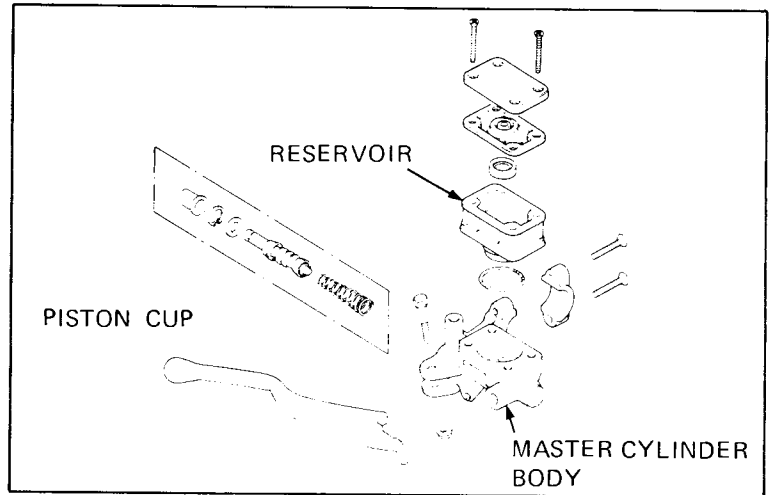

Install the boot.

Place the master cylinder on the handlebar and install the holder and the two mounting screws. Align the end of the holder with the punch mark on the handlebar, and tighten the upper screw first, then tighten the lower screw.

Connect the brake hose with the bolt and its sealing washers. Tighten the brake hose bolt.

TORQUE: 30–40 N·m (3.0–4.0 kg·m, 22–29 ft·lb)

Fill the reservoir and bleed the system (page 14-3).

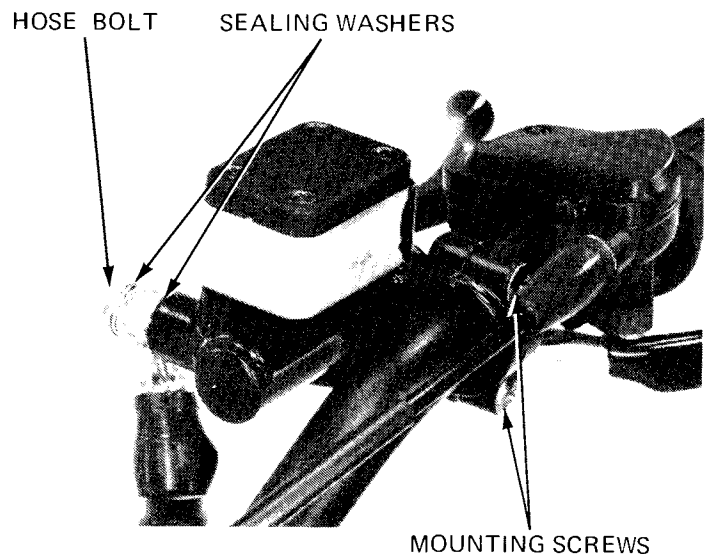

BRAKE MECHANISM

BRAKE CALIPER

FRONT BRAKE CALIPER REMOVAL

Place a clean drain pan under the caliper and disconnect the brake hose from the caliper.

CAUTION:

Avoid spilling brake fluid on painted surfaces to prevent paint damage.

Remove the caliper mount bolts.

Remove the four wheel nuts and move the front wheel to get enough space to remove the caliper.

Remove the caliper.

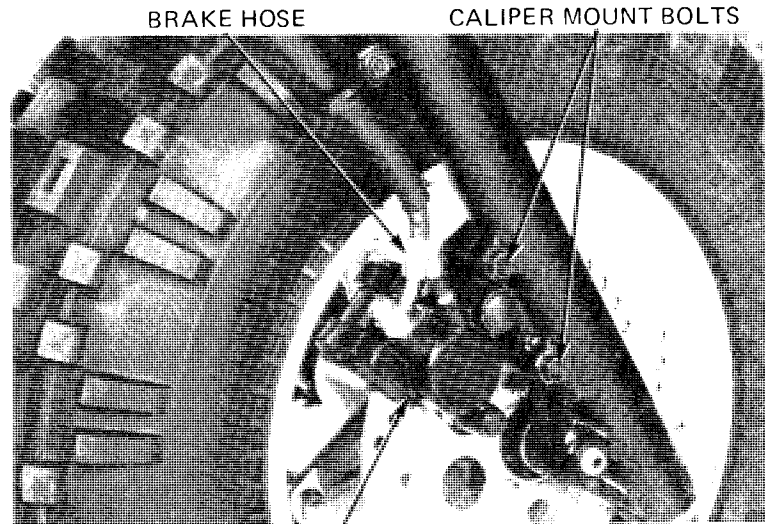

FRONT BRAKE CALIPER

REAR BRAKE CALIPER REMOVAL

Loosen the lock nut and remove the parking brake adjusting bolt.

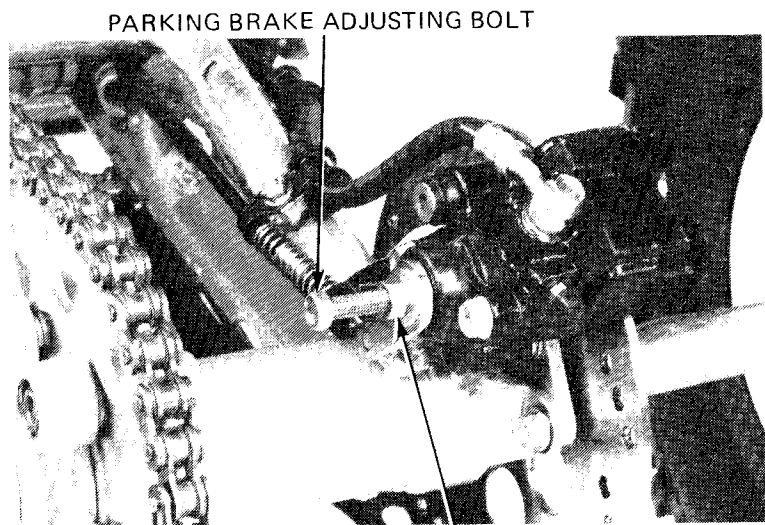

LOCK NUT

Remove the parking brake arm and cable from the caliper.

Place a clean drain pan under the caliper and disconnect the brake hose from the caliper.

Remove the rear brake caliper mount bolts and caliper from the swingarm.

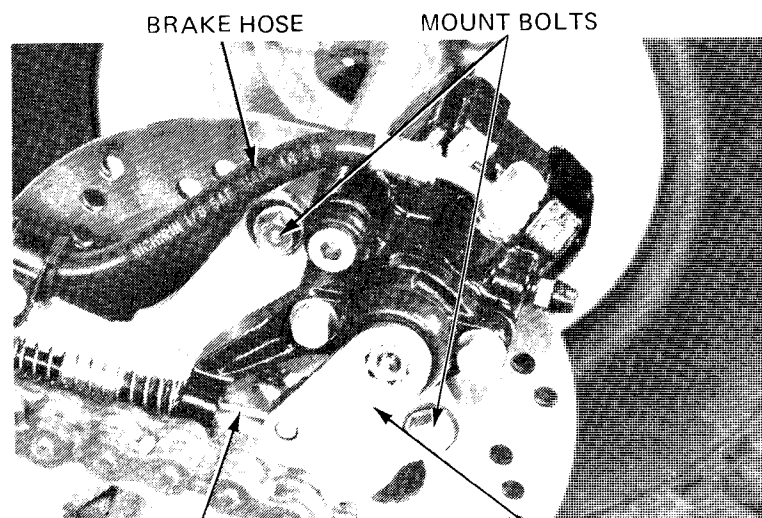

PARKING BRAKE CABLE

PARKING BRAKE ARM

CALIPER DISASSEMBLY

On the front caliper, remove the rubber cap on the socket bolt.

Remove the socket bolt and washer and remove the caliper bracket from the caliper.

Remove the rubber boots from the caliper.

Remove the brake pads (page 14-5).

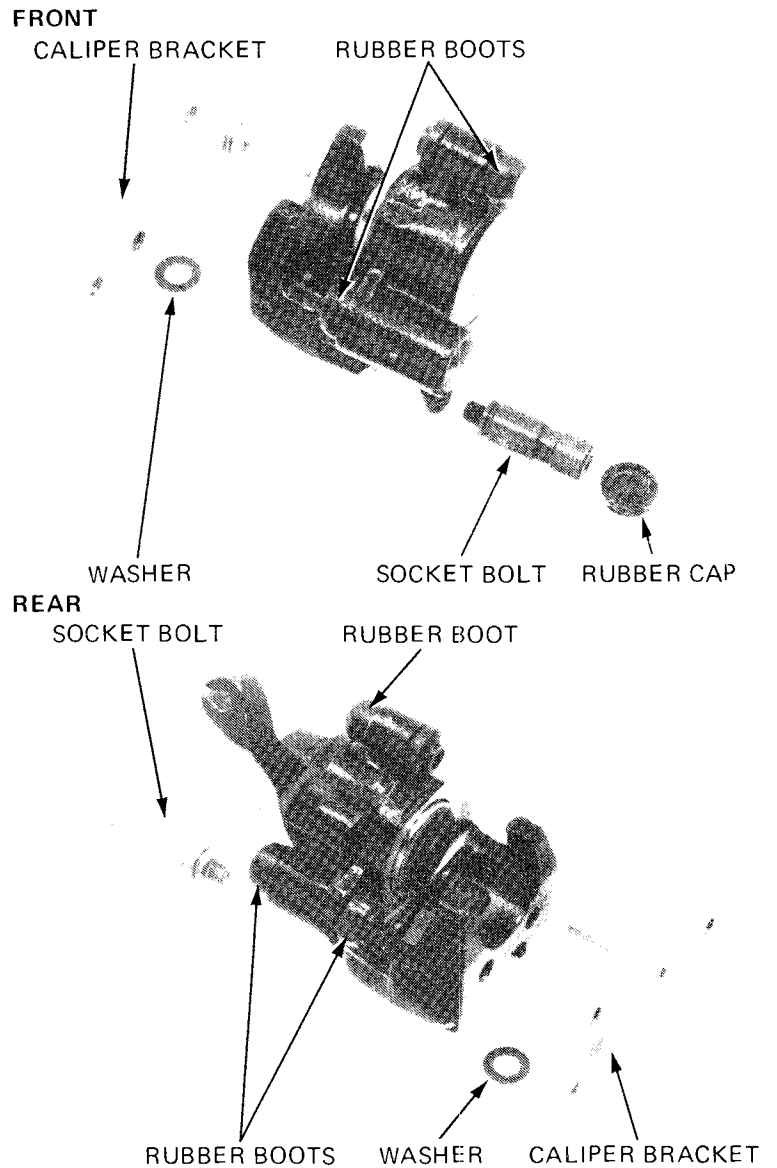

Position the caliper with the piston down and apply small squirts of air pressure to the fluid inlet to remove the piston.

WARNING

- Do not use high pressure air or bring the nozzle too close to the inlet.
- Place a shop towel over the piston to prevent the piston from becoming a projectile.

Examine the piston and cylinder for scoring, scratches or other damage and replace if necessary.

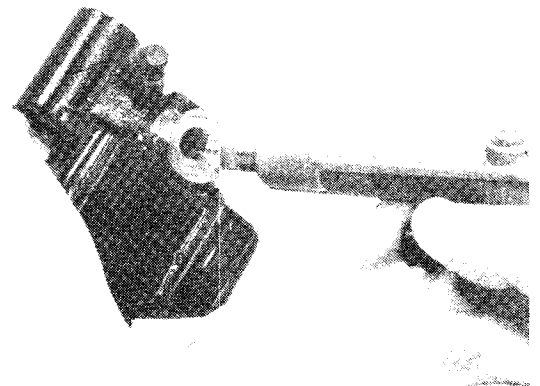

BRAKE MECHANISM

Push the oil seals in and then lift them out. Clean the oil seal grooves with brake fluid.

CAUTION:

Be careful not to damage the piston sliding surface.

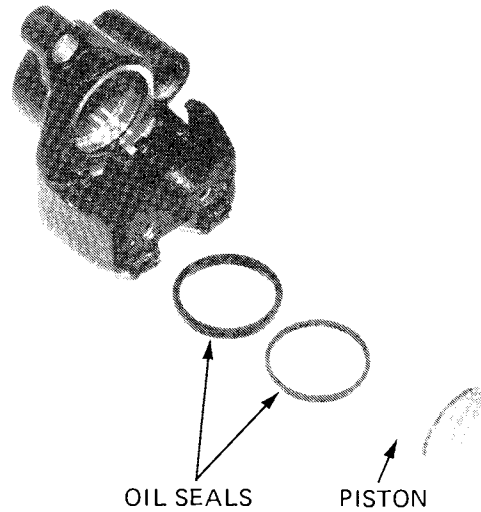

CALIPER CYLINDER INSPECTION

Check the caliper cylinder for scoring, scratches or other damage.

Measure the caliper cylinder I.D.

SERVICE LIMIT: 34.020 mm (1.3394 in)

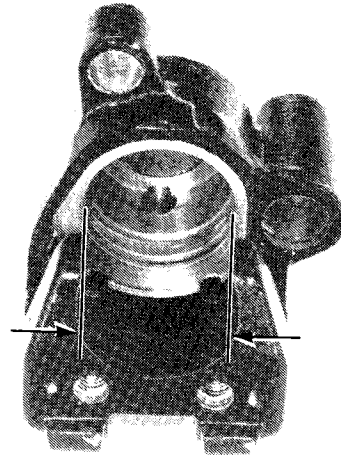

CALIPER PISTON INSPECTION

Check the piston for scoring, scratches or other damage.

Measure the caliper piston O.D.

SERVICE LIMIT: 33.870 mm (1.3335 in)

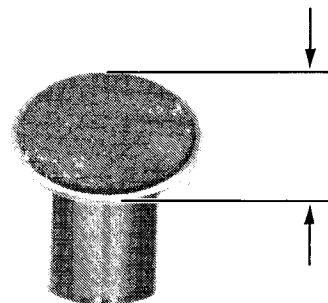

CALIPER ASSEMBLY

Lubricate the inside diameter of the caliper cylinder with brake fluid.

Install new oil seals.

BRAKE FLUID

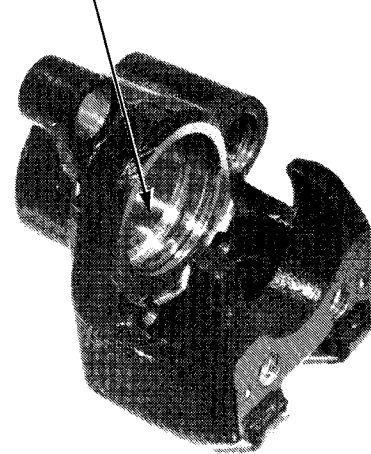

Install the piston with the piston pad end facing the brake pad side.

NOTE:

Install the piston with the end projecting about 10 mm (3/8 in) from the caliper cylinder.

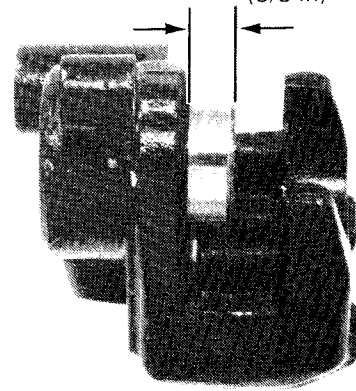
10 mm
(3/8 in)

Install the brake pads (page 14-6).

Install the pin boots in the caliper and lubricate the inside with silicone grease.

WARNING

Do not allow grease to touch the pads, or stopping power will be reduced.

Install the caliper bracket with the washer and socket bolt.

Tighten the socket bolt.

TORQUE: 20–25 N·m (2.0–2.5 kg·m, 14–18 ft·lb)

On the front caliper, install the rubber cap on the socket bolt.

SOCKET BOLT

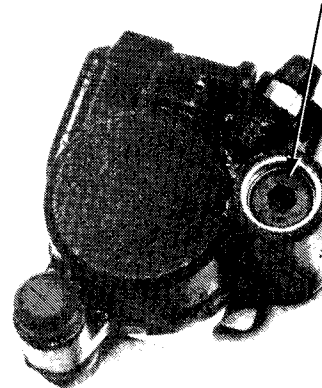

BRAKE MECHANISM

PARKING BRAKE REMOVAL

Remove the bolts and parking brake assembly.

PARKING BRAKE ASSEMBLY

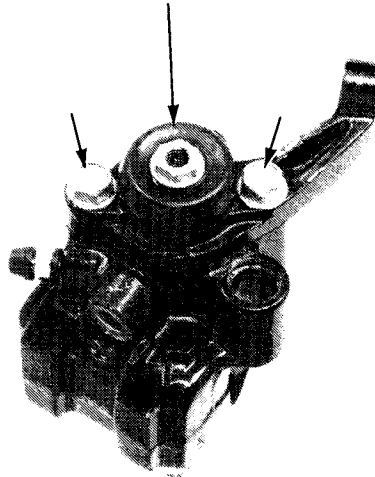

Remove the boot and parking brake shaft.

BOOT SHAFT

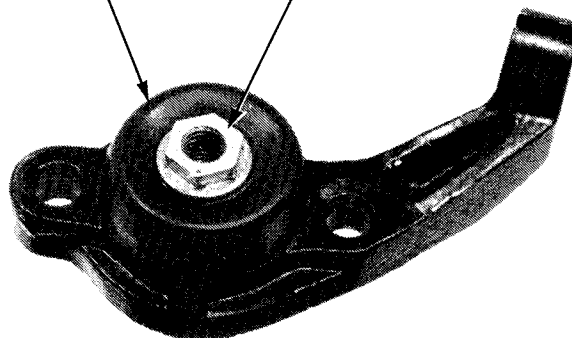

INSPECTION

Check the parking brake shaft for wear or damage.

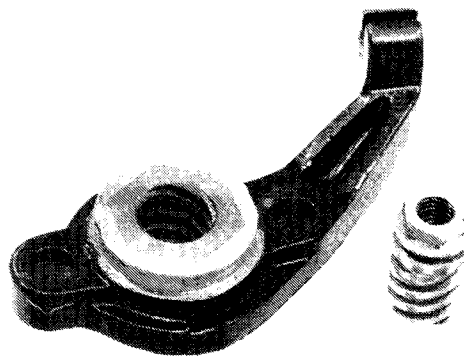

ASSEMBLY

Apply grease to the parking brake shaft, position the shaft so that the punch mark is within the index marks on the parking brake assembly and thread the shaft into the parking brake assembly.

Install a new O-ring on the parking brake assembly.

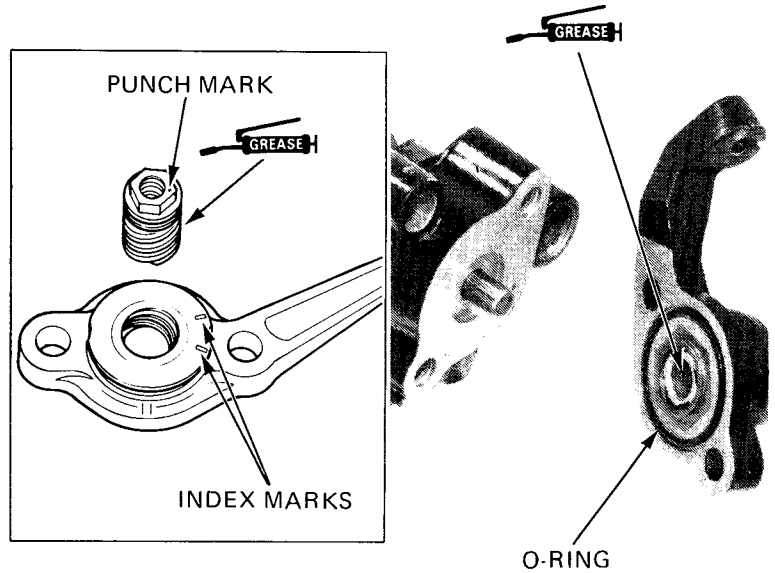

Install the parking brake assembly on the brake caliper. Install the bolts and tighten to the specified torque.

TORQUE: 20–25 N·m (2.0–2.5 kg·m, 14–18 ft·lb)

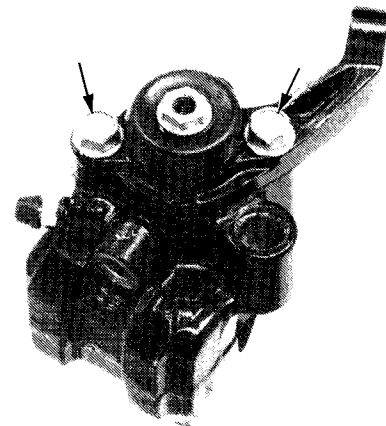

FRONT CALIPER INSTALLATION

Install the caliper assembly over the disc so the disc is positioned between the pads, being careful not to damage the pads.

Install and tighten the caliper mount bolts.

TORQUE: 20–30 N·m (2.0–3.0 kg·m, 14–22 ft·lb)

Install and tighten the four wheel nuts.

TORQUE: 30–40 N·m (3.0–4.0 kg·m, 22–29 ft·lb)

Connect the brake hose to the caliper with the bolt and sealing washers. Tighten the bolt.

TORQUE: 30–40 N·m (3.0–4.0 kg·m, 22–29 ft·lb)

Fill the brake fluid reservoir and bleed the front brake system.

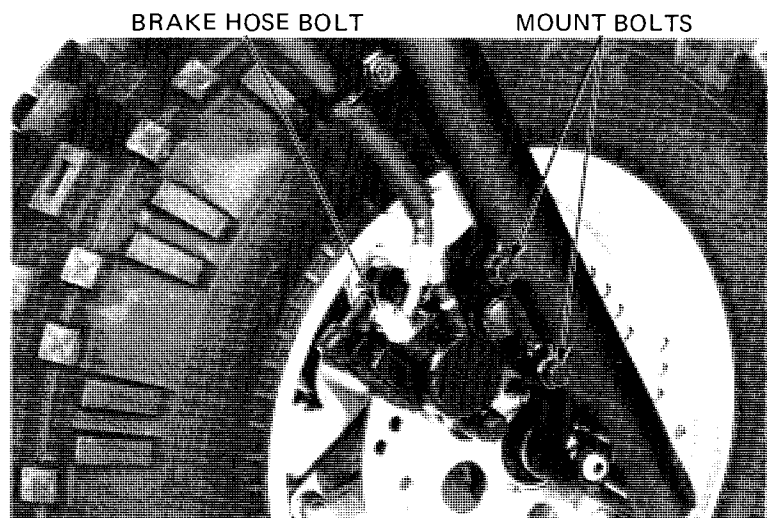

BRAKE MECHANISM

REAR CALIPER INSTALLATION

Install the caliper over the disc so the disc is positioned between the pads, being careful not to damage the pads.

Install and tighten the caliper mount bolts.

TORQUE: 20–30 N·m (2.0–3.0 kg·m, 14–22 ft·lb)

Route the end of the parking brake cable through the parking brake assembly.

Connect the cable end of the parking brake arm.

Align the punch mark on the back of the arm with the punch mark on the shaft of the parking brake assembly, and install the arm onto the shaft.

Install the parking brake adjusting bolt.

Connect the brake hose to the caliper with the bolt and sealing washers. Tighten the bolt.

TORQUE: 30–40 N·m (3.0–4.0 kg·m, 22–29 ft·lb)

Fill the reservoir and bleed the rear brake system (page 14-3).

Adjust the parking brake (page 3-12).

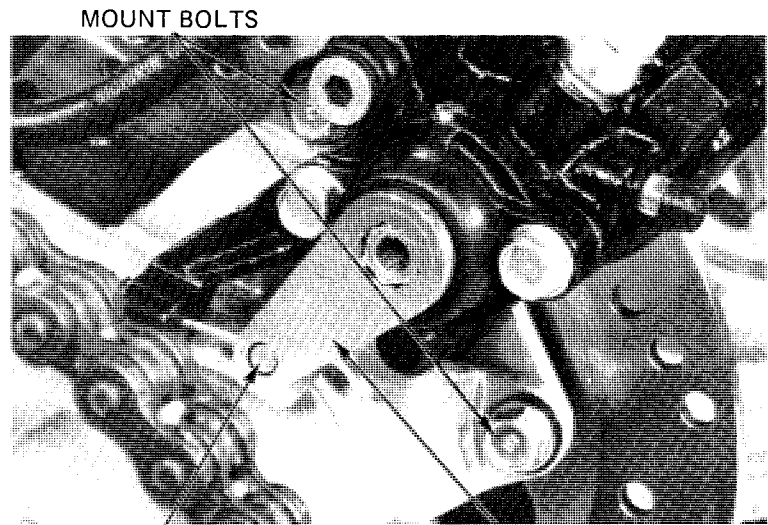

PARKING BRAKE
CABLE END

PARKING BRAKE ARM

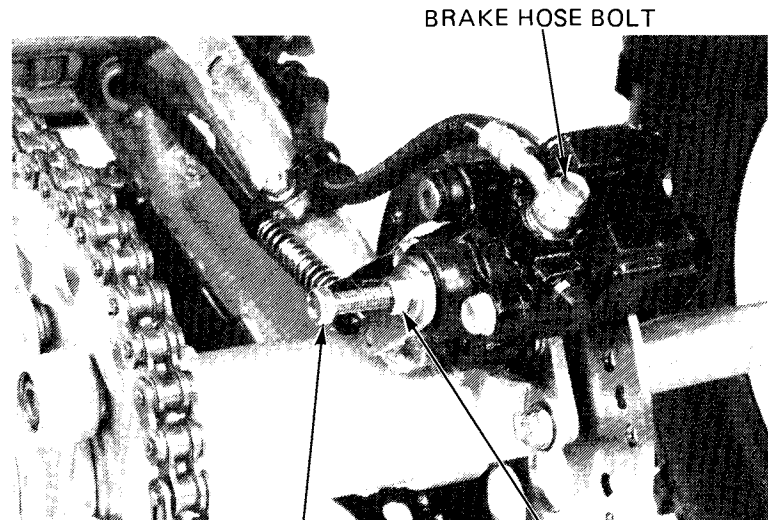

PARKING BRAKE
ADJUSTING BOLT

LOCK NUT

REAR MASTER CYLINDER

REMOVAL

Place a drain pan under the master cylinder and disconnect the brake hoses from the master cylinder.

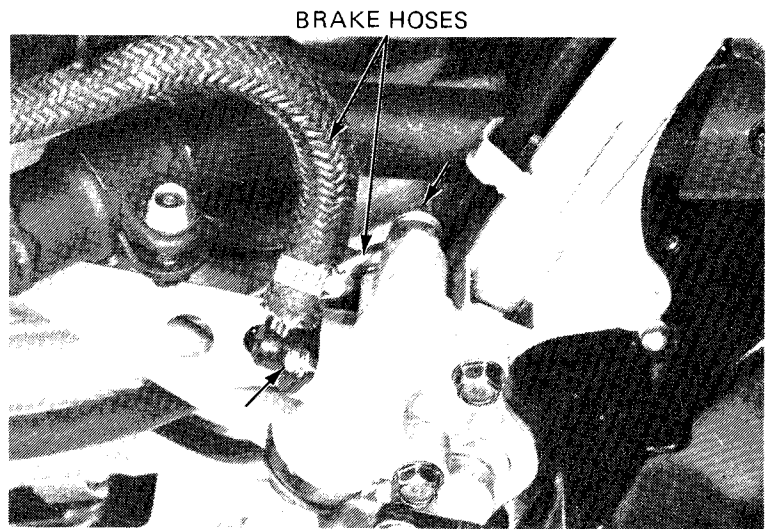

Remove the cotter pin and washer, and pull out the joint pin connecting the master cylinder push rod end and the brake arm.

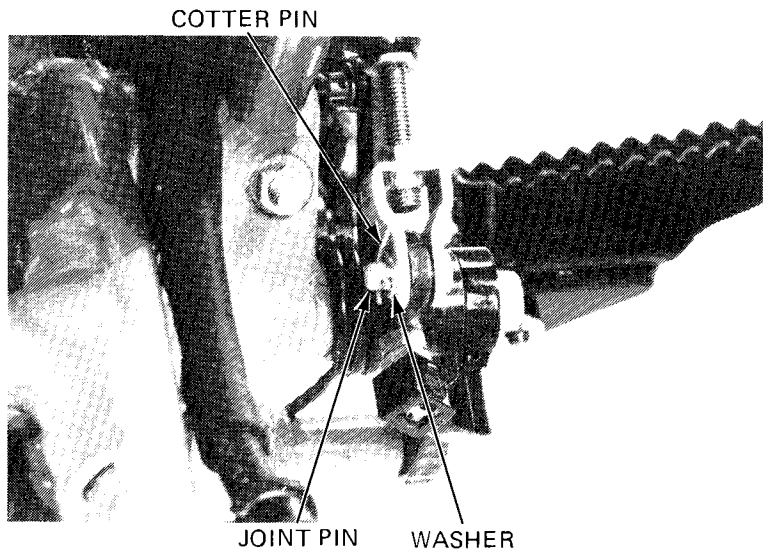

Remove the master cylinder mount bolts and the master cylinder.

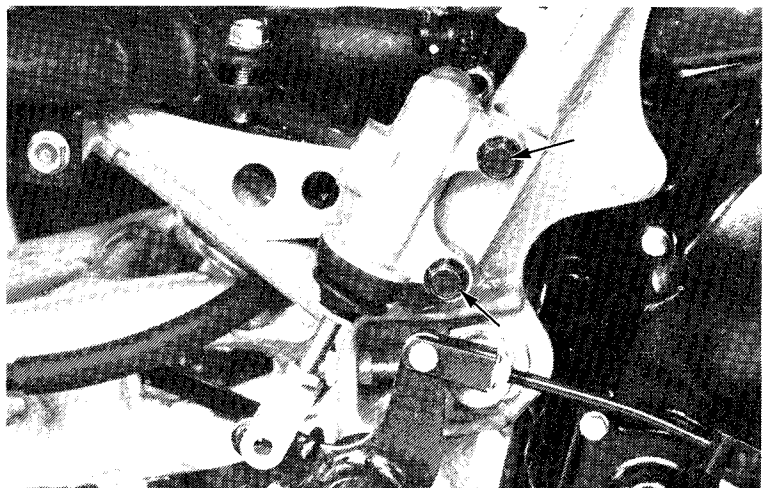

BRAKE MECHANISM

Remove the rubber cover.

Remove the snap ring and push rod from the master cylinder body.

Remove the master piston, primary cup and spring.

It may be necessary to apply a small amount of air pressure to the fluid outlet to remove the master piston and primary cup.

Clean all parts with brake fluid.

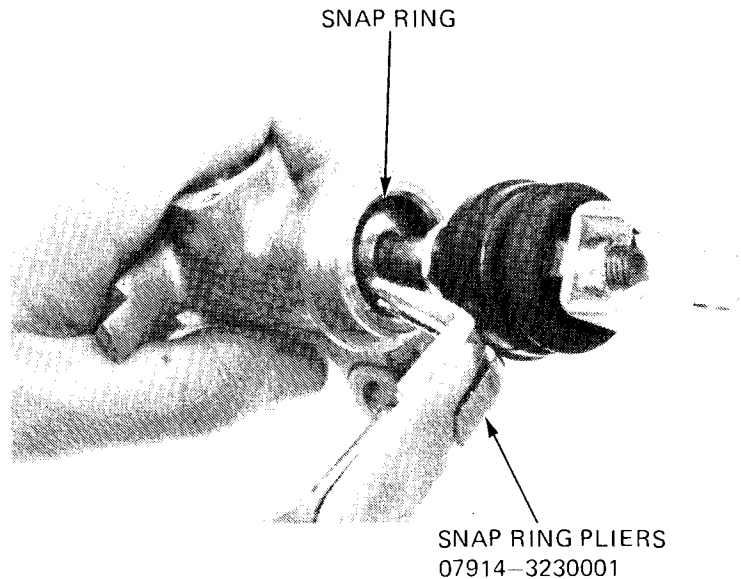

CYLINDER I.D. INSPECTION

Measure the inside diameter of the master cylinder bore.

SERVICE LIMIT: 14.055 mm (0.5533 in)

Check for scores, scratches or nicks.

PISTON O.D. INSPECTION

Measure the master piston O.D.

SERVICE LIMIT: 13.945 mm (0.5490 in)

Check the primary cup and piston cup for damage.

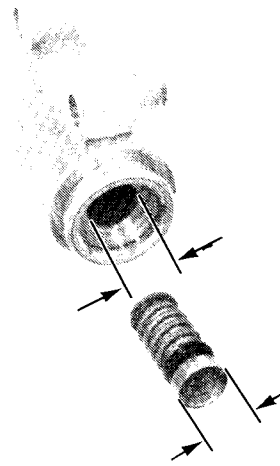

ASSEMBLY

CAUTION:

Handle the master cylinder piston, cylinder and spring as a set.

Assemble the master cylinder.

Coat all parts with clean brake fluid.

Dip the piston cup in brake fluid before assembly.

CAUTION:

When installing the cups, do not allow the lips to turn inside out. Be certain the snap ring is seated firmly in the groove.

Install the primary cup and piston.

Install the push rod and snap ring.

Install the rubber cover.

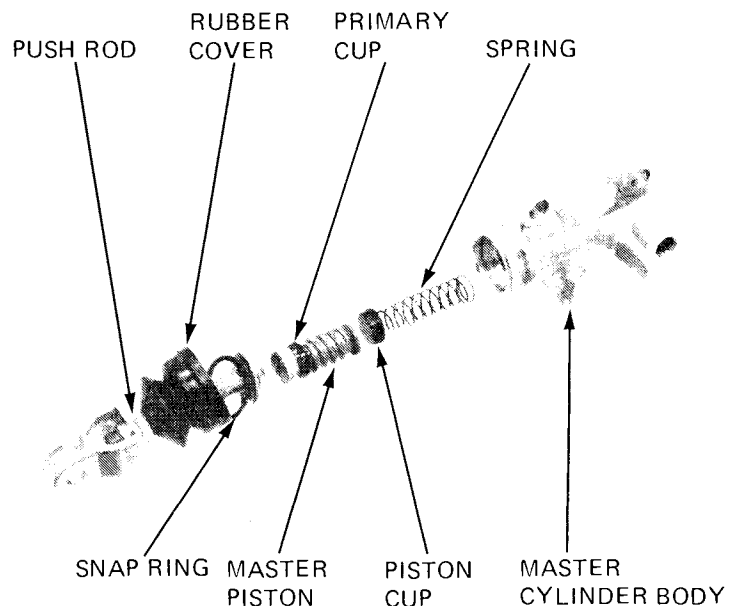

INSTALLATION

Install the rear master cylinder and tighten the mount bolts.

TORQUE: 20–30 N·m (2.0–3.0 kg·m, 14–22 ft·lb)

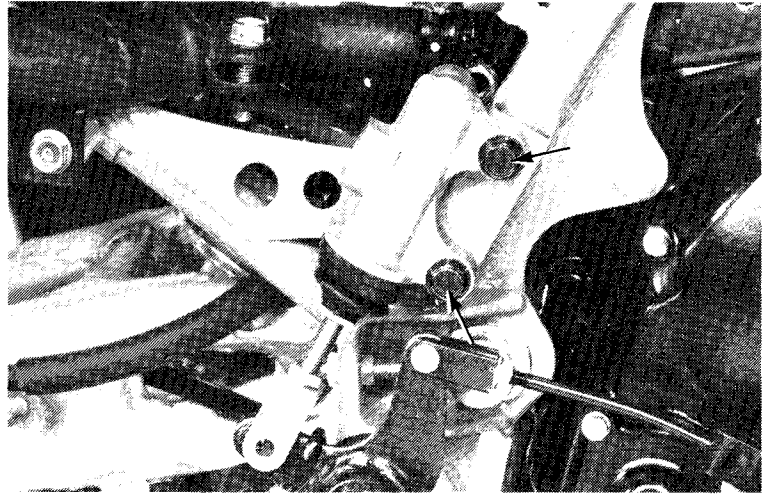

Connect the rear brake arm and master cylinder push rod end with the joint pin. Secure the joint pin with the washer and a new cotter pin.

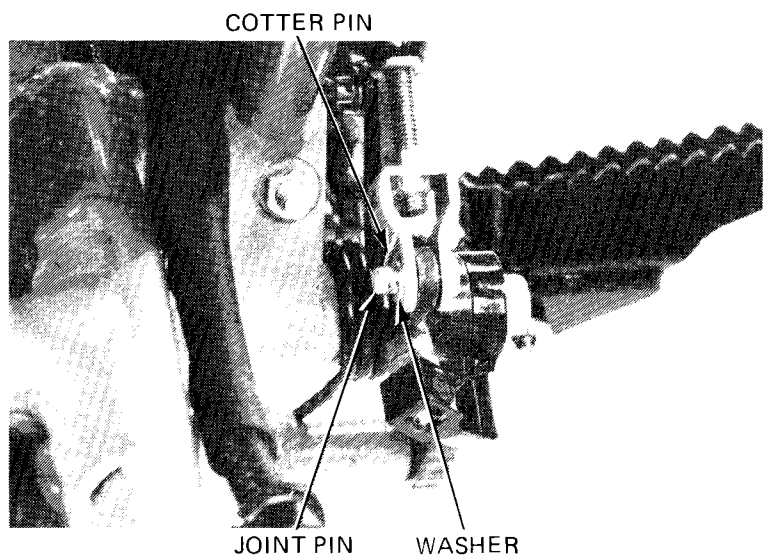

Connect the brake hoses to the master cylinder. Tighten the brake hose bolt.

TORQUE: 30–40 N·m (3.0–4.0 kg·m, 22–29 ft·lb)

Fill the brake fluid reservoir and bleed the rear brake system (page 14-3).

Adjust the rear brake pedal height (page 3-12).

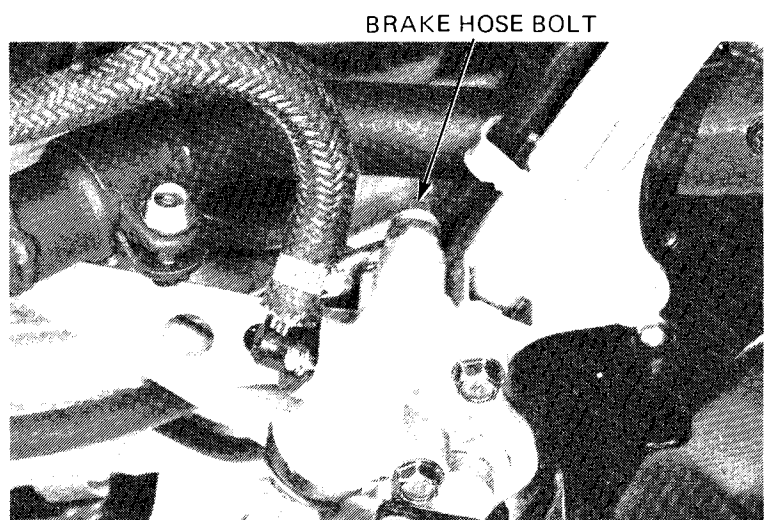

MEMO

15.REAR FENDER/EXHAUST SYSTEM

REAR FENDER

15-1

EXHAUST SYSTEM

15-2

REAR FENDER

REMOVAL

Release the seat lock by moving the lever in the direction shown.

Remove the seat.

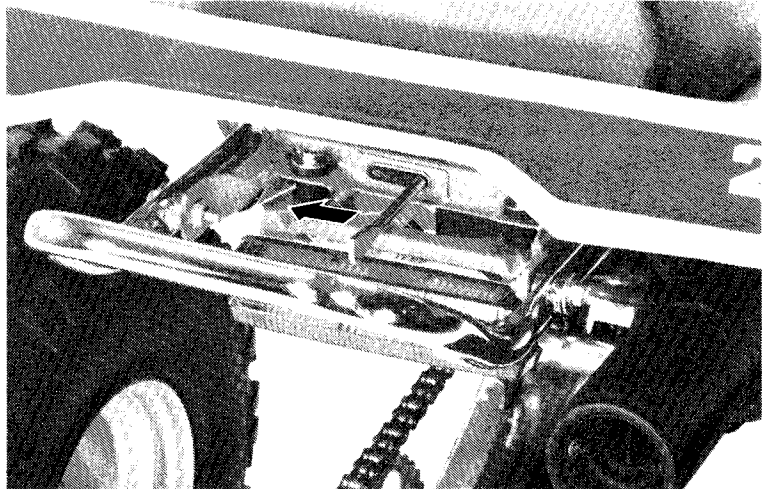

INSTALLATION

The installation sequence is the reverse order of removal.

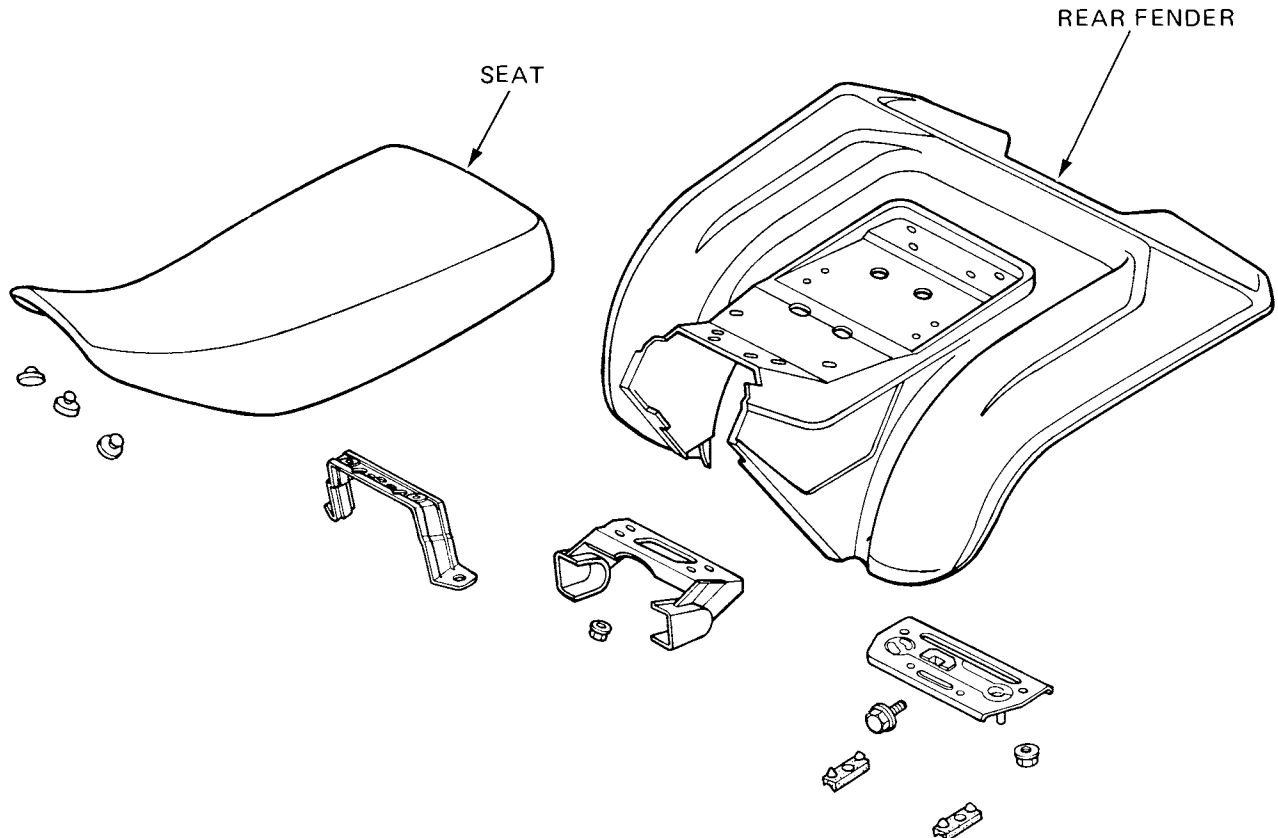

15

EXHAUST SYSTEM

REMOVAL

WARNING

Do not service the exhaust pipe or muffler while they are hot.

Remove the seat/rear fender.
Remove the exhaust pipe flange nuts.
Loosen the clamp bolt and remove the exhaust pipe.
Remove the two muffler mount bolts and remove the muffler.

NOTE:

Check the gasket and pipe seal for wear.
Replace with a new one if necessary.

INSTALLATION

The installation sequence is essentially the reverse of removal.

NOTE:

- Tighten the exhaust flange nuts first, then tighten the other bolts.
- Align the tab of the clamp with the groove of the muffler.
- After installing, make sure that there are no exhaust leaks.

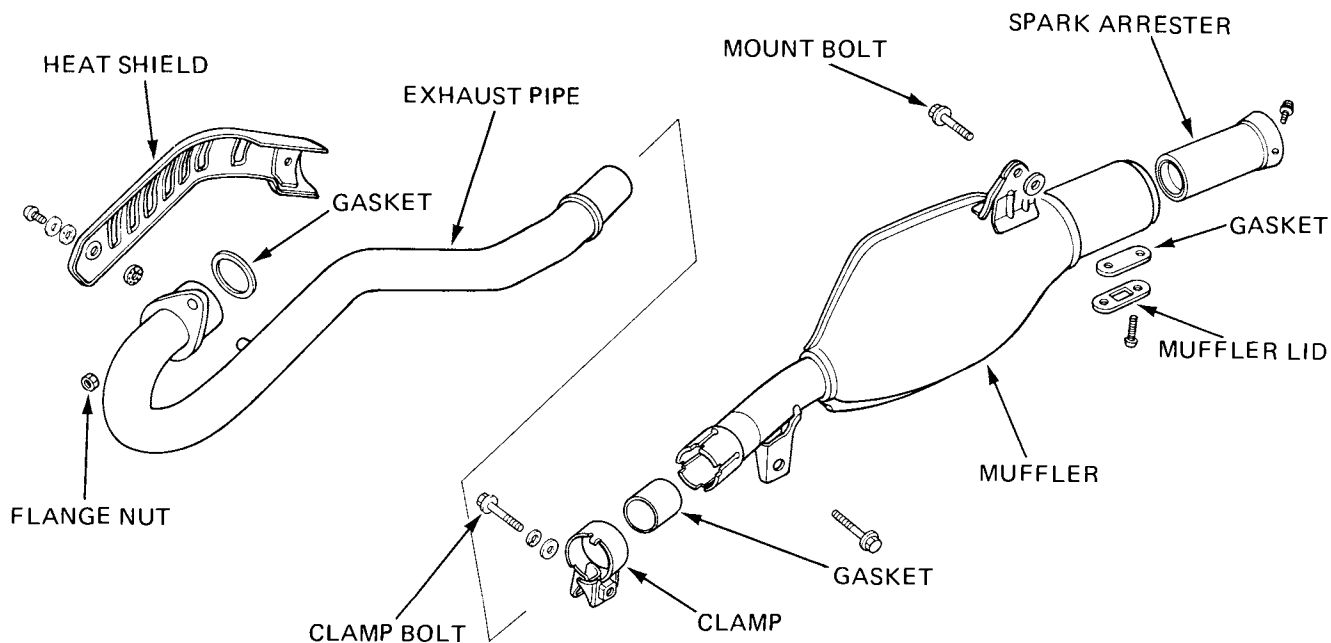

M E M O

ELECTRICAL SYSTEM

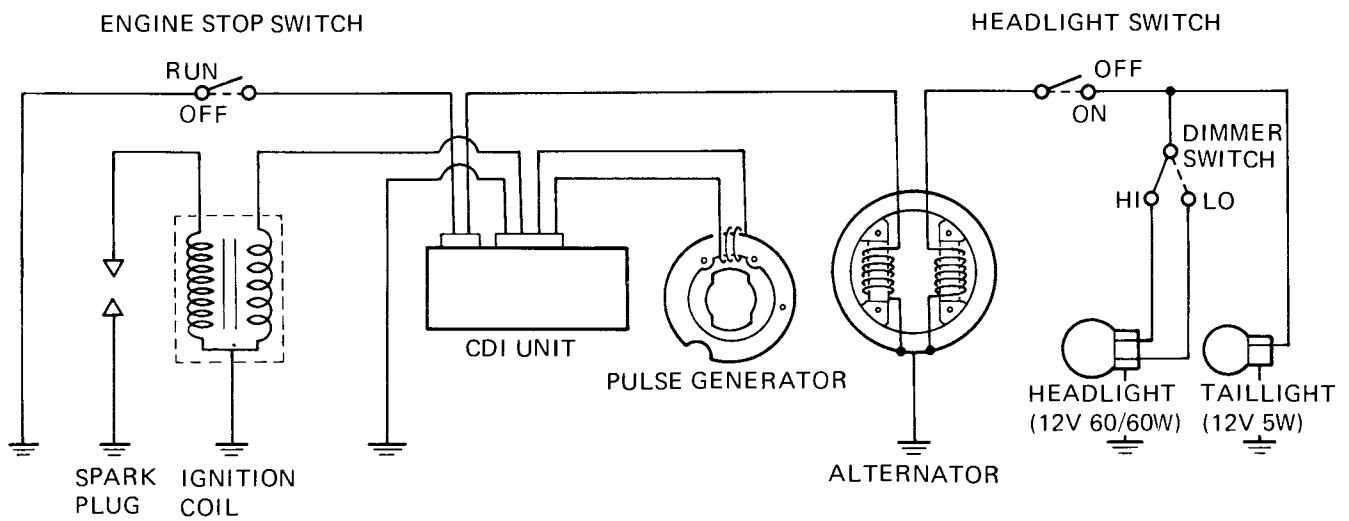
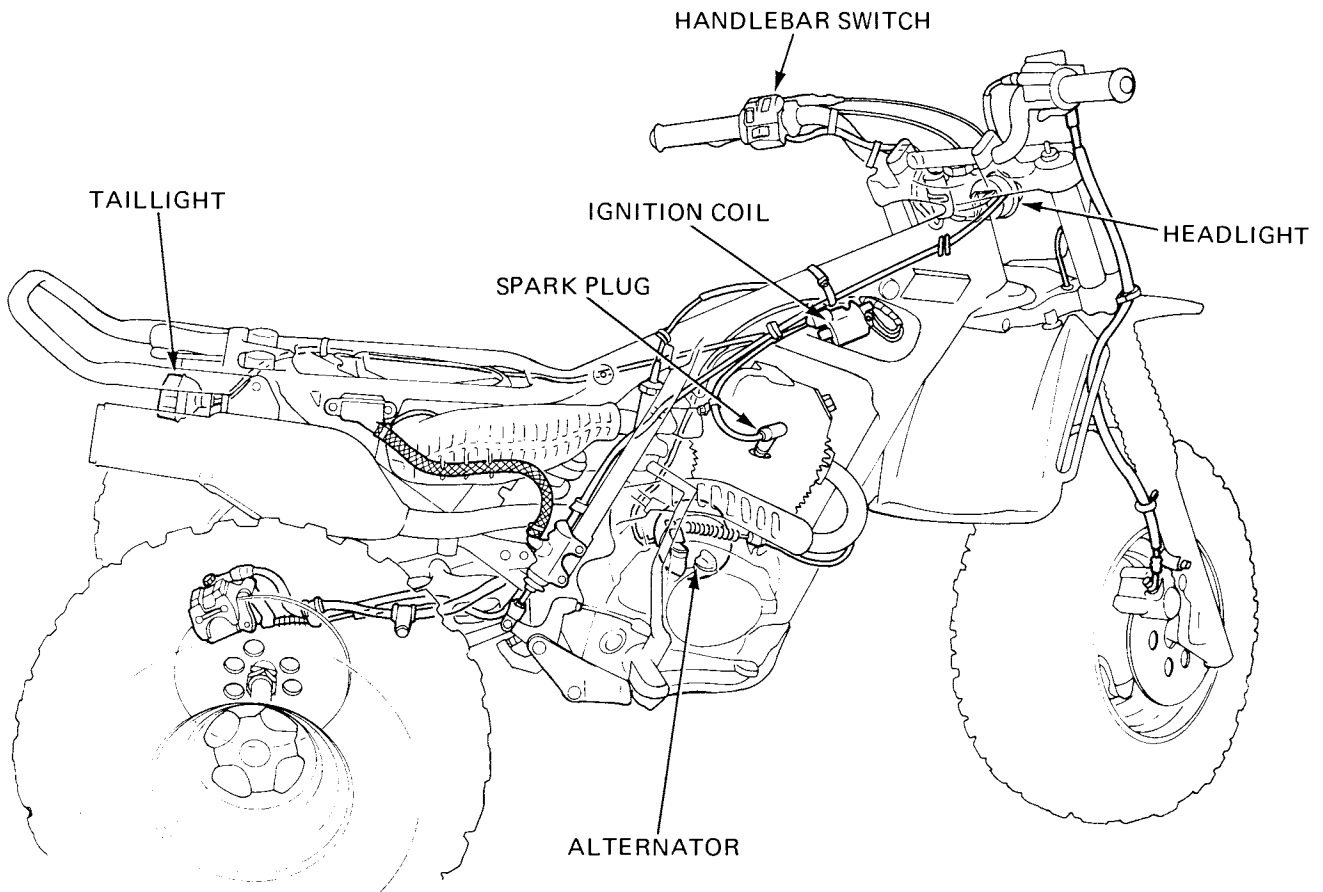

16. ELECTRICAL SYSTEM

SERVICE INFORMATION	16-1
TROUBLESHOOTING	16-2
IGNITION COIL	16-3
ALTERNATOR	16-3
CDI UNIT	16-4
PULSE GENERATOR	16-5
SPARK ADVANCER	16-5
IGNITION TIMING	16-6
TAILLIGHT	16-7
HANDLEBAR SWITCH	16-7
WIRING DIAGRAM	16-8

SERVICE INFORMATION

GENERAL

- Ignition timing does not normally need to be adjusted since the CDI (Capacitive Discharge Ignition) unit is factory pre-set.
- For spark plug inspection, refer to page 3-4.
- For pulse generator removal, see page 6-4.
- All plastic connectors have locking tabs that must be released before disconnecting, and must be aligned when reconnecting.
- To isolate an electrical failure, check the continuity of the electrical path through the part. A continuity check can usually be made without removing the part from the motorcycle—by simply disconnecting the wires and connecting a continuity tester or voltmeter to the terminals or connections.

SPECIFICATIONS

Spark plug: X24ESR-U (ND)
DR8ES-L (NGK)
RA6YC (CHAMPION)

Spark plug gap 0.6–0.7 mm (0.024–0.028 in)

Ignition timing:

Initial

1983	$10^{\circ} \pm 2^{\circ}$ BTDC at idle
After 1983	$5^{\circ} \pm 2^{\circ}$ BTDC at idle

Full advance

1983	$30^{\circ} \pm 2^{\circ}$ BTDC 3,350 \pm 150 rpm
After 1983	$30^{\circ} \pm 2^{\circ}$ BTDC 3,150 \pm 150 rpm

Alternator 68W/5,000 rpm
Headlight 12V–60W/60W
Taillight 12V–5W

TROUBLESHOOTING

Engine starts but stops

1. No spark at plug.
2. Improper ignition timing.
3. Faulty spark plug.

No spark at plug

1. Engine stop switch "OFF"
2. Poorly connected, broken or shorted wires.
 - Between alternator and CDI unit.
 - Between CDI unit and engine stop switch.
 - Between CDI unit and ignition coil.
 - Between ignition coil and spark plug.
 - Between pulse generator and CDI unit.
3. Faulty ignition coil.
4. Faulty CDI unit.
5. Faulty pulse generator.
6. Faulty alternator.
7. Improper pulse generator coil air gap.

Engine starts but runs poorly

1. Ignition primary circuit.
 - Faulty ignition coil.
 - Loose or bare wire.
 - Faulty alternator.
 - Faulty CDI unit.
 - Faulty pulse generator.
2. Ignition secondary circuit.
 - Faulty plug.
 - Faulty spark plug wire.
 - Faulty ignition coil.
3. Improper ignition timing.
 - Faulty advancer rotor.
 - Faulty pulse generator.
 - Faulty CDI unit.

Hard starting

1. Improper pulse generator coil air gap.

No lights come on when engine is started

1. Faulty bulb.
2. Poorly connected or loose connectors.
3. Alternator lighting coil open (page 16-3).

Engine will not stop when engine stop switch is turned "OFF"

1. Faulty switch.
2. Poorly connected, loose or broken switch wire.

Engine will not start

1. Engine stop switch wires shorted.

IGNITION COIL

REMOVAL

Remove the seat/rear fender and fuel tank.
 Disconnect the wire leads.
 Remove the spark plug cap from the spark plug.
 Remove the ignition coil by removing the mounting bolts.

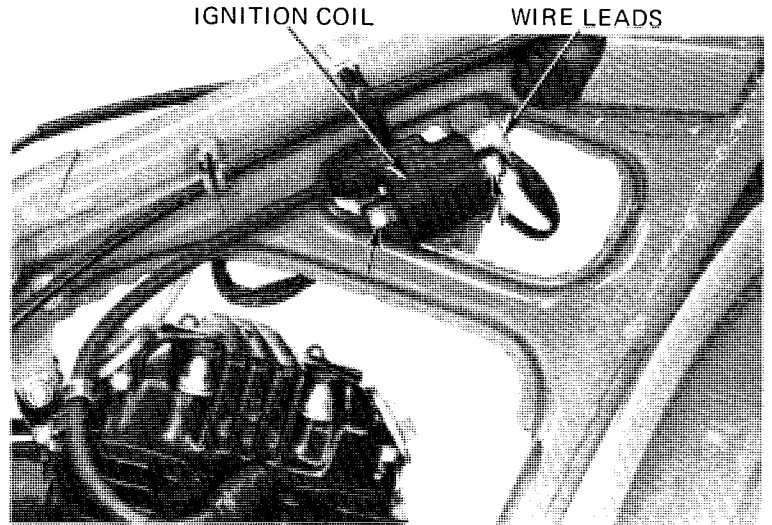

INSPECTION

Check the resistances between the leads of the primary and secondary coils:

Primary coil: 0.2–0.8 Ω

Secondary coil: 3–5 k Ω

INSTALLATION

Install the ignition coil in the reverse order of removal.

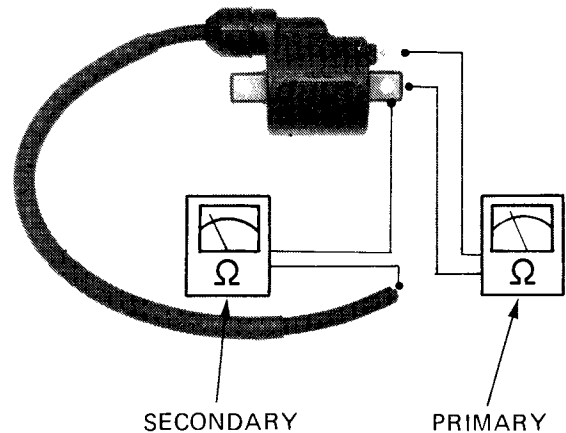

ALTERNATOR

Disconnect the alternator wire connector and test as follows:

NOTE:

It is not necessary to remove the stator coil to make this test.

LIGHTING COIL

The lamp coil is correct if there is continuity between the yellow wire and body ground.

EXCITER COIL

The exciter coil is normal if there is continuity between the black/red wire and body ground.

RESISTANCE: 100–400 Ω

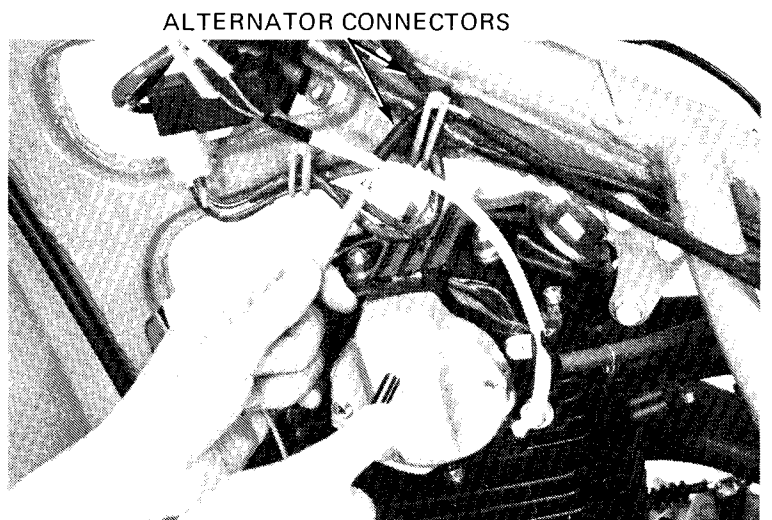

ELECTRICAL SYSTEM

CDI UNIT

REMOVAL

Remove the seat/rear fender and fuel tank.
 Disconnect the coupler.
 Remove the CDI unit from the mounting rubber.

INSPECTION

Replace the CDI unit if the readings are not within the limits shown in the table.

NOTE:

- The CDI unit is fully transistorized.
- For accurate testing, it is necessary to use a specified electric tester. Use of an improper tester may give a false reading.
- Use Sanwa Electric Tester (P/N 07308-0020000) or Kowa Digital Multi-Tester (KS-AHM-32-003: U.S.A. only).

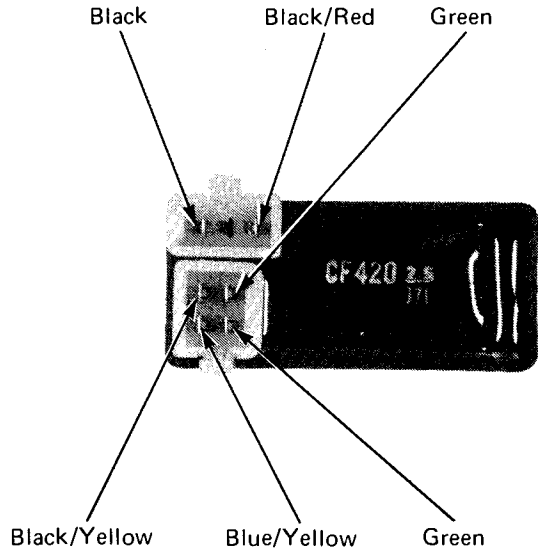

1983

Unit: KΩ

(-) (+)	BLACK	GREEN	BLACK/RED	GREEN	BLUE/YELLOW	BLACK/YELLOW
BLACK		∞	∞	∞	∞	∞
GREEN	10-100		1-30		∞	∞
BLACK/RED	0.3-20	∞		∞	∞	∞
GREEN	10-100		1-30		∞	∞
BLUE/YELLOW	10-150	2-50	2-50	2-50		∞
BLACK/YELLOW	∞	∞	∞	∞	∞	

After 1983

Unit: KΩ

(-) (+)	BLACK	GREEN	BLACK/RED	GREEN	BLUE/YELLOW	BLACK/YELLOW
BLACK		∞	∞	∞	∞	∞
GREEN	0.5-100		0.2-20		∞	∞
BLACK/RED	0.2-20	∞		∞	∞	∞
GREEN	0.5-100		0.2-20		∞	∞
BLUE/YELLOW	5-200	0.5-100	2-100	0.5-100		∞
BLACK/YELLOW	∞	∞	∞	∞	∞	

PULSE GENERATOR

NOTE:

This test can be made without removing the part.

Remove the seat/rear fender and fuel tank.
Disconnect the generator wires.

Measure the resistance between the Blue/Yellow and Green wires.

RESISTANCE:

1983	30–200 Ω
After 1983	50–150 Ω

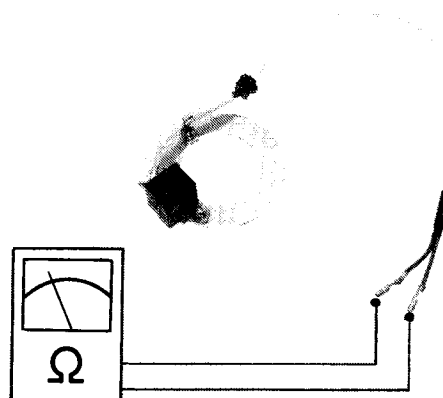

SPARK ADVANCER

INSPECTION

Check the pulse generator rotor for smooth operation.

Check for a weak spring or worn advancer pin.

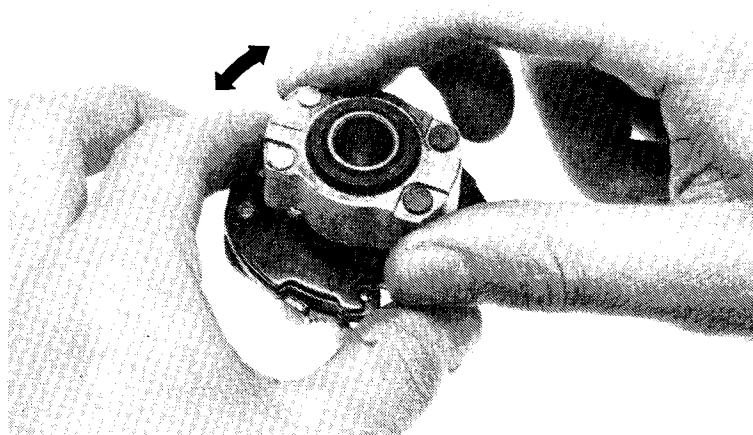

ASSEMBLY

Before installing, apply grease to the sliding faces of the rotor.

Install the rotor so that the mark on the rotor is on the same side as the advancer mark.

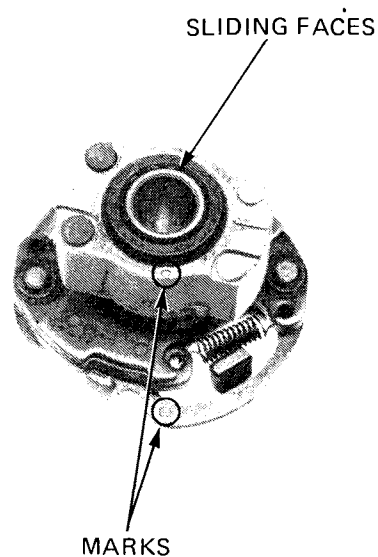

ELECTRICAL SYSTEM

IGNITION TIMING

INSPECTION

Remove the timing hole cap.
Connect a timing light and tachometer.

Start the engine and check the ignition timing:

At $1,300 \pm 100$ rpm: The index mark should be aligned with the F mark.

At $1,950 \pm 150$ rpm: Timing advance should start.

At $3,350 \pm 150$ rpm: Timing advance should cease.
The index mark should be between the full advance marks.

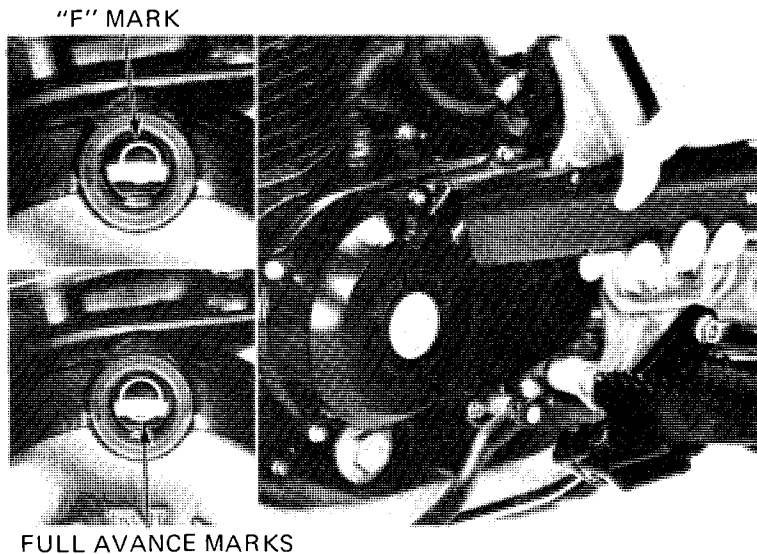

ADJUSTMENT

Remove the pulse generator cover.
Loosen the screws attaching the pulse generator base plate and rotate the base plate until the correct ignition timing is obtained.

Turn the base plate in direction A to advance the timing.

Turn the base plate in direction B to retard the timing.

Recheck the ignition timing.

Check the pulse generator gap below.

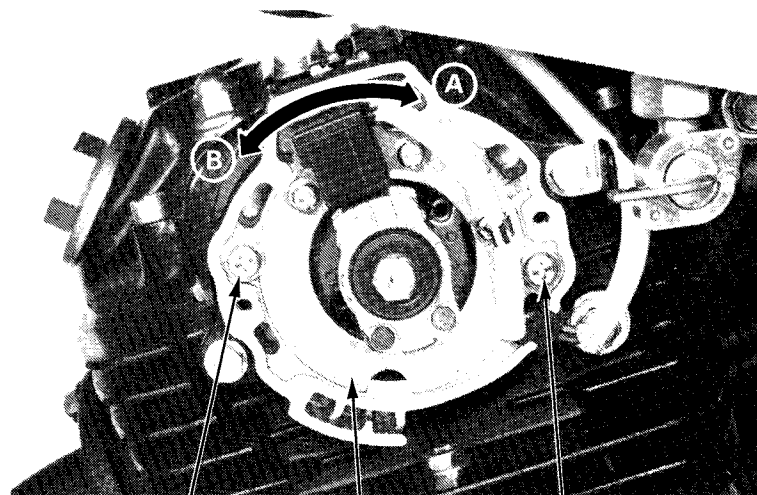

SCREW PULSE GENERATOR SCREW
BASE PLATE
PULSE GENERATOR

PULSE AIR GAP ADJUSTMENT

Measure the air gap between the pulse generator and rotor.

AIR GAP: 0.3–0.4 mm (0.012–0.016 in)

When adjustment is necessary, loosen the pulse generator coil attaching screws and move the coil to achieve the correct gap.

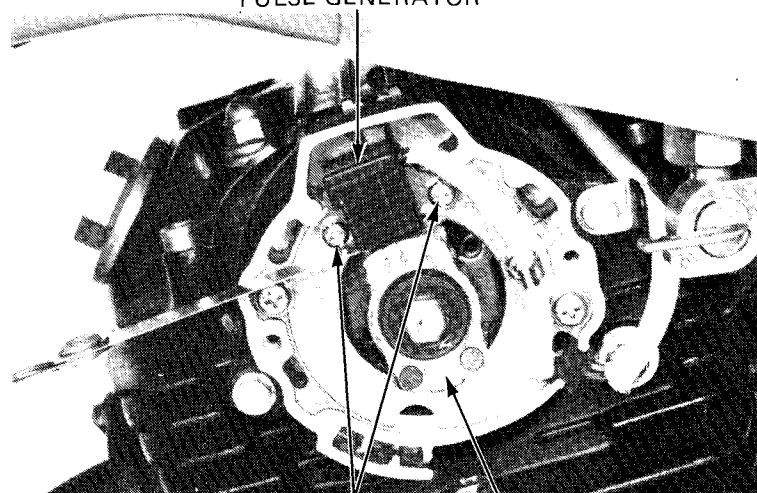

SCREWS ROTOR

TAILLIGHT

TAILLIGHT DISASSEMBLY

Remove the lens screws.
Remove the bulb.

TAILLIGHT ASSEMBLY

Assemble the taillight in the reverse order of disassembly.

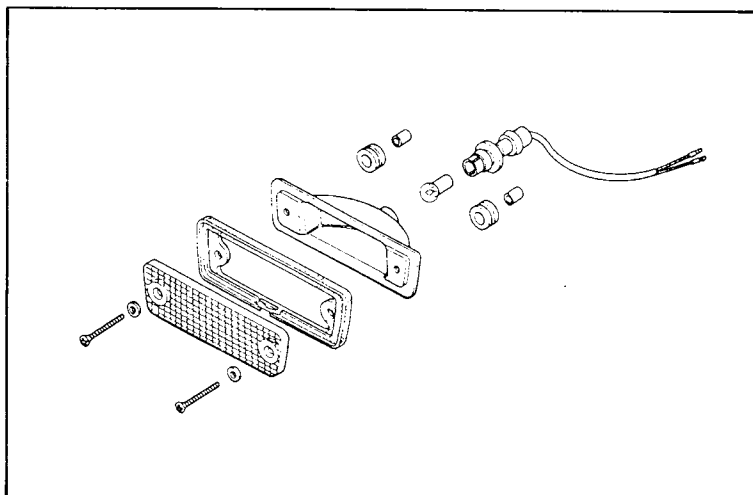

HANDLEBAR SWITCH

Remove the headlight case (page 11-3).
Disconnect the switch coupler and connector.
Check each switch for continuity between the terminals shown in the table for each switch position.

LIGHT SWITCH

	YELLOW	BROWN
OFF		
ON	○	○

DIMMER SWITCH

	BROWN	BLUE	WHITE
HI	○	○	
(N)	○	○	○
LO	○		○

ENGINE STOP SWITCH

	BLACK	GREEN	
OFF	○	○	
RUN			

The switch is normal if there is continuity between the circuit marked "○-○".

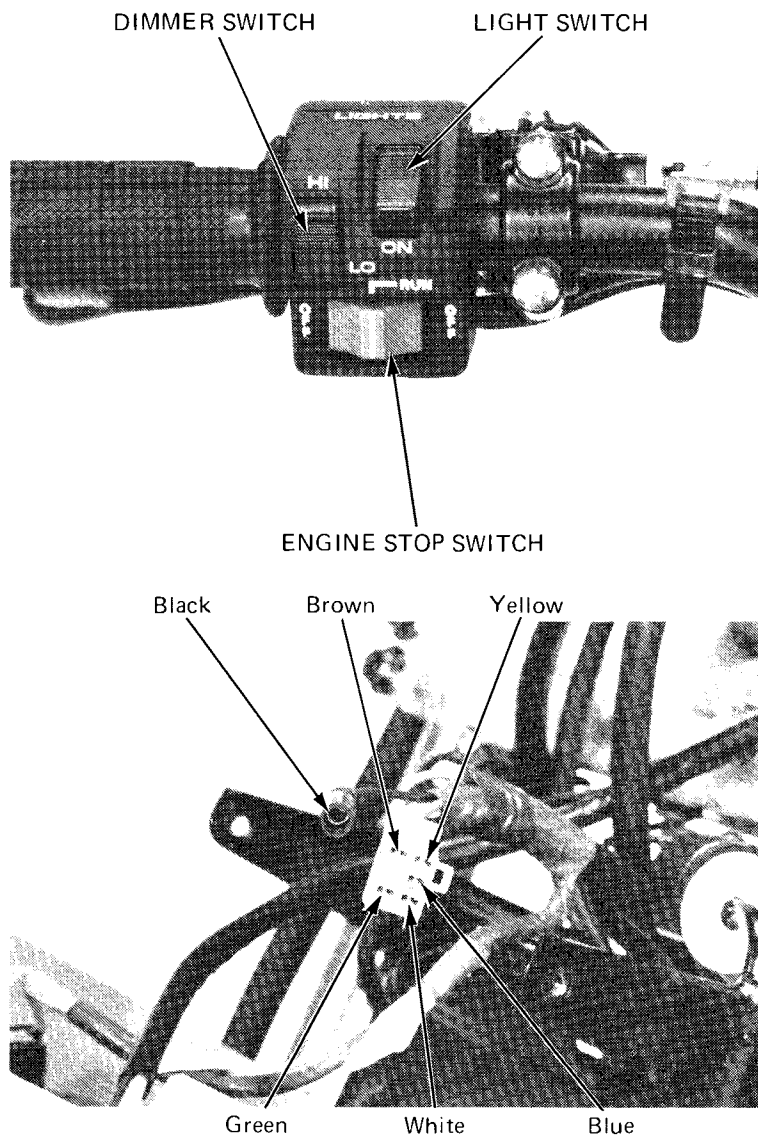

WIRING DIAGRAM

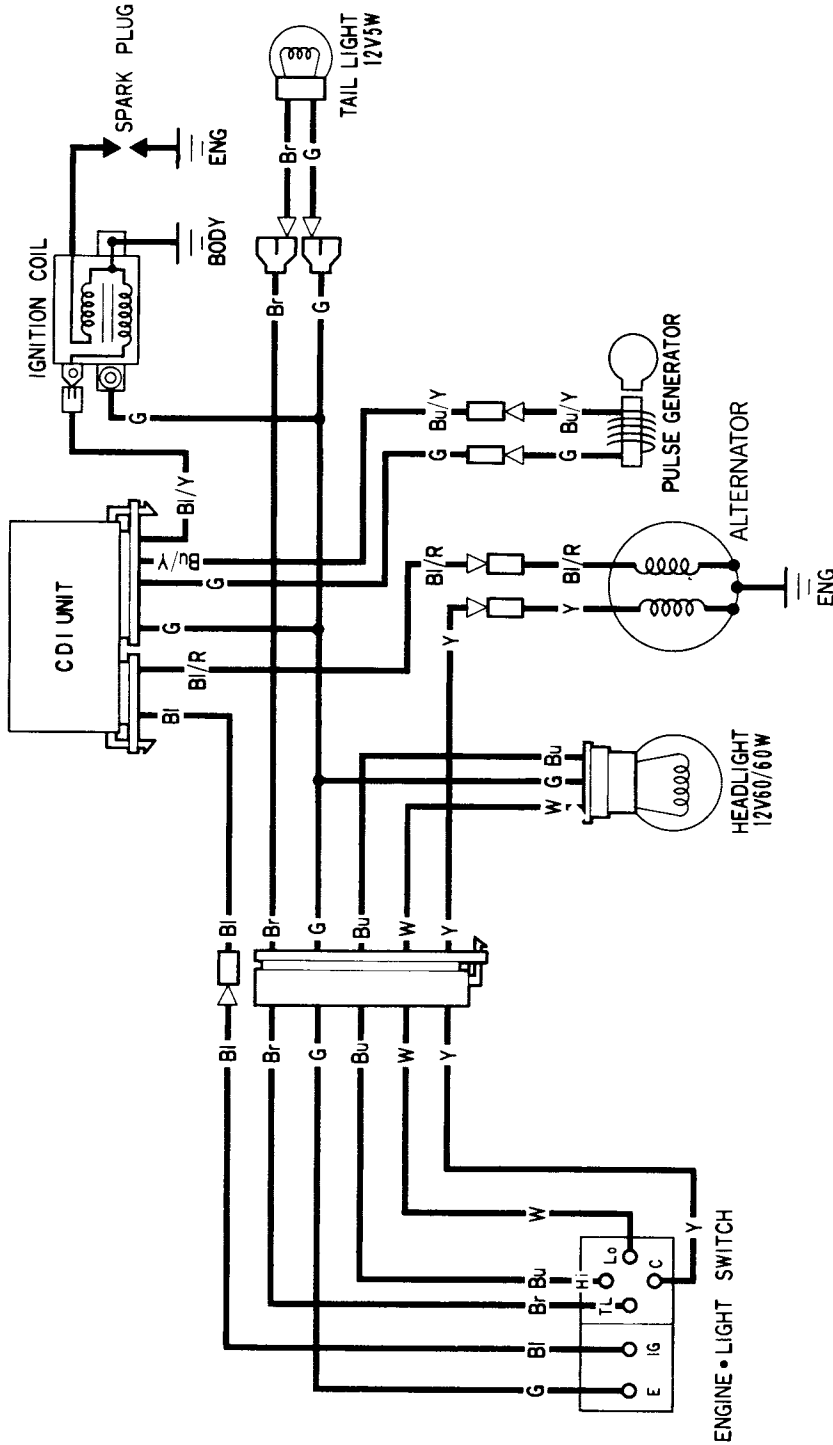

- BI BLACK
- Y YELLOW
- Bu BLUE
- G GREEN
- R RED
- W WHITE
- Br BROWN
- O ORANGE
- Lb LIGHT BLUE
- Lg LIGHT GREEN
- P PINK
- Gr GRAY

SWITCH CONTINUITY

LIGHT SWITCH		DIMMER SWITCH				ENGINE SWITCH		
	C TL	TL	Hi	Lo		IG	E	
OFF		○	○	○		○	○	
ON	○	○	○	○				
COLOR	Y	Br	Bu	W		BI	G	

0030Z-965-0100

17. TROUBLESHOOTING

ENGINE DOES NOT START OR IS HARD TO START	17-1
ENGINE LACKS POWER	17-2
POOR PERFORMANCE AT LOW AND IDLE SPEEDS	17-3
POOR PERFORMANCE AT HIGH SPEEDS	17-4
POOR HANDLING	17-4

ENGINE DOES NOT START OR IS HARD TO START

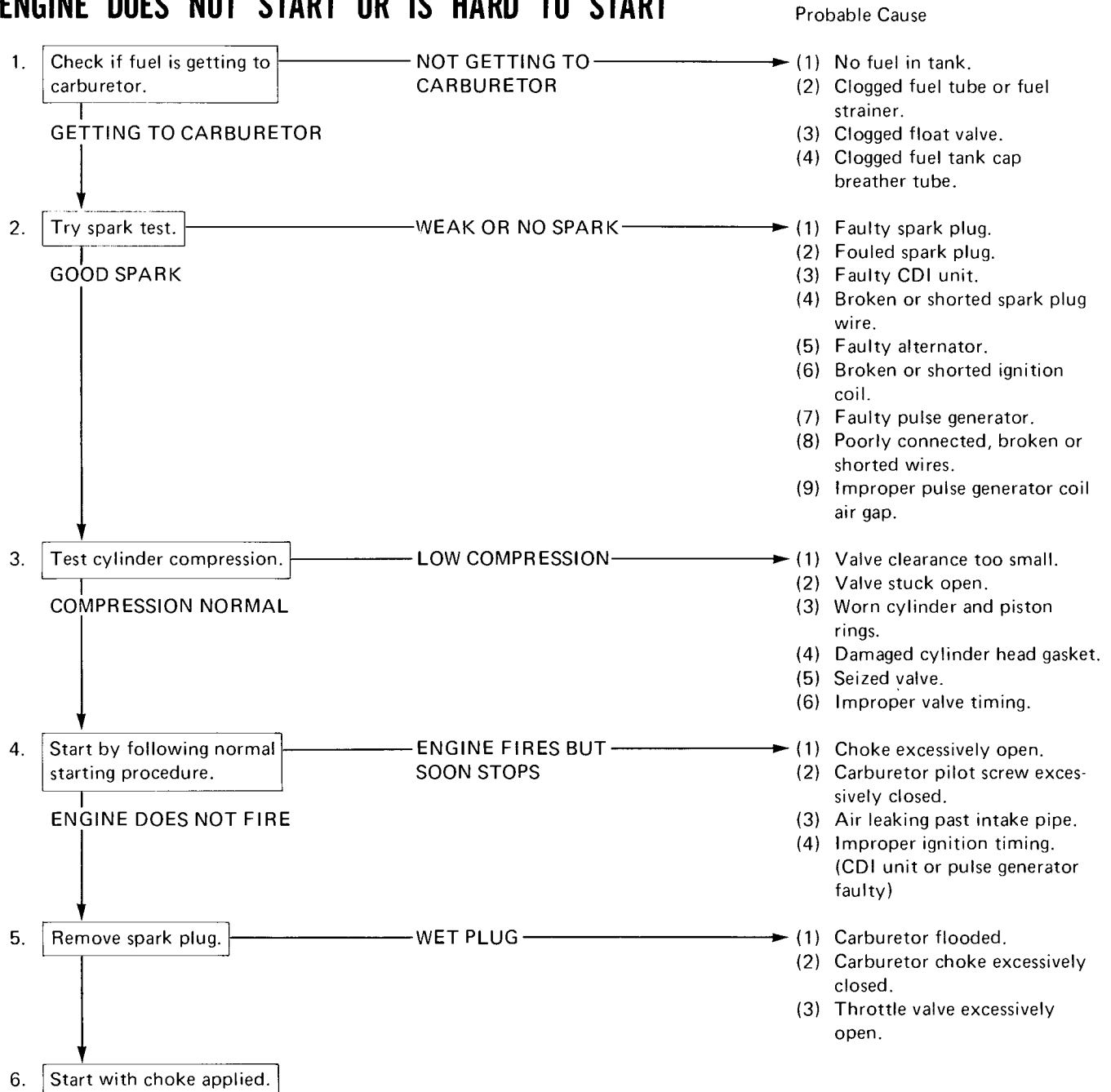

ENGINE LACKS POWER

Probable Cause:

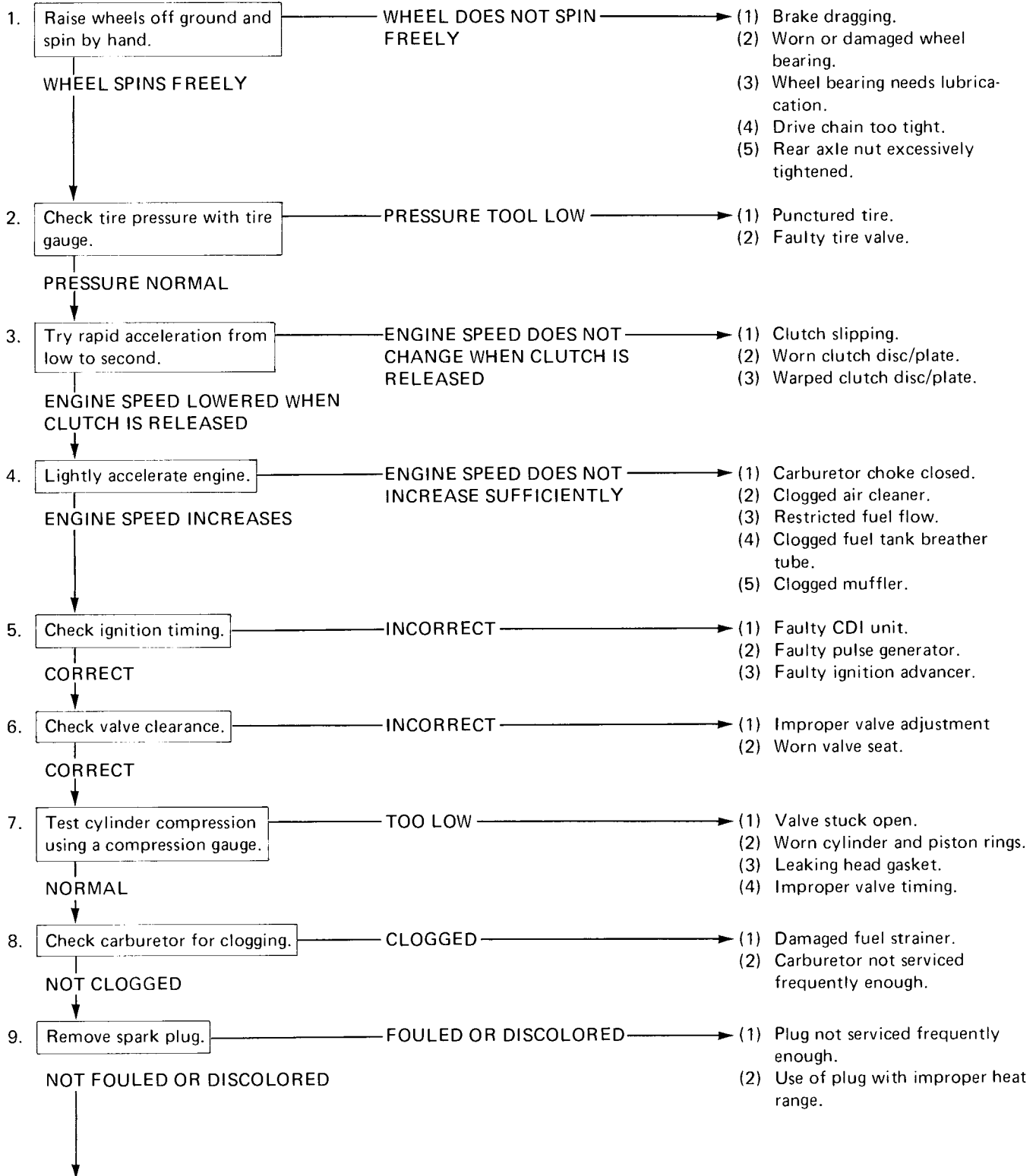

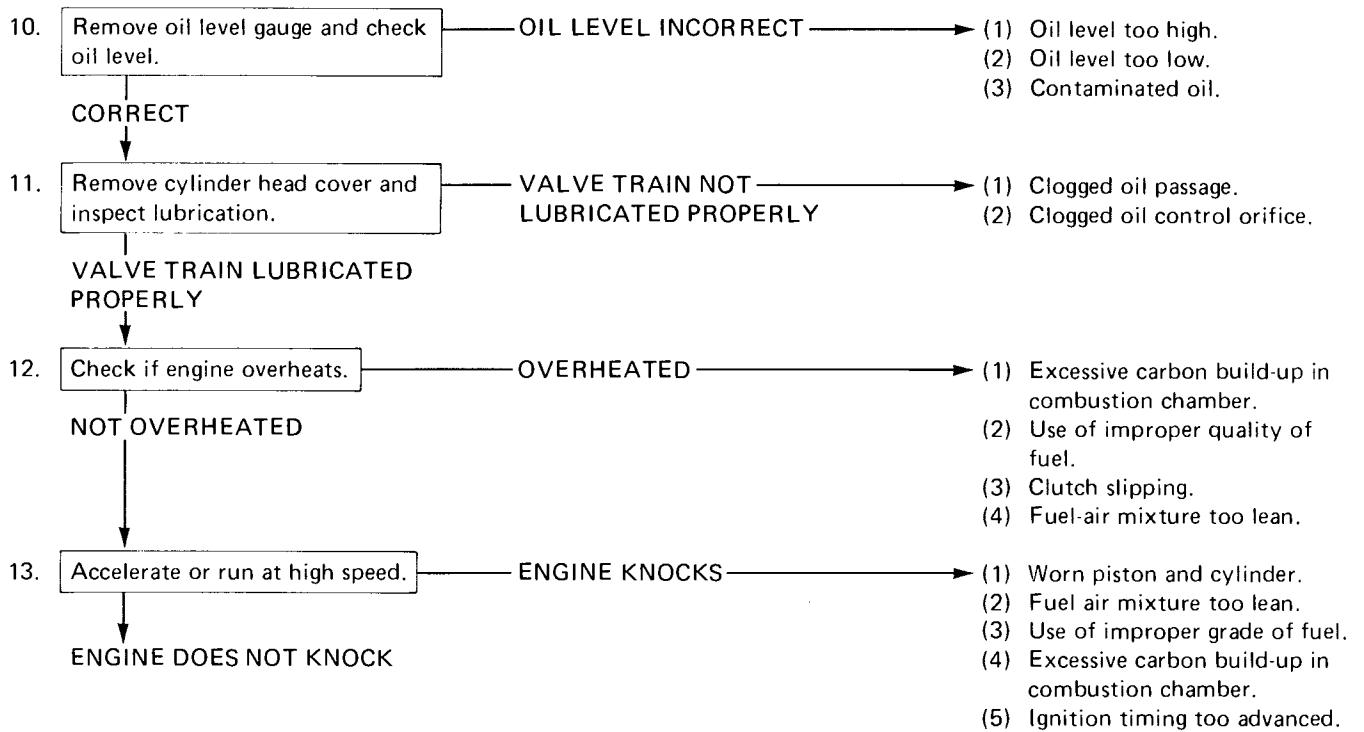

POOR PERFORMANCE AT LOW AND IDLE SPEEDS

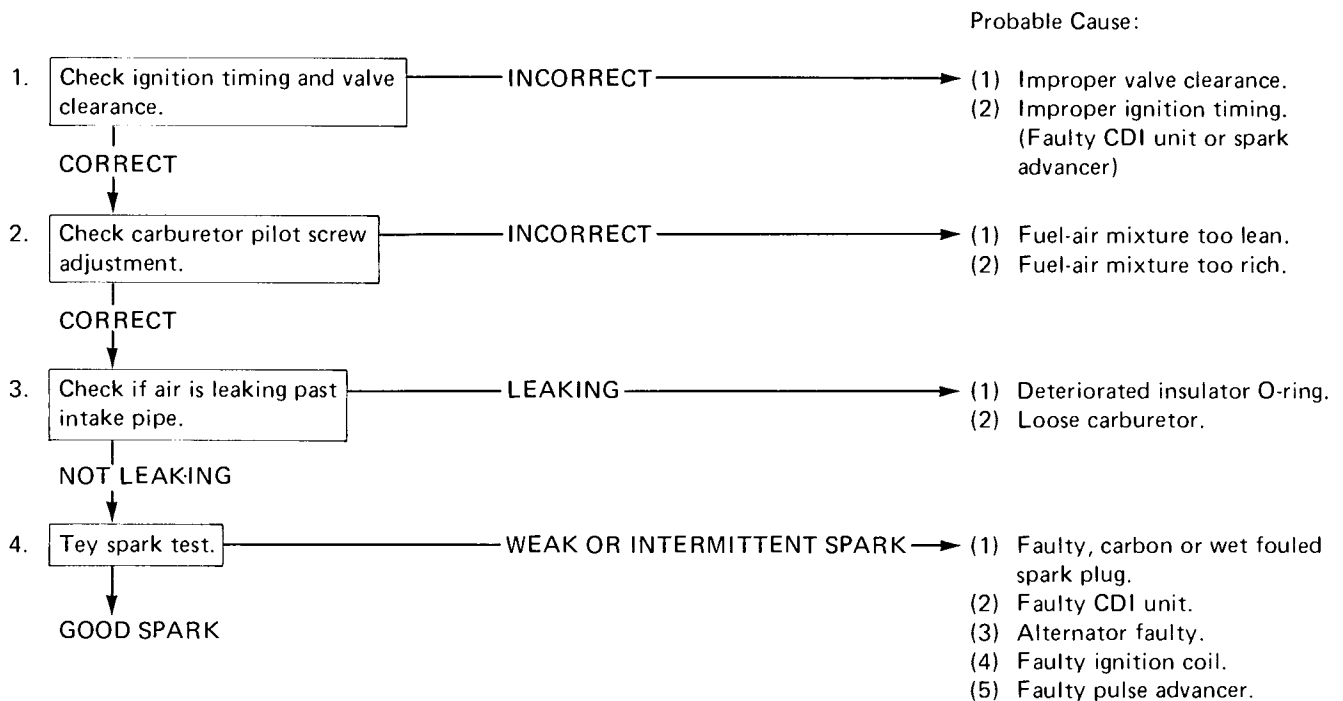

POOR PERFORMANCE AT HIGH SPEEDS

Probable Cause:

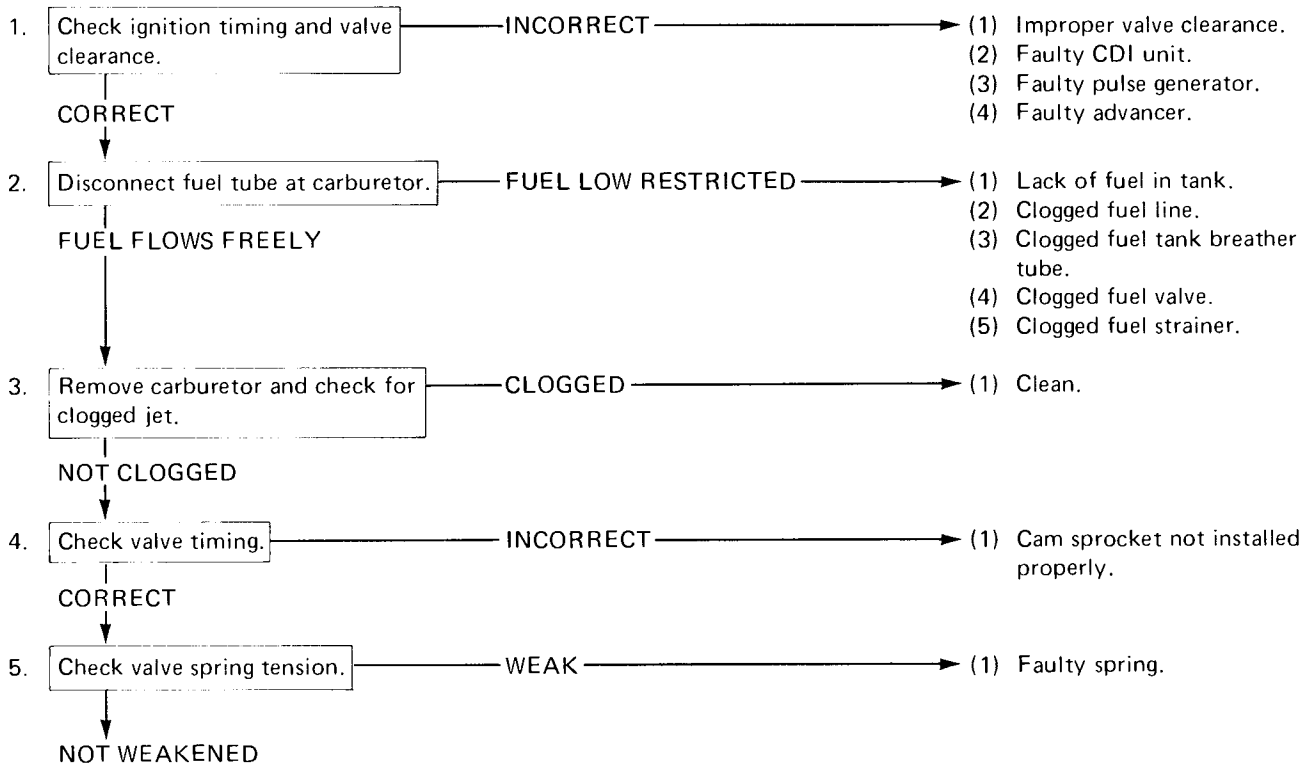

POOR HANDLING

→ Check tire pressure

Probable Cause:

1. If steering is heavy → (1) Steering head adjust nut too tight.
(2) Damaged steering stem bearings.
2. If either wheel is wobbling → (1) Excessive wheel bearing play.
(2) Bent rim.
(3) Improperly installed wheel hub.
(4) Swingarm pivot bearings excessively worn.
(5) Bent frame.
(6) Improper drive chain tension or adjustment.
3. If the vehicle pulls to one side → (1) Rear tire pressure not equal.
(2) Bent front fork.
(3) Bent swingarm.
4. If the front suspension is too soft → (1) Weak springs.
(2) Insufficient front fork oil.
(3) Low air pressure in forks.

5. If the front suspension is too stiff → (1) Incorrect front fork oil viscosity too high.
(2) Excessive front fork fluid.
(3) Excessive fork air pressure.
6. If the rear suspension is too soft → (1) Weak spring.
(2) Improper rear suspension adjustment.
(3) Insufficient nitrogen gas pressure.
7. If the rear suspension is too stiff → (1) Improper rear suspension adjustment.
(2) Bent shock absorber rod.

MEMO