

HONDA

SERVICE MANUAL

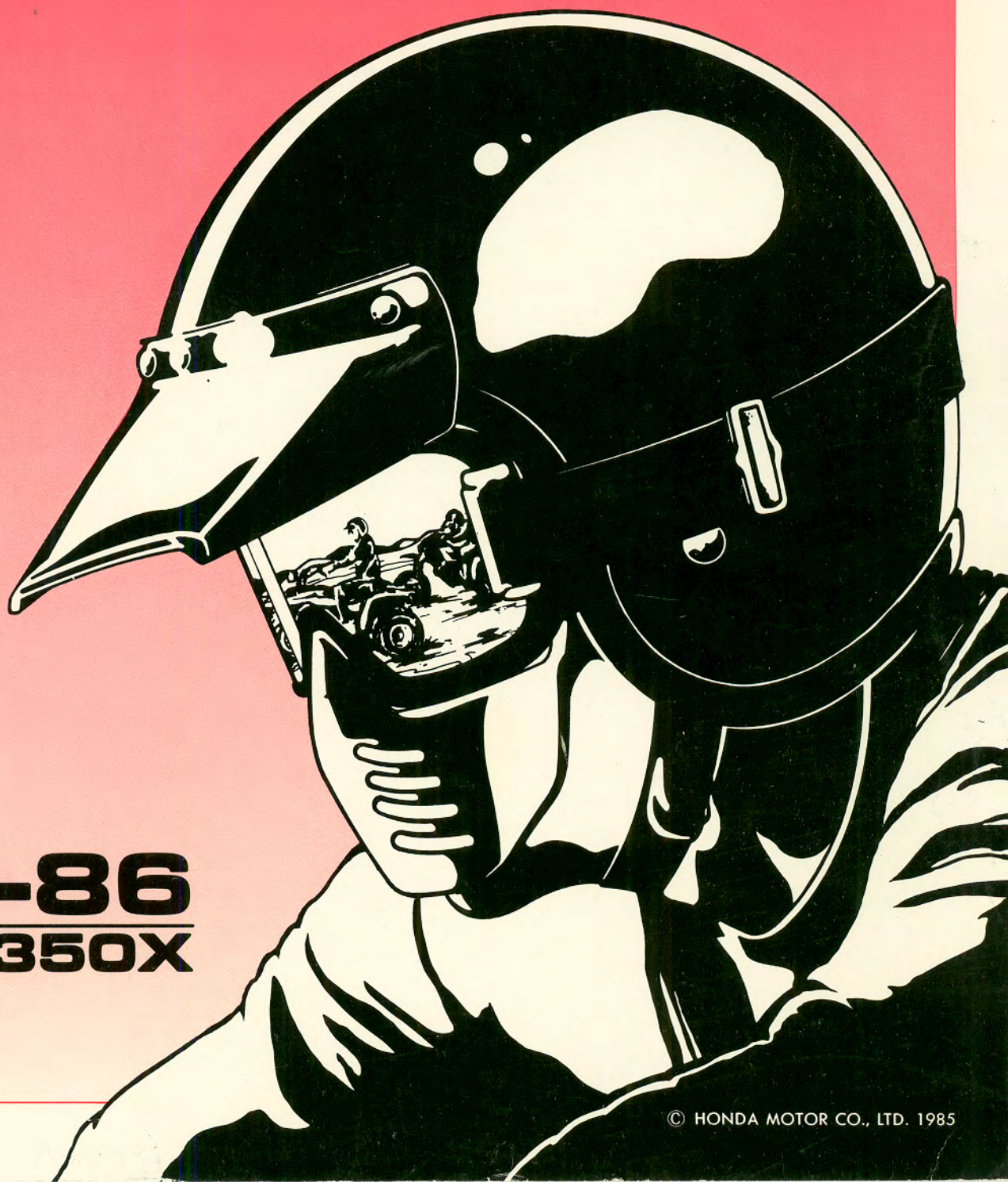

85-86
ATC[®] 350X

Thank you for your patronage.

This CD was purchased from @home backup. If it was purchased or obtained by any other means, you have illegally obtained this CD and are in violation of its copyrights.

Report copyright violations to: @home backup
Attn: Manual Backups
2902 Grasmere St.
Garland, TX 75040

Unauthorized duplication or distribution is strictly prohibited.

IMPORTANT SAFETY NOTICE



WARNING

Indicates a strong possibility of severe personal injury or loss of life if instructions are not followed.

CAUTION: *Indicates a possibility of personal injury or equipment damage if instructions are not followed.*

NOTE: Gives helpful information.

Detailed descriptions of standard workshop procedures, safety principles and service operations are not included. It is important to note that this manual contains some warnings and cautions against some specific service methods which could cause **PERSONAL INJURY** to service personnel or could damage a vehicle or render it unsafe. Please understand that those warnings could not cover all conceivable ways in which service, whether or not recommended by Honda might be done or of the possibly hazardous consequences of each conceivable way, nor could Honda investigate all such ways.

Anyone using service procedures or tools, whether or not recommended by Honda *must satisfy himself thoroughly* that neither personal safety nor vehicle safety will be jeopardized by the service method or tools selected.

HOW TO USE THIS MANUAL

Sections 1 through 3 apply to the whole ATC, while sections 4 through 16 describe parts of the ATC, grouped according to location.

Find the section you want on this page, then turn to the table of contents on page 1 of that section.

Most sections start with an assembly or system illustration and all the required specifications, torque values, general instructions, tools and troubleshooting for the section. The subsequent pages give detailed procedures.

If you don't know what the source of a problem, refer to section 17, TROUBLESHOOTING.

All information, illustrations, directions and specifications included in this publication are based on the latest product information available at the time of approval for printing.
Honda Motor CO., LTD. reserves the right to make changes at any time without notice and without incurring any obligation whatever.
No part of this publication may be reproduced without written permission.

HONDA MOTOR CO., LTD.
Service Publications Office

CONTENTS

	GENERAL INFORMATION	1
	LUBRICATION	2
	MAINTENANCE	3
ENGINE	FUEL SYSTEM	4
	ENGINE REMOVAL/INSTALLATION	5
	CYLINDER HEAD/VALVES	6
	CYLINDER/PISTON	7
	CLUTCH/OIL PUMP/KICK STARTER	8
	ALTERNATOR/GEARSHIFT LINKAGE	9
	CRANKCASE/TRANSMISSION/ CRANKSHAFT	10
CHASSIS	FRONT WHEEL/SUSPENSION/STEERING	11
	REAR WHEELS	12
	REAR SUSPENSION	13
	HYDRAULIC BRAKES	14
	REAR FENDER/SEAT/EXHAUST SYSTEM	15
	ELECTRICAL SYSTEM	16
	TROUBLESHOOTING	17
	INDEX	18

1. GENERAL INFORMATION

GENERAL SAFETY	1-1	TOOLS	1-7
SERVICE RULES	1-1	CABLE & HARNESS ROUTING	1-9
MODEL IDENTIFICATION	1-2	NOISE EMISSION CONTROL SYSTEM (U.S.A. only)	1-13
SPECIFICATIONS	1-3		
TORQUE VALUES	1-5		

GENERAL SAFETY

WARNING

If the engine must be running to do some work, make sure that area is well-ventilated. Never run the engine in a closed area. The exhaust contains poisonous carbon monoxide gas.

WARNING

Gasoline is extremely flammable and is explosive under certain conditions. Do not smoke or allow flames or sparks in your work area.

SERVICE RULES

1. Use genuine HONDA or HONDA-recommended parts and lubricants or their equivalent. Parts that don't meet HONDA's design specifications may cause damage to the ATC.
2. Use the special tools designed for this product to avoid damage and incorrect assembly.
3. Use only metric tools when servicing this ATC. Metric bolts, nuts, and screws are not interchangeable with English fasteners.
4. Install new gaskets, O-rings, cotter pins, lock plates, etc. when reassembling.
5. When tightening bolts or nuts, begin with the larger-diameter or inner bolt first. Then tighten to the specified torque diagonally in 2 or 3 steps, unless a particular sequence is specified.
6. Clean parts in non-flammable or high flash point solvent upon disassembly.
7. Lubricate any sliding surfaces before reassembly.
8. After reassembly, check all parts for proper installation and operation.

GENERAL INFORMATION

MODEL IDENTIFICATION

'85:



After '85:

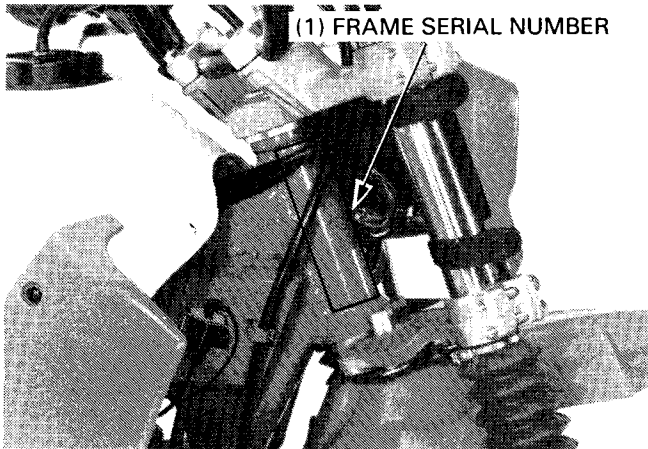
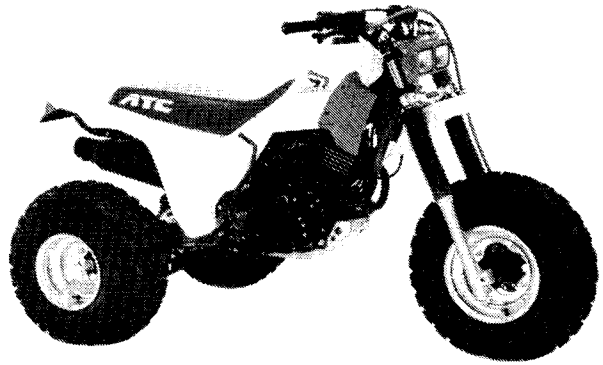

The frame serial number is stamped on the right side of the steering head.

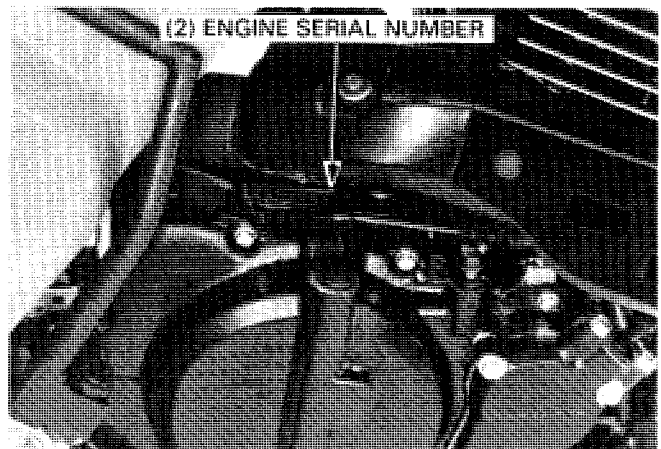

The engine serial number is stamped on the lower right side of the crankcase.

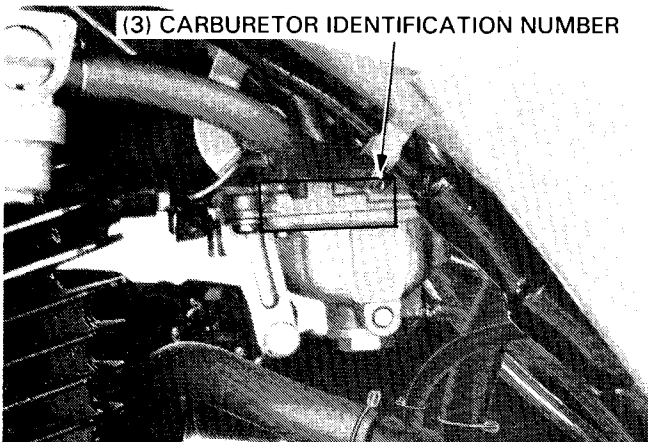

The carburetor identification number is on the carburetor body left side.

SPECIFICATIONS

<p>DIMENSIONS</p>	<p>Overall length Overall width Overall height Wheel base Rear tread Seat height Foot peg height Ground clearance Dry weight</p> <p style="text-align: right;">'85: After '85:</p>	<p>1,890 mm (74.4 in) 1,115 mm (43.9 in) 1,082 mm (42.6 in) 1,075 mm (42.3 in) 1,270 mm (50.0 in) 870 mm (34.3 in) 750 mm (29.5 in) 290 mm (11.4 in) 120 mm (4.7 in) 145 kg (320 lb)</p>
<p>FRAME</p>	<p>Type Front suspension, travel Rear suspension, travel Rim size Front tire size, pressure Rear tire size, pressure Front brake Rear brake Fuel capacity Fuel reserve capacity Caster Trail Front fork oil capacity</p> <p style="text-align: right;">Front Rear</p>	<p>Semi-double cradle Telescopic fork, 203 mm (8.0 in) Swing arm, 194 mm (7.6 in) 11 in 9 in 23.5 x 8 – 11 22.0 x 10 – 9 Single disc Single disc 9.7 liter (2.56 US gal, 2.13 Imp gal) 1.7 liter (0.45 US gal, 0.37 Imp gal) 23° 34.5 mm (1.36 in) 290 cc (9.8 US oz, 10.2 Imp oz)</p>
<p>ENGINE</p>	<p>Type Cylinder arrangement Bore x stroke Displacement Compression ratio Valve train Maximum horsepower Maximum torque Oil capacity Lubrication system Cylinder compression Intake valve Exhaust valve Valve clearance (Cold)</p> <p style="text-align: right;">Opens Closes Opens Closes Intake Exhaust</p>	<p>Gasoline, air-cooled 4-stroke Single cylinder inclined 20° 81 x 68 mm (3.2 x 2.7 in) 350.4 cc (21.38 cu in) 8.5: 1 Overhead camshaft chain drive 27PS/7,000 rpm 3.0 kg-m/6,000 rpm (21.70 ft-lb/6,000 rpm) 2.3 liters (2.43 US qt, 2.03 Imp qt) at disas- sembly 1.8 liters (1.91 US qt, 1.59 Imp qt) after draining Forced pressure and wet sump 1.250 kPa (12.5 kg/cm², 178 psi) 5° BTDC 35° ABDC 5° BBDC 35° ATDC 0.08 mm (0.003 in) 0.08 mm (0.003 in)</p> <p style="text-align: right;">at 1 mm lift</p>
<p>CARBURETOR</p>	<p>Type Venturi dia. Main jet Pilot screw opening Jet needle Float level Idle speed</p>	<p>Dual valve 31 mm (1.22 in) # 138 1-3/4 3rd groove 18.5 mm (0.73 in) 1,400 ± 100 rpm</p>

GENERAL INFORMATION

DRIVE TRAIN	Clutch Transmission Primary reduction Gear ratio I Gear ratio II Gear ratio III Gear ratio IV Gear ratio V Gear ratio VI Final reduction Gearshift pattern Drive chain size/links	Wet multi-plate 6-speed constant mesh 2.833 (68/24) 2.750 (44/16) 2.050 (41/20) 1.609 (37/23) 1.308 (34/26) 1.103 (32/29) 0.935 (29/31) 3.077 (40/13) Left foot operated return system, 1-N-2-3-4-5-6 520/90 links
ELECTRICAL	Ignition system Initial ignition timing Full advance Alternator Spark plug Spark plug gap Headlight Taillight	CDI 10° BTDC 30° BTDC 200 W/5,000 rpm NGK DR8ES-L ND X24ESR-U 0.6-0.7 mm (0.024-0.028 in) 12 V-36.5/35 W x 2 12 V-5 W

TORQUE VALUES

ENGINE

Item	Thread dia. (mm)	Torque			
		N·m	kg-m	ft-lb	
Oil drain plug	'85:	12	15-25	1.5-2.5	11-18
	After '85:	12	20-30	2.0-3.0	15-22
Valve adjusting lock nut	6	15-18	1.5-1.8	11-13	
Cylinder head cover bolt	6SH	8-12	0.8-1.2	6-9	
	6	8-12	0.8-1.2	6-9	
	7	13-17	1.3-1.7	9-12	
Cylinder head cap nut	10	35-45	3.5-4.5	25-32	
Cylinder head bolt	10	35-45	3.5-4.5	25-32	
Cam sprocket bolt	7	17-23	1.7-2.3	12-17	
Spark plug	12	15-20	1.5-2.0	11-15	
Carburetor insulator band screw	5	3-5	0.3-0.5	2.2-3.6	
Cam chain tensioner lifter	6SH	8-12	0.8-1.2	6-9	
Cam chain tensioner lifter sealing bolt	6	8-12	0.8-1.2	6-9	
Kick starter ratchet guide socket bolt	6	10-14	1.0-1.4	7-10	
Right crankcase cover bolt	6SH	8-12	0.8-1.2	6-9	
Clutch lock nut	18	100-120	10.0-12.0	72-87	
Clutch lifter plate bolt	6	10-14	1.0-1.4	7-10	
Oil filter cover bolt	6SH	8-12	0.8-1.2	6-9	
Oil bolt	8	12-16	1.2-1.6	9-12	
Primary drive gear lock nut	20	60-80	6.0-8.0	43-58	
Left crankcase cover	6SH	8-12	0.8-1.2	6-9	
Gearshift return spring pin	8	18-25	1.8-2.5	13-18	
Shift drum center bolt	8	21-25	2.1-2.5	15-18	
Flywheel bolt	12	100-120	10.0-12.0	72-87	
Pulse generator screw	5	5-7	0.5-0.7	3.6-5.1	
Alternator stator bolt	6SH	8-12	0.8-1.2	6-9	
Cylinder base bolt	6SH	8-12	0.8-1.2	6-9	
Crankcase bolts	6SH	8-12	0.8-1.2	6-9	
Oil pipe mounting bolt	6SH	8-12	0.8-1.2	6-9	
Oil pipe bolt	7	10-14	1.0-1.4	7-10	
Breather plate socket bolt	6	10-14	1.0-1.4	7-10	
Drive sprocket	6	8-12	0.8-1.2	6-9	

FRAME

Item	Thread dia. (mm)	Torque			
		N·m	kg-m	ft-lb	
Drive chain adjuster lock bolt	'85:	8	13-18	1.3-1.8	9-13
	After '85:	8	18-25	1.8-2.5	13-18
Fuel strainer cup	24	3-5	0.3-0.5	2.2-3.6	
Fuel valve lock nut	18	20-25	2.0-2.5	15-18	
Parking brake adjuster lock nut	8	15-20	1.5-2.0	11-15	
Engine mounting bolt	8	24-35	2.4-3.5	17-25	
	10	55-65	5.5-6.5	40-48	
Front wheel nut	10	60-70	6.0-7.0	43-51	
Front axle	14	70-110	7.0-11.0	51-80	
Front axle holder nut	6	10-14	1.0-1.4	7-10	
Gear shift pedal bolt	6	14-18	1.4-1.8	10-13	

GENERAL INFORMATION

Item	Thread dia. (mm)	Torque		
		N·m	kg-m	ft-lb
Front fork socket bolt	8	15-25	1.5-2.5	11-18
Front fork tube cap	28	15-30	1.5-3.0	11-22
Front fork pinch bolt	8	18-25	1.8-2.5	13-18
Front fork boot band	3	0.6-1.2	0.06-0.12	0.4-0.9
Steering bearing adjustment nut	Initial	26	2.5-3.5	18-25
	Final '85:	26	7-8	5-6
	Final After '85:	26	10-11	7-8
Steering stem nut	24	90-120	9.0-12.0	65-87
Rear wheel nut	10	60-70	6.0-7.0	43-51
Rear axle outer lock nut	32	80-100	8.0-10.0	58-72
Rear axle inner lock nut	32	120-140	12.0-14.0	87-101
Driven sprocket nut	10	55-65	5.5-6.5	40-48
Rear axle nut	18	120-170	12.0-17.0	87-123
Shock absorber oil hose bolt	10	27.5-32.5	2.75-3.25	20-23
Shock absorber spring lock nut	50	80-100	8.0-10.0	58-72
Shock absorber upper mount bolt	10	40-50	4.0-5.0	29-36
Shock absorber lower mount bolt	10	40-50	4.0-5.0	29-36
Shock absorber bracket bolt	10	40-50	4.0-5.0	29-36
Swing arm pivot bolt	14	70-110	7.0-11.0	51-80
Rear brake torque link-to-swing arm bolt ('85)	8	8-11	0.8-1.1	6-8
Rear brake torque link-to-caliper bracket bolt ('85)	8	24-30	2.4-3.0	17-22
Brake air bleeder valve	8	4-7	0.4-0.7	3-5
Caliper mounting bolt	8	20-30	2.0-3.0	15-22
Brake pad pin bolt	8	15-20	1.5-2.0	11-15
Front brake disc mounting nut	'85:	8	2.0-3.0	15-22
	After '85:	8	3.5-4.0	25-29
Front brake disc mounting bolt	8	35-40	3.5-4.0	25-29
Rear brake disc mounting bolt	8	37-43	3.7-4.3	27-31
Brake hose oil bolt	10	25-35	2.5-3.5	18-25
Rear caliper socket bolt	8	20-25	2.0-2.5	15-18
Parking brake base bolt	8	20-25	2.0-2.5	15-18
Parking brake adjusting lock nut	8	15-20	1.5-2.0	11-15
Front brake lever pivot bolt/nut	6	8-12	0.8-1.2	6-9
Rear brake reservoir joint screw	4	1-2	0.1-0.2	0.7-1.5
Foot peg mounting bolt	10	40-50	4.0-5.0	29-36

Torque specifications listed above are for specific tightening points. If a torque specification is not listed, follow the standards given below.

STANDARD TORQUE VALUES

TYPE	TORQUE N·m (kg-m, ft-lb)	TYPE	TORQUE N·m (kg-m, ft-lb)
5 mm bolt, nut	4.5-6.0 (0.45-0.6, 3.3-4.3)	5 mm screw	3.5-5.0 (0.35-0.5, 2.5-3.6)
6 mm bolt, nut	8-12 (0.8-1.2, 6-9)	6 mm screw, SH bolt	7-11 (0.7-1.1, 5-8)
8 mm bolt, nut	18-25 (1.8-2.5, 13-18)	6 mm flange bolt, nut	10-14 (1.0-1.4, 7-10)
10 mm bolt, nut	30-40 (3.0-4.0, 22-29)	8 mm flange bolt, nut	24-30 (2.4-3.0, 17-22)
12 mm bolt, nut	50-60 (5.0-6.0, 36-43)	10 mm flange bolt, nut	35-45 (3.5-4.5, 25-32)

TOOLS

SPECIAL

DESCRIPTION	TOOL NUMBER	ALTERNATIVE TOOL	TOOL NUMBER	REF. PAGE
Lock nut wrench, 56 mm	07916-HA20000	Lock nut wrench, 56 mm (U.S.A. only)	07916-HA2010A	12-4, 12-7
Lock nut wrench, 45 mm	07916-1870101	Commercially available in U.S.A.		12-4, 12,7
Universal bearing puller	07631-0010000	Commercially available in U.S.A.		10-11
Steering stem socket	07916-3710100			11-22, 11-24
Hex wrench, 6 mm	07917-3230000	Commercially available in U.S.A.		11-15, 11-18
Clutch center holder	07923-KE10000	Not available in U.S.A.		8-7, 8-9
Snap ring pliers	07914-3230001	Commercially available in U.S.A.		11-16, 11-19, 14-19, 14-21
Assembly collar	07931-VM00100	Assembly collar	07931-KF00100	10-13
Thread adaptor	07931-KF00200	Assembly collar	07931-HA50100	10-13
Shaft puller	07931-ME40000			10-13
Bearing remover, 17 mm	07936-3710300			10-7, 10-12
Remover handle	07936-3710100			10-7, 10-12
Remover weight	07741-0010201	Remover weight	07936-3710200	10-7, 10-12
Ball race driver	07946-3290000			11-23
Steering stem driver	07946-4300101	Steering stem driver Attachment (U.S.A. only)	07946-MB00000 GN-HT-54	11-23
Ball race remover	07953-3330000			11-22
Valve guide reamer	07984-200000			6-8
Needle bearing remover	07946-KA50000	Driver	07749-0010000	13-11
		Attachment, 32 x 35 mm	07746-0010100	
		Pilot, 20 mm (U.S.A. only)	07746-0040500	
Needle bearing remover	07931-MA70000	Bushing remover and common drift (U.S.A. only)	M967X-038- XXXXX	13-11
Fork seal driver	07947-KA50100			11-19
Fork seal driver attachment	07947-KL40100	Fork seal driver	07947-3710101	11-19
Gear holder	07724-0010100			8-13, 8-14
Universal bead breaker	GN-AH-958-BB1	U.S.A. only		11-10

GENERAL INFORMATION

COMMON

DESCRIPTION	TOOL NUMBER	ALTERNATIVE TOOL	TOOL NUMBER	REF. PAGE
Float level gauge	07401--0010000			4-7
Valve adjusting wrench, 10 x 12 mm	07708--0030200	Equivalent tool commercially available in U.S.A.		3-6
Valve adjuster	07708--0030400	Valve adjuster	89201--200--000	3-6
Lock nut wrench, 17 x 27 mm	07716--0020300	Commercially available in U.S.A.		8-7, 8-9, 8-14
Lock nut wrench, 30 x 32 mm	07716--0020400	Commercially available in U.S.A.		11-21, 11-24
Extention	07716--0020500	Commercially available in U.S.A.		8-7, 8-9, 11-21, 11-24
Flywheel holder	07725--0040000	Strap wrench commercially available in U.S.A.		9-3, 9-4
Rotor puller	07733--0020001	Rotor puller	07933--3950000	9-4
Valve guide remover, 5.5 mm	07742--0010100	Valve guide remover	07942--3290100	6-8
Attachment, 24 x 26 mm	07746--0010700			8-5
Attachment, 37 x 40 mm	07746--0010200			10-7, 10-11, 10-12
Pilot, 15 mm	07746--0040300			11-8
Attachment, 42 x 47 mm	07746--0010300			10-5, 10-8, 11-8
Pilot, 20 mm	07746--0040500			8-5, 10-8
Pilot, 22 mm	07746--0041000			10-8
Attachment, 52 x 55 mm	07746--0010400			10-8
Attachment, 62 x 68 mm	07746--0010500			12-10
Pilot, 40 mm	07746--0040900			12-10
Attachment, 72 x 75 mm	07746--0010600			10-13, 10-14
Driver	07749--0010000			
Valve spring compressor	07757--0010000	Valve spring compressor	07957--3290001	6-7, 6-12
Pin driver, 3 mm	07744--0010200			8-4, 8-19
Bearing remover expander	07746--0050100	Commercially available in U.S.A.		11-7
Bearing remover collet, 15 mm	07746--0050400			11-7
Tire breaker set	07772--0050000			
—Breaker arm compressor	07772--0050100	Not available in U.S.A.		11-11
—Breaker arm	07772--0050200			
Kowa digital multi tester	07411--0020000	Digital multi tester Sanwa electric tester Kowa electric tester	KS-AHM-32-003 07308--0020000 TH-5H	16-4

VALVE SEAT CUTTERS

Valve seat cutters are commercially available in the U.S.A. Therefore, the following cutters are not required in the U.S.A.

DESCRIPTION	TOOL NUMBER	REF. PAGE
Valve seat cutter, 29 mm (EX 45°)	07780--0010300	6-9
Valve seat cutter, 33 mm (IN 45°)	07780--0010800	6-9
Valve seat cutter, 30 mm (EX 32°)	07780--0012200	6-9
Valve seat cutter, 35 mm (IN 32°)	07780--0012300	6-9
Valve seat cutter, 30 mm (EX 60°)	07780--0014000	6-9
Valve seat cutter holder, 5.5 mm	07781--0010101	6-9

CABLE & HARNESS ROUTING

Note the following when routing cables and wire harnesses:

- A loose wire, harness or cable can be a safety hazard. After clamping, check each wire to be sure it is secure.
- Do not squeeze wires against the weld or end of a clamp when a weld-on clamp is used.
- Secure wires and wire harnesses to the frame with their respective wire bands at the designated locations. Tighten the bands so that only the insulated surfaces contact the wires or wire harnesses.
- Route harnesses so they are not pulled tight or have excessive slack.
- Protect wires and harnesses with electrical tape or tubing if they are in contact with a sharp edge or corner. Clean the attaching surface thoroughly before applying tape.
- Do not use wires or harnesses with broken insulators. Repair by wrapping them with protective tape or replace them.
- Route wire harnesses to avoid sharp edges or corners. Also avoid the projected ends of bolts and screws.
- Keep wire harnesses away from the exhaust pipes and other hot parts.
- Be sure grommets are seated in their grooves properly.
- After clamping, check each harness to be certain that it does not interfere with any moving or sliding parts.
- Wire harnesses routed along the handlebars should not be pulled tight, have excessive slack, be pinched, or interfere with adjacent or surrounding parts in all steering positions.
- After routing, check that the wire harnesses are not twisted or kinked.

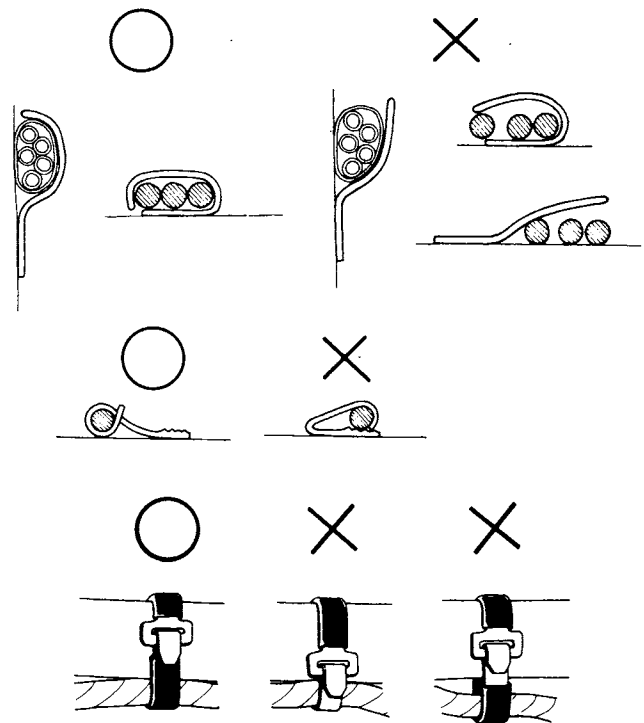

O : CORRECT
X : INCORRECT

GENERAL INFORMATION

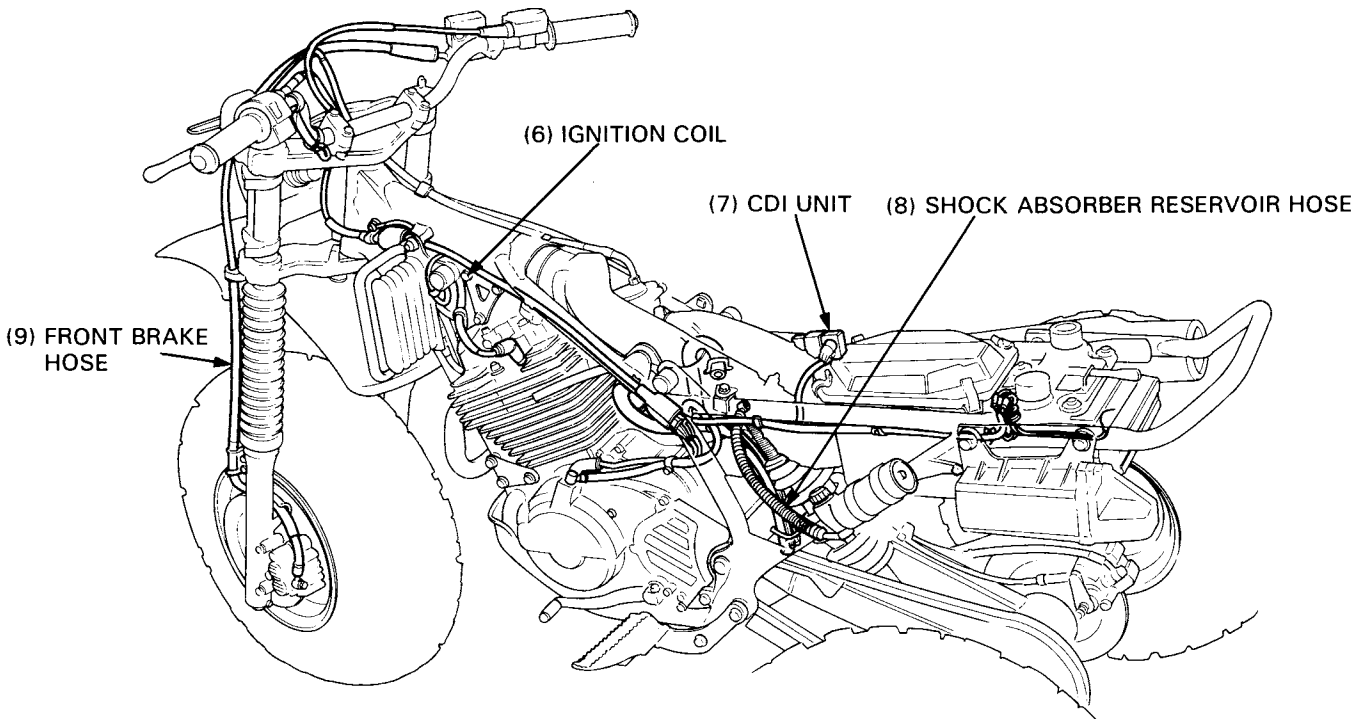
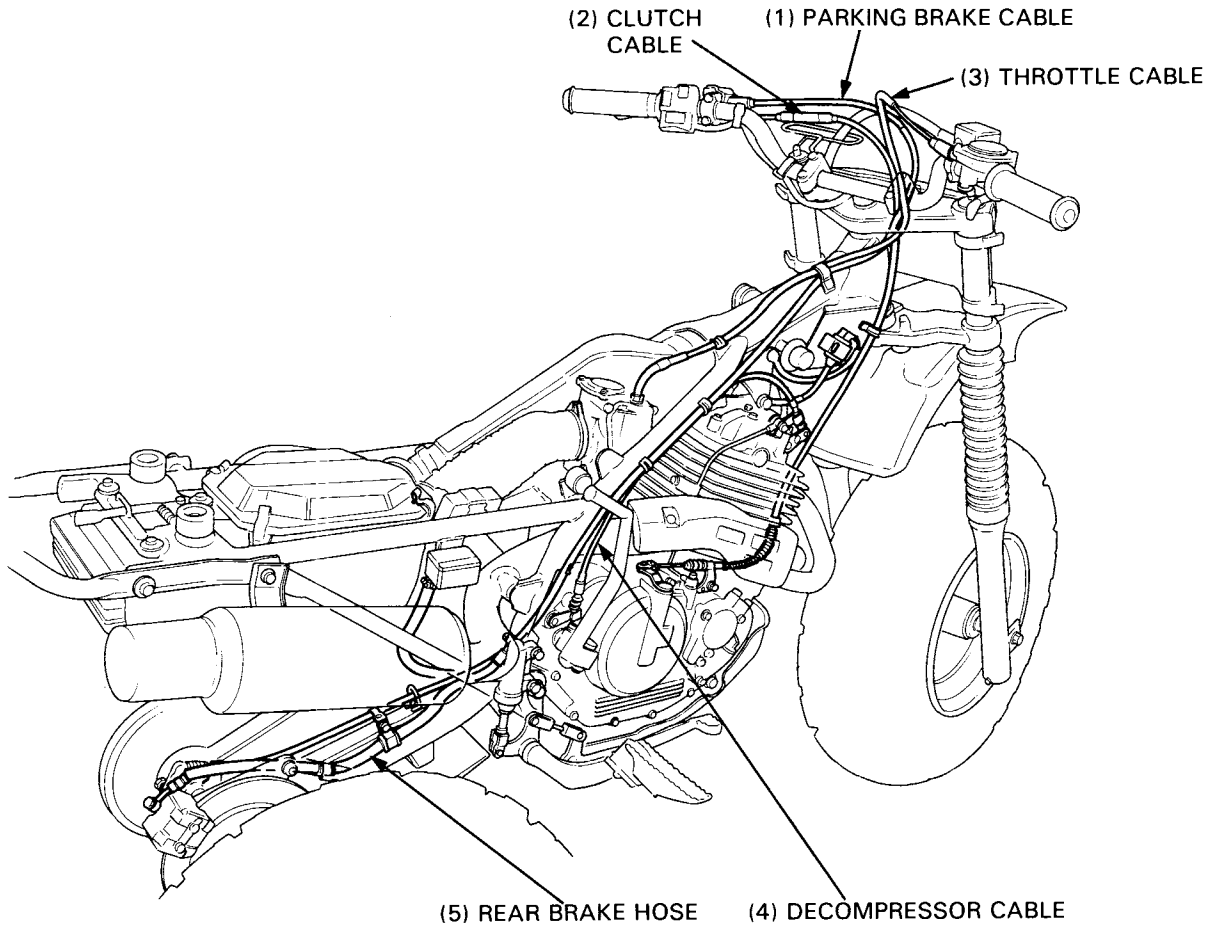

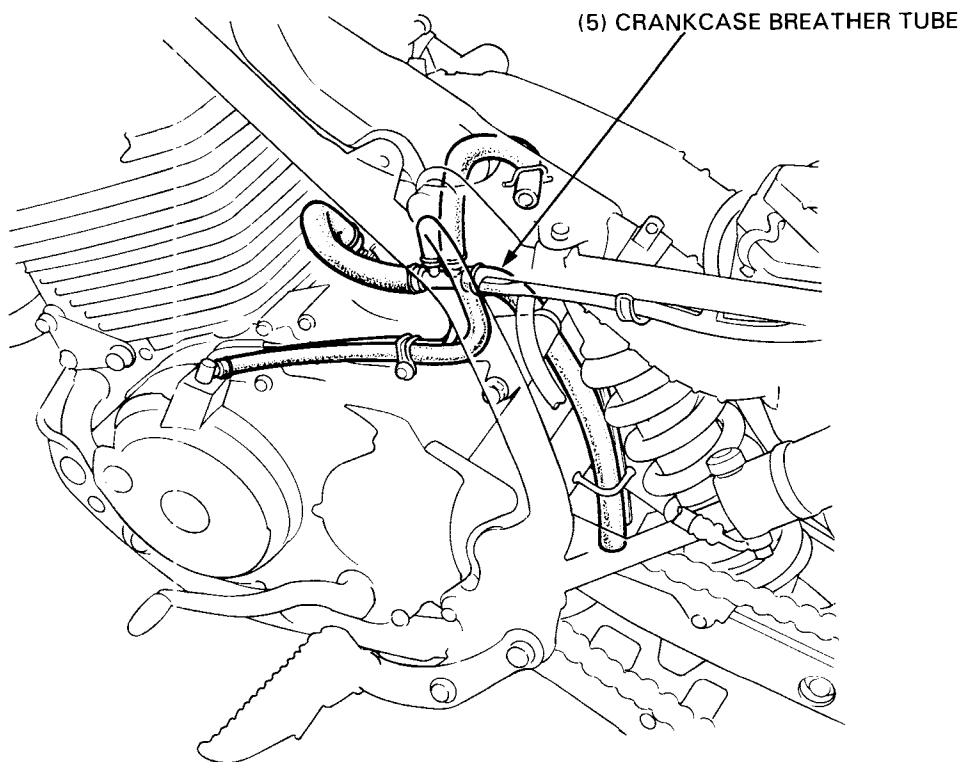
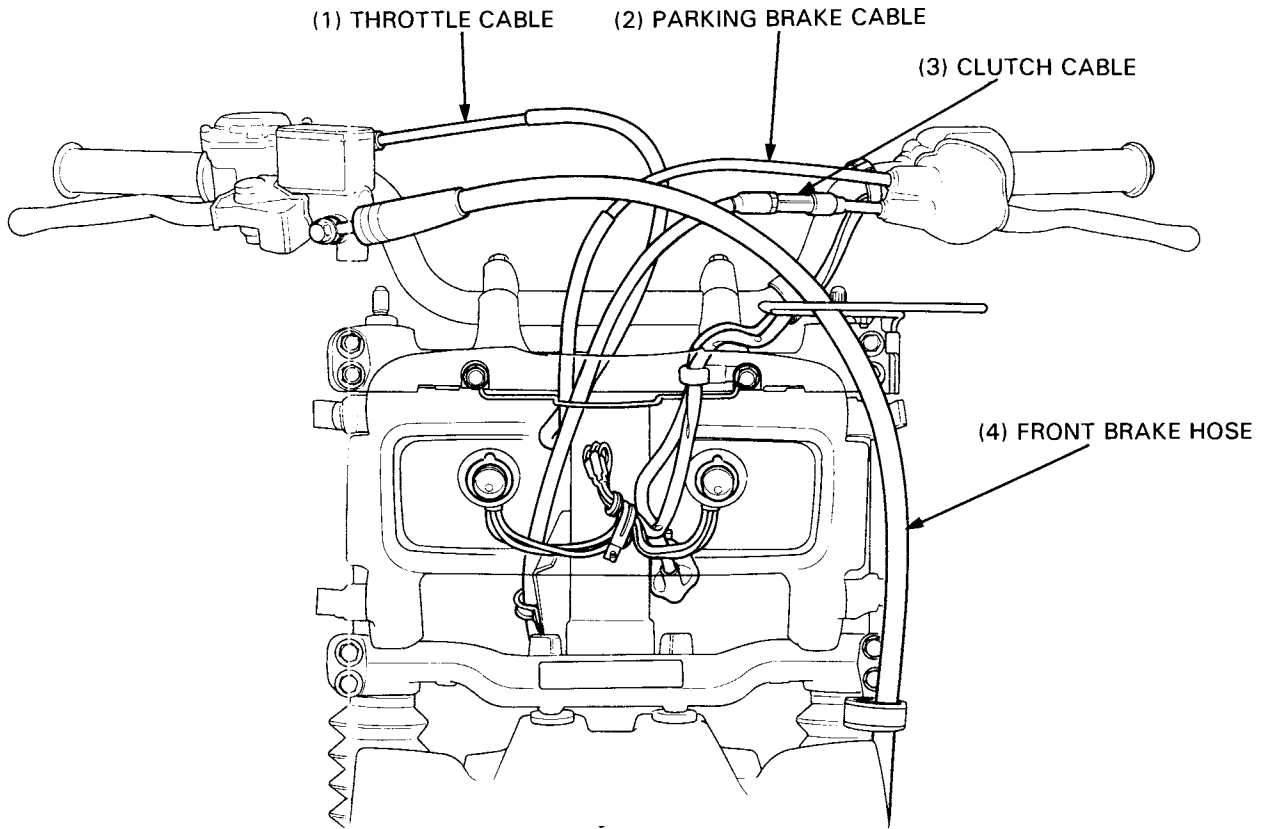

GENERAL INFORMATION

AFTER '85:

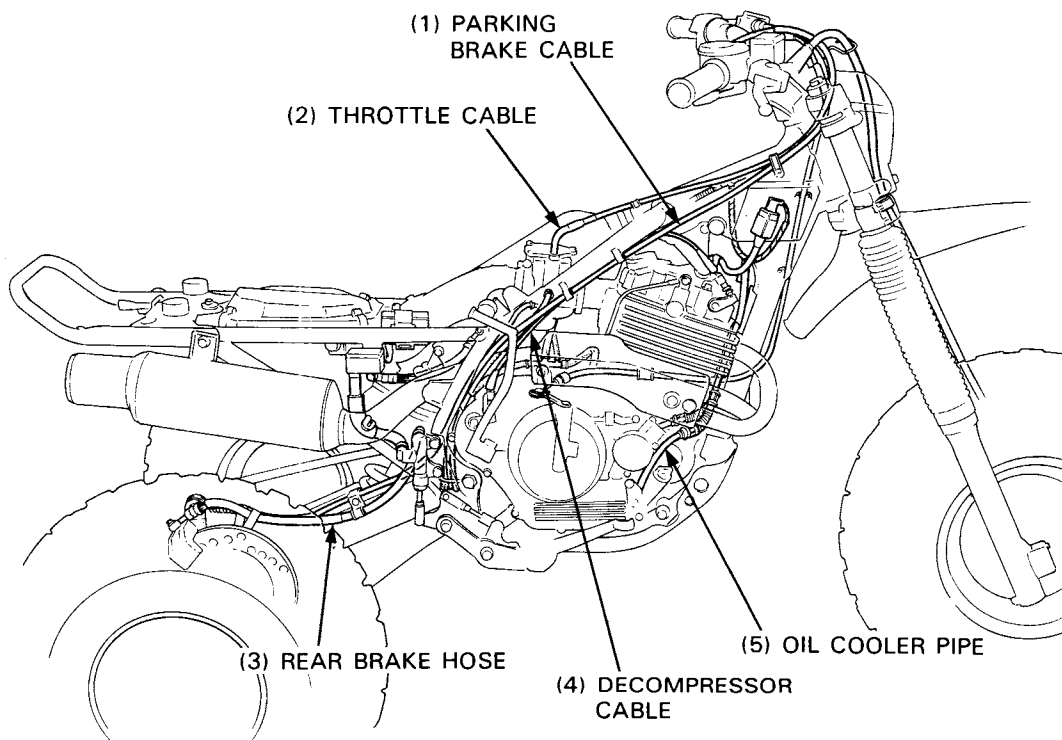
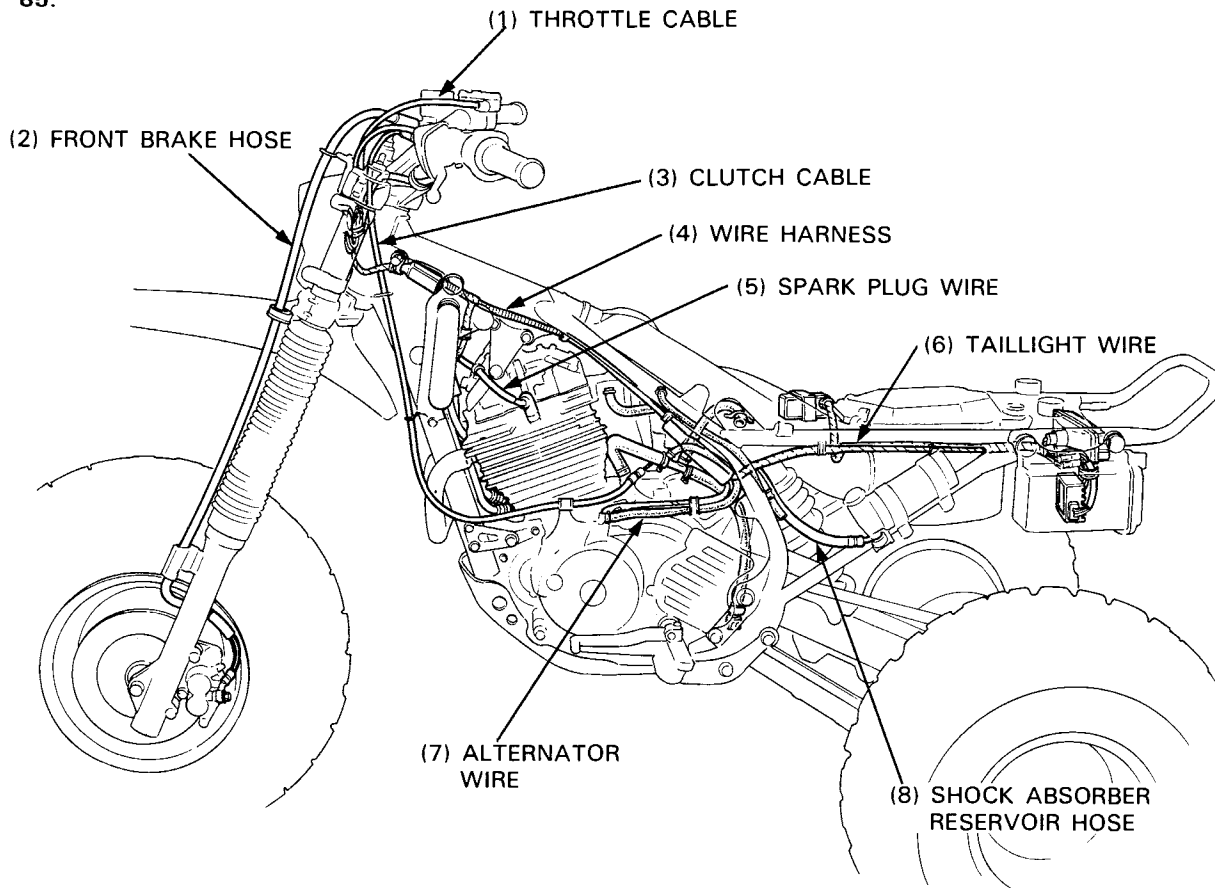

NOISE EMISSION CONTROL SYSTEM (U.S.A. only)

The U.S. Environmental Protection Agency requires manufacturers to certify that vehicles built after January 1, 1983 will comply with applicable noise emission standards for one year or 1,865 miles (3,000 km) after the time of sale to the ultimate purchaser, when operated and maintained according to the instructions provided. Compliance with the terms of the Distributor's Warranty for the Honda Vehicle Noise Emission Control System is necessary in order to keep the noise emission control system in effect.

TAMPERING WITH THE NOISE CONTROL SYSTEM IS PROHIBITED: Federal law prohibits the following acts or the causing thereof: (1) The removal or rendering inoperative by any person, other than for purposes of maintenance, repair, or replacement, of any device or element of design incorporated into any new vehicle for the purpose of noise control prior to its sale or delivery to the ultimate purchaser or while it is in use; or (2) the use of the vehicle after such device or element of design has been removed or rendered inoperative by any person.

AMONG THOSE ACTS PRESUMED TO CONSTITUTE TAMPERING ARE THE ACTS LISTED BELOW:

1. Removal of, or puncturing the muffler, baffle, header pipes or any other component which conducts exhaust gases.
2. Removal of, or puncturing of any parts of the intake system.
3. Lack of proper maintenance.
4. Replacing any moving parts of the vehicle, or parts of the exhaust or intake system, with parts other than those specified by the manufacturer.

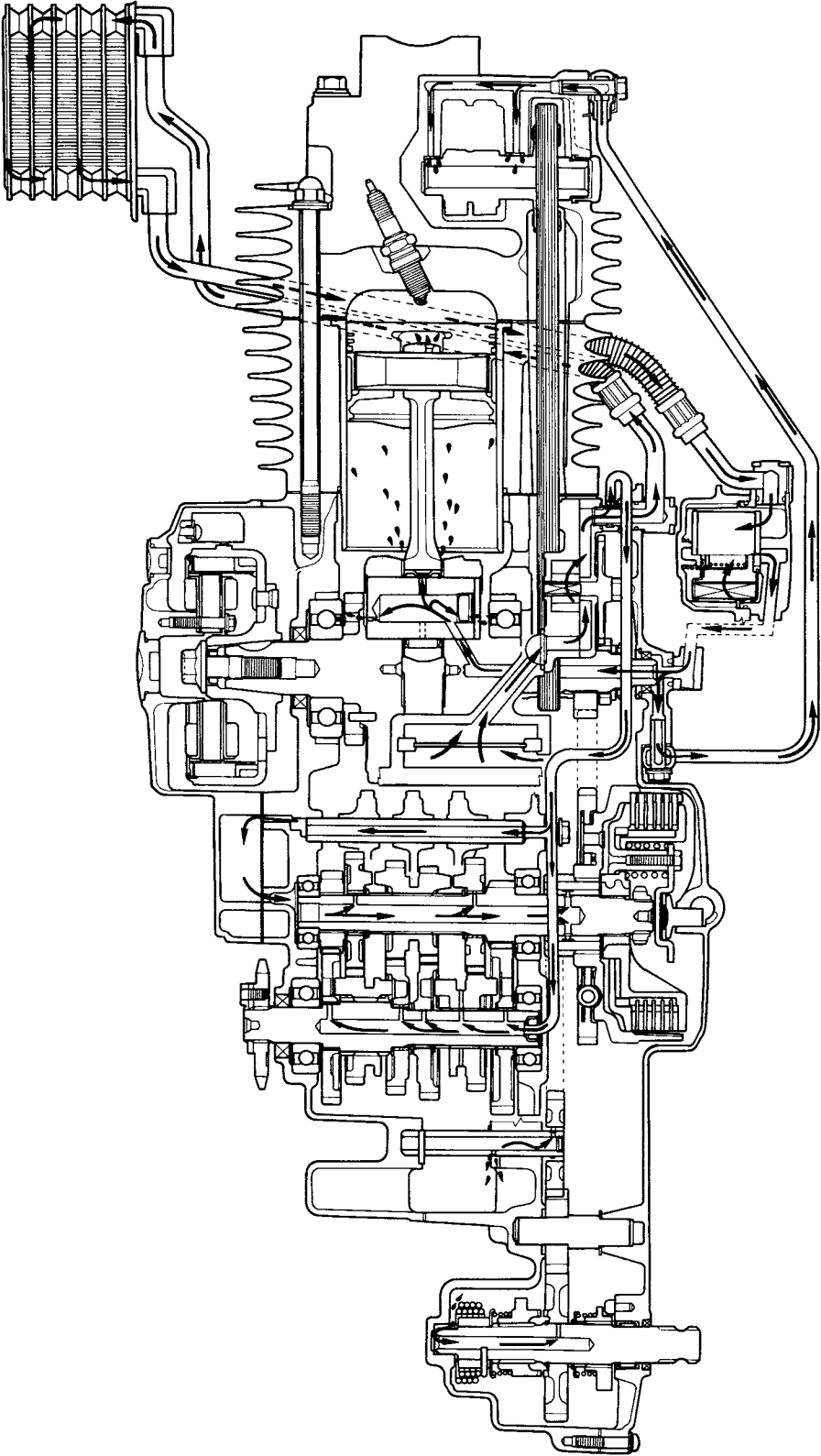

2. LUBRICATION

SERVICE INFORMATION	2-1	ENGINE OIL & FILTER CHANGE	2-2
TROUBLESHOOTING	2-1	OIL COOLER	2-3
ENGINE OIL LEVEL	2-2	LUBRICATION POINTS	2-4

SERVICE INFORMATION

GENERAL

- Section 8 shows how to service the oil filter screen and oil pump.

SPECIFICATIONS

Engine oil capacity 2.3 liters (2.43 US qt, 2.03 Imp qt) at disassembly
 1.8 liters (1.91 US qt, 1.59 Imp qt) after draining

Engine oil recommendation Use Honda 4-stroke oil or equivalent.
 API Service Classification: SE or SF
 Viscosity: SAE 10W-40
 Other viscosities shown in the chart may be used when the average temperature in your riding area is within the indicated range.

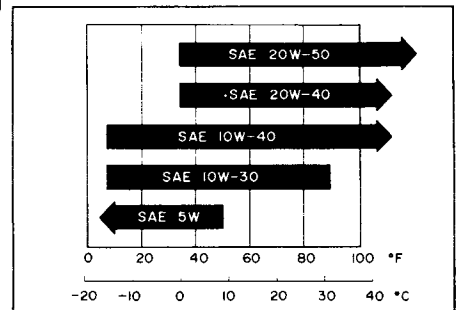

TORQUE VALUE

Oil drain plug '85: 15-25 N·m (1.5-2.5 kg-m, 11-18 ft-lb)
 After '85: 20-30 N·m (2.0-3.0 kg-m, 14-22 ft-lb)

TROUBLESHOOTING

Oil level too low — high oil consumption

- Normal oil consumption.
- External oil leaks.
- Worn piston rings.
- Oil not changed often enough.
- Faulty head gasket.

Oil contamination

- Oil or filter not changed often enough.
- Head gasket faulty.
- Worn piston rings.

LUBRICATION

ENGINE OIL LEVEL

Place the ATC on level ground.
Check the oil level with the oil filler cap/dipstick.
Do not screw it in when making this check.

If the oil level is below or near the lower level line on the dipstick, add the recommended oil (page 2-1) up to the upper level line.

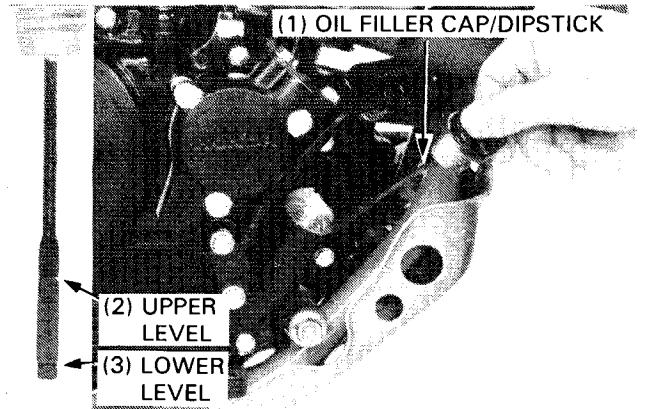

ENGINE OIL & FILTER CHANGE

NOTE

- Drain the oil with the engine warm.
- The oil filter screen and spring will come out when the oil filter screen cap is removed.

Remove the oil filler cap and drain plug and drain the oil.
Remove the two bolts and disconnect the oil cooler pipe from the oil filter cover.

Remove the three bolts attaching the oil filter cover, and remove the cover, oil filter and spring.

Discard the oil filter.

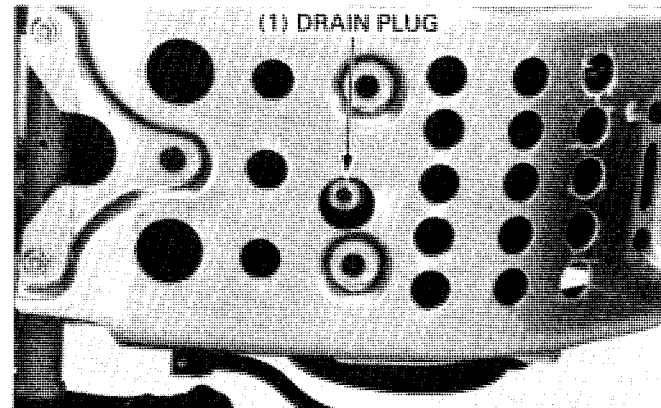

Check that the sealing washer on the drain plug is in good condition and install the drain plug.

TORQUE:

'85: 15–25 N·m (1.5–2.5 kg-m, 11–18 ft-lb)

After '85: 20–30 N·m (2.0–3.0 kg-m, 14–22 ft-lb)

Make sure that the O-ring on the oil filter cover and oil cooler pipe are in good condition.

Install the oil filter spring, a new filter and the cover and tighten the cover with the three bolts.

TORQUE: 8–12 N·m (0.8–1.2 kg-m, 6–9 ft-lb)

Connect the oil cooler pipe to the oil filter cover using the two bolts.

Fill the crankcase with 1.8 liters (1.91 US qt, 1.59 Imp qt) of the recommended oil (page 2-1).

Install the oil filler cap/dipstick.

Start the engine and let it idle for 2 or 3 minutes.

Stop the engine and check that the oil level is at the upper level line on the dipstick. Add more oil if necessary.

Make sure there are no oil leaks.

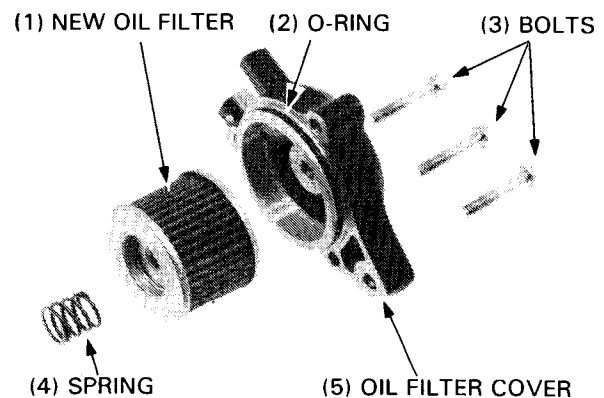
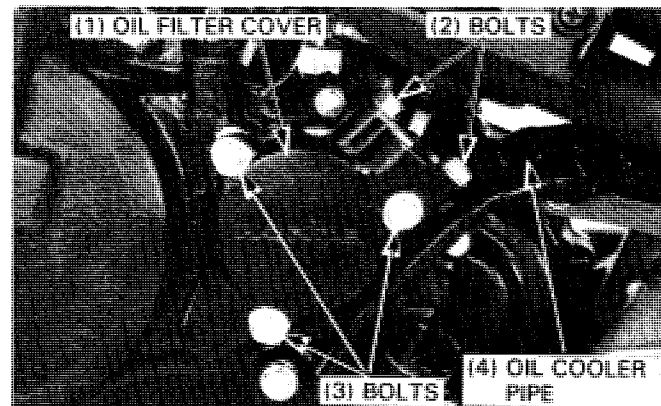

OIL COOLER

INSPECTION

Check the oil cooler air passage for clogging or damage. Straighten bent fins and collapsed core tubes. Remove insects, mud or any obstruction with compressed air or low water pressure.

Replace the oil cooler if the air flow is restricted over more than 20% of the radiating surface.

Also inspect the oil cooler inlet and outlet pipes for cracks or deterioration, and replace if necessary. Check the tightness of both pipe connections.

REMOVAL

Remove the fuel tank (page 4-3).
Drain the engine oil (page 2-2).

Remove the four bolts and disconnect the oil cooler pipes from the right crankcase cover.

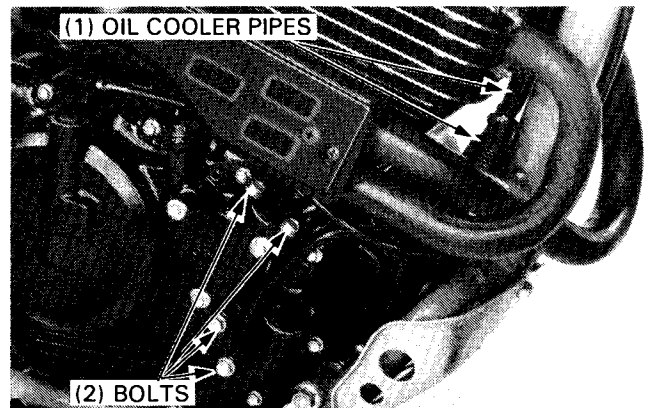
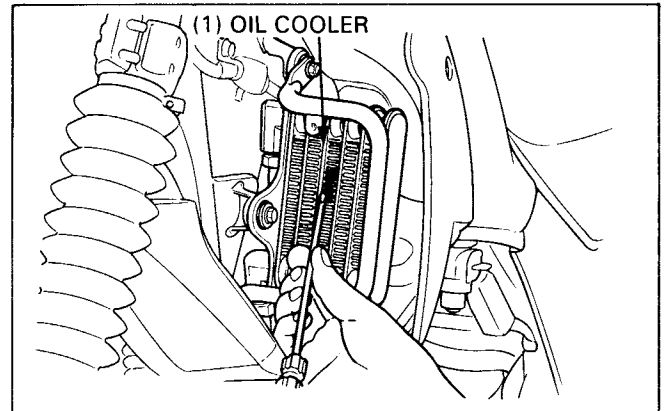

Remove the two oil cooler mounting bolt, nuts, oil cooler guard and the oil cooler.

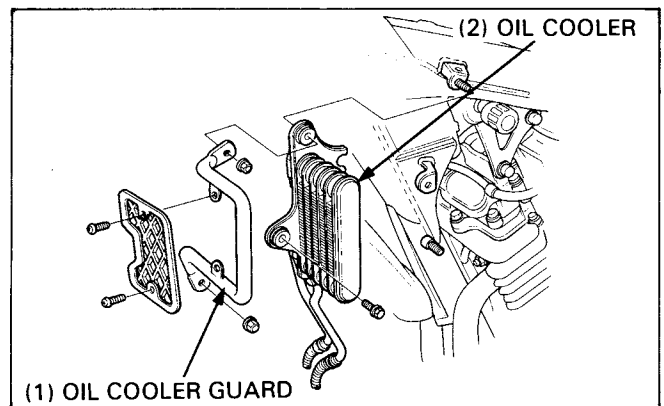

INSTALLATION

Make sure that the O-rings on the ends of the pipes are in good condition.

Install the oil cooler in the reverse order of removal.

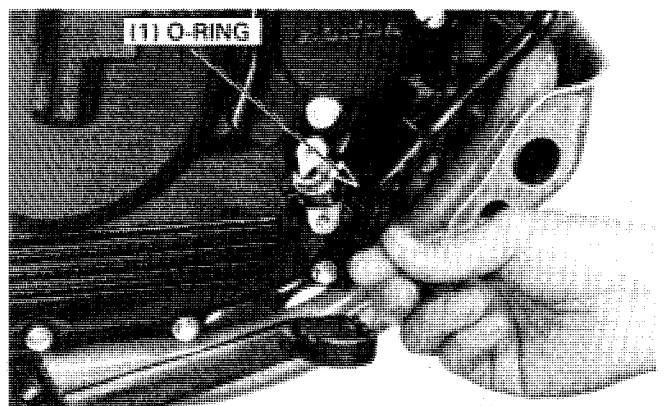

LUBRICATION

LUBRICATION POINTS

Use general purpose grease when no other specification is given. Apply oil or grease to any 2 sliding surfaces.

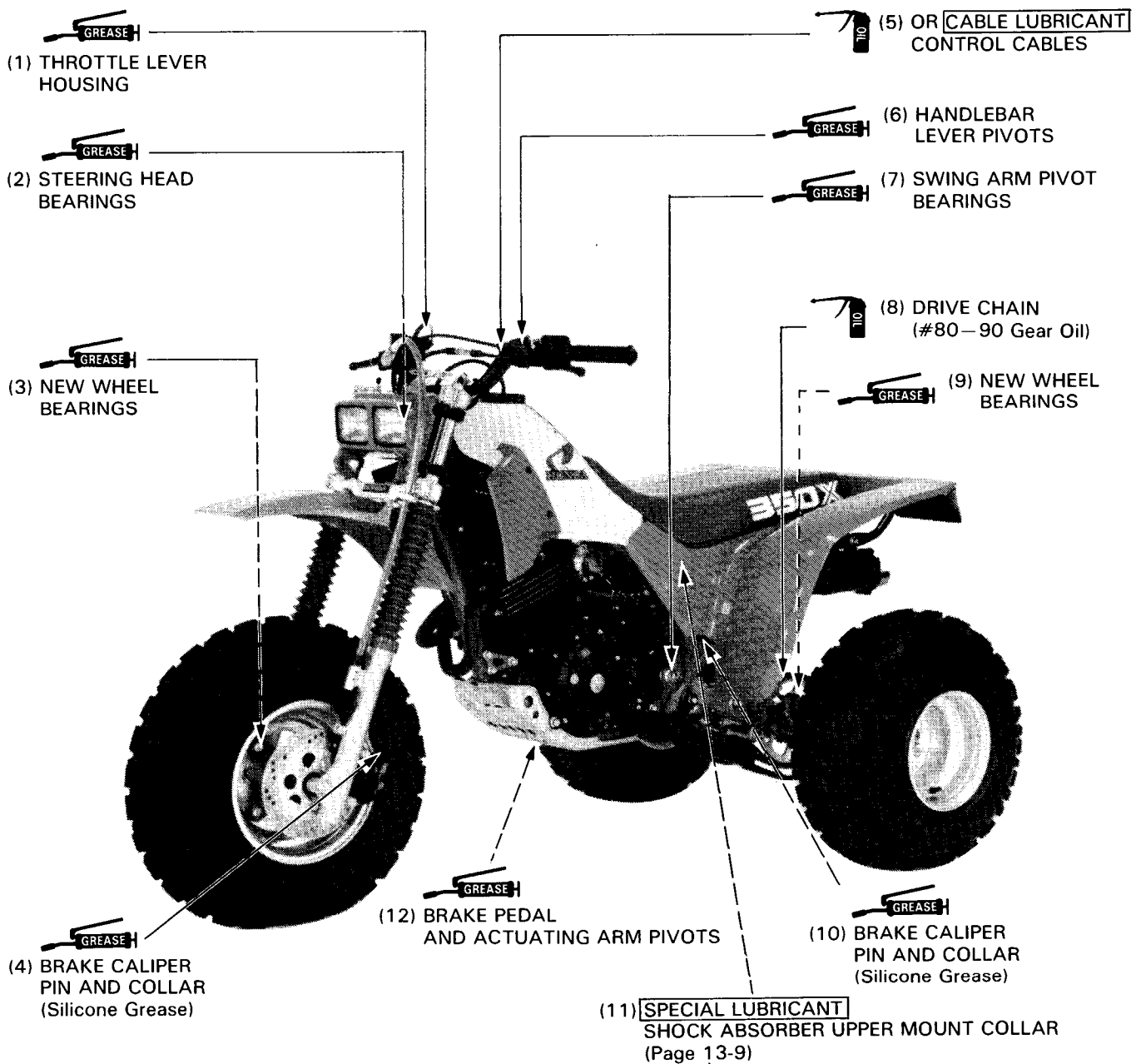

3. MAINTENANCE

3

SERVICE INFORMATION	3-1	DRIVE CHAIN	3-10
MAINTENANCE SCHEDULES	3-2	DRIVE CHAIN SLIDER	3-11
AIR CLEANER	3-4	SUSPENSION	3-11
AIR CLEANER CASE BREATHER	3-4	BRAKE PADS	3-12
CRANKCASE BREATHER	3-5	BRAKE FLUID	3-13
SPARK PLUG	3-5	BRAKE SYSTEM	3-13
VALVE CLEARANCE	3-5	REAR BRAKE PIVOTS	3-15
CARBURETOR-IDLE SPEED	3-6	CLUTCH	3-16
FUEL LINE	3-7	SPARK ARRESTER	3-16
FUEL STRAINER SCREEN	3-7	NUTS, BOLTS, FASTENERS	3-17
THROTTLE OPERATION	3-7	WHEELS/TIRES	3-17
IGNITION TIMING	3-8	STEERING HEAD BEARINGS	3-18
CYLINDER COMPRESSION	3-9		

SERVICE INFORMATION

SPECIFICATIONS

ENGINE

Ignition timing	Initial	10° BTDC
	Full advance	30° BTDC
Spark plug	Spark plug gap	0.6–0.7 mm (0.024–0.028 in)
	Recommended spark plugs	NGK DR8ES–L ND X24ESR-U
Valve clearance	IN	0.08 mm (0.003 in)
	EX	0.08 mm (0.003 in)
Throttle lever free play		3–8 mm (1/8–5/16 in)
Idle speed		1,400 ± 100 rpm
Cylinder compression		1,250 ± 100 kPa (12.5 ± 1.0 kg/cm ² , 178 ± 14.2 psi)
Decompressor cam follower shaft arm free play		0.5–1.5 mm (1/14 in)

CHASSIS

Drive chain slack	35–45 mm (1-3/8–1-3/4 in)
Drive chain slider wear limit	6 mm (0.24 in)
Parking brake lever free play	31–39 mm (1-3/16–1-1/2 in)
Clutch lever free play	10–20 mm (3/8–3/4 in)
Front tire size, pressure	23.5 x 8–11, 28 kPa (0.28 kg/cm ² , 4.0 psi)
Rear tire size, pressure	22.0 x 10–9, 21 kPa (0.21 kg/cm ² , 3.0 psi)
Front tire circumference	1,901 mm (74.8 in)
Rear tire circumference	1,734 mm (68.3 in)
Front suspension air pressure	0 kPa (0 kg/cm ² , 0 psi)

TORQUE VALUES

Fuel strainer cup	3–5 N·m (0.3–0.5 kg-m, 2.2–3.6 ft-lb)
Drive chain adjuster lock bolts	'85: 13–18 N·m (1.3–1.8 kg-m, 9–13 ft-lb) After '85: 18–25 N·m (1.8–2.5 kg-m, 13–18 ft-lb)
Valve adjusting lock nuts	15–18 N·m (1.5–1.8 kg-m, 11–13 ft-lb)
Parking brake adjusting lock nut	15–20 N·m (1.5–2.0 kg-m, 11–15 ft-lb)

TOOLS

Common

Valve adjusting wrench, 10 x 12 mm	07708–0030200 or equivalent commercially available in U.S.A.
Valve adjuster	07708–0030400 or 89201–200–000 (U.S.A. only)

MAINTENANCE

MAINTENANCE SCHEDULES

'85:

- The maintenance intervals shown in the following schedule are based upon average riding conditions. ATC's subjected to severe use, or ridden in unusually dusty areas, require more frequent servicing.

Perform the Pre-ride Inspection in the Owner's Manual at each scheduled maintenance period.

	I: Inspect and Clean, Adjust, Lubricate or Replace, if necessary C: Clean R: Replace L: Lubricate	EVERY	INITIAL	REGULAR	Refer to page
			SERVICE PERIOD (First week of operation)	SERVICE PERIOD (Every 30 operating days)	
	ENGINE OIL		R	R	2-2
	ENGINE OIL FILTER		R	R	2-2
	AIR CLEANER	NOTE 1		C	3-4
	SPARK PLUG			I	3-5
*	VALVE CLEARANCE		I	I	3-5
*	CARBURETOR-IDLE SPEED		I	I	3-6
	FUEL LINE	YEAR I			3-7
*	FUEL STRAINER SCREEN	YEAR C			3-7
*	THROTTLE OPERATION		I	I	3-7
	DRIVE CHAIN	NOTE 1	I,L	I,L	3-9
	DRIVE CHAIN SLIDER			I	3-11
*	SUSPENSION			I,L	3-11
*	BRAKE PADS	YEAR I			3-12
	BRAKE FLUID	2 YEARS R		I	3-13
	BRAKE SYSTEM		I	I	3-13
*	CLUTCH		I	I	3-16
*	SPARK ARRESTER	NOTE 3		C	3-16
	NUTS, BOLTS, FASTENERS		I	I	3-17
**	WHEELS/TIRES		I	I	3-17
**	STEERING HEAD BEARINGS	YEAR I			3-18
**	REAR BRAKE PIVOTS	YEAR I			3-14

* Should be serviced by an authorized Honda dealer, unless the owner has proper tools and service data and is mechanically qualified.

** In the interest of safety, we recommend these items be serviced ONLY by an authorized HONDA dealer.

NOTES: 1. Service more frequently when riding in dusty areas.
2. Service more frequently after riding in very wet or muddy conditions.
3. U.S.A. only

After '85:

- The maintenance intervals shown in the following schedule are based upon average riding conditions. ATC's subjected to severe use, or ridden in unusually dusty areas, require more frequent servicing.

Perform the Pre-ride Inspection in the Owner's Manual at each scheduled maintenance period.

I: Inspect and Clean, Adjust, Lubricate or Replace, if necessary C: Clean R: Replace L: Lubricate		EVERY	INITIAL SERVICE PERIOD (First week of operation)	REGULAR SERVICE PERIOD (Every 30 operating days)	Refer to page
*	FUEL LINE	YEAR: I			3-7
*	FUEL STRAINER SCREEN	YEAR: C			3-7
*	THROTTLE OPERATION		I	I	3-7
	AIR CLEANER	NOTE 1		C	3-4
	AIR CLEANER CASE BREATHER	NOTE 2		C	3-4
	CRANKCASE BREATHER			I	3-5
	SPARK PLUG			I	3-5
*	VALVE CLEARANCE		I	I	3-5
	ENGINE OIL		R	R	2-2
	ENGINE OIL FILTER		R	R	2-2
*	CARBURETOR-IDLE SPEED		I	I	3-6
	DRIVE CHAIN	NOTE 1	I,L	I,L	3-9
	DRIVE CHAIN SLIDER			I	3-11
	BRAKE FLUID	2 YEARS: R		I	3-13
*	BRAKE PAD WEAR	YEAR: I NOTES 1, 2			3-12
	BRAKE SYSTEM		I	I	3-13
*	CLUTCH SYSTEM		I	I	3-16
*	SUSPENSION			I	3-11
*	SPARK ARRESTER	NOTE 3		C	3-16
	NUT, BOLT, FASTENER		I	I	3-17
**	WHEELS		I	I	3-17
**	STEERING HEAD BEARING	YEAR: I			3-18

* Should be serviced by an authorized Honda dealer, unless the owner has proper tools and service data and is mechanically qualified.

** In the interest of safety, we recommend these items be serviced ONLY by an authorized HONDA dealer.

- NOTES: 1. Service more frequently when riding in dusty areas, sand or snow.
 2. Service more frequently after riding in very wet or muddy conditions.
 3. U.S.A. only

MAINTENANCE

AIR CLEANER

Remove the seat/rear fender.

Release the four clips retaining the air cleaner cover.
Remove the air cleaner cover.



Remove the element band and remove the element and holder.

Remove the element from the holder.

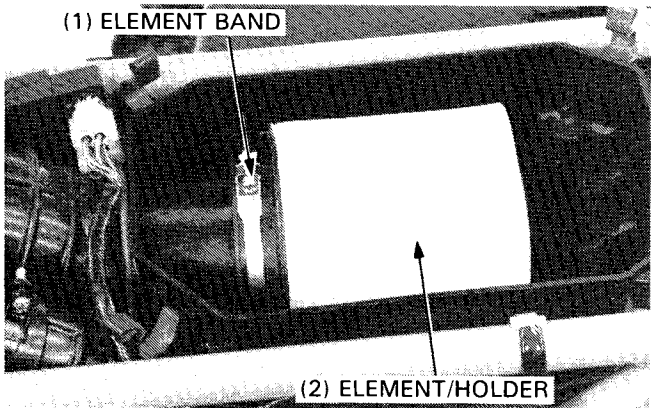

Wash the element in non-flammable or high flash point solvent, squeeze out the solvent thoroughly, and allow to dry.

Soak the element in gear oil (SAE 80–90) and squeeze out excess.

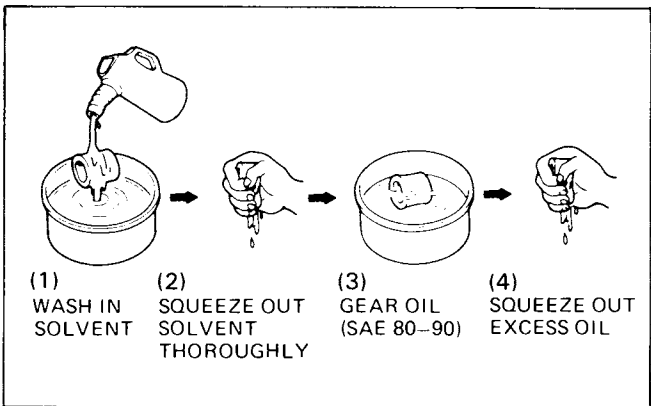

Reinstall the element on the holder and apply a light coat of grease to the sealing edge of the element.

Install the element/holder into the case so that its front end contacts the ridge as shown and secure it with the band.

Reinstall the air cleaner cover and the seat/rear fender.

AIR CLEANER CASE BREATHER

Press the end of the drain valve and drain the deposit from the air cleaner case.

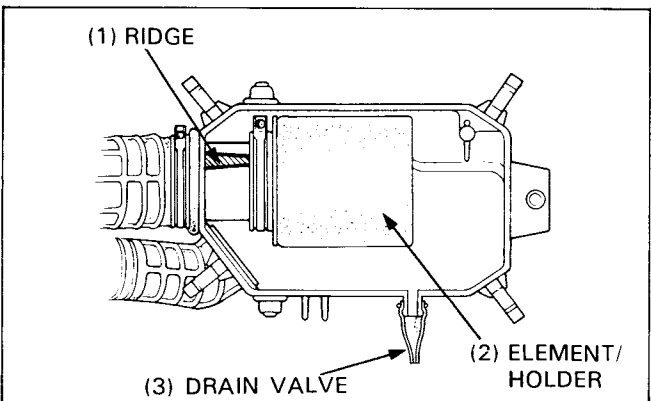

CRANKCASE BREATHER

Press the end of the drain valve and drain the deposit from the drain tube.

SPARK PLUG

Disconnect the spark plug cap and remove the spark plug. Visually inspect the spark plug electrodes for wear. The center electrode should have square edges and the side electrode should have a constant thickness. Discard the spark plug if there is apparent wear or if the insulator is cracked or chipped. Measure the gap with a wire-type feeler gauge and adjust by carefully bending the side electrode.

SPARK PLUG GAP: 0.6–0.7 mm (0.024–0.028 in)

**RECOMMENDED SPARK PLUG: DR8ES–L (NGK)
X24ESR–U (ND)**

Check the sealing washer and replace with a new one if damaged. Install the spark plug, tighten it by hand, then tighten with a spark plug wrench.

NOTE

- Tighten a new spark plug 1/2 turn to compress the washer. If reusing a spark plug, it should only take 1/8–1/4 turn after the plug seats.

Connect the spark plug cap.

VALVE CLEARANCE

NOTE

- Inspect and adjust valve clearance while the engine is cold (below 35°C/95°F).

Remove the seat/rear fender.

Turn the fuel valve OFF and disconnect the fuel tube. Remove the fuel tank.

Remove the crankshaft hole cap and timing mark hole cap.

Remove the valve adjuster covers.

Rotate the crankshaft counterclockwise and align the "T" mark on the generator rotor with the index mark on the left crankcase cover. The piston must be at TDC of the compression stroke (both rocker arms loose).

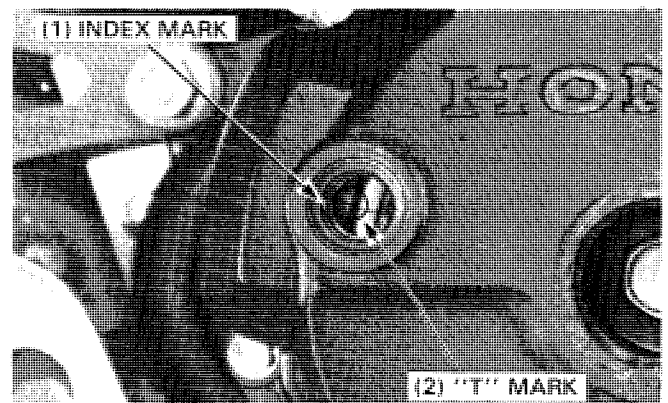
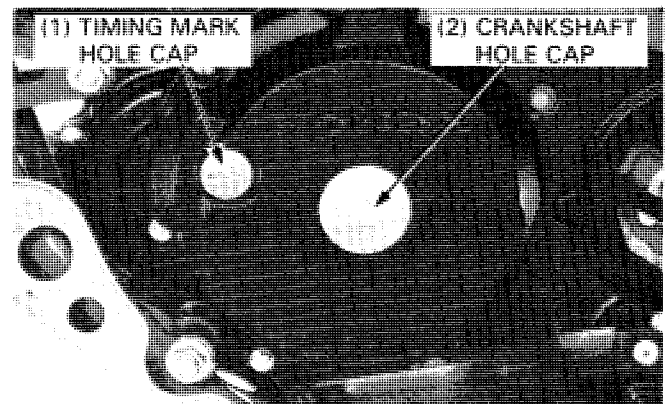
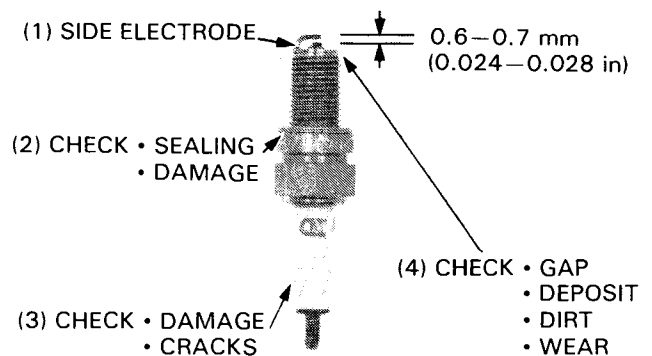
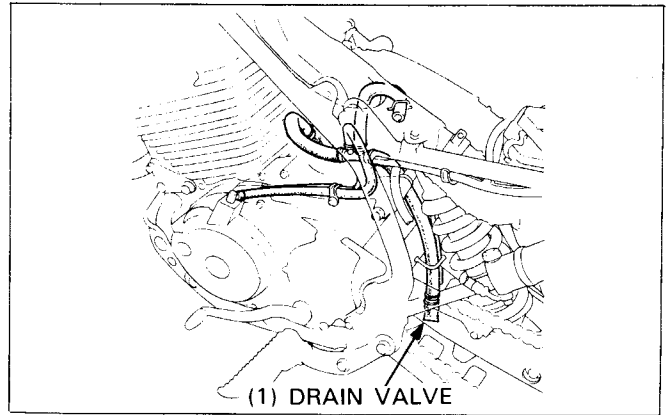

MAINTENANCE

Inspect the intake and exhaust valve clearances by inserting the feeler gauge between the adjusting screw and valve stem.

VALVE CLEARANCES:

INTAKE: 0.08 mm (0.003 in)

EXHAUST: 0.08 mm (0.003 in)

Adjust by loosening the lock nut and turning the adjusting screw until there is a slight drag on the feeler gauge.

Hold the adjusting screw and tighten the lock nut.

TORQUE: 15–18 N·m (1.5–1.8 kg·m, 11–13 ft·lb)

Recheck the valve clearance.

DECOMPRESSOR ADJUSTMENT

NOTE

- Always adjust the decompressor cable after adjusting the valve clearance.

Rotate the flywheel counterclockwise and align the "T" mark with the index mark. Make sure the piston is at TDC on the compression stroke.

Measure the free play at the tip of the decompressor shaft arm.

FREE PLAY: 0.5–1.5 mm (1/14 in)

Adjust by loosening the lock nut and turning the adjusting nut.

CAUTION

- Excessive free play causes hard starting.
- Insufficient free play may cause erratic engine idle and valve damage.

Install the valve adjuster covers, the timing hole cap and crankshaft hole cap.

Install the fuel tank and the seat/rear fender.

Reconnect the fuel tube.

CARBURETOR IDLE SPEED

NOTE

- Inspect and adjust the idle speed after all other maintenance items have been performed and are within specifications.
- The engine must be warm for accurate idle speed inspection and adjustment. Stop and go riding for ten minutes is sufficient.

After warming up the engine, shift the transmission into neutral and connect a tachometer.

Turn the throttle stop screw as required to obtain the specified idle speed.

IDLE SPEED: 1,400 ± 100 rpm

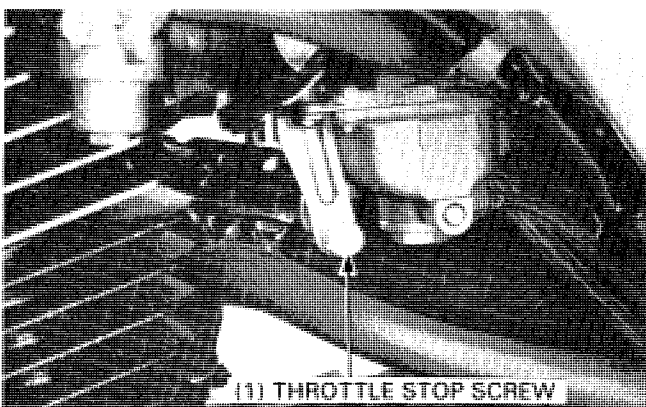
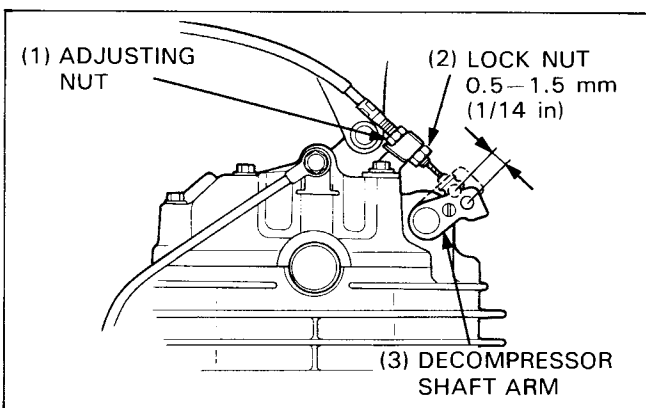
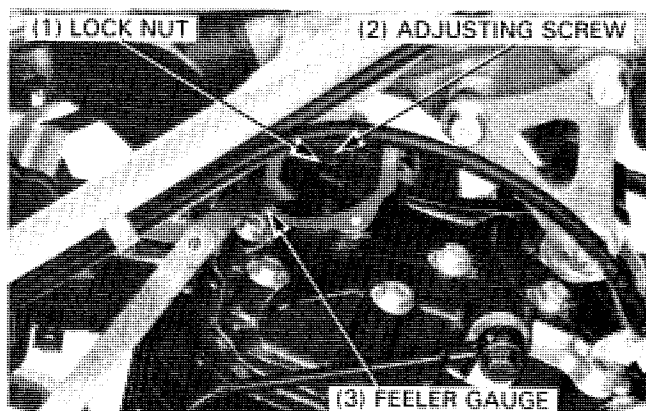

FUEL LINE

Replace any parts which show signs of deterioration, damage or leaks.

FUEL STRAINER SCREEN

Turn the fuel valve OFF.

Remove the fuel cup, O-ring and filter screen, and drain the gasoline into a suitable container.

WARNING

Gasoline is flammable and is explosive under certain conditions. Do not smoke or allow flames or sparks near the equipment while draining fuel.

Wash the cup and filter screen in clean nonflammable or high flash point solvent.

Reinstall the screen, aligning the index marks on the fuel valve body and filter screen.

Install a new O-ring into the fuel valve body.

Reinstall the fuel cup, making sure the new O-ring is in place. Hand tighten the fuel cup and then torque it to specification.

TORQUE: 3–5 N·m (0.3–0.5 kg·m, 2.2–3.6 ft·lb)

CAUTION

- Do not overtighten the fuel cup.

After installing, turn the fuel valve ON and check that there are no fuel leaks.

THROTTLE OPERATION

Check for smooth throttle lever full opening and automatic full closing in all steering positions.

Make sure there is no deterioration, damage or kinking in the throttle cable. Replace any damaged parts.

Remove the throttle housing cover.

Disconnect the throttle cable at the upper end. Thoroughly lubricate the cable and pivot point with a commercially available cable lubricant or grease.

Install the throttle cable in the reverse order of removal.

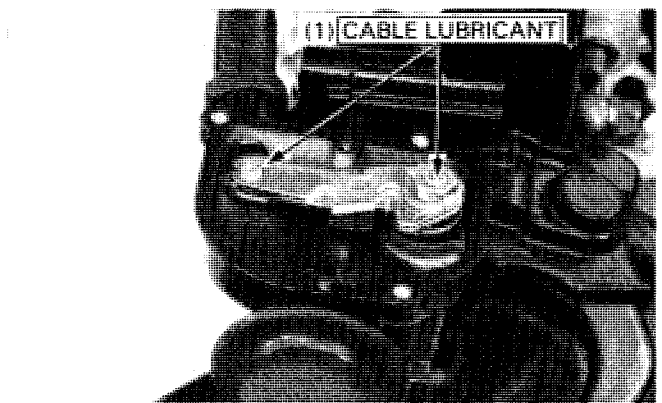
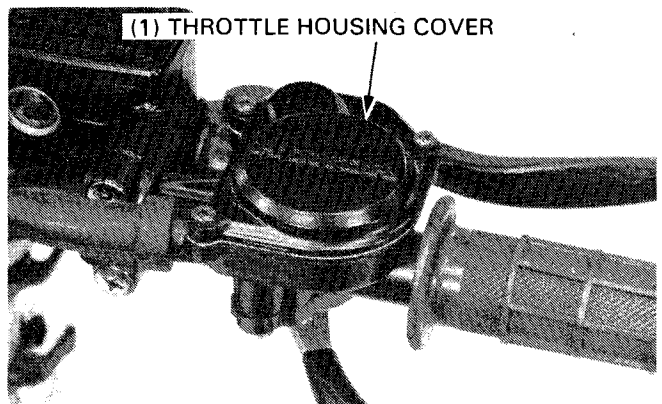
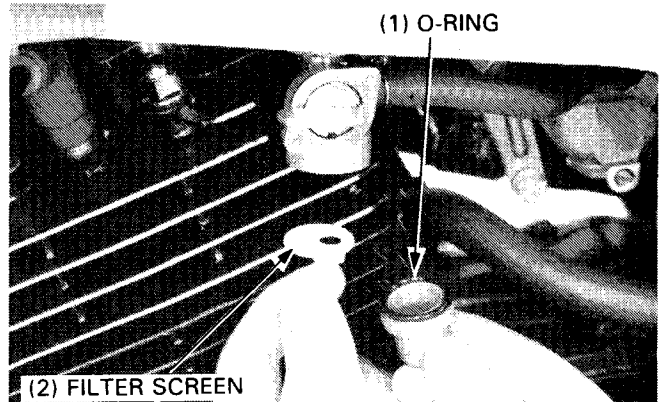
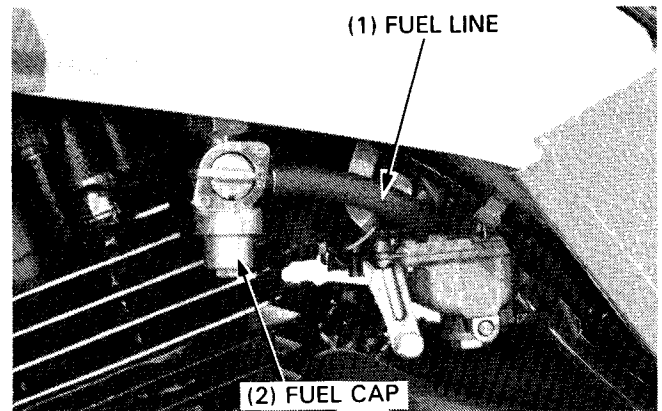

MAINTENANCE

Make sure the throttle lever free play is 3–8 mm (1/8–5/16 in) at the tip of the throttle lever.

THROTTLE LEVER FREE PLAY: 3–8 mm (1/8–5/16 in)

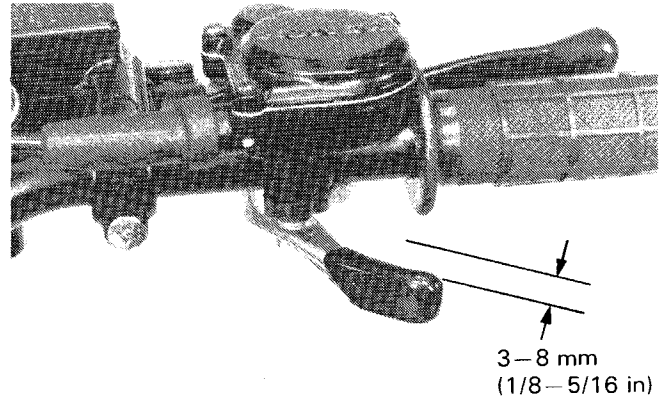

To adjust the free play slide back the rubber cap, loosen the lock nut and turn the adjuster. Tighten the lock nut and reinstall the rubber cap.

Check that the throttle lever moves smoothly and returns completely.

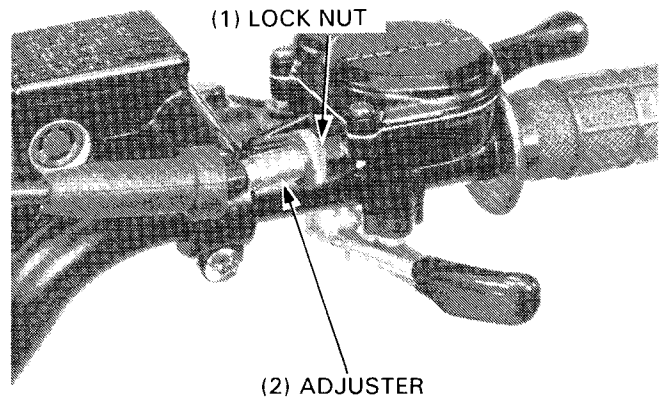

IGNITION TIMING

NOTE

- The Capacitive Discharge Ignition (CDI) system is factory pre-set and does not require adjustment. To inspect the function of the CDI components, ignition timing inspection procedures are given here.

Remove the timing hole cap.

Connect a tachometer and timing light.

Start the engine and allow it to idle.

IDLE SPEED: 1,400 ± 100 rpm

Inspect the ignition timing.

Timing is correct if the "F" mark on the generator rotor is aligned with the index mark on the left crankcase cover at idle.

Raise the engine speed and check timing advance.

At 1,800 ± 200 rpm: Timing advance should start.

At 3,500 ± 200 rpm: Timing advance should cease. The index mark should be between the full advance marks.

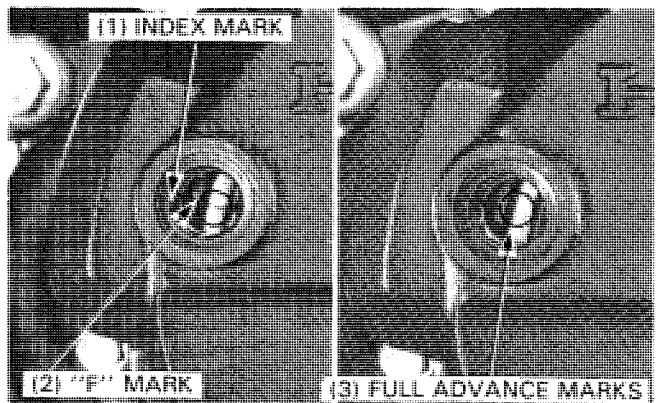
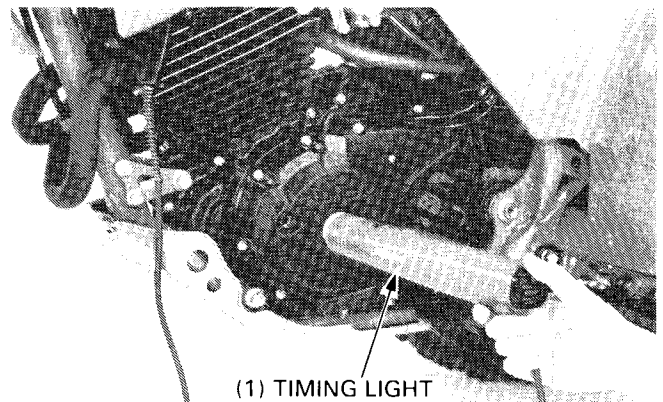

If the ignition timing is incorrect, refer to page 16-3.

CYLINDER COMPRESSION

Warm up the engine.
 Stop the engine and remove the spark plug.
 Disconnect the decompressor cable at the cam follower shaft arm.
 Insert a compression gauge.
 Push the choke lever down fully.
 Open the throttle lever fully and operate the kick starter pedal several times.

NOTE

- Be sure compression does not leak at the gauge connection.

COMPRESSION: 1,250 ± 100 kPa
 (12.5 ± 1.0 kg/cm², 178 ± 14.2 psi)

Low compression can be caused by:

- Improper valve adjustment.
- Valve leakage.
- Blown cylinder head gasket.
- Worn piston ring or cylinder.

High compression can be caused by:

- Carbon deposits in combustion chamber or on piston head.

Connect and adjust the decompressor cable (page 3-5).
 Install the spark plug.

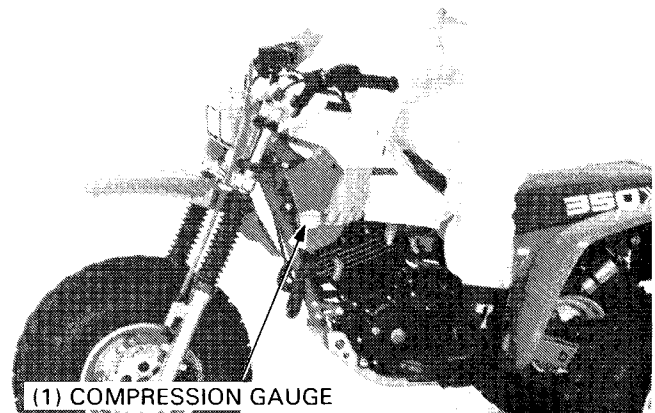

DRIVE CHAIN

CHAIN SLACK INSPECTION

WARNING

- *Never inspect or lubricate the drive chain while the engine is running.*

With the engine off, shift the transmission into neutral.
 Measure the drive chain slack midway between the sprockets.

CHAIN SLACK: 35–45 mm (1-3/8–1-3/4 in)

CHAIN SLACK ADJUSTMENT, '85:

Loosen the two lock bolts using the tool provided in the tool kit.

Turn the adjuster to decrease or increase chain slack using the adjusting tool provided in the tool kit.

INCREASE: Turn the adjuster clockwise

DECREASE: Turn the adjuster counterclockwise

Then tighten the lock bolts.

TORQUE: 13–18 N·m (1.3–1.8 kg-m, 9–13 ft-lb)

NOTE

- If drive chain slack is excessive when the adjuster is moved to the limit of adjustment, the drive chain is worn and must be replaced.

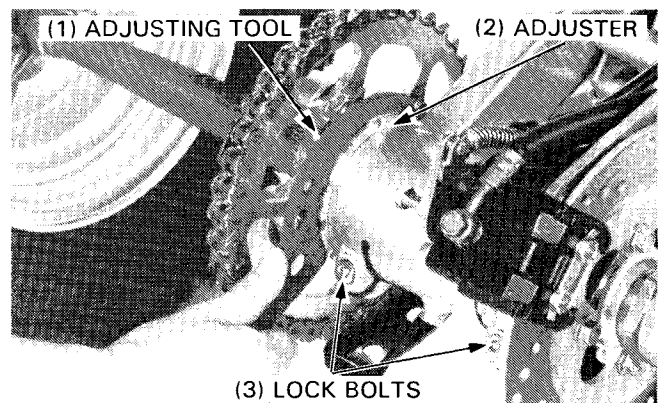
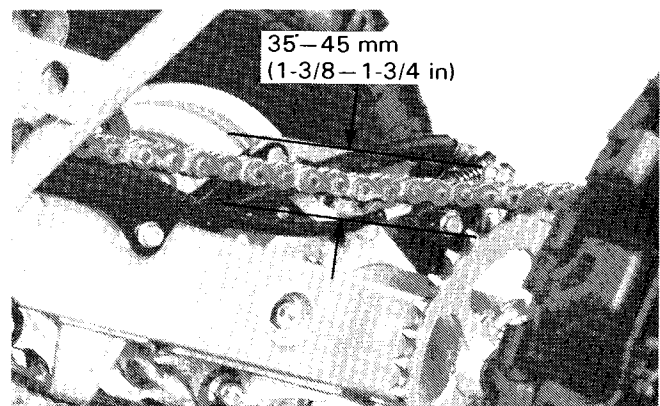

MAINTENANCE

CHAIN SLACK ADJUSTMENT, After '85:

Loosen the two lock bolts using the tool provided in the tool kit.

Turn the adjuster to decrease or increase chain slack using the hex wrench provided in the tool kit.

INCREASE: Turn the adjuster clockwise

DECREASE: Turn the adjuster counterclockwise

Then tighten the lock bolts.

TORQUE: 18–25 N·m (1.8–2.5 kg-m, 13–18 ft-lb)

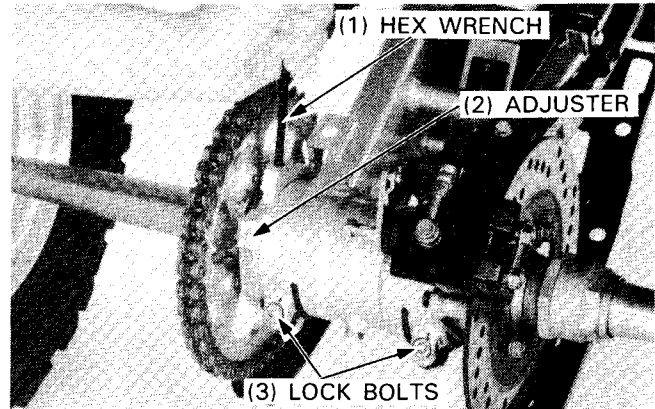

DRIVE CHAIN/SPROCKET INSPECTION/ LUBRICATION

Inspect the sprocket teeth for excessive wear or damage. Replace if necessary.

NOTE

- Never install a new drive chain on worn sprockets or a worn chain on new sprockets.
- Both chain and sprockets must be in good condition, or the new replacement chain or sprockets will wear rapidly.

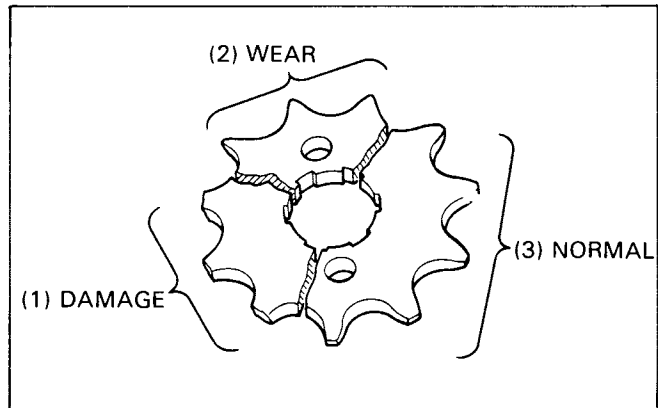

Remove the drive chain by removing the retaining clip and master link.

Clean the drive chain with a non-flammable or high flash point solvent that will not damage the O-rings, and wipe dry.

CAUTION

- Do not use a steam cleaner, high pressure washers or solvents as these will damage the O-rings.

Lubricate the drive chain with SAE #80 or #90 gear oil.

CAUTION

- Do not use commercial aerosol chain lubricants. They contain solvents which could damage the O-rings.

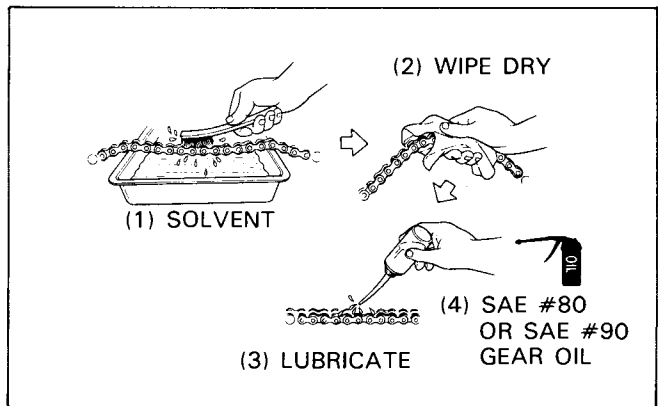

Measure the drive chain length with the chain held so that all links are straight.

89 PIN LENGTH:

STANDARD: 1,413 mm (55.6 in)

SERVICE LIMIT: 1,420 mm (55.9 in)

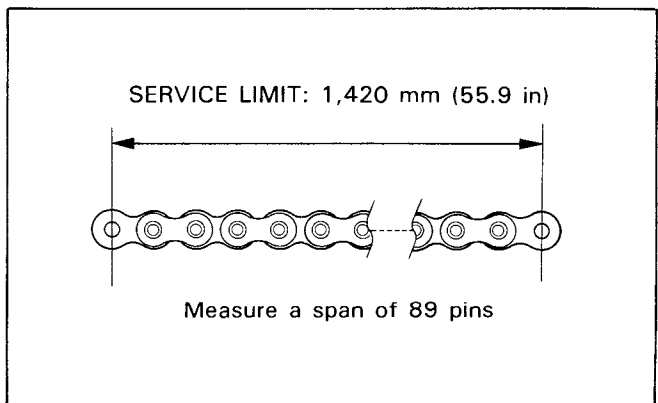

Install the drive chain.
Install the master link with O-rings and chain retaining clip.

NOTE

- The closed end of the clip should face the direction of drive chain travel.

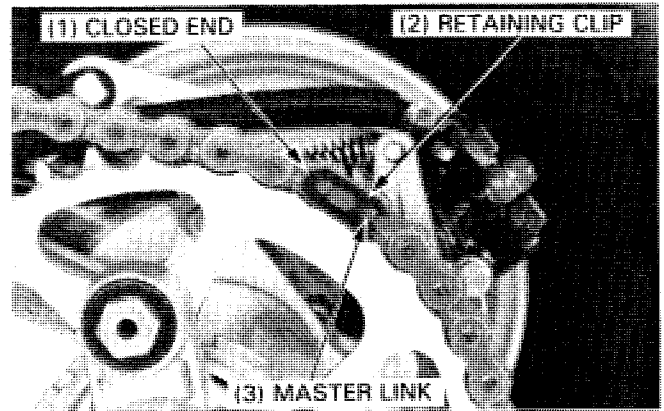

CAUTION

- Do not assemble the drive chain without the four O-rings.
- Be sure that there is no space between the master link and chain retaining clip.

Adjust the drive chain.

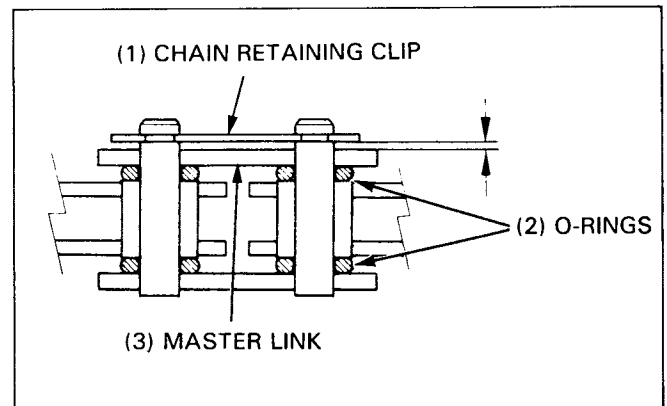

DRIVE CHAIN SLIDER

Check the drive chain slider for wear or damage.

When the depth of the grooves in the slider reaches 2.0 mm (0.08 in), remove material to lower the height of the center ridge between the grooves to less than 2.0 mm (0.08 in).

Replace the slider when the depth of the grooves reaches 6.0 mm (0.24 in).

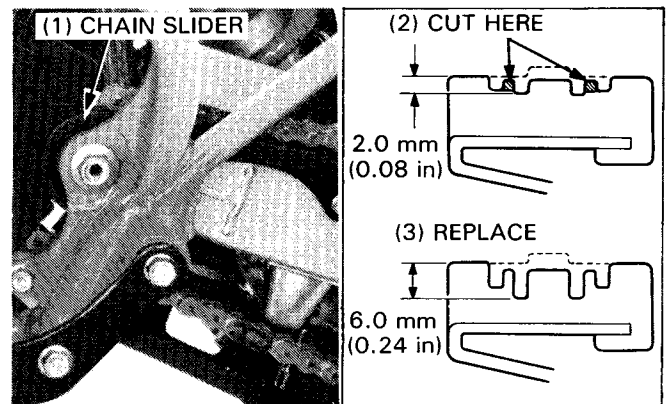

SUSPENSION

FRONT SUSPENSION

Check the action of the front forks by compressing them several times.

Check the entire fork assembly for signs of leaks or damage. Replace damaged components which cannot be repaired.

NOTE

- Do not repair bent fork tubes. They must be replaced.

Tighten all nuts and bolts to the specified torque values.



MAINTENANCE

Raise the front of the vehicle so that there is no weight on the front wheel.

Check air pressure in each fork tube.

STANDARD AIR PRESSURE: 0 kPa (0 kg/cm², 0 psi)

NOTE

- Use of more than 70 kPa (0.7 kg/cm², 10 psi) is not recommended because fork action becomes stiff.

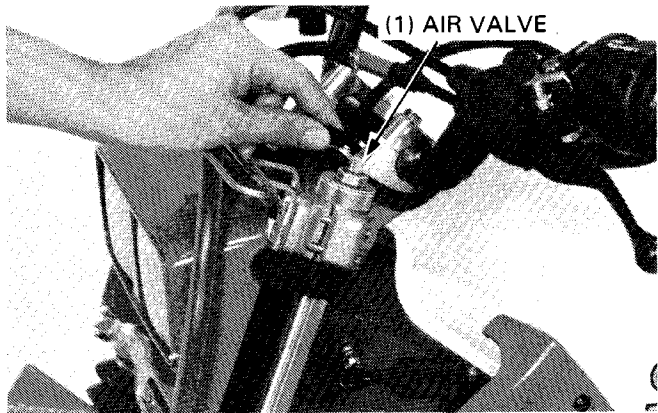

REAR SUSPENSION

Check the shock absorber for a leak or damage.

Check the suspension operation.

Adjust the spring preload if necessary (page 13-8).

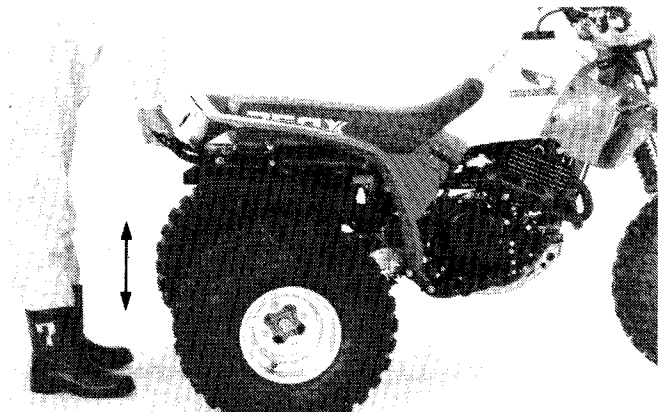

Raise the rear wheels off the ground with a jack or block under the engine.

Move the rear axle side ways with force to see if the wheel and swing arm bearings are worn.

Replace the bearings if there is any play (Section 13).

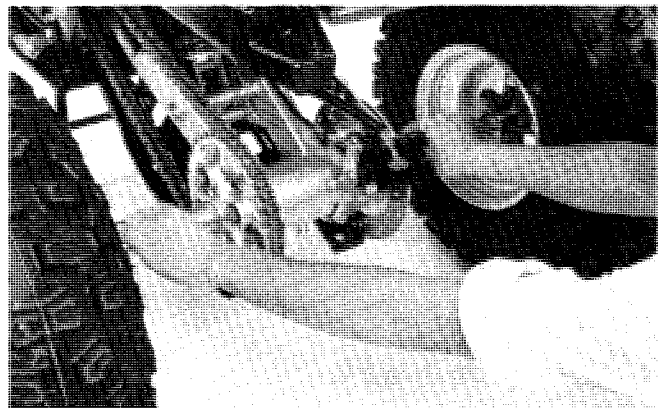

BRAKE PADS

Visually inspect the front brake pad for wear from the bottom of the caliper.

Visually inspect the rear brake pad for wear from the rear of the caliper.

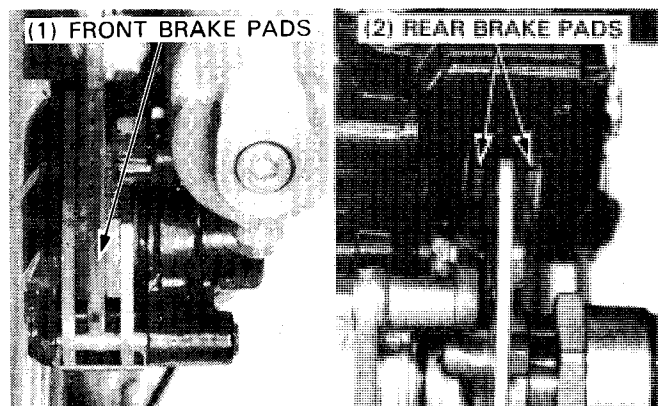

Replace the brake pads if the wear groove on the pads reaches the edge of the brake disc.

CAUTION

- *Always replace the brake pads as a set to assure even disc pressure.*

Refer to page 14-6 for brake pad replacement.

BRAKE FLUID

Check the front and rear brake fluid reservoir level.

If the level nears the lower level mark, remove the cap and fill the reservoir with DOT-3 or 4 brake fluid to the upper level mark.

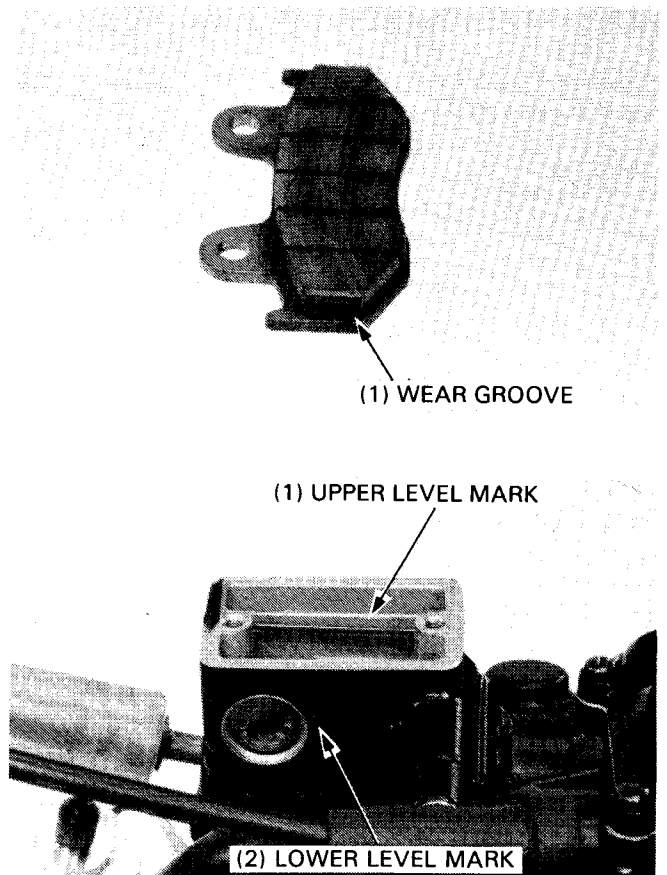

Check the entire system for leaks, if the level is low.

CAUTION

- *Do not remove the cover until the handlebar has been turned so that the reservoir is level.*
- *Do not mix DOT5 with DOT3 or 4 Brake Fluid.*
- *Avoid spilling fluid on painted, plastic or rubber parts. Place a rag over these parts whenever the system is serviced.*

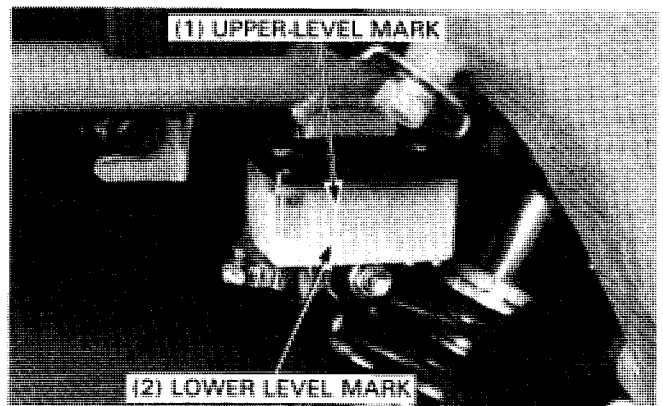

BRAKE SYSTEM

Inspect the brake hoses and fittings for deterioration, cracks and signs of leakage. Tighten any loose fittings.

Replace hoses and fittings as required.

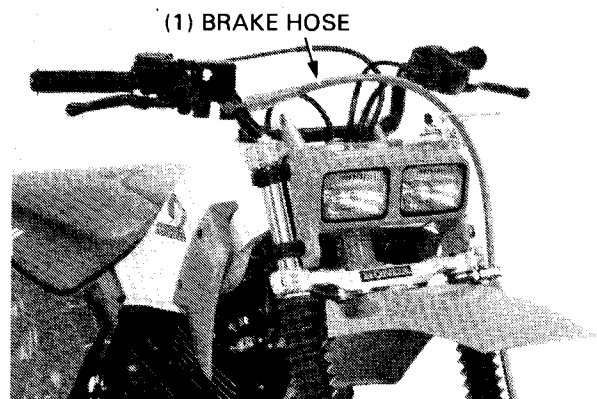

MAINTENANCE

REAR BRAKE PEDAL HEIGHT

Check that the distance between the pedal and upper face of the foot peg is 0 mm (0 in).

CAUTION

- *Incorrect brake pedal height can cause brake drag.*

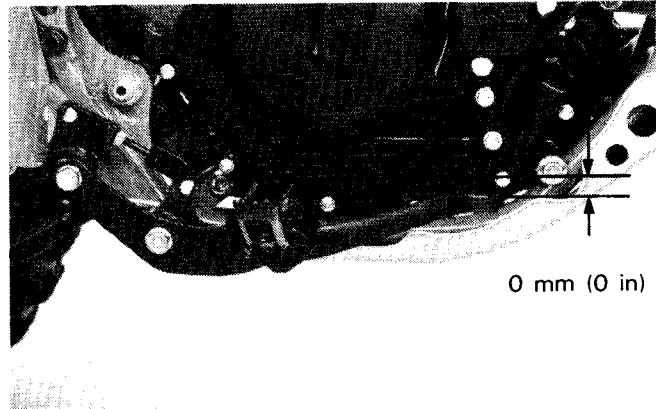

To adjust the height, loosen the lock nut and turn the master cylinder push rod. Tighten the lock nut.

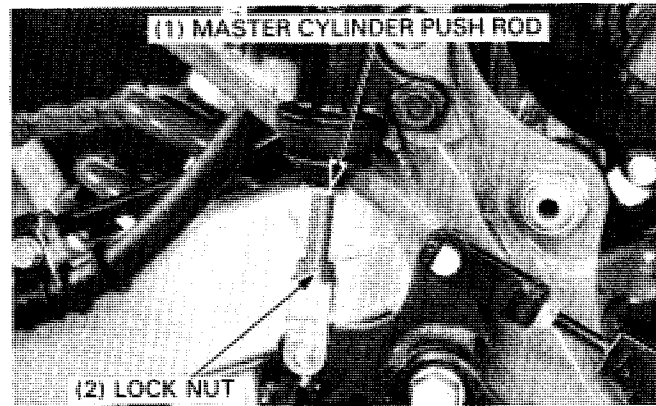

PARKING BRAKE

A parking brake adjustment may be required if the parking brake does not hold the rear wheels properly: Disconnect the clutch cable at the lower end. Press the parking brake button and pull in the clutch/parking brake lever.

Measure the free play at the tip of the lever.

FREE PLAY: 31–39 mm (1-3/16–1-1/2 in)

(1) PARKING BRAKE BUTTON

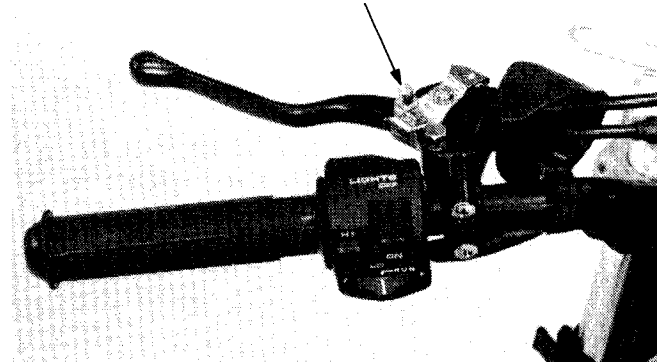

Adjust as follows:
Loosen the lock nut on the rear caliper.

Screw in the adjusting bolt until you feel resistance without applying the clutch/parking brake lever, and tighten the lock nut.

TORQUE: 15–20 N·m (1.5–2.0 kg-m, 11–15 ft-lb)

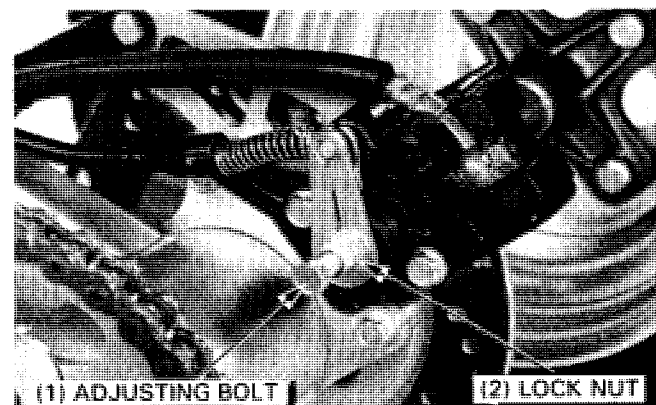

Recheck the lever free play and adjust, if necessary, by loosening the lock nut and turning the adjuster.
Tighten the lock nut.
Reconnect the clutch cable.

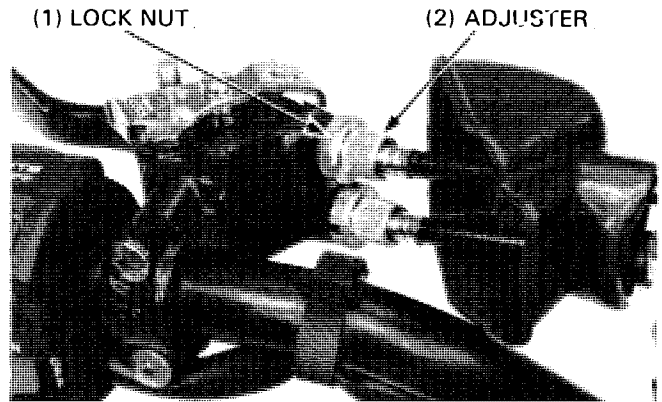

REAR BRAKE PIVOTS

Disconnect the actuating arm from the master cylinder push rod by removing the cotter pin and joint pin.

Remove the right foot peg bolts and foot peg.

Remove the actuating arm/pedal and return spring.

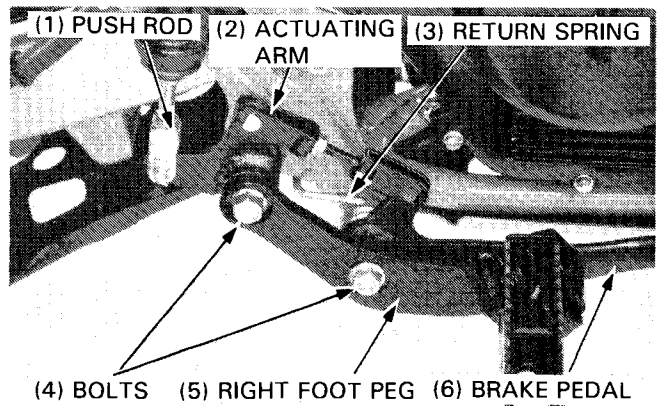

Check the I.D. of the actuating arm and brake pedal, and the O.D. of the pivot shafts for wear or damage.
Replace any parts that are excessively worn.

Install the return spring onto the frame.

Apply grease to the brake pedal and actuating arm pivots and install the brake pedal/actuating arm assembly onto the pivots.

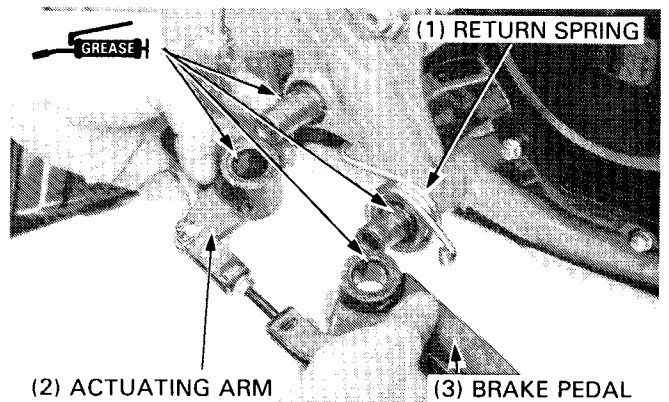

Install the right foot peg and tighten the bolts.

TORQUE: 40–50 N·m (4.0–5.0 kg·m, 29–36 ft·lb)

Connect the master cylinder push rod to the actuating arm using the joint pin and secure it with a new cotter pin.

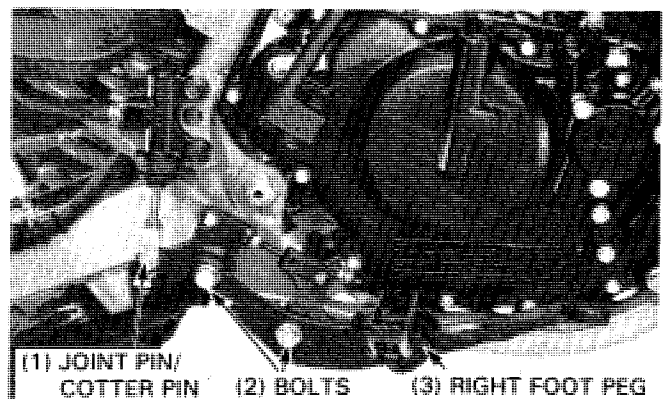

MAINTENANCE

CLUTCH

Measure the clutch lever free play:

FREE PLAY: 10–20 mm (3/8–3/4 in)

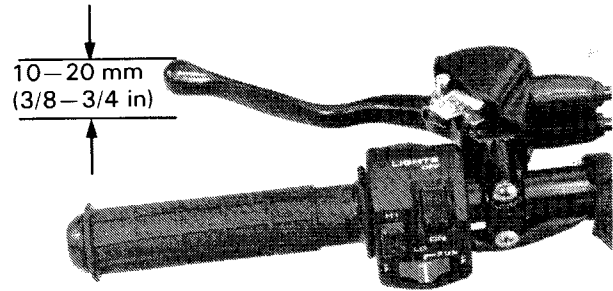

Perform minor adjustments with the upper adjuster.

Loosen the lock nut and turn the adjuster to obtain the specified free play.

Tighten the lock nut.

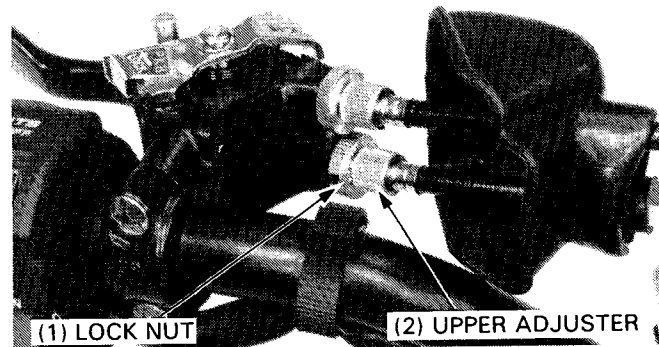

Perform major adjustments with the middle adjuster:

Loosen the lock nut and turn the adjuster nut.

Tighten the lock nut.

Check the clutch operation.

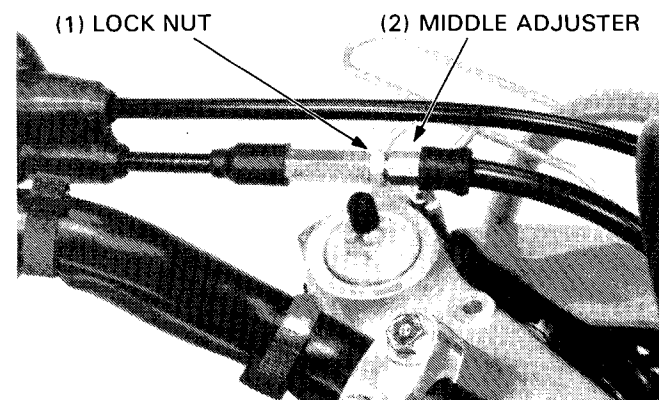

SPARK ARRESTER

WARNING

- *Do not remove or install the muffler lid while the exhaust pipe is hot.*
- *Perform this operation in a well-ventilated area, free from fire hazard.*
- *Use adequate eye protection.*

Remove the muffler lid. Block the end of the muffler with a shop towel.

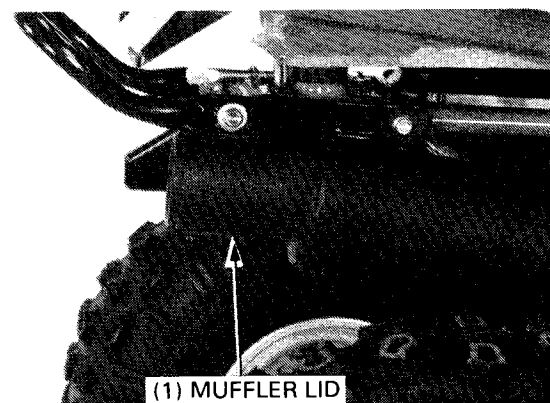

Start the engine and rev it up about 20 times to blow accumulated carbon deposits out the muffler.

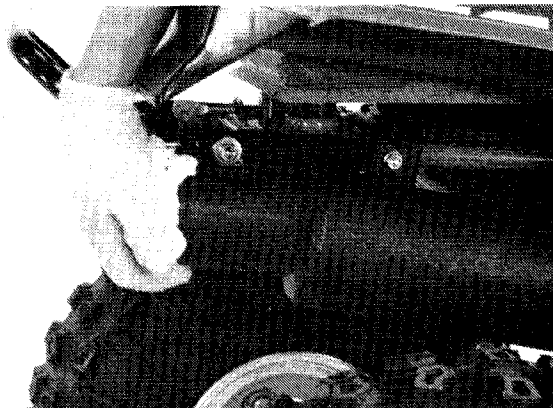

Be sure that the muffler lid bolts and gasket are in good condition. Replace the bolts and gasket if necessary.

Install the muffler lid and gasket and tighten the bolts securely.

CAUTION

- Do not remove the two screws from the end of the spark arrester.
- The two mounting screws must be installed in the spark arrester body at all times for the spark arrester to be effective.

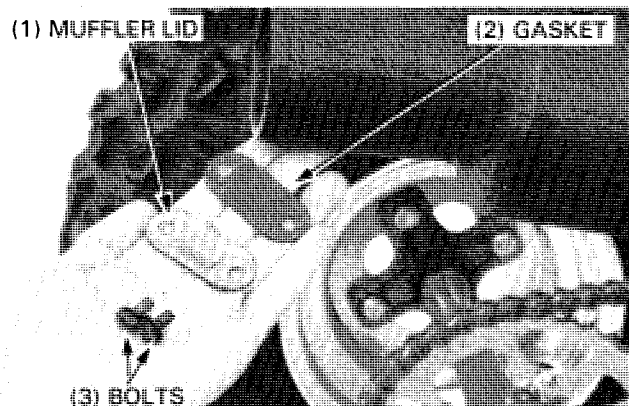

NUTS, BOLTS, FASTENERS

Tighten bolts, nuts and fasteners at regular intervals as shown in the Maintenance Schedule.

Check that all chassis nuts and bolts are tightened to their correct torque values (page 1-5). Check that all cotter pins and safety clips are in place.

WHEELS/TIRES

Check the tire for cuts, imbedded nails, or other damage.

NOTE

- Tire pressure should be checked when the tires are COLD.
- Raise the wheels off the ground when measuring tire circumferences.

Check the tire pressure and measure the tire circumference. Adjust accordingly.

	Recommended pressure	Standard tire circumference
Front	4.0 psi (28 kPa, 0.28 kg/cm ²)	1,901 mm (74.8 in)
Rear	3.0 psi (21 kPa, 0.21 kg/cm ²)	1,734 mm (68.3 in)

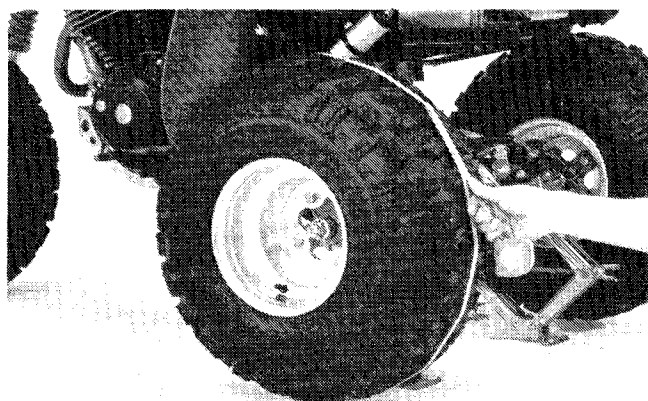

STEERING HEAD BEARINGS

NOTE

- Make sure the cables do not interfere with the rotation of the handlebar.

Raise the front wheel off the ground and make sure that the handlebar rotates freely.

If the handlebar moves unevenly, binds or has vertical play adjust the steering head bearings (page 11-24).

If after adjustment the handlebar still move unevenly binds or has vertical play, inspect the steering head bearings and replace if necessary (page 11-22).



MEMO

FUEL SYSTEM

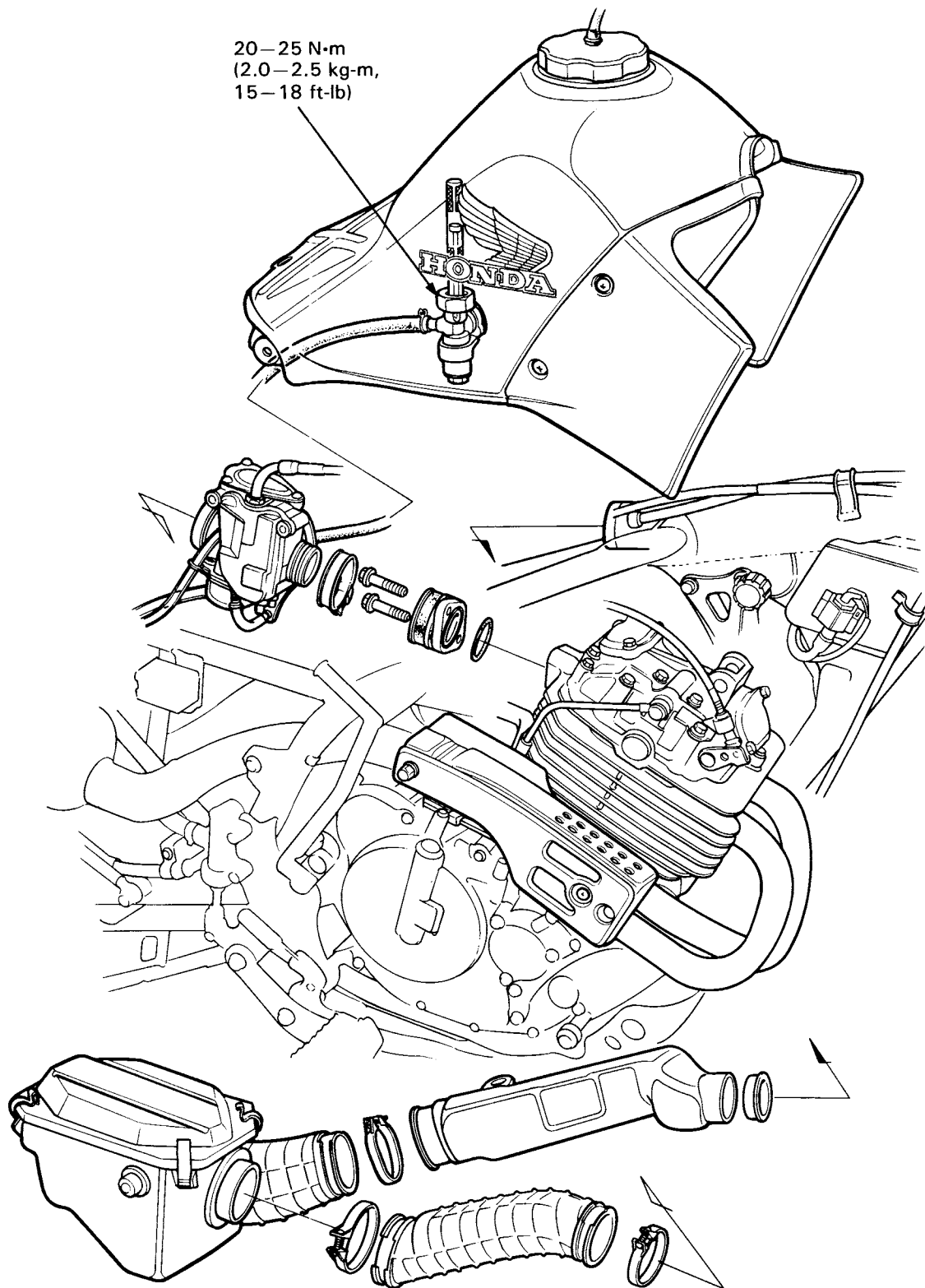

4. FUEL SYSTEM

SERVICE INFORMATION	4-1	CARBURETOR CHOKE	4-6
TROUBLESHOOTING	4-2	FLOAT CHAMBER	4-7
FUEL STRAINER CLEANING	4-3	THROTTLE VALVE	4-9
FUEL TANK	4-3	CARBURETOR INSTALLATION	4-11
AIR CLEANER CASE	4-4	PILOT SCREW ADJUSTMENT	4-11
CARBURETOR REMOVAL	4-5	HIGH ALTITUDE ADJUSTMENT	4-12

SERVICE INFORMATION

GENERAL

- Use caution when working with gasoline. Always work in a well ventilated area away from sparks or flames.
- When disassembling fuel system parts, note the locations of the O-rings. Replace them with new O-rings during re-assembly.
- The carburetor float bowl has a drain screw that can be loosened to drain gasoline.

CAUTION

- *Do not bend or twist control cables. Damage control cables will not operate smoothly and may stick or bind.*

SPECIFICATIONS

Fuel tank capacity 10.0 liter (2.65 US gal, 2.20 Imp. gal)
Fuel reserve capacity 2.0 liter (0.53 US gal, 0.44 Imp. gal)
Carburetor

Identification mark	'85: QA05A, After '85: QA10A
Type	Dual valve
Venturi diameter	31 mm (1.22 in)
Float level	18.5 mm (0.73 in)
Pilot screw opening	1-3/4 turns out
Idle speed	1,400 ± 100 rpm
Main jet	#138
Slow jet	#45
Throttle lever free play	3–8 mm (1/8–5/16 in)
Jet needle	3rd groove

TORQUE VALUES

Fuel valve lock nut 20–25 N·m (2.0–2.5 Kg-m, 15–18 ft-lb)

TOOL

Common
Float level gauge 07401–0010000

TROUBLESHOOTING

Engine cranks but won't start

- No fuel in tank.
- No fuel to carburetor.
- Too much fuel getting to cylinder.
- No spark at plug (ignition malfunction).
- Air cleaner clogged.

Engine idles roughly, stalls, or runs poorly

- Idle speed incorrect.
- Ignition malfunction.
- Rich mixture.
- Lean mixture.
- Air cleaner dirty.
- Insulator leaks.

Lean mixture

- Carburetor fuel jet clogged.
- Fuel cap vent blocked.
- Fuel filter clogged.
- Fuel line kinked or restricted.
- Float valve faulty.
- Float level too low.

Rich mixture

- Carburetor choke stuck open.
- Float valve faulty.
- Float level too high.
- Carburetor air jet clogged.
- Air cleaner dirty.

FUEL STRAINER CLEANING

Disconnect the fuel tube.
 Drain fuel from the fuel tank into a suitable container.

WARNING

- *Keep gasoline away from flames or sparks.*
- *Wipe up spilled gasoline at once.*

Remove the fuel valve by loosening the valve nut.
 Remove and clean the strainer.

Install the strainer and valve, and attach the fuel line.
 Fill the fuel tank, turn the fuel valve to "ON" and check for leaks.

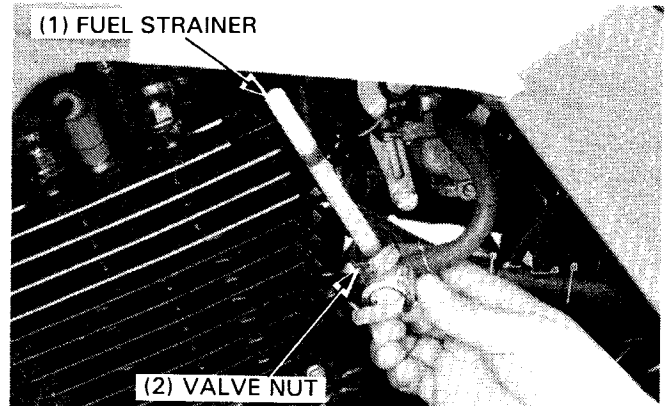

FUEL TANK

Remove the seat/rear fender.
 Turn the fuel valve OFF and disconnect the fuel line at the fuel valve.
 Remove the fuel tank mounting bolts and the tank.

WARNING

- *Keep gasoline away from flames or sparks.*
- *Wipe up spilled gasoline at once.*

Use a drain pan and check that fuel flows freely out of the fuel valve by turning the fuel valve ON.

If flow is restricted, clean the fuel strainer screen (page 3-7) and fuel strainer.
 Check the vent hole in the filler cap for blockage.

Install the fuel tank by sliding its front brackets onto the rubber cushions on the frame and tighten the mounting bolts.

Connect the fuel line to the fuel valve.
 Install the seat/rear fender.

Turn the fuel valve ON and make sure that there are no fuel leaks.

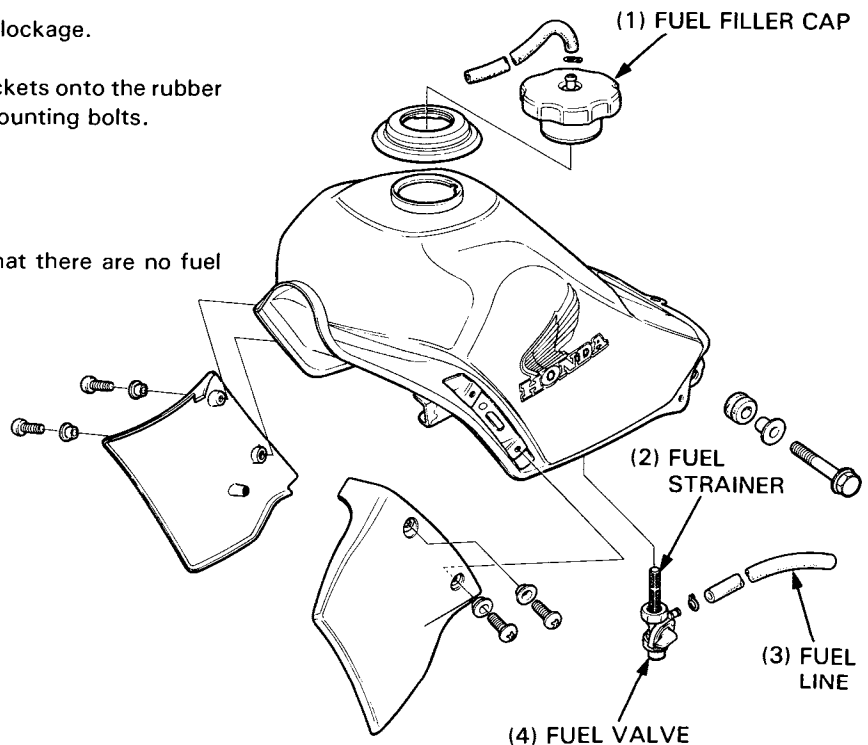
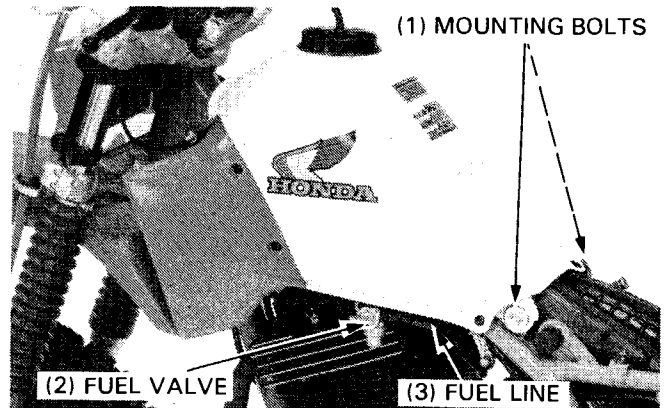

FUEL SYSTEM

AIR CLEANER CASE

REMOVAL/INSTALLATION

Remove the seat/rear fender.
Remove the CDI unit from its bracket.

Loosen the air cleaner connecting tube bands.
Remove the air cleaner case mounting bolt and the case.

Install the air cleaner case in the reverse order of removal

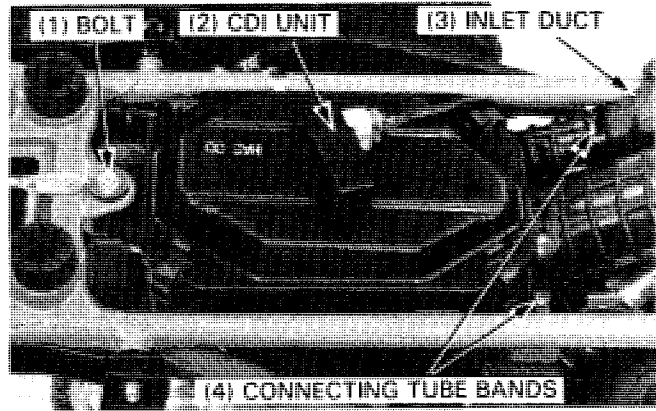

INLET DUCT REMOVAL

Remove the fuel tank (page 4-3).

Loosen the air cleaner inlet connecting tube band.
Remove the inlet duct mount bolt and the inlet duct.

Install the inlet duct in the reverse order of removal.

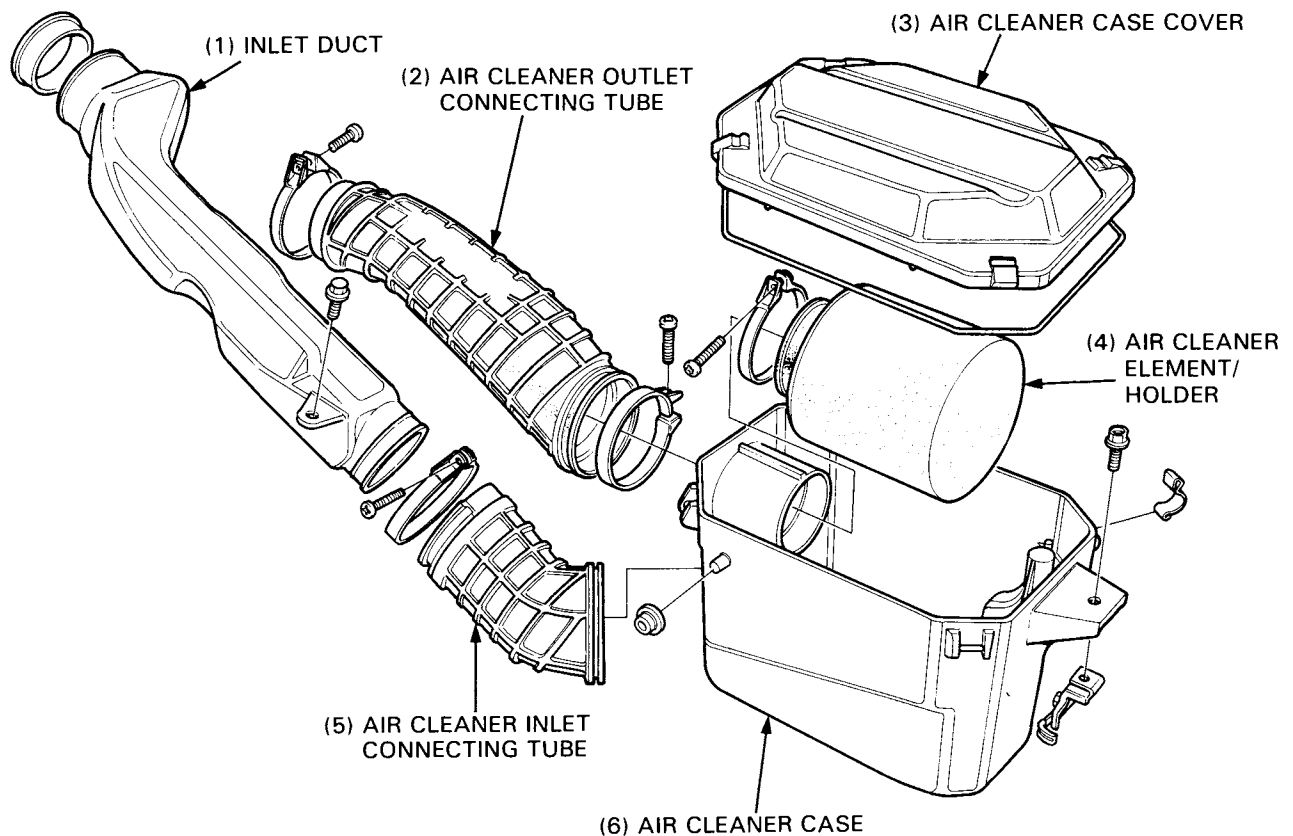

CARBURETOR REMOVAL

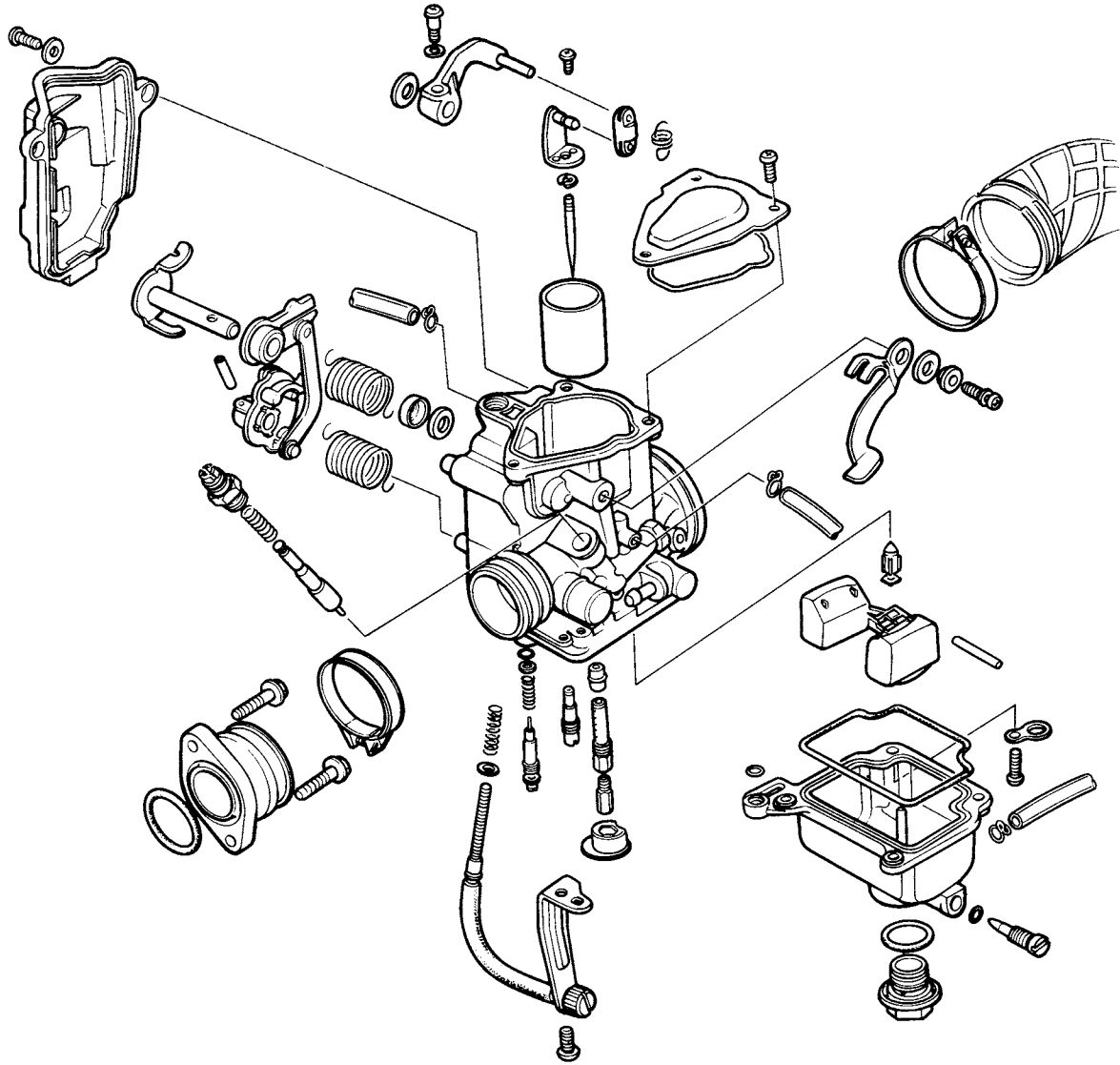

Remove the fuel tank (page 4-3).

Loosen the air cleaner connecting tube and carburetor insulator bands and remove the carburetor.

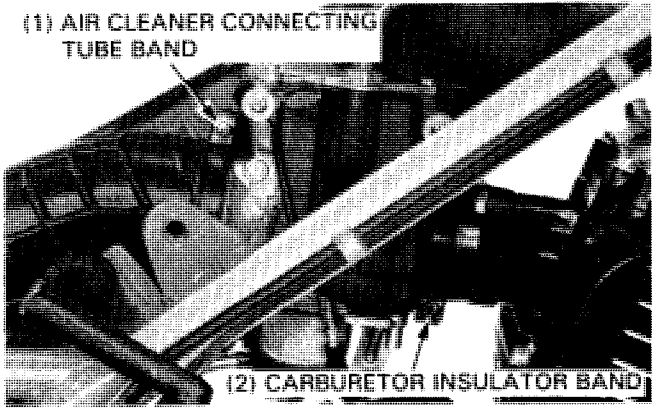

FUEL SYSTEM

Remove the two carburetor cover screws and the cover.

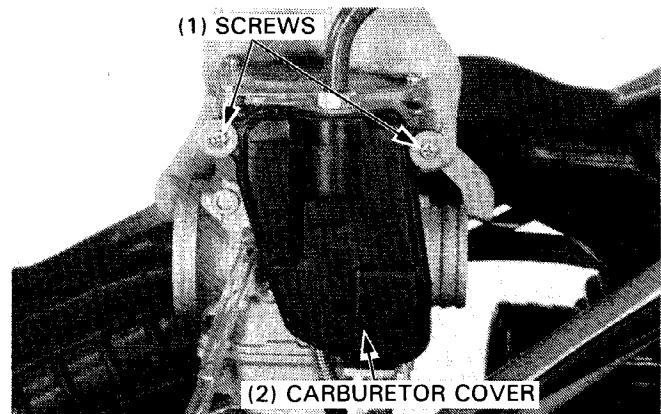

Disconnect the throttle cable end from the throttle drum.

Remove the throttle cable from the carburetor body.

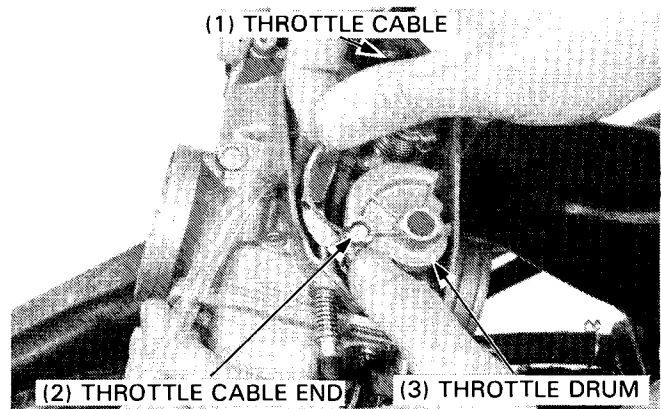

CARBURETOR CHOKE

The choke system uses a fuel enrichment circuit controlled by a starter valve. The starter valve opens the enrichment circuit when the choke lever is raised.

Check for smooth choke lever operation.

Remove the choke lever pivot screw and choke lever.

Loosen the starter valve nut and remove the valve from the carburetor.

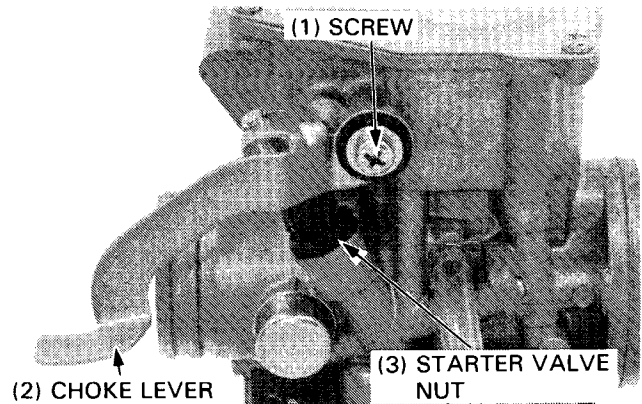

Check the starter valve and spring for nicks, grooves, or other damage.

Install the choke valve in the reverse order of removal.

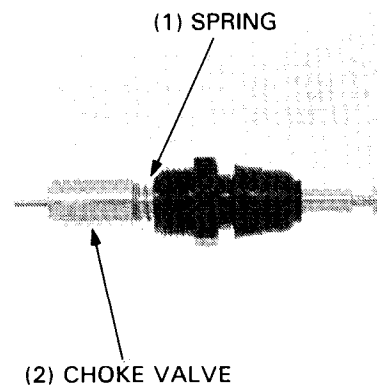

FLOAT CHAMBER

REMOVAL

Remove the four float chamber screws and the float chamber.

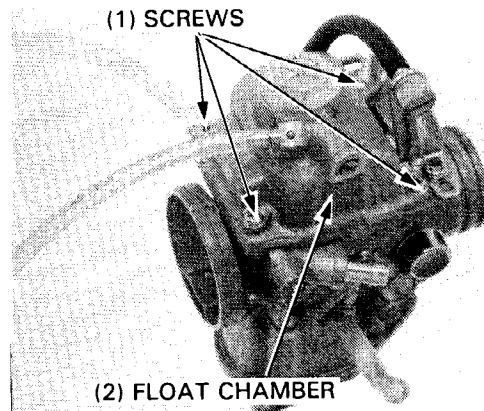

FLOAT LEVEL

Measure the float level with a float level gauge as shown.

SPECIFICATIONS: 18.5 mm (0.73 in)

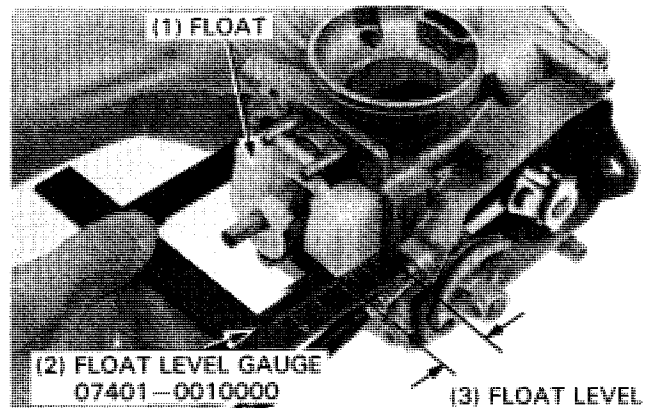

FLOAT AND JETS

Remove the float pin, baffle, float and float valve.

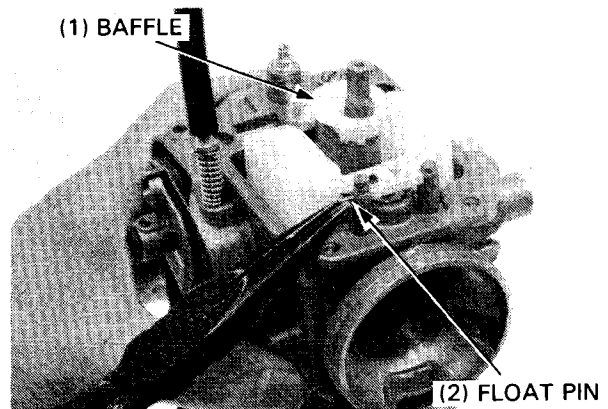

Inspect the float valve for grooves and nicks.
Replace as required.
Inspect the operation of the float valve.

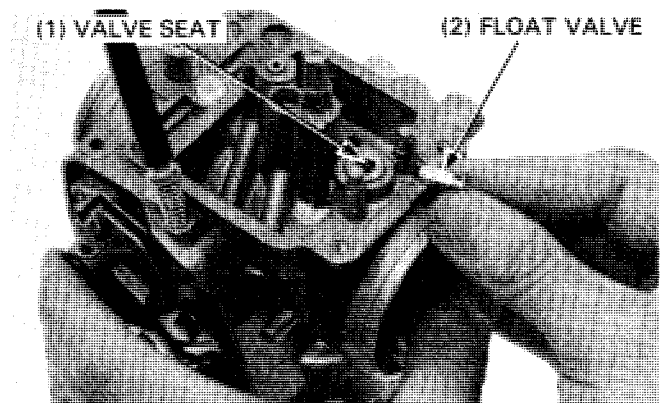

FUEL SYSTEM

Remove the main jet, needle jet holder and needle jet. Remove the slow jet.

Turn the pilot screw in and record the number of turns before it seats lightly. Use this as a reference for reinstallation.

CAUTION

- *Damage to the pilot screw seat will occur if the pilot screw is tightened against the seat.*

Remove the pilot screw.

Inspect the pilot screw and each jet and replace them if they are worn or damaged.

Blow open all jets with compressed air.

Remove the primary throttle valve (page 4-9) and blow open all carburetor body openings with compressed air.

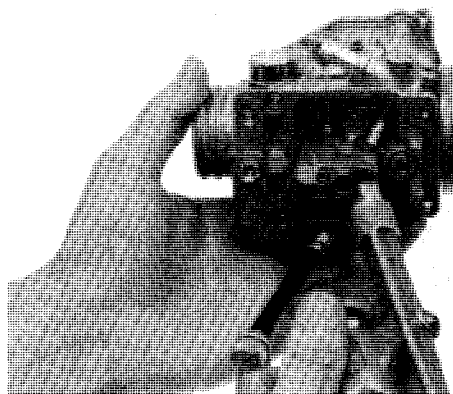
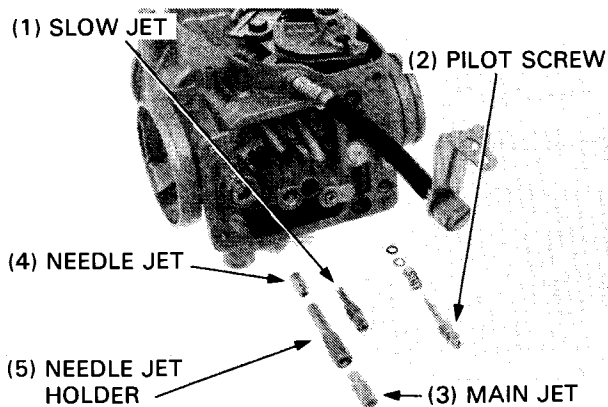
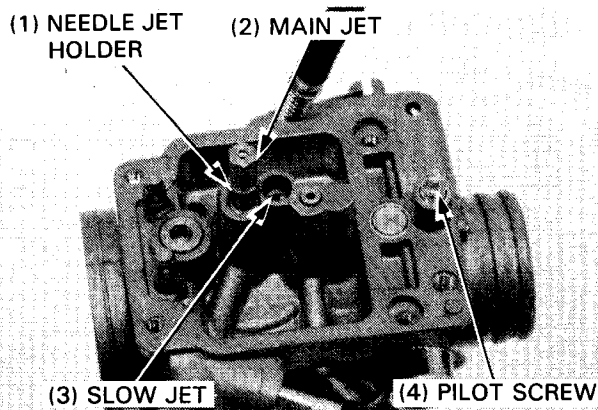

ASSEMBLY

Float chamber assembly is essentially the reverse order of disassembly.

NOTE

- Use new O-rings whenever the carburetor is reassembled.
- Handle all jets with care. They can easily be scored or scratched.
- Set the pilot screw to the position recorded during disassembly.
- Align the overflow tube on the chamber with the hole in the baffle as shown.

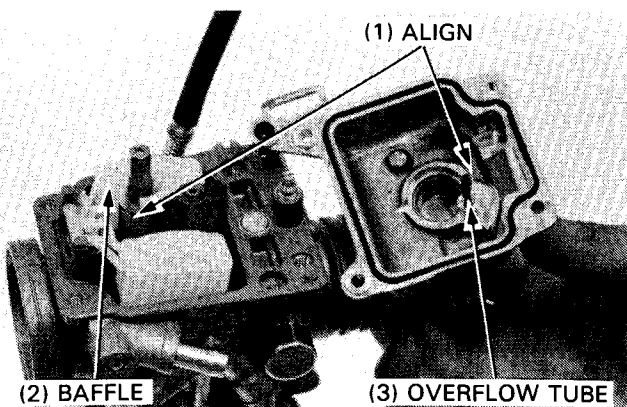

THROTTLE VALVE

NOTE

- The butterfly throttle valve attaching screws are staked and the valve can not be removed.

PISTON THROTTLE VALVE REMOVAL

Remove the three screws and the piston throttle valve cover.

(1) PISTON THROTTLE VALVE COVER

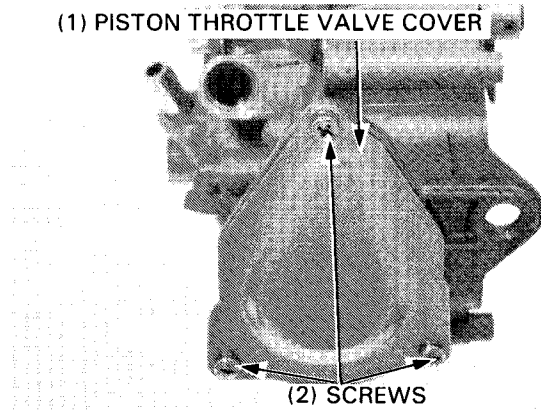

Remove the throttle valve arm set screw.

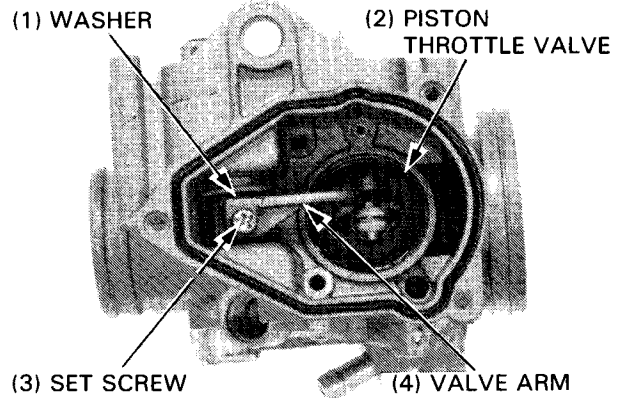

Pull the shaft out and remove the throttle valve and washer.

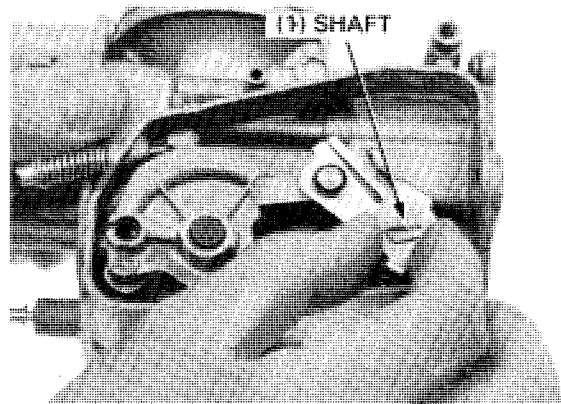

Remove the two screws attaching the valve arm to the valve, then remove the valve and jet needle from the arm.

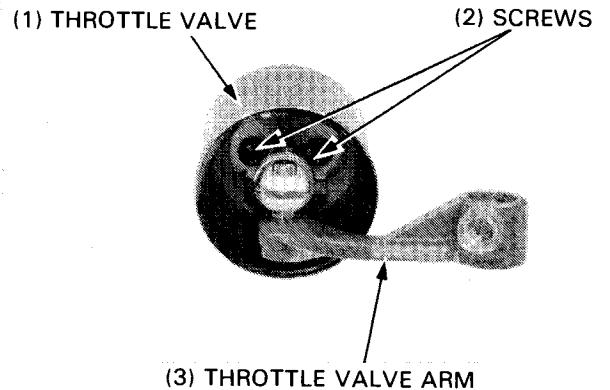

FUEL SYSTEM

Check the throttle valve and jet needle for wear or damage.

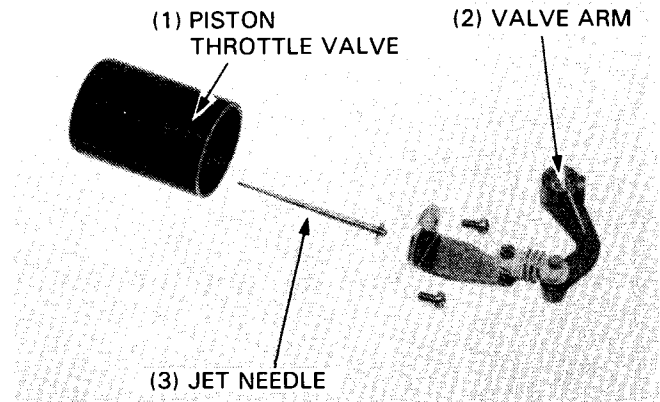

PISTON THROTTLE VALVE INSTALLATION

Install the needle clip on the jet needle.

STANDARD SETTING: 3rd groove

Install the piston throttle valve in the reverse order of removal.

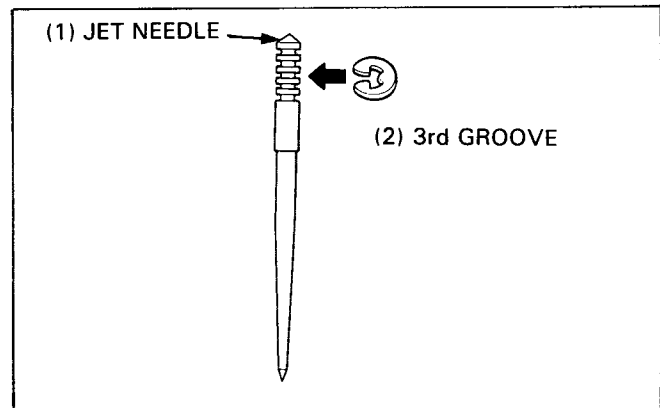

THROTTLE VALVE SYNCHRONIZATION

Close the butterfly throttle valve fully.

Make sure that the piston throttle valve is closed fully and there is no clearance between the throttle link and the piston throttle valve shaft arm.

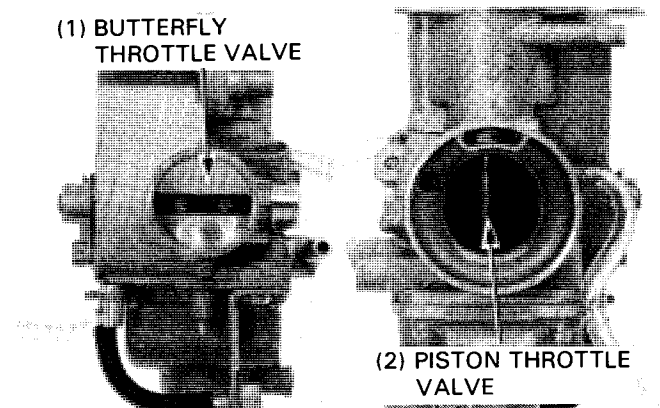

Adjust synchronization by opening or closing the slot in the throttle link.

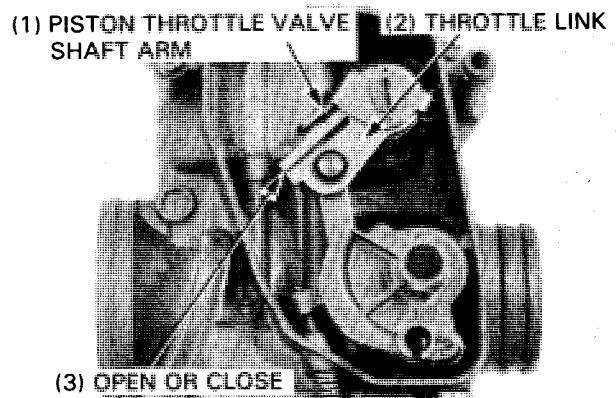

CARBURETOR INSTALLATION

Installation is essentially the reverse of removal.

NOTE

- Align the tab on the carburetor body with the groove in the carburetor insulator.
- Route the throttle cable properly (page 1-9).

Perform the following inspections and adjustments.

- Throttle operation (page 3-7).
- Carburetor idle speed (page 3-6).

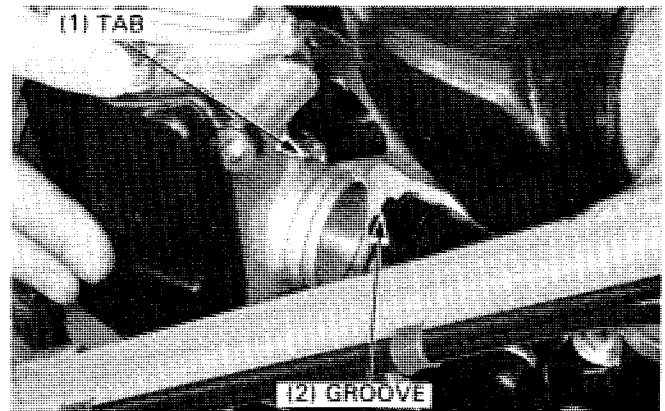

PILOT SCREW ADJUSTMENT

NOTE

- The pilot screw is factory pre-set. Adjustment is not necessary unless the carburetor is overhauled or a new pilot screw is installed.

CAUTION

- *Damage to the pilot screw seat will occur if the pilot screw is tightened against the seat.*

Turn the pilot screw clockwise until it seats lightly and back it out 1-3/4 turns. This is an initial setting prior to the final pilot screw adjustment.

Warm the engine up to operating temperature. Stop the engine and connect a tachometer.

Start the engine and adjust the idle speed with the throttle stop screw.

IDLE SPEED: 1,400 ± 100 rpm

Turn the pilot screw clockwise slowly until the engine stops, and then back it out 1 turn. Start the engine and readjust the idle speed with the throttle stop screw, if necessary.

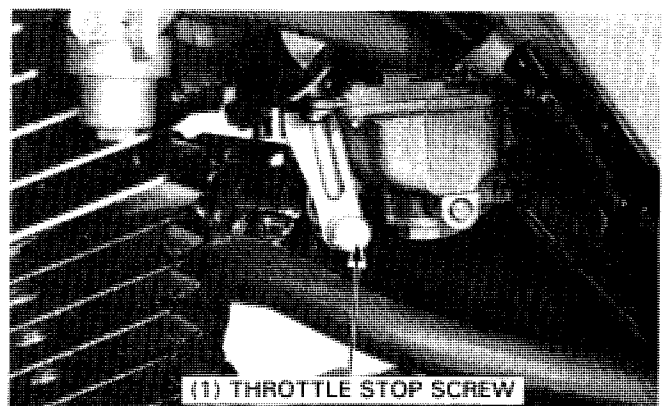
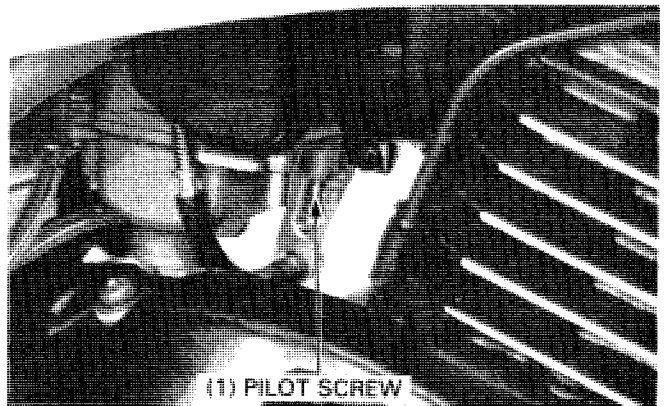

FUEL SYSTEM

HIGH ALTITUDE ADJUSTMENT

NOTE

- The standard jetting can be used up to 6,000 ft (1,800 m) and the high altitude jetting can be used down to 5,000 ft (1,500 m). It is not recommended to exceed these limits. See CAUTION below.

The carburetor must be adjusted for high altitude riding (above 6,000 ft/1,800 m).

STANDARD SETTING: 6,000 ft (1,800 m) max.

HIGH ALTITUDE SETTING: 5,000 ft (1,500 m) min.

The high altitude carburetor adjustment is performed as follows:

Remove the carburetor (page 4-5) and drain plug.

Replace the standard main jet with the high altitude type (#130).

Assemble and install the carburetor.

Start the engine and adjust the idle speed at high altitude to ensure proper high altitude operation.

CAUTION

- Sustained operation below 5,000 feet (1,500 m) with the high altitude settings may cause engine overheating and engine damage. Install the standard main jet and screw out the pilot screw 1/2 turn, when riding below 5,000 feet (1,500 m).*

SPECIFICATIONS

	Below 6,000 ft (1,800 m)	Above 5,000 ft (1,500 m)
Main jet	#138	#130
Pilot screw opening	Factory preset	'85: 1/2 turn in After '85: 1/4 turn in

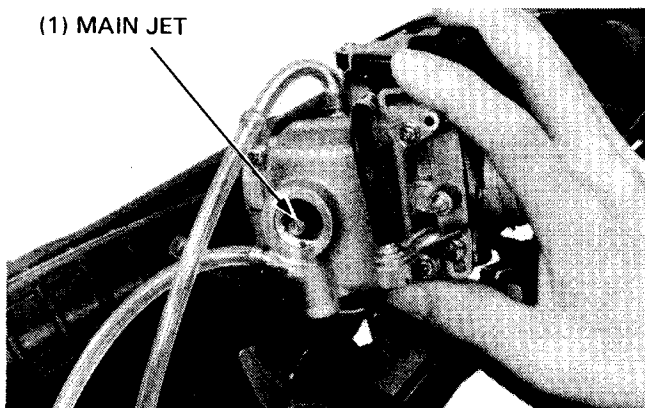

MEMO

ENGINE REMOVAL/INSTALLATION

'85 MODEL SHOWN. SEE PAGE 5-2 FOR AFTER '85

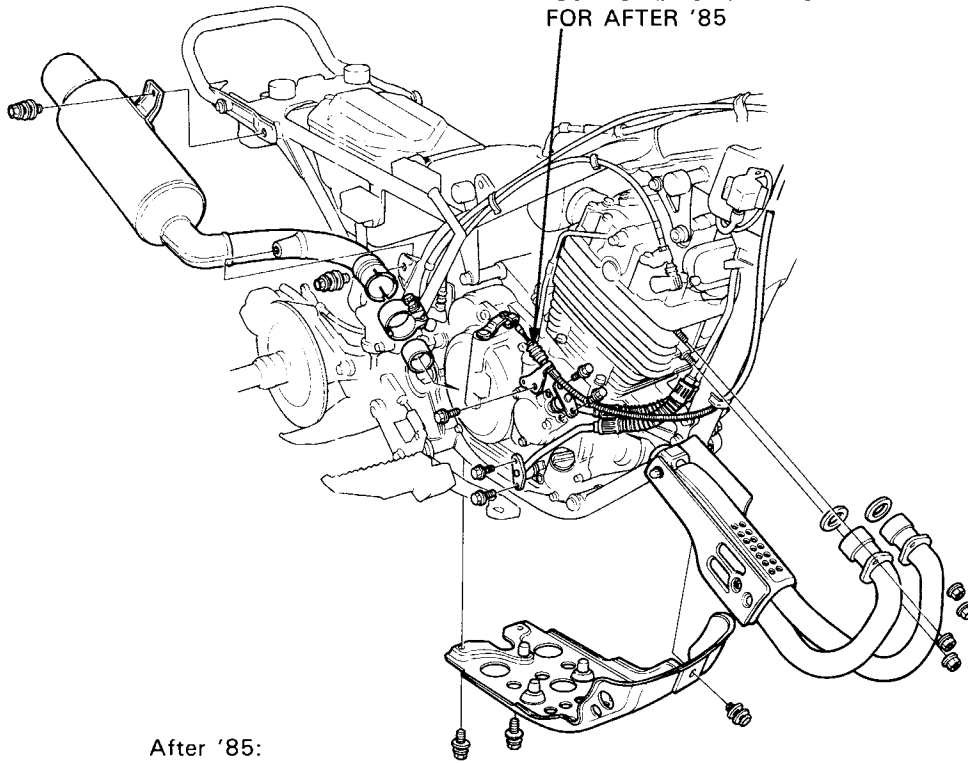

After '85:
55–65 N·m
(5.5–6.5 kg·m,
40–48 ft·lb)

'85:
24–35 N·m
(2.4–3.5 kg·m,
17–25 ft·lb)

'85:
55–65 N·m
(5.5–6.5 kg·m,
40–48 ft·lb)

55–65 N·m
(5.5–6.5 kg·m,
40–48 ft·lb)

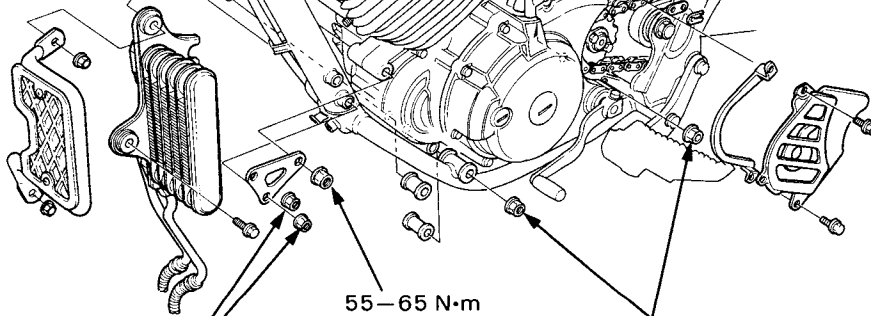

55–65 N·m
(5.5–6.5 kg·m,
40–48 ft·lb)

55–65 N·m
(5.5–6.5 kg·m,
40–48 ft·lb)

'85: 24–35 N·m (2.4–3.5 kg·m, 17–25 ft·lb)
After '85: 55–65 N·m (5.5–6.5 kg·m, 40–48 ft·lb)

5. ENGINE REMOVAL/INSTALLATION

SERVICE INFORMATION	5-1	ENGINE INSTALLATION	5-3
ENGINE REMOVAL	5-2		

SERVICE INFORMATION

GENERAL

- A floor jack or other adjustable support is required to support and maneuver the engine.
- The following parts or components can be serviced with the engine installed in the frame:
 - Carburetor
 - Oil pump
 - Alternator
 - Rocker arms and camshaft
 - Clutch
 - Kick starter
 - Gearshift linkage

SPECIFICATIONS

Engine dry weight	41.5 kg (91.5 lbs)
Engine oil capacity	2.3 lit. (2.43 US qt, 2.03 Imp qt) after disassembly 1.8 lit. (1.91 US qt, 1.59 Imp qt) after draining

TORQUE VALUES

Engine mounting bolts	
8 mm bolt	24–35 N·m (2.4–3.5 kg-m, 17–25 ft-lb)
10 mm bolt	55–65 N·m (5.5–6.5 kg-m, 40–48 ft-lb)

ENGINE REMOVAL

Remove the following:

- seat/rear fender (page 15-1)
- fuel tank (page 4-3)
- exhaust pipe and muffler (page 15-2)
- carburetor (page 4-5)
- oil cooler (page 2-3).

Disconnect the clutch cable from the clutch arm.

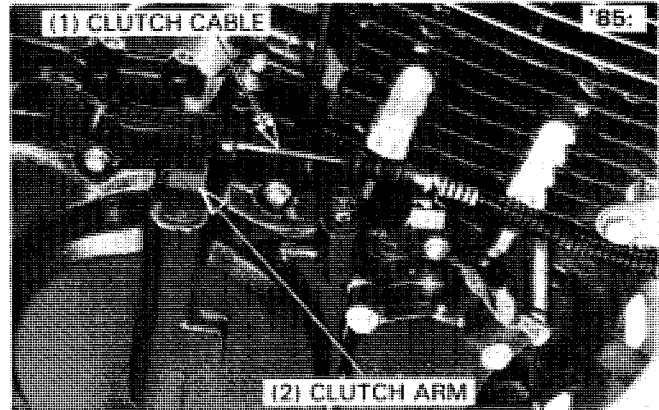

After '85:

Remove the clutch cable guide from the alternator cover. Disconnect the clutch cable from the clutch arm and cable holder.

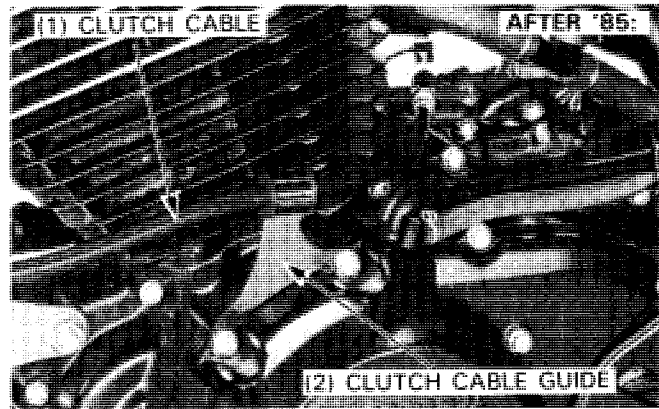

Remove the engine guard by removing the three bolts.

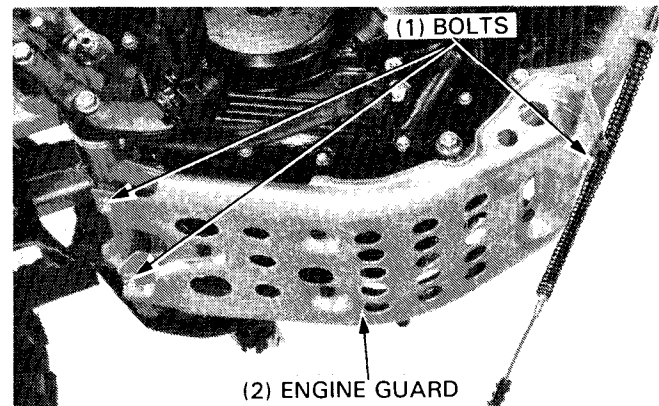

Remove the spark plug cap from the spark plug.

Disconnect the crankcase breather tube from the crankcase.

Disconnect the alternator and pulse generator wire couplers and connector.

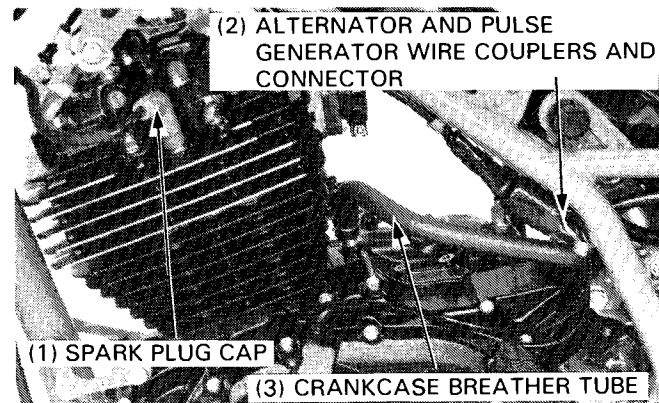

Loosen the drive chain (pages 3-9 and 3-10).

Remove the drive sprocket cover, chain guide and chain (page 9-2).

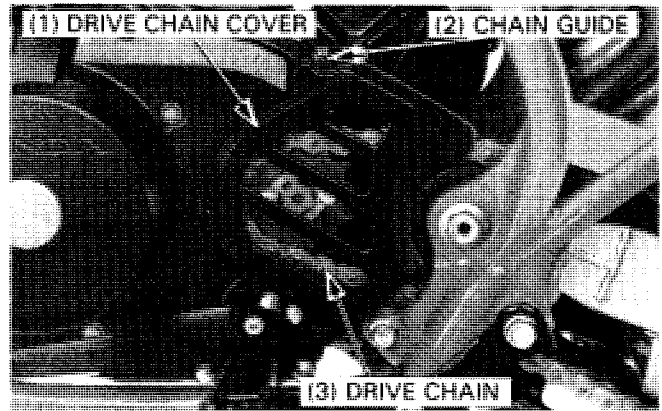

Place a floor jack or other adjustable support under the engine.

Remove the rear upper engine hanger plate bolts, plate and collar:

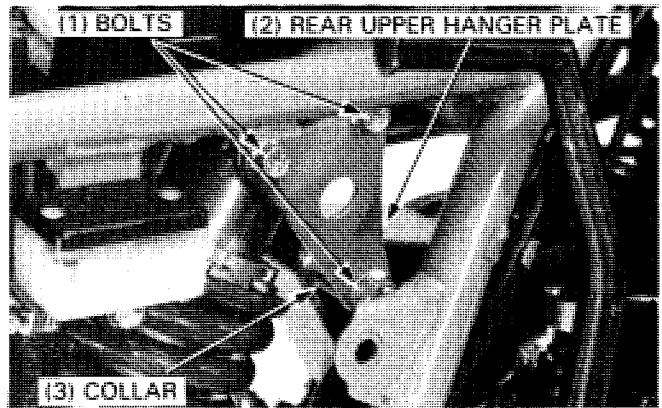

Remove the front upper and lower engine hanger plate bolts and the plates.

Remove the front and rear engine mounting bolts.

Remove the engine from the right side.

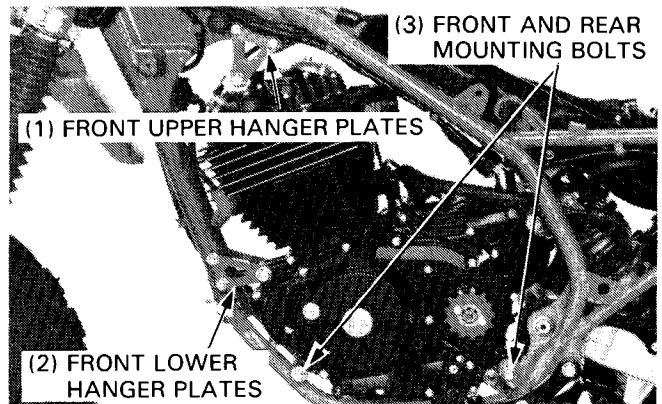

ENGINE INSTALLATION

Engine installation is essentially the reverse of removal. Tighten the all fasteners to the specified torque.

TORQUE:

ENGINE MOUNTING BOLTS

10 mm BOLTS	55–65 N·m (5.5–6.5 kg-m, 40–48 ft-lb)
8 mm BOLTS	24–35 N·m (2.4–3.5 kg-m, 17–25 ft-lb)

NOTE

- The engine hanger plates are marked "L" for left side or "R" for right side.
- Route the wires and cables properly (page 1-9).
- Fill the crankcase to the proper level with the recommended oil (page 2-1).
- Perform the following inspections and adjustments:
Throttle operation (page 3-7).
Clutch (page 3-16).

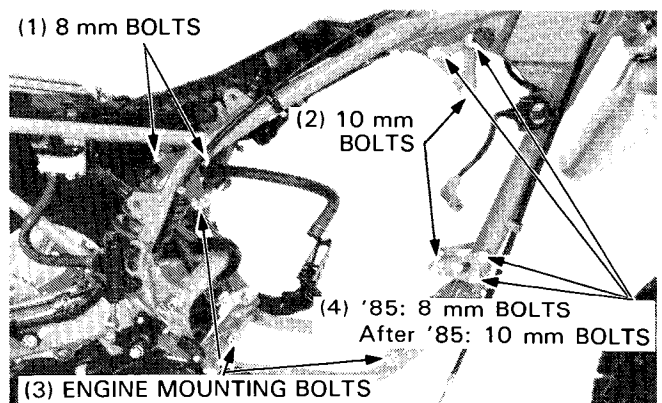

CYLINDER HEAD/VALVES

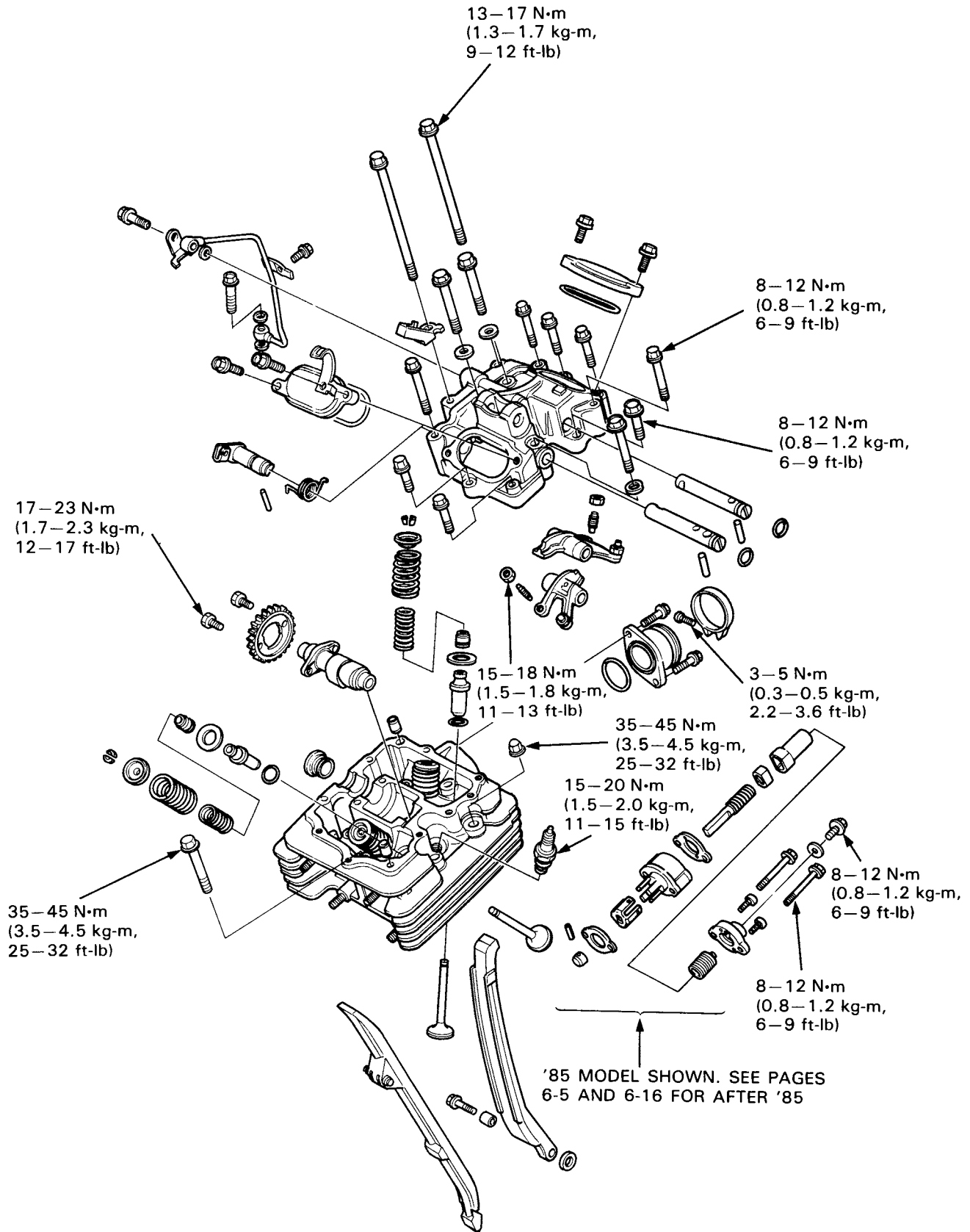

6. CYLINDER HEAD/VALVES

SERVICE INFORMATION	6-1	VALVE SEAT INSPECTION/REFACING	6-9
TROUBLESHOOTING	6-2	CAM CHAIN TENSIONER	6-11
CYLINDER HEAD COVER REMOVAL/ DISASSEMBLY	6-3	CYLINDER HEAD ASSEMBLY	6-12
CAM CHAIN TENSIONER LIFTER DISASSEMBLY	6-4	CYLINDER HEAD INSTALLATION	6-13
CAMSHAFT REMOVAL	6-5	CAMSHAFT INSTALLATION	6-14
CYLINDER HEAD REMOVAL	6-6	CAM CHAIN TENSIONER LIFTER ASSEMBLY	6-15
CYLINDER HEAD DISASSEMBLY	6-7	CYLINDER HEAD COVER ASSEMBLY/INSTALLATION	6-17

6

SERVICE INFORMATION

GENERAL

- This section covers the cylinder head, valves, camshaft, rocker arm and cam chain tensioner lifter services. The camshaft and rocker arm services can be performed with the engine in the frame.
- Camshaft lubrication oil is fed to the cylinder head through an oil pipe. Be sure this pipe is not clogged before installation.
- Before assembly, apply molybdenum disulfide grease to the camshaft bearings to provide initial lubrication.
- Pour clean engine oil into the oil pockets in the cylinder head during assembly to lubricate the camshaft lobes.

SPECIFICATIONS

ITEM			STANDARD	SERVICE LIMIT
Cylinder compression			1,250 ± 100 kPa (12.5 ± 1.0 kg/cm ² , 178 ± 14.2 psi)	—
Camshaft	Cam height	IN	36.096 mm (1.4211 in)	35.916 mm (1.4140 in)
		EX	35.889 mm (1.4129 in)	35.709 mm (1.4059 in)
	Journal O.D.	R	23.954 – 23.975 mm (0.9431 – 0.9439 in)	23.90 mm (0.941 in)
		C	23.934 – 23.955 mm (0.9423 – 0.9431 in)	23.88 mm (0.940 in)
		L	19.954 – 19.975 mm (0.7856 – 0.7864 in)	19.90 mm (0.784 in)
	Bearing I.D.	R, C	24.000 – 24.021 mm (0.9449 – 0.9457 in)	24.05 mm (0.947 in)
		L	20.000 – 20.021 mm (0.7874 – 0.7882 in)	20.05 mm (0.789 in)
	Oil clearance	R, L	0.025 – 0.067 mm (0.0010 – 0.0026 in)	0.10 mm (0.004 in)
C		0.045 – 0.087 mm (0.0018 – 0.0034 in)	0.12 mm (0.005 in)	
Cylinder head warp			—	0.10 mm (0.004 in)
Rocker arm	I.D.		11.988 – 12.006 mm (0.4720 – 0.4727 in)	12.038 mm (0.4739 in)
	Shaft O.D.		11.966 – 11.984 mm (0.4711 – 0.4718 in)	11.92 mm (0.469 in)
	Arm-to-shaft clearance		0.004 – 0.040 mm (0.0002 – 0.0016 in)	0.068 mm (0.0027 in)
Valve spring	Free length	Inner	35.15 mm (1.384 in)	32.2 mm (1.27 in)
		Outer	39.29 mm (1.547 in)	36.3 mm (1.43 in)
	Preload	Inner	6.3 ± 0.6 kg/26.8 mm (13.89 ± 1.32 lb/1.06 in)	—
		Outer	16 ± 1.6 kg/30.8 mm (35.28 ± 3.53 lb/1.21 in)	—
Valve, valve guide	Stem O.D.	IN	5.480 – 5.490 mm (0.2157 – 0.2161 in)	5.45 mm (0.215 in)
		EX	5.460 – 5.470 mm (0.2150 – 0.2154 in)	5.43 mm (0.214 in)
	Guide I.D.	IN	5.500 – 5.512 mm (0.2165 – 0.2170 in)	5.525 mm (0.2175 in)
		EX	5.500 – 5.512 mm (0.2165 – 0.2170 in)	5.525 mm (0.2175 in)
	Stem-to-guide clearance	IN	0.010 – 0.032 mm (0.0004 – 0.0012 in)	0.12 mm (0.005 in)
		EX	0.030 – 0.052 mm (0.0012 – 0.0020 in)	0.14 mm (0.006 in)
Valve seat width			1.2 mm (0.05 in)	1.5 mm (0.06 in)

CYLINDER HEAD/VALVES

TORQUE VALUES

Cylinder head cap nuts	35–45 N·m (3.5–4.5 kg-m, 25–32 ft-lb)
Cylinder head bolts	35–45 N·m (3.5–4.5 kg-m, 25–32 ft-lb)
Cam sprocket bolts	17–23 N·m (1.7–2.3 kg-m, 12–17 ft-lb)
Valve adjusting screw lock nuts	15–18 N·m (1.5–1.8 kg-m, 11–13 ft-lb)
Oil bolts	12–16 N·m (1.2–1.6 kg-m, 9–12 ft-lb)
Spark plug	15–20 N·m (1.5–2.0 kg-m, 11–15 ft-lb)
Cam chain tensioner lifter sealing bolt	8–12 N·m (0.8–1.2 kg-m, 6–9 ft-lb)
Cam chain tensioner lifter SH bolts	8–12 N·m (0.8–1.2 kg-m, 6–9 ft-lb)

TOOLS

Special

Valve guide reamer, 5.5 mm 07984–2000000

Common

Valve guide remover, 5.5 mm	07742–0010100 or 07942–3290100
Valve spring compressor	07757–0010000 or 07957–3290001
Valve seat cutter, 29 mm (EX 45°)	07780–0010300
Valve seat cutter, 33 mm (IN 45°)	07780–0010800
Valve seat cutter, 30 mm (EX 32°)	07780–0012200
Valve seat cutter, 35 mm (IN 32°)	07780–0012300
Valve seat cutter, 30 mm (EX, IN 60°)	07780–0014000
Valve seat cutter holder	07781–0010101

NOTE: Valve seat cutters are commercially available in U.S.A.

TROUBLESHOOTING

Engine top-end problems usually affect engine performance. These problems can be diagnosed by a compression test, or by tracing engine noises to the top-end with a sounding rod or stethoscope.

Low compression

- Valves:
 - Incorrect valve adjustment.
 - Burned or bent valve.
 - Incorrect valve timing.
 - Weak valve spring.
- Cylinder head:
 - Leaking or damaged head gasket.
 - Warped or cracked cylinder head.
- Cylinder and piston (Section 7).

High compression

- Excessive carbon build-up on piston crown or on combustion chamber.

Excessive noise

- Incorrect valve adjustment.
- Sticking valve or broken valve spring.
- Damaged or worn rocker arm or camshaft.
- Worn or damaged cam chain.
- Worn or damaged cam chain tensioner.
- Worn cam sprocket teeth.

Poor idling

- Compression too low.

CYLINDER HEAD COVER REMOVAL/ DISASSEMBLY

REMOVAL

Remove the fuel tank (page 4-3).

Remove the upper engine hanger plate bolts and the plates.

Disconnect the decompressor cable from the upper arm.

Remove the oil bolt with the two sealing washers.
Remove the valve adjusting hole covers.

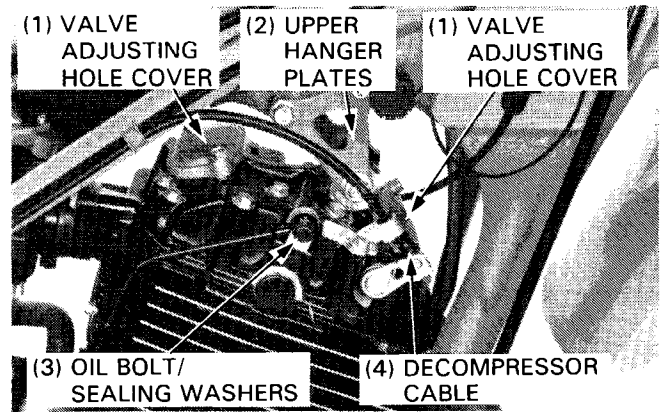

Remove the cylinder head cover bolts, cover and dowel pins.

NOTE

- Loosen the bolts in 2 or 3 steps in a crisscross pattern, starting with the center bolt.

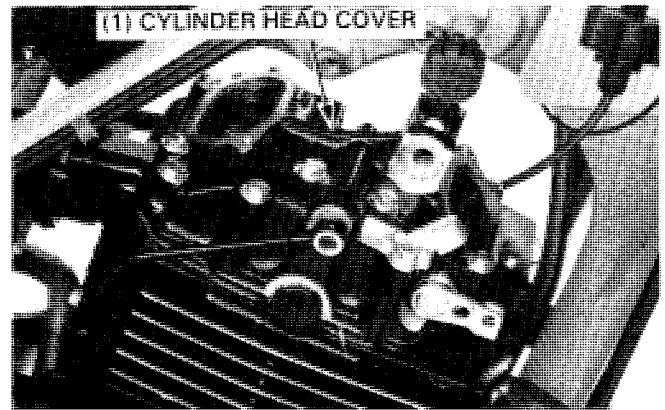

DISASSEMBLY

Remove the dowel pin and the decompressor shaft.

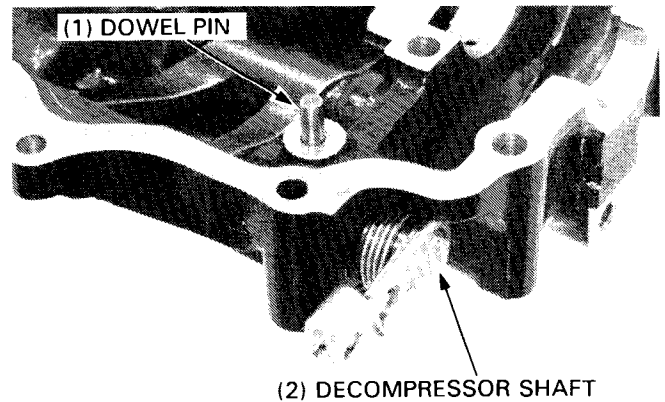

Groove each rocker arm shaft dowel pin with a grinder and drive the dowel pins out using a screwdriver as shown.

Remove the rocker arm shafts and rocker arms from the cylinder head cover.

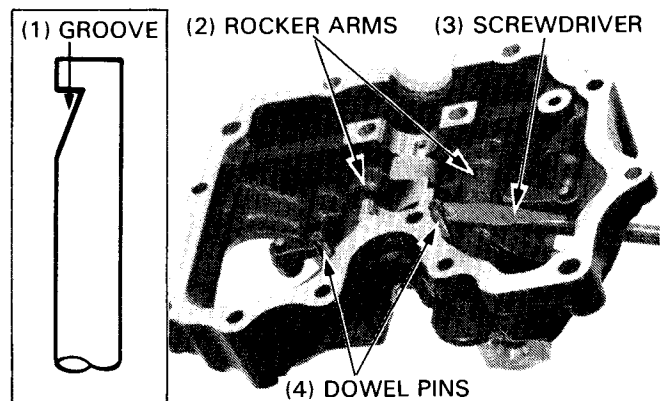

CYLINDER HEAD/VALVES

ROCKER ARM/SHAFT INSPECTION

Inspect the rocker arms and shafts for wear or damage.

NOTE

- If any rocker arm requires servicing or replacement, inspect the cam lobes for scoring, chipping or flat spots.

Measure the I.D. of each rocker arm.

SERVICE LIMIT: 12.038 mm (0.4739 in)

Measure the O.D. of each rocker arm shaft.

SERVICE LIMIT: 11.92 mm (0.469 in)

Calculate rocker arm-to-shaft clearance.

SERVICE LIMIT: 0.068 mm (0.0027 in)

CAM CHAIN TENSIONER LIFTER DISASSEMBLY

Remove the two bolts attaching the cam chain tensioner lifter and the lifter

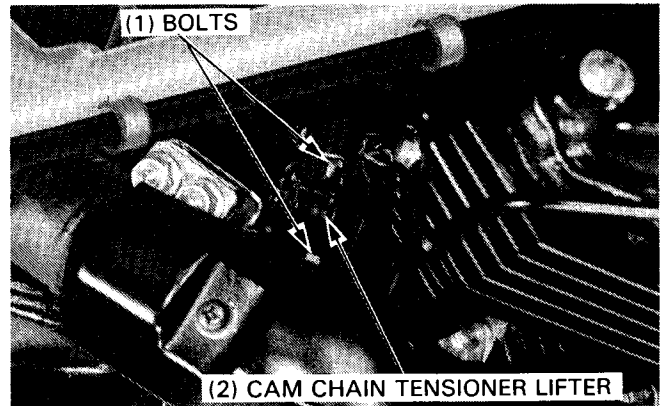
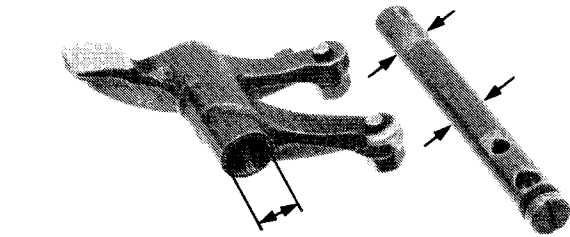

Remove the two screws assembling the cam chain tensioner lifter and disassemble the lifter.

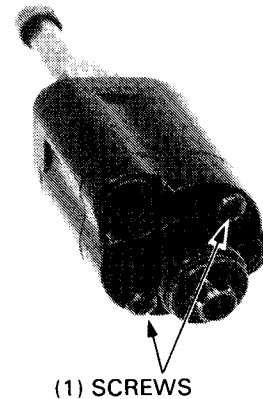

INSPECTION

Check all tensioner lifter parts for wear or damage and replace if necessary.

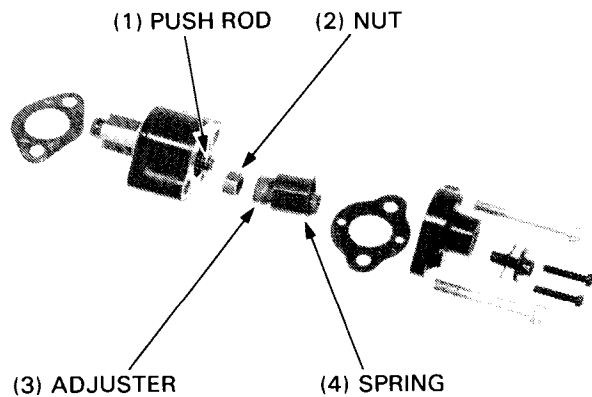

After '85:

Remove the push rod by removing the circlip.

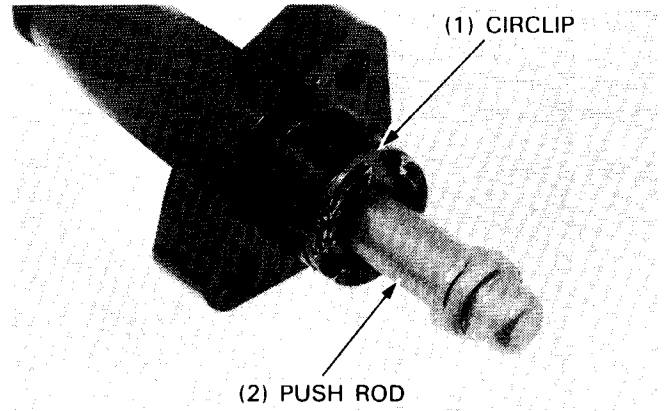

Inspect the tensioner spring for weakness or damage. Inspect the tensioner components for wear or damage and replace if necessary.

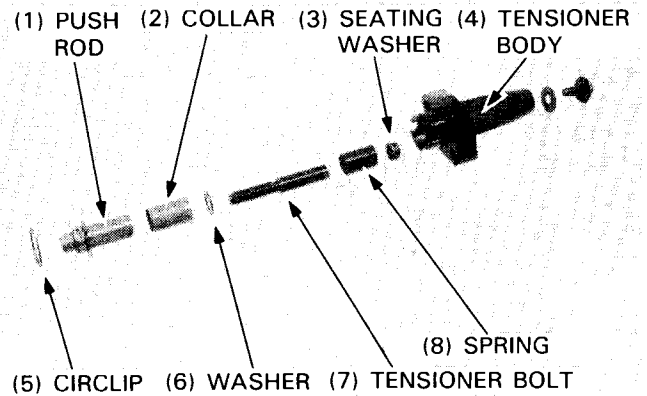

CAMSHAFT REMOVAL

REMOVAL

Remove the timing and flywheel bolt hole caps.

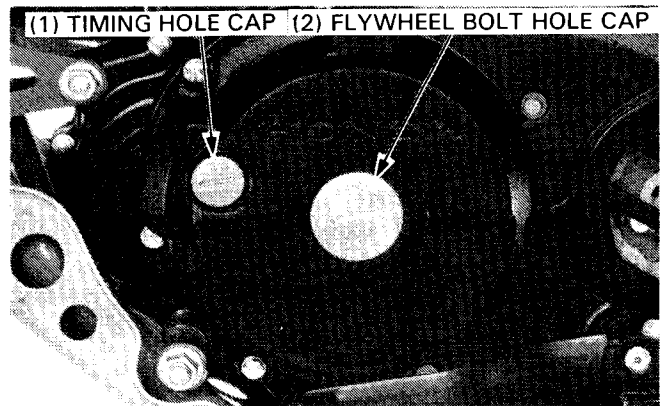

Turn the flywheel counterclockwise and remove the cam sprocket bolts and cam sprocket.

Remove the camshaft.

Suspend the cam chain with a piece of wire to prevent it from falling into the crankcase.

Remove the camshaft end cap.

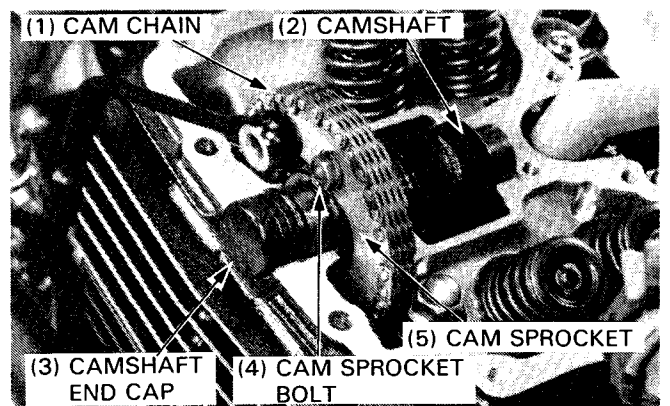

CYLINDER HEAD/VALVES

INSPECTION

Using a micrometer, measure the height of each cam lobe and inspect it for wear or damage.

SERVICE LIMITS:

INTAKE: 35.916 mm (1.4140 in)
EXHAUST: 35.709 mm (1.4059 in)

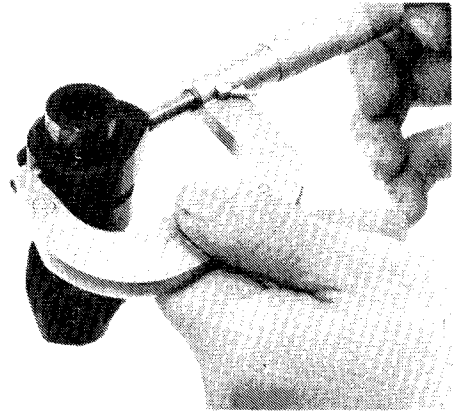

Measure the camshaft journal O.D.

SERVICE LIMIT:

LEFT: 19.90 mm (0.784 in)
CENTER: 23.88 mm (0.940 in)
RIGHT: 23.90 mm (0.941 in)

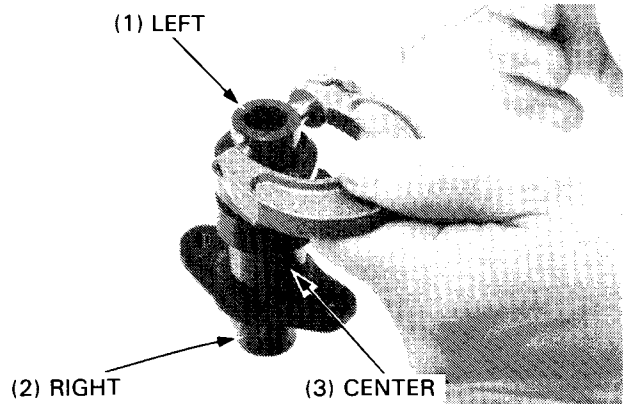

Install the cylinder head cover and tighten the cover bolts in a crisscross pattern in 2 to 3 steps.

Measure the camshaft journal bearing I.D.

SERVICE LIMIT:

LEFT: 20.05 mm (0.789 in)
RIGHT AND CENTER: 24.05 mm (0.947 in)

Calculate camshaft-to-bearing clearance.

SERVICE LIMIT:

LEFT AND RIGHT: 0.10 mm (0.004 in)
CENTER: 0.12 mm (0.005 in)

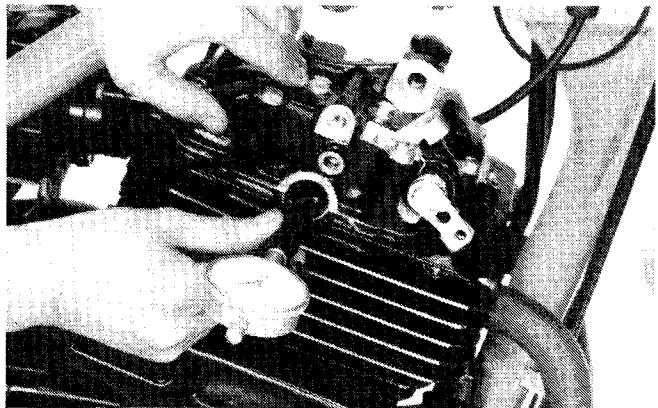

CYLINDER HEAD REMOVAL

Remove the engine from the frame (page 5-2).
Remove the oil pipe mount bolt, oil bolts, sealing washers and oil pipe.

Remove the cylinder head cover (page 6-3) and the camshaft (page 6-5).

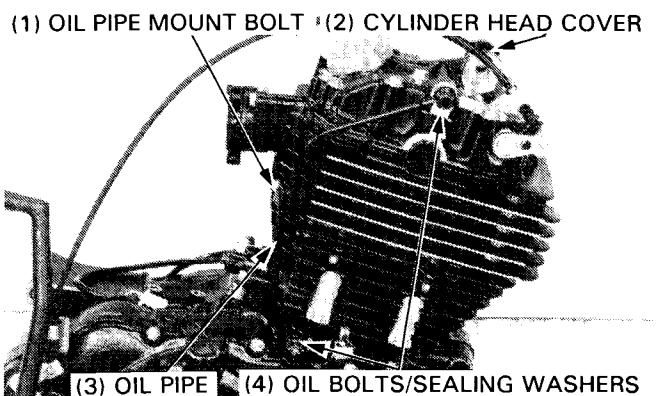

Remove the cylinder head cap nuts and bolts in a crisscross pattern in 2 or 3 steps.

Remove the cylinder head.

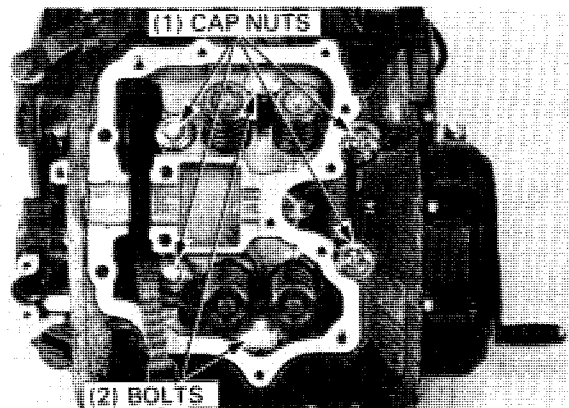

Remove the cylinder head gasket and dowel pins.

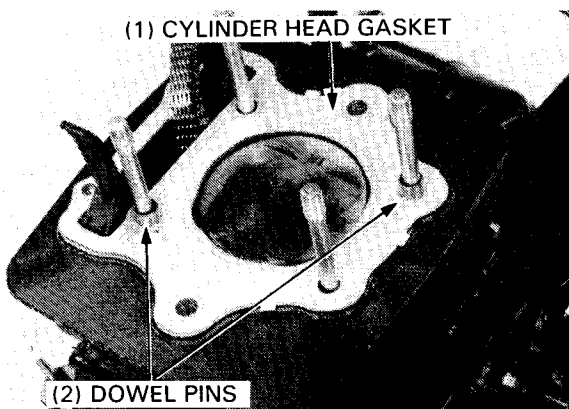

CYLINDER HEAD DISASSEMBLY

Remove the valve spring cotters, retainers, springs and valves with the Valve Spring Compressor.

CAUTION

- To prevent loss of tension, do not compress the valve springs more than necessary to remove the cotters.

NOTE

- Mark all parts during disassembly so they can be placed back in their original locations.

Remove the valve stem seals and spring seats.

INSPECTION

● CYLINDER HEAD

Remove carbon deposits from the combustion chamber. Clean off any gasket material from the cylinder head surface. Check the spark plug hole and valve areas for cracks. Check the cylinder head for warpage with a straight edge and feeler gauge.

SERVICE LIMIT: 0.10 mm (0.004 in)

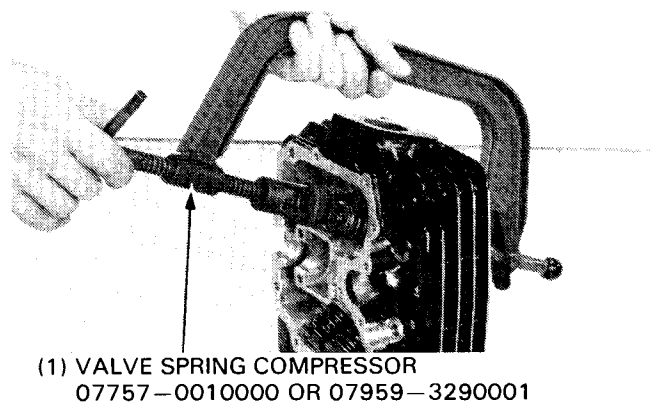

CYLINDER HEAD/VALVES

● VALVE SPRINGS

Measure the free length of the inner and outer valve springs.

SERVICE LIMITS:

INNER (IN): 32.2 mm (1.27 in)

(EX): 32.2 mm (1.27 in)

OUTER (IN): 36.3 mm (1.43 in)

(EX): 36.3 mm (1.43 in)

Replace the springs if they are shorter than the service limits.

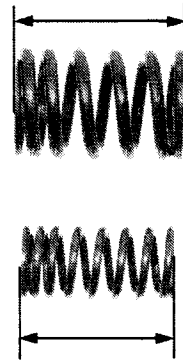

● VALVE STEM-TO-GUIDE CLEARANCE

Inspect each valve for bending, burning or abnormal stem wear.

Check valve movement in the guide and measure and record each valve stem O.D.

SERVICE LIMITS: IN : 5.45 mm (0.215 in)

EX: 5.43 mm (0.214 in)

NOTE

- Ream the guides to remove any carbon deposits before checking clearances.

Measure and record each valve guide I.D.

SERVICE LIMIT: 5.525 mm (0.2175 in)

Subtract each valve stem O.D. from the corresponding guide I.D. to obtain the stem to guide clearance.

SERVICE LIMITS: IN: 0.12 mm (0.005 in)

EX: 0.14 mm (0.006 in)

If the stem-to-guide clearance exceeds the service limits, determine if a new guide with standard dimensions would bring the clearance within tolerance. If so, replace any guides as necessary and ream to fit.

If the stem-to-guide clearance exceeds the service limits with new guides also, replace the valves.

NOTE

- Reface the valve seats whenever the valve guides are replaced.

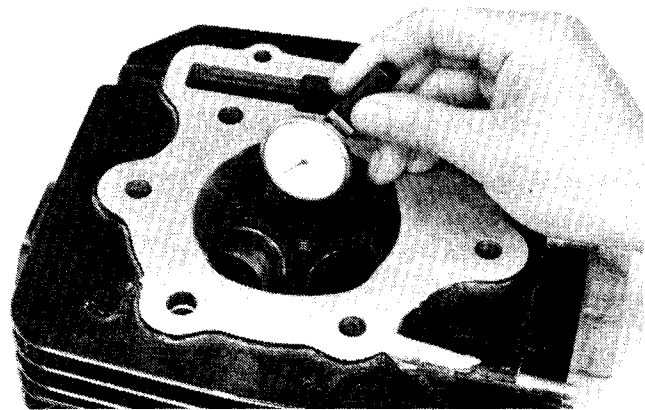
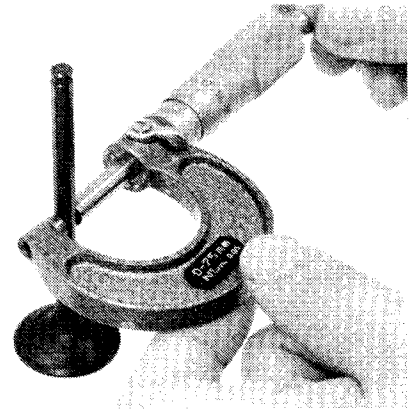

(1) VALVE GUIDE REMOVER
07742-0010100 OR 07942-3290100

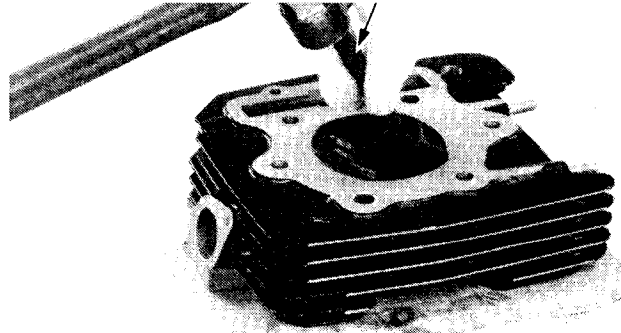

VALVE GUIDE REPLACEMENT

Heat the cylinder head to 100°C (212°F) with a hot plate or oven.

WARNING

- *To avoid burns, wear heavy gloves when handling the heated cylinder head.*

CAUTION

- *Do not use a torch to heat the cylinder head; it may cause warping.*

Support the cylinder head and drive out the old guides from the combustion chamber side of the cylinder head.

CAUTION

- *Avoid damaging the cylinder head.*

Place a new O-ring on the new valve guide. Drive in the guide from the top of the head.

Check to be sure the new guide was not damaged during installation, then ream the guide.

NOTE

- Use cutting oil on the reamer during this operation.
- Always rotate the reamer in the same direction.

Clean the cylinder head thoroughly to remove any metal particles.

Reface the valve seat (page 6-9).

VALVE SEAT INSPECTION/REFACING

INSPECTION

Clean all intake and exhaust valves thoroughly to remove carbon deposits.

Apply a light coating of Prussian Blue to each valve seat. Lap each valve and seat using a rubber hose or other hand-lapping tool.

Remove and inspect each valve.

CAUTION

- *The valve cannot be ground. If the valve face is burned or badly worn or if it contacts the seat unevenly, replace the valve.*

Inspect the width of each valve seat.

STANDARD: 1.2 mm (0.05 in)

SERVICE LIMIT: 1.5 mm (0.06 in)

If the seat is too wide, too narrow or has low spots, the seat must be ground.

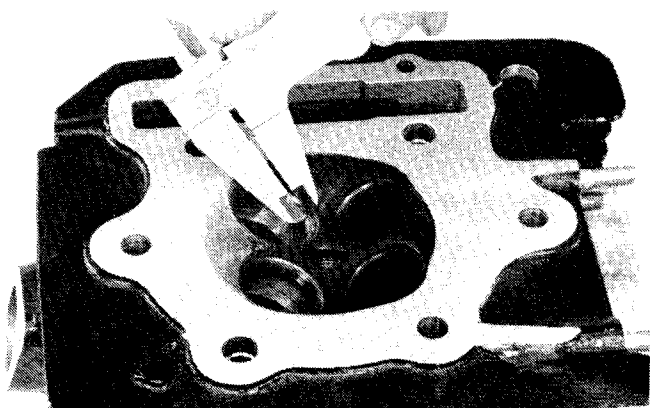
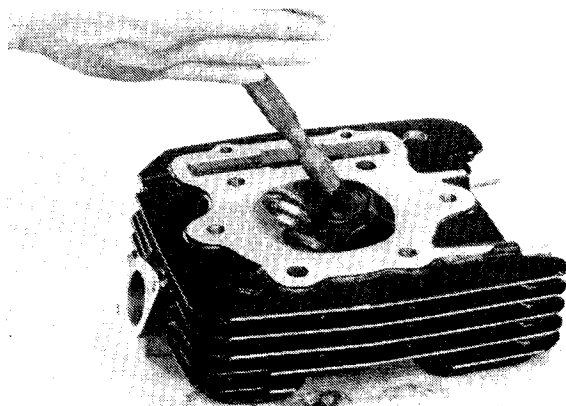
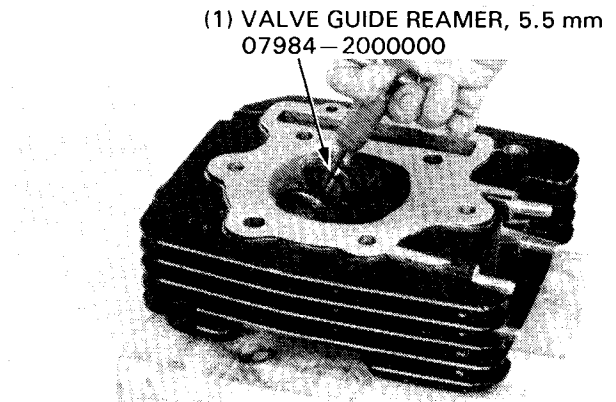
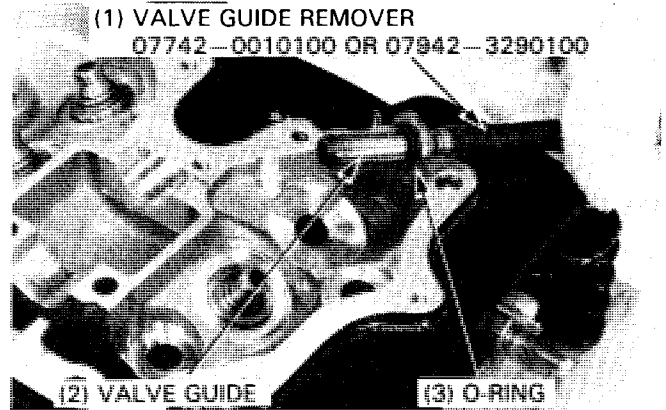

CYLINDER HEAD/VALVES

Honda Valve Seat Cutters, a grinder or equivalent valve seat refacing equipment are recommended to correct a worn valve seat.

NOTE

- Follow the refacer manufacturer's operating instructions.

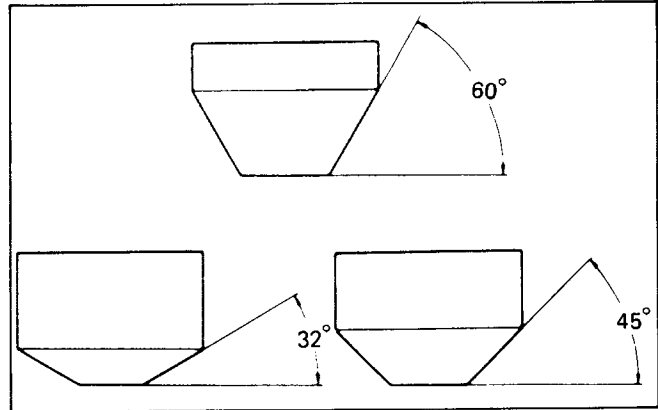

REFACING

Use a 45 degree cutter to remove any roughness or irregularities from the seat.

NOTE

- Reface the seat with a 45 degree cutter when a valve guide is replaced.

Use a 32 degree cutter to remove the top 1/4 of the existing valve seat material.

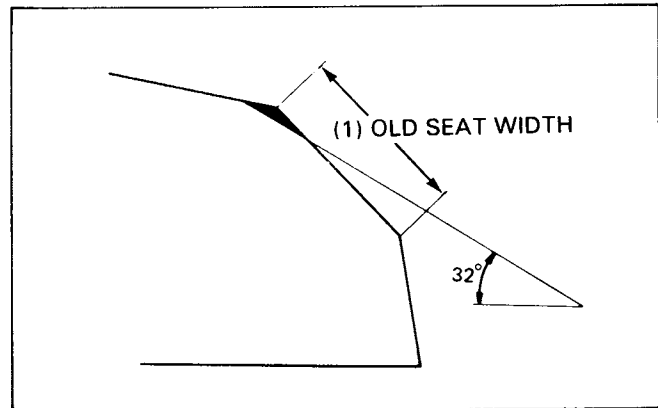

Use a 60 degree cutter to remove the bottom 1/4 of the old seat. Remove the cutter and inspect the area you have refaced.

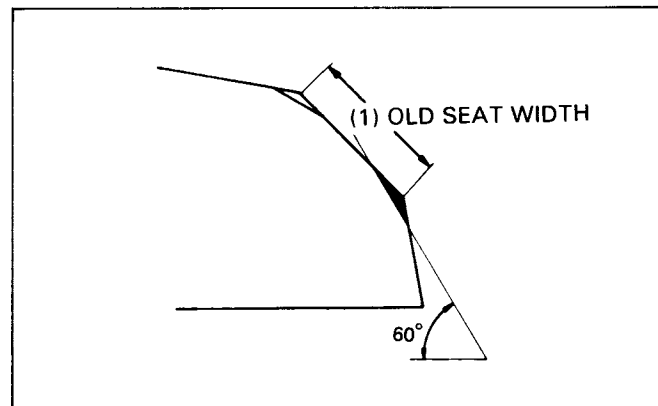

Install a 45 degree finish cutter and cut the seat to the proper width. Make sure that all pitting and irregularities are removed. Refinish if necessary.

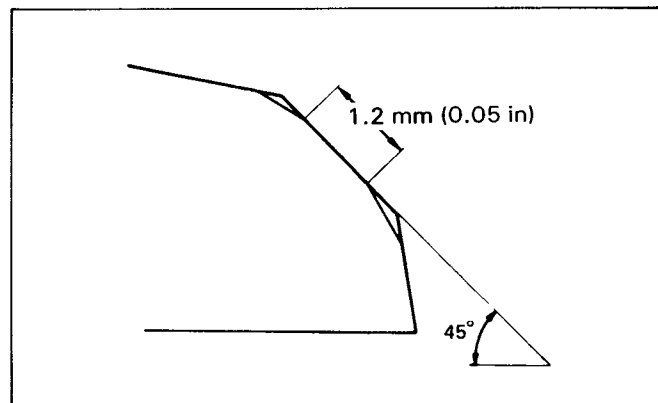

Apply a thin coating of Prussian Blue to the valve seat. Press the valve through the valve guide and onto the seat to make a clear pattern.

NOTE

- The location of the valve seat in relation to the valve face is very important for good sealing.

If the contact area is too high on the valve, the seat must be lowered using a 32 degree flat cutter.

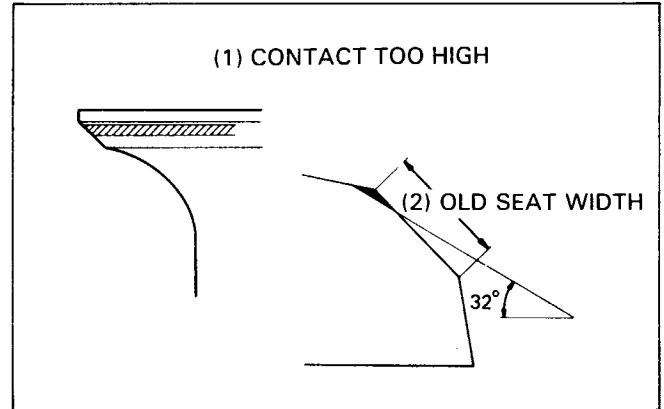

If the contact area is too low on the valve, the seat must be raised using a 60 degree inner cutter.

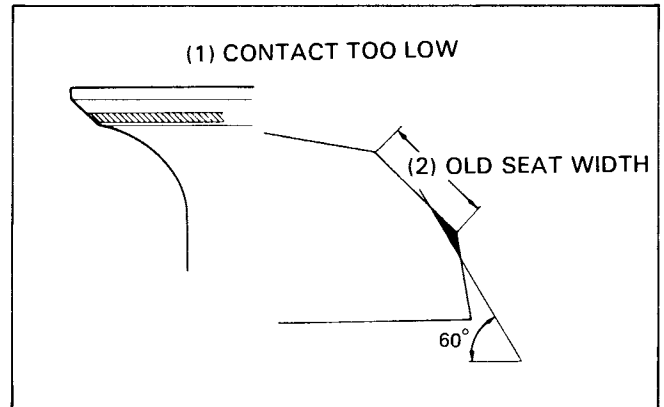

Refinish the seat to specifications, using a 45 degree finish cutter.

After cutting the seat, apply lapping compound to the valve face, and lap the valve using light pressure.

After lapping, wash all residual compound off the cylinder head and valve.

NOTE

- Do not allow lapping compound to enter the guides.

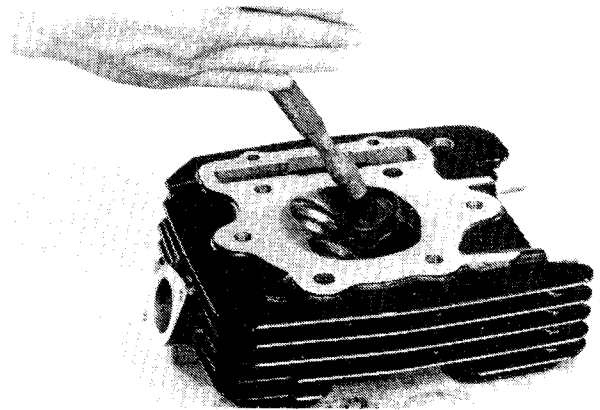

CAM CHAIN TENSIONER

REMOVAL

Remove the following:

- cylinder head cover (page 6-3)
- cam chain tensioner lifter (page 6-4)
- camshaft (page 6-5)
- cylinder head (page 6-6)
- right crankcase cover (page 8-3)
- clutch (page 8-6)
- tensioner guide
- tensioner mount bolt and tensioner.

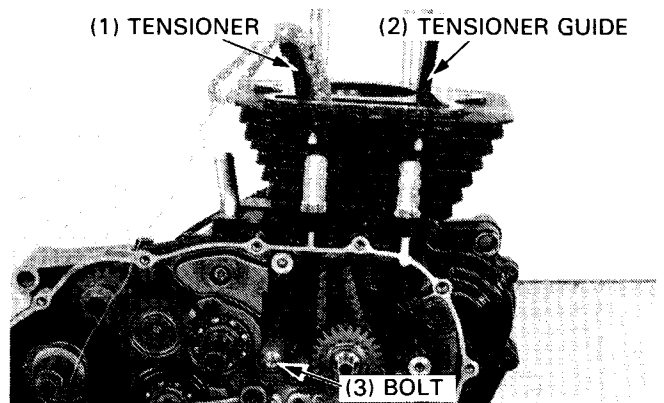

CYLINDER HEAD/VALVES

INSPECTION

Inspect the cam chain tensioner guide and tensioner for wear or damage.

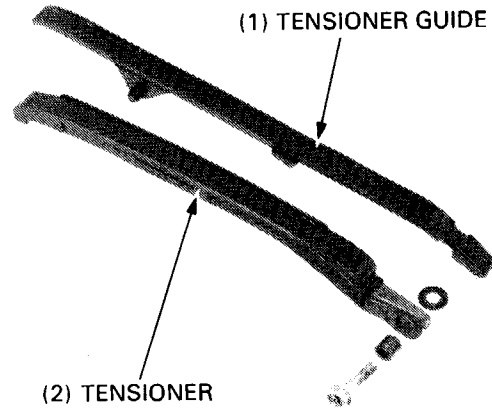

INSTALLATION

Install the tensioner, washer and collar and tighten the bolt. Install the tensioner guide aligning its lower end with the groove in the crankcase, and its bosses with the grooves in the cylinder upper surface.

Install the removed parts in the reverse order of removal.

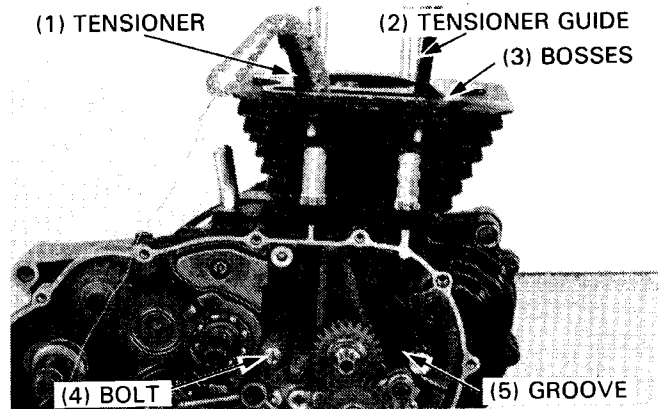

CYLINDER HEAD ASSEMBLY

Install the valve spring seat and a new stem seal.

Lubricate each valve stem with molybdenum disulfide grease and insert the valve into the valve guide. To avoid damage to the stem seal, turn the valve slowly when inserting.

Install the valve springs with the tightly wound coils facing the cylinder head.

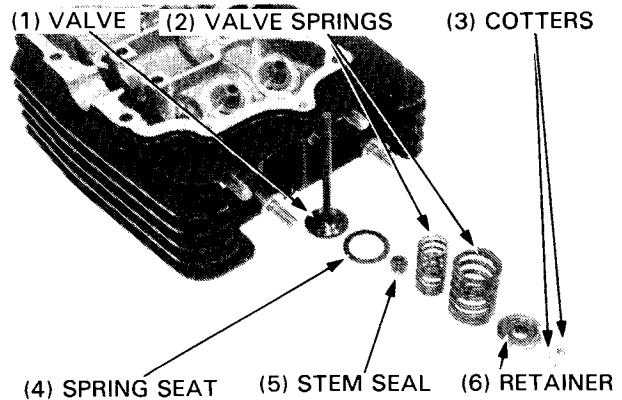

Install the valve spring retainers and the valve cotters.

CAUTION

- To prevent loss of tension, do not compress the springs more than necessary.

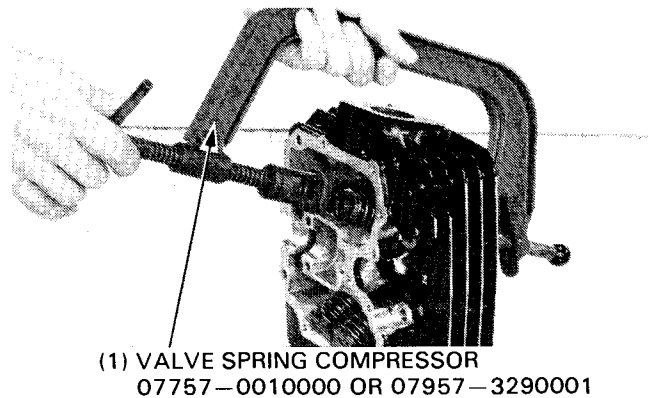

Tap the valve stems gently with a plastic hammer to firmly seat the cotters.

CAUTION

- *Support the cylinder head above the work bench surface to prevent possible valve damage.*

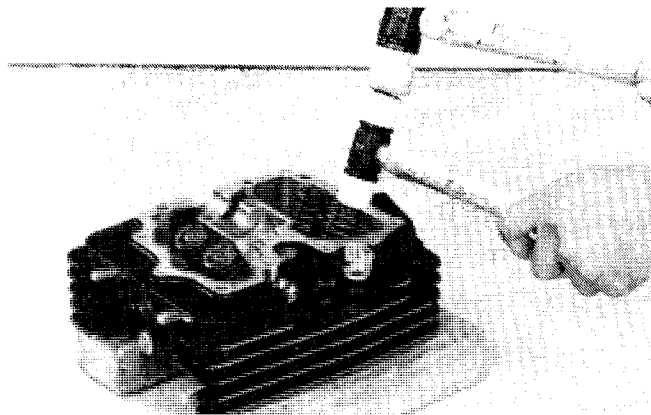

CYLINDER HEAD INSTALLATION

Make sure that the cylinder head gasket is in good condition. If it is warped or damaged, replace it with a new one.

Install the two dowel pins and the cylinder head gasket.

(1) CYLINDER HEAD GASKET

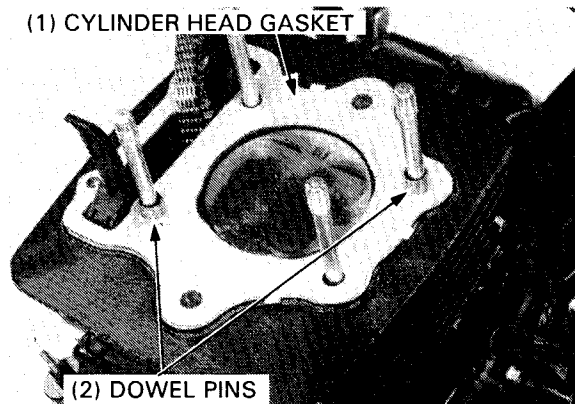

(2) DOWEL PINS

Install the cylinder head, then install the cap nuts and bolts in the sequence shown in 2 or 3 steps.

TORQUE:

- CAP NUT:** 35–45 N·m
(3.5–4.5 kg-m, 25–32 ft-lb)
- BOLT:** 35–45 N·m
(3.5–4.5 kg-m, 25–32 ft-lb)

Install the camshaft and the cylinder head cover.

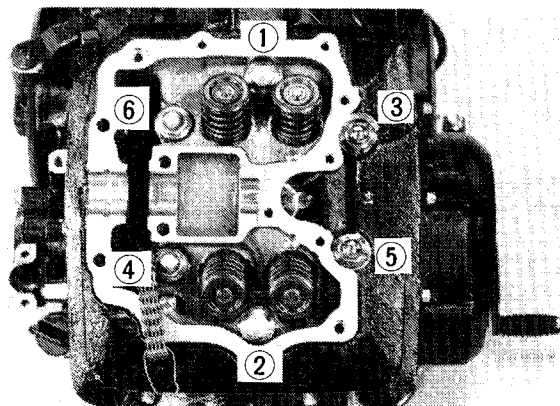

Make sure that the oil pipe and oil bolts are not clogged and the sealing washers are in good condition.

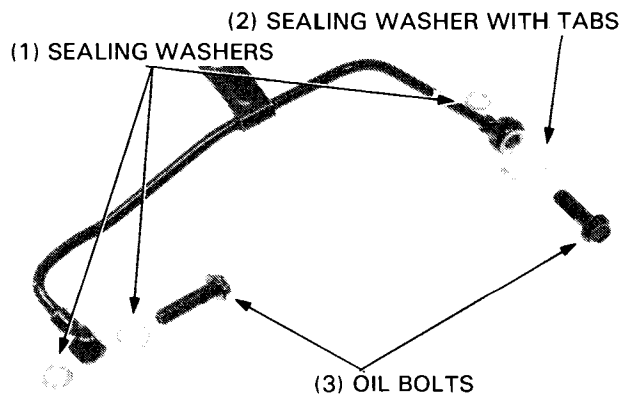

CYLINDER HEAD/VALVES

Install the oil pipe, oil bolts, sealing washers and 6 mm bolt.

TORQUE:

OIL BOLT: 12–16 N·m (1.2–1.6 kg-m, 9–12 ft-lb)

Install the engine (page 5-3).

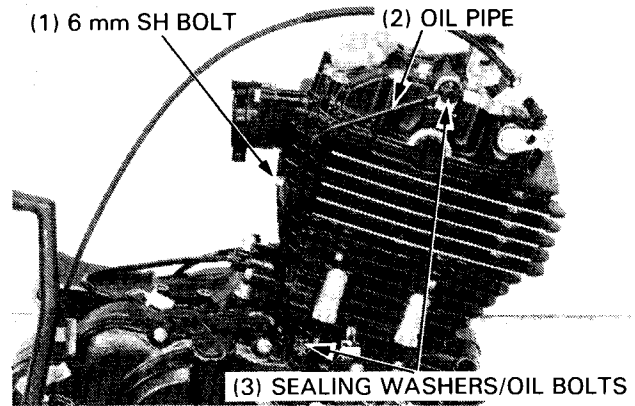

CAMSHAFT INSTALLATION

Align the "T" mark on the flywheel with the index mark on the alternator cover by turning the flywheel counterclockwise.

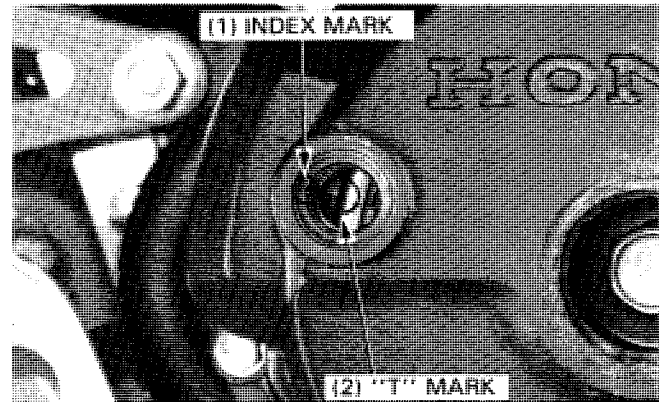

Apply molybdenum disulfide grease to the camshaft journals.

Install the cam sprocket with its punch mark facing up and install the camshaft and end cap.

Position the cam lobes down and align the timing marks on the cam sprocket with the cylinder head upper surface.

Install the cam chain over the cam sprocket and the cam sprocket onto the shoulder of the camshaft.

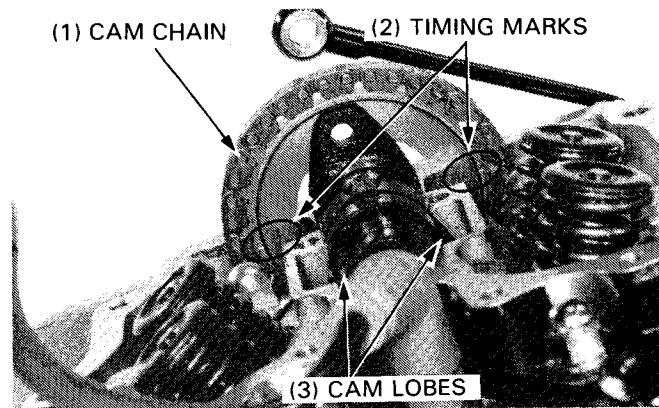

Tighten the cam sprocket bolt.

NOTE

- Tighten the punch mark side first since it is the dowel hole.

Turn the crankshaft counterclockwise one turn and tighten the remaining cam sprocket bolt to the same torque.

TORQUE: 17–23 N·m

(1.7–2.3 kg-m, 12–17 ft-lb)

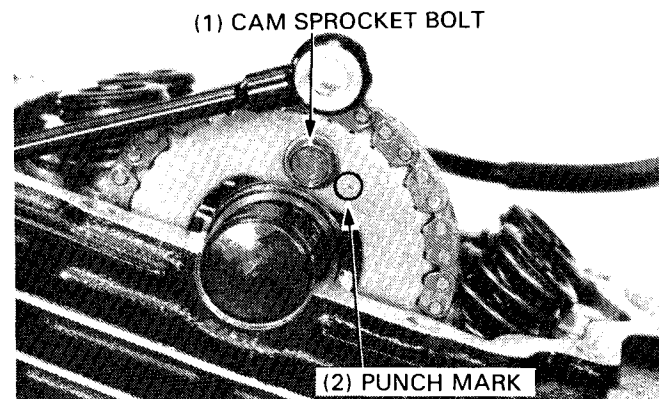

Realign the "T" mark with index mark and recheck the cam sprocket timing marks.

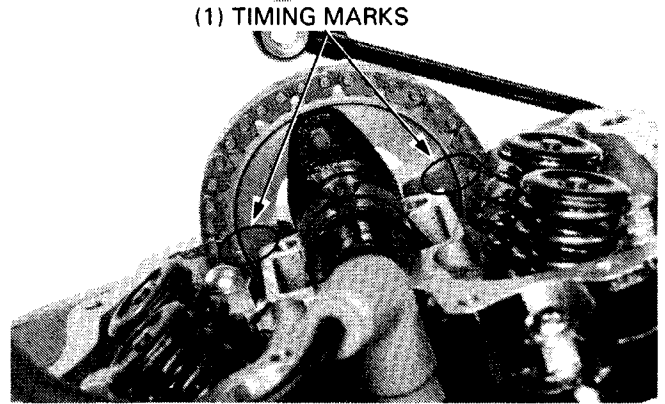

Fill the oil pocket in the cylinder head with fresh oil.

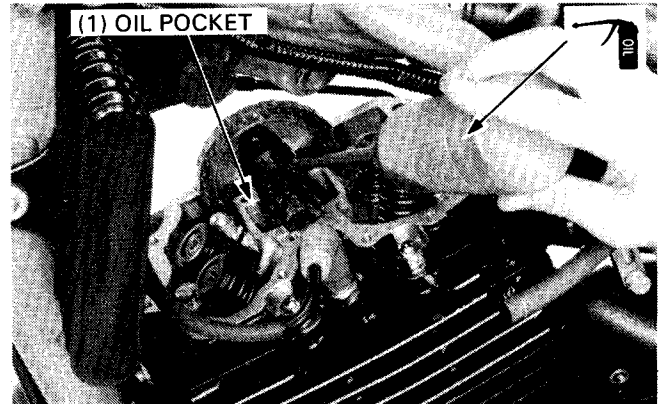

CAM CHAIN, TENSIONER LIFTER ASSEMBLY

Thread the nut on the push rod so its outside face is flush with the end of the push rod.

Hook one end of the spring into the hole in the adjuster and place the adjuster over the nut.

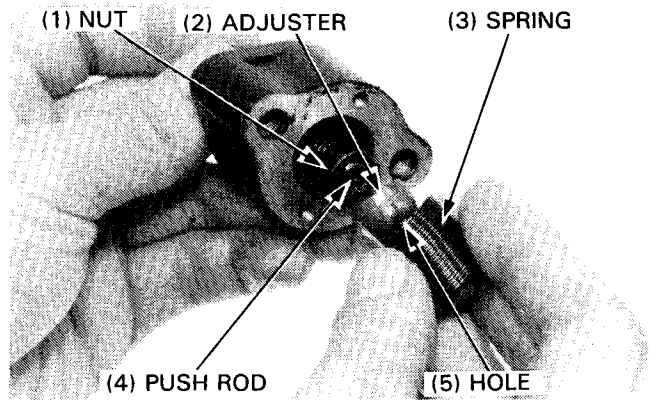

Align the spring hook with the groove in the cover and install the cover with the screws.

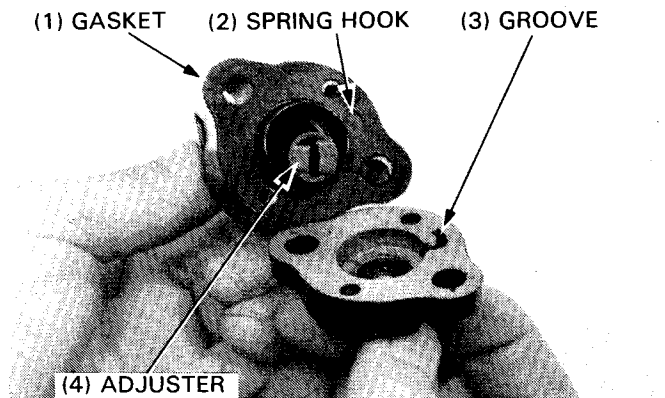

CYLINDER HEAD/VALVES

After '85:

Install the seating washer into the tensioner body.
Install the tensioner spring aligning the end of the spring with groove of the tensioner body.
Install the tensioner bolt aligning the end of the spring with groove of the tensioner bolt.

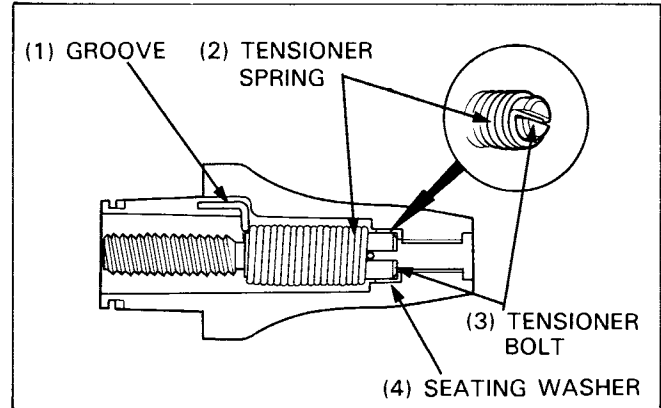

Install the collar and washer onto the push rod.
Screw in the push rod slightly and secure the push rod with the circlip.

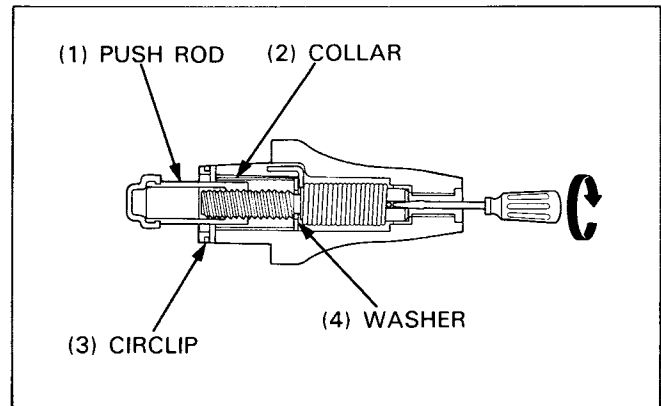

'85 and after:

Screw in the adjuster all the way through the hole in the cover and install the tensioner lifter onto the cylinder. Tighten the two tensioner lifter mount bolts and release the adjuster.

TORQUE: 8–12 N·m (0.8–1.2 kg·m, 6–9 ft·lb)

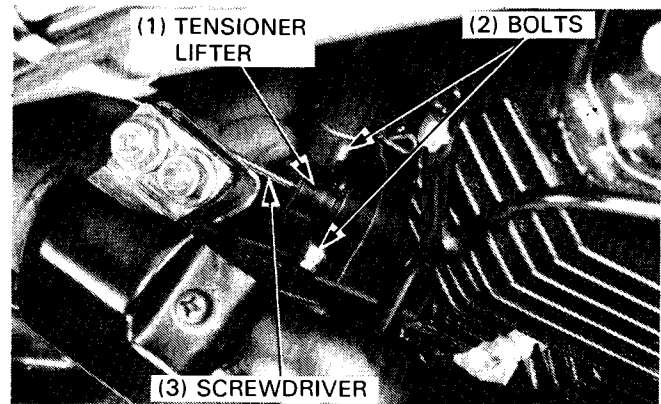

Install the sealing bolt.

TORQUE: 8–12 N·m (0.8–1.2 kg·m, 6–9 ft·lb)

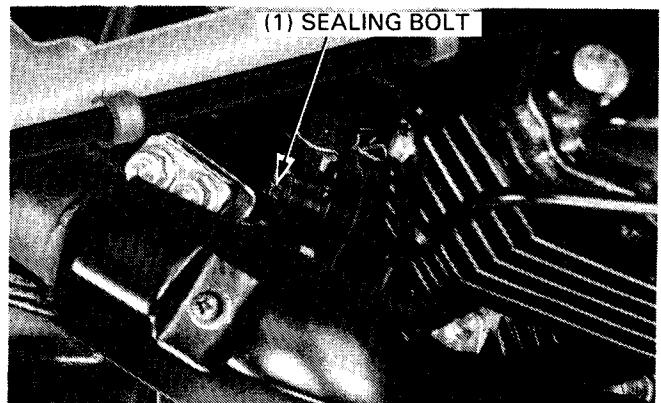

CYLINDER HEAD COVER ASSEMBLY/ INSTALLATION

ASSEMBLY

Oil the rocker arm shafts and arms.

Install new O-rings into the grooves of the rocker arm shafts and install the rocker arms and shafts aligning the cut-out in the shafts with the cover mounting bolt holes.

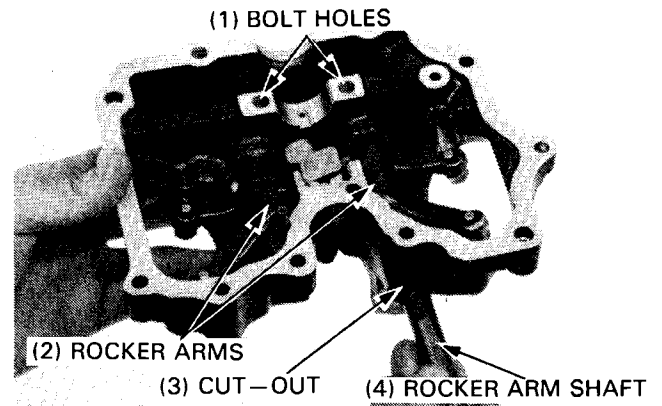

Align the dowel pin holes in the cylinder head cover and rocker arm shaft and install new dowel pins.

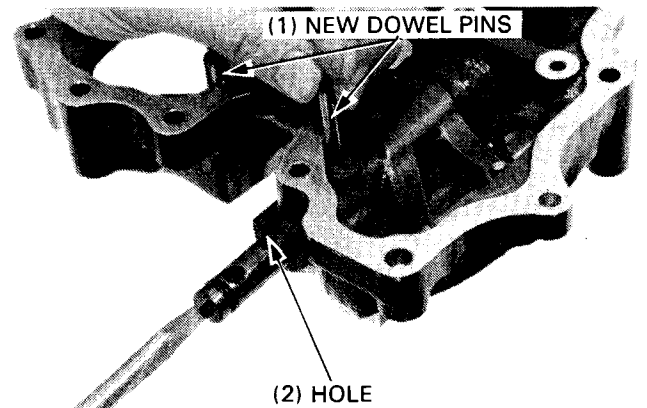

Install the decompressor shaft and spring and insert the dowel pin.

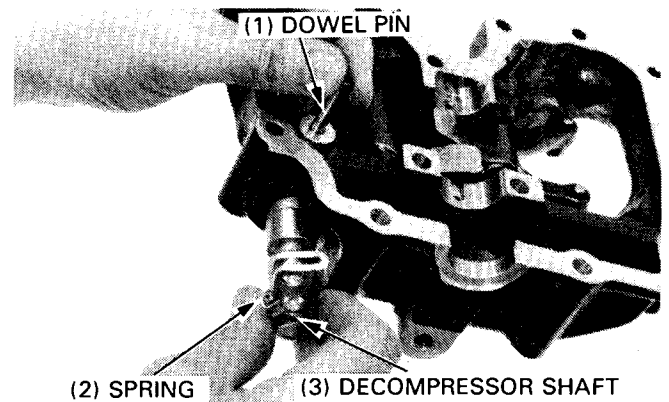

INSTALLATION

Apply liquid sealant to the mating surfaces of the cylinder head cover as shown.

NOTE

- Do not apply sealant to the camshaft bearing surfaces.

(1) DO NOT APPLY SEALANT TO THESE AREA.

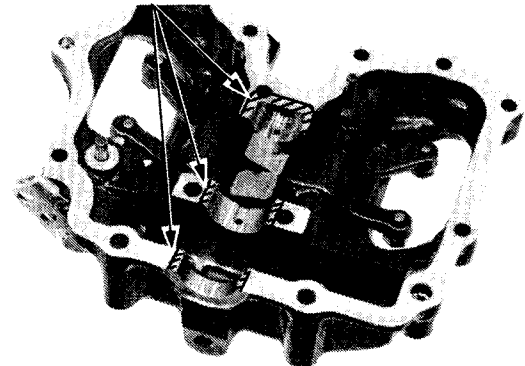

CYLINDER HEAD/VALVES

Install the two dowel pins onto the cylinder head and install the cylinder head cover.

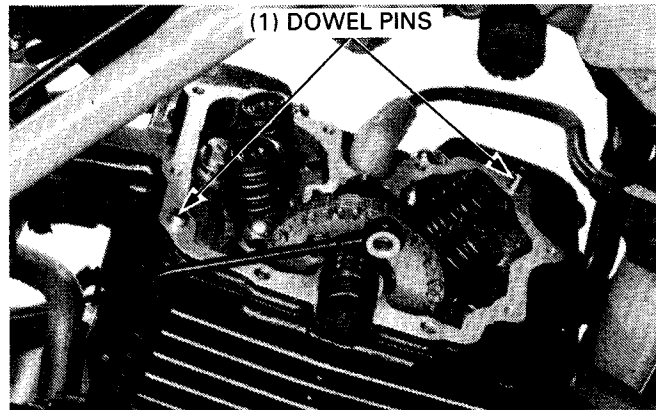

Tighten the cylinder head cover bolts in a crisscross pattern in 2 to 3 steps starting with the center bolt.

TORQUE:

7 mm BOLTS 13–17 N·m (1.3–1.7 kg-m, 9–12 ft-lb)

6 mm BOLTS 8–12 N·m (0.8–1.2 kg-m, 6–9 ft-lb)

6 mm SH BOLTS 8–12 N·m (0.8–1.2 kg-m, 6–9 ft-lb)

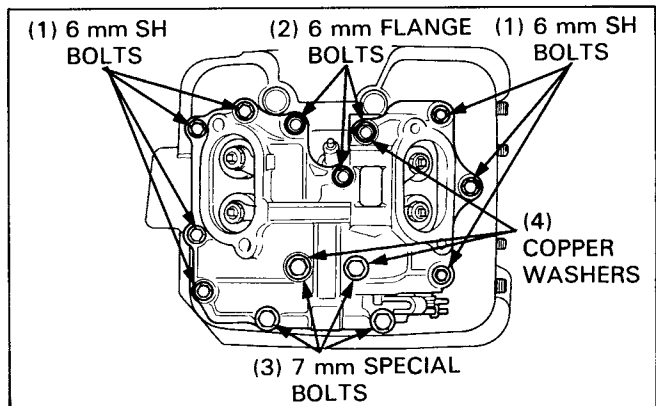

Connect the oil pipe to the cylinder head cover using the two sealing washers and oil bolt.

TORQUE: 12–16 N·m (1.2–1.6 kg-m, 9–12 ft-lb)

Make sure the sealing washers are in good condition.

NOTE

- The outside sealing washer has the locking tabs (page 6-13).

Install the upper engine hanger plates using the three bolts and nuts.

TORQUE:

10 mm BOLT 55–65 N·m (5.5–6.5 kg-m, 40–48 ft-lb)

8 mm BOLTS 24–35 N·m (2.4–3.5 kg-m, 18–25 ft-lb)

Connect the decompressor cable to the arm and adjust the cable (page 3-6).

Adjust valve clearance (page 3-5).

Test cylinder compression (page 3-9).

Install the fuel tank (page 4-3) and seat/rear fender (page 15-1).

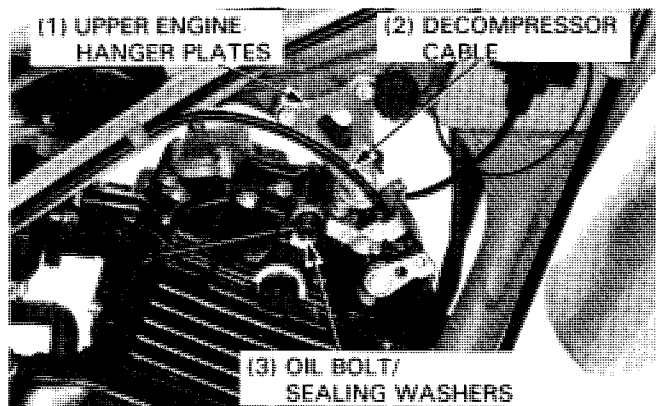

MEMO

CYLINDER/PISTON

8 – 12 N·m
(0.8 – 1.2 kg-m,
6 – 9 ft-lb)

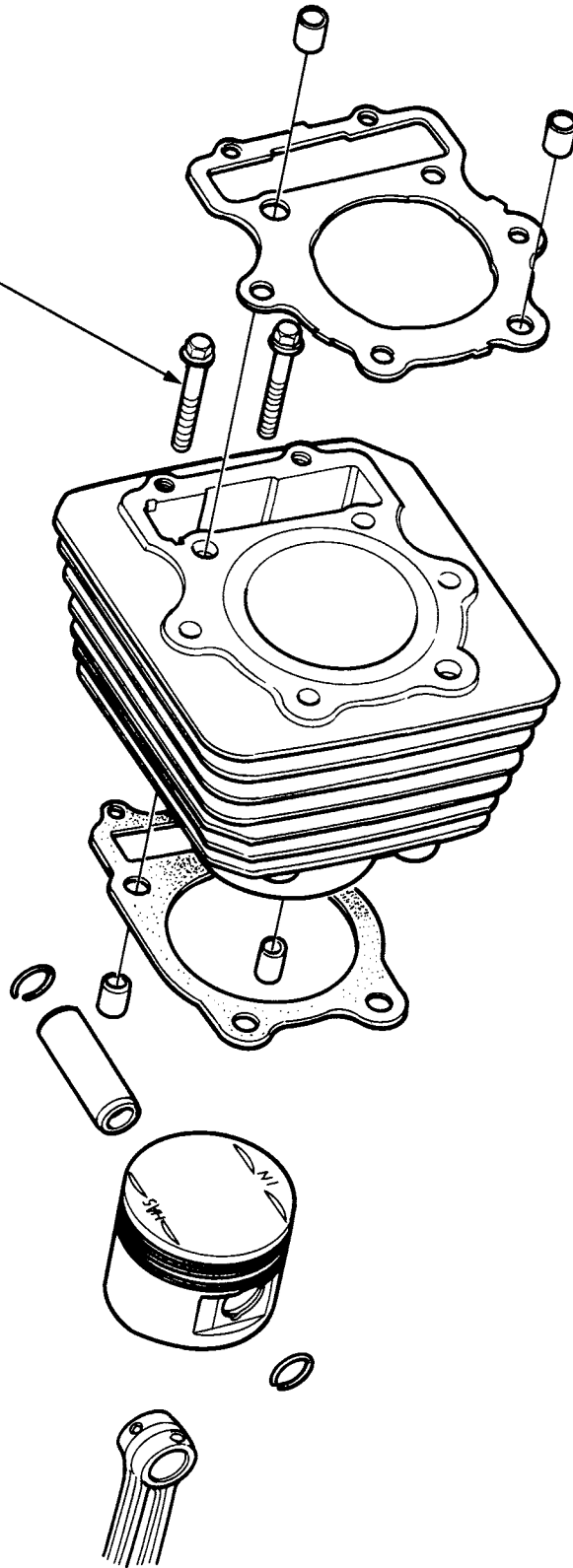

7. CYLINDER/PISTON

SERVICE INFORMATION	7-1	PISTON REMOVAL	7-3
TROUBLESHOOTING	7-1	PISTON INSTALLATION	7-5
CYLINDER REMOVAL	7-2	CYLINDER INSTALLATION	7-6

SERVICE INFORMATION

GENERAL

- This section covers cylinder and piston services. The engine must be removed from the frame to service the cylinder and piston (section 5).

SPECIFICATIONS

ITEM		STANDARD	SERVICE LIMIT	
Cylinder	I.D.	81.000–81.010 mm (3.1890–3.1894 in)	81.10 mm (3.193 in)	
	Taper	—	0.10 mm (0.004 in)	
	Out of round	—	0.10 mm (0.004 in)	
	Warpage across top	—	0.10 mm (0.004 in)	
Piston,	Piston O.D.	80.965–80.985 mm (3.1876–3.1884 in)	80.90 mm (3.185 in)	
Piston pin,	Piston pin bore	21.002–21.008 mm (0.8268–0.8271 in)	21.04 mm (0.828 in)	
Piston rings	Piston pin O.D.	20.000–20.994 mm (0.7874–0.8265 in)	20.96 mm (0.825 in)	
	Piston-to-pin clearance		0.002–0.014 mm (0.0001–0.0006 in)	
	Piston ring-to-ring groove clearance	TOP	0.015–0.045 mm (0.0006–0.0018 in)	0.09 mm (0.004 in)
		SECOND	0.015–0.045 mm (0.0006–0.0018 in)	0.09 mm (0.004 in)
	Piston ring end gap	TOP/SECOND	0.20–0.35 mm (0.008–0.014 in)	0.55 mm (0.022 in)
		OIL (SIDE RAIL)	0.20–0.70 mm (0.008–0.028 in)	—
Cylinder-to-piston clearance		0.015–0.045 mm (0.0006–0.0018 in)	0.10 mm (0.004 in)	
Connecting rod small end I.D.		21.020–21.041 mm (0.8276–0.8284 in)	21.10 mm (0.831 in)	

TORQUE VALUES

Cylinder base SH bolt 8–12 N·m (0.8–1.2 kg-m, 6–9 ft-lb)

TROUBLESHOOTING

Low or unstable compression

- Worn cylinder or piston rings.
- Cylinder head and valves need service (Section 6).

Excessive smoke

- Worn cylinder, piston, or piston rings.
- Improper installation of piston rings.
- Scored or scratched piston or cylinder wall.

Overheating

- Excessive carbon build-up on piston or combustion chamber wall.

Knocking or abnormal noise

- Worn piston and cylinder.
- Excessive carbon build-up.

CYLINDER/PISTON

CYLINDER REMOVAL

Remove the cylinder head (Section 6).

Remove the gasket, dowel pins, and cam chain guide.

NOTE

- Keep the cam chain from falling into the crankcase when removing the cylinder.

(1) CAM CHAIN TENSIONER GUIDE (2) GASKET

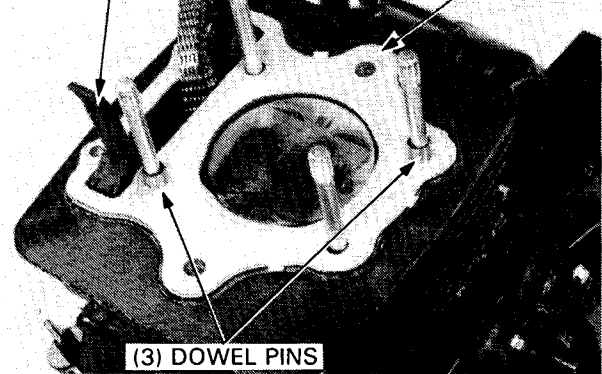

(3) DOWEL PINS

Remove the cylinder mount bolts.

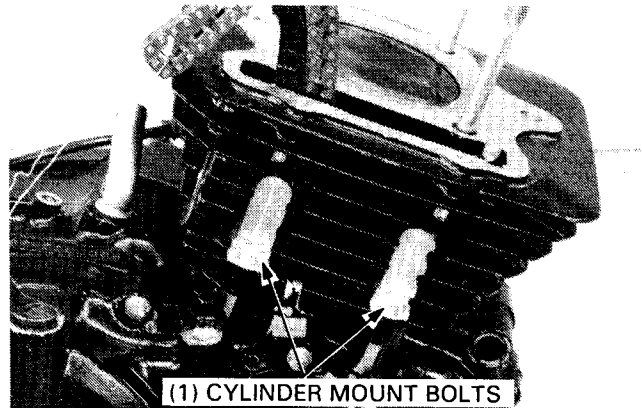

(1) CYLINDER MOUNT BOLTS

Remove the cylinder, gasket and dowel pins.



(1) GASKET

(2) DOWEL PINS

Clean off any gasket material from the cylinder surface.

NOTE

- Be careful not to damage the gasket surface.

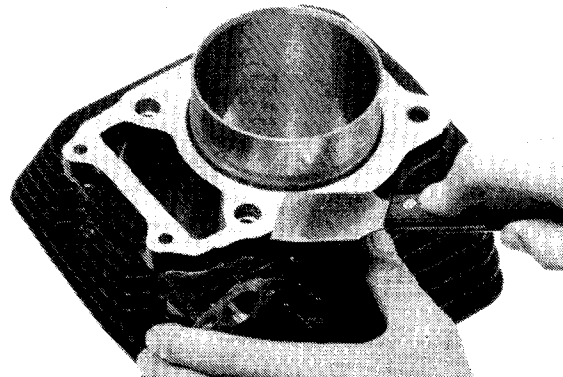

CYLINDER INSPECTION

Inspect the cylinder bore for wear or damage and measure the cylinder I.D. Check the I.D. at X and Y axis at three locations.

SERVICE LIMIT: 81.10 mm (3.193 in)

Calculate the taper and out of round.

SERVICE LIMITS:

TAPER: 0.10 mm (0.004 in)

OUT OF ROUND: 0.10 mm (0.004 in)

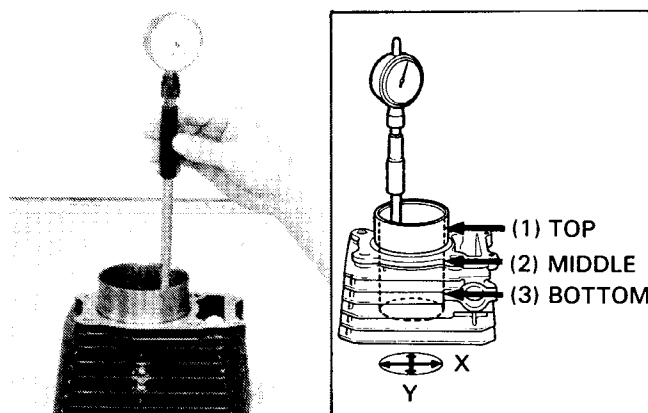

Inspect the top of the cylinder for warpage.

SERVICE LIMIT: 0.10 mm (0.004 in)

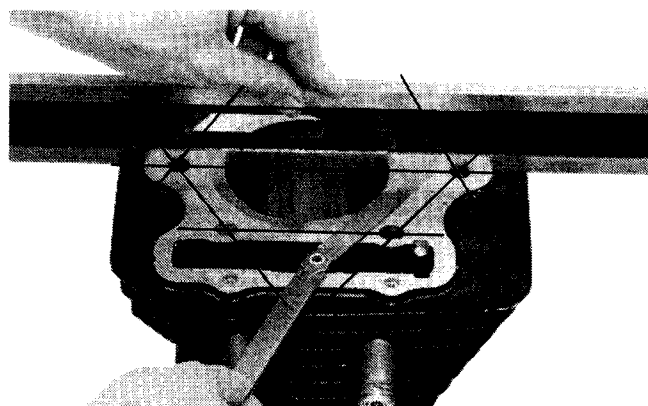

PISTON REMOVAL

Remove the piston pin clip with pliers

NOTE

- Do not let the clips fall into the crankcase.

Press the piston pin out of the piston and remove the piston.



PISTON/PISTON RING INSPECTION

Remove the piston rings.

NOTE

- Do not damage the piston rings during removal.

Measure the piston ring-to-groove clearance.

SERVICE LIMITS:

TOP: 0.09 mm (0.004 in)

SECOND: 0.09 mm (0.004 in)

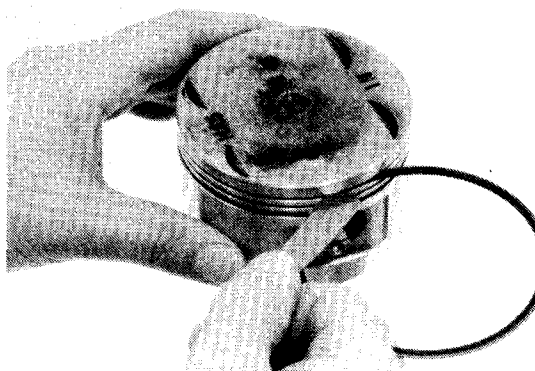

CYLINDER/PISTON

Insert each piston ring squarely into the cylinder and measure the ring end gap.

NOTE

- Push the rings into the cylinder with the top of the piston to be sure they are squarely in the cylinder.

SERVICE LIMIT:

TOP/SECOND: 0.55 mm (0.022 in)

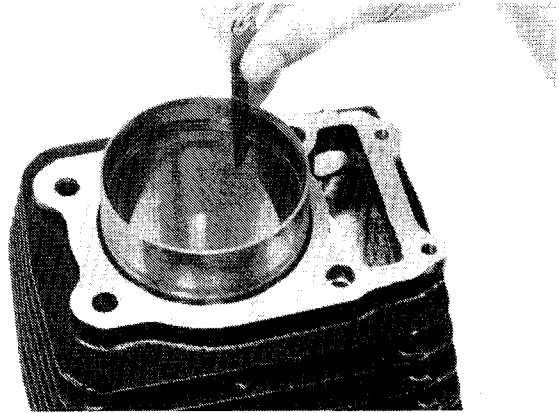

Inspect the piston for wear or damage.

Measure the diameter of the piston 10 mm from the bottom and at 90° to the piston pin hole.

Calculate the piston-to-cylinder clearance.

SERVICE LIMIT: 80.90 mm (3.185 in)

Refer to page 7-3 for cylinder bore inspection.

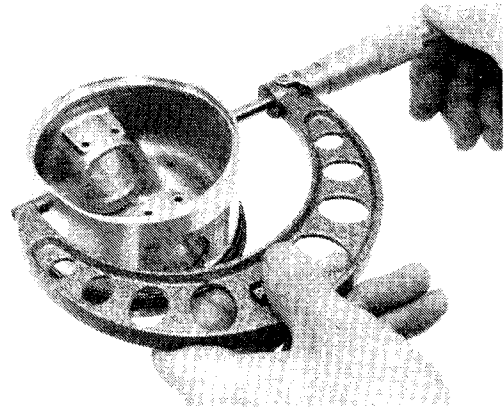

Measure the piston pin hole I.D.

SERVICE LIMIT: 21.04 mm (0.828 in)

Measure the O.D. of the piston pin.

SERVICE LIMIT: 20.96 mm (0.825 in)

Calculate the piston-to-piston pin clearance.

SERVICE LIMIT: 0.02 mm (0.001 in)

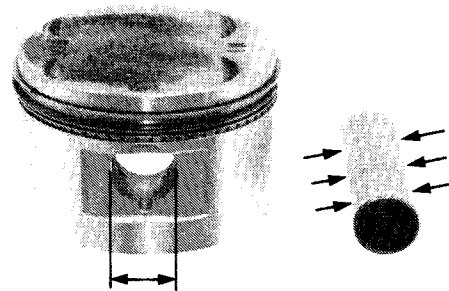

Measure the connecting rod small end I.D.

SERVICE LIMIT: 21.10 mm (0.831 in)



PISTON INSTALLATION

Clean the piston ring grooves thoroughly and install the piston rings.

NOTE

- Avoid piston and piston ring damage during installation.
- Install the piston rings with the marking (T or R) facing up.
- Do not mix the top and second rings.

Space the piston ring end gaps 120 degrees apart. Do not align the gaps in the oil rings (side rails).

After installation, the rings should be free to rotate in the ring grooves.

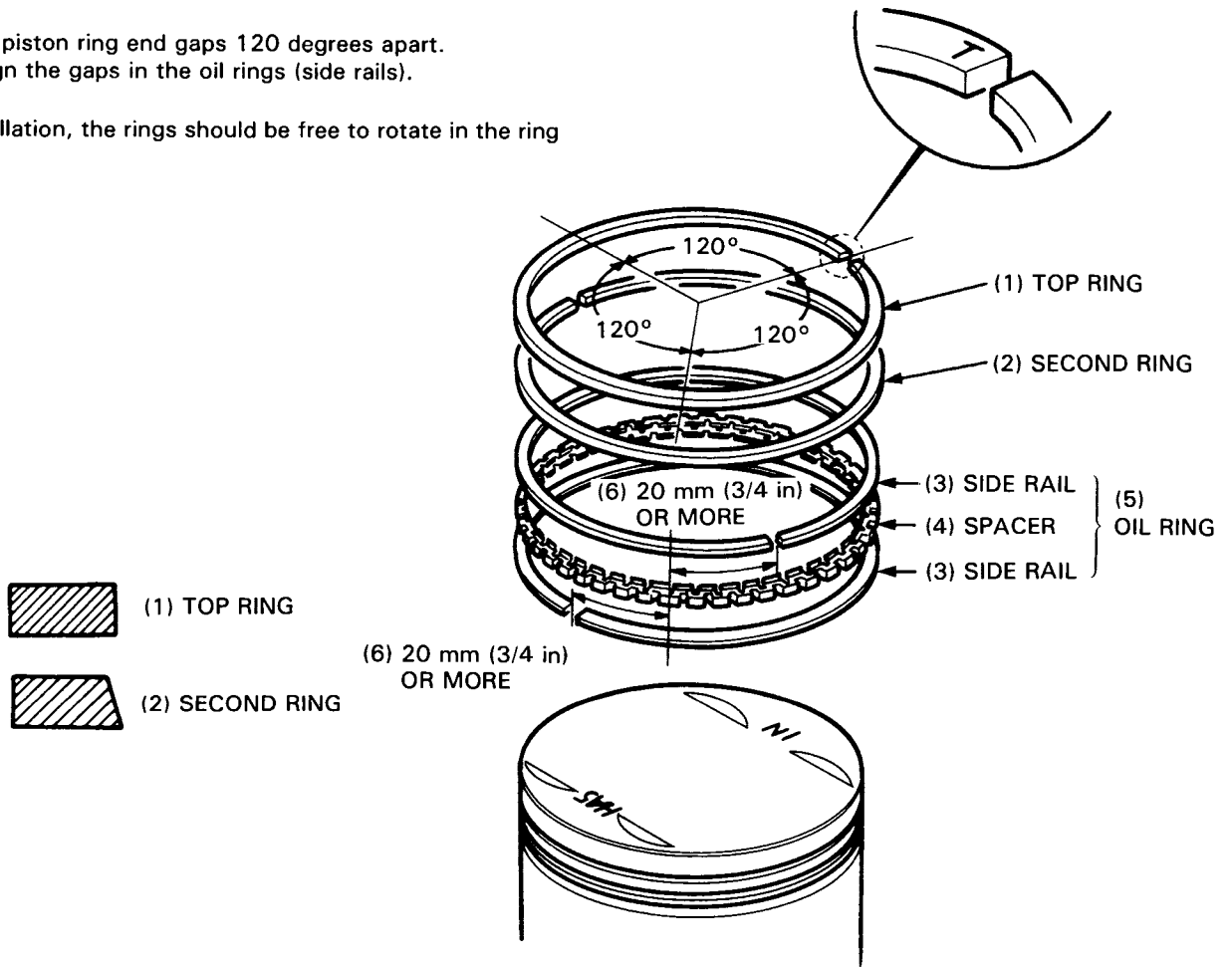

Install the piston and piston pin, using new piston pin clips.

NOTE

- Position the piston "IN" mark on the intake valve side.
- Do not align the piston pin clip end gap with the piston cut-out.
- Do not let the clip fall into the crankcase.

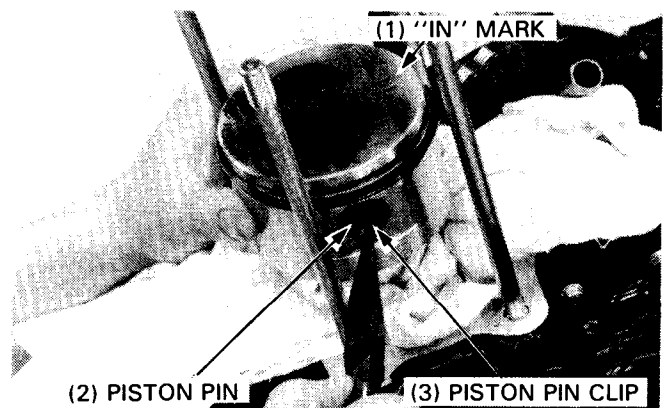

CYLINDER INSTALLATION

Clean off any gasket material from the crankcase surface.

NOTE

- Be careful not to damage the gasket surface.

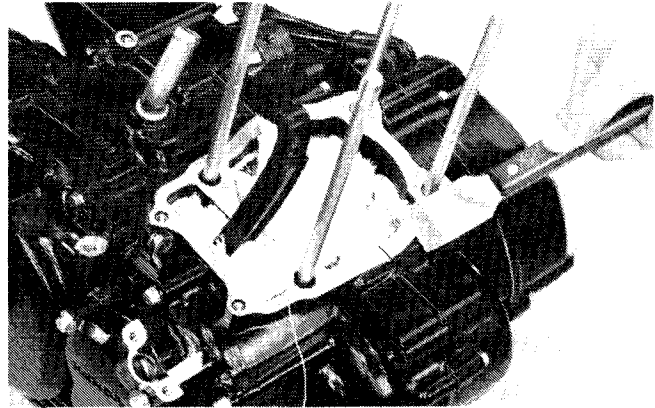

Install a new gasket and dowel pins.

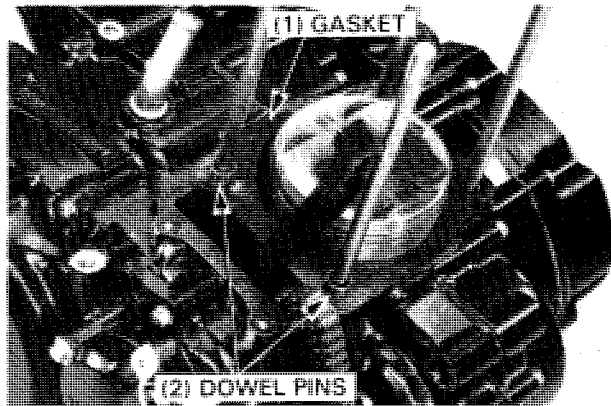

Coat the cylinder bore and piston rings with engine oil and install the cylinder.

NOTE

- Avoid piston ring damage during installation.
- Do not let the cam chain fall into the crankcase.

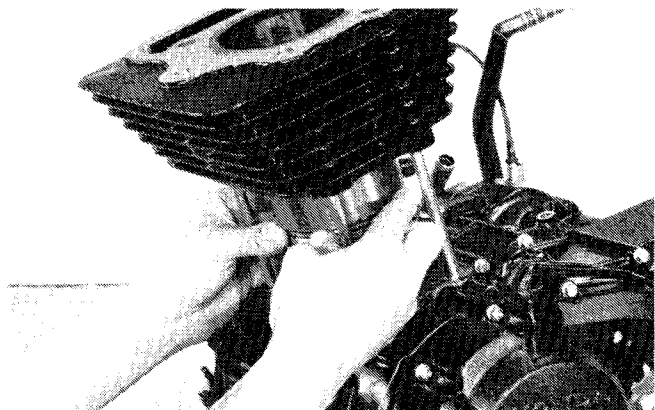

Tighten the cylinder mount bolts.

TORQUE: 8–12 N·m (0.8–1.2 kg·m, 6–9 ft·lb)

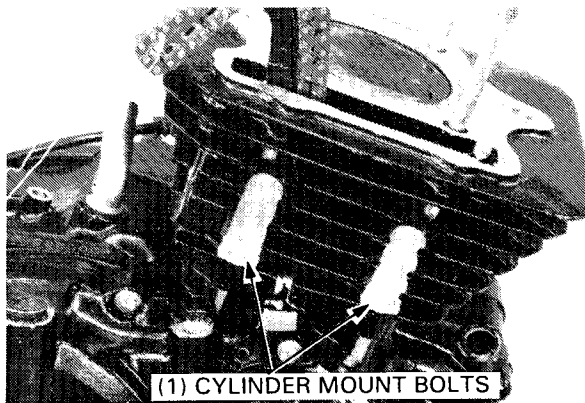

Install the cam chain tensioner guide, aligning its lower end with the groove in the crankcase and its bosses with the grooves in the cylinder upper surface.

Install the gasket and dowel pins.

Install the cylinder head (Section 6).

Install the engine in the frame (Section 5).

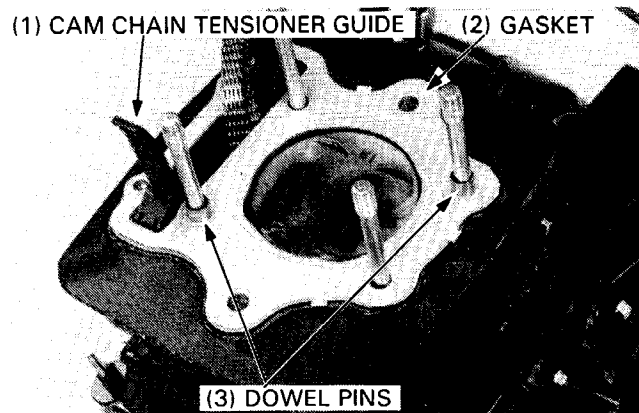

CLUTCH/OIL PUMP/KICK STARTER

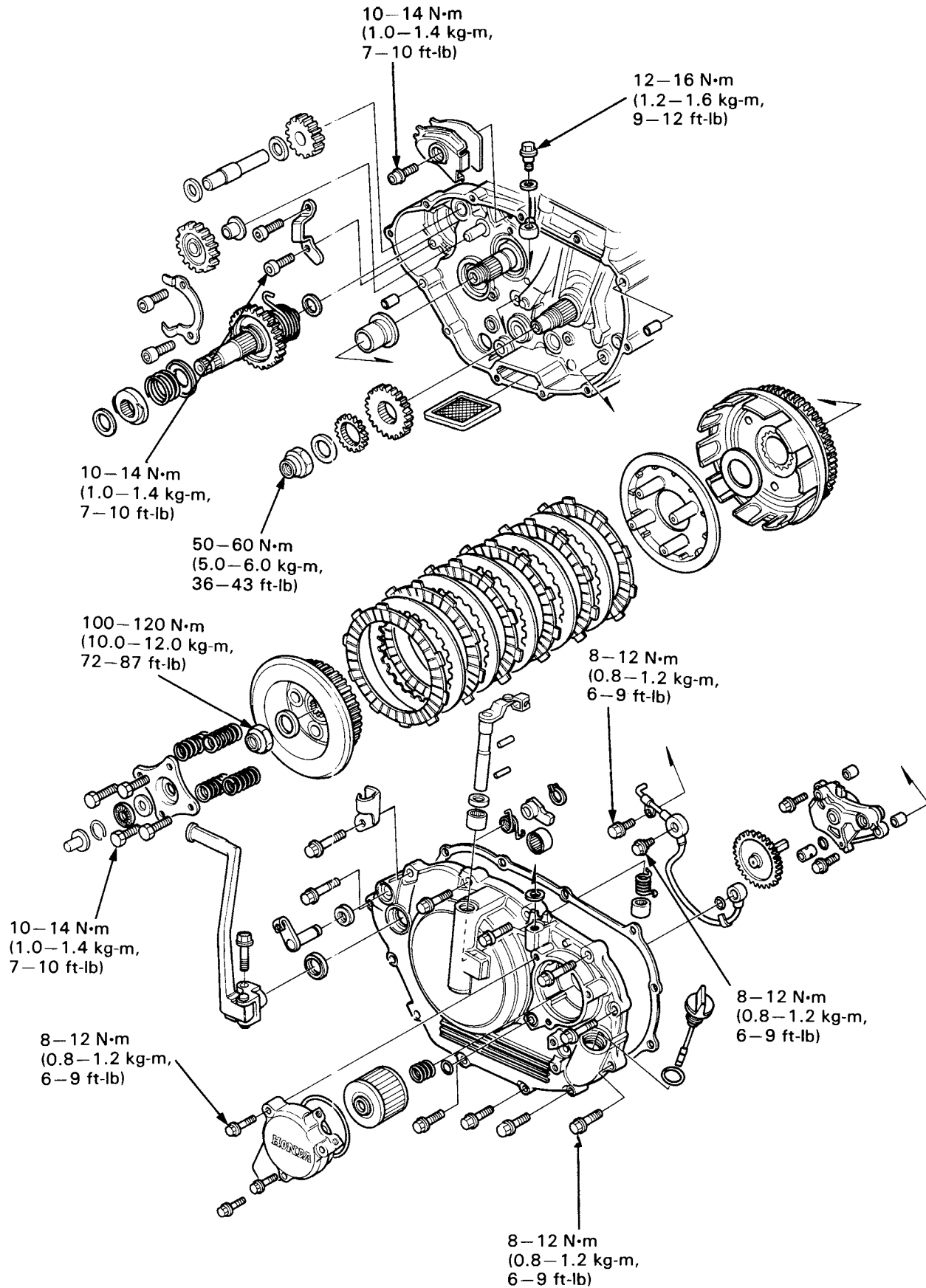

8. CLUTCH/OIL PUMP/KICK STARTER

SERVICE INFORMATION	8-1	OIL PUMP	8-10
TROUBLESHOOTING	8-2	PRIMARY DRIVE GEAR	8-13
RIGHT CRANKCASE COVER REMOVAL	8-3	KICK STARTER	8-14
OIL FILTER SCREEN CLEANING	8-6	RIGHT CRANKCASE COVER	
CLUTCH	8-6	INSTALLATION	8-19

SERVICE INFORMATION

GENERAL

- This section covers removal and installation of the right crankcase cover, clutch, oil pump, primary drive gear and kick starter. These services can be performed with the engine in the frame.

SPECIFICATIONS

ITEM		STANDARD	SERVECE LIMIT
Clutch	Spring free length	37.2 mm (1.46 in)	36.2 mm (1.43 in)
	Disc thickness	2.92–3.08 mm (0.115–0.121 in)	2.6 mm (0.10 in)
	Disc warp	—	0.20 mm (0.008 in)
	Plate warp	—	0.20 mm (0.008 in)
	Clutch outer I.D.	28.000–28.021 mm (1.1024–1.1032 in)	28.05 mm (1.104 in)
	Clutch outer guide O.D.	27.959–27.980 mm (1.1007–1.1016 in)	27.92 mm (1.099 in)
Oil pump	Pump end clearance	0.02–0.08 mm (0.001–0.003 in)	0.10 mm (0.004 in)
	Rotor tip clearance	0.15 mm (0.006 in)	0.20 mm (0.008 in)
	Rotor-to-body clearance	0.15–0.21 mm (0.006–0.008 in)	0.25 mm (0.010 in)
Kick starter	Shaft O.D.	21.959–21.980 mm (0.8645–0.8654 in)	21.90 mm (0.862 in)
	Pinion gear I.D.	22.020–22.041 mm (0.8669–0.8678 in)	22.10 mm (0.870 in)
	2nd idler gear I.D.	18.014–18.034 mm (0.7092–0.7100 in)	18.06 mm (0.711 in)
	2nd idler gear bushing O.D.	17.966–17.984 mm (0.7073–0.7080 in)	17.93 mm (0.706 in)
	2nd idler shaft O.D.	13.973–13.984 mm (0.5501–0.5506 in)	13.95 mm (0.549 in)
	2nd idler gear bushing I.D.	14.000–14.021 mm (0.5512–0.5520 in)	14.05 mm (0.553 in)

TORQUE VALUES

Oil bolts	8–12 N·m (0.8–1.2 kg-m, 6–9 ft-lb)
Kick ratchet guide	10–14 N·m (1.0–1.4 kg-m, 7–10 ft-lb)
Clutch lock nut	100–120 N·m (10.0–12.0 kg-m, 72–87 ft-lb)
Clutch lifter plate bolt	10–14 N·m (1.0–1.4 kg-m, 7–10 ft-lb)
Primary drive gear lock nut	50–60 N·m (5.0–6.0 kg-m, 36–43 ft-lb)

CLUTCH/OIL PUMP/KICK STARTER

TOOLS

Special

Clutch center holder	07923--KE10000] Not available in U.S.A.
Primary drive gear holder	07724--0010100	

Common

Driver	07749--0010000
Attachment, 24 x 26 mm	07746--0010700
Pilot, 20 mm	07746--0040500
Extension bar	07716--0020500 or equivalent commercially available in U.S.A.
Lock nut wrench, 17 x 27 mm	07716--0020300 or equivalent commercially available in U.S.A.
Pin driver, 3 mm	07744--0010200 or equivalent commercially available in U.S.A.
Universal holder	07724--0030000

TROUBLESHOOTING

Faulty clutch operation can usually be corrected by adjusting the clutch.

Clutch slips when accelerating

- Faulty clutch lifter.
- Discs worn.
- Weak spring.

Clutch will not disengage

- Faulty clutch lifter.
- Plates warped.

ATC creeps with clutch disengaged

- Plates warped.

Clutch operation feels rough

- Outer drum slots rough.

Hard to shift

- Incorrect clutch adjustment.
- Faulty clutch lifter.

Low oil pressure

- Faulty oil pump.
- Oil pump drive gear broken.

RIGHT CRANKCASE COVER REMOVAL

Drain the engine oil (page 2-2).
 Disconnect the clutch cable from the clutch arm.
 Remove the oil bolt with the two sealing washers.

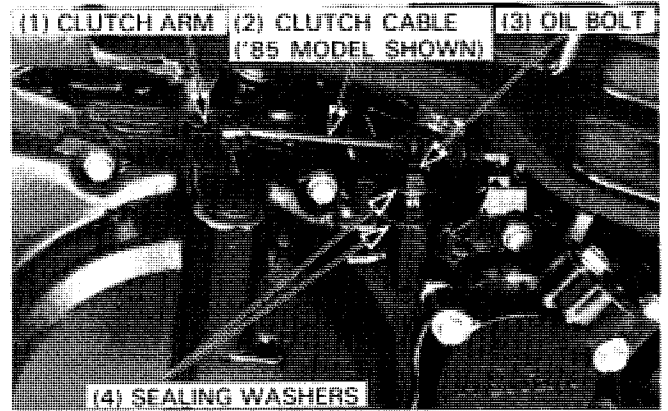

Remove the oil cooler pipe bolts and disconnect the pipes from the right crankcase cover.

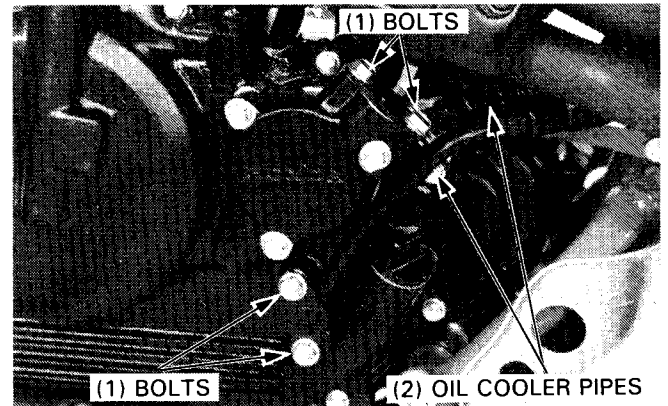

Remove the decompressor cable holder bolt and disconnect the cable from the cam follower shaft arm.

Remove the kick starter arm pinch bolt and the arm.

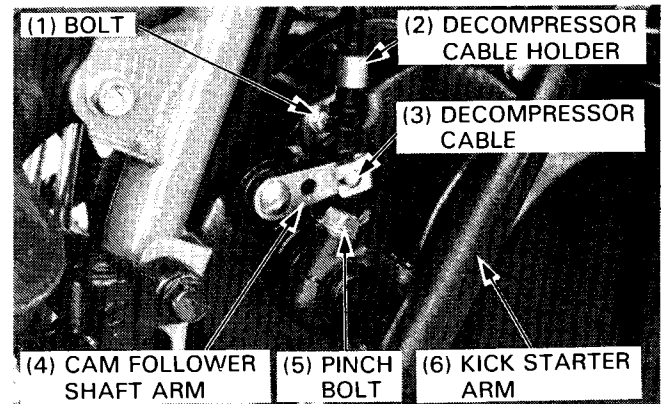

Remove the right crankcase cover bolts and the cover.

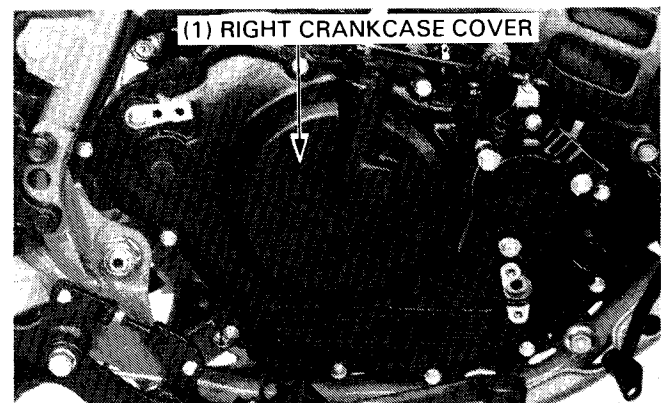

CLUTCH/OIL PUMP/KICK STARTER

Remove the gasket and dowel pins.

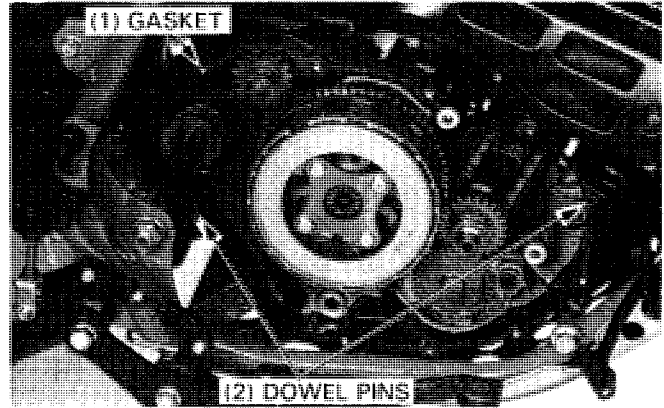

CLUTCH LIFTER REMOVAL

Remove the clutch lifter piece.

Unhook the return spring from the spring pin.

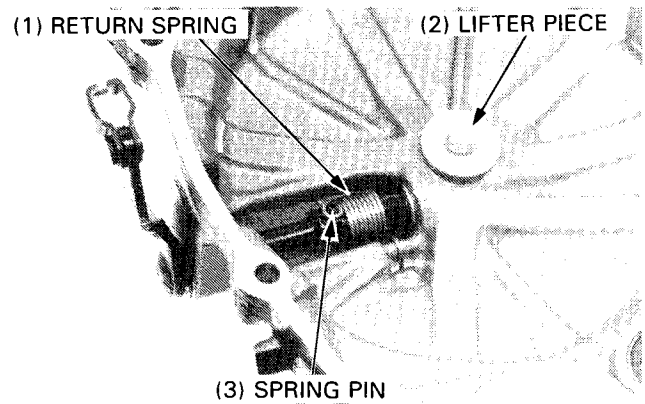

Drive in the spring pin until it is flush with the lifter shaft surface and remove the lifter arm shaft and return spring.

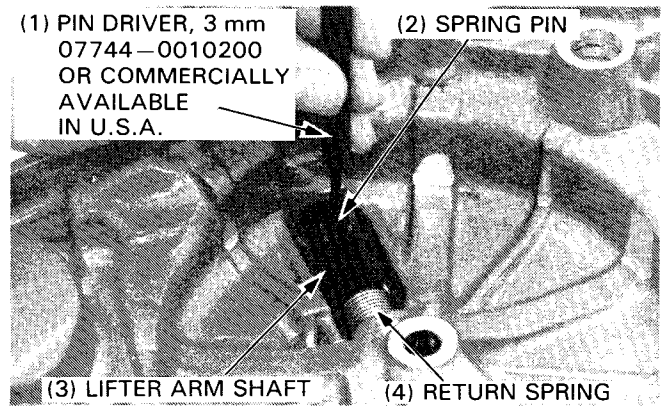

Drive out the spring pin from the lifter arm shaft and discard it.

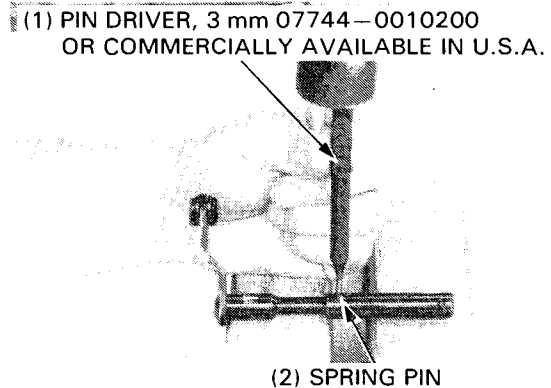

DECOMPRESSOR CAM FOLLOWER SHAFT DISASSEMBLY

Remove the snap ring, cam follower, spring and cam follower shaft.

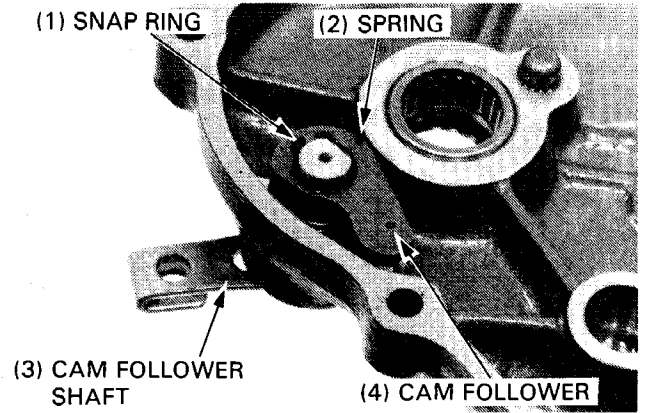

NEEDLE BEARING/OIL SEAL REPLACEMENT

Check the oil seals and needle bearings for wear or damage and replace if necessary.

Remove the snap ring and crankshaft oil seal.

Remove each oil seal and needle bearing.

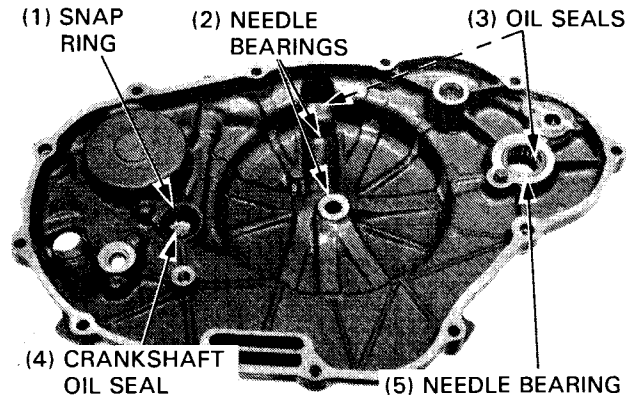

Drive in a new kick starter shaft needle bearing using the special tools.

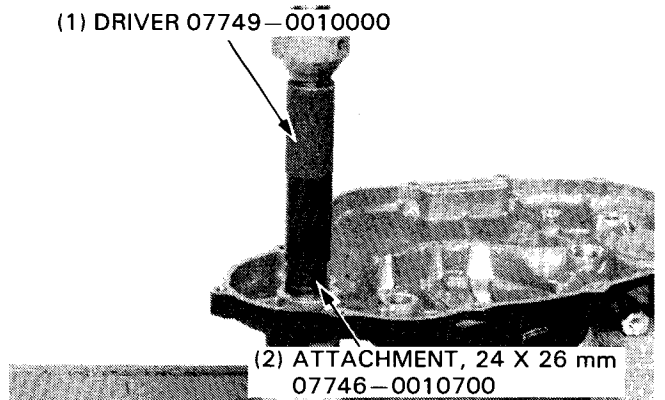

Install new kick starter and cam follower shaft oil seals.

Install new clutch lifter needle bearings and an oil seal.

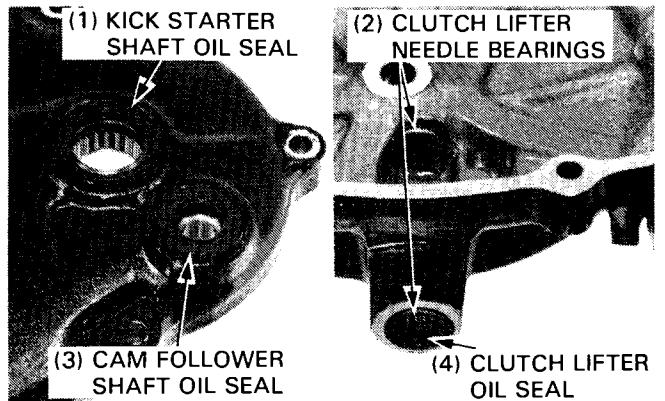

CLUTCH/OIL PUMP/KICK STARTER

Install a new crankshaft oil seal with its lip facing down.
Install the snap ring.

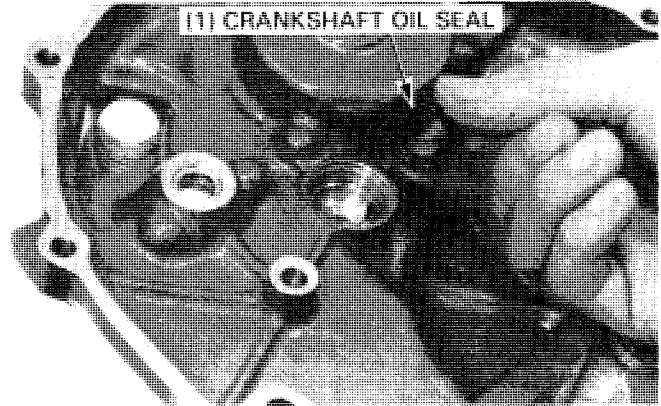

OIL FILTER SCREEN CLEANING

Remove the oil filter screen and clean it.

Install the oil filter screen with its dot mark facing up.

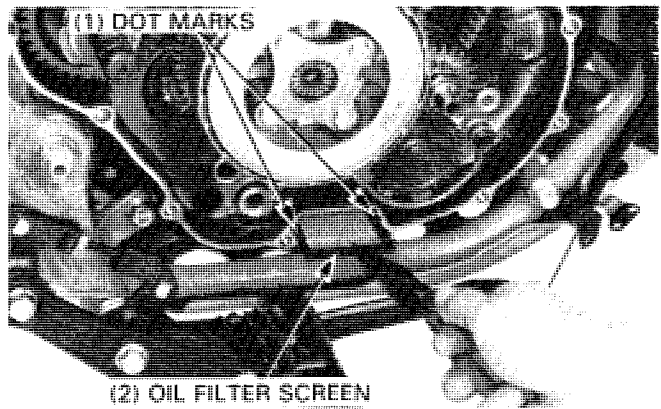

CLUTCH

REMOVAL

Remove the clutch bolts, lifter plate and springs.

NOTE

- Loosen the bolts in a crisscross pattern in 2-3 steps.

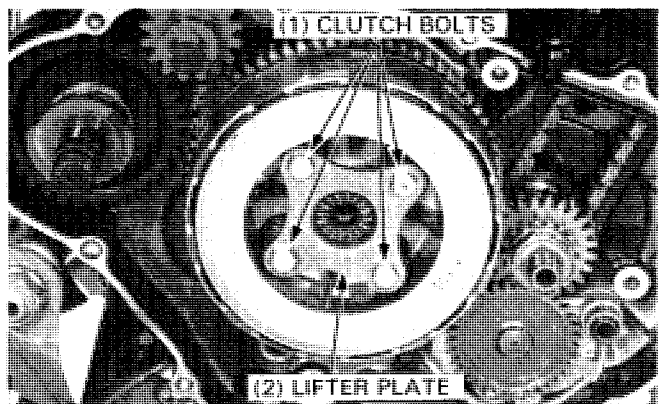

Remove the snap ring, clutch release bearing and washer from the lifter plate.

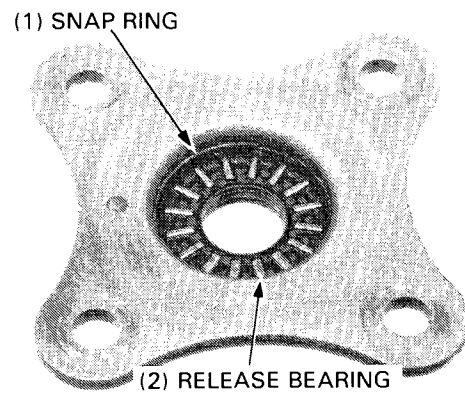

Unstake the clutch lock nut with a drill or grinder. Be careful not to damage the shaft threads.

Install the clutch center holder and remove the clutch lock nut.

TOOLS:

- (1) CLUTCH CENTER HOLDER 07923-KE10000 Not available in U.S.A.
- (2) LOCK NUT WRENCH, 17 x 27 mm 07716-0020300 or equivalent commercially available in U.S.A.
- (3) EXTENSION BAR 07716-0020500 or equivalent commercially available in U.S.A.

NOTE

- If the CLUTCH CENTER HOLDER, 07923-KE10000 is not available, shift the transmission into gear and use the UNIVERSAL HOLDER, 07725-0030000 to hold the drive sprocket.

Remove the washer, clutch center, plates, discs and pressure plate.

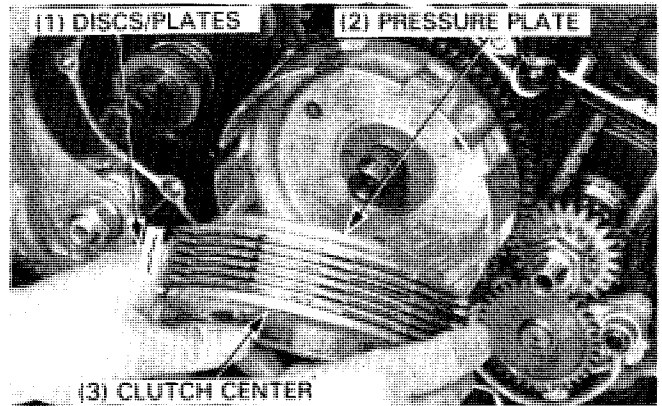
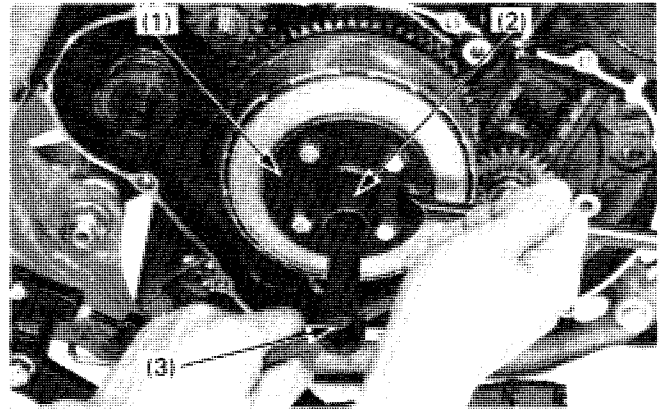

Remove the thrust washer and clutch outer.

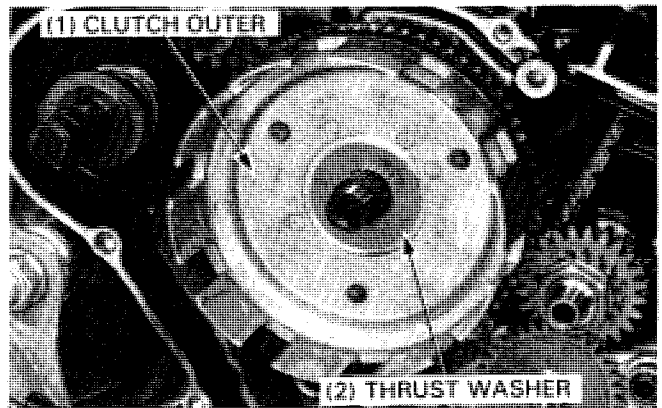

Remove the clutch outer guide from the mainshaft.

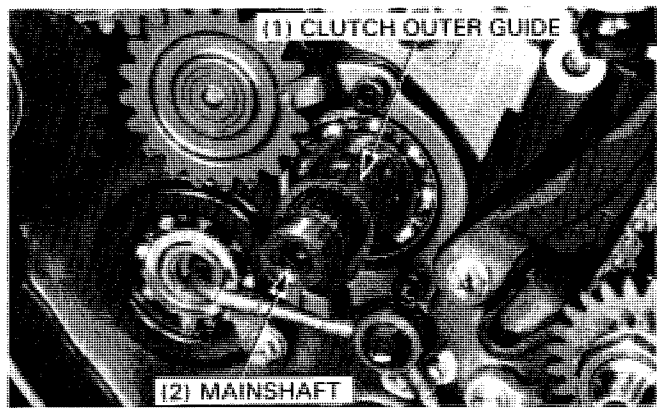

CLUTCH/OIL PUMP/KICK STARTER

INSPECTION

Check the slots of the clutch outer for damage or wear made by the clutch discs. Replace the outer if necessary.

Measure the O.D. of the clutch outer guide and I.D. of the clutch outer.

SERVICE LIMIT:

I.D. : 28.05 mm (1.104 in)

O.D.: 27.92 mm (1.099 in)

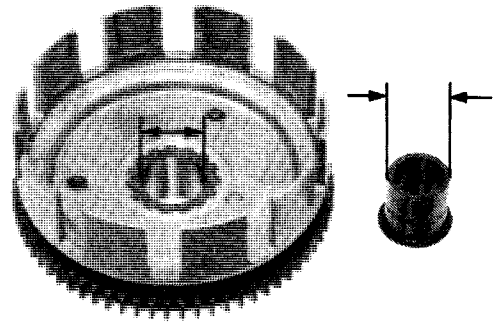

Measure the spring free length.

SERVICE LIMIT: 36.2 mm (1.43 in)

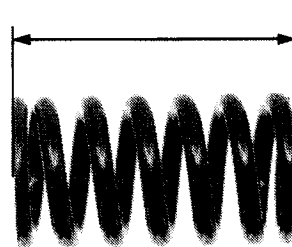

Replace the clutch discs if they show signs of scoring or discoloration.

Measure the disc thickness.

SERVICE LIMIT: 2.6 mm (0.10 in)

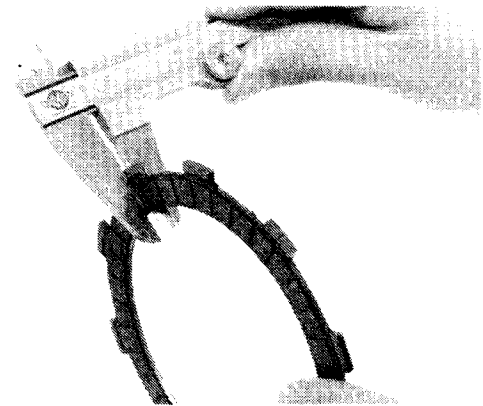

Check for plate and disc warpage on a surface plate using a feeler gauge.

SERVICE LIMIT: 0.20 mm (0.008 in)

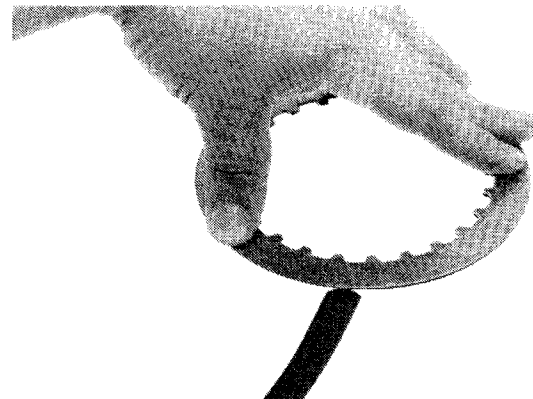

INSTALLATION

Install the clutch outer guide, clutch outer and thrust washer.

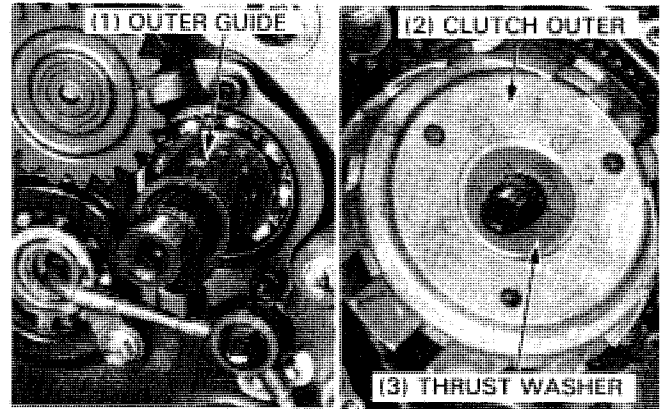

Assemble the pressure plate, discs, plates and clutch center.

NOTE

- Stack the discs and plates alternately.
- Coat new discs with engine oil.

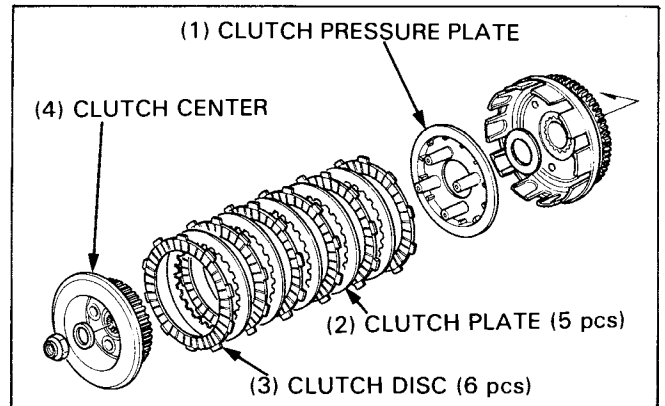

Install the washer and a new lock nut.

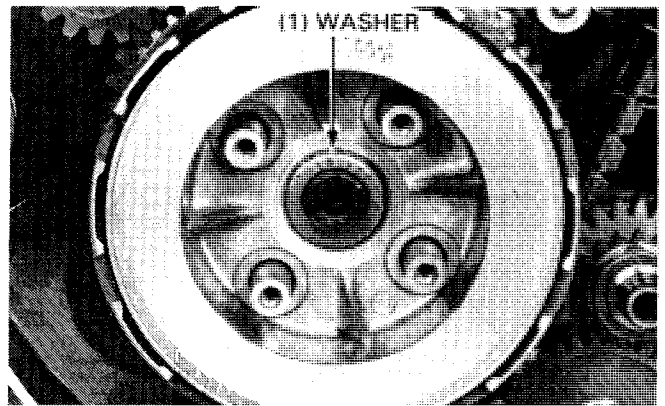

Tighten the lock nut.

TORQUE: 100 – 120 N·m (10.0 – 12.0 kg·m, 72 – 87 ft·lb)

TOOLS:

- (1) CLUTCH CENTER HOLDER 07923–KE10000 Not available in U.S.A.
- (2) LOCK NUT WRENCH, 17 x 27 mm 07716–0020300 or equivalent commercially available in U.S.A.
- (3) EXTENSION BAR 07716–0020500 or equivalent commercially available in U.S.A.

NOTE

- If the CLUTCH CENTER HOLDER, 07923–KE10000 is not available, shift the transmission into gear and use the UNIVERSAL HOLDER, 07725–0030000 to hold the drive sprocket.

Stake the lock nut using a center punch.

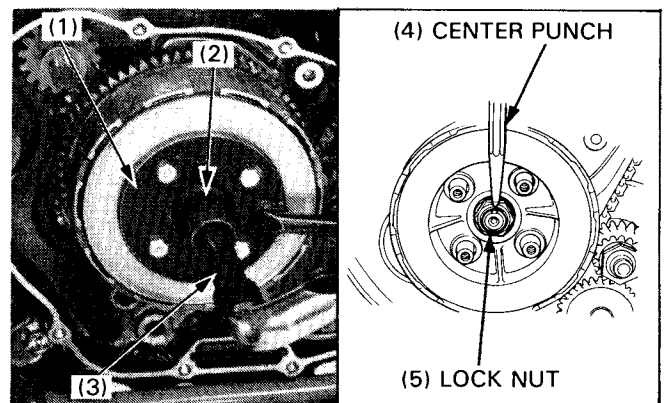

CLUTCH/OIL PUMP/KICK STARTER

Install the washer, release bearing and snap ring onto the clutch lifter plate.

Install the clutch springs, lifter plate and clutch bolts. Tighten the bolts in a crisscross pattern in 2-3 steps.

TORQUE: 10–14 N·m (1.0–1.4 kg-m, 7–10 ft-lb)

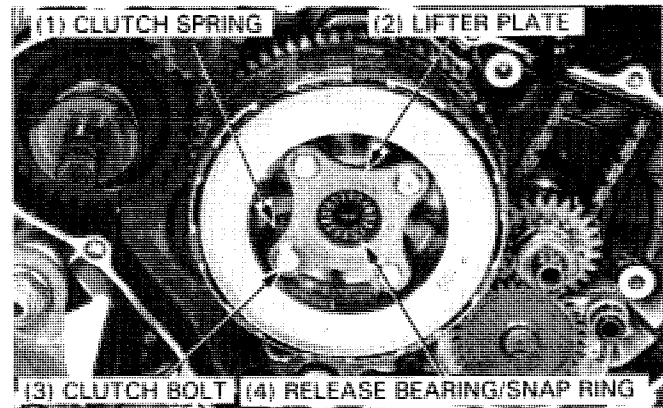

OIL PUMP

REMOVAL

Remove the clutch (page 8-6).
Remove the O-ring, oil bolt, oil pipe mount bolt and oil pipe.

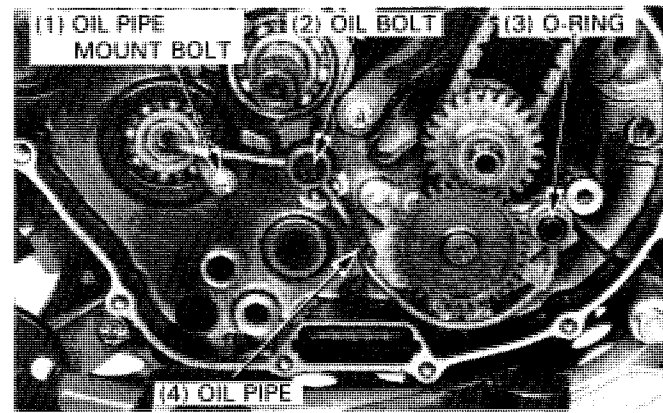

Remove the dowel pin and O-ring.
Remove the oil pump mount bolts and the pump.

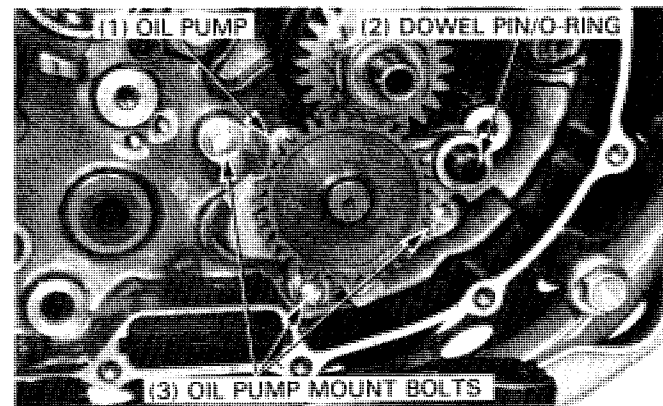

Remove the dowel pins and O-ring from the crankcase.

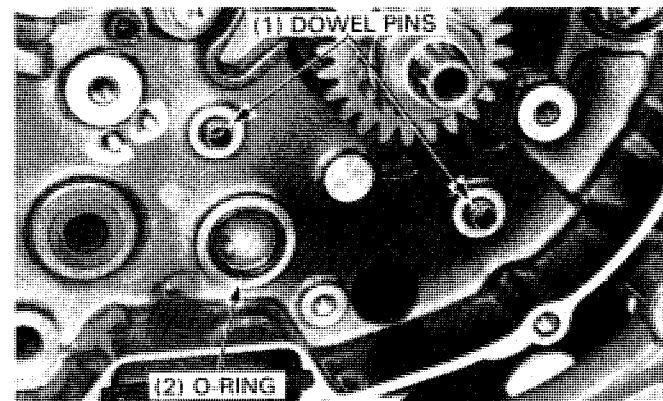

DISASSEMBLY

Remove the three screws and disassemble the oil pump.

(1) SCREWS

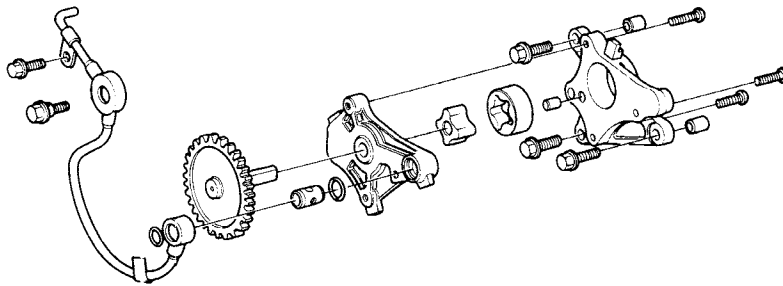
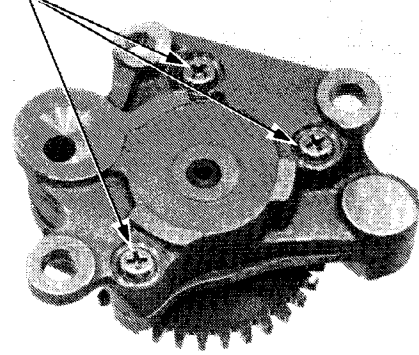

INSPECTION

Install the outer and inner rotors into the oil pump body and insert the oil pump driven gear shaft.

Measure the pump body-to-rotor clearance.

SERVICE LIMIT: 0.25 mm (0.010 in)

(1) OUTER ROTOR

(2) INNER ROTOR

(3) DRIVEN GEAR SHAFT

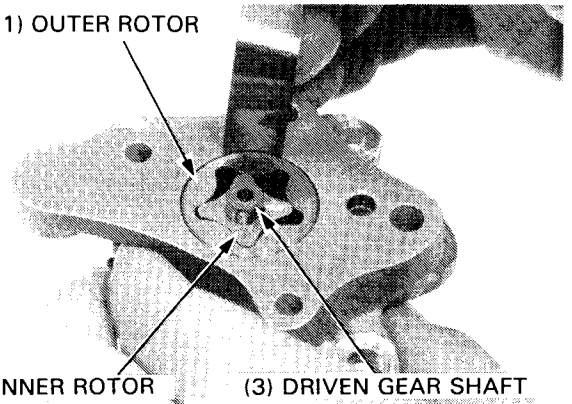

Measure the pump rotor tip clearance.

SERVICE LIMIT: 0.20 mm (0.008 in)

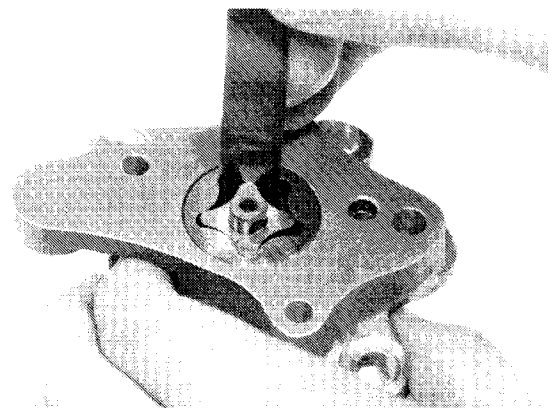

CLUTCH/OIL PUMP/KICK STARTER

Remove the oil pump driven gear shaft.

Measure the pump end clearance.

SERVICE LIMIT: 0.10 mm (0.004 in)

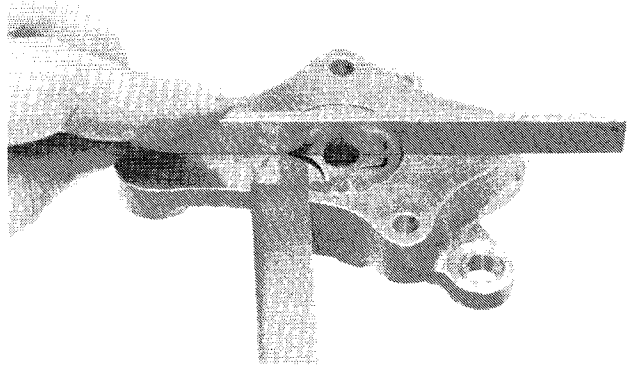

ASSEMBLY

Install the outer and inner rotors into the pump body.

Insert the driven gear shaft into the pump cover and install the dowel pin.

Align the flats on the inner rotor and gear shaft, then install the cover on the body with the dowel pins in the hole.

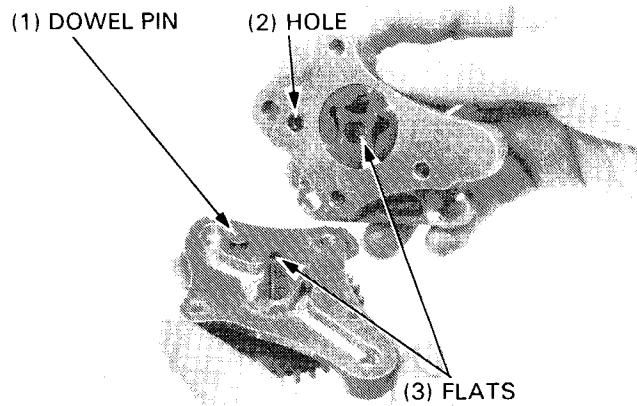

Tighten the three screws.

Make sure that the driven gear rotates freely.

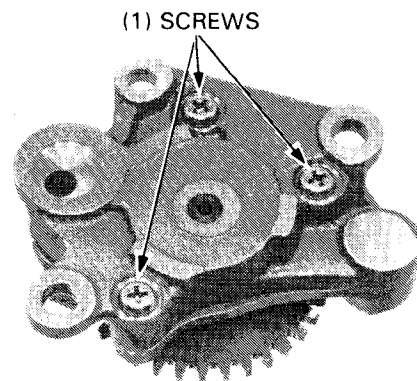

INSTALLATION

Install a new O-ring and the dowel pins into the crankcase.

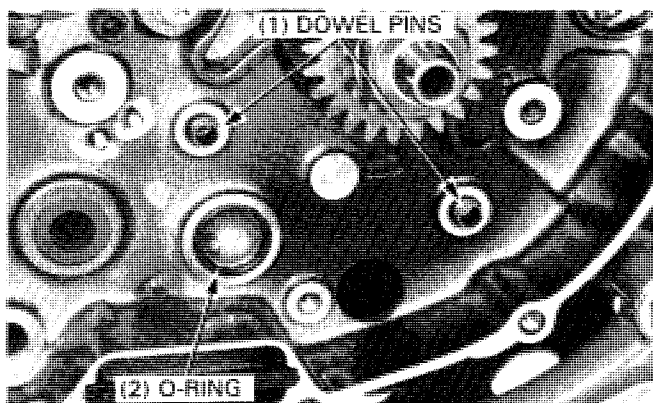

Install the oil pump and tighten the three mount bolts.

Make sure the pump drive and driven gears engage properly. Install the dowel pin and a new O-ring onto the pump.

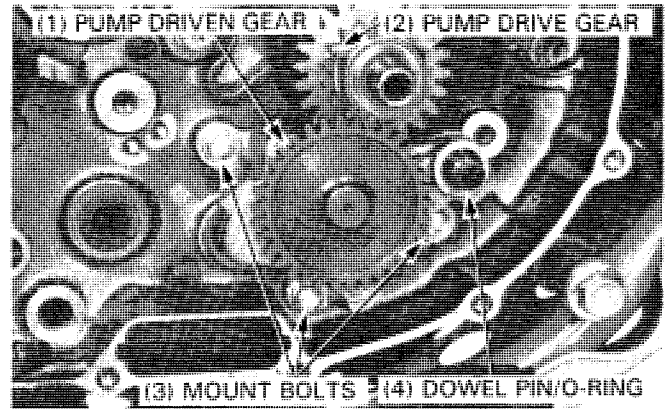

Make sure that the oil pipe is clean and install it using the mount bolt and oil bolt.

Install a new O-ring.

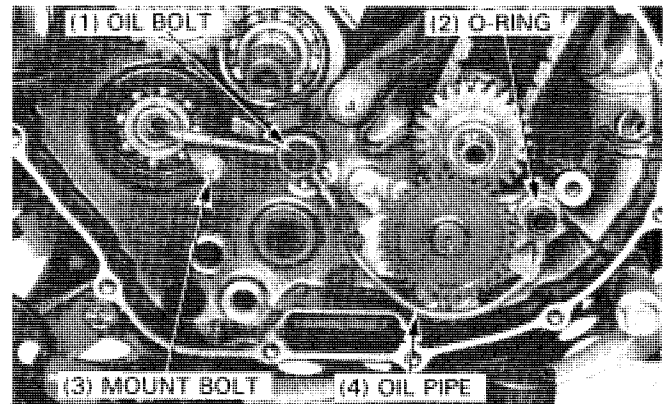

PRIMARY DRIVE GEAR

REMOVAL

NOTE

- If the GEAR HOLDER, 07724-0010100 is not available, shift the transmission into gear and hold the drive sprocket with UNIVERSAL HOLDER, 07725-0030000, and loosen the lock nut before remove the clutch assembly.

Remove the clutch (page 8-6) and the oil pump (page 8-10).

Unstake the lock nut with a drill or grinder. Be careful not to damage the shaft threads.

Temporarily install the clutch outer guide and clutch outer over the mainshaft.

Install the primary gear holder between the primary drive and driven gears as shown.

Remove the lock nut, washer, oil pump drive gear and primary drive gear from the crankshaft.

NOTE

- The lock nut has left-hand threads.

INSTALLATION

Install the primary and oil pump drive gears onto the crankshaft.

Install the lock washer with its "OUT SIDE" mark facing out.

Install a new lock nut.

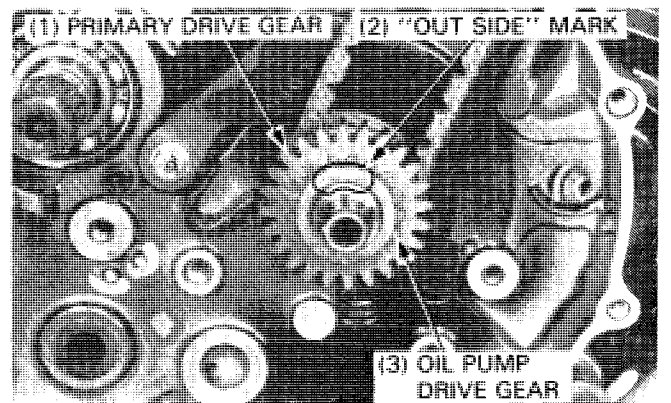
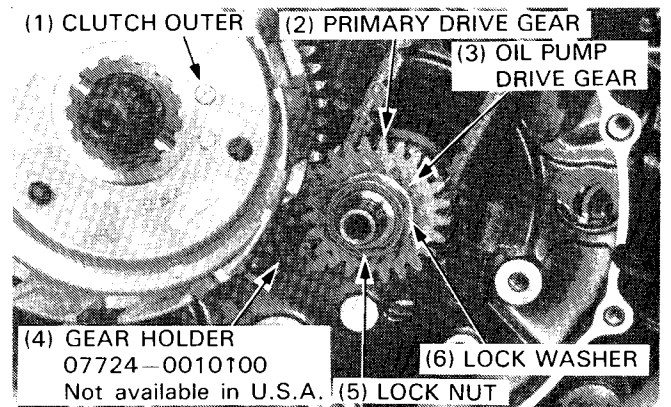

CLUTCH/OIL PUMP/KICK STARTER

Temporarily install the clutch outer guide and clutch outer.

Install the primary drive gear holder between the primary drive and driven gears.

Tighten the lock nut.

TORQUE: 50 – 60 N·m (5.0 – 6.0 kg-m, 36 – 43 ft-lb)

NOTE

- The lock nut has left-hand threads.

TOOLS:

- (2) GEAR HOLDER 07724–0010100
- (3) LOCK NUT WRENCH, 17 x 27 mm 07716–0020300 AND EXTENSION BAR 07716–0020500 or commercially available in U.S.A.

Stake the lock nut using a center punch.

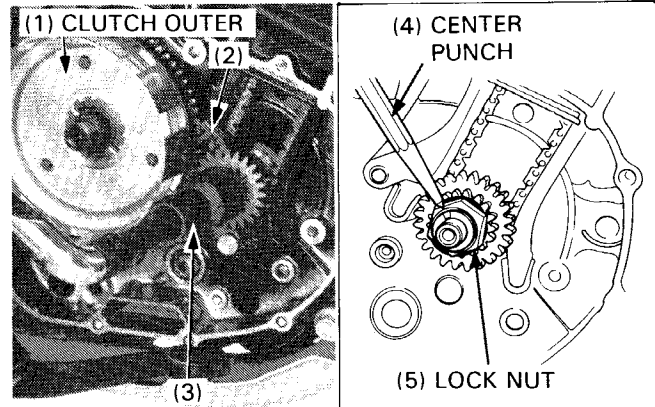

KICK STARTER

REMOVAL

Remove the clutch (page 8-6).

Remove the kick starter 1st idler shaft, thrust washers, and 1st idler gear.

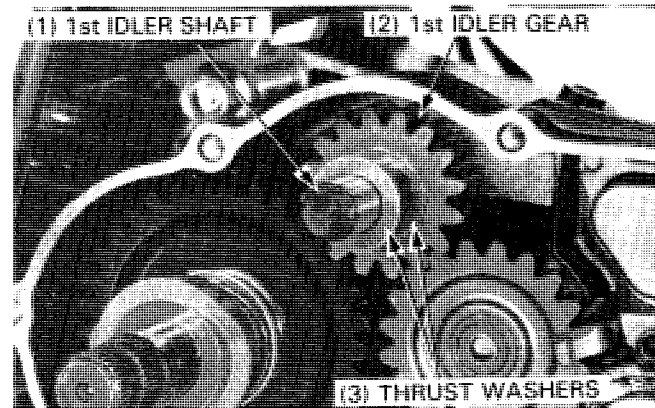

Remove the socket bolts, bearing stop plate, 2nd idler gear and bushing.

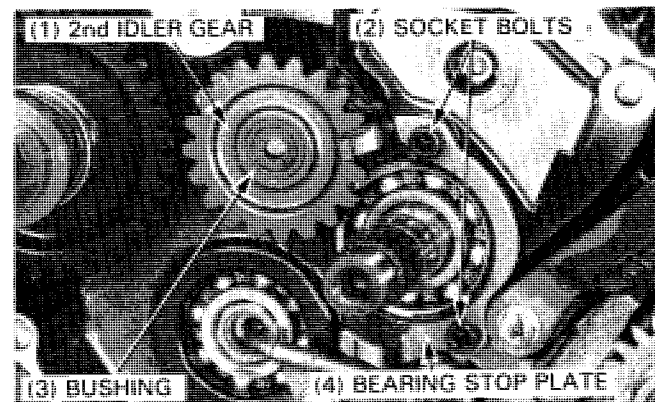

Temporarily install the kick starter arm on the kick starter shaft and remove the shaft assembly by turning the arm clockwise to free the ratchet from the ratchet guide.

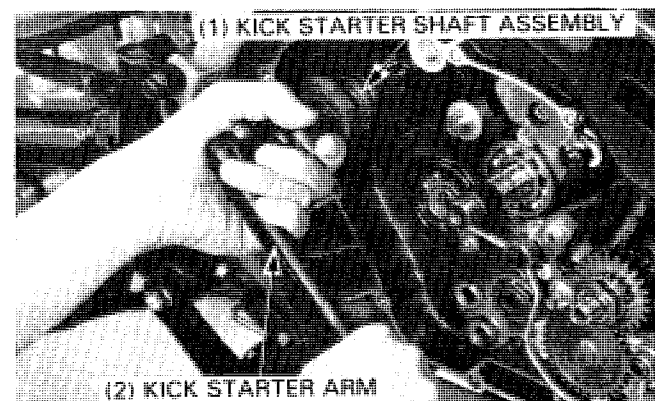

DISASSEMBLY

Remove the thrust washer, decompressor cam, spring and spring seat from the kick starter shaft.

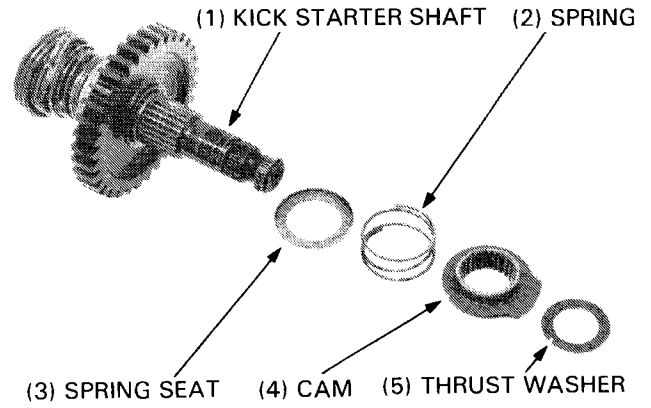

Remove the thrust washer, collar, return spring, spring seat, ratchet spring and ratchet.

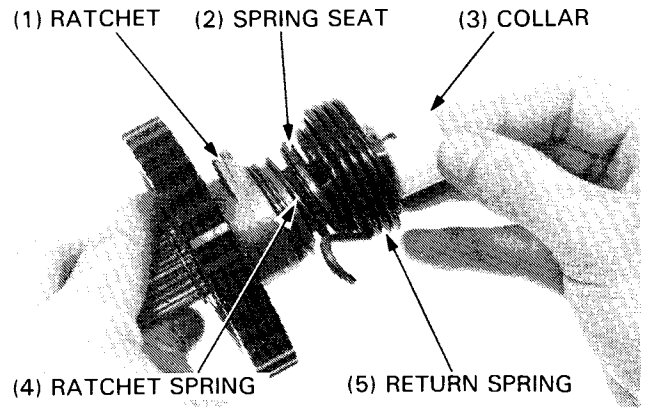

Remove the snap rings, thrust washers and starter pinion gear from the starter shaft.

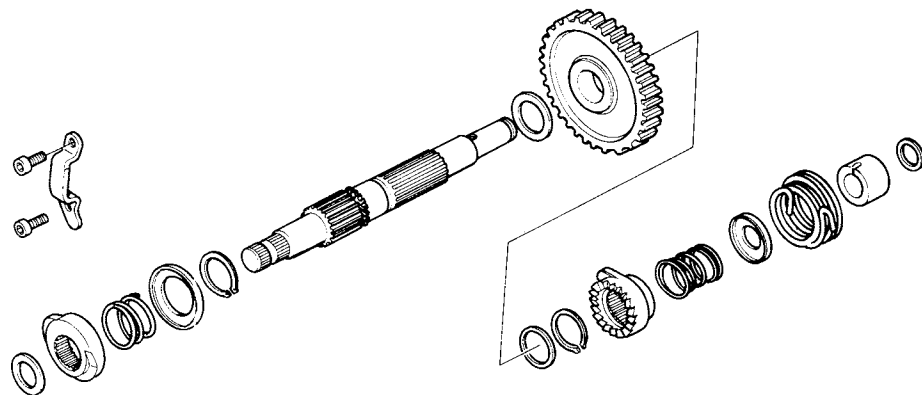
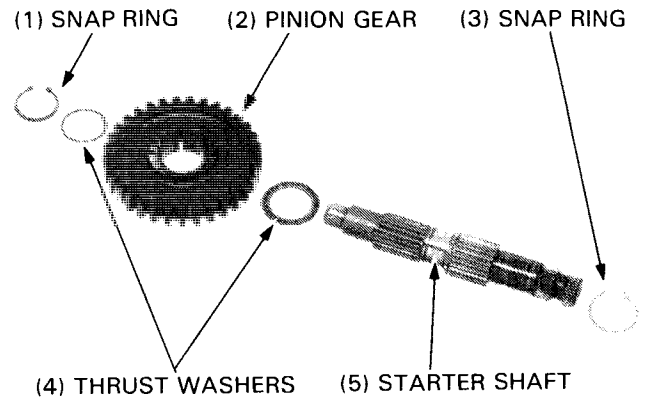

CLUTCH/OIL PUMP/KICK STARTER

INSPECTION

Measure the kick starter shaft O.D.

SERVICE LIMIT: 21.90 mm (0.862 in)

Check the pinion gear teeth for damage and measure the gear I.D.

SERVICE LIMIT: 22.10 mm (0.870 in)

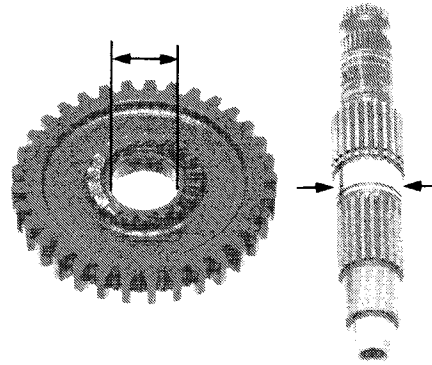

Measure the kick starter 2nd idler gear I.D.

SERVICE LIMIT: 18.06 mm (0.711 in)

Measure the 2nd idler gear bushing I.D. and O.D.

SERVICE LIMIT:

I.D. : 14.05 mm (0.553 in)

O.D.: 17.93 mm (0.706 in)

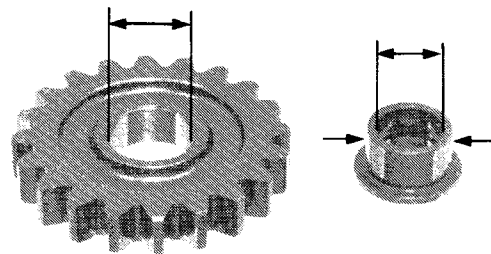

Check the kick starter shaft and kick 1st idler shaft holes in the right crankcase for wear or damage.

Measure the 2nd idler gear shaft O.D.

SERVICE LIMIT: 14.95 mm (0.589 in)

To replace the 2nd idler gear shaft, the crankcase must be separated (section 10).

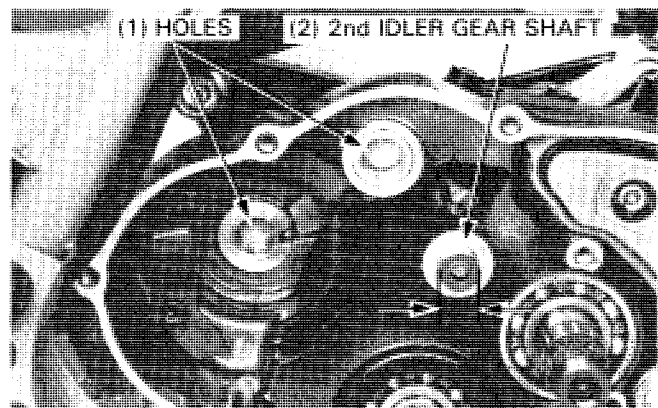

ASSEMBLY

Install the snap ring in the groove in the shaft.

Install the thrust washer, pinion gear, thrust washer and snap ring onto the shaft.

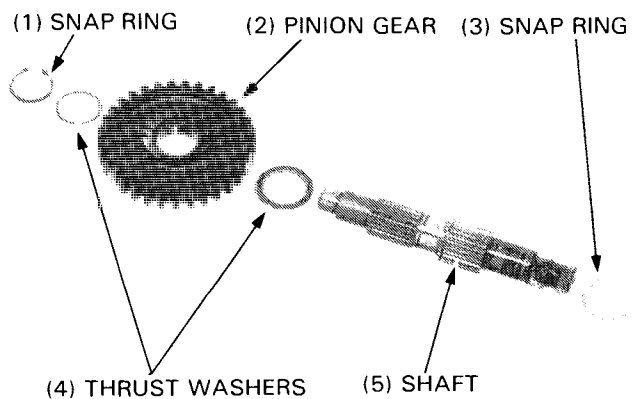

Align the punch marks and install the ratchet over the shaft.

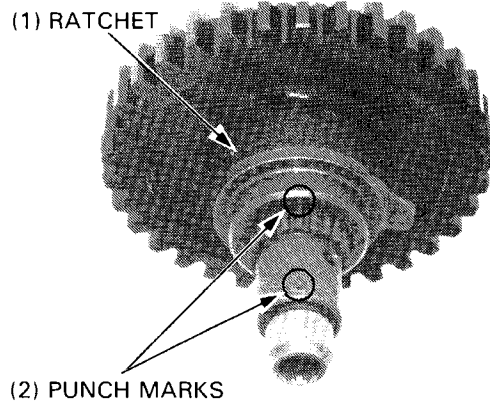

Install the ratchet spring and spring seat.

Install the return spring and insert its end into the hole in the shaft.

Install the collar, aligning its groove with the end of the return spring.

Install the thrust washer.

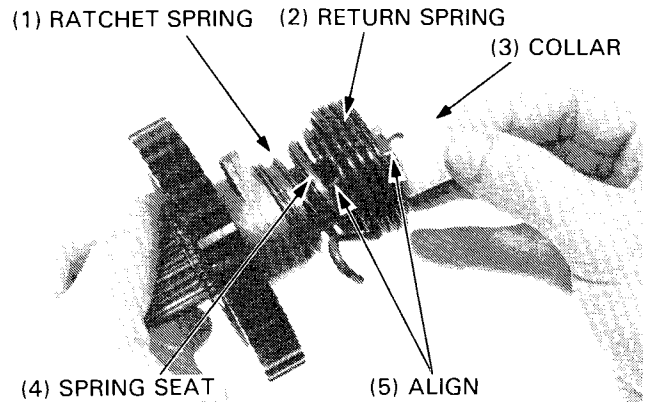

Install the spring seat and cam spring over the shaft.

Align the punch marks and install the decompressor cam.

Install the thrust washer.

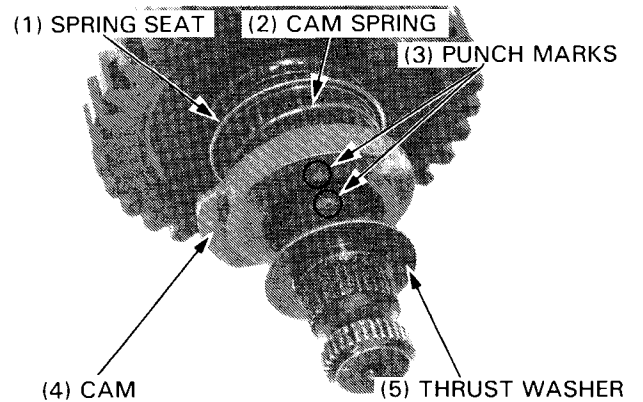

INSTALLATION

Temporarily install the kick starter arm onto the shaft.

Align the return spring hook with the crankcase boss under the ratchet guide.

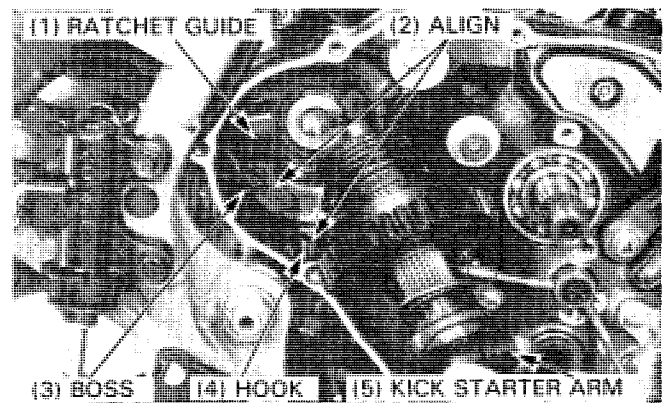

CLUTCH/OIL PUMP/KICK STARTER

Install the kick starter shaft assembly by turning it clockwise and aligning its ratchet with the ratchet guide.

Remove the kick starter arm.

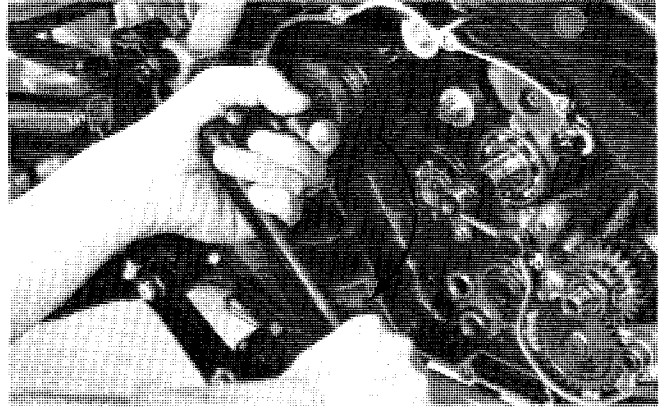

Make sure that the punch mark on the shaft faces up.

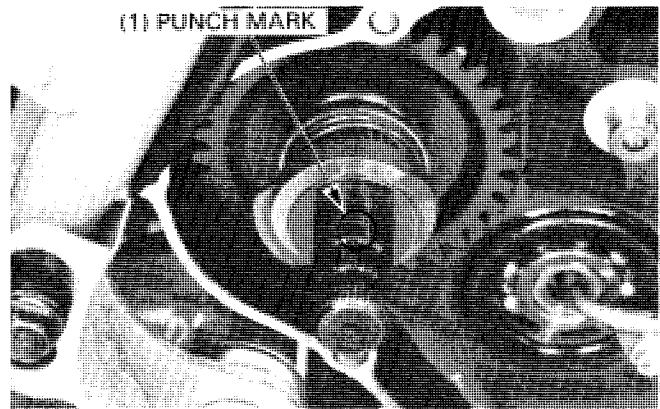

Install the 2nd idler gear bushing over the 2nd idler gear shaft with its flange facing in.

Install the idler gear.

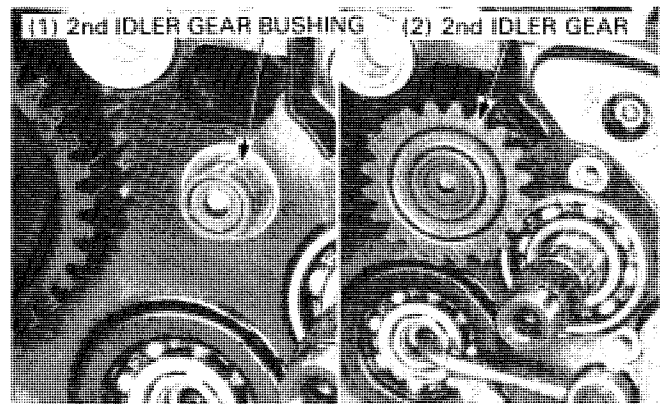

Install the bearing stop using the two socket bolts.

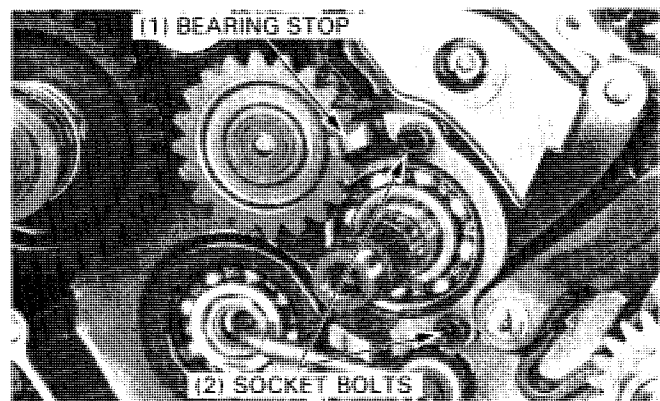

Assemble the thrust washers and kick 1st idler gear onto the kick 1st idler gear shaft and install them in the crankcase.

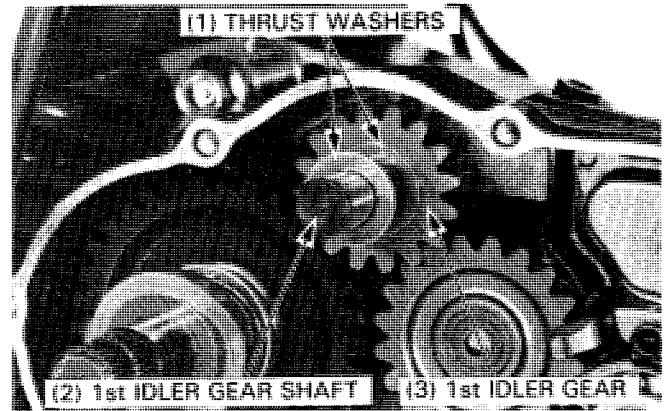

RIGHT CRANKCASE COVER INSTALLATION

DECOMPRESSOR CAM FOLLOWER SHAFT ASSEMBLY

Install the cam follower shaft and spring and insert the spring end in the hole in the cover.

Align the flats on the shaft and cam follower and install the follower.

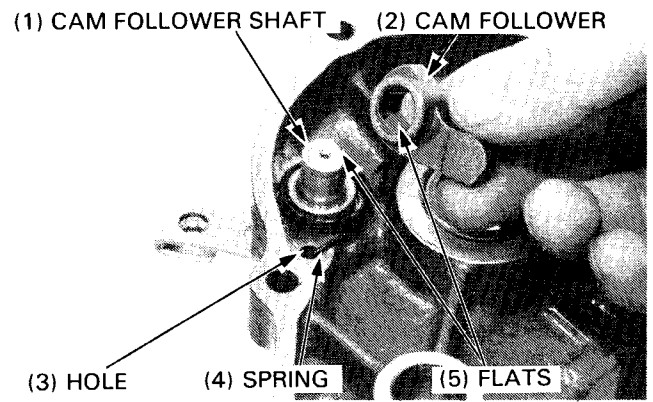

Hook the spring to the cam follower as shown.

Install the snap ring.

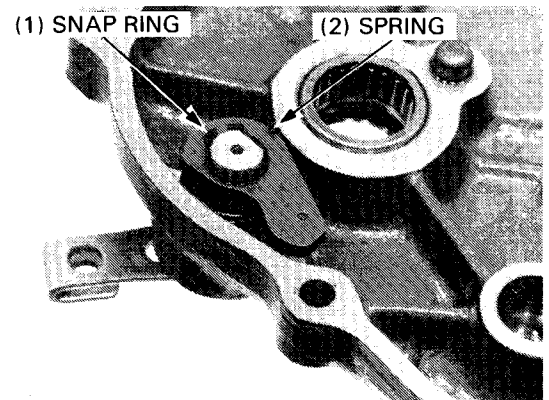

CLUTCH LIFTER INSTALLATION

Install the spring and lifter arm shaft.

Drive a new spring pin into the arm shaft hole until the pin height is 3 ± 0.5 mm (0.12 ± 0.02 in).

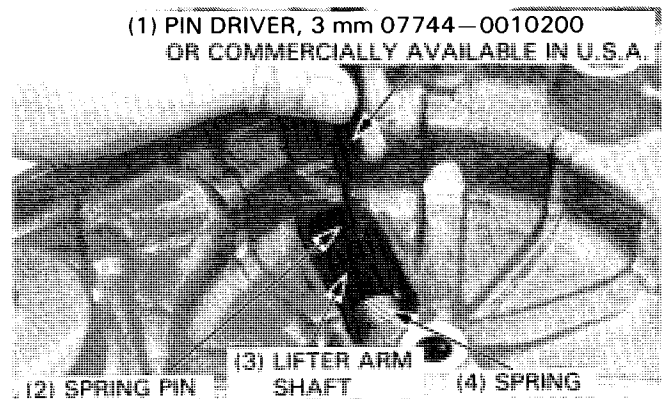

CLUTCH/OIL PUMP/KICK STARTER

Hook the end of the spring to the spring pin.

Align the cut-out in the lifter arm shaft with the lifter piece hole in the cover and install the lifter piece into the hole.

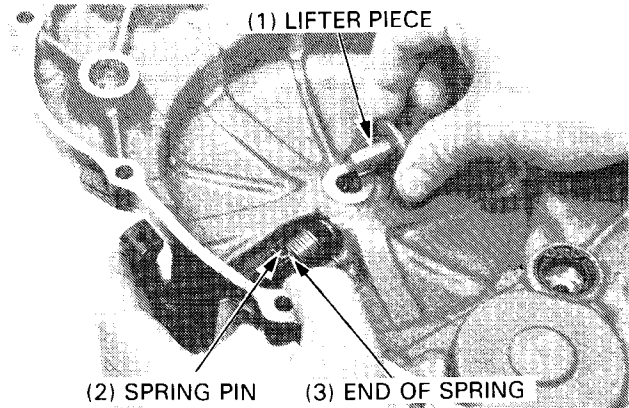

INSTALLATION

Install the dowel pins and a new gasket.

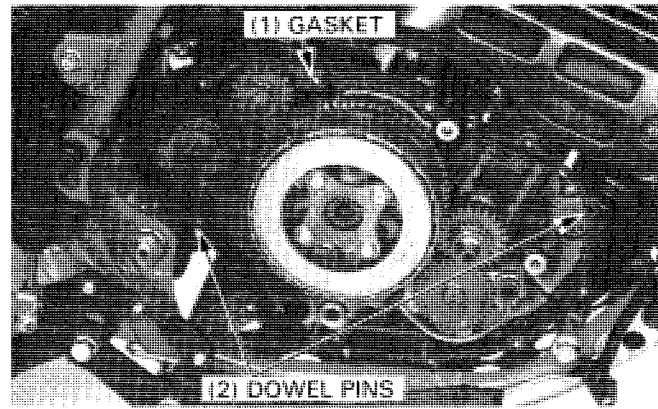

Turn the cam follower shaft arm clockwise to align the cam follower with the cam and install the right crankcase cover.

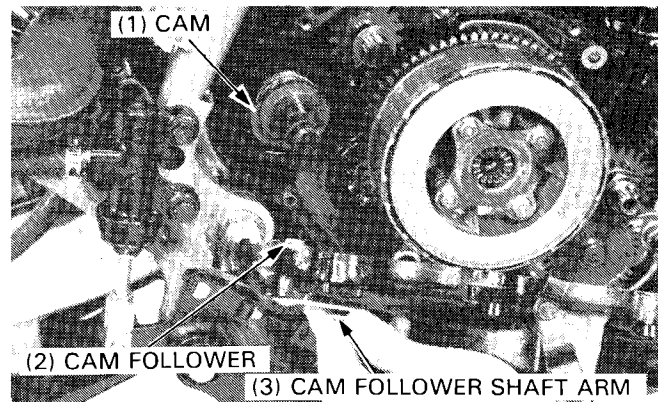

Tighten the cover bolts in a crisscross pattern in 2 or 3 steps.

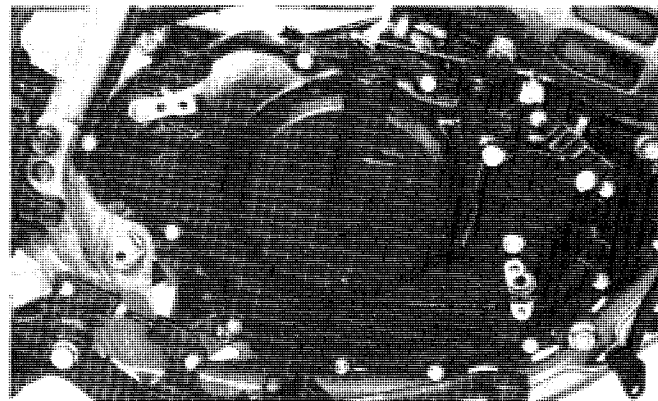

Install new O-rings onto the ends of the oil cooler pipes and connect them to the right crankcase cover using the four bolts.

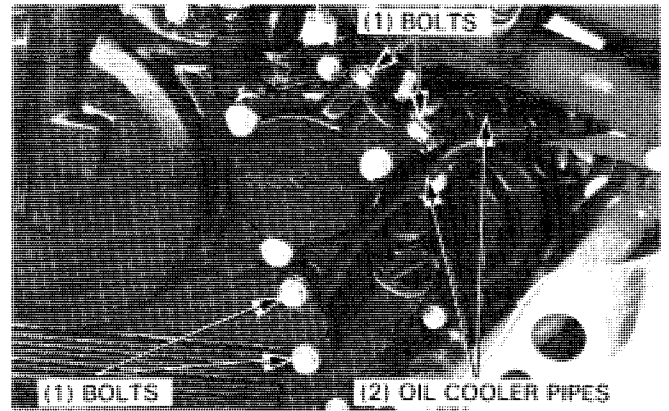

Connect the clutch cable to the clutch lifter arm.

Make sure that the sealing washers are in good condition and connect the oil pipe to the right crankcase cover using the two sealing washers and oil bolt.

TORQUE: 12–16 N·m (1.2–1.6 kg·m, 9–12 ft·lb)

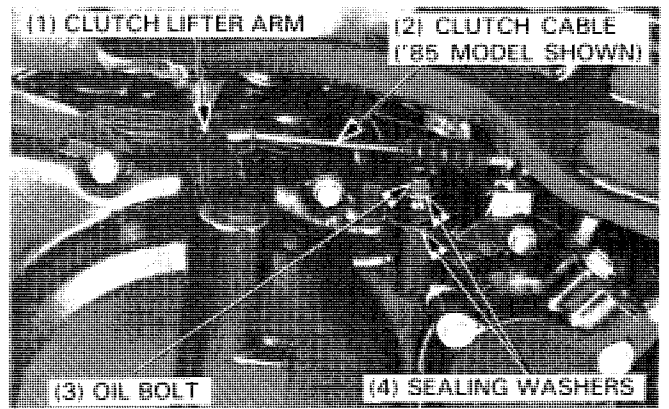

Connect the decompressor cable to the cam follower shaft arm and install the cable holder onto the right crankcase cover using the bolt.

Install the kick starter arm aligning its slit with the punch mark on the starter shaft.
Tighten the kick starter arm pinch bolt.

Fill the crankcase with the recommended oil (page 2-2).
Adjust the clutch cable (page 3-16) and the decompressor cable (page 3-6).

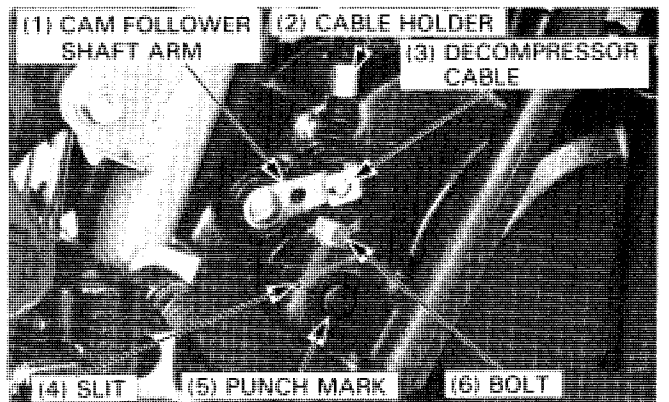

ALTERNATOR/GEARSHIFT LINKAGE

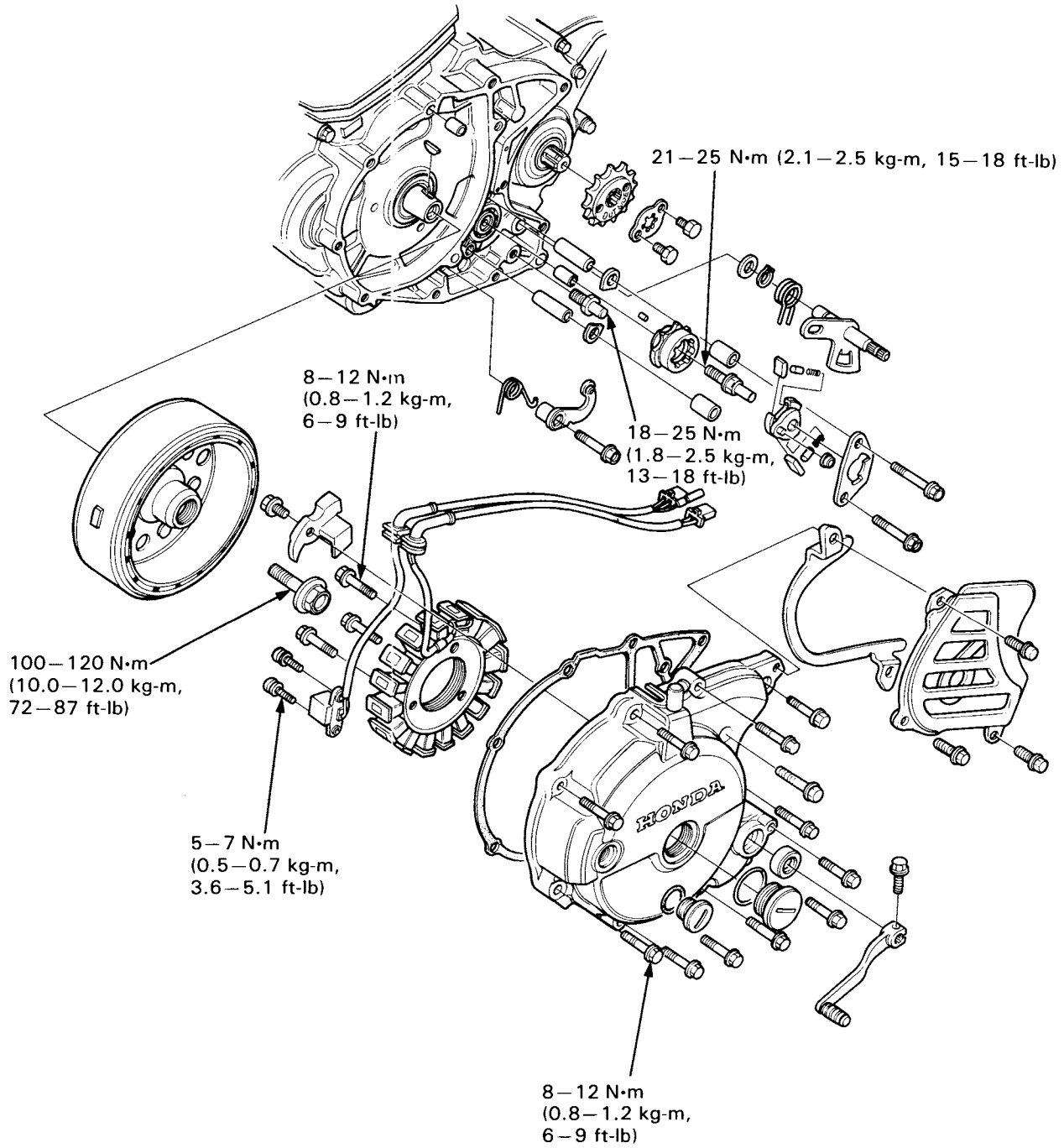

9. ALTERNATOR/GEARSHIFT LINKAGE

SERVICE INFORMATION	9-1	GEARSHIFT LINKAGE	9-4
TROUBLESHOOTING	9-1	LEFT CRANKCASE COVER	
LEFT CRANKCASE COVER REMOVAL	9-2	INSTALLATION	9-8
ALTERNATOR	9-3		

SERVICE INFORMATION

GENERAL

- This section covers removal and installation of the alternator and gearshift linkage. Refer to Section 15 for alternator inspection.

TORQUE VALUES

Gearshift return spring pin	18–25 N·m (1.8–2.5 kg-m, 13–18 ft-lb)
Flywheel bolt	100–120 N·m (10.0–12.0 kg-m, 72–87 ft-lb)
Pulse generator screw	5–7 N·m (0.5–0.7 kg-m, 3.6–5.1 ft-lb)
Stator mount bolt	8–12 N·m (0.8–1.2 kg-m, 6–9 ft-lb)
Left crankcase cover bolt	8–12 N·m (0.8–1.2 kg-m, 6–9 ft-lb)
Shift drum center bolt	21–25 N·m (2.1–2.5 kg-m, 15–18 ft-lb) – Apply a locking agent to the threads

TOOLS

Common

Flywheel holder	07725–0040000 or strap wrench, commercially available in U.S.A.
Flywheel puller	07733–0020001 or 07933–3950000

TROUBLESHOOTING

Transmission jumps out of gear

- Shift drum stopper broken.

Hard to shift

- Shift drum cam plate damage.

Gearshift pedal will not return

- Weak or broken shift return spring.
- Shift spindle binding with case.

LEFT CRANKCASE COVER REMOVAL

Remove the gearshift pedal bolt and pedal

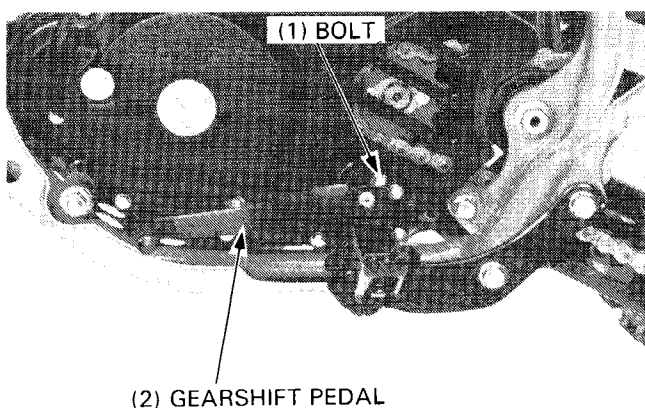

Remove the drive sprocket cover bolts and cover.

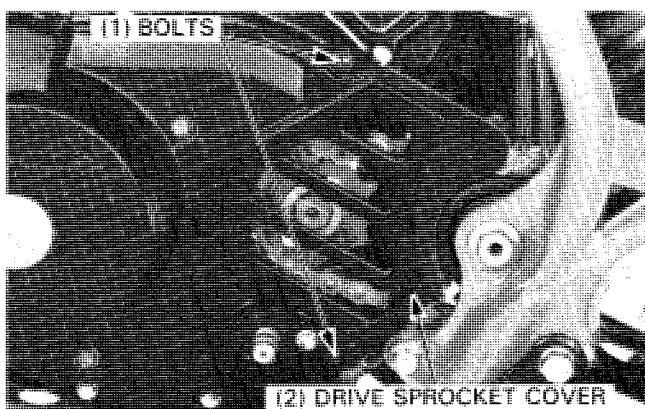

Loosen the drive chain adjuster and remove the drive chain (page 3-9).

Remove the drive chain guide.

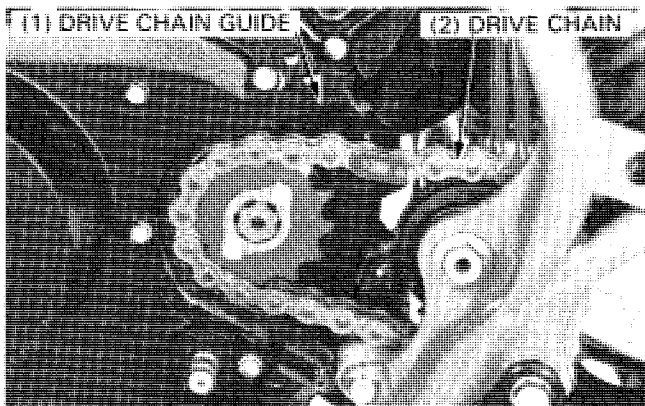

Disconnect the alternator and pulse generator wire couplers and the connector.

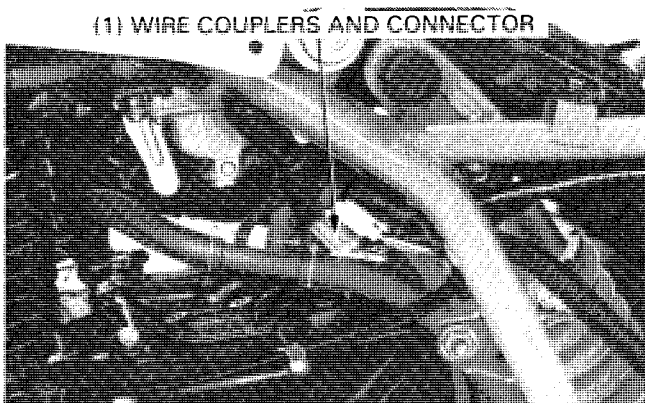

Remove the left crankcase cover bolts and cover.

Remove the dowel pins and gasket.

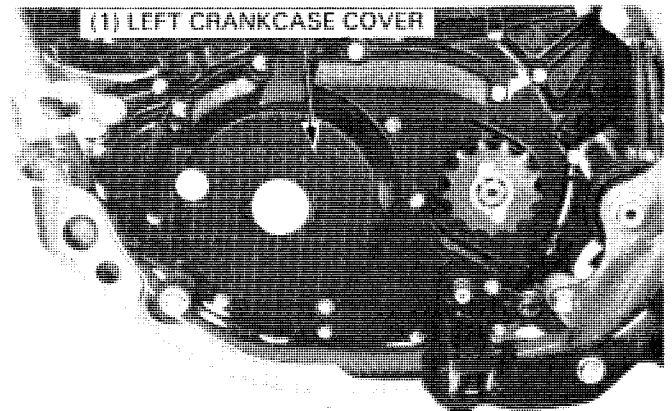

Check the gearshift shaft oil seal on the left crankcase cover for wear or damage; replace if necessary.

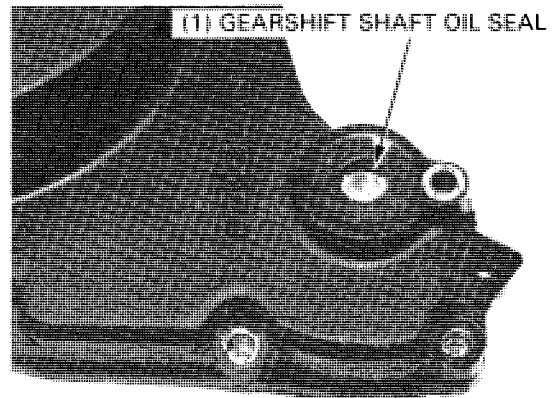

ALTERNATOR

STATOR/PULSE GENERATOR REMOVAL

Remove the wire clamp by removing the bolt.

Remove the pulse generator mounting screws and remove the pulse generator.

Remove the three stator bolts and stator.

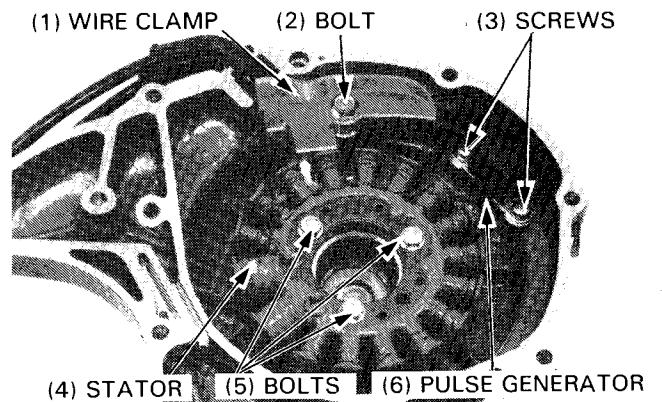

FLYWHEEL REMOVAL

Hold the flywheel with the flywheel holder and remove the flywheel bolt.

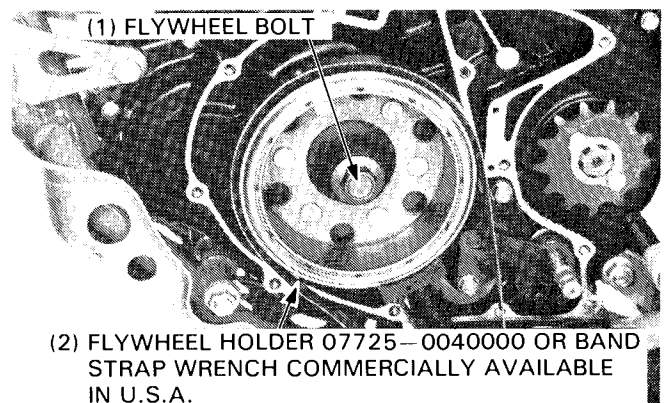

ALTERNATOR/GEARSHIFT LINKAGE

Remove the flywheel with the rotor puller.

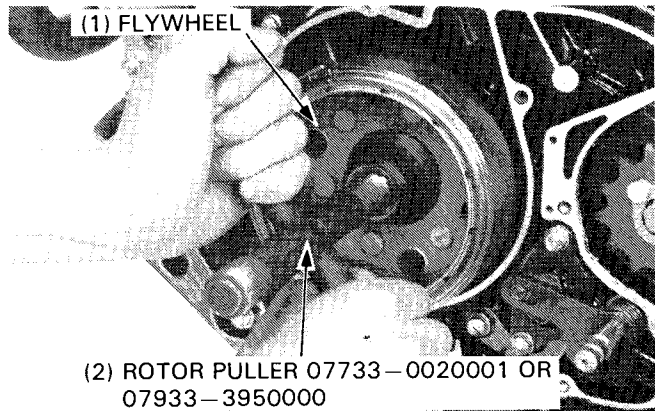

FLYWHEEL INSTALLATION

Install the flywheel by aligning the key way in the flywheel with the key on the crankshaft.

Hold the flywheel with the flywheel holder and tighten the bolt.

TORQUE: 100–120 N·m
(10.0–12.0 kg·m, 72–87 ft·lb)

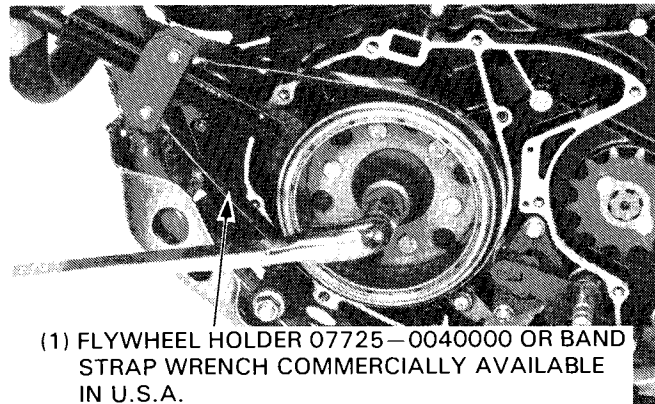

STATOR/PULSE GENERATOR INSTALLATION

Install the stator in the left crankcase cover and place the wire grommet in the groove.

Tighten the three stator mounting bolts.

TORQUE: 8–12 N·m (0.8–1.2 kg·m, 6–9 ft·lb)

Install the pulse generator using the two screws and place its wire grommet in the groove.

TORQUE: 8–12 N·m (0.8–1.2 kg·m, 6–9 ft·lb)

Install the wire clamp and tighten the bolt.

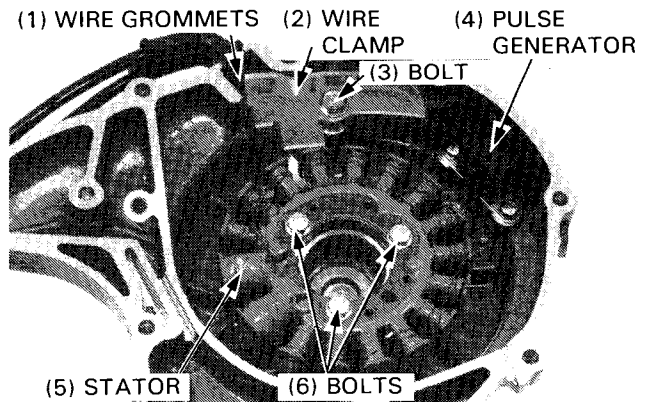

GEARSHIFT LINKAGE

REMOVAL

Pull the gearshift shaft out of the crankcase.

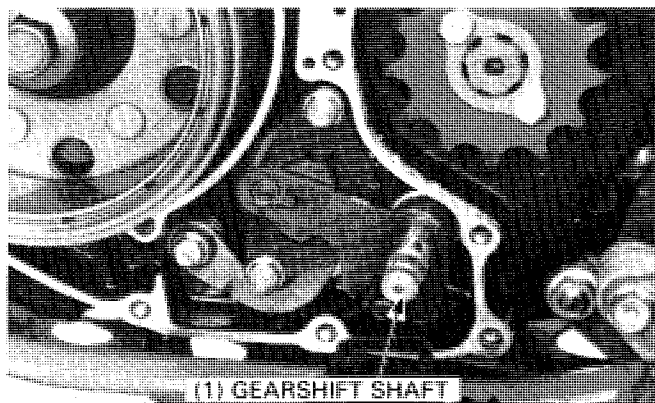

ALTERNATOR/GEARSHIFT LINKAGE

Remove the washer, snap ring and return spring from the gearshift shaft.

Check all parts for wear or damage; replace if necessary.

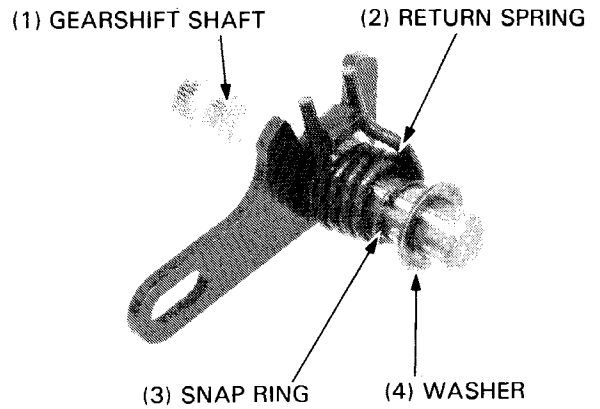

Remove the guide plate bolts, guide plate and drum shifter.

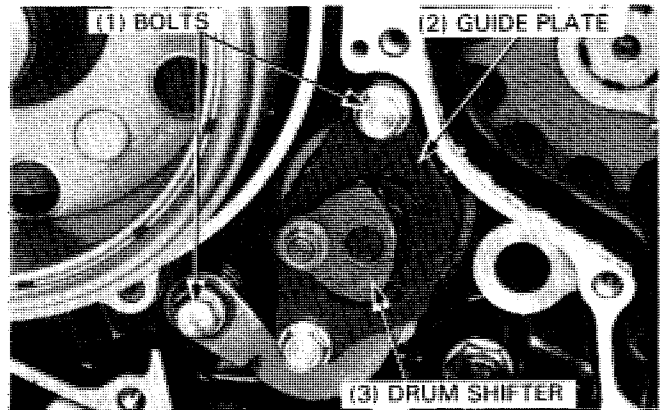

Disassemble the guide plate and drum shifter.

Check the ratchet pawls, plungers, springs and drum shifter for wear or damage and replace any damaged parts.

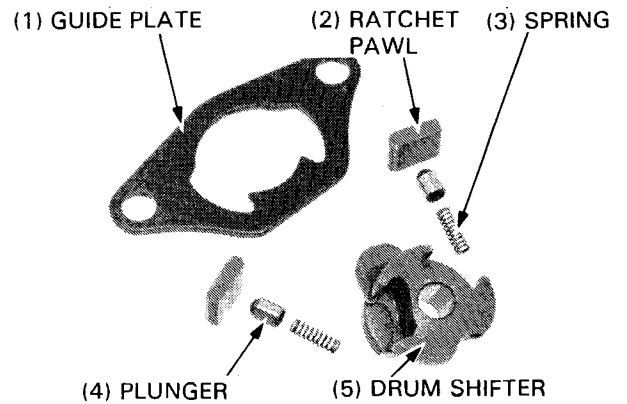

Remove the collars, dowel pins and bearing stop plates.

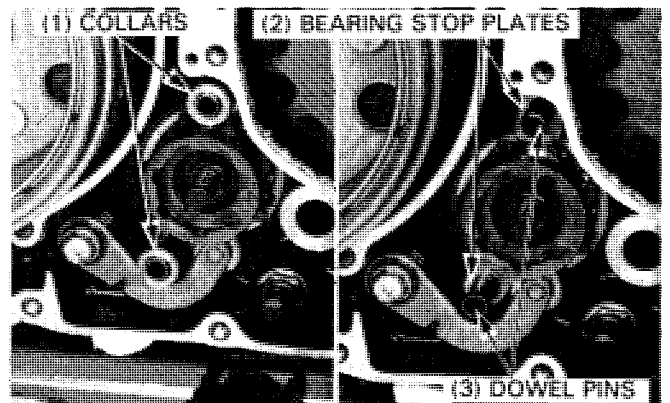

ALTERNATOR/GEARSHIFT LINKAGE

Remove the drum stopper arm bolt, arm and spring.

Remove the drum center bolt, drum center and dowel pin.

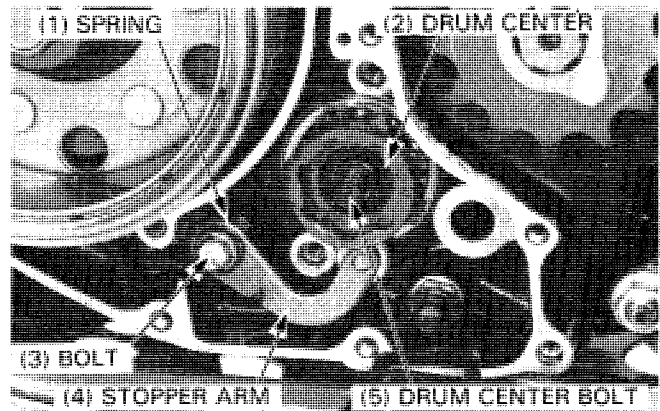

INSTALLATION

Install the spring and stopper arm using the bolt.

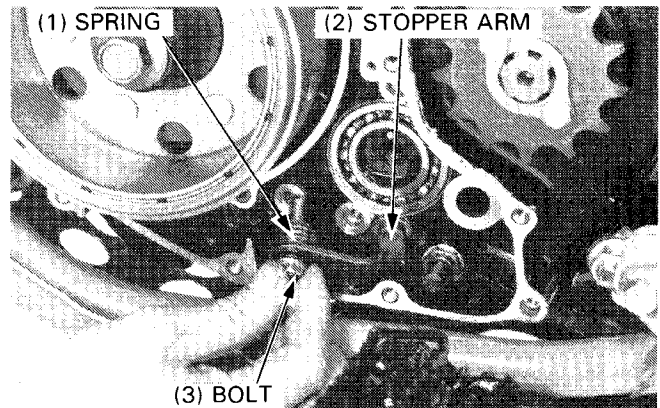

Install the dowel pin onto the gearshift drum.

Install the drum center aligning its groove with the dowel pin.

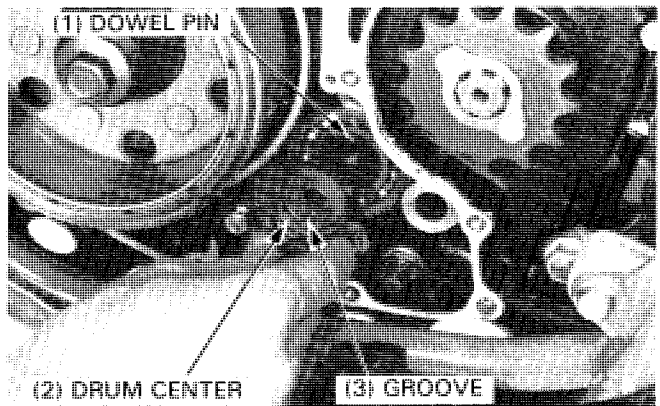

Apply a thread locking agent to the drum center bolt threads and tighten the drum center bolt.

TORQUE: 21 – 25 N·m (2.1 – 2.5 kg·m, 15 – 18 ft·lb)

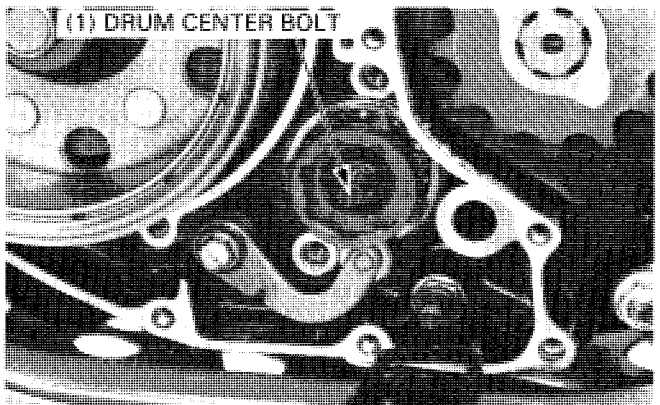

ALTERNATOR/GEARSHIFT LINKAGE

Install the bearing stop plates, dowel pins and collars.

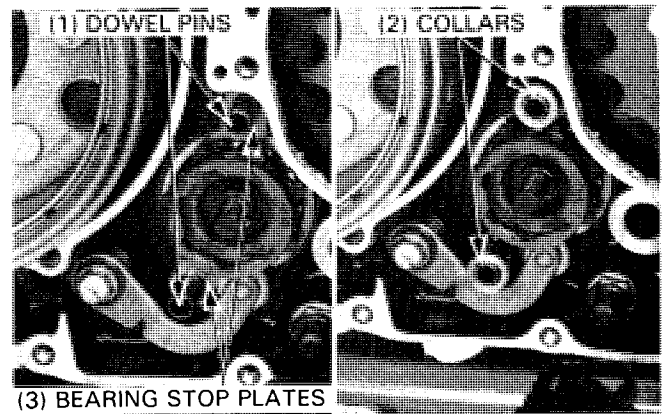

Assemble the plunger springs, plungers and ratchet pawls onto the drum shifter, then install them in the guide plate.

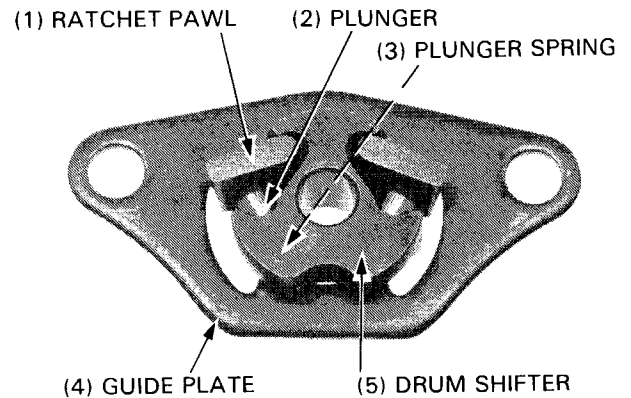

Install the guide plate and drum shifter assembly and tighten the bolts.

Install the shift collar onto the pin on the drum shifter.

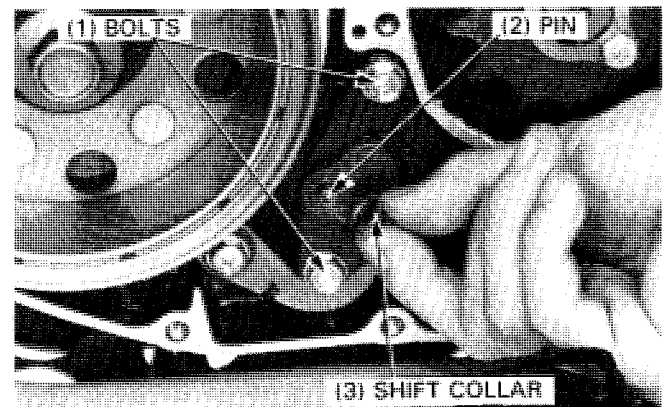

Assemble the return spring, snap ring and washer onto the shift shaft.

Install the shaft with the return spring pin between the spring ends, and the hole in the shaft arm over the shift collar.

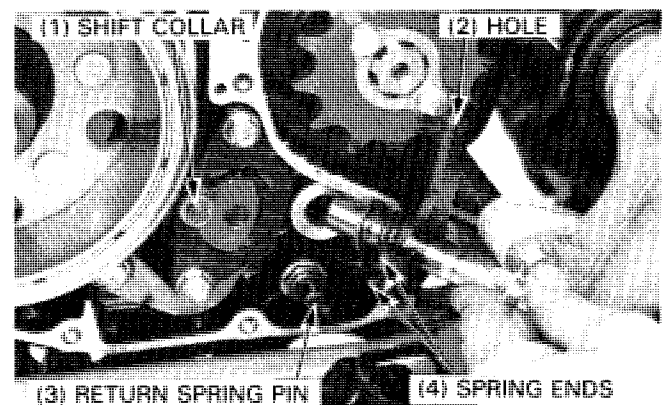

LEFT CRANKCASE COVER INSTALLATION

Install the dowel pins and a new gasket.

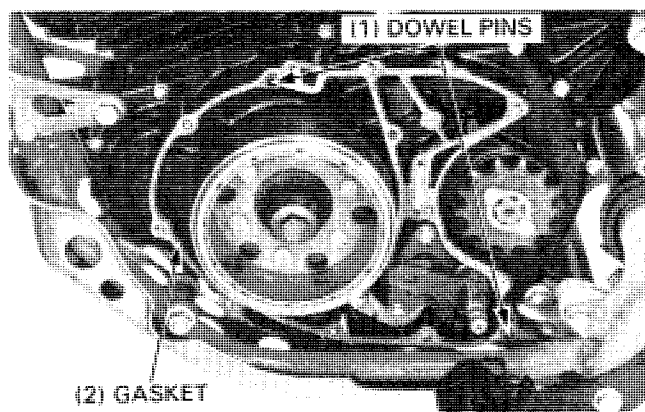

Install the left crankcase cover and tighten the cover bolts.

After '85:

Install the clutch cable guide on the left crankcase cover.

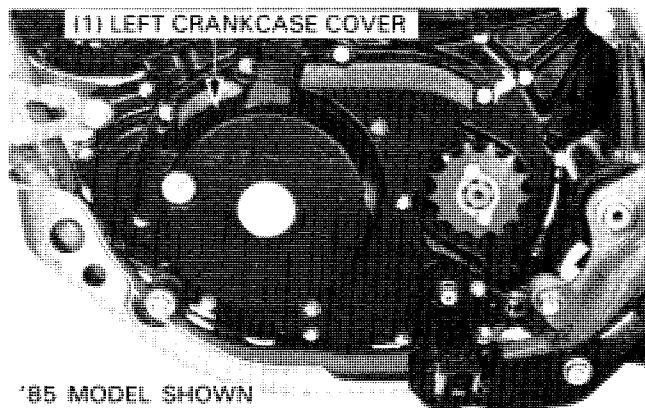

Connect the pulse generator and stator wire couplers and connector.

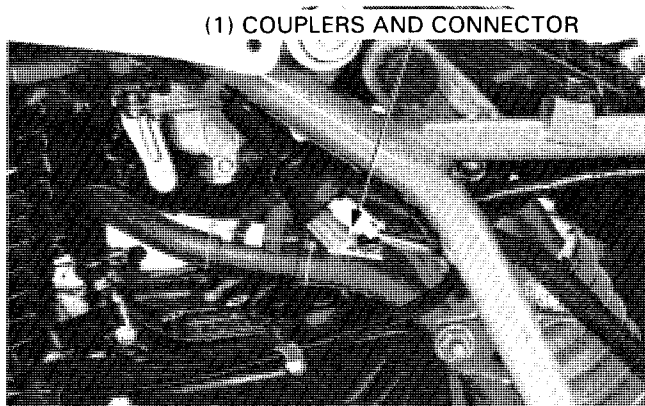

Install the chain guide and drive chain (page 3-10).

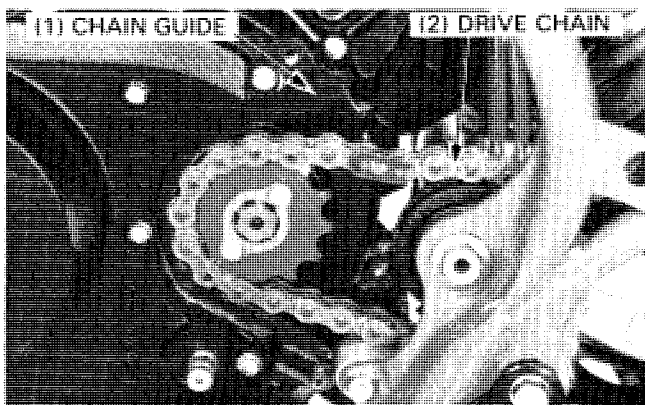

Install the drive sprocket cover using the two bolts.

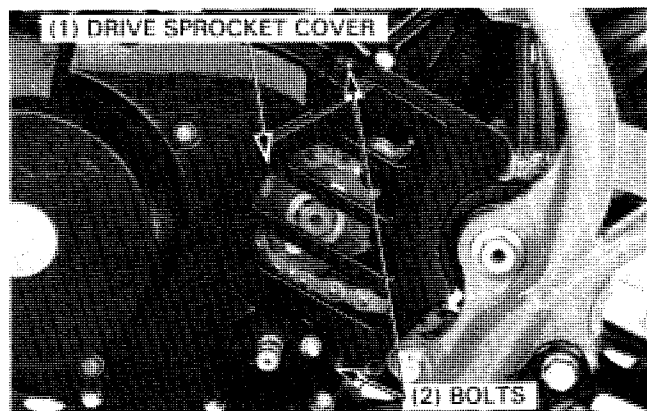

Align the punch marks and install the gearshift pedal onto the gearshift shaft, then tighten the bolt.

Check the operation of the gearshift mechanism.

Adjust the drive chain (page 3-9).

Check the ignition timing (page 3-8).

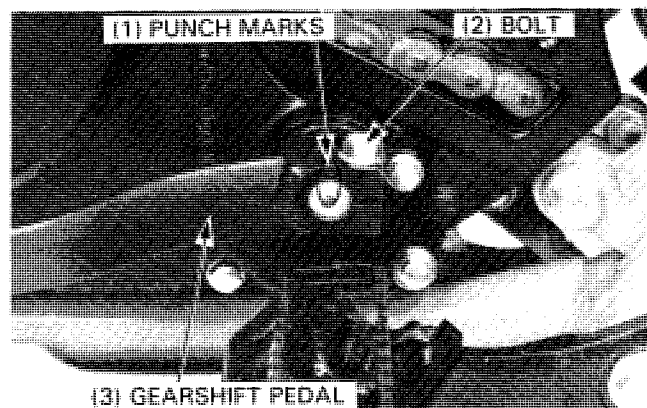

CRANKCASE/TRANSMISSION/CRANKSHAFT

8–12 N·m
(0.8–1.2 kg-m,
6–9 ft-lb)

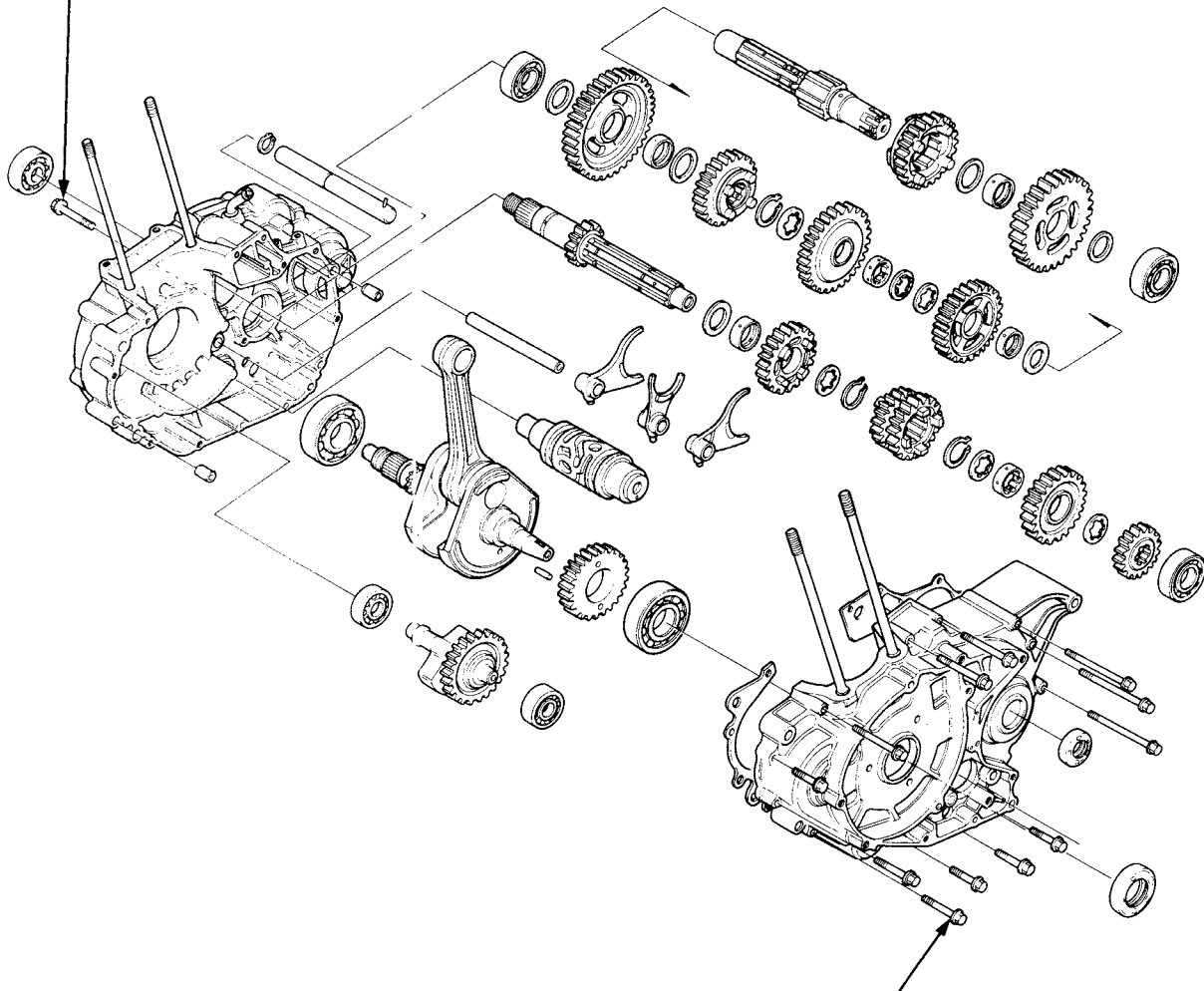

8–12 N·m
(0.8–1.2 kg-m,
6–9 ft-lb)

10. CRANKCASE/TRANSMISSION/CRANKSHAFT

SERVICE INFORMATION	10-1	TRANSMISSION	10-5
TROUBLESHOOTING	10-3	CRANKSHAFT	10-11
CRANKCASE SEPARATION	10-4	CRANKCASE ASSEMBLY	10-14

SERVICE INFORMATION

GENERAL

- Remove the following parts before separating the crankcase.
 - Cylinder head (section 6).
 - Cylinder and piston (section 7).
 - Clutch, oil pump and kick starter (section 8).
 - Alternator and gearshift linkage (section 9).
- For crankshaft and transmission repair, the crankcase must be separated.

SPECIFICATIONS

ITEM			STANDARD	SERVICE LIMIT
Crankshaft	Connecting rod small end I.D.		21.020–21.041 mm (0.8276–0.8284 in)	21.07 mm (0.830 in)
	Connecting rod big end axial clearance		0.05–0.65 mm (0.002–0.026 in)	0.80 mm (0.031 in)
	Connecting rod big end radial clearance		0.006–0.018 mm (0.0002–0.0007 in)	0.05 mm (0.002 in)
	Runout		—	0.05 mm (0.002 in)
Shift fork, shaft	Fork	I.D.	13.000–13.021 mm (0.5118–0.5126 in)	13.04 mm (0.513 in)
		Claw thickness	4.93–5.00 mm (0.194–0.197 in)	4.50 mm (0.177 in)
	Shaft O.D.		12.966–12.984 mm (0.5105–0.5112 in)	12.96 mm (0.510 in)
Transmission	Gear I.D.	M5	25.020–25.041 mm (0.9850–0.9859 in)	25.07 mm (0.987 in)
		M6	24.020–24.041 mm (0.9457–0.9465 in)	24.07 mm (0.948 in)
		C1	23.020–23.041 mm (0.9063–0.9071 in)	23.07 mm (0.908 in)
		C2	27.020–27.041 mm (1.0638–1.0646 in)	27.07 mm (1.066 in)
		C3	28.020–28.041 mm (1.1031–1.1040 in)	28.07 mm (1.105 in)
		C4	28.020–28.041 mm (1.1031–1.1040 in)	28.07 mm (1.105 in)
	Mainshaft O.D.	M5	21.959–21.980 mm (0.8645–0.8654 in)	21.93 mm (0.863 in)
		Clutch	21.959–21.980 mm (0.8645–0.8654 in)	21.93 mm (0.863 in)
	Counter-shaft O.D.	C1	19.980–19.993 mm (0.7866–0.7871 in)	19.95 mm (0.785 in)
		C2	23.959–23.980 mm (0.9433–0.9441 in)	23.93 mm (0.942 in)
C4		24.959–24.980 mm (0.9826–0.9835 in)	24.93 mm (0.981 in)	

CRANKCASE/TRANSMISSION/CRANKSHAFT

ITEM			STANDARD	SERVICE LIMIT
Trans- mission	Gear bushing	M5 O.D.	24.979–25.000 mm (0.9834–0.9843 in)	24.93 mm (0.981 in)
		M5 I.D.	22.000–22.021 mm (0.8661–0.8670 in)	22.05 mm (0.868 in)
		M6 O.D.	23.979–24.000 mm (0.9441–0.9449 in)	23.93 mm (0.942 in)
		C1 O.D.	22.979–23.000 mm (0.9047–0.9055 in)	22.93 mm (0.903 in)
		C1 I.D.	20.000–20.021 mm (0.7874–0.7882 in)	20.05 mm (0.789 in)
		C2 O.D.	26.979–27.000 mm (1.0622–1.0630 in)	26.93 mm (1.060 in)
		C2 I.D.	24.000–24.021 mm (0.9449–0.9457 in)	24.05 mm (0.947 in)
		C3 O.D.	27.979–28.000 mm (1.1015–1.1024 in)	27.93 mm (1.100 in)
		C4 O.D.	27.979–28.000 mm (1.1015–1.1024 in)	27.93 mm (1.100 in)
		C4 I.D.	25.000–25.021 mm (0.9843–0.9851 in)	25.05 mm (0.986 in)
	Gear-to- bushing clearance	M5	0.020–0.062 mm (0.0008–0.0024 in)	0.10 mm (0.004 in)
		M6	0.020–0.062 mm (0.0008–0.0024 in)	0.10 mm (0.004 in)
		C1	0.020–0.062 mm (0.0008–0.0024 in)	0.10 mm (0.004 in)
		C2	0.020–0.062 mm (0.0008–0.0024 in)	0.10 mm (0.004 in)
		C3	0.020–0.062 mm (0.0008–0.0024 in)	0.10 mm (0.004 in)
		C4	0.020–0.062 mm (0.0008–0.0024 in)	0.10 mm (0.004 in)
	Bushing-to- shaft clearance	M5	0.020–0.062 mm (0.0008–0.0024 in)	0.10 mm (0.004 in)
		C1	0.007–0.042 mm (0.0003–0.0017 in)	0.08 mm (0.003 in)
		C2	0.020–0.062 mm (0.0008–0.0024 in)	0.10 mm (0.004 in)
		C4	0.020–0.062 mm (0.0008–0.0024 in)	0.10 mm (0.004 in)

TORQUE VALUE

Crankcase bolt 8–12 N·m (0.8–1.2 kg-m, 6–9 ft-lb)

TOOLS

Special

Bearing remover, 17 mm 07936–3710300
 Remover weight 07741–0010201 or 07936–3710200
 Remover handle 07936–3710100
 Universal bearing puller 07631–0010000 or commercially available in U.S.A.
 Crankshaft assembly collar 07931–VM00100 or 07931–KF00100 and 07931–HA50100
 Shaft puller 07931–ME40000
 Thread adaptor 07931–KF00200

Common

Driver 07749–0010000
 Attachment, 72 x 75 mm 07746–0010600
 Attachment, 37 x 40 mm 07746–0010200
 Attachment, 52 x 55 mm 07746–0010400
 Pilot, 22 mm 07746–0041000
 Attachment, 42 x 47 mm 07746–0010300
 Pilot, 20 mm 07746–0040500
 Pilot, 25 mm 07746–0040600

TROUBLESHOOTING

Crankshaft noisy

- Worn connecting rod big end bearing.
- Bent connecting rod.
- Worn crankshaft main journal bearing.

Jumps out of gear

- Shift fork bent or damaged.
- Shift fork shaft bent.
- Shift claw bent.
- Gear engagement dogs or slots worn.
- Shift drum cam grooves damaged.

Hard to shift

- Incorrect clutch adjustment.
- Shift fork bent or damaged.
- Shift fork shaft bent.

CRANKCASE SEPARATION

Install the bearing stop plates, dowel pins, collars, shift guide plate and guide plate bolts temporarily to prevent the gearshift drum bearing from slipping out.

Remove the drive sprocket bolts, the fixing plate and the sprocket.

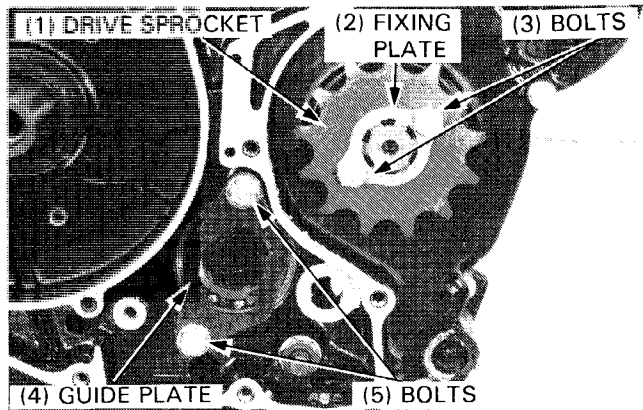

Remove the cam chain.

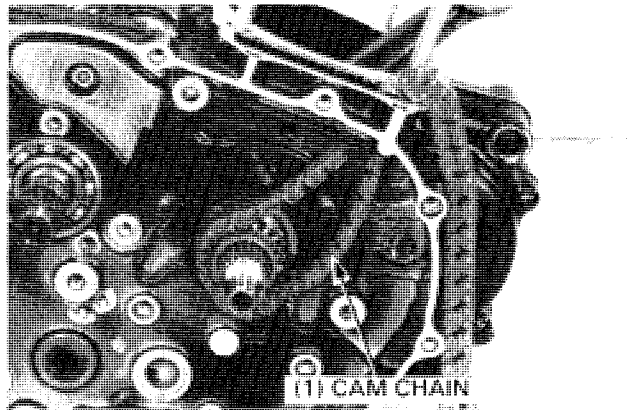

Remove the right crankcase bolt.

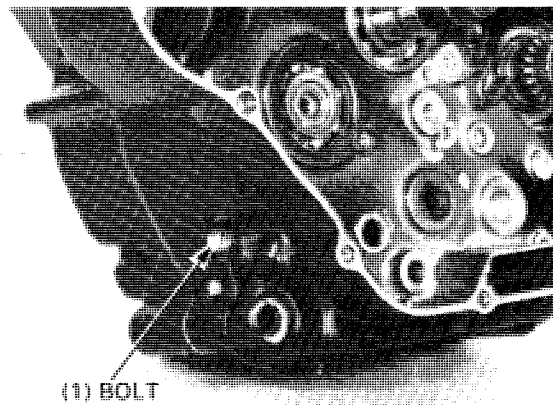

Remove the left crankcase bolts.

NOTE

- Loosen the bolts in a crisscross pattern in 2 to 3 steps to prevent crankcase distortion.

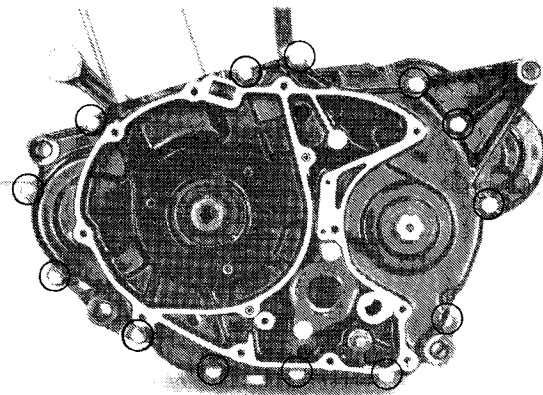

Place the engine with the left crankcase down and remove the right crankcase.

Remove the dowel pins and gasket.

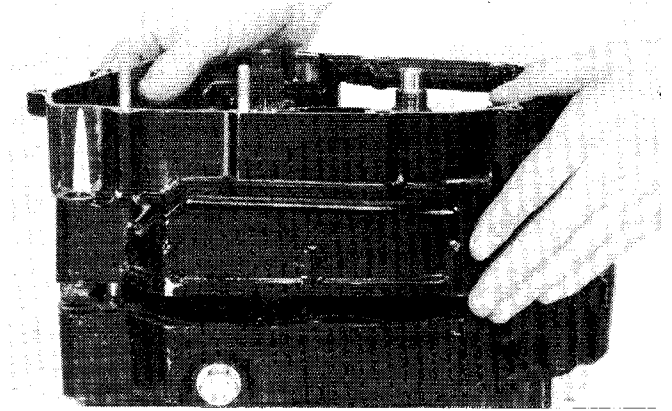

TRANSMISSION

DISASSEMBLY

Pull the gearshift fork shaft out and remove the shift forks and shift drum.

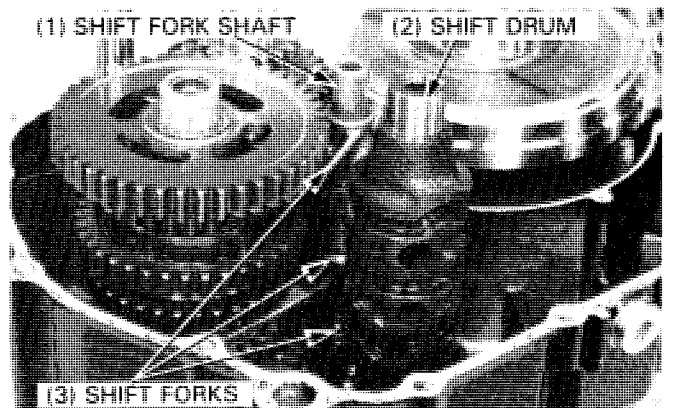

Remove the kick starter 2nd idler gear shaft.

Remove the mainshaft and countershaft as a set.

Disassemble the mainshaft and countershaft.

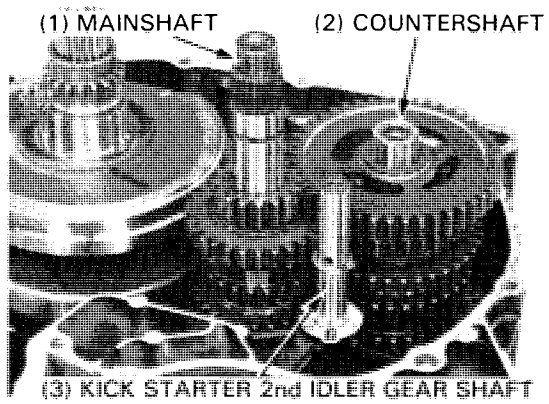

INSPECTION

Check the shift forks and shaft for wear or damage.

Measure the I.D. of the shift forks.

SERVICE LIMIT: 13.04 mm (0.513 in)

Measure the shift fork claw thickness

SERVICE LIMIT: 4.50 mm (0.177 in)

Measure the O.D. of the shift fork shaft.

SERVICE LIMIT: 12.96 mm (0.510 in)

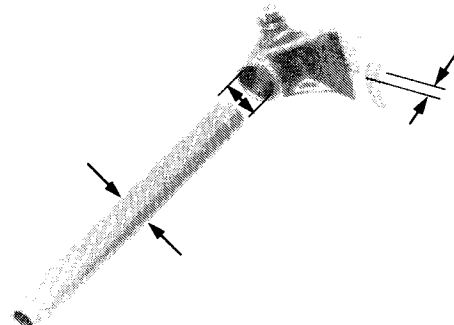

CRANKCASE/TRANSMISSION/CRANKSHAFT

Inspect the shift drum right journal for scoring, scratches, or evidence of insufficient lubrication.

Check the shift drum grooves for wear or damage.



Check the gear dogs, dog holes and teeth for excessive or abnormal wear, or evidence of insufficient lubrication.

Measure the I.D. of each gear.

SERVICE LIMIT:

- M5: 25.07 mm (0.987 in)
- M6: 24.07 mm (0.948 in)
- C1: 23.07 mm (0.908 in)
- C2: 27.07 mm (1.066 in)
- C3: 28.07 mm (1.105 in)
- C4: 28.07 mm (1.105 in)

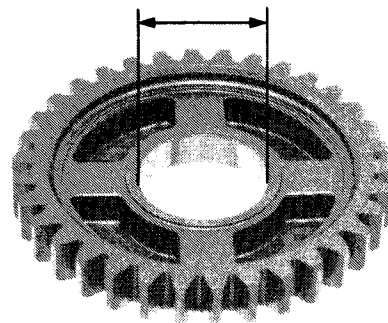

Measure the I.D. and O.D. of each gear bushing.

SERVICE LIMIT:

- M5 O.D.: 24.93 mm (0.981 in)
- M5 I.D.: 22.05 mm (0.868 in)
- M6 O.D.: 23.93 mm (0.942 in)
- C1 O.D.: 22.93 mm (0.903 in)
- C1 I.D.: 20.05 mm (0.789 in)
- C2 O.D.: 26.93 mm (1.060 in)
- C2 I.D.: 24.05 mm (0.947 in)
- C3 O.D.: 27.93 mm (1.100 in)
- C4 O.D.: 27.93 mm (1.100 in)
- C4 I.D.: 25.05 mm (0.986 in)

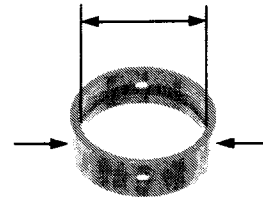

Calculate gear-to-bushing clearance.

SERVICE LIMIT:

- M5: 0.10 mm (0.004 in)
- M6: 0.10 mm (0.004 in)
- C1: 0.10 mm (0.004 in)
- C2: 0.10 mm (0.004 in)
- C3: 0.10 mm (0.004 in)
- C4: 0.10 mm (0.004 in)

Measure the O.D. of the mainshaft and countershaft.

SERVICE LIMIT:

- M5: 21.93 mm (0.863 in)
- C1: 19.95 mm (0.785 in)
- C2: 23.93 mm (0.942 in)
- C4: 24.93 mm (0.981 in)
- AT clutch outer: 21.93 mm (0.863 in)

Calculate the gear bushing-to-shaft clearance.

SERVICE LIMIT:

- M5: 0.10 mm (0.004 in)
- C1: 0.08 mm (0.003 in)
- C2: 0.10 mm (0.004 in)
- C4: 0.10 mm (0.004 in)

Check the transmission bearings for excessive play or damage and replace if necessary.

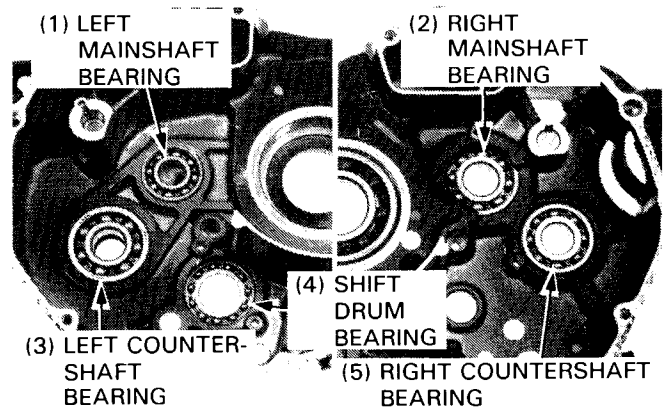
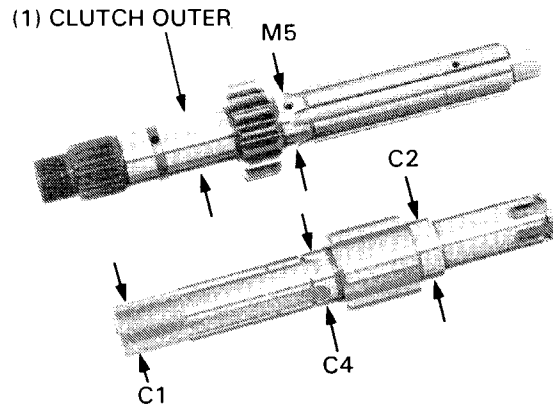

BEARING REPLACEMENT

Remove the left mainshaft bearing using the bearing remover.

TOOLS:

- (1) BEARING REMOVER HANDLE 07936-3710100
- (2) REMOVER WEIGHT 07936-3710200 or 07741-0010201
- (3) BEARING REMOVER, 17 mm 07936-3710300

Remove the countershaft oil seal and all transmission bearings.

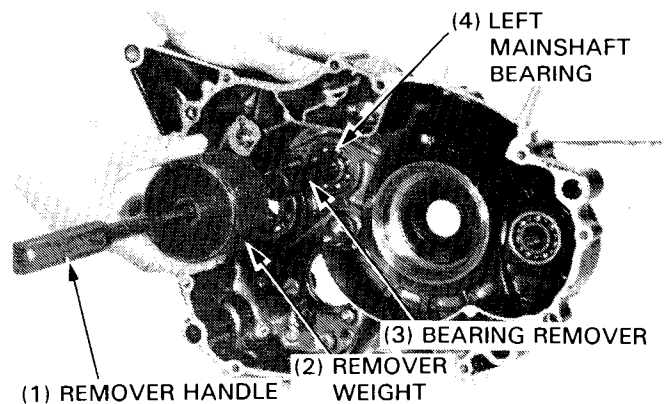

Drive new bearings in using the following tools:

Left mainshaft bearing:

- DRIVER 07749-0010000
- ATTACHMENT, 37 x 40 mm 07746-0010200

NOTE

- Install the left mainshaft bearing with its sealed end facing down.

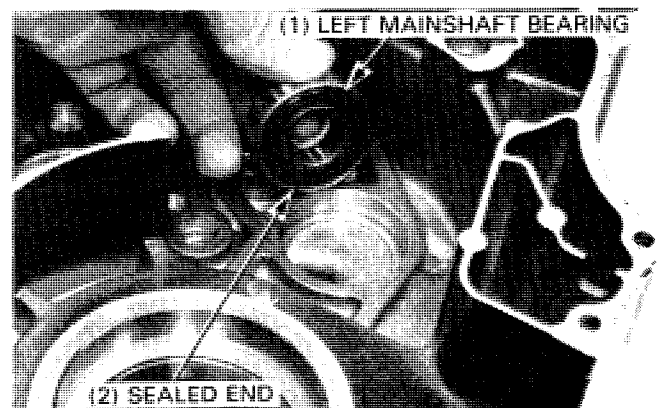

CRANKCASE/TRANSMISSION/CRANKSHAFT

Left countershaft bearing:

DRIVER 07749-0010000

ATTACHMENT, 52 x 55 mm 07746-0010400

PILOT, 20 mm 07746-0040500

Gearshift drum bearing:

DRIVER 07749-0010000

ATTACHMENT, 42 x 47 mm 07746-0010300

PILOT, 25 mm 07746-0040600

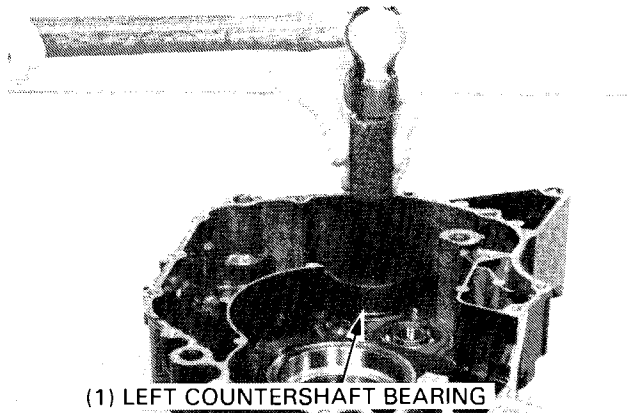

Right mainshaft bearing:

DRIVER 07749-0010000

ATTACHMENT, 52 x 55 mm 07746-0010400

PILOT, 22 mm 07746-0041000

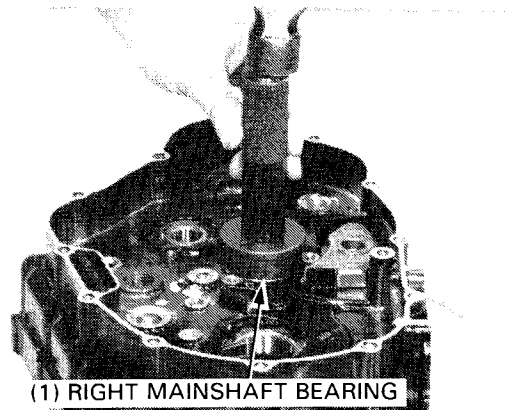

Right countershaft bearing:

DRIVER 07749-0010000

ATTACHMENT, 42 x 47 mm 07746-0010300

PILOT, 20 mm 07746-0040500

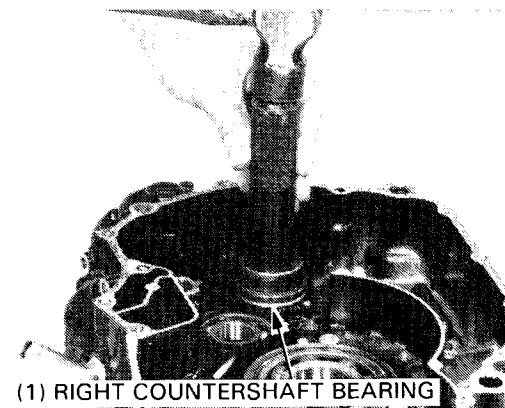

Install a new countershaft oil seal.

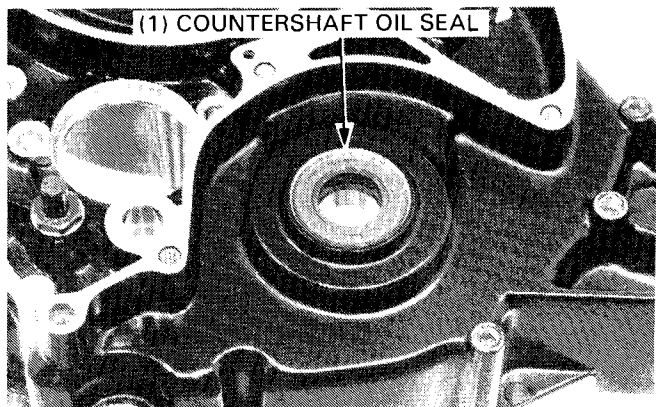

ASSEMBLY

Coat all parts with oil.

Assemble the transmission shafts and gears, noting the locations of the thrust washers and snap rings.

Make sure that the snap rings are seated properly.

Align the C4 gear lock washer tabs with the grooves in the spline washer as shown.

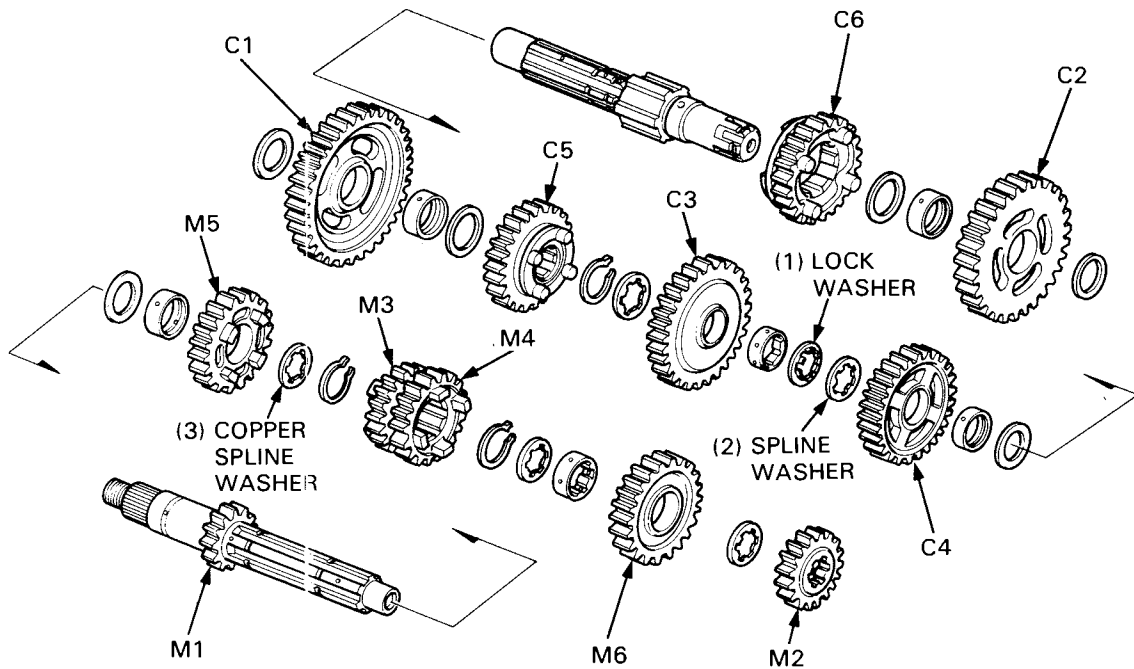
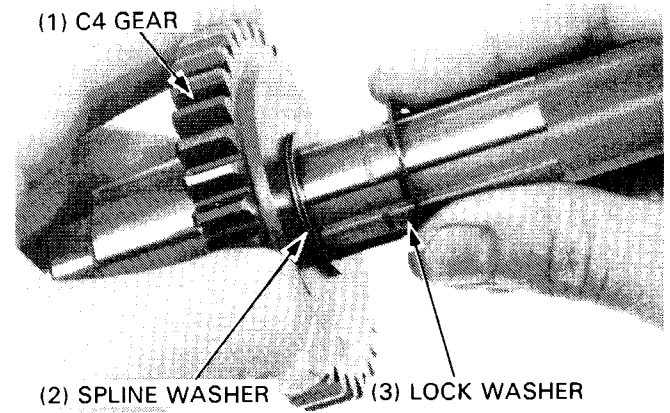

CRANKCASE/TRANSMISSION/CRANKSHAFT

Install the mainshaft and countershaft as a set into the left crankcase.

Install the kick starter 2nd idler gear shaft, aligning its dowel pin with the groove in the crankcase.

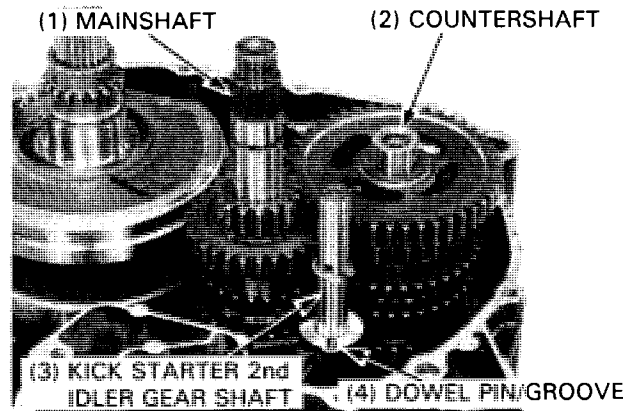

Install the gearshift forks with their marks facing up.

NOTE

- The gearshift forks have marks: L for left, C for center and R for right.

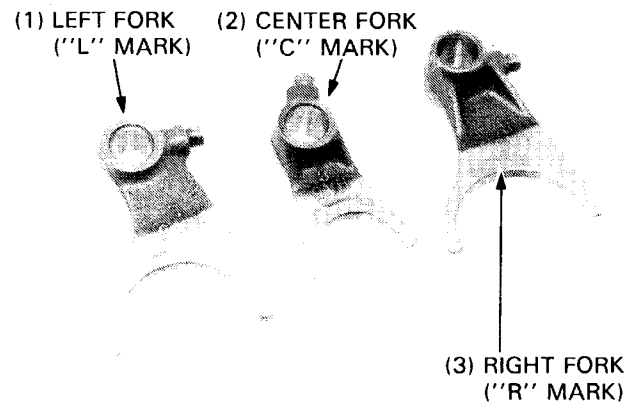

Install the gearshift drum and align each shift fork guide pin with its guide groove in the drum.

Insert the shift fork shaft through the forks into the hole in the left crankcase.

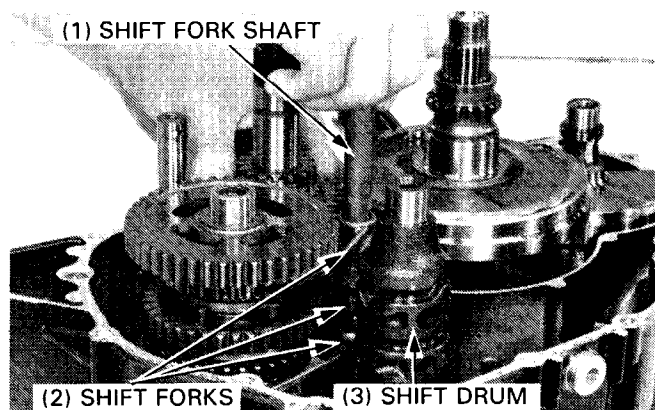

CRANKSHAFT

REMOVAL

Remove the transmission (page 10-5)

Remove the crankshaft from the left crankcase using a hydraulic press.

CAUTION

- *Take care that the crankshaft and balancer don't fall when removing the crankshaft.*

Remove the balancer.

If the left crankshaft bearing remains on the crankshaft, remove it with a bearing puller. If the bearing remains in the left crankcase, remove it with driver 07749-0010000 and attachment, 37 x 40 mm 07746-0010200. Discard the left crankshaft bearing.

NOTE

- Always replace the left bearing with a new one whenever the crankshaft is removed from the left crankcase.

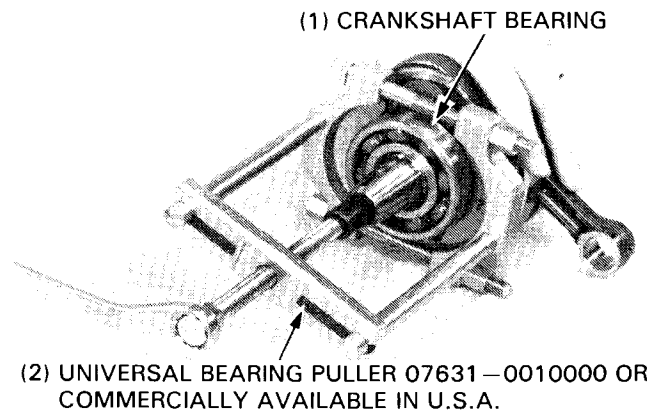
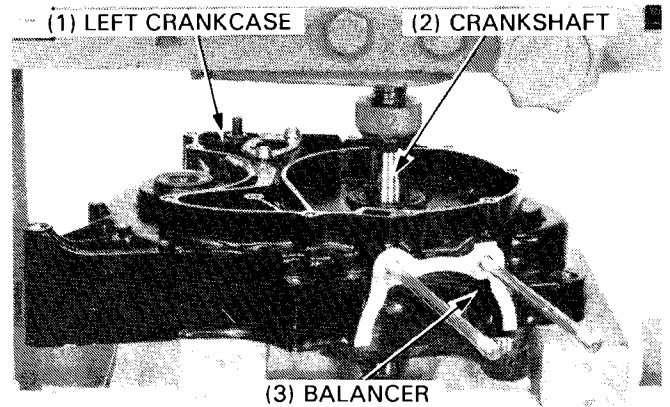

INSPECTION

Set the crankshaft on a stand or V-blocks and read the runout using dial indicators.

SERVICE LIMIT: 0.05 mm (0.002 in)

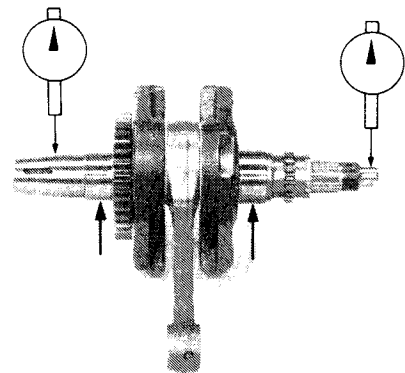

Measure the side clearance of the connecting rod big end.

SERVICE LIMIT: 0.80 mm (0.031 in)

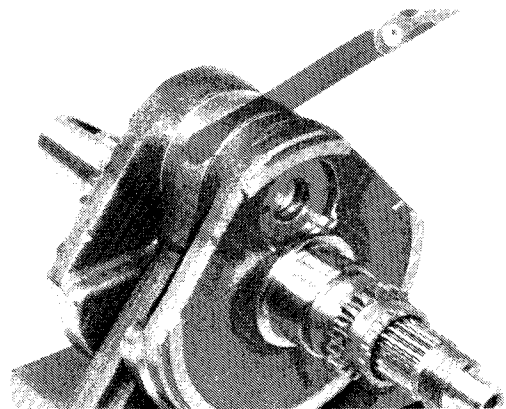

CRANKCASE/TRANSMISSION/CRANKSHAFT

Measure the connecting rod radial clearance at two points in the directions indicated by the arrows.

SERVICE LIMIT: 0.05 mm (0.002 in)

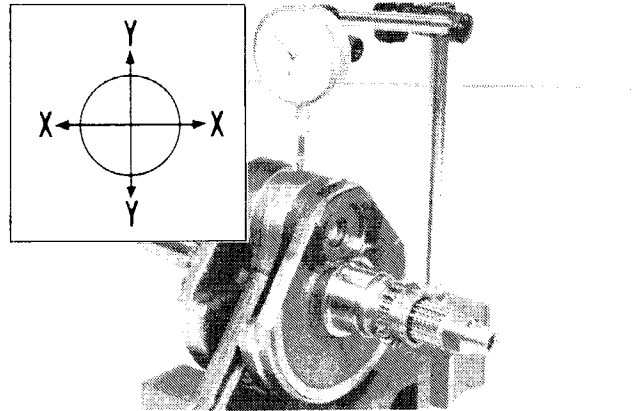

BEARING INSPECTION/REPLACEMENT

Turn the inner race of each bearing with your finger. The bearings should turn smoothly and quietly. Also check that the bearing outer race fits tightly in the crankcase.

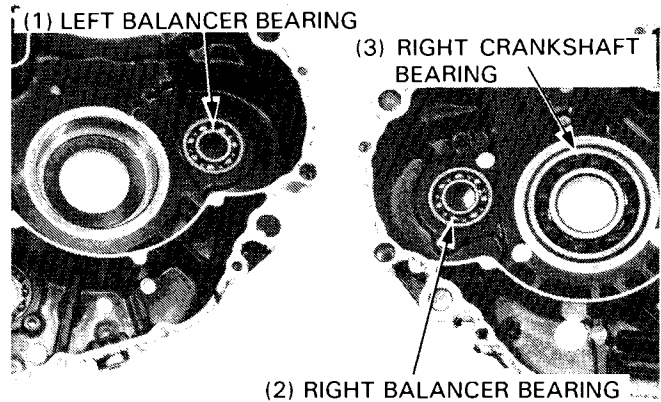

Remove the balancer bearings using the bearing remover.

TOOLS:

- (1) REMOVER WEIGHT 07936-3710200 or 07741-0010201
- (2) BEARING REMOVER, 17 mm 07936-3710300
- (3) REMOVER HANDLE 07936-3710100

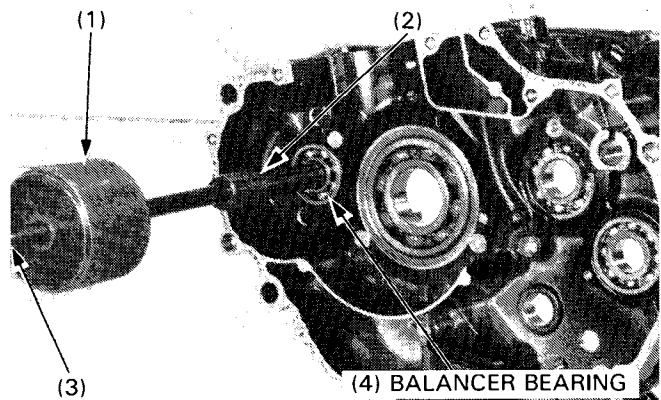

Drive in new balancer bearings.

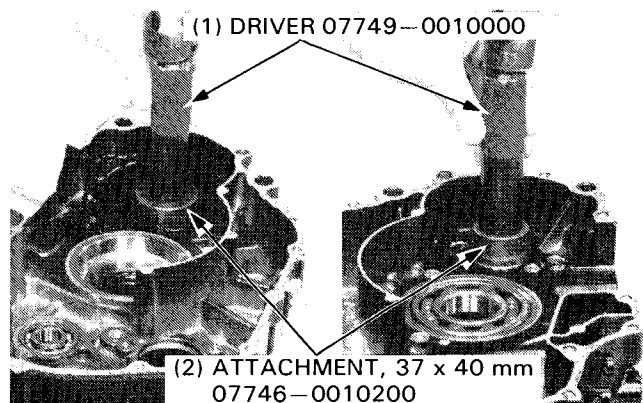

Remove the right crankshaft bearing.
Drive a new right crankshaft bearing into the right crankcase.

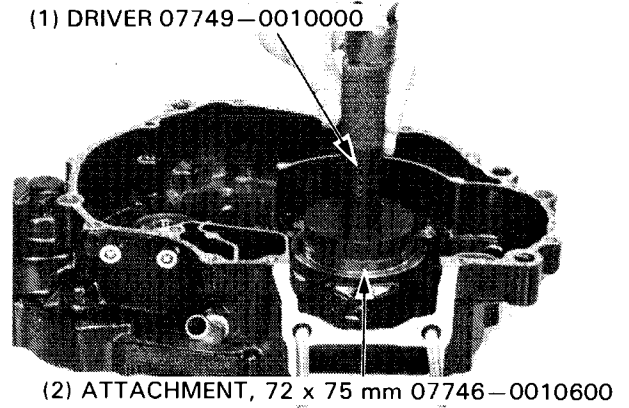

INSTALLATION

Drive a new left crankshaft bearing into the left crankcase.

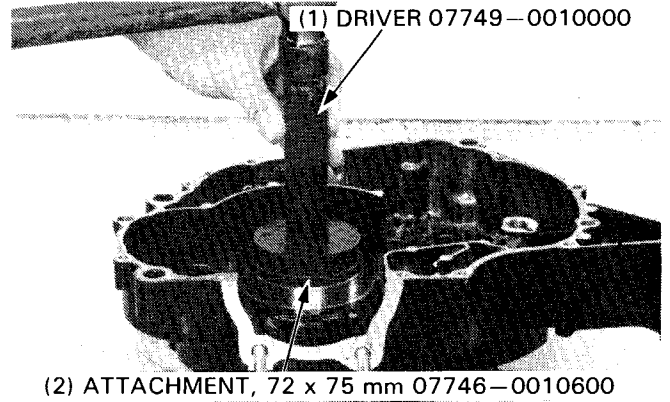

Align the timing marks on the crankshaft and balancer gears and place them in the left crankcase.

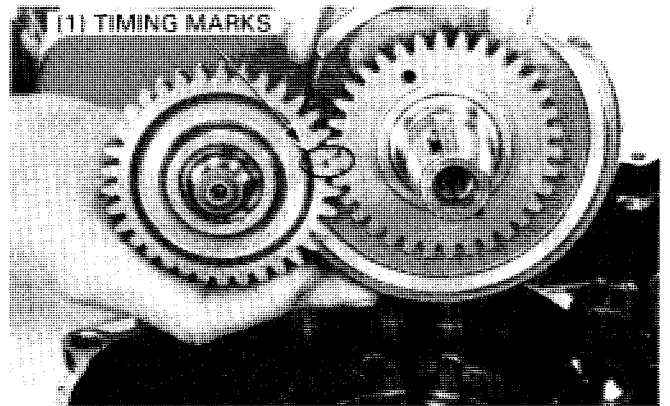

Install the crankshaft in the left crankcase using the special tools.

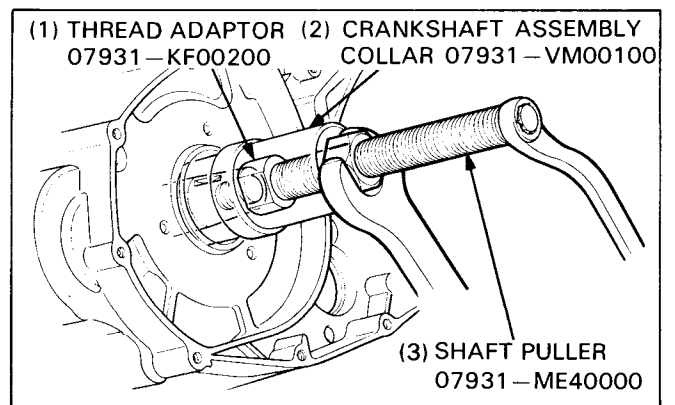

CRANKCASE/TRANSMISSION/CRANKSHAFT

Make sure that the timing marks on the balancer and crank weights are aligned.

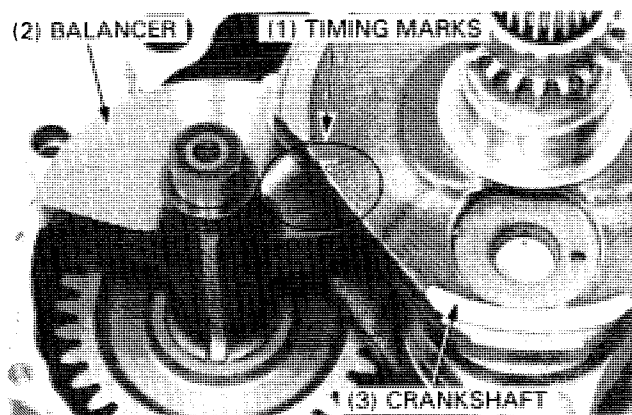

CRANKCASE ASSEMBLY

Install the new dowel pins and a new gasket.

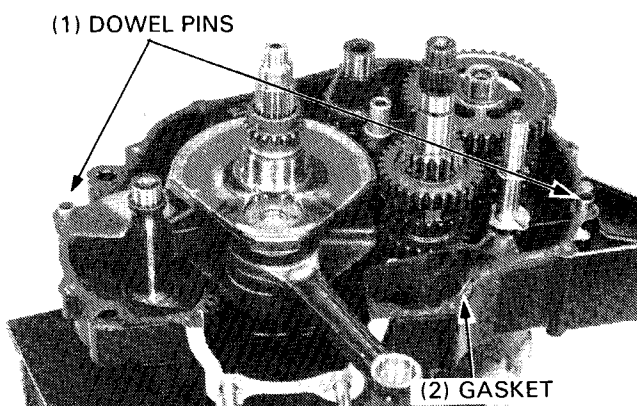

Place the right crankcase over the left crankcase.

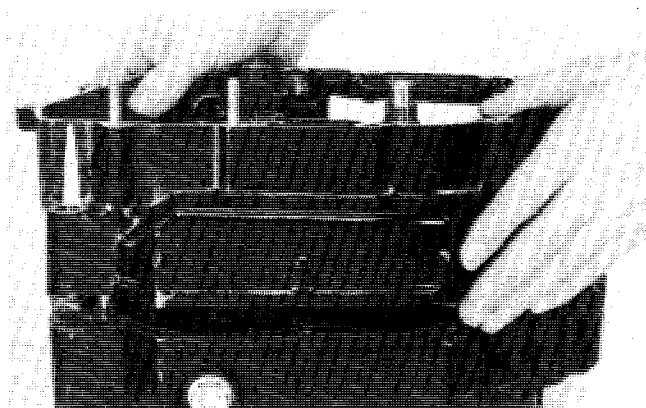

Tighten the left crankcase bolts.

TORQUE: 8–12 N·m (0.8–1.2 kg·m, 6–9 ft·lb)

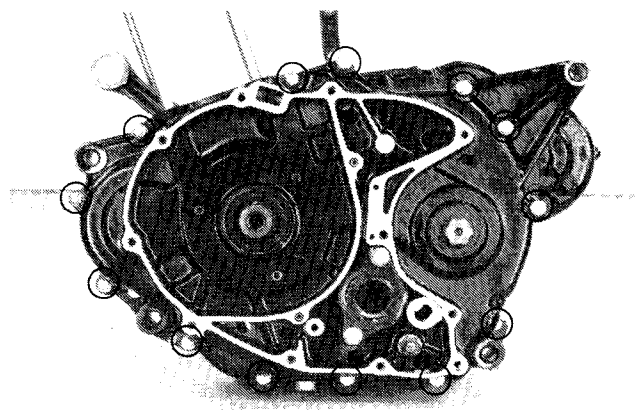

Tighten the right crankcase bolt to the same torque.

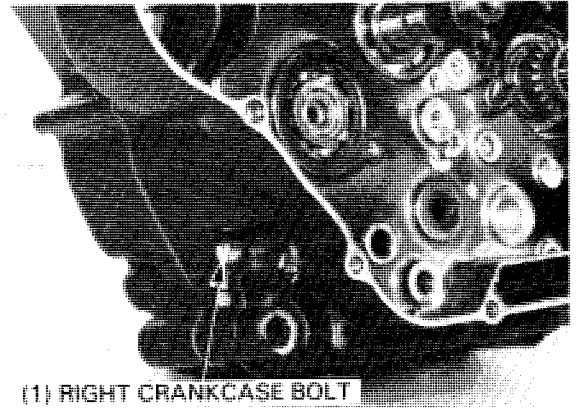

Install the cam chain.

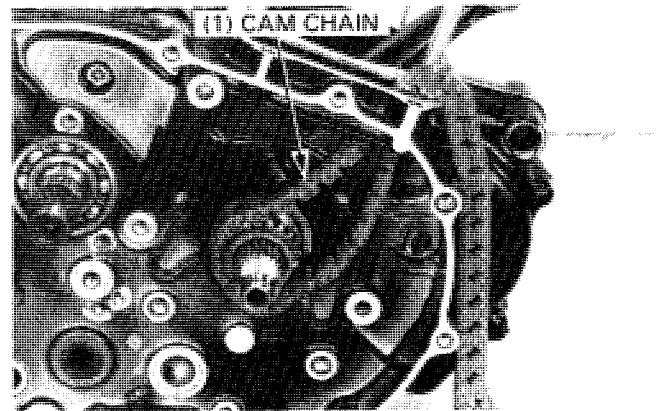

Install the drive sprocket and fixing plate and tighten the bolts.

Remove the shift guide plate, collars, dowel pins, bearing stop plates and bolts.

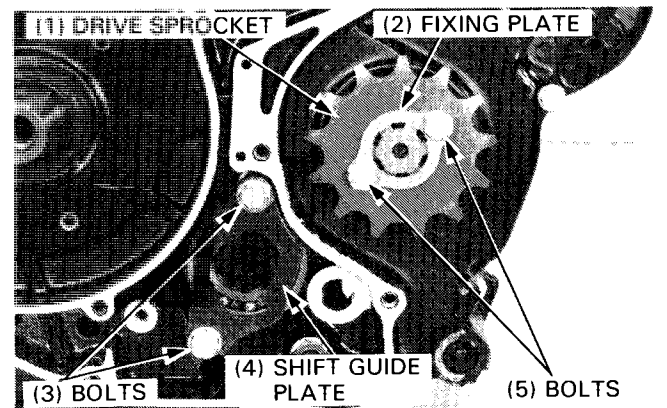

FRONT WHEEL/SUSPENSION/STEERING

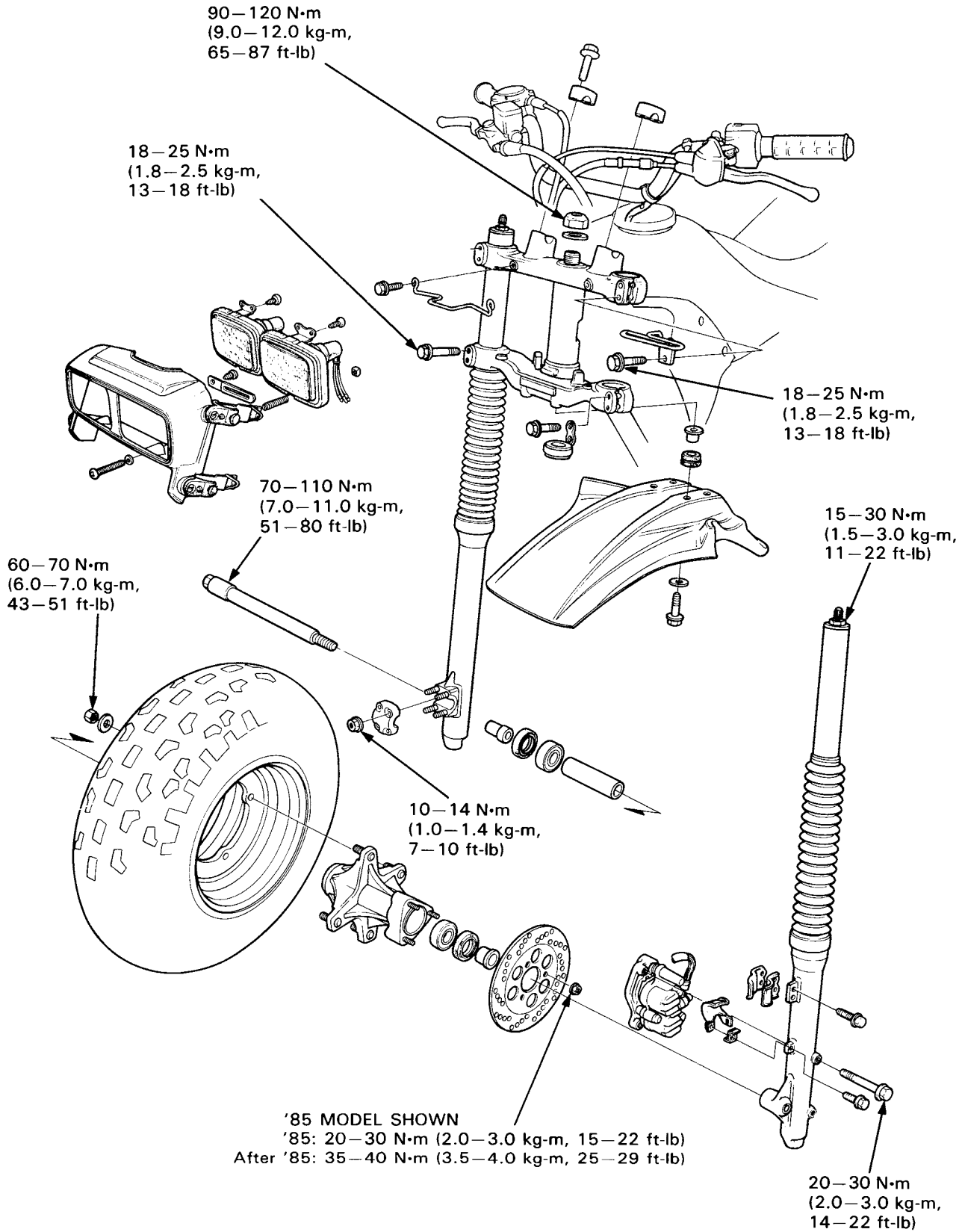

11. FRONT WHEEL/SUSPENSION/STEERING

SERVICE INFORMATION	11-1	FRONT WHEEL	11-6
TROUBLESHOOTING	11-2	FRONT FORK	11-14
HANDLEBAR	11-3	STEERING STEM	11-21

SERVICE INFORMATION

GENERAL

- This section covers maintenance of the front wheel, front fork, steering system and tire removal/repair.
- A jack or other support is required to support the ATC.

SPECIFICATIONS

ITEM		STANDARD	SERVICE LIMIT
Axle runout		—	0.5 mm (0.02 in)
Fork spring free length	Upper	113.5 mm (4.47 in)	109.4 mm (4.31 in)
	Lower	493.3 mm (19.42 in)	483.4 mm (19.03 in)
Fork tube runout		—	0.2 mm (0.01 in)
Wheel rim runout	Radial	—	4.0 mm (0.16 in)
	Axial	—	4.0 mm (0.16 in)
Fork oil capacity		290 cc (9.8 US oz, 10.2 Imp oz)	—

11

TORQUE VALUES

Wheel nut		60–70 N•m (6.0–7.0 kg-m, 43–51 ft-lb)
Axle		70–110 N•m (7.0–11.0 kg-m, 51–80 ft-lb)
Axle holder nut		10–14 N•m (1.0–1.4 kg-m, 7–10 ft-lb)
Brake disc nut	'85:	20–30 N•m (2.0–3.0 kg-m, 15–22 ft-lb)
Brake disc bolt	After '85:	35–40 N•m (3.5–4.0 kg-m, 25–29 ft-lb)
Caliper bracket		20–30 N•m (2.0–3.0 kg-m, 15–22 ft-lb)
Fork socket bolt		15–25 N•m (1.5–2.5 kg-m, 11–18 ft-lb)
Fork tube cap		15–30 N•m (1.5–3.0 kg-m, 11–22 ft-lb)
Fork pinch bolt		18–25 N•m (1.8–2.5 kg-m, 13–18 ft-lb)
Fork boot band		0.6–1.2 N•m (0.06–0.12 kg-m, 0.4–0.9 ft-lb)
Steering bearing adjustment nut	Initial	25–35 N•m (2.5–3.5 kg-m, 18–25 ft-lb)
	Final '85:	7–8 N•m (0.7–0.8 kg-m, 5–6 ft-lb)
	Final After '85:	10–11 N•m (1.0–1.1 kg-m, 7–8 ft-lb)
Steering stem nut		90–120 N•m (9.0–12.0 kg-m, 65–87 ft-lb)

FRONT WHEEL/SUSPENSION/STEERING

TOOLS

Special

Universal bead breaker	GN—AH—958—BB1 (U.S.A. only)
Hex. wrench, 6 mm	07917—3230000 or equivalent commercially available in U.S.A.
Snap ring pliers	07914—3230001 or equivalent commercially available in U.S.A.
Fork seal driver	07947—KA50100
Fork seal driver attachment	07947—KL40100 } or 07947—3710101
Steering stem socket	07916—3710100
Ball race remover	07953—3330000
Steering stem driver	07946—4300101 or 07946—MB00000 and GN—HT—54 (U.S.A. only)
Ball race driver	07946—3290000

Common

Bearing remover expander	07746—0050100
Bearing remover collet, 15 mm	07746—0050400 } or equivalents commercially available in U.S.A.
Driver	07749—0010000
Attachment, 42 x 47 mm	07746—0010300
Pilot, 15 mm	07746—0040300
Extension bar	07716—0020500 or equivalent commercially available in U.S.A.
Lock nut wrench, 30 x 32 mm	07716—0020400 or equivalent commercially available in U.S.A.
Tire bead breaker set	07772—0050000 not available in U.S.A.

TROUBLESHOOTING

Hard steering

- Steering stem nut too tight.
- Faulty steering stem bearings.
- Damaged steering stem ball race and/or cone race.
- Insufficient tire pressure.

Steers to one side or does not track straight

- Bent front forks.
- Bent front axle, wheel installed incorrectly.
- Unequal rear tire pressure or circumference.

Front wheel wobbling

- Bent rim.
- Worn front wheel bearing.
- Faulty tire.
- Axle not tightened properly.

Soft suspension

- Weak fork springs.
- Insufficient fluid/air in front forks.

Hard suspension

- Incorrect fluid/air in front forks.
- Fork damaged.

Front suspension noise

- Slider binding.
- Loose front fork fasteners.
- Insufficient fluid in forks.

HANDLEBAR

REMOVAL

Remove the throttle housing and front brake master cylinder from the handlebar.

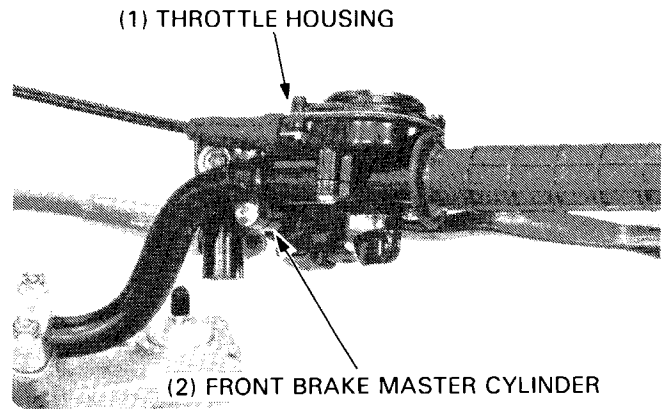

Remove the clutch/parking brake lever bracket and switch housing from the handlebar.

Remove the switch wire bands.

Remove the handlebar grips if necessary.

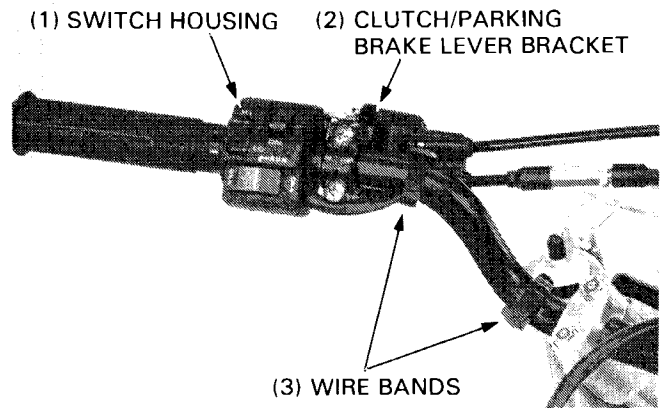

Remove the handlebar upper holders and the handlebar.

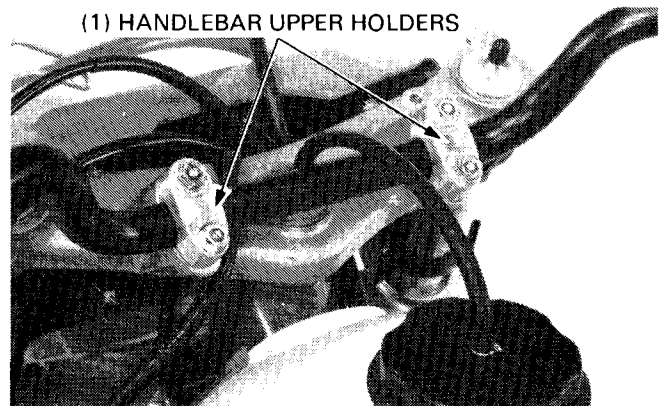

INSTALLATION

Place the handlebar onto the lower holders, aligning the punch mark on the handlebar with the top of the lower holder.

Install the handlebar upper holders with the punch marks forward.

Tighten the front bolts first, then tighten the rear bolts.

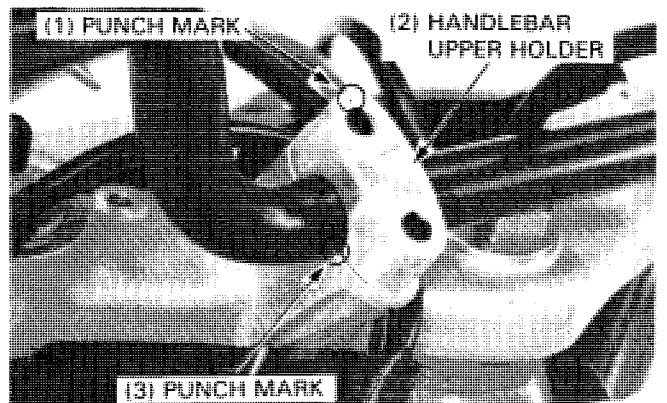

FRONT WHEEL/SUSPENSION/STEERING

Apply Honda Bond A or Honda Hand Grip Cement (U.S.A. only) to the inside surface of the grips and to the clean surfaces of the right and left handlebar end. Wait 3-5 minutes and install the grips. Rotate the grips for even application of the adhesive.

NOTE

- Allow the adhesive to dry for an hour before using.

Place the clutch/parking brake lever bracket on the handlebar and install the holder with the "UP" mark facing up.

Align the bracket holder end with the punch mark on the handlebar and tighten the upper screw first, then tighten the lower screw.

Install the switch housing, aligning its mating surface with the punch mark on the handlebar.

Tighten the upper screw first, then tighten the lower screw.

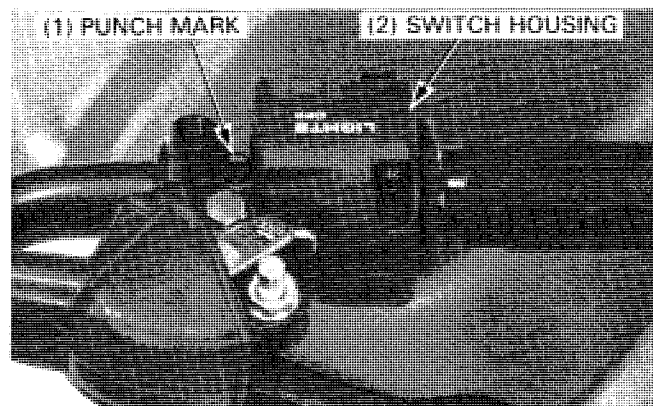

Install the handlebar switch wire bands.

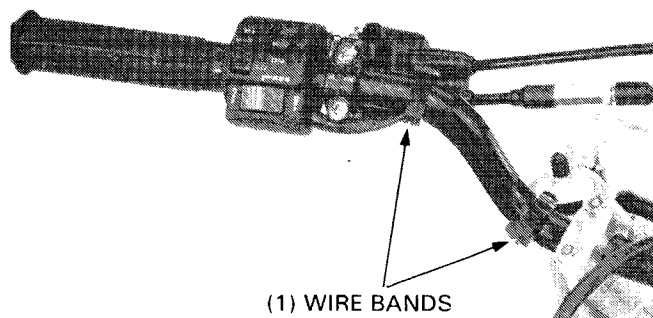

Place the front brake master cylinder on the handlebar and install the holder with the "UP" mark facing up.

Align the master cylinder holder end with the punch mark on the handlebar and tighten the upper screw first, then tighten the lower screw.

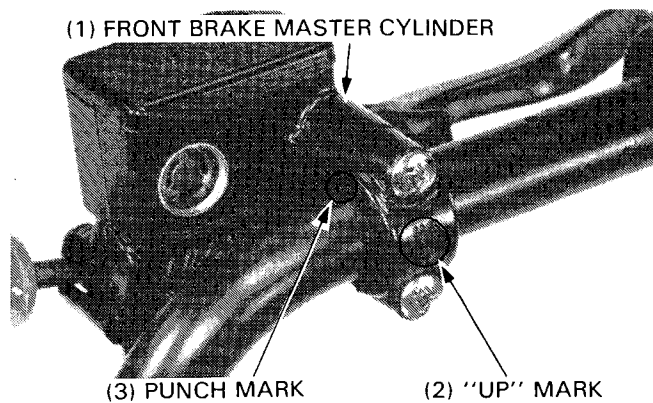

Place the throttle housing on the handlebar and loosely install the holder and screws.

Align the lower end of the throttle housing with the punch mark on the handlebar, and tighten the forward screw first, then tighten the rear screw.

Inspect the following after installing the handlebar:

- Clutch lever free play (page 3-16).
- Throttle lever free play and return (page 3-7).
- Operation of parking brake lever (page 3-14).
- Function of handlebar switch.
- Operation of front brake lever (page 3-13).

(1) THROTTLE HOUSING

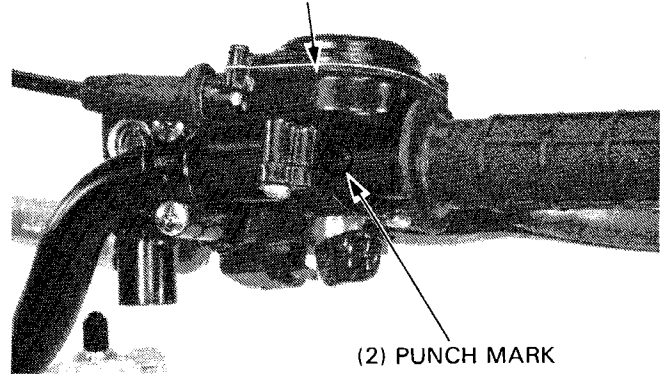

THROTTLE HOUSING

DISASSEMBLY

Remove the three throttle housing cover screws and the cover. Remove the gasket.

(1) THROTTLE HOUSING COVER

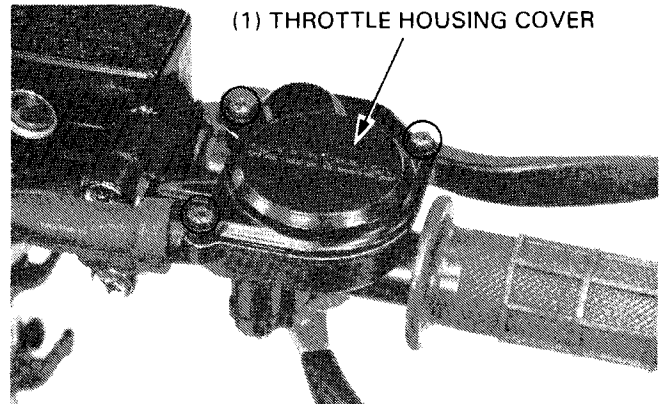

Loosen the throttle cable adjuster.

Bend down the lock washer tab and remove the nut and lock washer.

Disconnect the throttle cable from the throttle arm.

Remove the throttle arm, spring and throttle lever from the throttle housing.

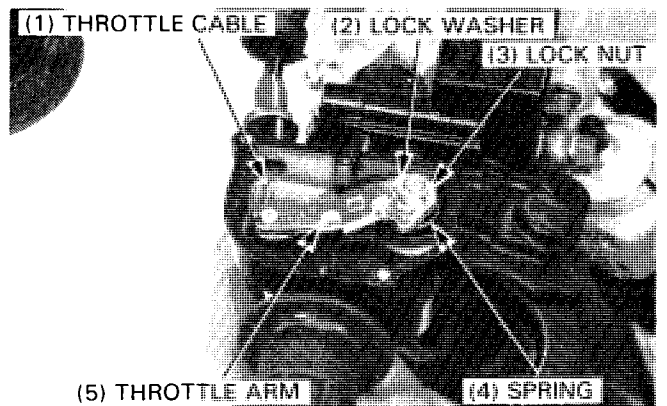

ASSEMBLY

Connect the throttle cable to the throttle arm.

Install the throttle lever and spring in the housing.

Install the throttle arm onto the throttle lever by aligning their flats.

Hook the spring end to the throttle arm using a wire or small hook.

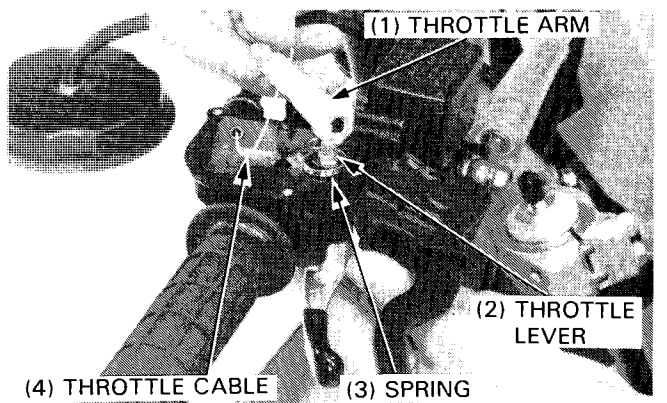

FRONT WHEEL/SUSPENSION/STEERING

Install a new lock washer and nut.

Bend up the lock washer tab against the nut.

Install a new gasket and the throttle housing cover using the three screws.

Adjust throttle lever free play (page 3-6).

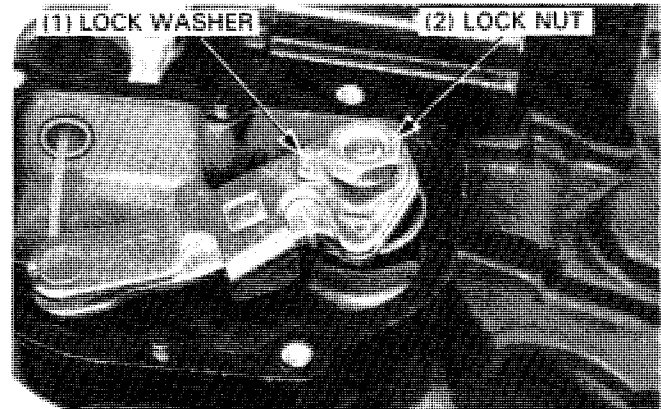

FRONT WHEEL

REMOVAL

Remove the caliper bracket mount bolts.

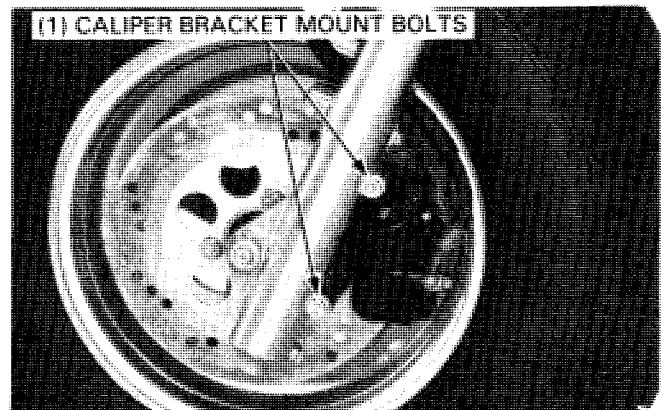

Loosen the axle holder nut, axle and wheel nuts.

Raise the front wheel off the ground by placing a block or safety stand under the skid plate.

Remove the wheel nuts and slide the wheel away from the brake disc.

Remove the caliper bracket with the caliper from the fork leg.

NOTE

- Place a small wooden wedge between the brake pads to keep them from being forced out at the caliper.
- Do not loosen the brake hose. Whenever the brake hose is loosened, it is necessary to bleed air from the brake. Refer to page 14-3 for bleeding procedures.

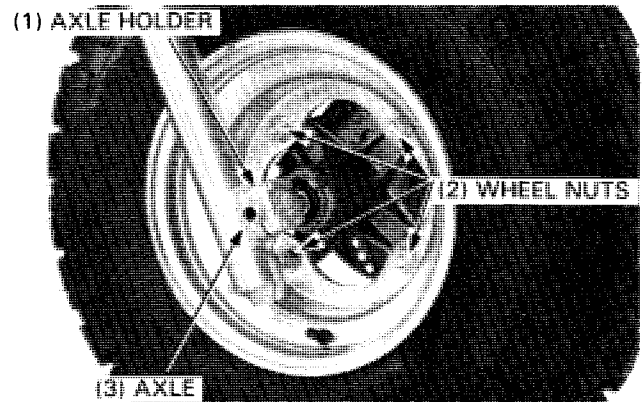

Remove the axle and the front wheel.

INSPECTION

● FRONT AXLE

Set the axle in V-blocks, rotate and measure the runout.

SERVICE LIMIT: 0.5 mm (0.02 in)

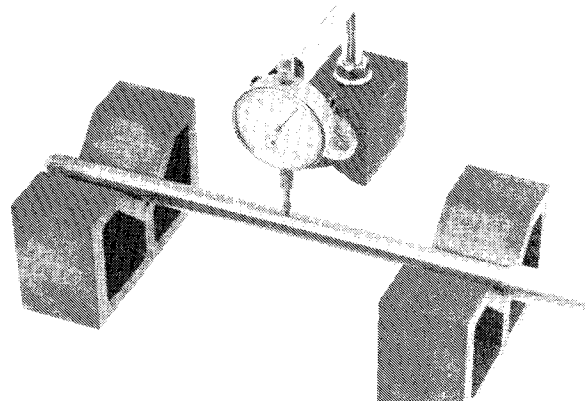

● WHEEL BEARING

Turn the inner race of each bearing with your finger. The bearings should turn smoothly and quietly. Also check that the bearing outer race fits tightly in the hub.

NOTE

- Replace wheel bearings in pairs.

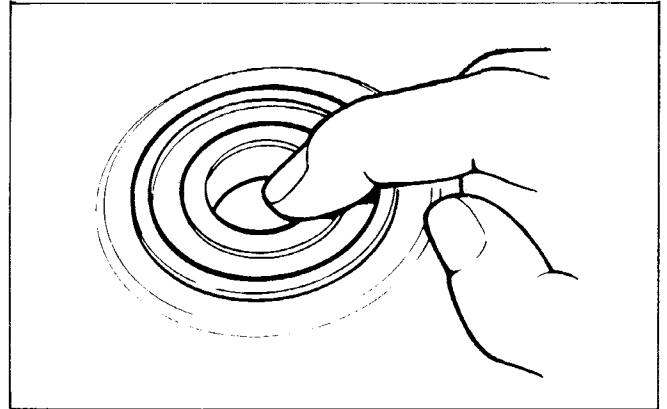

WHEEL BEARING REPLACEMENT

Remove the side collars and dust seals from the wheel hub.

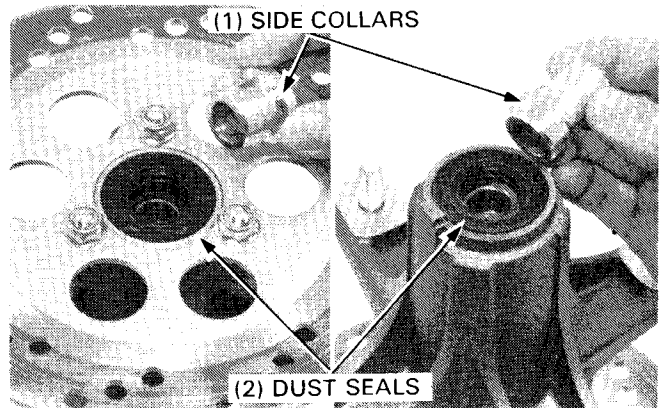

Remove the front brake disc from the wheel hub.

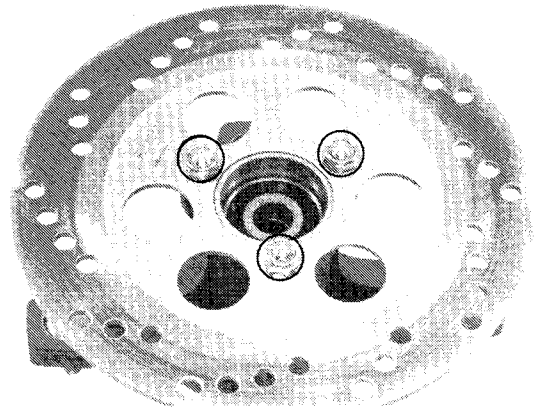

Remove the wheel bearings with a bearing remover.

NOTE

- Never reinstall old bearings; once the bearings have been removed, they must be replaced with new ones.

TOOLS:

- (1) BEARING REMOVER EXPANDER
07746-0050100 or commercially available in U.S.A.
- (2) BEARING REMOVER COLLET, 15 mm
07746-0050400 or commercially available in U.S.A.

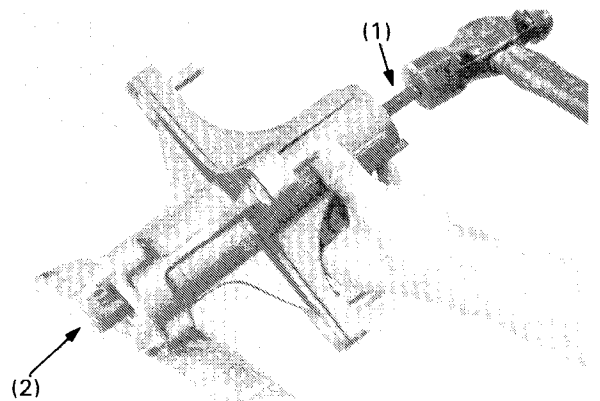

FRONT WHEEL/SUSPENSION/STEERING

Pack the new bearings with grease.

First, drive a new left bearing in squarely until it is fully seated, install the spacer, then drive a new right bearing in squarely.

TOOLS:

DRIVER 07749-0010000
ATTACHMENT, 42 x 47 mm 07746-0010300
PILOT, 15 mm 07746-0040300

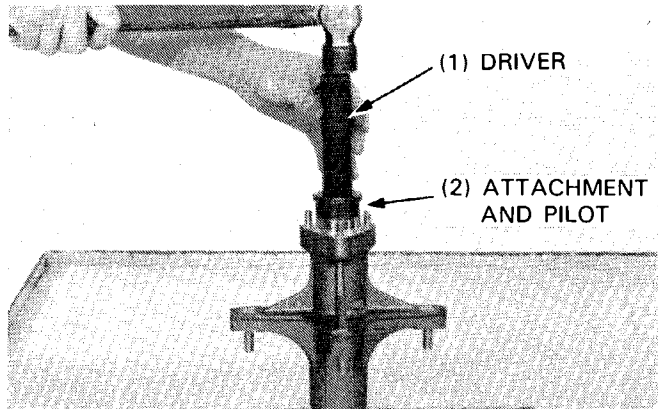

Install the front brake disc with the "DRIVE" mark facing out (arrow points the normal rotating direction).

Tighten the disc mount nuts ('85) or bolts (After '85).

TORQUE:

'85: 20-30 N·m (2.0-3.0 kg-m, 15-22 ft-lb)
After '85: 35-40 N·m (3.5-4.0 kg-m, 25-29 ft-lb)

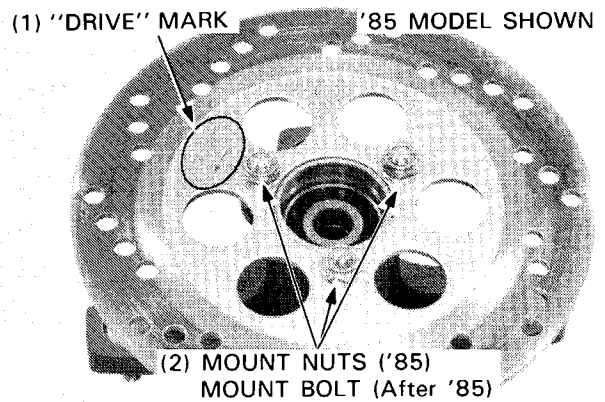

Apply grease to the dust seal lips and install the seals into the hub.

Install the side collars into the hub.

NOTE

- The longer collar is for the right side.

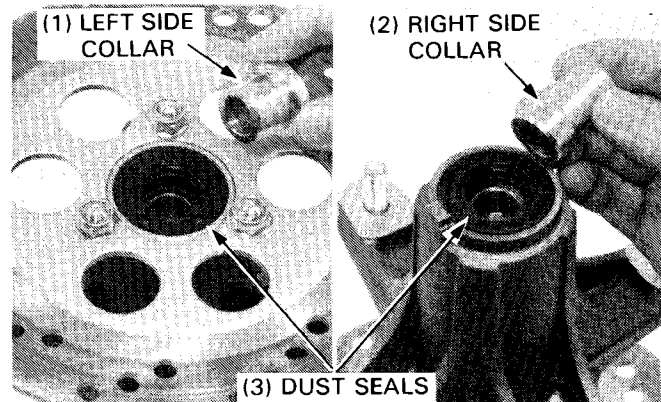

TIRE REPAIR

NOTE

- Use the manufacturer's instructions for the tire repair kit you are using.
- If your kit does not have instructions use the procedures provided here.

Check the tire for puncturing objects. Chalk mark the punctured area and remove the puncturing object.

Inspect and measure the injury. Tire repairs for injuries larger than 15 mm (5/8 in) should be a section repair.

Section repairs should be done by a professional tire repair shop.

If the injury is smaller than 15 mm (5/8 in), proceed with the repair as described here.

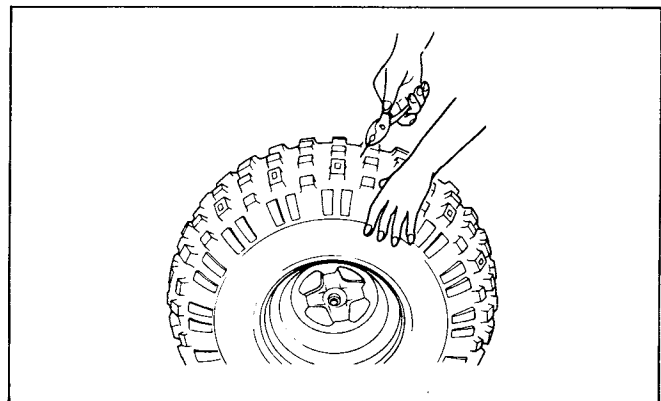

Install a rubber plug into the injury as follows:

Apply cement to a plug inserting needle and work the needle into the injury to clean and lubricate it. Do this three times. Do not let the cement dry.

Insert and center a rubber plug through the eye of the inserting needle.

Apply cement to the rubber plug.

Push the inserting needle with plug into the injury until the plug is slightly above the tire. Twist the needle and remove it from the tire, the plug will stay in the tire.

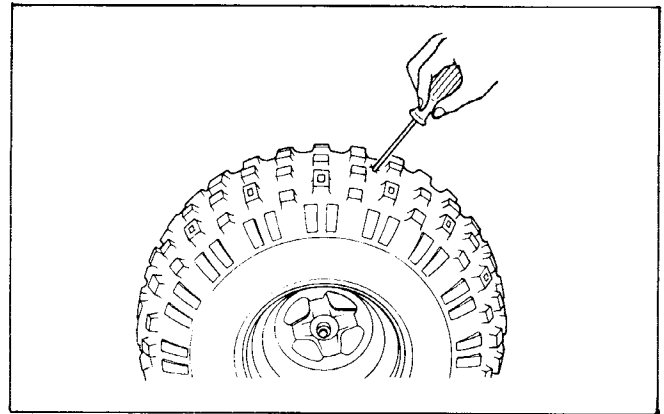

NOTE

- Be careful not to push the plug all the way into the tire to prevent it from falling inside.

Trim the plug to 6 mm (1/4 in) above the tire surface.

Repeat the above procedure if the puncture is large. Do not use more than two plugs per injury.

Allow the repair to dry. Drying time will vary with air temperature. Refer to the tire repair kit manufacturer's recommendations.

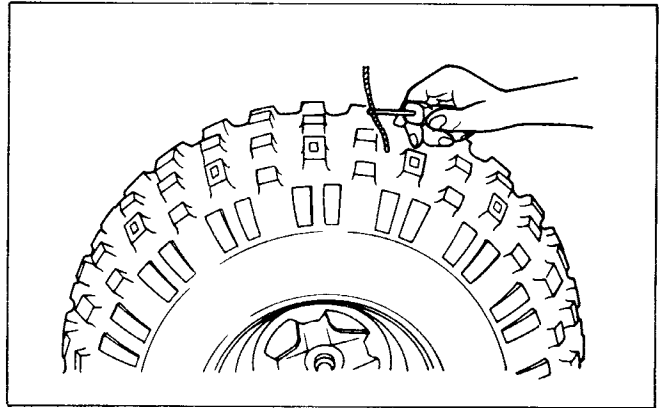

Inflate the tire and test the seal by dabbing a small amount of cement around the plug. Escaping air will cause a bubble in the cement. If there is leakage, remove the tire (page 11-10) and apply a cold patch to the inside of the tire as described.

If a plug has been inserted, trim it even with the inner tire surface.

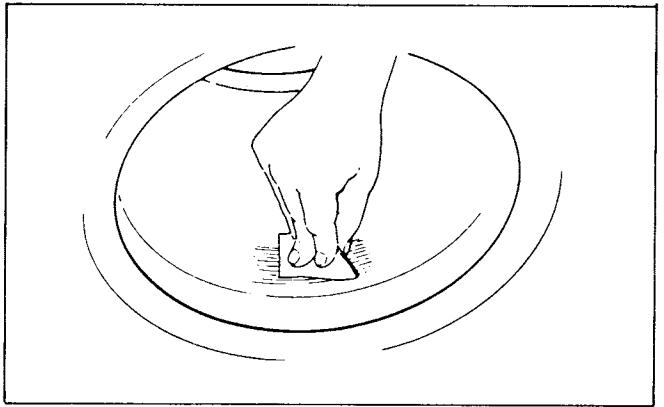

Temporarily place a rubber patch that is at least twice the size of the puncture over the injury. Make a mark around the patch, slightly larger than the patch itself. Remove the patch.

Roughen the area marked inside the tire with a tire buffer or a wire brush. Clean the rubber dust from the buffed area.

Apply cement over the area marked and allow it to dry. Remove the lining from the patch and center it over the injury. Press the patch against the injury using a special roller.

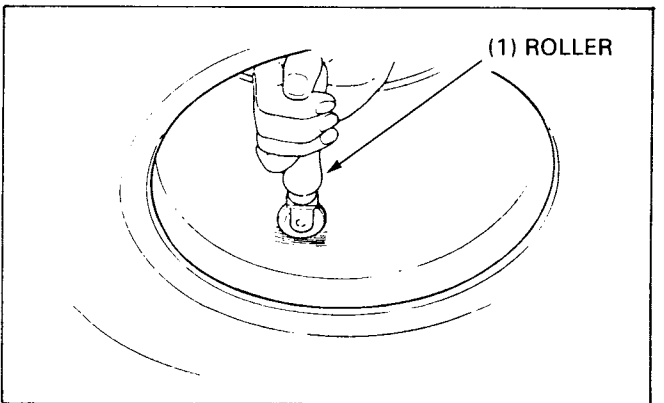

NOTE

- Allow cement to dry until tacky before applying patch.
- Do not touch the cement with dirty or greasy hands.

FRONT WHEEL/SUSPENSION/STEERING

TIRE REMOVAL

NOTE

- This service requires the Universal Bead Breaker (GN—AH—958—BB1) available in U.S.A. only.

Remove the core from the valve stem.

CAUTION

- Use of the Bead Breaker tool is required for tire removal.
- Do not damage the bead seating area of the rim.
- Use a Coats 220 Tire Changer or equivalent to remove the tire from the rim. If a tire changer is not available, rim protectors and tire irons may be used.

Install the proper size blade onto the breaker arm assembly.

Short blade—7"/8" rims.
Long blade—9"/11" rims.

CAUTION

- Use of an improper size blade may result in damage to the rim, tire or blade.

Place the proper size adapter onto the threaded shaft and then put the wheel over the threaded shaft and adapter.

Apply water to the bead area, pressing down on the tire sidewall/bead area in several places, to allow the water to run into and around the bead. Also apply water to the area where the breaker arm will contact the sidewall of the tire.

WARNING

- Use only water as a lubricant when removing or mounting tires. Soap or some mounting lubricants may leave a slippery residue which can cause the tire to shift on the rim and lose air pressure during riding.

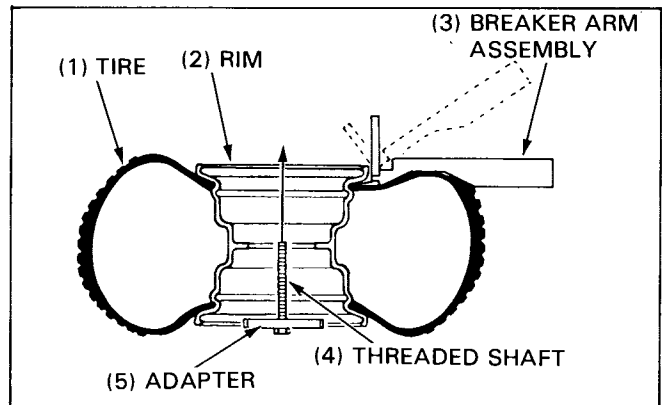
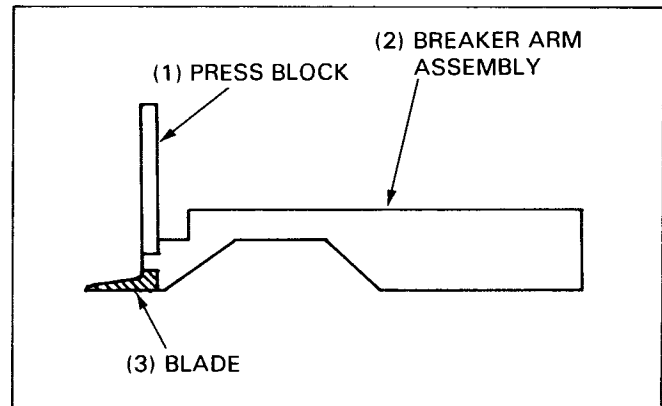

While holding the breaker arm assembly at an approximate 45° position, insert the blade of the breaker arm between the tire and rim. Push the breaker arm inward and downward until it is in the horizontal position with its press block in contact with the rim.

NOTE

- It may be necessary to tap the breaker arm with a brass hammer to install it the last 3 mm. While doing so, be sure to hold the arm down in the horizontal position.

With the breaker arm in the horizontal position, place the breaker press head assembly over the breaker arm press block. Make sure the press head bolt is backed out all the way and then position the nylon buttons on the press head against the inside edge of the rim.

Insert the threaded shaft through the appropriate hole in the breaker press head assembly and then tighten the lever nut until both ends of the breaker press head assembly are in firm contact with the rim.

NOTE

- Insert bolts through the holes in the rim hub mounting tabs and the adapter to position the adapter properly.

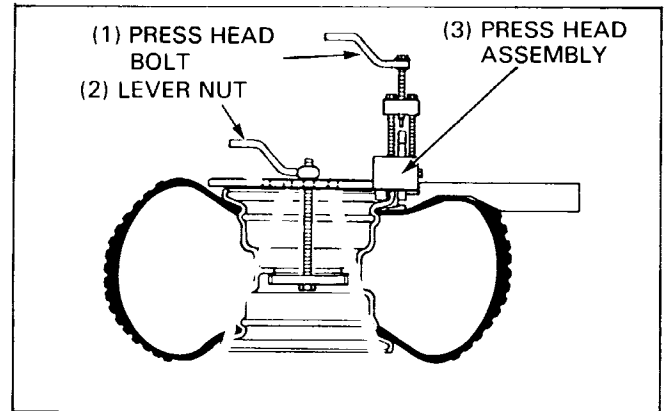

Tighten the press head bolt until the reference mark on the press block is aligned with the top edge of the press head.

If the rest of the bead cannot be pushed down into the center of the rim by hand, loosen the press head bolt and the lever nut. Rotate the breaker arm assembly and breaker press head assembly 1/8 to 1/4 the circumference of the rim. Tighten the lever nut and then tighten the press head bolt as described. Repeat this procedure as necessary until the remainder of the bead can be pushed down into the center of the rim.

Assemble the Universal Bead Breaker on the other side of the wheel and break the bead following the same procedures.

Remove the tire from the rim using a tire changer machine or tire irons and rim protectors.

Remove the front tire from the valve stem side and the rear tires from the side opposite the valve stem.

TIRE REMOVAL (EXCEPT U.S.A)

NOTE

- This service requires the Tire Bead Breaker Set (07772-0050000) not available in U.S.A.

CAUTION

- Do not apply water, soap water, oil etc. to the tire, rim and tool when removing the tire. The tool breaker arm may slip off the tire and the bead can not be broken off the tire.
- Do not damage the bead seating area of the rim.
- Follow the breaker manufacturer's instructions.

Insert the narrow end (A side) of the breaker arm between the tire and the rim.

Position the breaker arm compressor onto the rim center as shown.

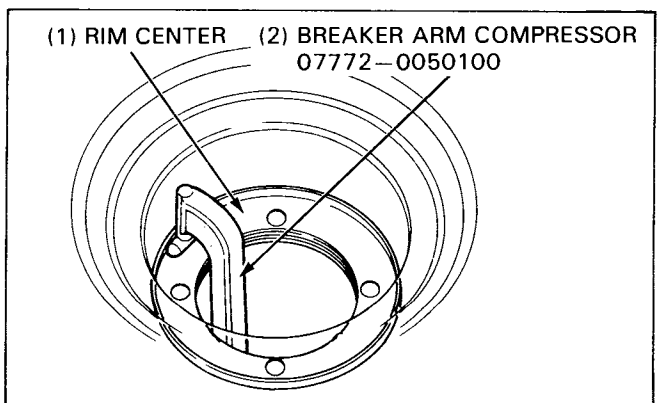
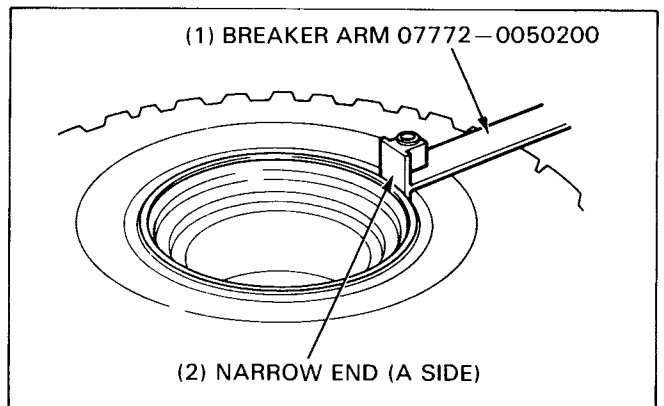
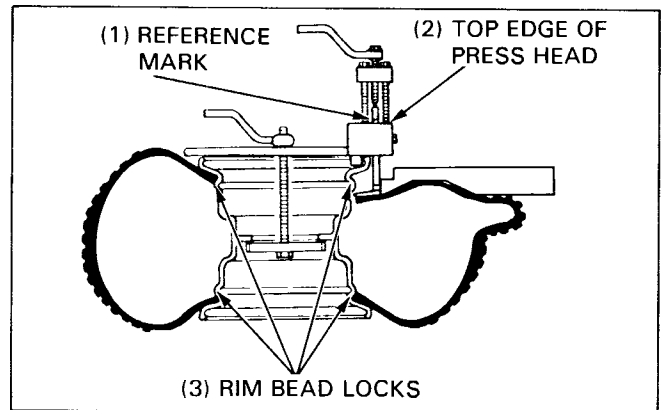

FRONT WHEEL/SUSPENSION/STEERING

Keep the breaker arm horizontal and align the end of the compressor bolt with the arm hole.

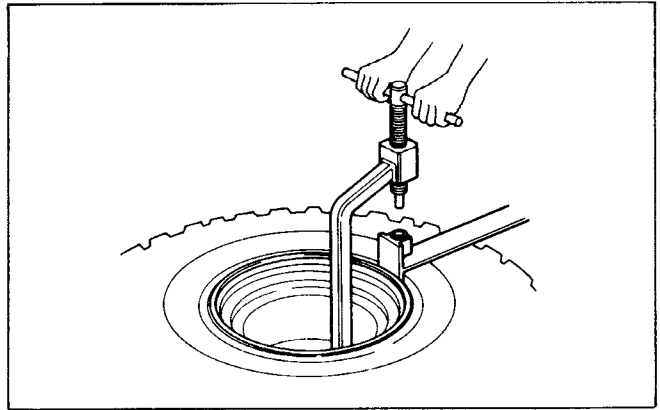

Screw in the breaker arm compressor bolt to break the bead from the tire.

If the rest of the bead cannot be pushed down into the center of the rim, remove and reposition the compressor and arm 1/8 to 1/4 the circumference of the rim. Tighten the compressor bolt to break the bead. Repeat this procedure as necessary until the remainder of the bead can be pushed down into the center of the rim.

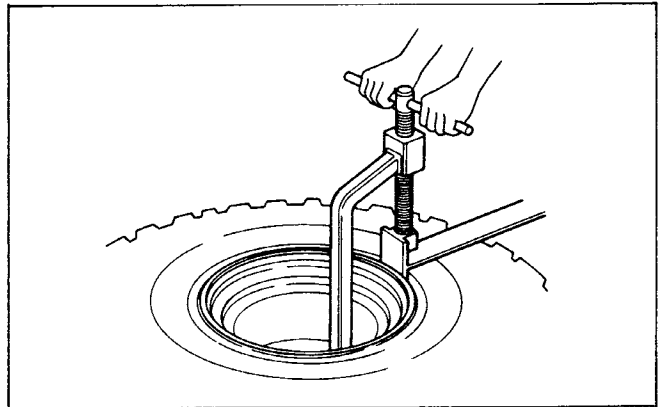

If the bead breaking is difficult with the narrow end (A side) of the breaker arm, use the wide end (B side) of the arm and repeat the procedure above.

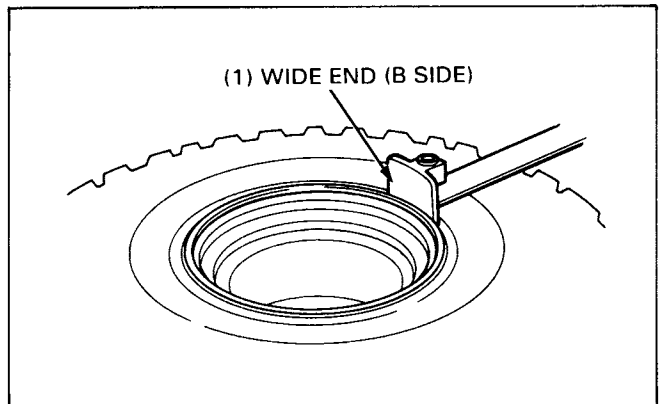

TIRE ASSEMBLY

Clean the rim bead seat and flanges.

Apply clean water to the rim flanges, bead seat and base.
Install the tire on the rim.

WARNING

- *Use only water as a lubricant when removing or mounting tires. Soap or some mounting lubricants may leave a slippery residue which can cause the tire to shift on the rim and lose air pressure during riding.*

Inflate the tire to seat the tire bead.

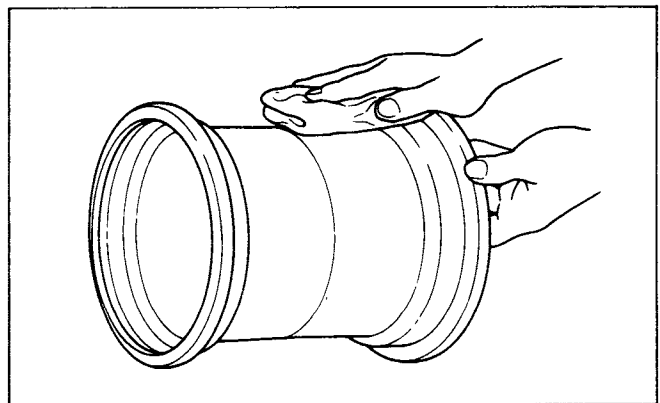

CAUTION

- *Do not inflate the tire with more than 1.4 kg/cm² (20 psi) of air.*

If the tire does not seat on the rim with 1.4 kg/cm² (20 psi) of air pressure, release the air from the tire and apply water to the tire bead and bead seating surface of the rim.

Then, inflate the tire with air again.

Deflate the tire. Wait 1 hour, install the valve core in the valve stem and inflate the tire to the specified pressure.

	Recommended pressure	Standard tire circumference
Front	4.0 psi (28 kPa, 0.28 kg/cm ²)	1,901 mm (74.8 in)
Rear	3.0 psi (21 kPa, 0.21 kg/cm ²)	1,734 mm (68.3 in)

NOTE

- The rear tires must have the same circumference for proper handling.

Check for air leaks and install the valve cap.

FRONT WHEEL INSTALLATION

Install the front wheel and hub.

If the axle holder has been removed, loosely install the holder with the "UP" mark facing up.

Insert the axle into the fork slider leg and hub and loosely tighten the axle.

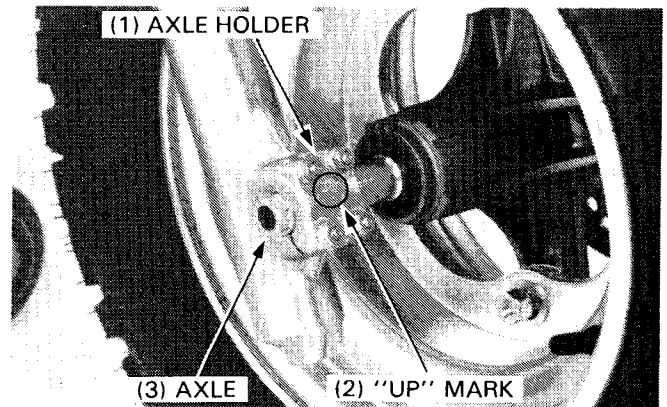

Install the front brake caliper over the disc and on the fork slider being careful not to damage the pads.

Temporarily install the brake caliper bracket mount bolts.

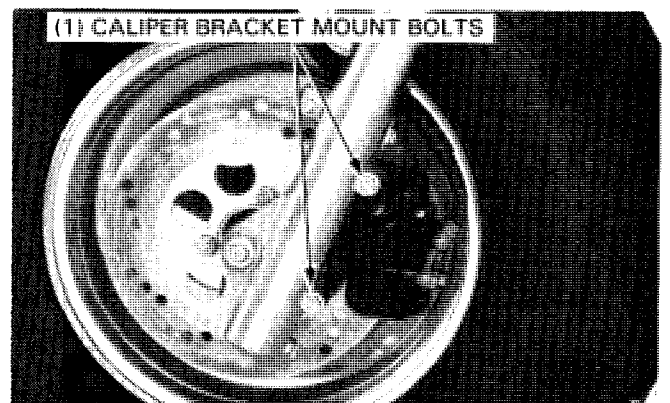

FRONT WHEEL/SUSPENSION/STEERING

Install the wheel nuts with the tapered side facing in.
Lower the front wheel on the ground and tighten the wheel nuts.

TORQUE: 60–70 N·m (6.0–7.0 kg-m, 43--51 ft-lb)

Tighten the axle.

TORQUE: 70–110 N·m (7.0–11.0 kg-m, 51–80 ft-lb)

Tighten the upper axle holder nuts first, then tighten the lower nuts.

TORQUE: 10–14 N·m (1.0–1.4 kg-m, 7–10 ft-lb)

Tighten the caliper bracket mount bolts.

TORQUE: 20–30 N·m (2.0–3.0 kg-m, 15--22 ft-lb)

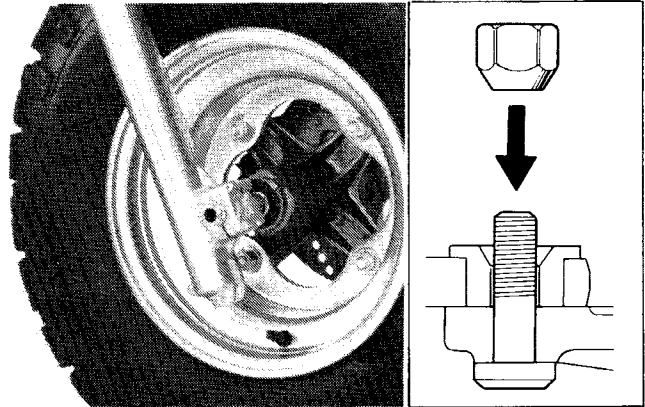

FRONT FORK

REMOVAL

Remove the front wheel (page 11-6).

Remove the front brake hose clamps from the left fork slider.

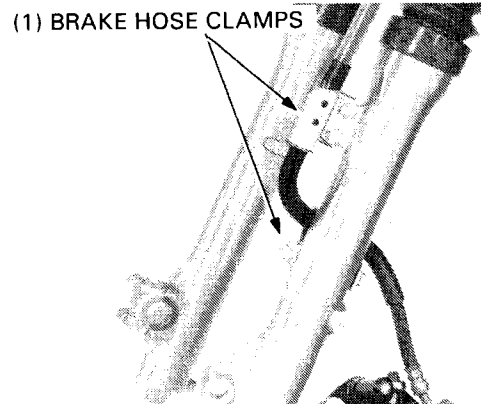

Remove the headlight case retaining bands and loosen the fork pinch bolts.

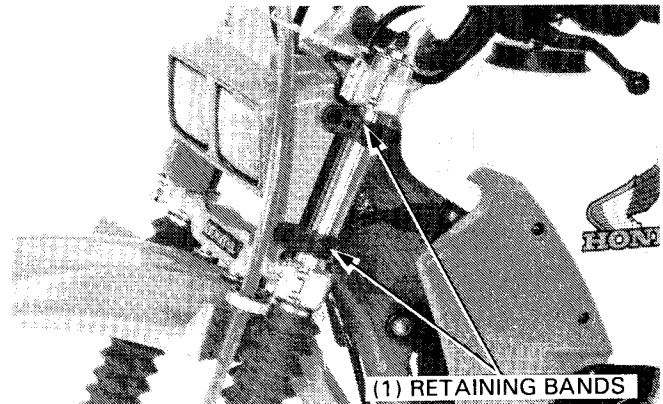

Loosen the fork boot band and slide the boot down.

Pull the fork tube out of the bridge and steering stem.

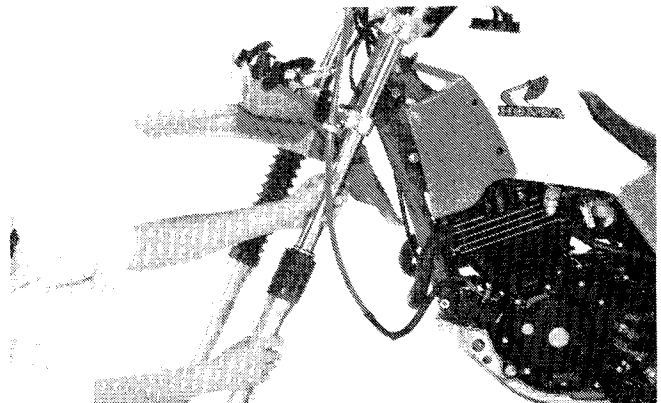

DISASSEMBLY

Release air pressure and remove the fork boot.

Hold the fork tube in a vise with soft jaws or a shop towel and remove the fork tube cap.

CAUTION

- Do not damage the fork tube sliding surface.

WARNING

- The fork cap is under spring pressure. Use care when removing the cap to keep it from causing injury.

Remove the spring seat and fork springs.

Drain the fork oil by pumping the fork up and down several times.

(1) FORK TUBE CAP

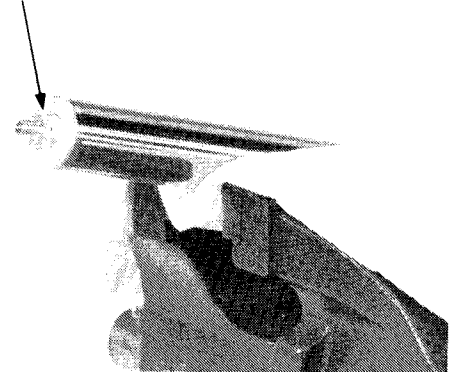

(1) LOWER SPRING

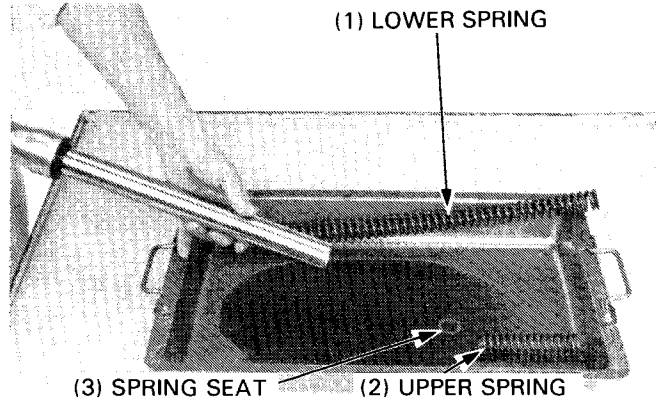

Hold the fork slider in a vise with soft jaws or shop towel.

CAUTION

- Do not overtighten the slider in the vise. Overtightening will damage the slider.

Remove the socket bolt with a hex wrench.

NOTE

- Temporarily install the springs and fork tube cap if difficulty is encountered in removing the socket bolt.

(1) HEX. WRENCH, 6 mm
07917-3230000 OR EQUIVALENT
COMMERCIALY AVAILABLE IN U.S.A.

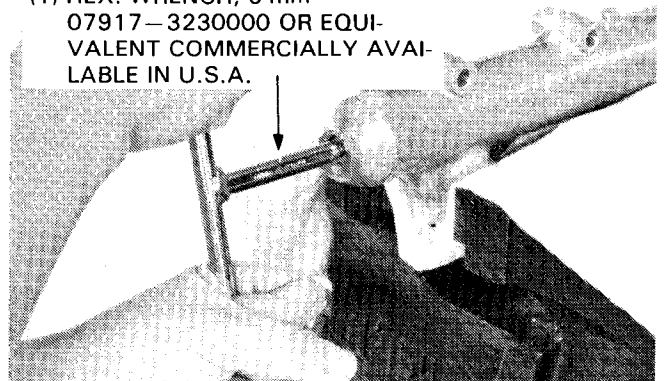

Remove the fork piston and rebound spring.

Remove the dust seal.

(1) DUST SEAL

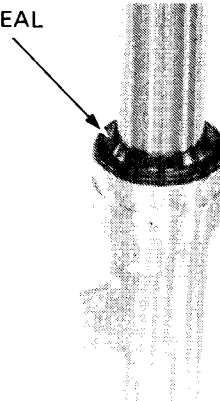

FRONT WHEEL/SUSPENSION/STEERING

Remove the snap ring.

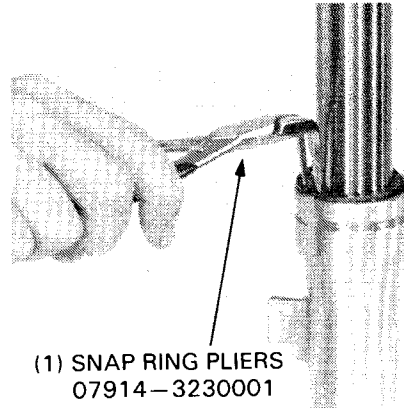

Pull the fork tube out until resistance from the slider bushing is felt. Then move it in and out, tapping the bushing lightly until the fork tube separates from the slider. The slider bushing will be forced out by the fork tube bushing.

Remove the oil lock piece.

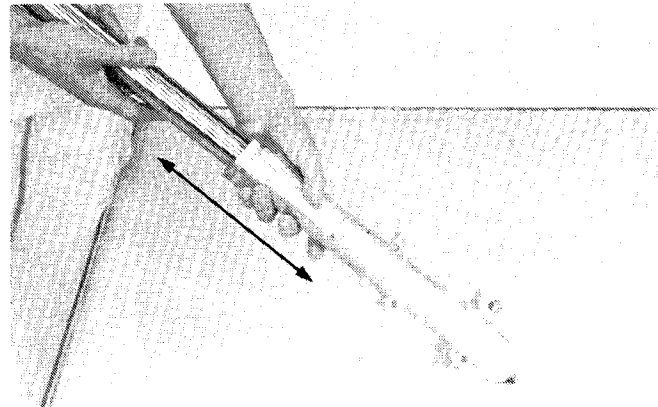

Remove the oil seal, back-up ring and slider bushing from the fork tube.

NOTE

- Do not remove the fork tube bushing unless it is necessary to replace it with new one.

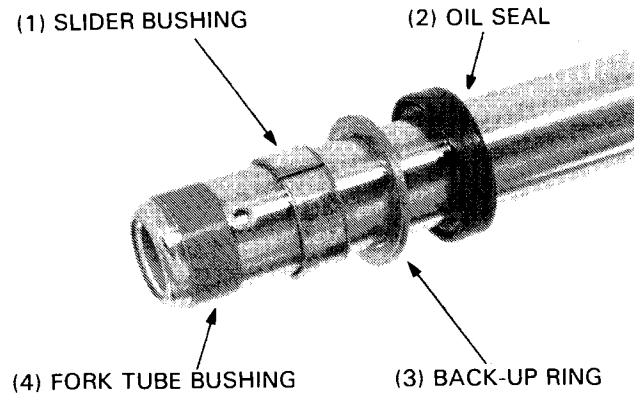

INSPECTION

● FORK SPRING

Measure the fork springs' free length.

SERVICE LIMITS:

UPPER FORK SPRING: 109.4 mm (4.31 in)

LOWER FORK SPRING: 483.4 mm (19.03 in)

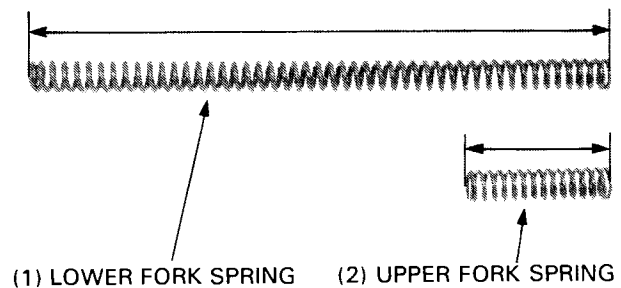

FRONT WHEEL/SUSPENSION/STEERING

● FORK TUBE/SLIDER/PISTON

Check the fork tube, slider and piston for scoring, scratches, or excessive or abnormal wear.

Replace any components which are worn or damaged.

Check the fork piston ring for wear or damage.

Check the rebound spring for fatigue or damage.

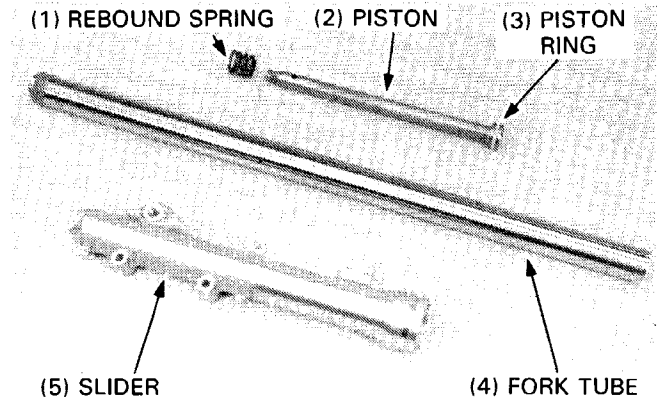

Place the fork tube in V blocks and read the runout.

SERVICE LIMIT: 0.2 mm (0.008 in)

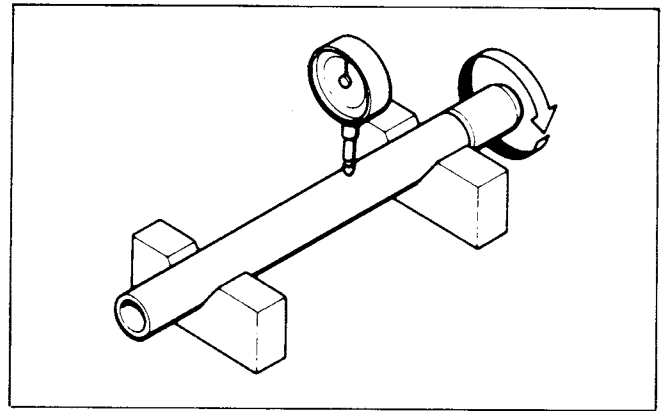

● BUSHING

Visually inspect the slider and fork tube bushing.

Replace the bushing if there is excessive scoring or scratching, or if the teflon is worn so that the copper surface appears on more than 3/4 of the entire surface.

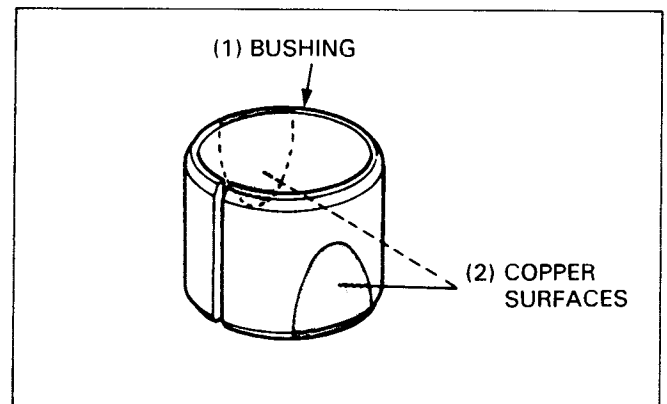

ASSEMBLY

NOTE

- Wash all removed parts in solvent and wipe them off thoroughly before assembly.

FRONT WHEEL/SUSPENSION/STEERING

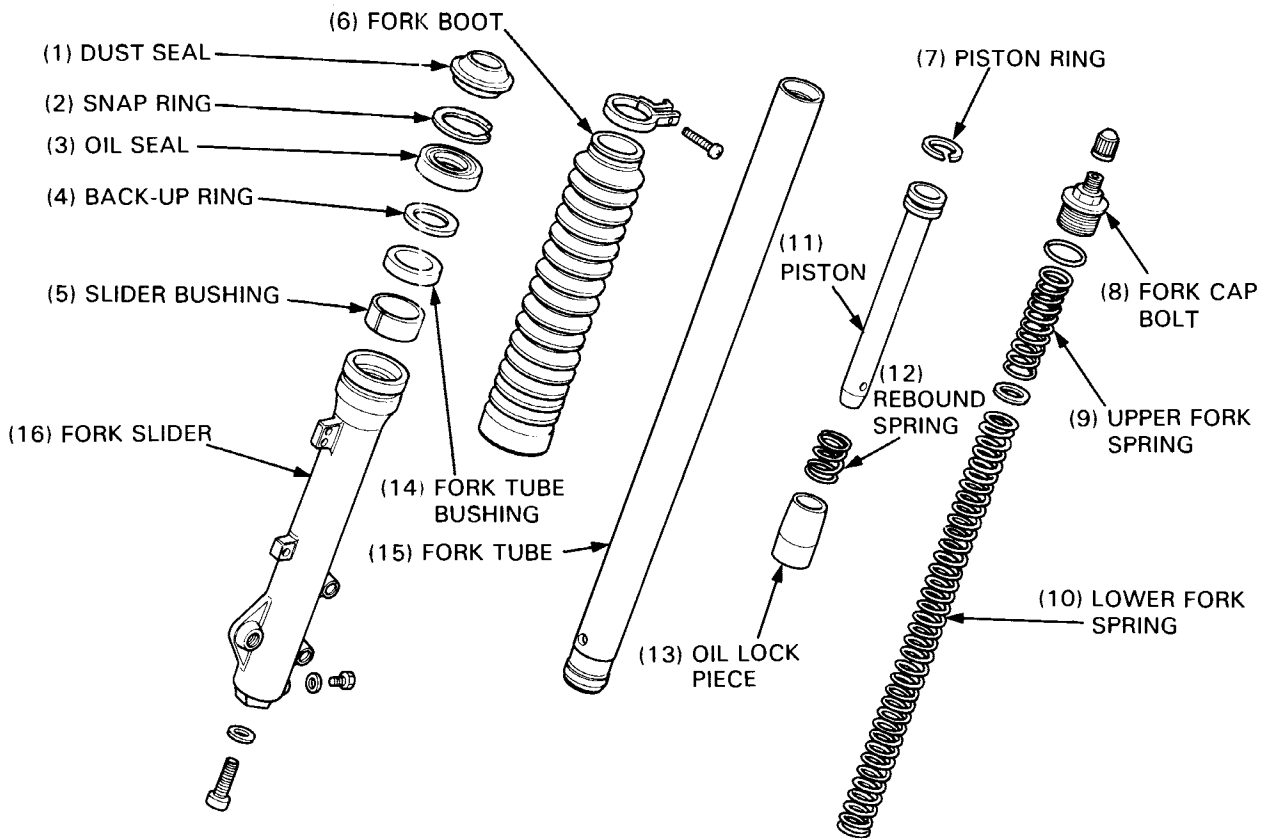

Install the piston ring on the piston.

Install the fork tube bushing if a new one is being installed.

Install the rebound spring and piston into the fork tube.

Place the oil lock piece on the end of the piston and insert the fork tube into the slider.

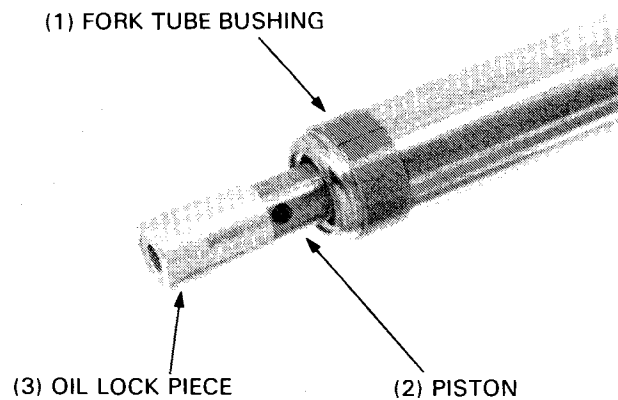

Place the fork slider in a vise with soft jaws or a shop towel.

Clean the socket bolt threads and apply thread lock agent to the threads. Screw the socket bolt into the piston and tighten it with a 6 mm hex wrench.

NOTE

- Temporarily install the fork springs and fork tube cap to tighten the socket bolt.

TORQUE: 15–20 N·m (1.5–2.0 kg·m, 11–14 ft·lb)

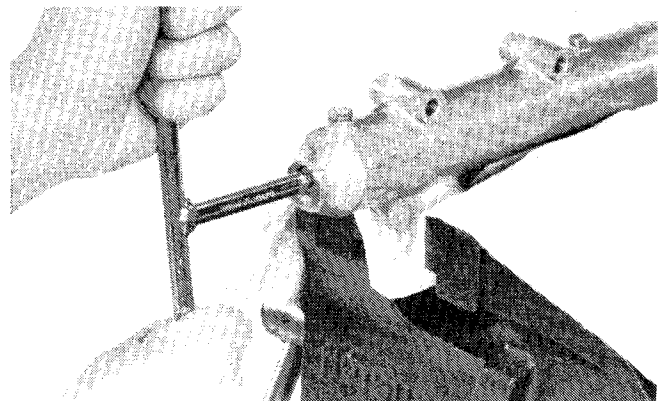

Place the slider bushing over the fork tube and rest it on the slider. Put the back-up ring and an old bushing or equivalent tool on the top.

Drive the bushing into place with the fork seal driver and remove the old bushing or equivalent tool.

Wrap tape around the top of the fork tube to prevent damage to the new oil seal.

Coat a new oil seal with ATF and install it with the seal markings facing up. Drive the seal in, until the snap ring groove is visible, with the fork seal driver.

TOOLS:

- (1) FORK SEAL DRIVER 07947-KA50100
- (2) FORK SEAL DRIVER ATTACHMENT 07947-KL40100 or 07947-3710101

Install the snap ring and dust seal.

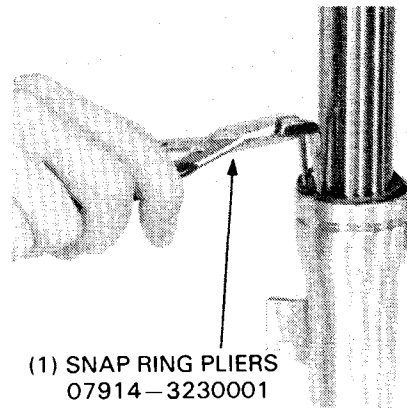
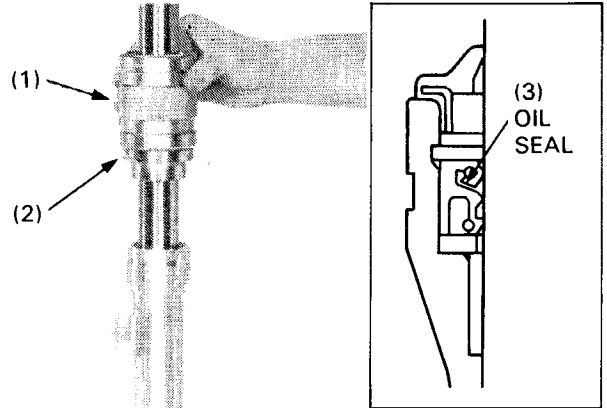

Fill the fork with ATF.

CAPACITY: 290 cc (9.8 US oz, 10.2 Imp oz)

Pump the fork several times.

Compress the fork and measure the ATF level from the top of the tube after the level stabilizes.

SPECIFIED LEVEL: 215 mm (8.5 in)

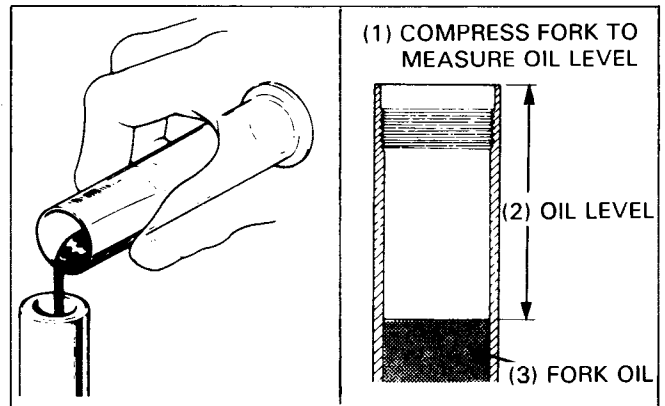

Wipe oil off the spring thoroughly using a clean cloth.

Install the lower fork spring with the tapered end facing down. Install the spring seat and the upper fork spring.

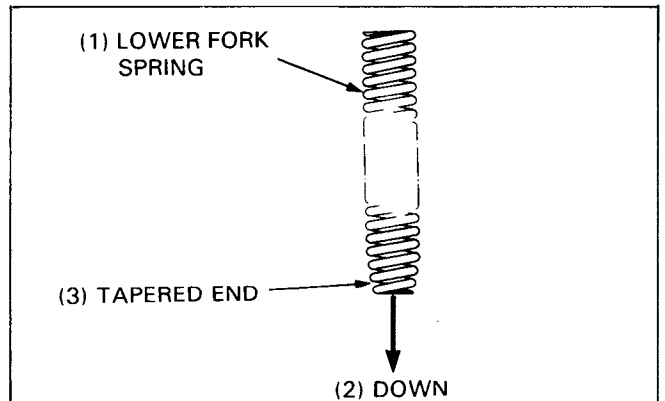

FRONT WHEEL/SUSPENSION/STEERING

Hold the fork tube in a vise with soft jaws or a shop towel, and install and tighten the fork tube cap.

TORQUE: 15–30 N·m (1.5–3.0 kg-m, 11–22 ft-lb)

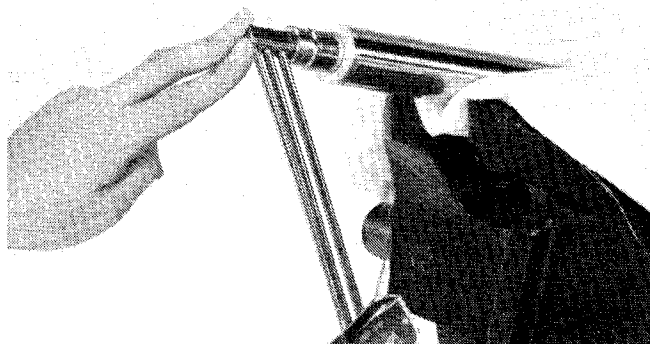

Install the fork boot on the fork tube and slider.

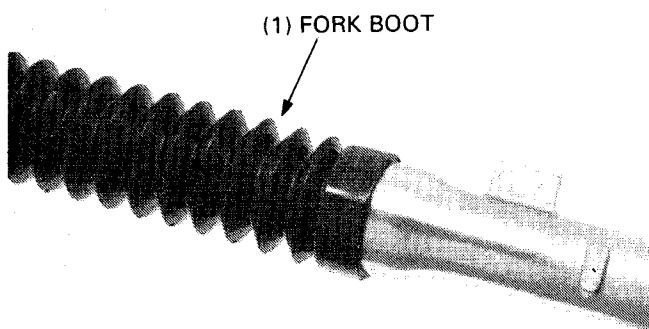

INSTALLATION

Install the front fork into the steering stem and fork bridge, and align the groove of the fork tube with the top of the fork bridge.

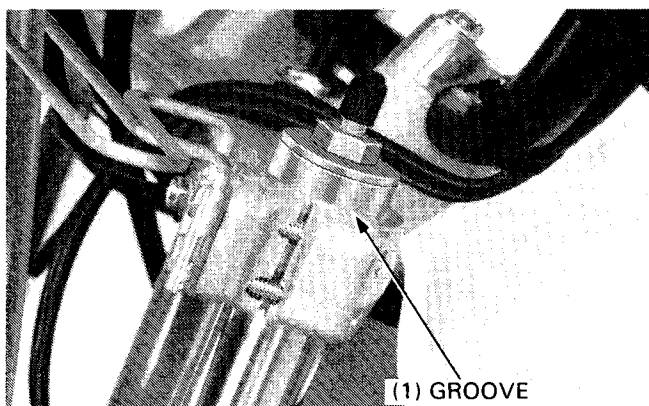

Tighten the fork top and bottom pinch bolts.

TORQUE: 18–25 N·m (1.8–2.5 kg-m, 13–18 ft-lb)

Slide the fork boot up to the steering stem and tighten the boot band.

TORQUE: 0.6–1.2 N·m (0.06–0.12 kg-m, 0.4–0.9 ft-lb)

Install the headlight case retaining bands.

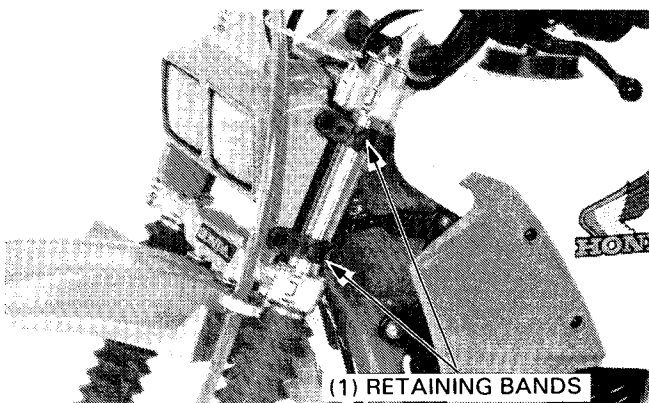

Install the front brake hose clamps onto the left fork slider.

Install the front wheel (page 11-13).

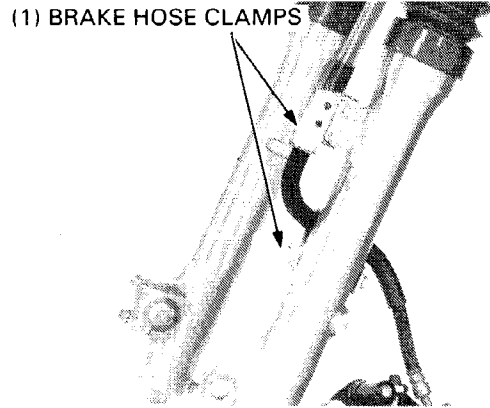

STEERING STEM

REMOVAL

Remove the following parts:

- headlight case (page 11-14)
- handlebar (page 11-3)
- front wheel (page 11-6)
- front fender.

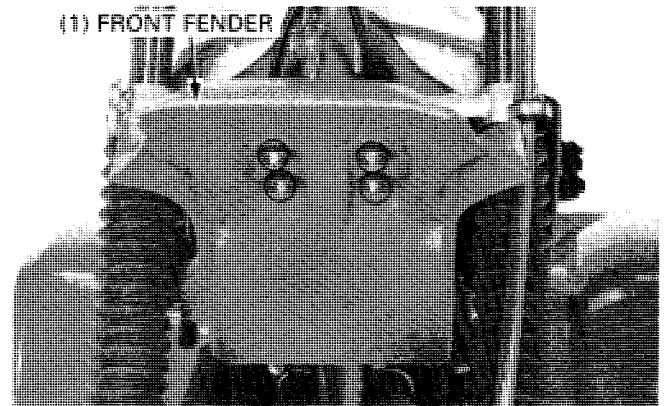

Remove the cable guide from the fork bridge.

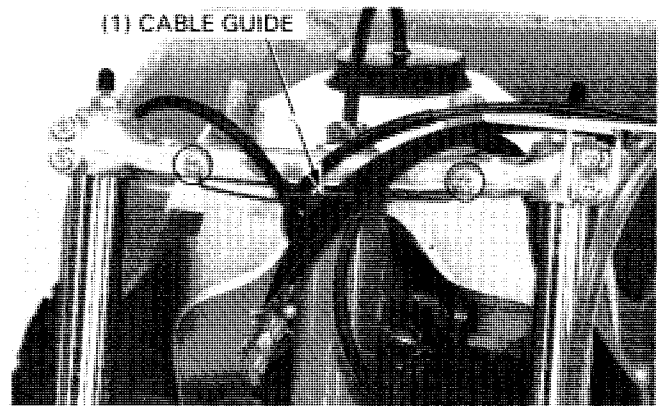

Remove the steering stem nut and washer.

Loosen the fork pinch bolts, and remove the front forks.

Remove the fork bridge.

TOOLS:

- (1) EXTENSION BAR 07716-0020500 or equivalent commercially available in U.S.A.
- (2) LOCK NUT WRENCH, 30 x 32 mm 07716-0020400 or equivalent commercially available in U.S.A.

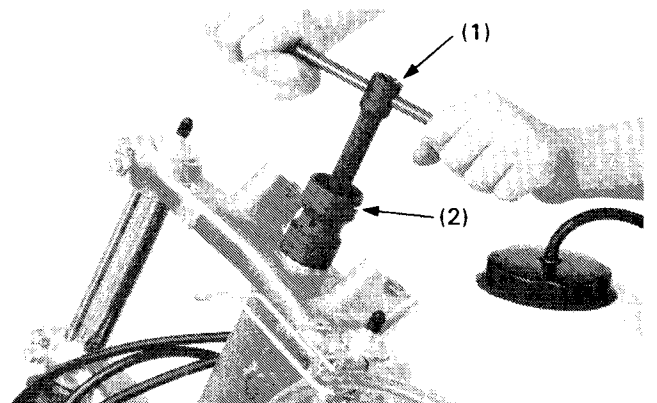

FRONT WHEEL/SUSPENSION/STEERING

Loosen the steering bearing adjustment nut.

(1) STEERING STEM SOCKET
07916-3710100

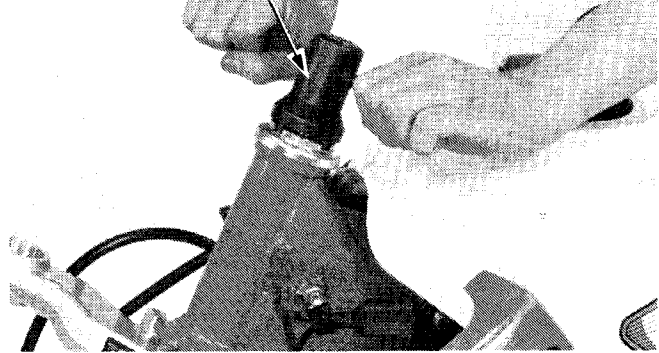

Remove the steering bearing adjustment nut, stem, upper cone race and steel balls.

NOTE

- The steel ball bearings are loose and easily dropped. Place shop towels on the floor to catch any that do drop.

Check the cone and ball races for wear or damage and replace if necessary.

NOTE

- Replace the balls and races as a set when any component is damaged.

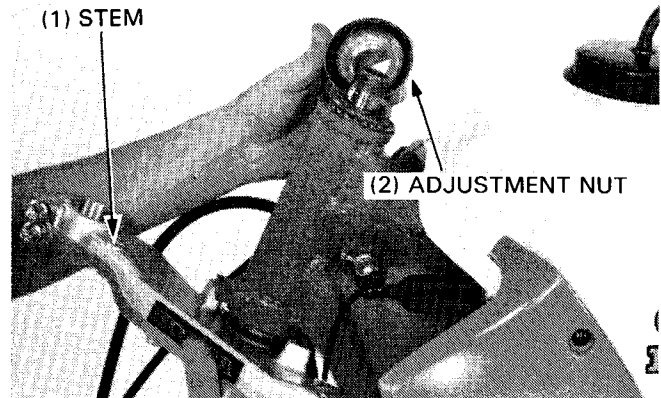

STEERING BEARING REPLACEMENT

Drive out the upper and lower ball races from the steering head pipe.

NOTE

- If the ATC has been involved in an accident, examine the area around the steering head pipe for cracks.

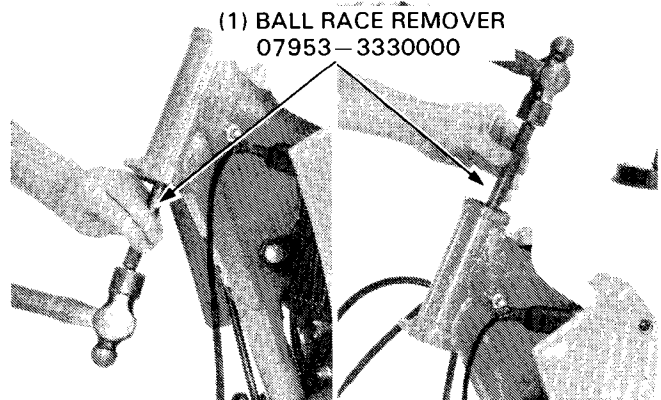

Install the stem nut onto the stem to prevent the threads from being damaged when removing the lower cone race from the stem.

Remove the race with a chisel, being careful not to damage the stem.
Remove the dust seal and washer.

After '85:

Remove the lower bearing, lower bearing outer race and dust seal.

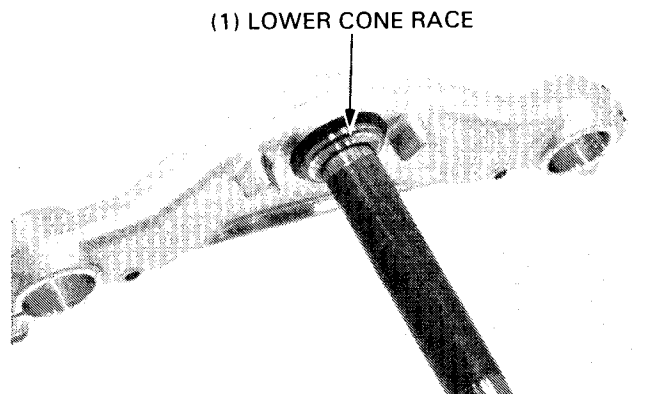

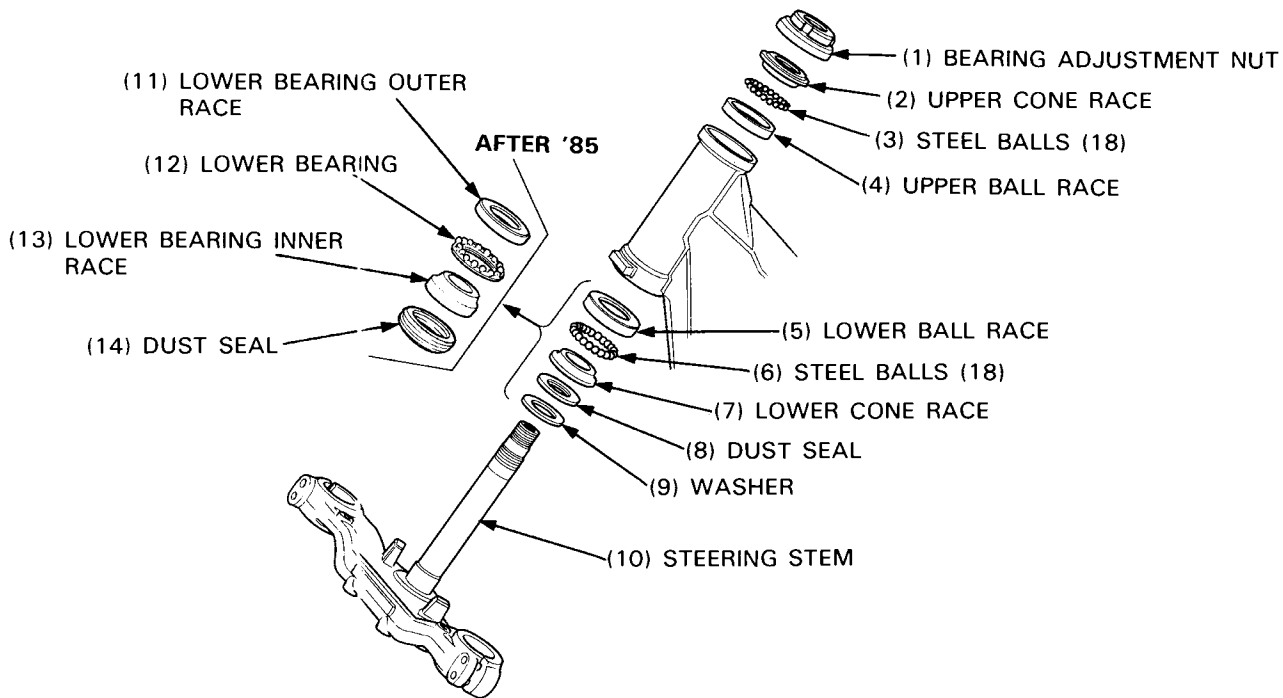

Install the washer and dust seal onto the steering stem and press a new lower cone race over the stem with the tool.

After '85:
 Install the dust seal, and press a new lower inner race and lower bearing over the stem with the tool.

TOOLS:
 STEERING STEM DRIVER 07946-4300101 or
 STEERING STEM DRIVER 07946-ME00000 and
 ATTACHMENT GN-HT-54 (U.S.A. only)

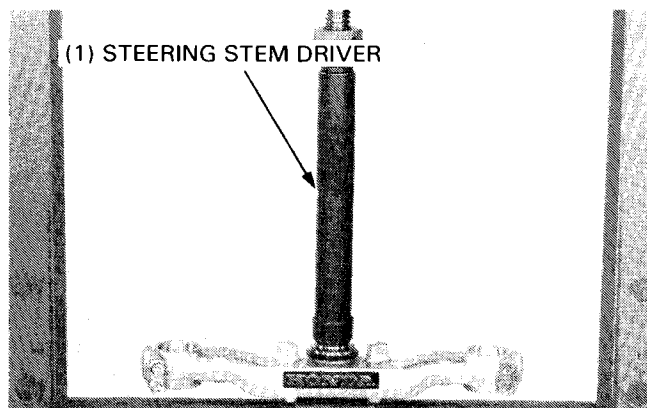

Drive new upper and lower ball races into the steering head pipe.

TOOLS:
 (1) DRIVER 07749-0010000
 (2) BALL RACE DRIVER 07946-3290000

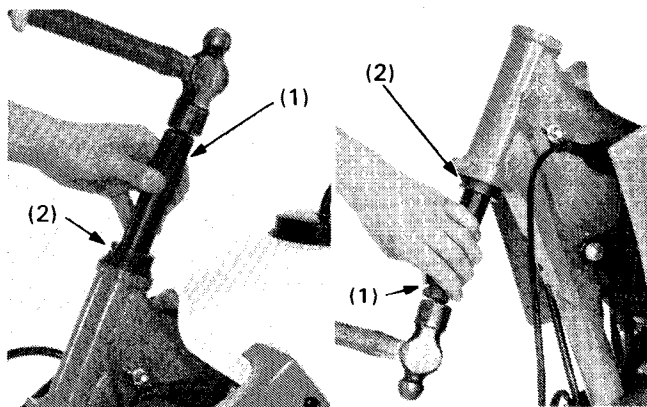

FRONT WHEEL/SUSPENSION/STEERING

INSTALLATION

Apply grease to the ball and cone races and install the steel balls in the ball races.

NOTE

- Eighteen (18) steel balls are used for both the upper and lower stem bearings.

Insert the steering stem into the steering head pipe, and install the upper cone race and steering bearing adjustment nut.

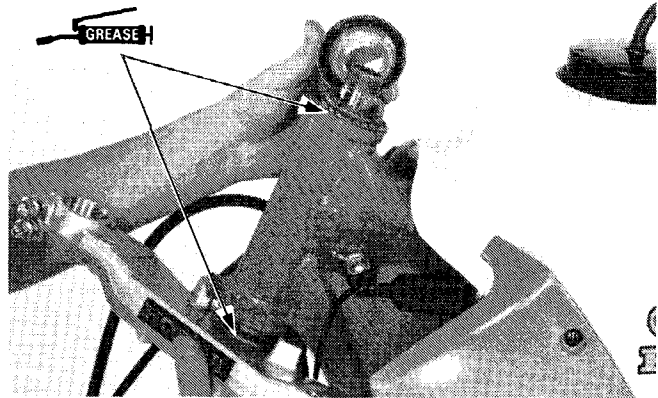

Tighten the steering bearing adjustment nut to the initial torque.

TORQUE: 25–35 N·m (2.5–3.5 kg-m, 18–25 ft-lb)

Turn the steering stem all the way to the right and left 2 or 3 times to seat the bearings, loosen the adjustment nut and re-tighten it to the final specified torque.

TORQUE: 7–8 N·m (0.7–0.8 kg-m, 5–6 ft-lb)

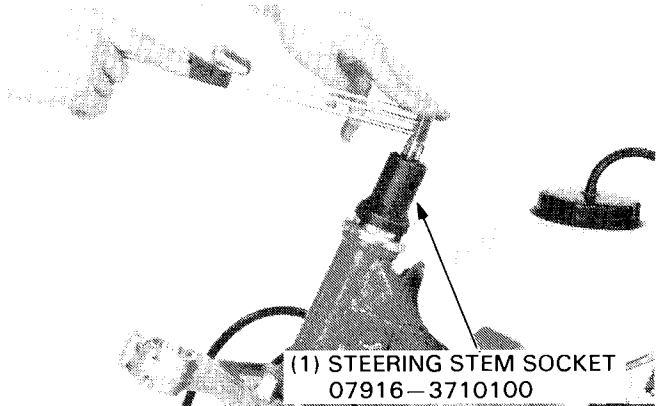

Install the fork bridge, stem nut washer and stem nut.

Temporarily install the front forks.

Tighten the steering stem nut.

TORQUE: 90–120 N·m (9.0–12.0 kg-m, 65–87 ft-lb)

TOOLS:

- (1) EXTENSION BAR 07716-0020500 or equivalent commercially available in U.S.A.
- (2) LOCK NUT WRENCH, 30 x 32 mm 07716-0020400 or equivalent commercially available in U.S.A.

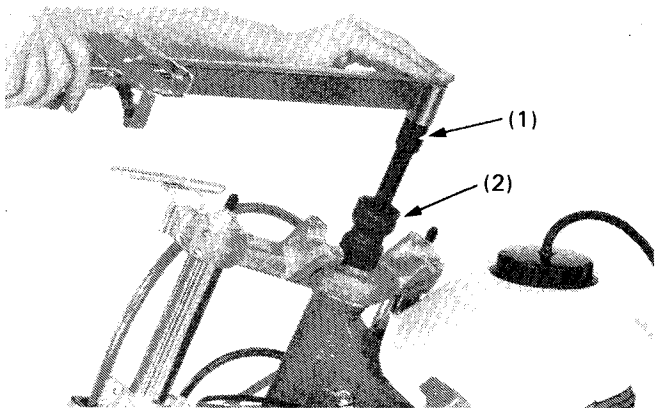

Install the front forks (page 11-20).

Install the following parts:

- cable guide
- front fender
- front wheel (page 11-13)
- handlebar (page 11-3)
- headlight case.

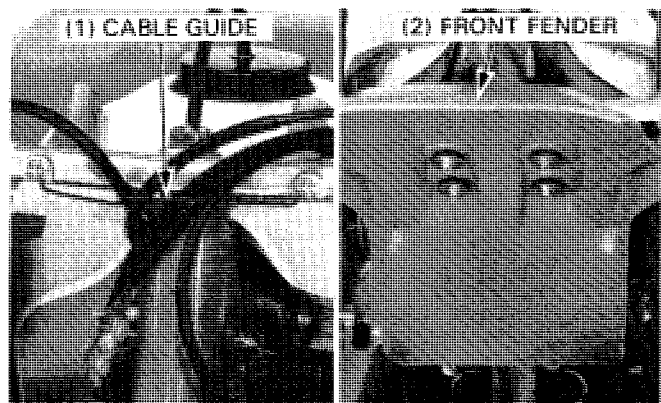

MEMO

REAR WHEELS

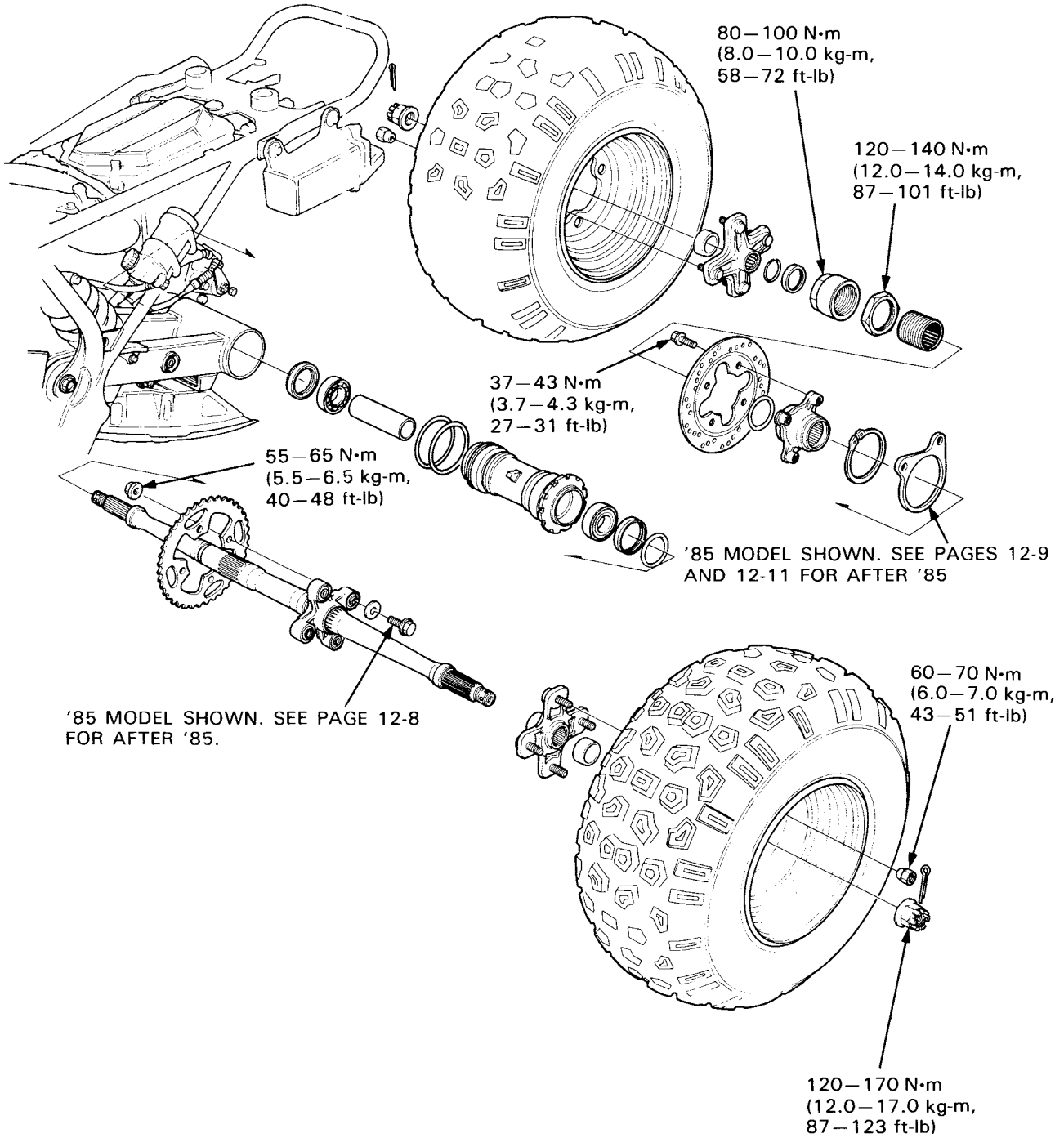

12. REAR WHEELS

SERVICE INFORMATION	12-1	REAR AXLE	12-3
TROUBLESHOOTING	12-2	REAR WHEEL BEARINGS	12-9
REAR WHEEL	12-3		

SERVICE INFORMATION

GENERAL

- This section covers maintenance of the rear wheel and drive mechanism.
- A jack or block is required to support the ATC.
- When using the lock nut wrench tool, use a deflecting beam type torque wrench 14–20 inches long. The lock nut wrench increases the torque wrench's leverage, so the wrench reading will be less than the torque actually applied. The torque scale reading is given with the actual torque specifications.
- For tire repair, see page 11-8.
- For tire removal, see page 11-10.

SPECIFICATIONS

ITEM		STANDARD	SERVICE LIMIT
Axle runout		—	3.0 mm (0.12 in)
Wheel rim runout	Radial	—	4.0 mm (0.16 in)
	Axial	—	4.0 mm (0.16 in)

TORQUE VALUES

Wheel nut	60–70 N·m (6.0–7.0 kg-m, 43–51 ft-lb)
Brake disc bolts	37–43 N·m (3.7–4.3 kg-m, 27–31 ft-lb)
Axle outer lock nut	80–100 N·m (8.0–10.0 kg-m, 58–72 ft-lb) Left-hand threads
Axle inner lock nut	120–140 N·m (12.0–14.0 kg-m, 87–101 ft-lb) Left-hand threads
Brake caliper bracket bolts	20–30 N·m (2.0–3.0 kg-m, 15–22 ft-lb)
Driven sprocket bolts	55–65 N·m (5.5–6.5 kg-m, 40–48 ft-lb)
Axle nuts	120–170 N·m (12.0–17.0 kg-m, 87–123 ft-lb)
Bearing holder socket bolts	13–18 N·m (1.3–1.8 kg-m, 9–13 ft-lb)

TOOLS

Special

Lock nut wrench, 56 mm	07916–HA20000 or 07916–HA2010A (U.S.A. only)
Lock nut wrench, 45 mm	07916–1870101 or equivalent commercially available in U.S.A.

Common

Driver	07749–0010000
Attachment, 62 x 68 mm	07746–0010500
Pilot, 40 mm	07746–0040900

TROUBLESHOOTING

Wheel wobble or vibration in vehicle

- Bent rim.
- Loose wheel bearings.
- Faulty axle bearing holder.
- Faulty tire.
- Loose axle.
- Worn or damaged swing arm pivot bearings.

REAR WHEEL

REMOVAL

Raise the rear wheels off the ground by placing a jack or block under the engine.

Remove the rear wheel nuts and the wheels.

DISASSEMBLY

For tire disassembly, assembly and repair, refer to Pages 11-8 to 11-13.

INSTALLATION

Install both rear wheels with the tire valve facing out. Tighten the wheel nuts.

TORQUE: 60–70 N·m (6.0–7.0 kg·m, 43–51 ft·lb)

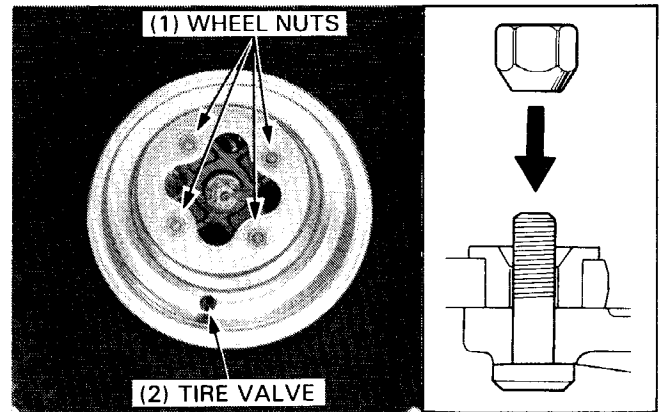

REAR AXLE

REMOVAL

Remove the rear wheels.

Remove the cotter pins, axle nuts, collars and wheel hubs from the axle.

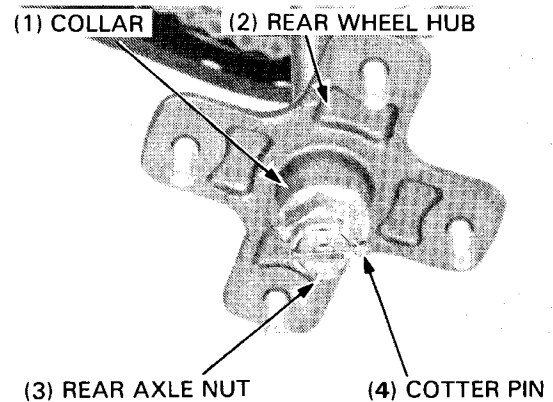

Loosen the drive chain adjuster (page 3-9)

Remove the drive chain retaining clip, master link and drive chain.

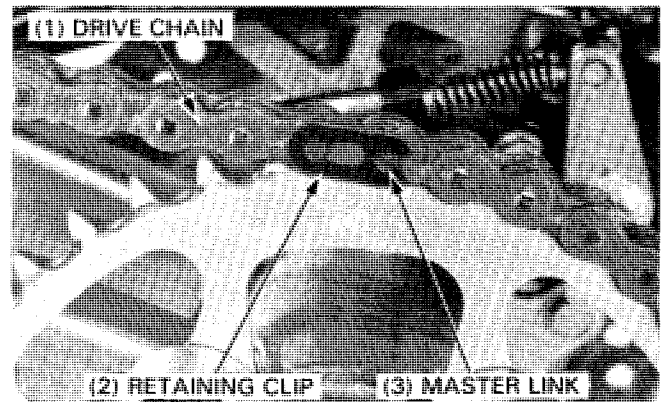

Move the ends of the axle back and forth, and up and down to check the wheel bearing play. If the play is excessive, replace the wheel bearings (page 12-9).

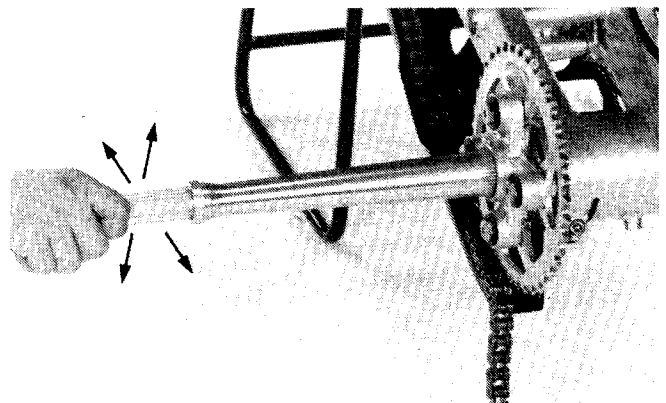

REAR WHEELS

Remove the sprocket nuts, bolts and sprocket from the sprocket hub.

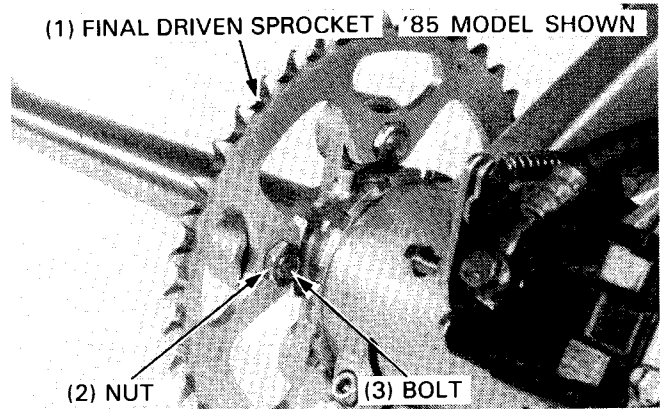

Remove the caliper bracket mounting bolts and raise the caliper off the brake disc.

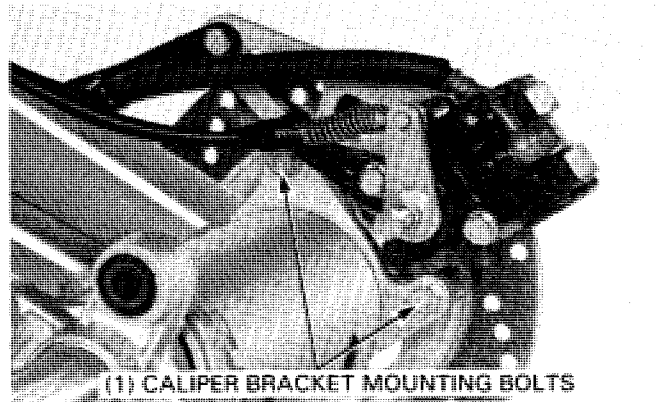

Loosen the axle inner lock nut while holding the outer lock nut.

NOTE

- The lock nuts have left-hand threads.

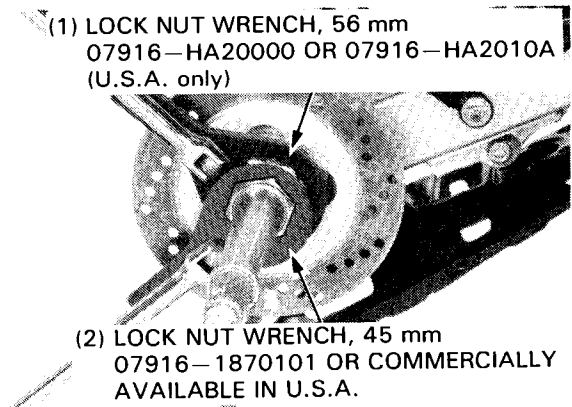

Temporarily install the left wheel hub and wheel.

Loosen the outer lock nut until the snap ring can be removed.

NOTE

- The lock nuts have left-hand threads.

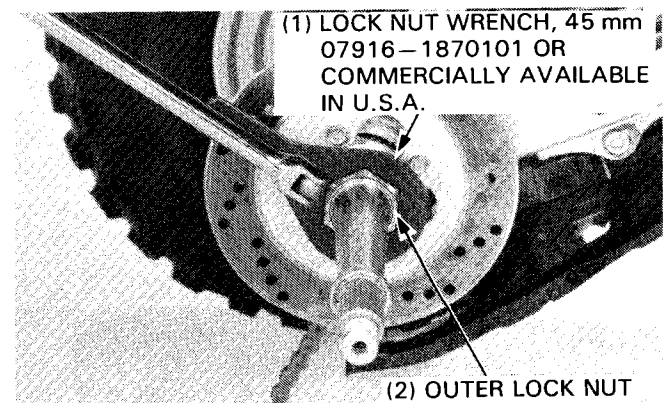

Remove the snap ring, snap ring collar, outer lock nut, lock nut thread and inner lock nut from the axle.

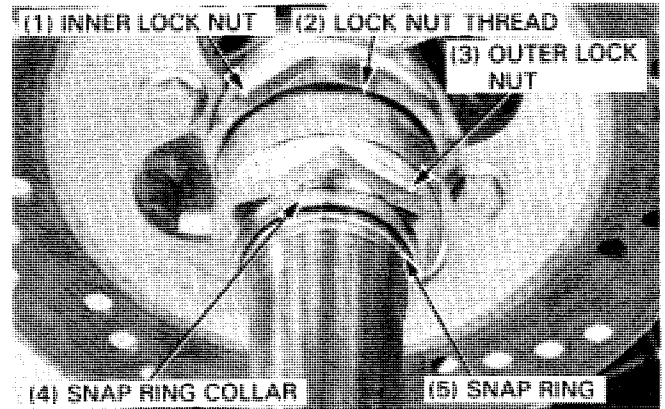

Remove the left wheel and hub.
Remove the brake disc with the hub from the axle.

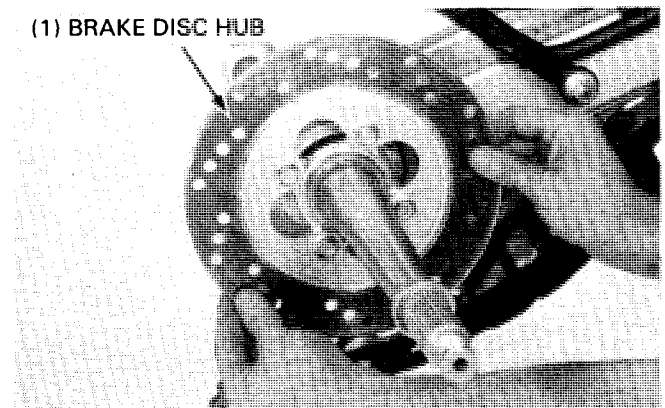

Remove the O-ring from the groove in the disc hub.

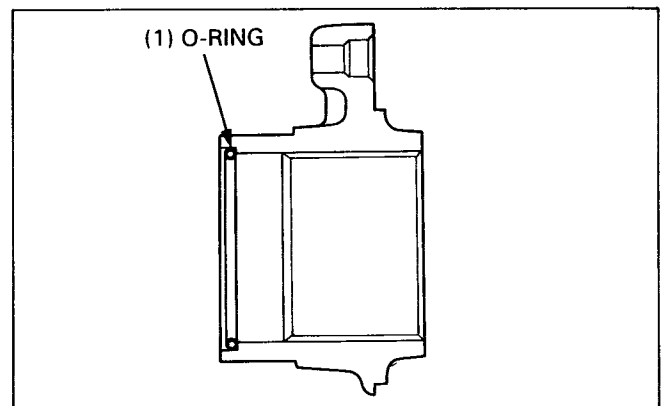

Install the axle nut onto the right axle end.
Drive the axle out of the wheel bearings from the right side with a plastic hammer.

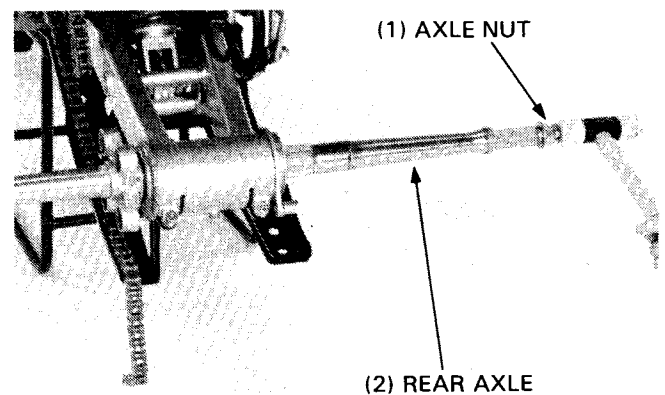

REAR WHEELS

Remove the O-ring from the axle.

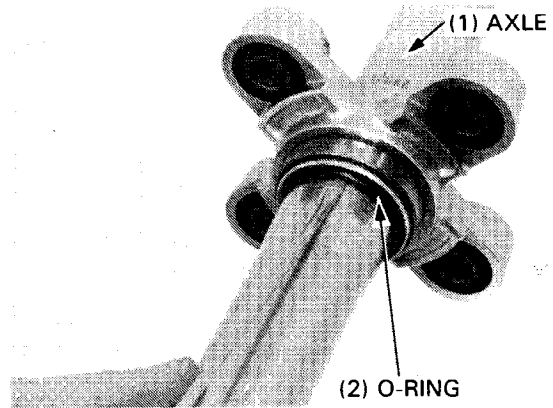

INSPECTION

Place the axle in V-blocks and measure the runout.

SERVICE LIMIT: 3.0 mm (0.12 in)

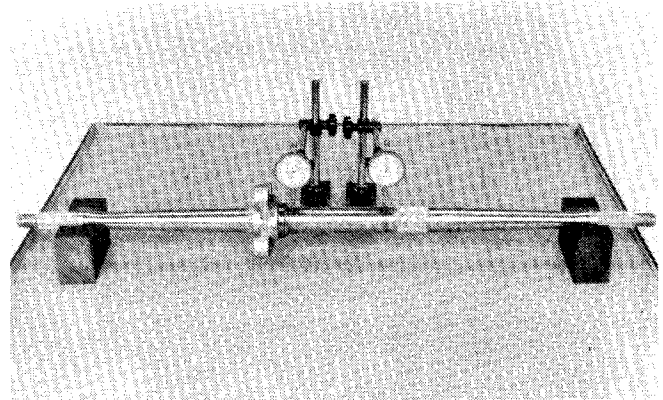

INSTALLATION

Place a new O-ring on the axle and install the axle from the left side.

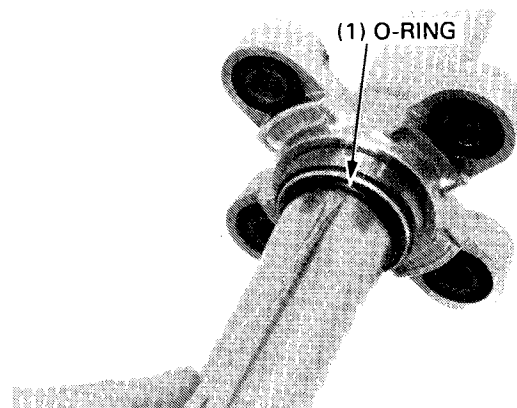

Install a new O-ring in the groove in the brake disc hub.
Install the brake disc hub.

WARNING

- *Grease or oil on the disc will reduce stopping power. Clean the disc with a high quality brake degreaser if oil or grease gets on the disc.*

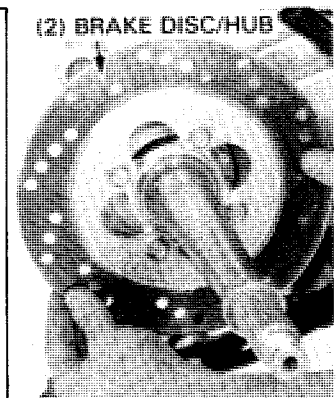
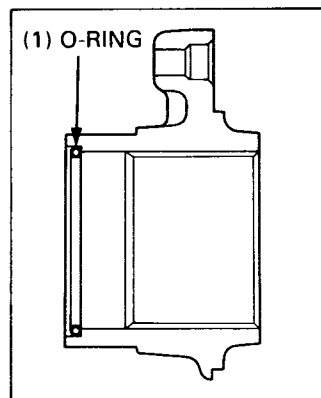

Apply a thread locking agent to the inner lock nut threads.

Thread the inner and outer lock nuts over the lock nut thread and install them onto the axle.

Install the snap ring collar and snap ring.

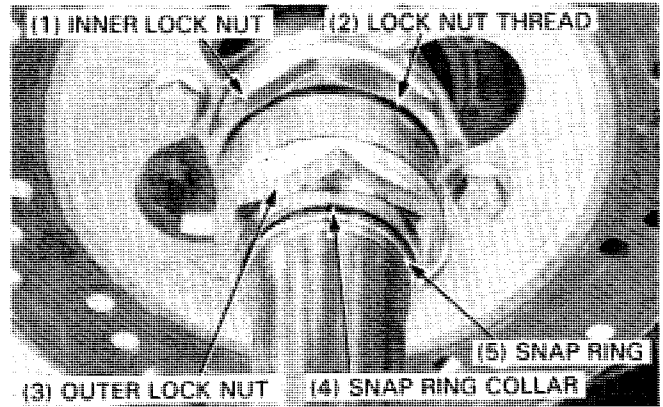

Temporarily install the left rear wheel hub and wheel.

Tighten the outer lock nut to the specified torque against the snap ring collar while holding the left rear wheel.

TORQUE: 80–100 N·m (8.0–10.0 kg-m, 58–72 ft-lb)

NOTE

- The inner and outer lock nuts have left-hand threads.

Remove the left rear wheel and wheel hub.

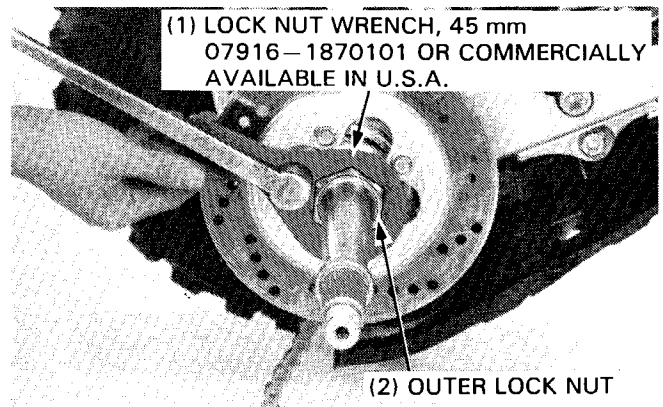

Tighten the inner lock nut against the outer lock nut.

TORQUE: 120–140 N·m (12.0–14.0 kg-m, 87–101 ft-lb)

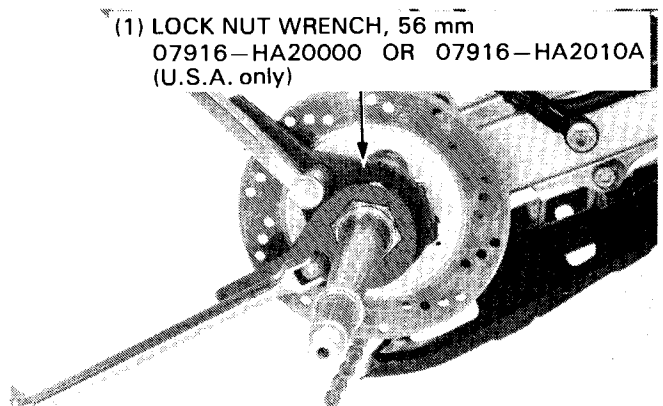

Lower the brake caliper over the disc and tighten the caliper bracket bolts.

TORQUE: 20–30 N·m (2.0–3.0 kg-m, 15–22 ft-lb)

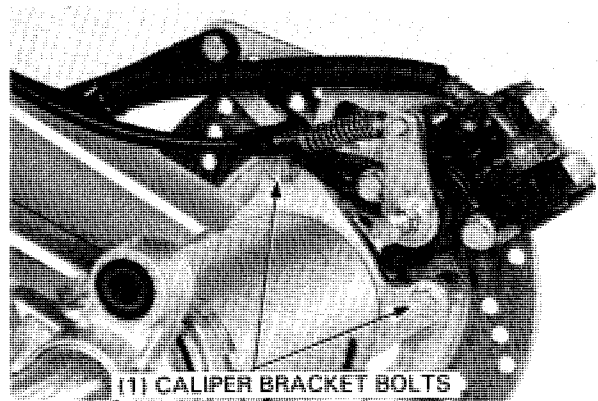

REAR WHEELS

Install the driven sprocket onto the hub with its stamped number of teeth mark facing out. Tighten the sprocket bolts.

TORQUE: 55–65 N·m (5.5–6.5 kg-m, 40–48 ft-lb)

After '85:

Apply grease to the step of the hub. Install the guide plate and driven sprocket onto the hub with the stamped teeth number facing out. Tighten the sprocket nuts.

TORQUE: 55–65 N·m (5.5–6.5 kg-m, 40–48 ft-lb)

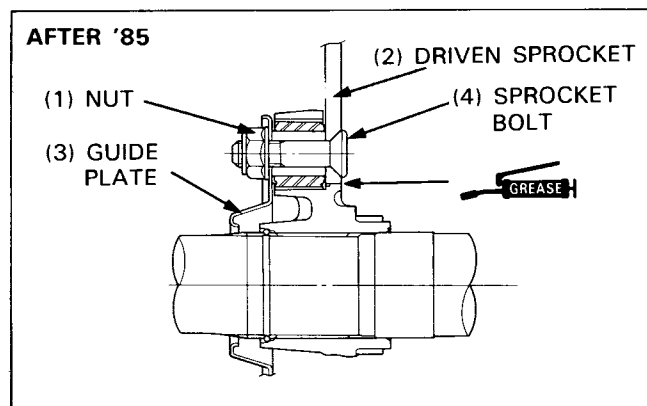
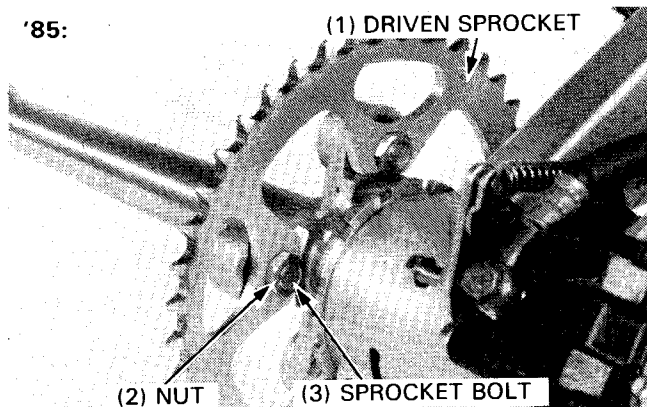

Install the drive chain with the master link and retaining clip. Face the closed end of the retaining clip in the rotating direction of the chain.

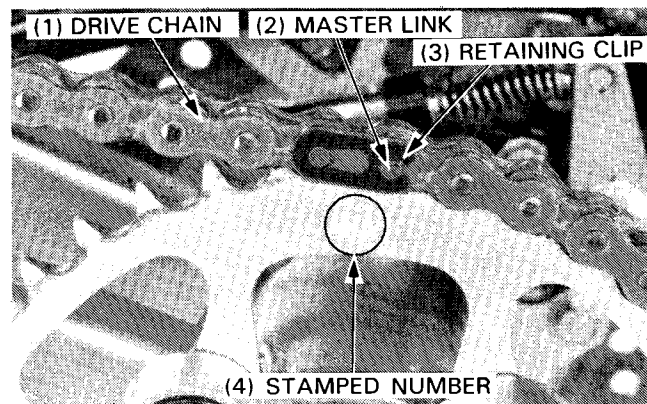

Apply grease to the splines on both ends of the axle.

Install the wheel hubs, wheel hub collars, and axle nuts. Tighten the axle nuts.

TORQUE: 120–170 N·m (12.0–17.0 kg-m, 87–123 ft-lb)

Install new cotter pins and spread the ends as shown.

Install the rear wheels (page 12-3).

Adjust drive chain slack (page 3-9).

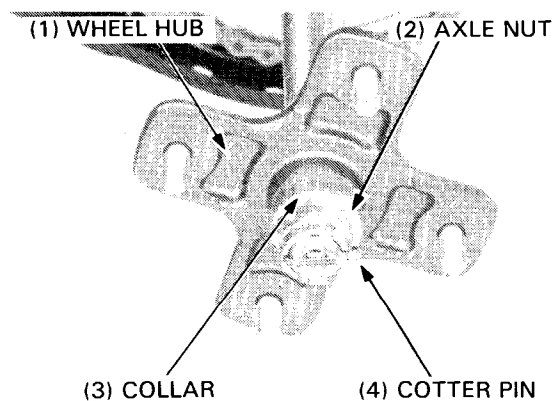

REAR WHEEL BEARINGS

BEARING HOLDER REMOVAL

Remove the rear wheels and axle (page 12-3).

Remove the snap ring and the brake caliper mounting plate.

(1) BRAKE CALIPER FLATE

(2) SNAP RING

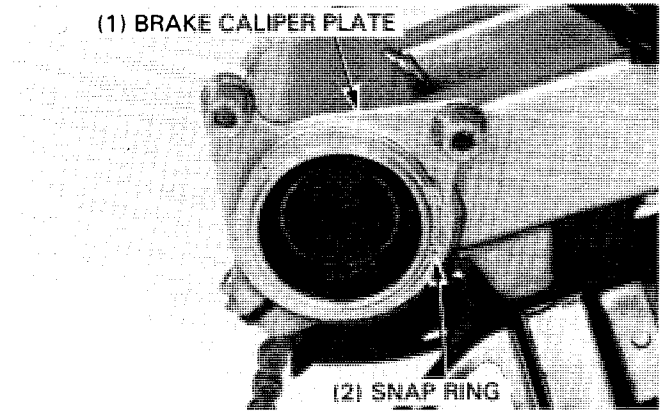

After '85:

Remove the snap ring and brake caliper mounting plate. If necessary, remove the snap ring and collar from the stud on the swing-arm.

(1) SNAP RING

(2) CALIPER MOUNTING PLATE

(3) SNAP RING AND COLLAR

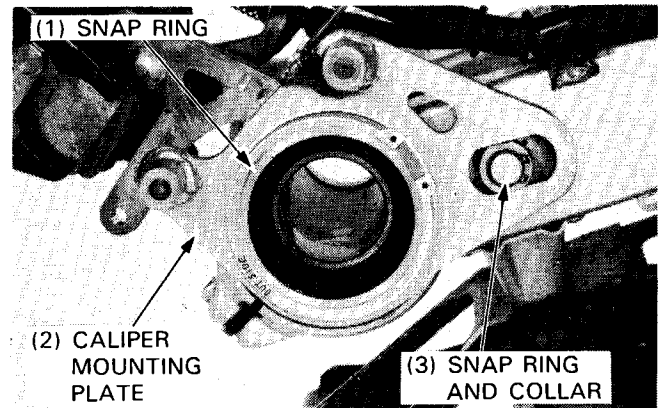

Remove the two socket bolts and rubber seals from the swing arm.

Remove the stopper bolt.

(1) SOCKET BOLTS

(2) RUBBER SEAL

(3) STOPPER BOLT

(2) RUBBER SEAL

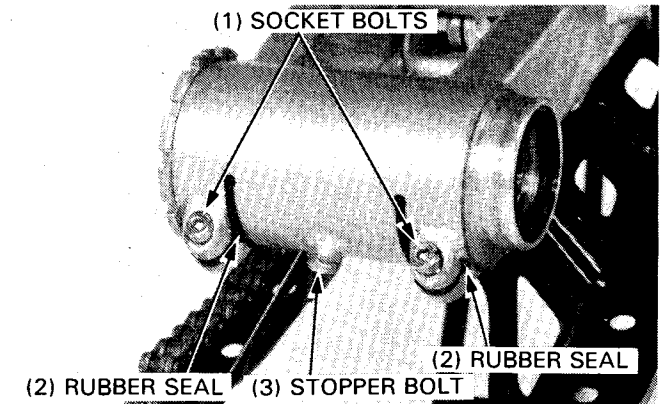

Remove the bearing holder from the swing arm. Remove the O-rings from the bearing holder.

(1) O-RINGS

(2) BEARING HOLDER

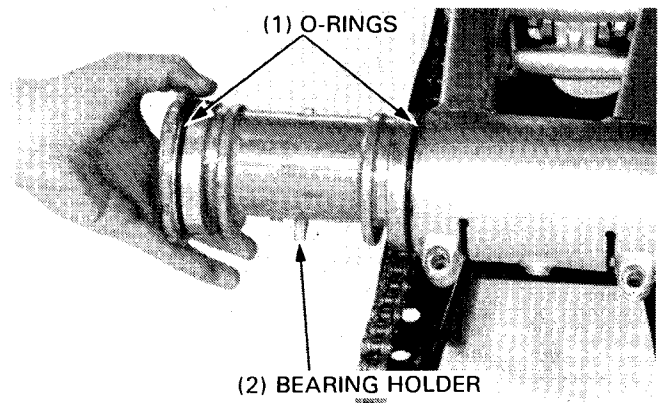

REAR WHEELS

BEARING REPLACEMENT

Remove the dust seals, bearings and center spacer from the bearing holder.

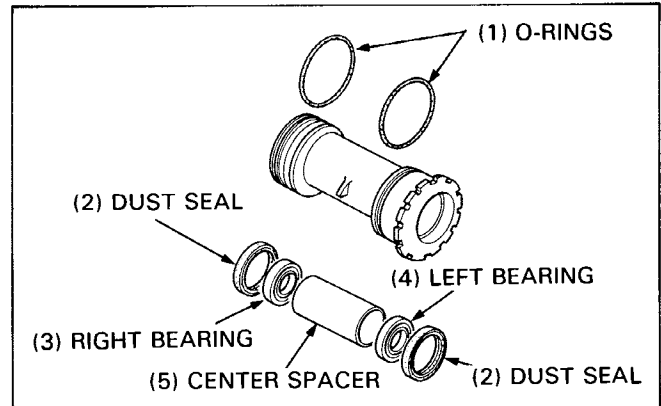

Drive a new right bearing into the bearing holder with the special tools.

Install the center spacer.

Drive a new left bearing into place with the same tools.

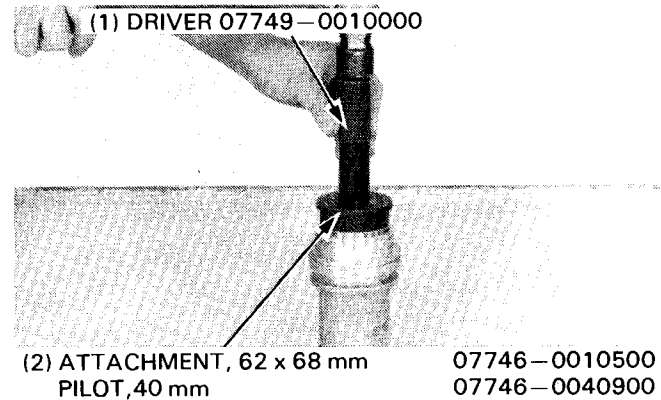

Apply grease to the lip of new dust seals and drive the dust seals into the bearing holder until their out side surfaces are flush with the end surfaces of the holder.

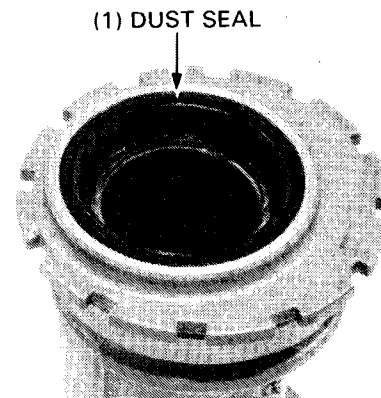

BEARING HOLDER INSTALLATION

Install new O-rings in the grooves of the bearing holder.

Apply grease to the outside surfaces of the bearing holder and install it in the swing arm.

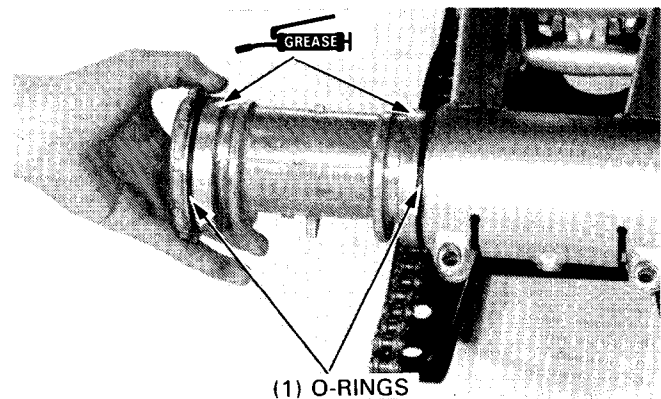

Install the rubber seals and stopper bolt.
Apply grease to the caliper mount plate installation surface of the bearing holder.

Temporarily install the socket bolt.

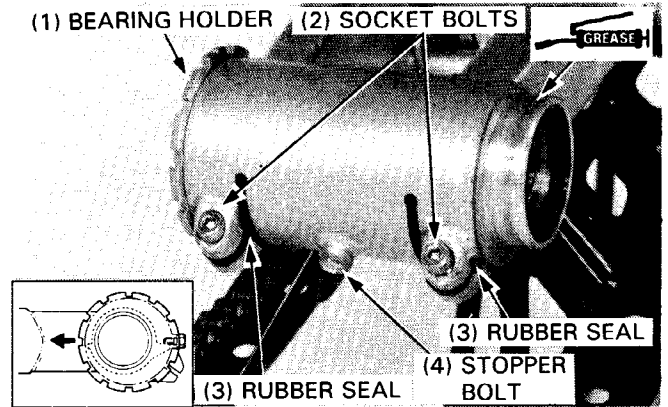

'85:

Install the caliper mount plate.

Install the snap ring with its "OUT SIDE" mark facing out and with its ends positioned as shown.

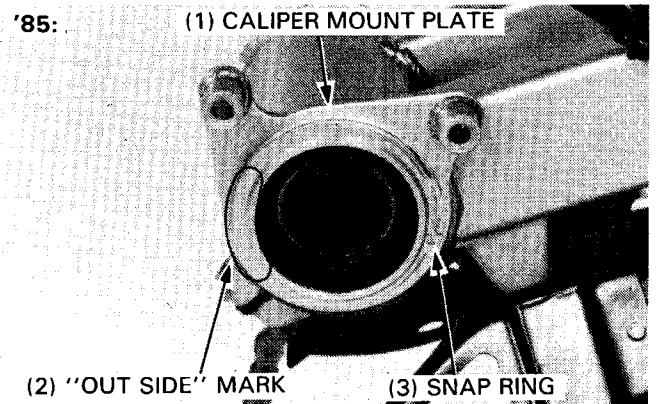

After '85:

Install the collar onto the stud on the swing arm.
Install the caliper mount plate onto the swing arm.
Install the large snap ring with "OUT SIDE" mark facing out and with its ends positioned as shown.

Install the snap ring onto the stud with its radiused edge facing out.

Install the rear axle (page 12-6).
Install the rear wheels (page 12-3).
Adjust the drive chain (page 3-8).

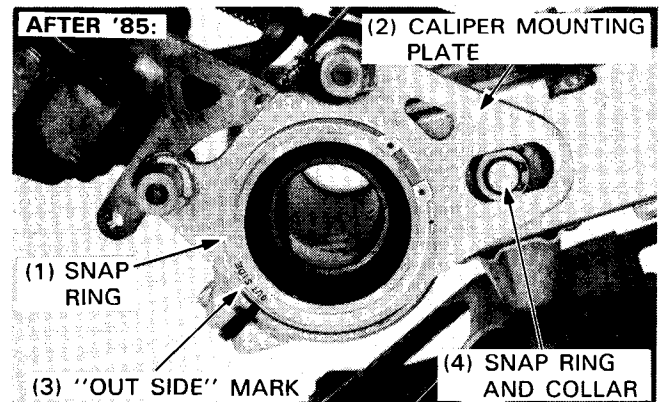

REAR SUSPENSION

70–110 N·m
(7.0–11.0 kg·m,
51–80 ft·lb)

40–50 N·m
(4.0–5.0 kg·m,
29–36 ft·lb)

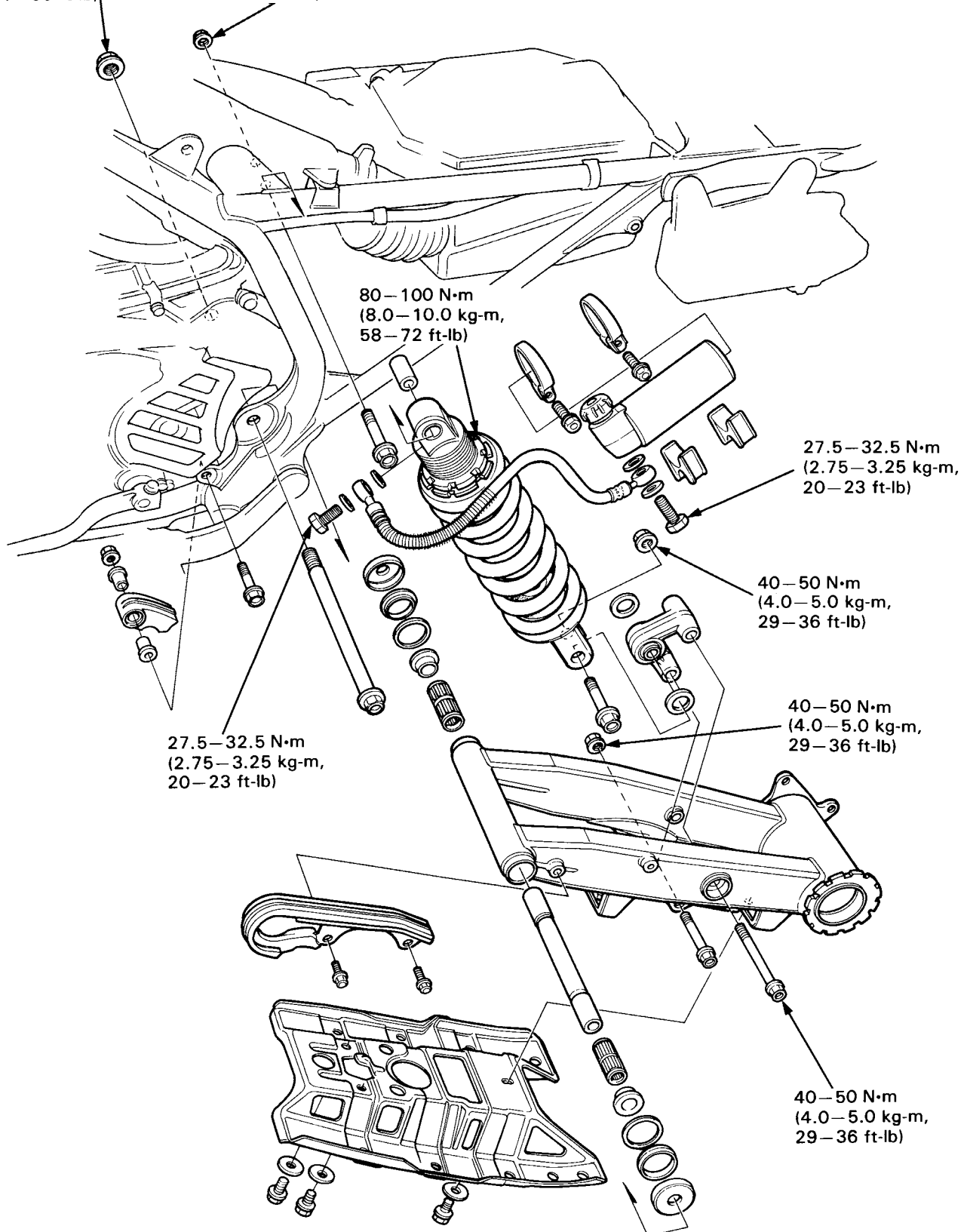

13. REAR SUSPENSION

SERVICE INFORMATION	13-1	SHOCK ABSORBER	13-3
TROUBLESHOOTING	13-2	SWING ARM	13-10

SERVICE INFORMATION

GENERAL

- This section deals with rear shock absorber and swing arm repairs.
- A jack or block is required to support the ATC.
- Use only genuine Honda bolts for the shock absorber pivot and mounting; ordinary bolts lack adequate strength for these applications. Also take note of the installation direction of these bolts since they must be installed correctly.

WARNING

- *The shock absorber is fitted with a gas-filled reservoir. Do not fill the reservoir with air; use only nitrogen and have the shock pressure checked and/or charged by an authorized Honda dealer equipped with a proper nitrogen charging system.*
- *The shock absorber contains nitrogen under high pressure. Do not allow fire or heat near the shock and be sure to release the nitrogen gas pressure before discarding the shock.*

SPECIFICATIONS

ITEM	STANDARD	SERVICE LIMIT
Rear shock absorber spring free length	230 mm (9.06 in)	224.7 mm (8.85 in)
Nitrogen pressure	2,000–2,300 kPa (20–23 kg/cm ² , 284–327 psi)	—

TORQUE VALUES

Shock absorber oil hose bolt	27.5–32.5 N·m (2.75–3.25 kg-m, 20–23 ft-lb)
Shock absorber spring lock nut	80–100 N·m (8.0–10.0 kg-m, 58–72 ft-lb)
Shock absorber upper mount bolt	40–50 N·m (4.0–5.0 kg-m, 29–36 ft-lb)
Shock absorber lower mount bolt	40–50 N·m (4.0–5.0 kg-m, 29–36 ft-lb)
Shock absorber bracket bolts	40–50 N·m (4.0–5.0 kg-m, 29–36 ft-lb)
Swing arm pivot bolt	70–110 N·m (7.0–11.0 kg-m, 51–80 ft-lb)
Rear brake torque link-to-swing arm nut ('85)	8–11 N·m (0.8–1.1 kg-m, 6–8 ft-lb)

TOOLS

Special

Needle bearing remover	07946–KA50000 or driver 07749–0010000, attachment, 32 x 35mm 07746–0010100 and pilot, 20 mm 07746–0040500 (U.S.A. only)
Needle bearing remover	07931–MA70000 or bushing remover M967X–038–XXXXX and common drift (U.S.A. only)

Optional

Pin spanner	89201–KA4–820
Pin spanner	89202–KA4–820

TROUBLESHOOTING

Wobble or vibration in motorcycle

- Bent rim.
- Loose wheel bearing(s).
- Damaged tire.
- Axle not tightened properly.
- Swing arm pivot bearing worn.
- Bent frame or swing arm.

Soft suspension

- Spring preload adjustment is improper for rider's weight—See Owner's Manual.
- Compression damping adjustment improper—See Owner's Manual.
- Weak shock spring.

Hard suspension

- Spring preload is improper for rider's weight—See the Owner's Manual.
- Compression or rebound damping is misadjusted—See Owner's Manual.
- Bent shock damper rod.
- Swing arm pivot bearings damaged.
- Frame or swing arm bent.

Suspension noise

- Faulty rear damper.
- Loose fasteners.

SHOCK ABSORBER

REMOVAL

Raise the rear wheels off the ground by placing a jack or block under the engine.

Remove the seat/rear fender.

Remove the reservoir from the frame by removing the two mount bolts.

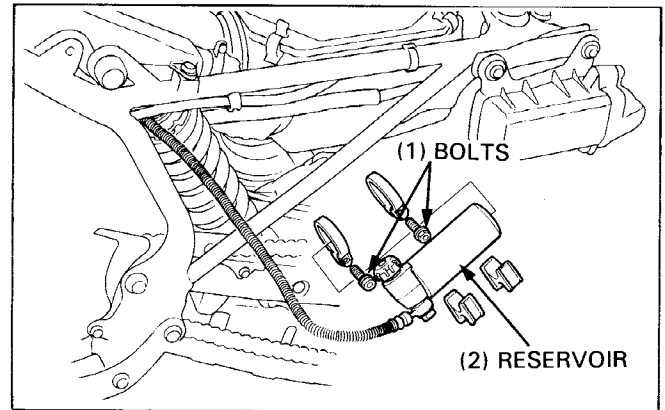

Remove the two shock absorber bracket bolts.

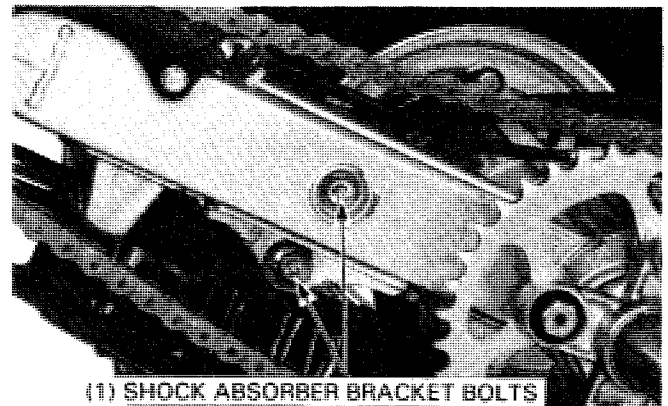

Remove the shock upper mount bolt and the shock.

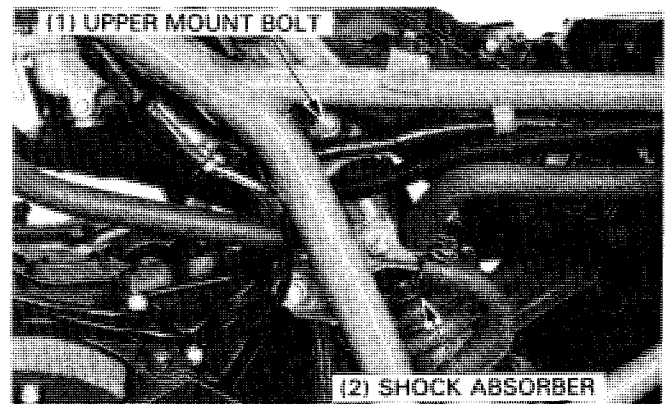

Remove the lower mount bolt and bracket.

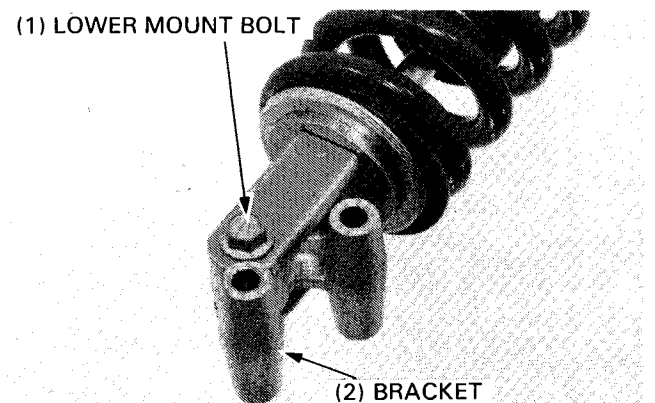

REAR SUSPENSION

SPRING REMOVAL

Hold the lower shock mount in a vise with soft jaws or a shop towel and loosen the lock and adjusting nuts.

CAUTION

- *Be careful not to damage the hose connection with the vise.*

NOTE

- The pin spanners are optional tools.

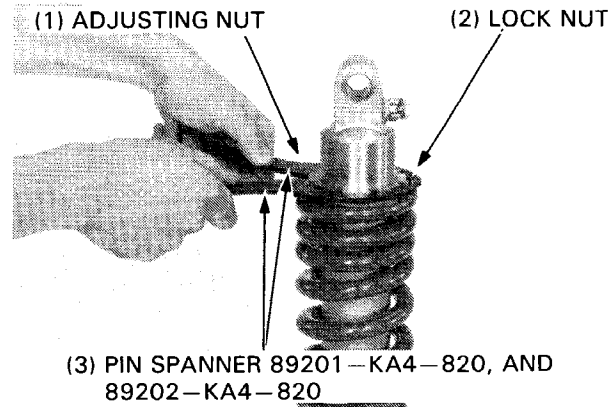

Remove the spring seat stopper, spring seat and spring.

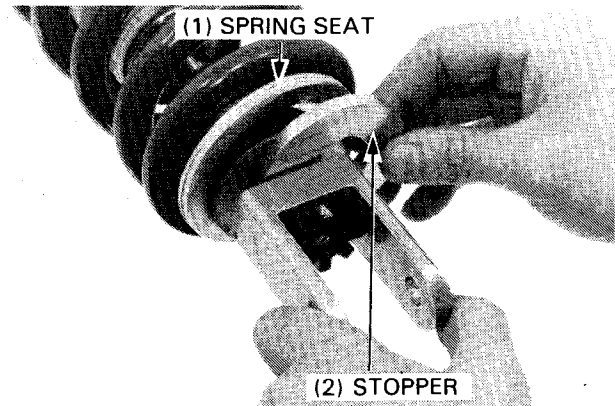

SPRING INSPECTION

Measure the spring free length.

SERVICE LIMIT: 224.7 mm (8.85 in)

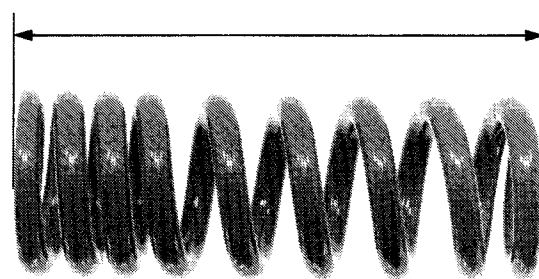

DISASSEMBLY

Remove the reservoir valve cap.

Depress the Schrader valve to release the nitrogen from the reservoir.

CAUTION

- *Point the reservoir charging valve away from you when discharging the nitrogen pressure.*
- *Do not remove the valve core before discharging the nitrogen pressure.*

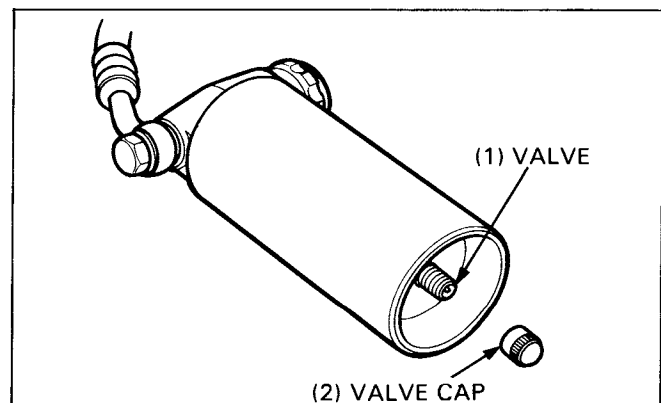

Remove the oil bolts and sealing washers, and disconnect the oil hose from the damper and the reservoir.

Drain the oil from the reservoir, hose and damper.

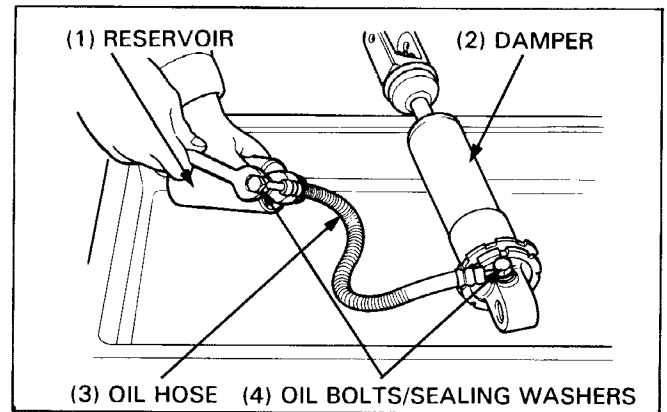

ASSEMBLY

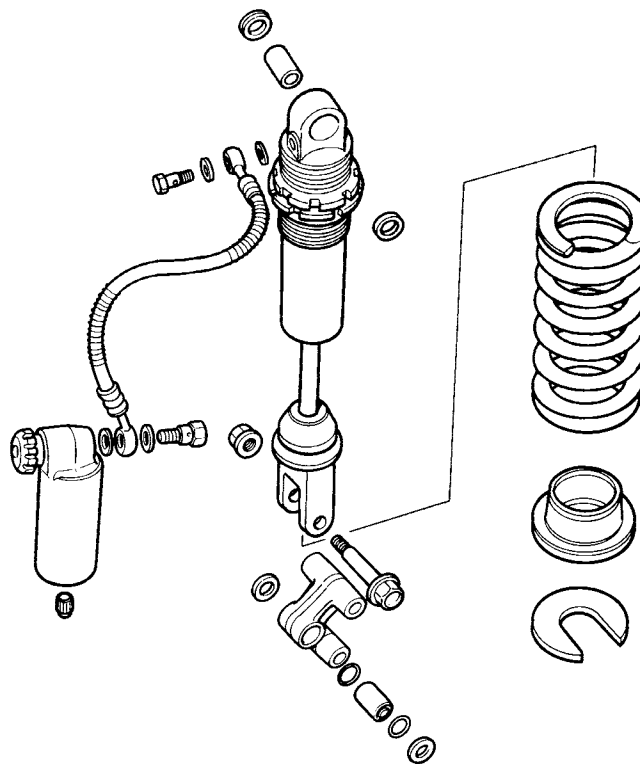

Hold the upper shock mount in a vise with soft jaws or a shop towel. Point the hole straight up.

Pull out the damper rod all the way and fill the damper with ATF.

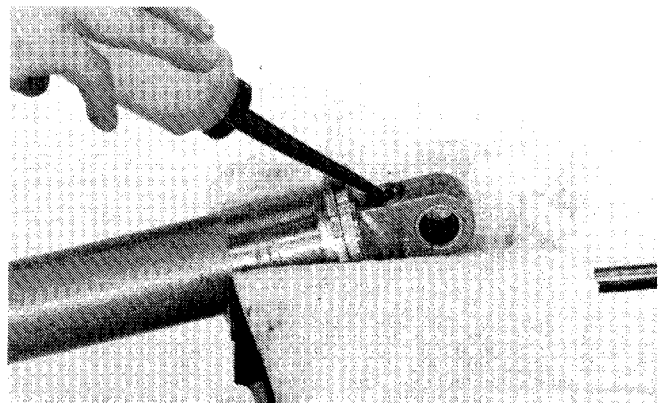

REAR SUSPENSION

Bleed air from the damper by moving the damper rod with short strokes, in and out several times slowly.

Fill the damper with ATF as required.

NOTE

- The damper should be as free of air as possible.

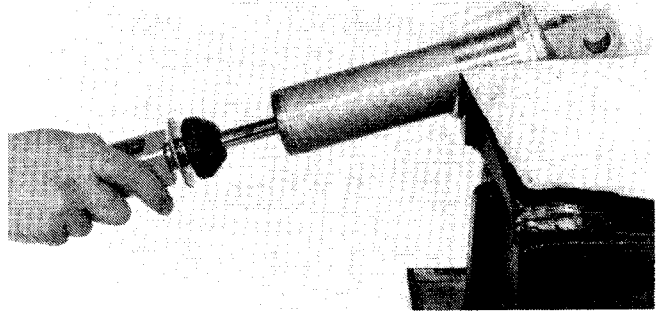

Fill the reservoir with ATF.

NOTE

- Make sure that there is no gas pressure in the reservoir.

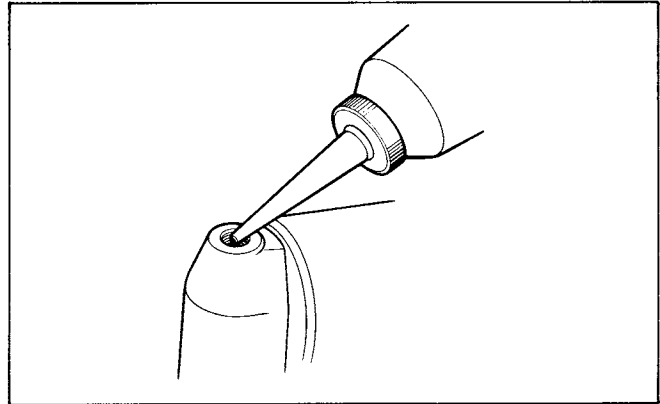

Fill the hose with ATF.

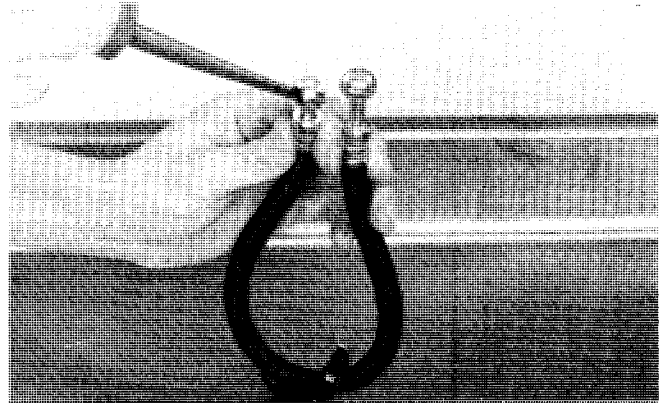

Make sure that the sealing washer is in good condition.

Connect the oil hose to the damper using the two sealing washers and oil bolt and align the marks on the hose banjo and damper.

Tighten the oil bolt.

TORQUE: 27.5–32.5 N·m (2.75–3.25 kg-m, 20–23 ft-lb)

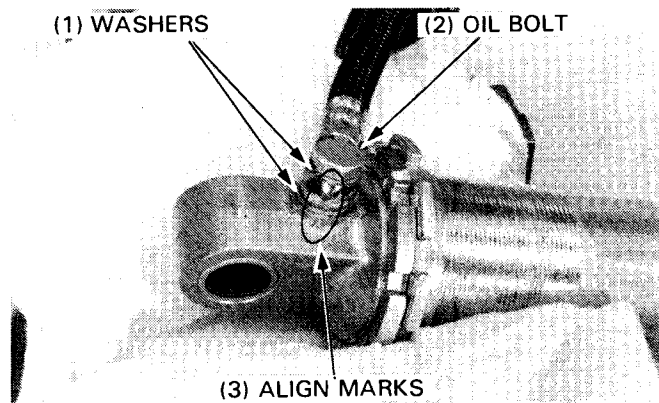

Very slowly push the damper rod in until ATF begins to overflow from the hose.

Pull the damper rod out all the way and fill the hose with ATF.

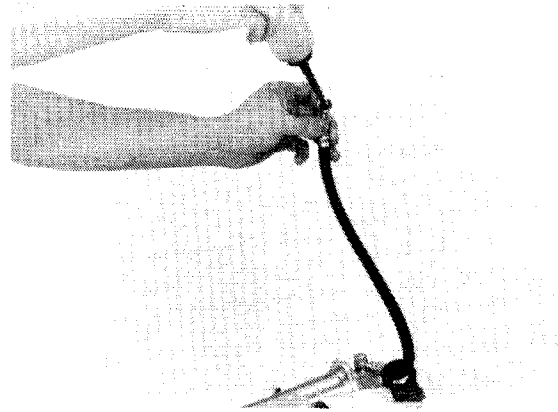

Very carefully connect the oil hose to the reservoir using the two sealing washers and oil bolt and align the punch marks on the oil hose and reservoir as shown.

Tighten the oil bolt.

TORQUE: 27.5–32.5 N·m (2.75–3.25 kg·m, 20–23 ft·lb)

Make sure that there is no air in the damper by operating the damper before charging the reservoir with gas.

If damper force is uneven, bleed air from the damper.

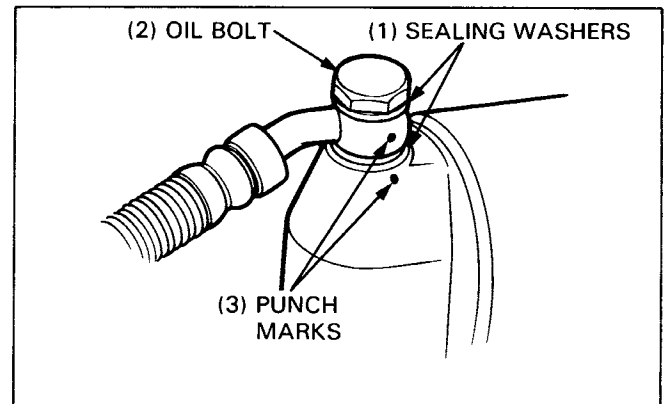

Fill the reservoir with nitrogen gas.

SPECIFIED GAS PRESSURE: 2,000–2,300 kPa (20–23 kg/cm², 284–327 psi)

WARNING

- *Use only nitrogen to pressurize the shock absorber. The use of an unstable gas can cause a fire or explosion.*

Install the valve cap.

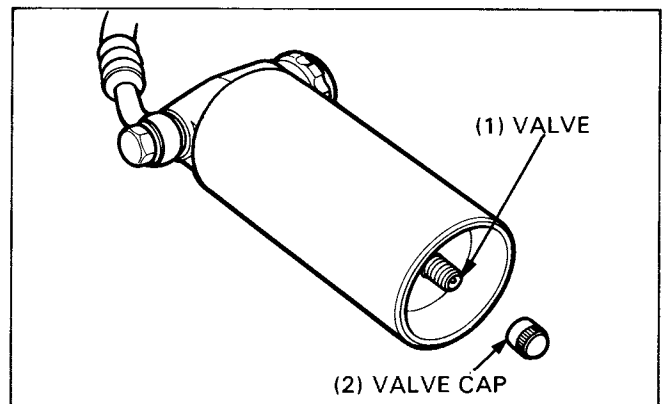

SPRING INSTALLATION

Install the spring, spring seat and spring seat stopper.

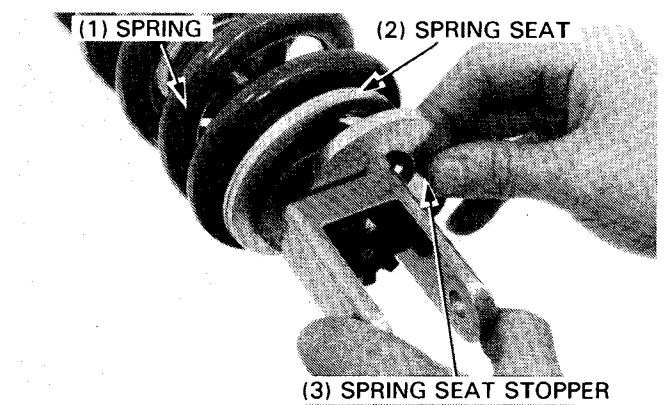

REAR SUSPENSION

Align the shock mounts so that the oil bolt and damping adjuster index mark on the lower mount face the rear.

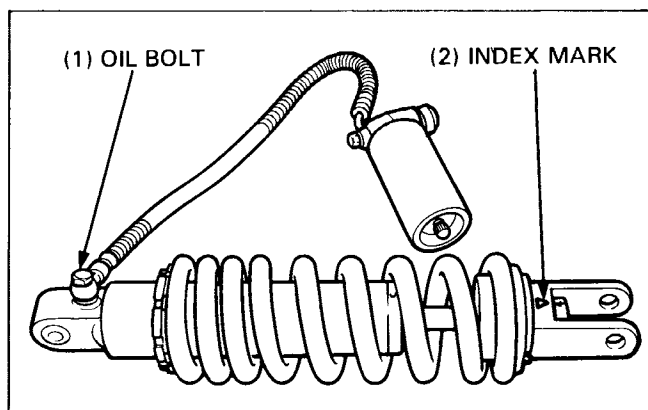

Turn the adjusting nut to obtain the correct spring length.

Measure the spring length.

STANDARD SPRING LENGTH: 225 mm (8.86 in)

MINIMUM SPRING LENGTH: 220 mm (8.66 in)

MAXIMUM SPRING LENGTH: 227 mm (8.94 in)

NOTE

- One turn of the adjusting nut changes the spring length by 1.5 mm (0.06 in).

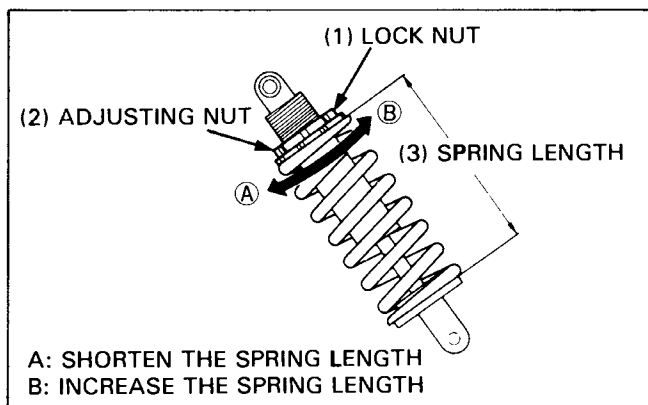

Use this standard spring preload length as a baseline. See the Owner's Manual for detailed instructions on adjusting preload for rider weight and setting damping for riding conditions and rider skill.

Tighten the lock nut while holding the adjusting nut.

TORQUE: 80–100 N·m (8.0–10.0 kg·m, 58–72 ft·lb)

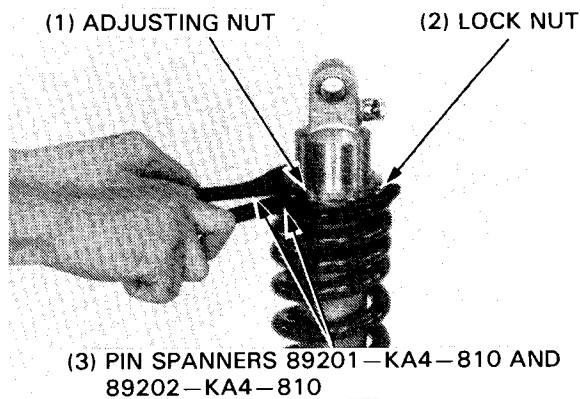

Apply grease to the shock bracket bushing. Install the shock bracket and two washers onto the shock with the bracket "UP" mark facing the rear and tighten the shock lower mount bolt and nut.

TORQUE: 40–50 N·m (4.0–5.0 kg·m, 29–36 ft·lb)

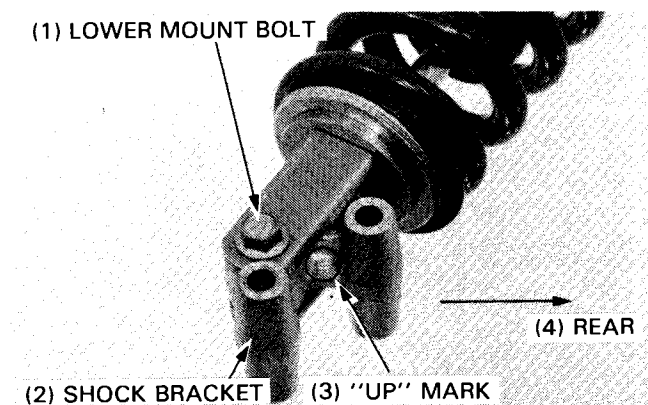

Apply a paste grease with 40% or more molybdenum disulfide to the upper mount collar and dust seals and install them into the upper mount.

NOTE

Some sources of MoS₂ paste grease with 40% or more molybdenum are:

- Molykote® G-n Paste manufactured by Dow Corning, U.S.A.
- Honda Moly 45 (U.S.A.)
- Locol Paste manufactured by Sumico Lubricant, Japan.
- Bel-Ray Moly-Lube MC-8, U.S.A.
- Sta Lube MP Grease #3141

Any other manufacturer's paste grease equivalent to the above may also be used.

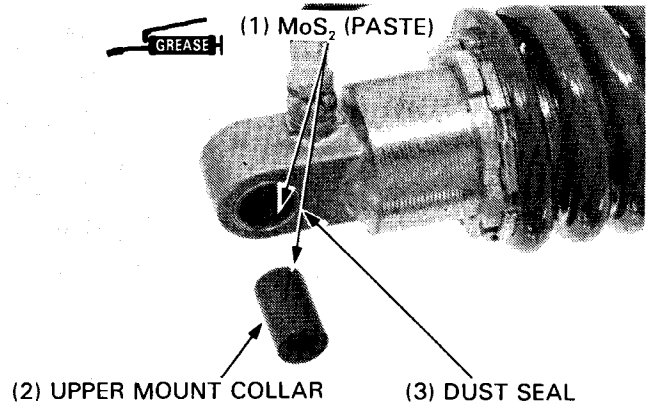

INSTALLATION

Connect the shock absorber upper mount to the frame and tighten the upper mount bolt.

TORQUE: 40–50 N·m (4.0–5.0 kg-m, 29–36 ft-lb)

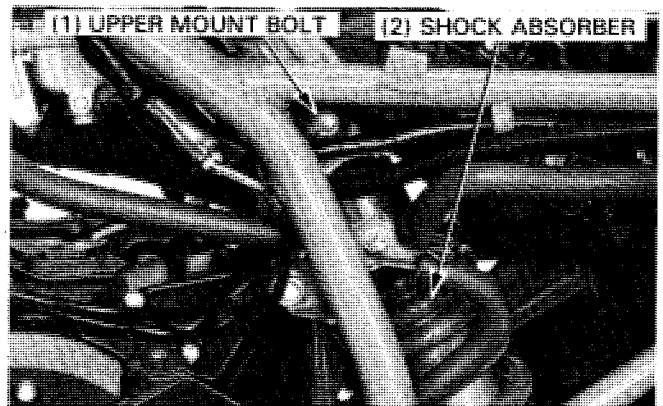

Connect the shock bracket to the swing arm and tighten the bracket bolts.

TORQUE: 40–50 N·m (4.0–5.0 kg-m, 29–36 ft-lb)

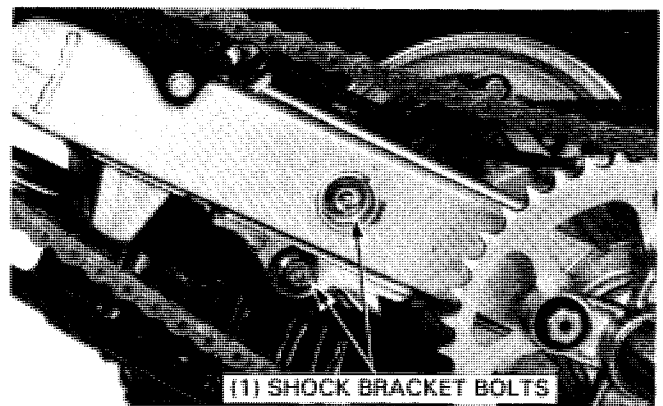

Install the reservoir to the frame using the band and two bolts.

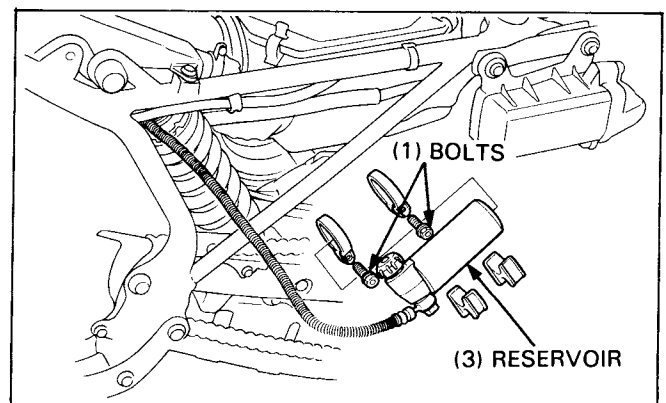

REAR SUSPENSION

SWING ARM

REMOVAL

Remove the following:

- rear wheels and axle (page 12-3)
- rear wheel bearing holder (page 12-9)
- shock bracket mount bolts.

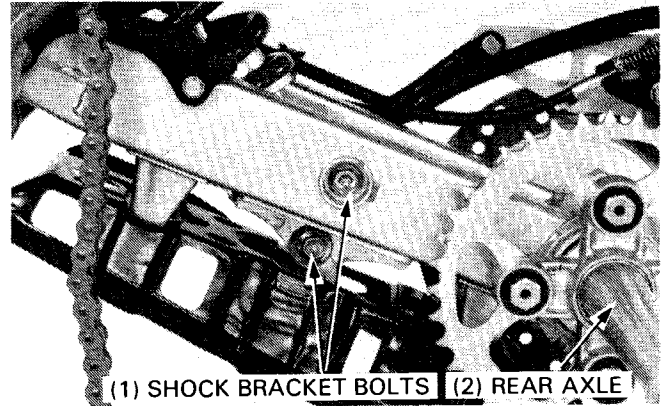

Remove the:

- brake torque link mount nut and lock washer ('85 only).
- brake hose and parking brake cable clamp bolt
- swing arm pivot nut, bolt and swing arm.

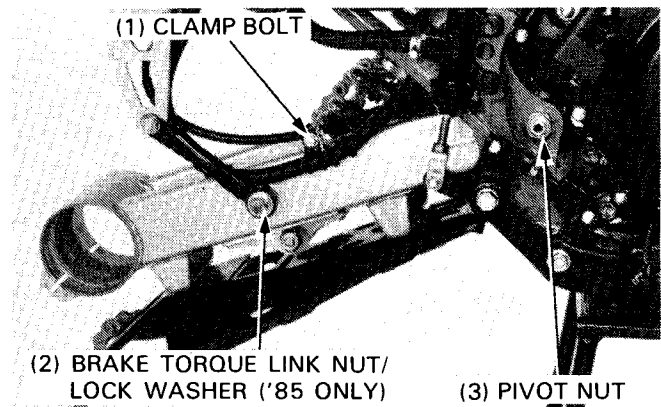

Remove the:

- swing arm lower guard bolts and guard
- chain slider bolts and slider
- dust seal caps, dust seals, washers and pivot collar.

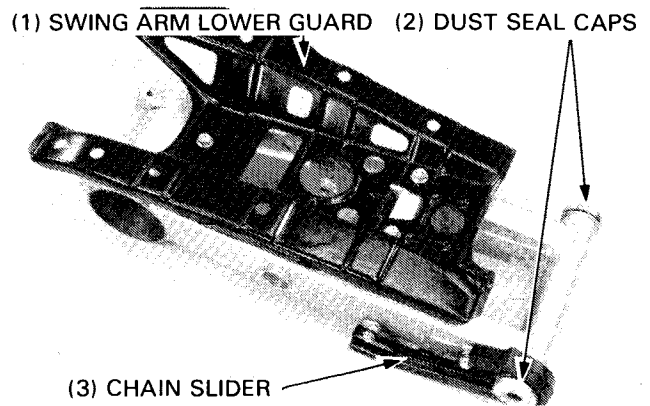

INSPECTION

Check the swing arm for damage and replace if necessary.

Check the swing arm pivot needle bearings, collars, and dust seals for wear or damage.

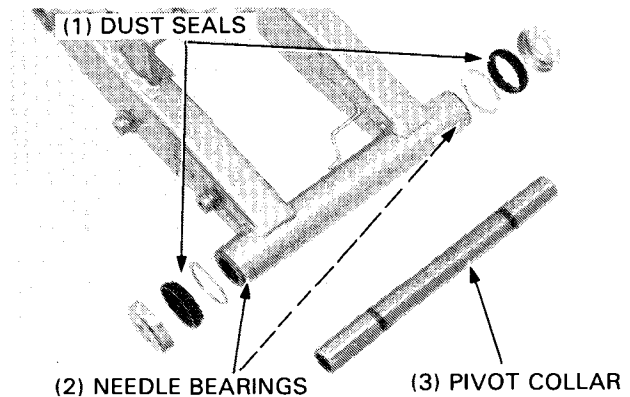

PIVOT BEARING REPLACEMENT

Remove the pivot side collars with a drift.

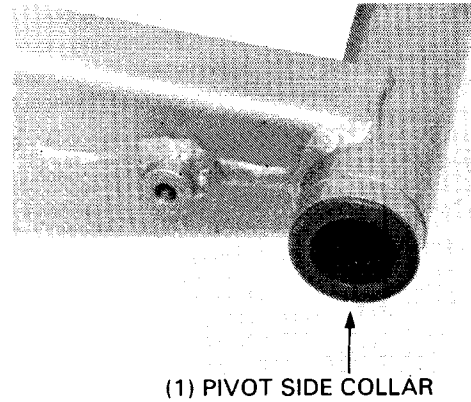

Remove the needle bearings using the special tool.

(1) NEEDLE BEARING REMOVER 07931—MA70000
OR BUSHING REMOVER M967X—038—XXXXX AND
COMMON DRIFT (U.S.A. only)

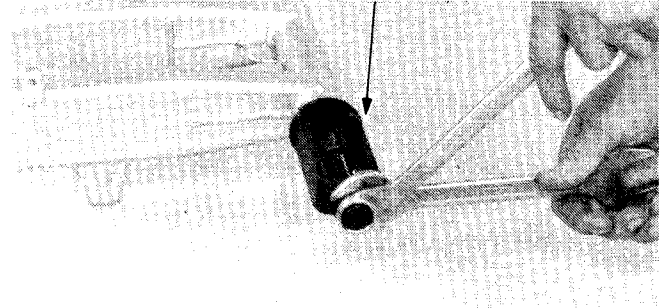

Press in new needle bearings until they are flush with the end surfaces of the pivot.

CAUTION

- *Install the needle bearings with their marked ends facing out.*

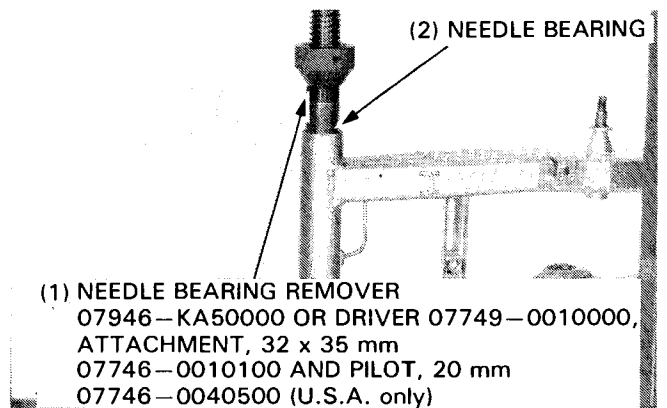

Place each pivot side collar on the needle bearing and press the side collars into the pivot.

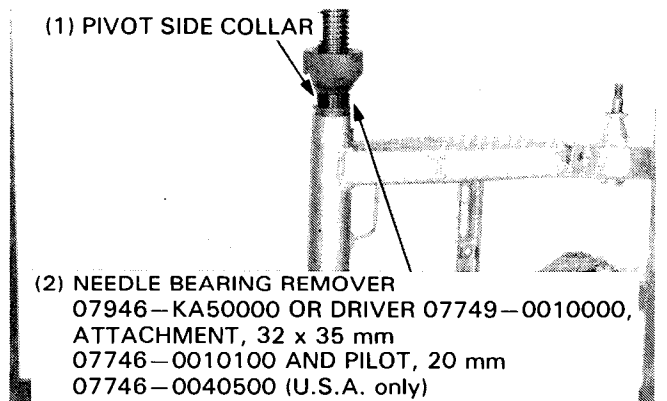

REAR SUSPENSION

INSTALLATION

Apply grease to the pivot collar and the lips of the dust seals.

Install the pivot collar, washers, dust seals and dust seal caps onto the swing arm pivot.

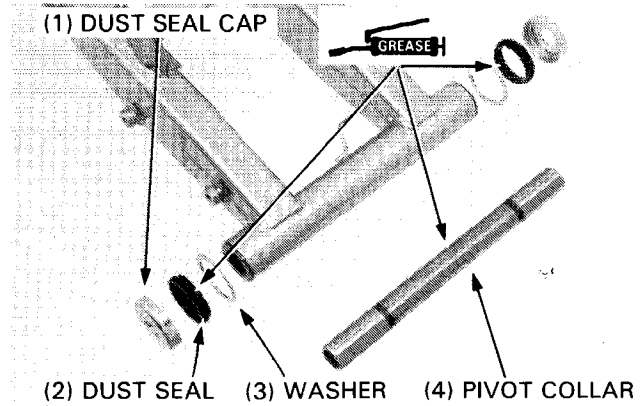

Install the chain slider onto the swing arm using the bolts.

Install the swing arm lower guard with the bolts.

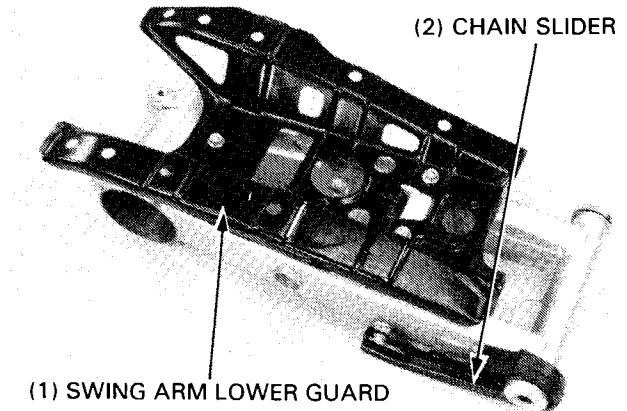

Place the swing arm into the frame and install the pivot bolt and nut. Tighten the pivot nut.

TORQUE: 70–110 N·m (7.0–11.0 kg-m, 51–80 ft-lb)

Install the brake hose and cable clamp onto the swing arm using the bolt.

Connect the brake torque link to the swing arm using the lock washer and nut ('85 ONLY).

TORQUE: 8–11 N·m (0.8–1.1 kg-m, 6–8 ft-lb)

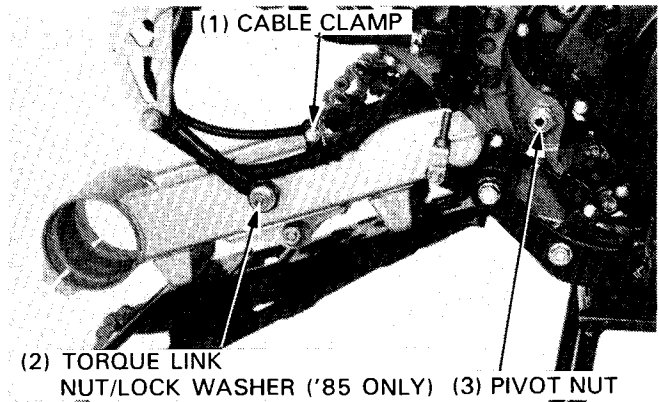

Connect the shock bracket to the swing arm and tighten the bolts.

TORQUE: 40–50 N·m (4.0–5.0 kg-m, 29–36 ft-lb)

Install the following:

- rear wheel bearing holder (page 12-10)
- rear axle (page 12-6)
- rear wheels (page 12-3).

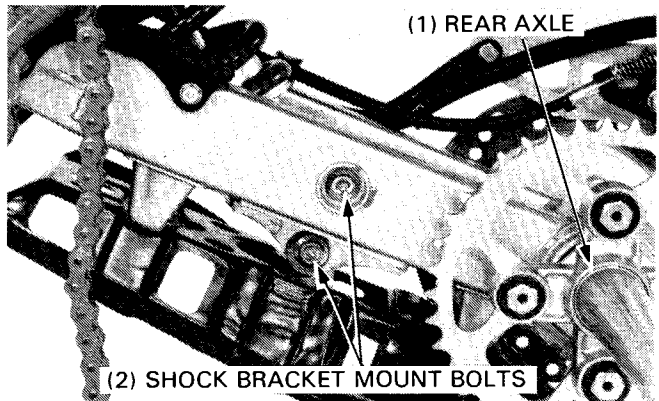

MEMO

HYDRAULIC BRAKES

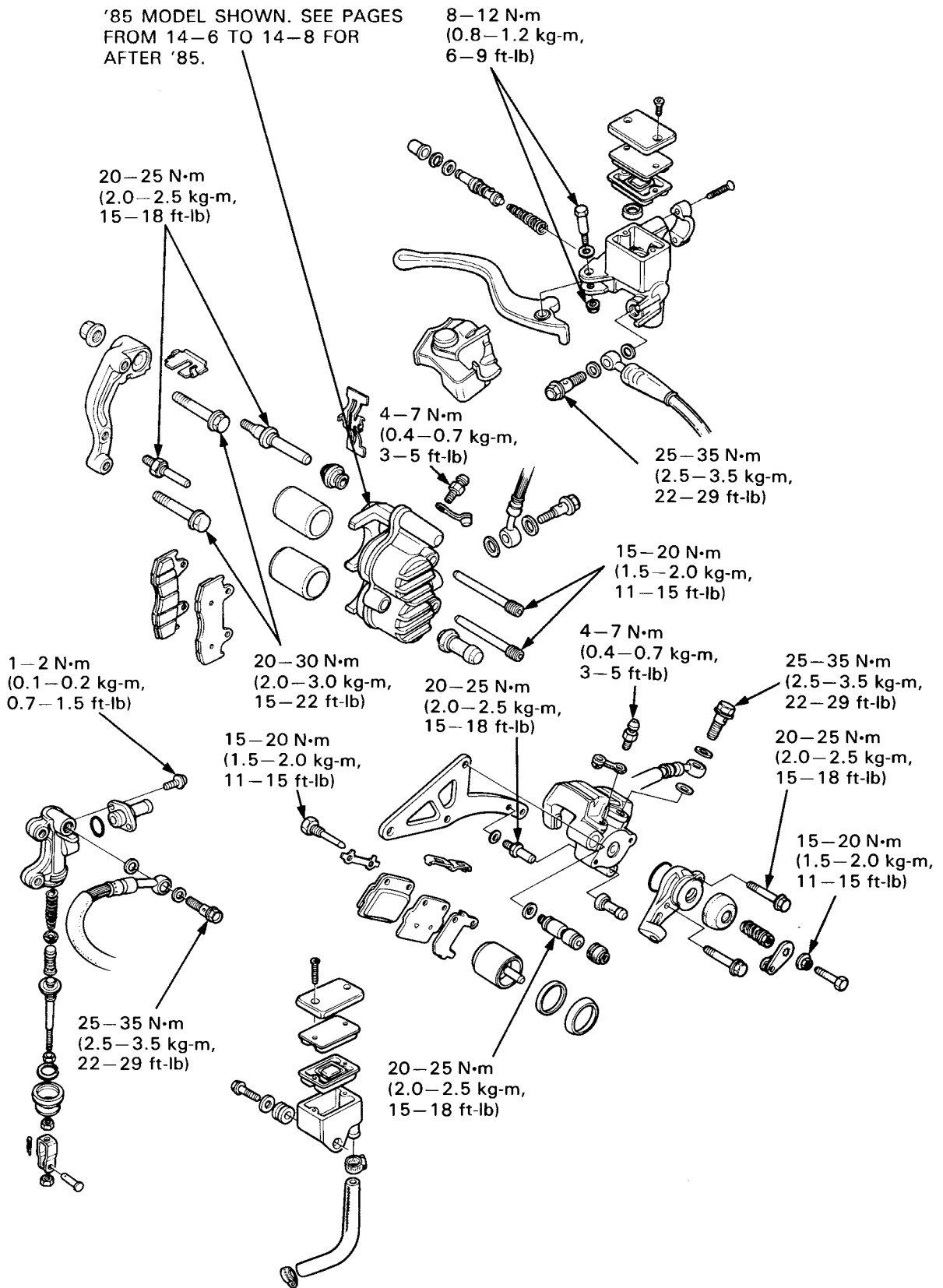

14. HYDRAULIC BRAKES

SERVICE INFORMATION	14-1	FRONT CALIPER	14-11
TROUBLESHOOTING	14-2	REAR CALIPER	14-14
BRAKE FLUID REPLACEMENT/ BLEEDING	14-3	FRONT MASTER CYLINDER	14-19
BRAKE PAD REPLACEMENT	14-6	REAR MASTER CYLINDER	14-21
BRAKE DISC	14-10	REAR BRAKE PEDAL	14-23

SERVICE INFORMATION

GENERAL

- The front and rear brakes can be removed without disconnecting the hydraulic system.
- Once the hydraulic systems have been opened, or if the brakes feel spongy, the system must be bled.
- Do not allow foreign material to enter the system when filling the reservoir.
- Brake fluid will damage painted, plastic, and rubber parts. Whenever handling brake fluid, protect the painted, plastic, and rubber parts by covering them with a rag. If fluid does get on these parts, wipe it off with a clean cloth.
- Always check brake operation before riding the ATC.

SPECIFICATIONS

ITEM		STANDARD	SERVICE LIMIT
Front disc	Thickness	3.8–4.2 mm (0.15–0.17 in)	3.0 mm (0.12 in)
	Runout	—	0.30 mm (0.012 in)
Front master cylinder	Cylinder I.D.	12.700–12.743 mm (0.5000–0.5017 in)	12.755 mm (0.5022 in)
	Piston O.D.	12.657–12.684 mm (0.4983–0.4994 in)	12.645 mm (0.4978 in)
Front caliper	Piston O.D.	25.300–25.350 mm (0.9960–0.9980 in)	25.30 mm (0.996 in)
	Cylinder I.D.	25.400–25.450 mm (1.0000–1.0020 in)	25.46 mm (1.002 in)
Rear disc	Thickness	3.8–4.2 mm (0.15–0.17 in)	3.0 mm (0.12 in)
	Runout	—	0.30 mm (0.012 in)
Rear master cylinder	Cylinder I.D.	12.700–12.743 mm (0.5000–0.5017 in)	12.755 mm (0.5022 in)
	Piston O.D.	12.657–12.684 mm (0.4983–0.4994 in)	12.645 mm (0.4978 in)
Rear caliper	Cylinder I.D.	33.960–34.010 mm (1.3370–1.3390 in)	34.020 mm (1.3394 in)
	Piston O.D.	33.878–33.928 mm (1.3338–1.3357 in)	33.870 mm (1.3335 in)

HYDRAULIC BRAKES

TORQUE VALUES

Air bleed valves	4–7 N•m (0.4–0.7 kg-m, 3–5 ft-lb)
Caliper mounting bolts	20–30 N•m (2.0–3.0 kg-m, 15–22 ft-lb)
Brake pad pin bolts	15–20 N•m (1.5–2.0 kg-m, 11–15 ft-lb)
Brake disc mounting bolts	37–43 N•m (3.7–4.3 kg-m, 27–31 ft-lb)
Oil bolts	25–35 N•m (2.5–3.5 kg-m, 18–25 ft-lb)
Rear caliper socket bolt	20–25 N•m (2.0–2.5 kg-m, 15–18 ft-lb)
Parking brake base bolts	20–25 N•m (2.0–2.5 kg-m, 15–18 ft-lb)
Parking brake adjusting lock nut	15–20 N•m (1.5–2.0 kg-m, 11–15 ft-lb)
Brake torque link-to-caliper bracket bolt ('85)	24–30 N•m (2.4–3.0 kg-m, 17–22 ft-lb)
Front brake lever pivot bolt and nut	8–12 N•m (0.8–1.2 kg-m, 6–9 ft-lb)
Rear reservoir hose joint screws	1–2 N•m (0.1–0.2 kg-m, 0.7–1.5 ft-lb)

TOOL

Special

Snap ring pliers 07914–3230001

TROUBLESHOOTING

Brake lever/pedal soft or spongy

- Air bubbles in hydraulic system.
- Low fluid level.
- Hydraulic system leaking.

Brake lever/pedal too hard

- Sticking piston(s).
- Clogged hydraulic system.
- Pads glazed or worn excessively.

Brake drags

- Hydraulic system sticking.
- Sticking piston(s).

Brakes grab

- Pads contaminated.
- Disc or wheel misaligned.

Brake chatter or squeal

- Pads contaminated.
- Excessive disc runout.
- Caliper installed incorrectly.
- Disc or wheel misaligned.

BRAKE FLUID REPLACEMENT/BLEEDING

BRAKE FLUID DRAINING

WARNING

- *A contaminated brake disc or pad reduces stopping power. Discard contaminated pads and clean a contaminated disc with a high quality brake degreasing agent.*

CAUTION

- *Do not allow foreign material to enter the system when filling the reservoir.*
- *Avoid spilling fluid on painted, plastic, or rubber parts. Place a rag over these parts whenever the system is serviced.*

With the fluid reservoir parallel to the ground, remove the reservoir cover and diaphragm.

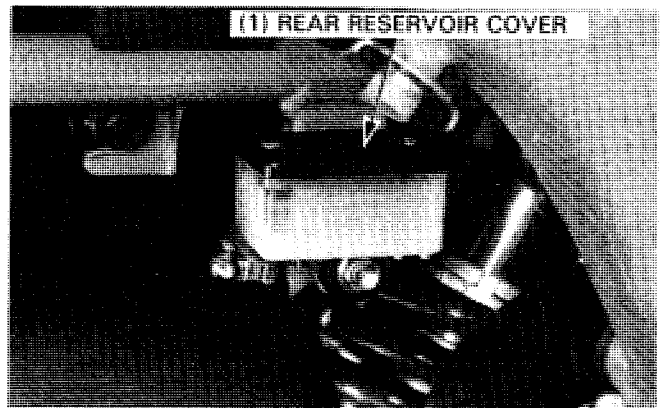
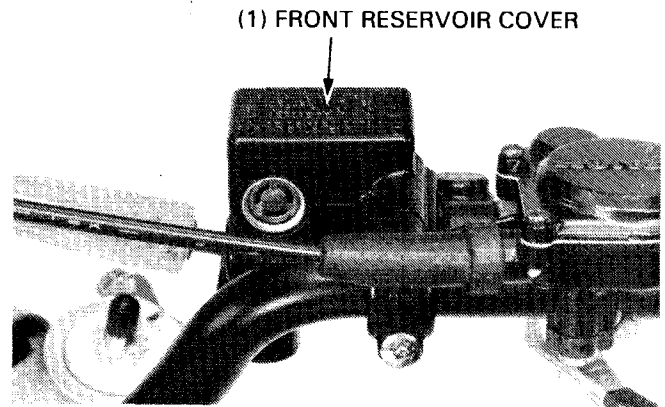

Connect a hose to the bleed valve.

Loosen the caliper bleed valve and pump the brake lever (or pedal) until no more fluid flows out of the bleed valve.

Close the bleed valve.

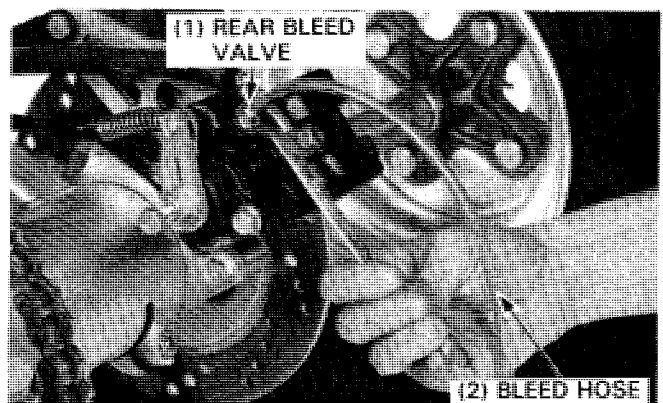
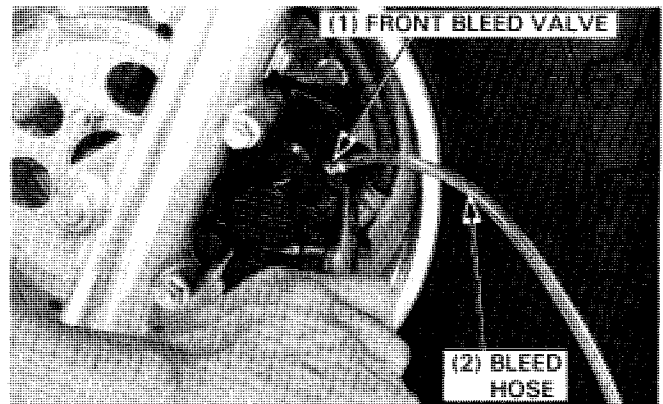

HYDRAULIC BRAKES

BRAKE FLUID FILLING/BLEEDING

Fill the reservoir with DOT-3 or 4 brake fluid from a sealed container.

CAUTION

- *Do not mix different types of fluid. They are not compatible.*

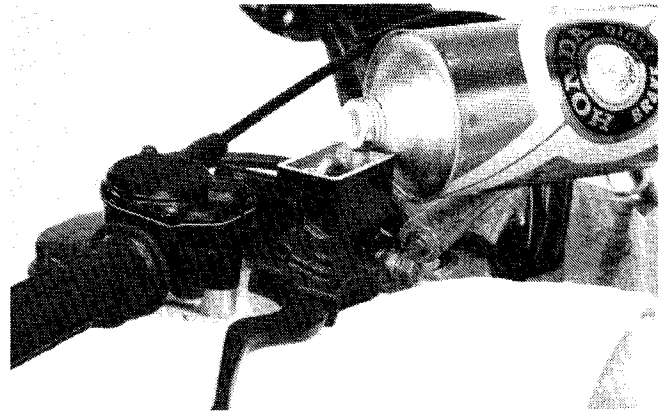

Connect the commercially available brake bleeder to the bleed valve.

Pump the brake bleeder and loosen the bleed valve. Add fluid when the fluid level in the master cylinder reservoir is low.

NOTE

- Check the fluid level often while bleeding the brakes to prevent air from being pumped into the system.
- When using a brake bleeding tool, follow the manufacturer's operating instructions.

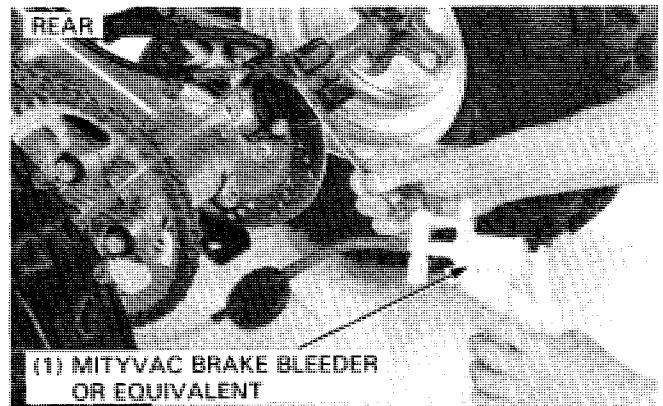
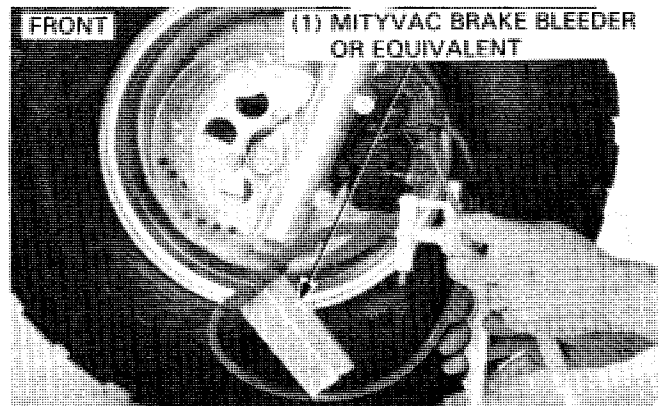

Repeat the above procedures until air bubbles do not appear in the plastic hose.

NOTE

- If air is entering the bleeder from around the bleed valve threads, seal the threads with teflon tape.

Close the bleed valve and operate the brake lever or pedal. If it feels spongy, repeat the BLEEDING procedure.

If a brake bleeder is not available, perform the following procedure:

Pump up the system pressure with the lever (or pedal) until there are no air bubbles in the fluid flowing out of the reservoir small hole and lever resistance is felt.

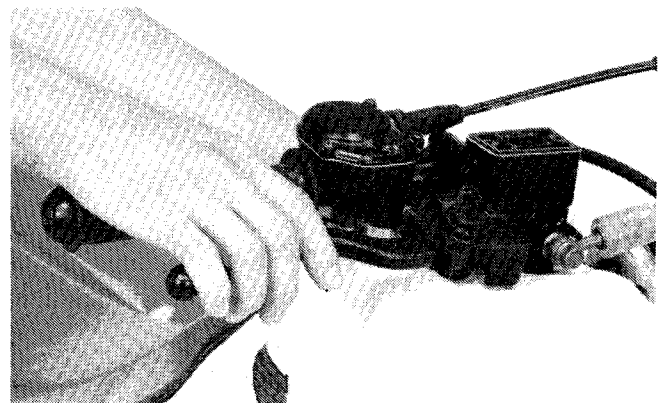

1. Squeeze the brake lever (or depress the brake pedal), open the bleed valve 1/2 turn and then close the valve.

NOTE

- Do not release the brake lever (or pedal) until the bleed valve has been closed.

2. Release the brake lever (or pedal) slowly and wait several seconds after it reaches the end of its travel.

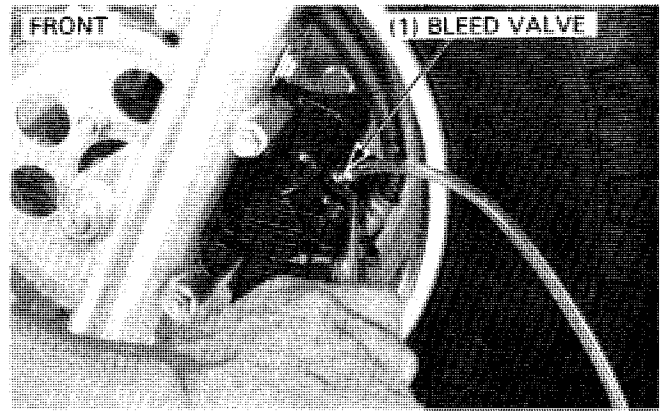

Repeat steps 1 and 2 until bubbles cease to appear in the fluid coming out of the bleed valve.
Tighten the bleed valve.

TORQUE: 4–7 N·m (0.4–0.7 kg-m, 3–5 ft-lb)

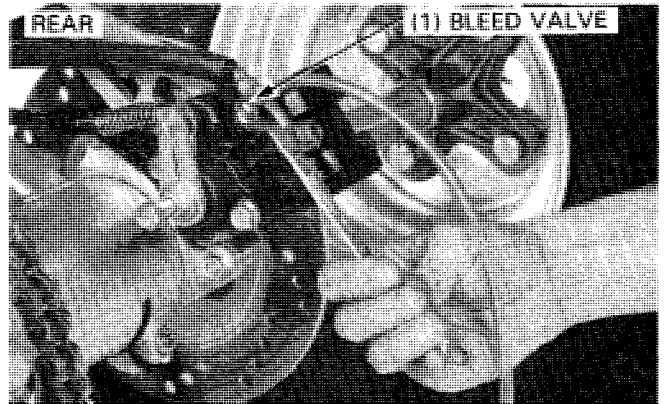

Fill the fluid reservoir to the upper level mark.

Reinstall the diaphragm and master cylinder cover.

WARNING

- *A contaminated brake disc or pad reduces stopping power. Discard contaminated pads and clean a contaminated disc with a high quality brake degreasing agent.*

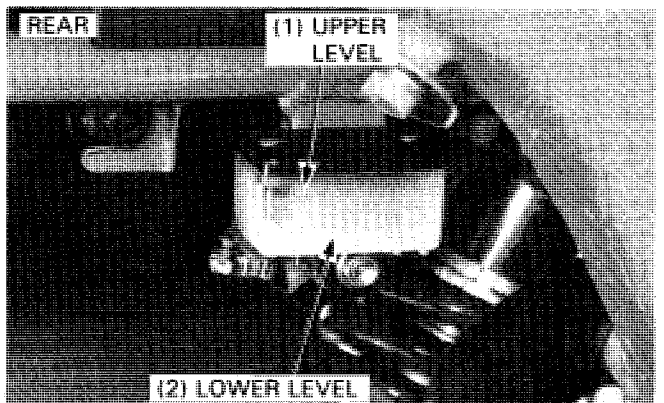
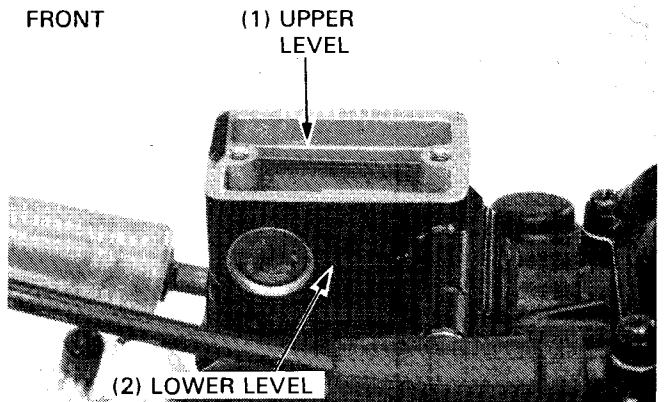

HYDRAULIC BRAKES

BRAKE PAD REPLACEMENT

NOTE

- Always replace the brake pads in pairs to assure even disc pressure.
- Always use new pads with marks "N18FF" (FRONT) and "TT2202FF" ('85: REAR) or "N18FF" (After '85: REAR) on the pads.

FRONT BRAKE

'85 only:

Raise the front wheel off the ground by placing a block or safety stand under the skid plate.

Remove the wheel nuts.

'85 and after:

Remove the pad pin bolt plugs from the caliper.
Loosen the pad pin bolts.

Remove the front caliper mounting bolts.

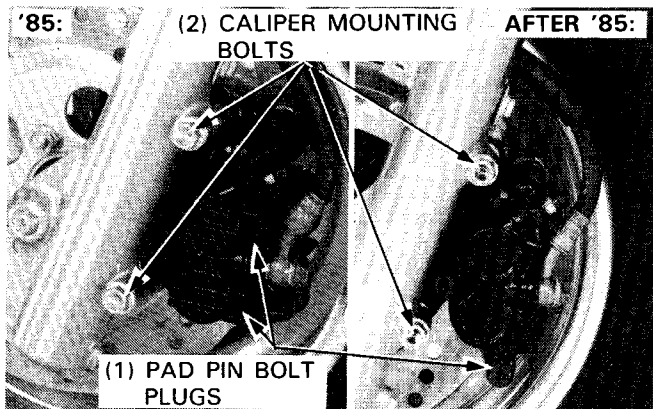
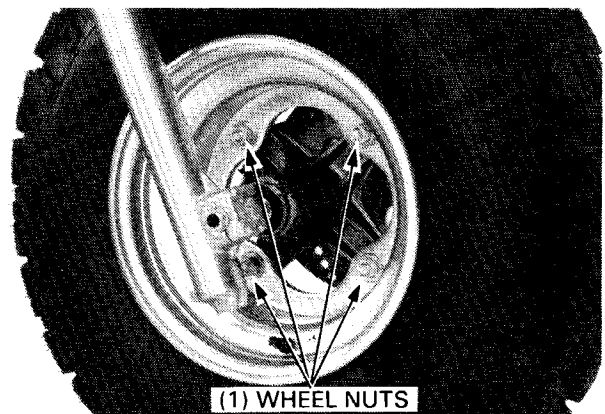

Remove the pad pin bolts and brake pads.

Remove the caliper bracket from the caliper.

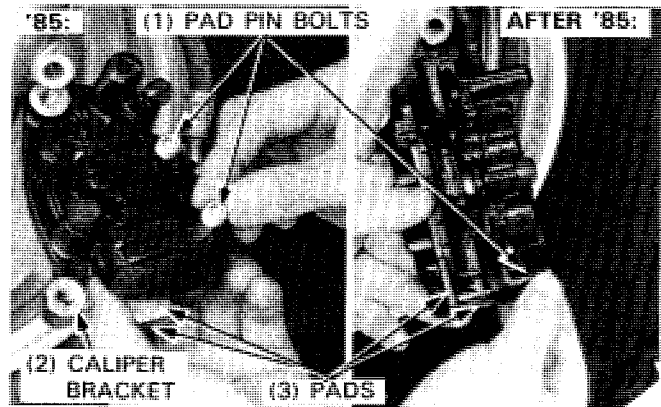

Make sure that the pad spring and retainer clip are installed in the position shown.

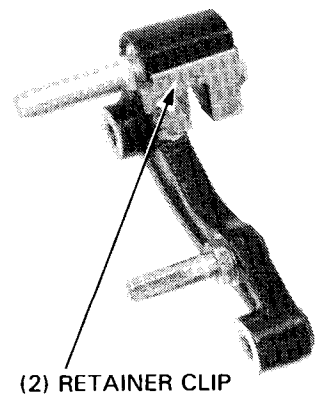
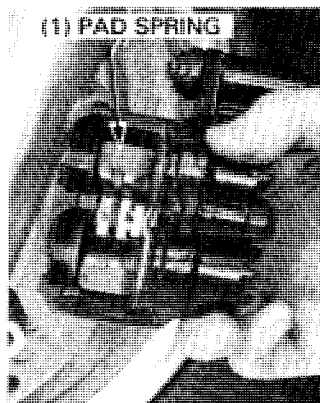

Apply silicone grease to the caliper bracket pins and the caliper boots and insert the pins into the boots.

CAUTION

- *Slide the boot into the groove of the caliper bracket pins.*

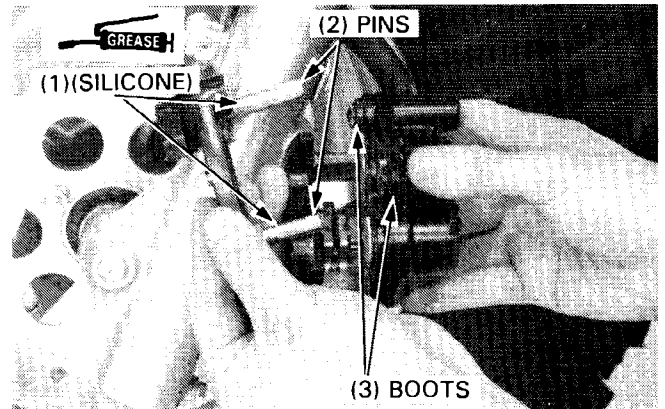

Install new brake pads and the pad pins.

NOTE

- Always use new pads with mark "N18FF" on the pad.

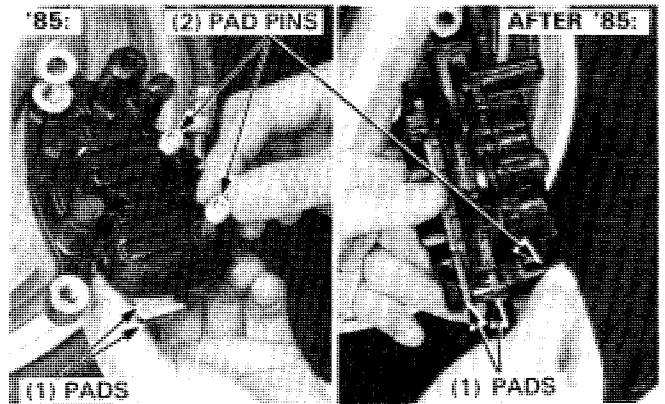

Push the caliper pistons in all the way.

CAUTION

- *Be careful that the master cylinder does not overflow when the caliper pistons are compressed.*
- *Brake fluid can cause damage to painted, plastic, or rubber surfaces.*

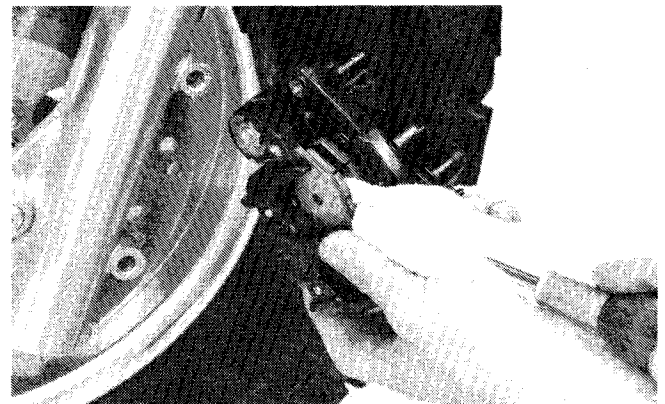

Install the caliper to the front fork so the disc is positioned between the pads, being careful not to damage the pads. Tighten the caliper mounting bolts.

TORQUE: 20–30 N·m (2.0–3.0 kg·m, 15–22 ft·lb)

Tighten the pad pin bolts.

TORQUE: 15–20 N·m (1.5–2.0 kg·m, 11–15 ft·lb)

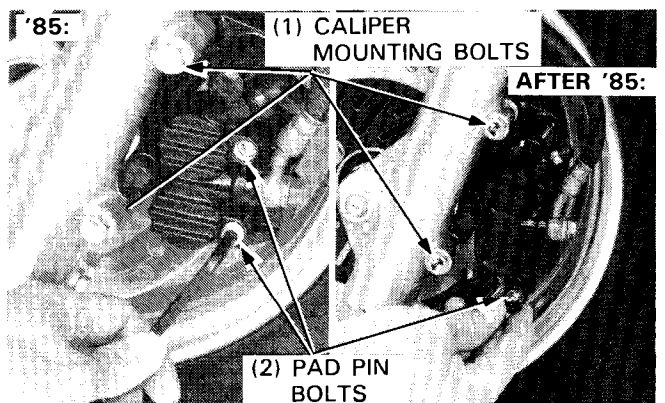

HYDRAULIC BRAKES

Install the pad pin bolt plugs and tighten them securely.

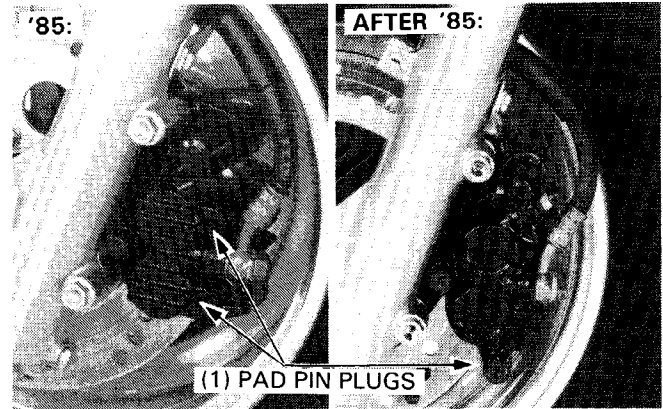

'85 only:

Install the front wheel nuts.

TORQUE: 60–70 N·m (6.0–7.0 kg-m, 43–51 ft-lb)

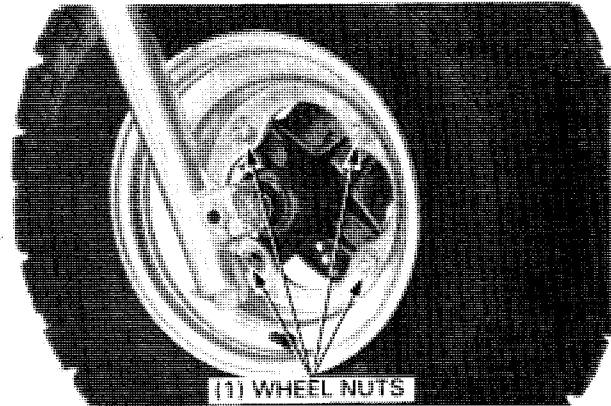

REAR BRAKE

Remove the seat/rear fender.

Bend down the lock washer tabs and loosen the pad pin bolts.

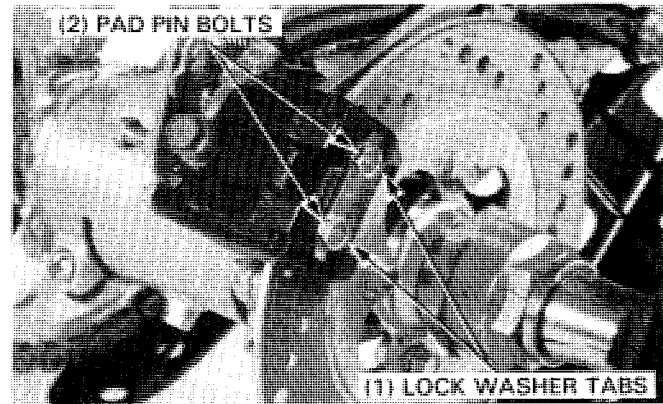

Remove the caliper mounting bolts and raise the caliper up.

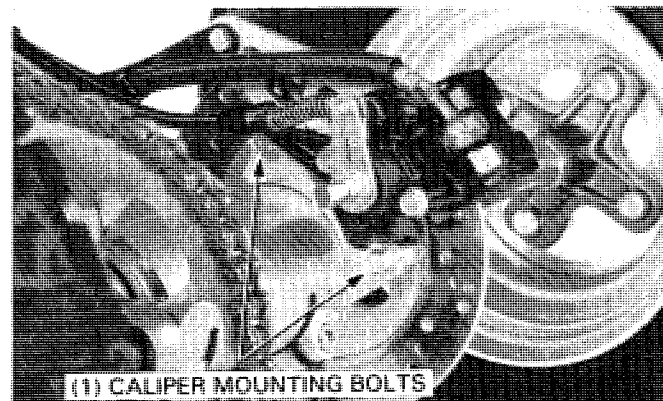

Remove the pad pin bolts, brake pads and pad shim.

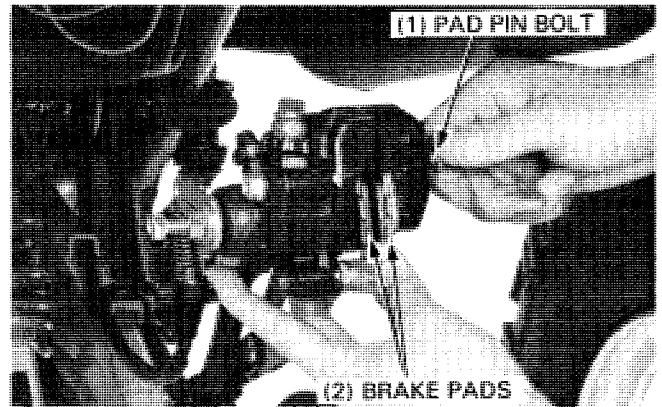

Make sure the pad spring is installed in place as shown.

Install new pads in the caliper.

Install the pad shim onto the new inside pad.

NOTE

- Always use new pads with marked "TT2202FF" ('85) or "N18FF" (After '85).

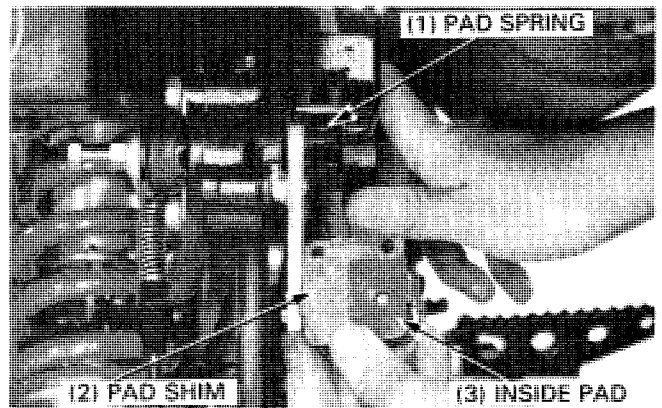

Align the pad pin bolt holes by depressing the pads against the caliper, and install the pad pin bolts.

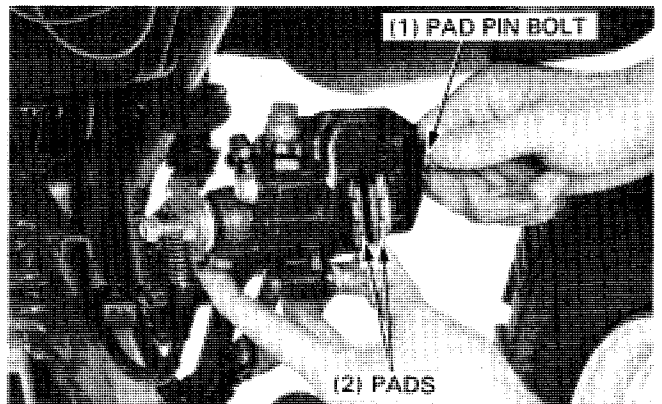

Push the caliper piston in all the way, being careful not to damage the pads.

CAUTION

- *Be careful that the master cylinder does not overflow when the caliper pistons are compressed.*
- *Brake fluid can cause damage to painted, plastic, or rubber surfaces.*



HYDRAULIC BRAKES

Lower the caliper so the disc is positioned between the pads, being careful not to damage the pads.
Install and tighten the caliper mounting bolts.

TORQUE: 20–30 N·m (2.0–3.0 kg-m, 15–22 ft-lb)

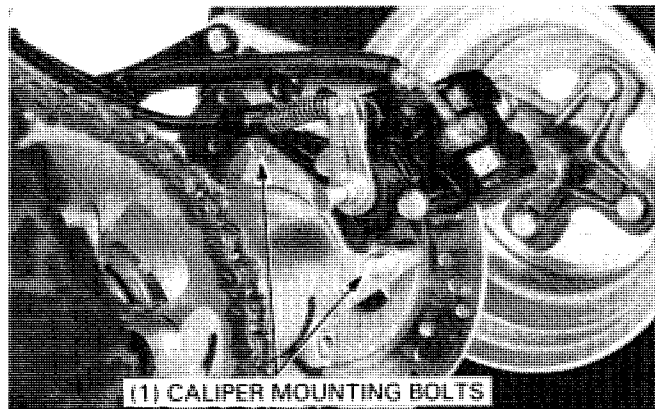

Tighten the pad pin bolts using a new lock washer.

TORQUE: 15–20 N·m (1.5–2.0 kg-m, 11–15 ft-lb)

Bend up the lock washer tabs against the bolt heads.

Adjust the parking brake (page 3-13).
Install the seat/rear fender.

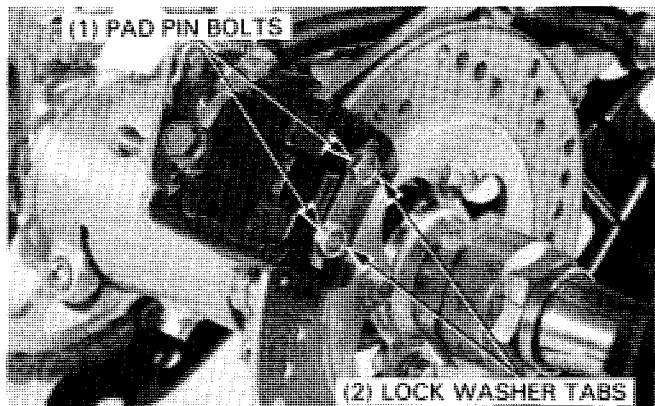

BRAKE DISC

THICKNESS INSPECTION

Measure the brake disc thickness with a micrometer.

SERVICE LIMIT:

FRONT: 3.0 mm (0.12 in)

REAR: 3.0 mm (0.12 in)

Replace a disc that is worn beyond the service limit.

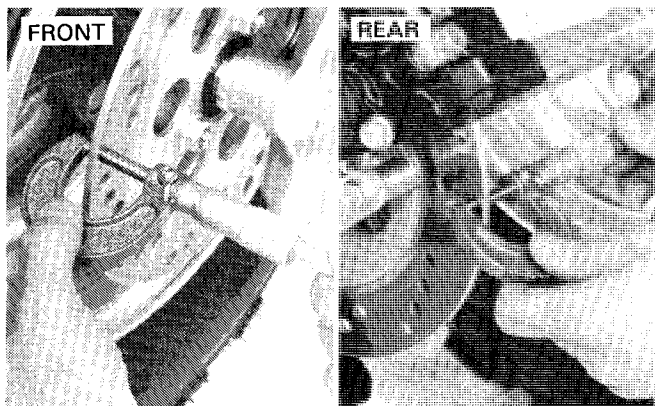

FRONT BRAKE DISC REPLACEMENT

Refer to page 11-7 and 11-8 for front brake disc removal and installation.

REAR BRAKE DISC REPLACEMENT

Remove the right rear wheel and wheel hub (page 12-3).
Remove the caliper mount bolts and raise the caliper up.

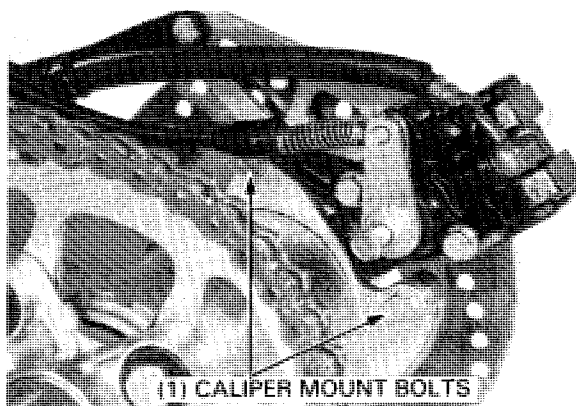

Loosen the inner axle lock nut (page 12-4).

Remove the disc mount bolts and disc from the disc hub.

Install a new disc on the hub with its "DRIVE" arrow mark facing right.

Tighten the disc mount bolts.

TORQUE: 37–43 N·m (3.7–4.3 kg-m, 27–31 ft-lb)

Tighten the inner axle lock nut (page 12-7).

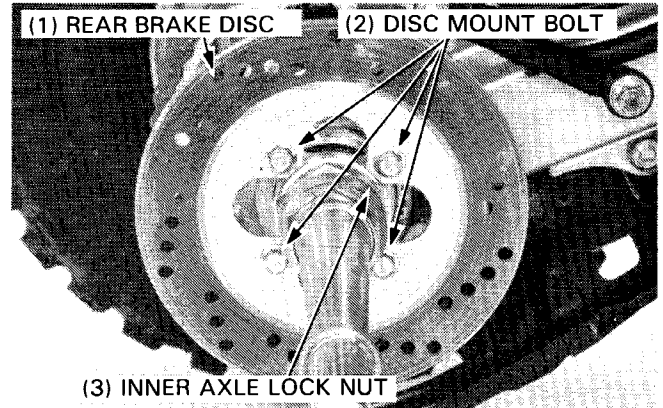

Lower the caliper and tighten the caliper mount bolts.

TORQUE: 20–30 N·m (2.0–3.0 kg-m, 14–22 ft-lb)

Install the right wheel hub (page 12-8) and wheel (page 12-3).

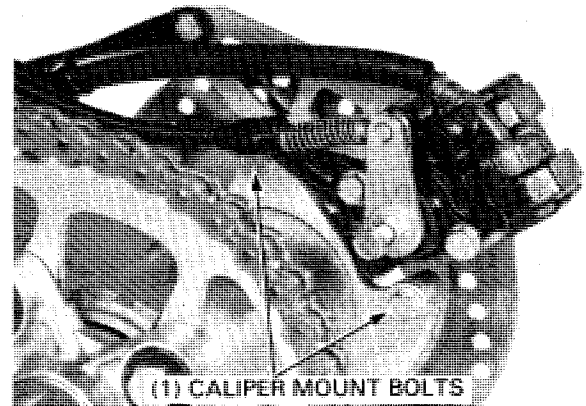

DISC WARPAGE INSPECTION

Measure the each disc for warpage.

SERVICE LIMIT: 0.30 mm (0.012 in)

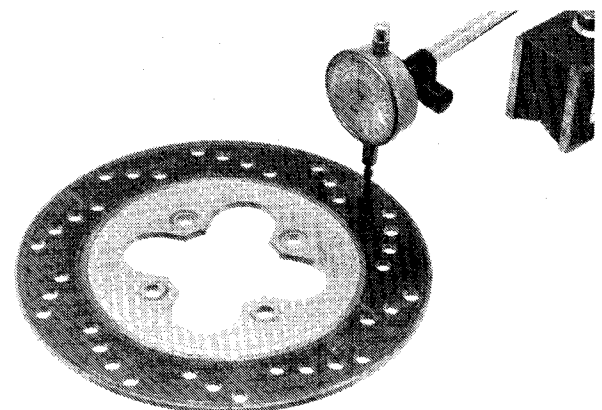

FRONT CALIPER

REMOVAL

Drain the brake fluid from the front hydraulic system.
Remove the oil bolt and brake hose from the caliper.

CAUTION

- *Avoid spilling fluid on painted, plastic, or rubber parts. Place a rag over these parts whenever the system is serviced.*

Remove the caliper mounting bolts and the caliper from the fork leg.

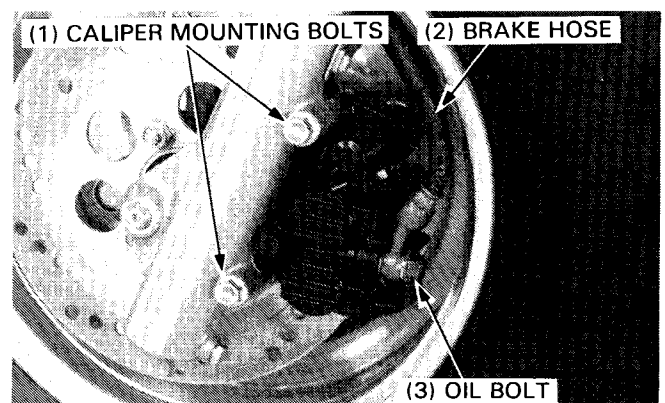

HYDRAULIC BRAKES

DISASSEMBLY

Remove the pad pin bolts and pads.
Remove the caliper bracket from the caliper.

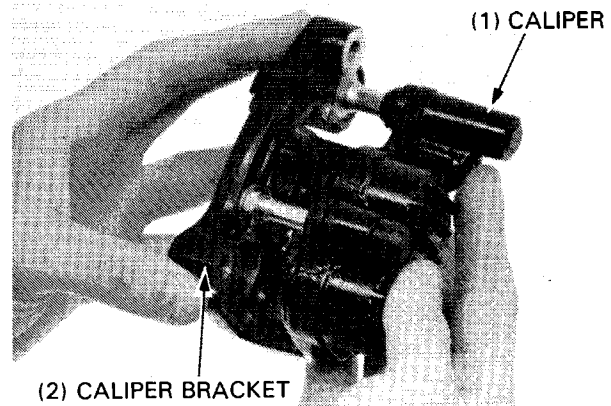

Remove the pad spring and caliper pivot boots.

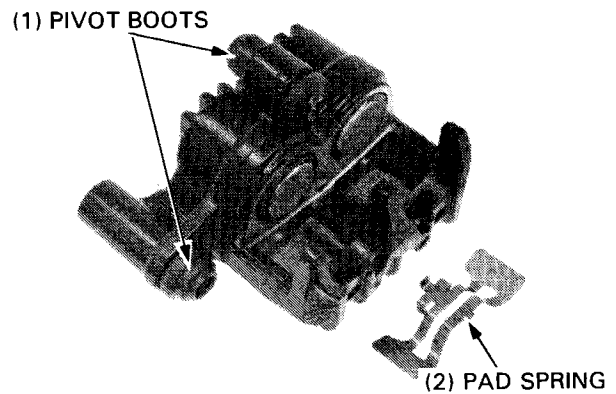

Position the caliper with the pistons down and apply small squirts of air pressure to the fluid inlet to remove the pistons.

WARNING

- *Do not use high pressure air or bring the nozzle too close to the inlet.*
- *Place a shop towel over the piston to prevent the piston from becoming a projectile.*

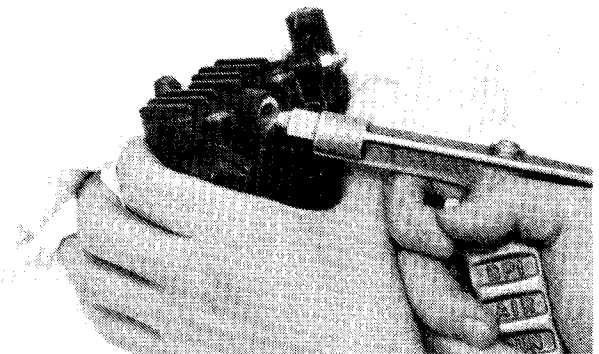

Push the dust and piston seals in and lift them out.
Clean the seal grooves with clean brake fluid.

CAUTION

- *Be careful not to damage the piston sliding surfaces.*

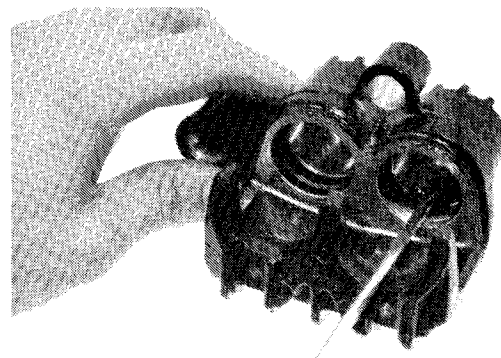

INSPECTION

Check the caliper cylinders and pistons for scratches, scoring or other damage.

Measure the cylinder inside diameter and piston outside diameter.

SERVICE LIMITS:

CYLINDER I.D.: 25.46 mm (1.002 in)

PISTON O.D.: 25.30 mm (0.996 in)

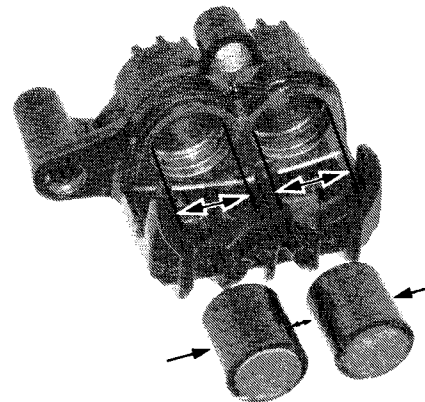

ASSEMBLY

Coat new dust and piston seals with clean brake fluid and install them in the seal grooves in the caliper with their smaller diameter ends facing in.

Lubricate the cylinders and pistons with clean brake fluid and install the pistons into the cylinders with the piston pad end facing the pad side.

Apply silicone grease to the pivot collar and boots and install the boots making sure that they are seated in the caliper grooves properly.

Install the pad spring.

Coat the pins with silicone grease and install the caliper bracket on the caliper.

Install the front brake pads (page 14-7).

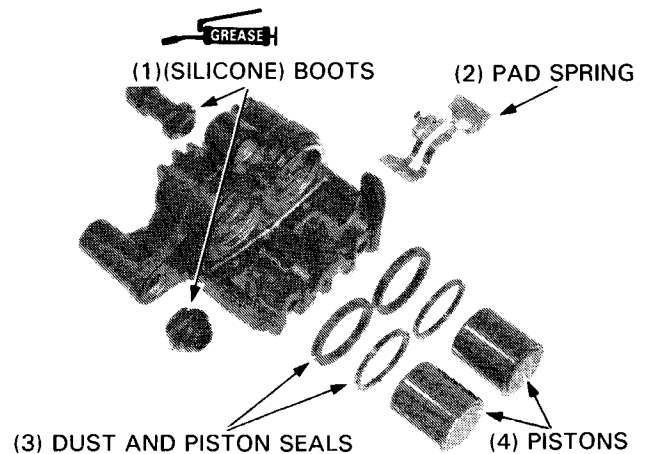

CAUTION

- *Slide the boots into the grooves of the caliper bracket pins.*

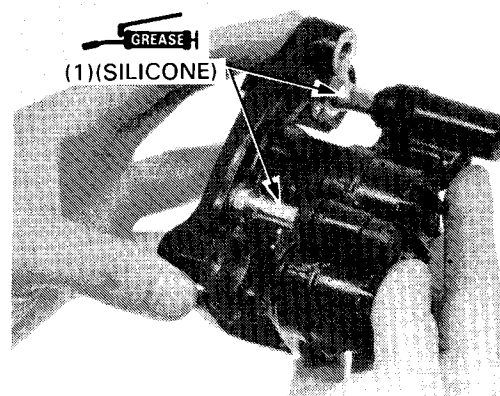

Install the caliper onto the left fork leg and tighten the caliper mounting bolts.

TORQUE: 20–30 N·m (2.0–3.0 kg·m, 15–22 ft·lb)

Connect the front brake hose to the caliper with the oil bolt and two new sealing washers, and tighten the oil bolt.

TORQUE: 25–35 N·m (2.5–3.5 kg·m, 18–25 ft·lb)

Fill the front brake reservoir and bleed the front brake system (page 14-4).

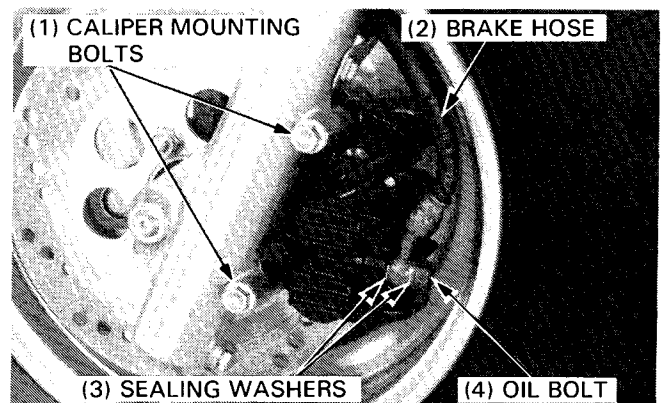

HYDRAULIC BRAKES

REAR CALIPER

REMOVAL

Drain the brake fluid from the rear hydraulic system.

Remove the oil bolt and brake hose from the rear caliper.

CAUTION

- *Avoid spilling fluid on painted, plastic, or rubber parts. Place a rag over these parts whenever the system is serviced.*

Disconnect the parking brake cable from the arm on the caliper.

Disconnect the brake torque link from the caliper bracket by removing the nut and bolt ('85 only).

Remove the caliper mount bolts and the caliper.

DISASSEMBLY

Remove the brake pads (page 14-8).

Loosen the socket bolt and remove the caliper bracket from the caliper.

Remove the pad spring, pivot boots and socket bolt.

Position the caliper with the piston down and apply small squirts of air pressure to the fluid inlet to remove the piston.

WARNING

- *Do not use high pressure air or bring the nozzle too close to the inlet.*
- *Place a shop towel over the piston to prevent the piston from becoming a projectile.*

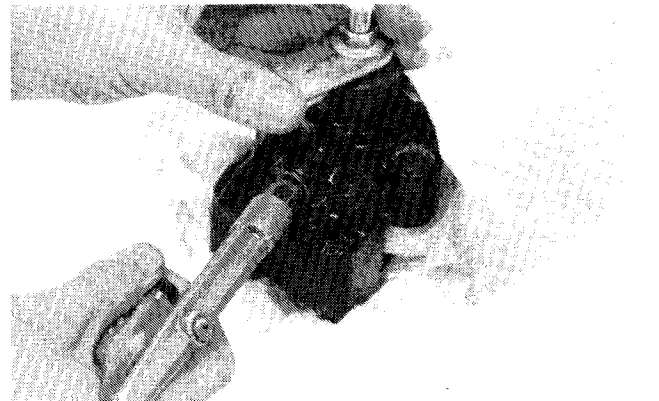
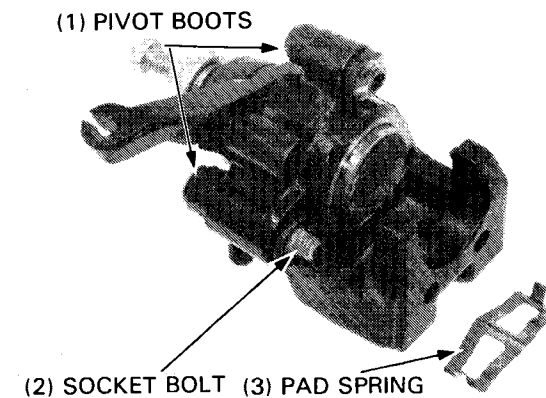
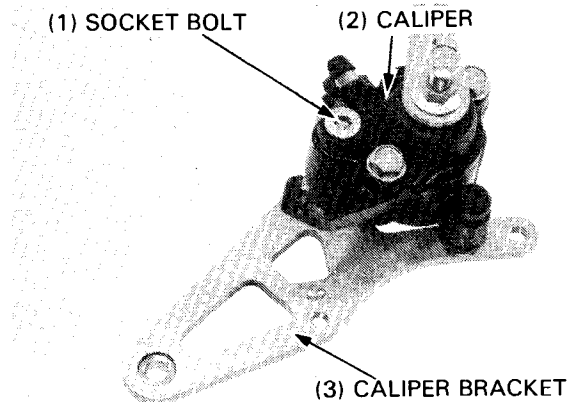
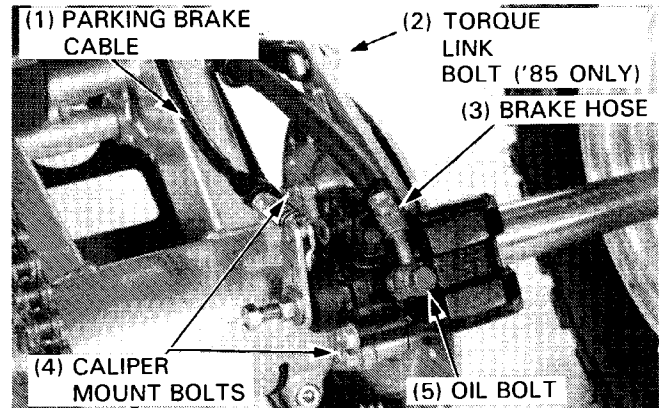

Push the dust and piston seals in and lift them out.
Clean the seal grooves with clean brake fluid.

CAUTION

- *Be careful not to damage the piston sliding surface.*

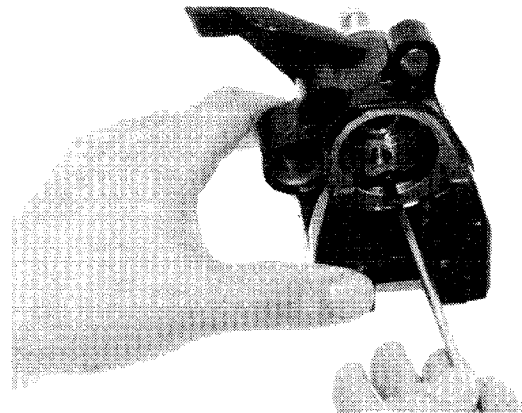

INSPECTION

Check the caliper cylinder and piston for scratches, scoring or other damage.

Measure the cylinder inside diameter and piston outside diameter.

SERVICE LIMITS:

CYLINDER I.D.: 34.020 mm (1.3394 in)

PISTON O.D.: 33.870 mm (1.3335 in)

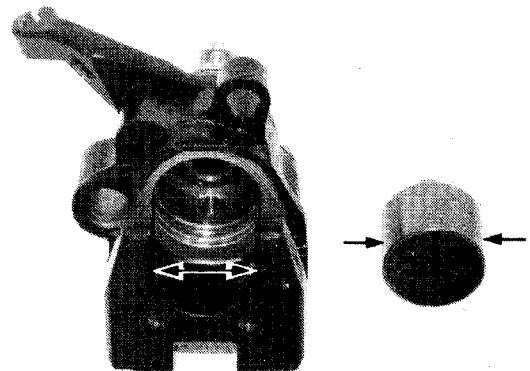

ASSEMBLY

Coat new dust and piston seals with clean brake fluid and install them in the seal groove in the caliper with their small diameter ends facing in.

Lubricate the cylinder and piston with brake fluid, and install the piston with the piston pad end facing the pad.

Apply silicone grease to the socket bolt and boots. Install the bolt and boots making sure that the boots are seated in the bolt and caliper grooves properly.

Install the pad spring, pads and pad pin bolts (page 14-9).

Apply silicone grease to the pin on the caliper bracket and install the bracket onto the caliper.

Tighten the socket bolt.

TORQUE: 20–25 N·m (2.0–2.5 kg·m, 15–18 ft·lb)

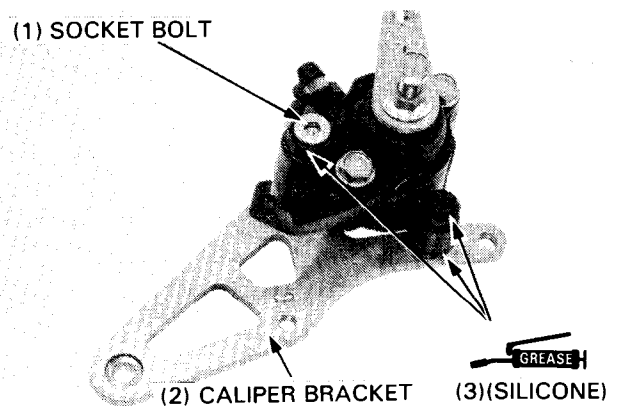
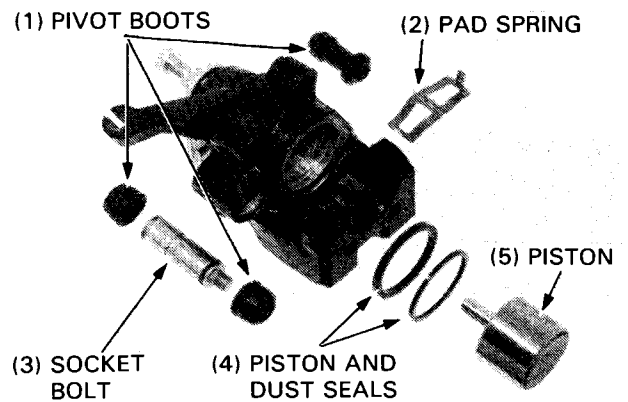

HYDRAULIC BRAKES

PARKING BRAKE MECHANISM

Loosen the lock nut and remove the adjusting bolt and arm.

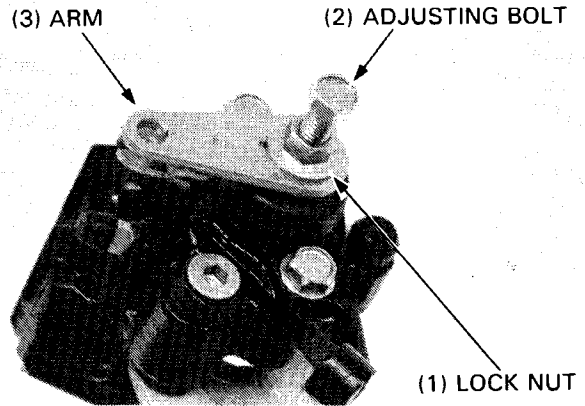

Remove the parking brake attaching bolts and parking brake from the caliper.

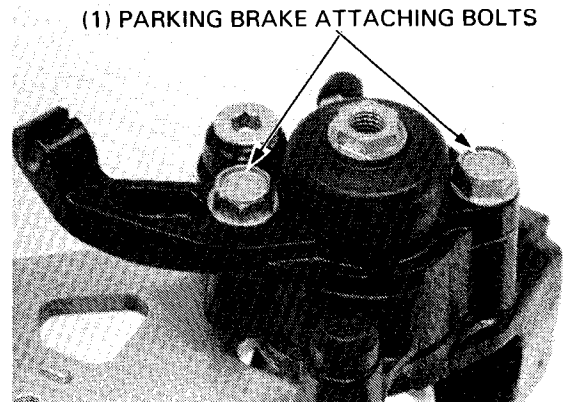

Remove the boot and parking brake shaft from the brake base.

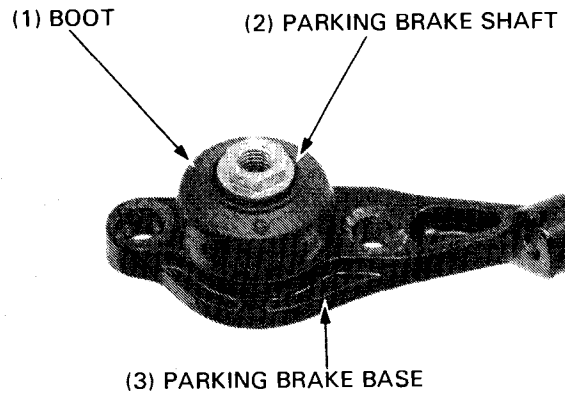

Check the boot for deterioration or damage.
Check the shaft and base threads for wear or damage.

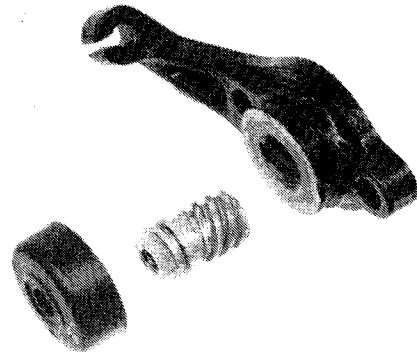

Apply grease to the shaft, align the punch marks on the base and shaft and screw in the shaft fully.

Make sure that the punch marks are aligned.

NOTE

- The parking brake shaft has left hand threads.

Screw out the parking brake shaft 1/8 turn.

(1) PUNCH MARKS

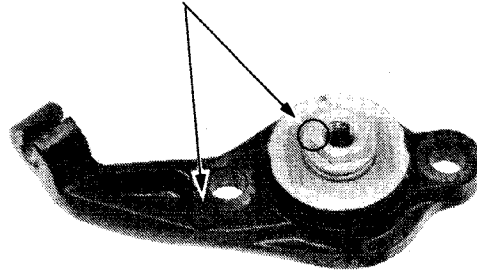

Install the boot over the shaft and base, making sure that the boot is seated in the groove in the shaft and base properly.

(1) BOOT

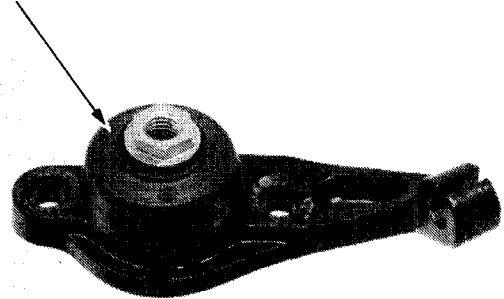

Install a new O-ring in the groove in the base and install the base onto the caliper.

(1) BASE

(2) O-RING

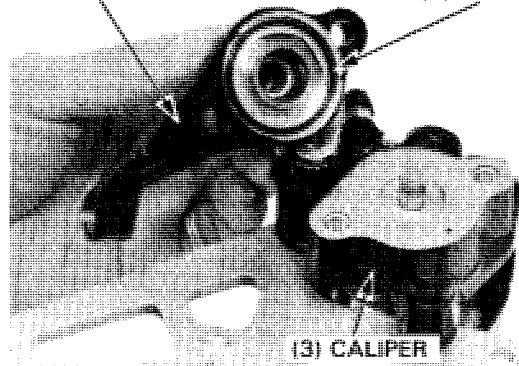

(3) CALIPER

Tighten the bolts.

TORQUE: 20–25 N·m (2.0–2.5 kg·m, 14–18 ft·lb)

(1) BOLTS

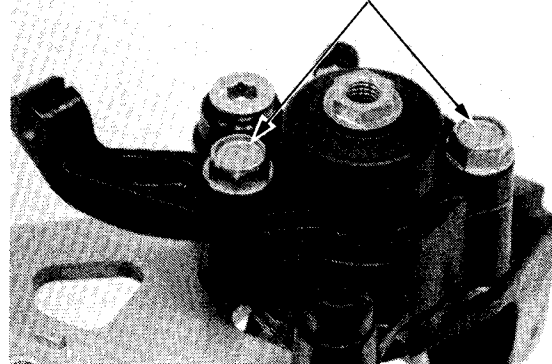

HYDRAULIC BRAKES

Install the parking brake arm onto the shaft, aligning the punch marks.

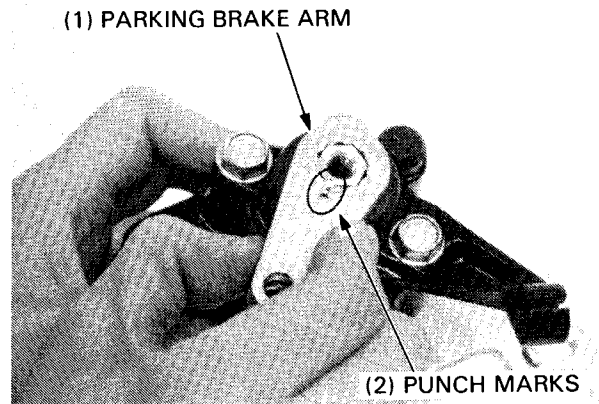

Temporarily install the parking brake adjusting bolt and lock nut.

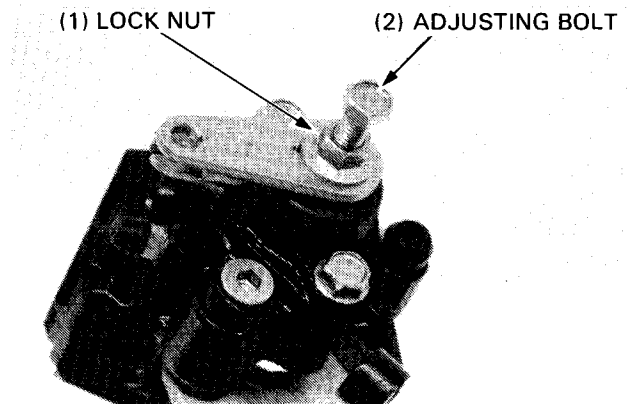

INSTALLATION

Place the caliper over the brake disc being careful not to damage the pads.

Connect the caliper bracket to the brake torque link using the bolt and nut ('85 only).

TORQUE: 24–30 N·m (2.4–3.0 kg-m, 17–22 ft-lb)

Install the caliper mounting bolts and tighten them.

TORQUE: 20–30 N·m (2.0–3.0 kg-m, 15–22 ft-lb)

Connect the parking brake cable to the brake arm.

Connect the rear brake hose using the oil bolt and two sealing washers after making sure that the sealing washers are in good condition.

Tighten the oil bolt.

TORQUE: 25–35 N·m (2.5–3.5 kg-m, 18–25 ft-lb)

Fill and bleed the rear brake system (page 14-4).

Adjust the parking brake (page 3-14).

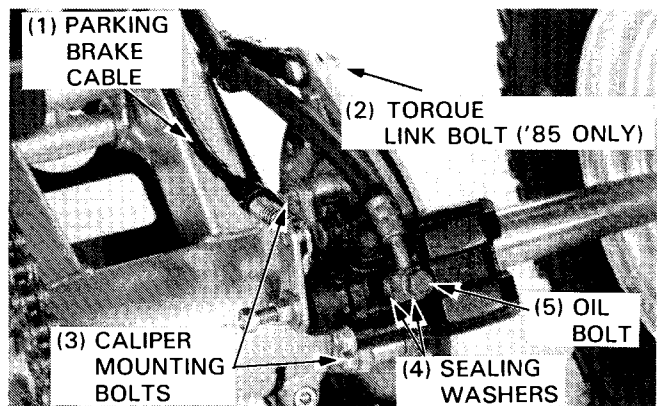

FRONT MASTER CYLINDER

REMOVAL

Drain brake fluid from the front hydraulic system.

Remove the front brake lever and disconnect the brake hose from the master cylinder.

CAUTION

- *Avoid spilling fluid on painted, plastic, or rubber parts. Place a rag over these parts whenever the system is serviced.*
- *When removing the oil bolt, cover the end of the hose to prevent contamination.*

Loosen the throttle housing holder screws and remove the housing.

Remove the master cylinder holder screws and the master cylinder.

DISASSEMBLY

Slide back the rubber cover and remove the brake lever by removing the pivot nut and bolt.

Remove the piston boot and the snap ring from the master cylinder body.

Remove the piston and spring from the master cylinder.

Clean the master cylinder, reservoir and piston in clean brake fluid.

INSPECTION

Check the primary and secondary cups for wear, deterioration or damage.

Check the master cylinder and piston for scratches, scoring or other damage.

Measure the master cylinder inside diameter and the piston outside diameter.

SERVICE LIMITS:

MASTER CYLINDER I.D.: 12.755 mm (0.5022 in)
PISTON O.D.: 12.645 mm (0.4978 in)

NOTE

- The piston, piston cups and spring must be replaced as a set.

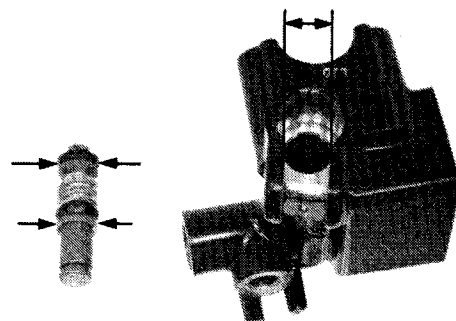
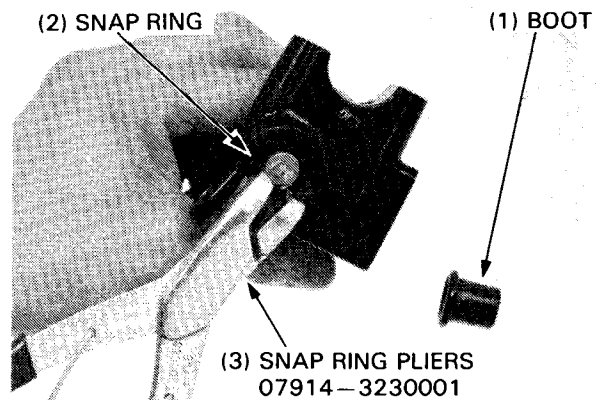
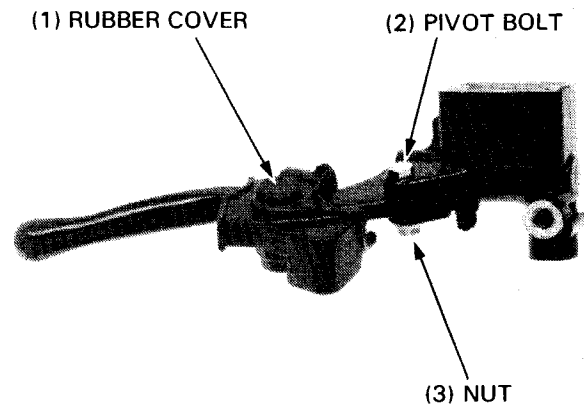
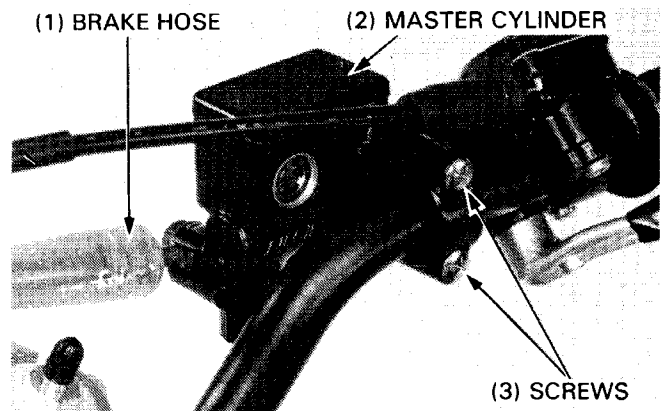

HYDRAULIC BRAKES

ASSEMBLY

Coat the piston, primary and secondary cups with clean brake fluid, then install the piston spring and piston.

Install the snap ring.

CAUTION

- Do not allow the lips of the cups to turn inside out and be certain the snap ring is firmly seated in the groove.

Install the boot.

Install the brake lever onto the master cylinder and tighten the pivot bolt and nut.

TORQUE: 8–12 N·m (0.8–1.2 kg·m, 6–9 ft·lb)

Install the rubber cover.

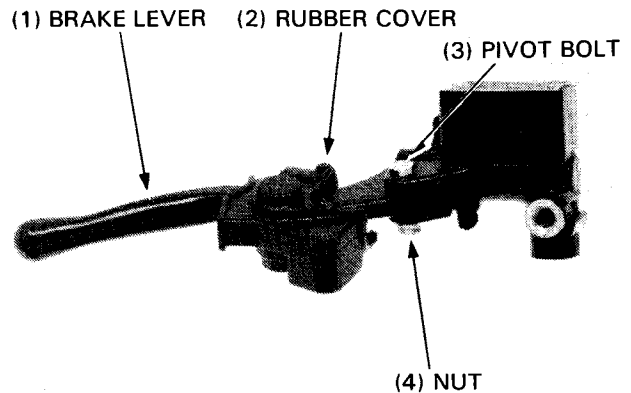
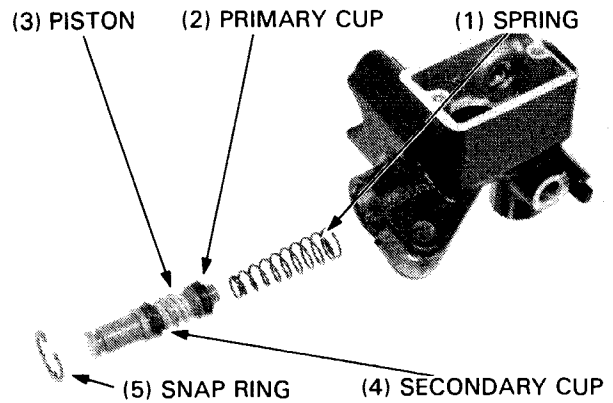

INSTALLATION

Place the front brake master cylinder on the handlebar and install its holder with the "UP" mark facing up.

Align the end of the holder with the punch mark on the handlebar and tighten the upper screw first, then tighten the lower screw.

Align the lower edge of the throttle housing with the punch mark on the handlebar and tighten the forward screw first, then tighten the rear screw.

Connect the brake hose to the master cylinder using the oil bolt and two sealing washers so the hose joint neck is positioned in the stoppers on the master cylinder body.

Make sure that the oil bolt sealing washers are in good condition.

Tighten the oil bolt.

TORQUE: 25–35 N·m (2.5–3.5 kg·m, 18–25 ft·lb)

Fill and bleed the front hydraulic system (page 14-4).

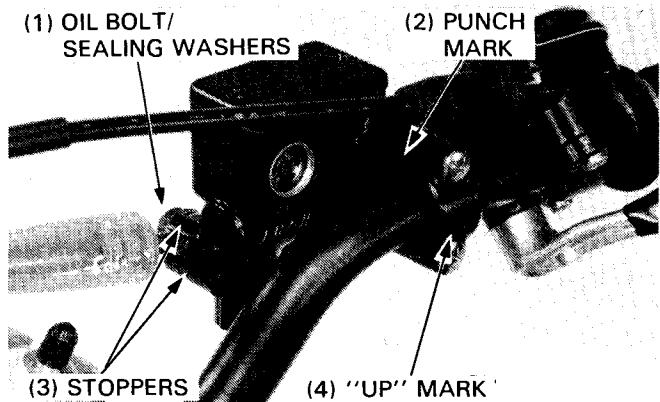

REAR MASTER CYLINDER

REMOVAL

Remove the rear master cylinder mounting bolts.

Disconnect the master cylinder push rod from the rear brake actuating arm by removing the cotter pin and joint pin.

Disconnect the brake hose from the master cylinder.

Remove the hose connector screws and disconnect the reservoir hose.

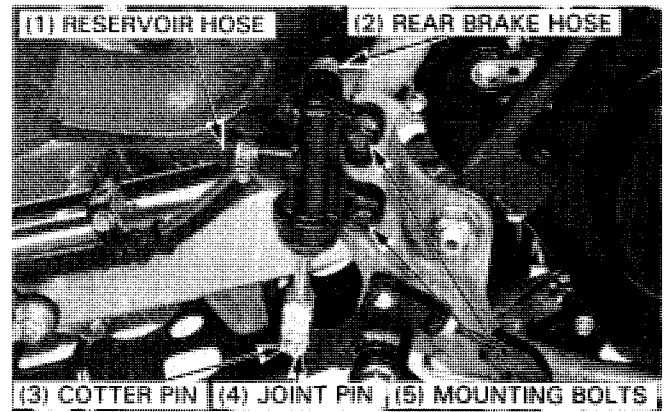

DISASSEMBLY

Remove the rubber boot.

Remove the snap ring and push rod.

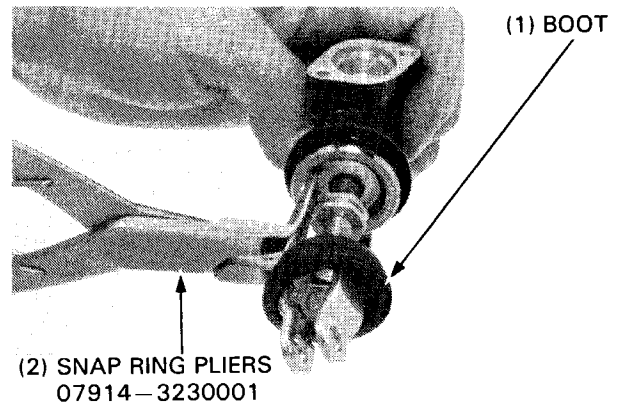

Remove the piston and spring.

Clean the piston and the inside of the master cylinder with brake fluid.

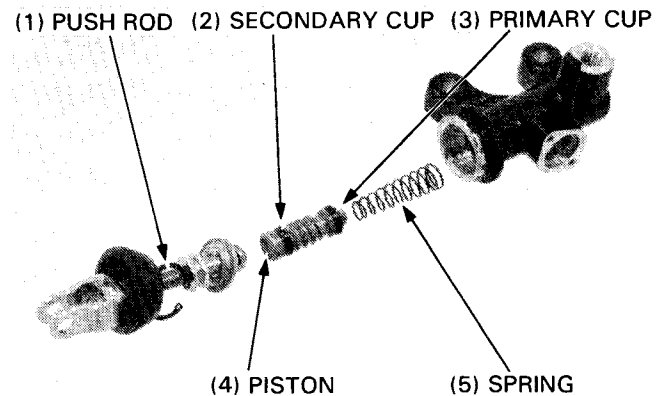

INSPECTION

Check the primary and secondary cups for wear, deterioration or damage.

Check the master cylinder and piston for scratches, scoring or damage.

Measure the master cylinder inside diameter and the piston outside diameter.

SERVICE LIMITS:

MASTER CYLINDER I.D.: 12.755 mm (0.5022 in)
PISTON O.D.: 12.645 mm (0.4978 in)

Replace the parts that are worn beyond the service limit.

NOTE

- The piston, piston cups and spring must be replaced as a set.

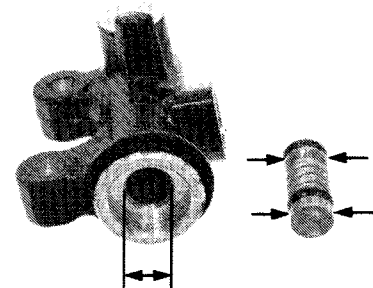

HYDRAULIC BRAKES

ASSEMBLY

Coat the piston, primary and secondary cups with clean brake fluid, install the spring and piston with cups.

Install the push rod and snap ring.

CAUTION

- *Do not allow the lips of the cups to turn inside out and be certain the snap ring is seated in the groove.*

Install the rubber boot.

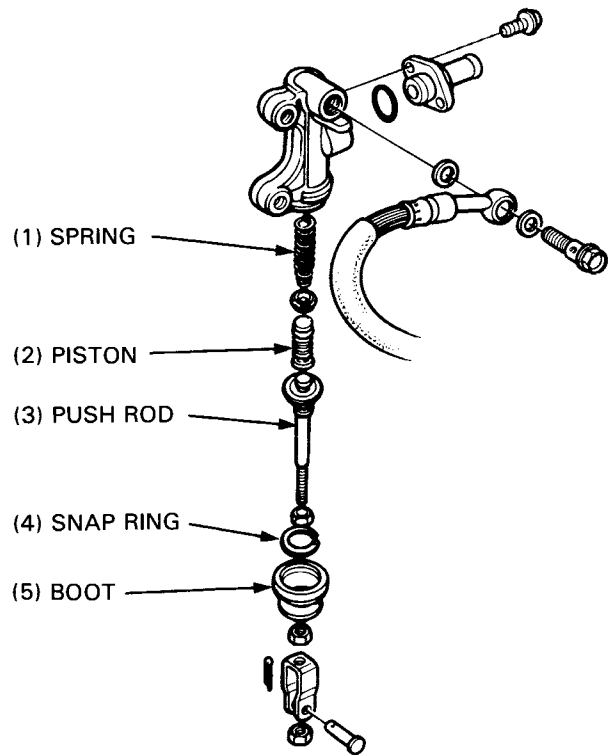

INSTALLATION

Install the master cylinder to the frame and tighten the mount bolts.

Connect the reservoir hose joint to the master cylinder with a new O-ring and the screws.

TORQUE: 1–2 N·m (0.1–0.2 kg·m, 0.7–1.5 ft·lb)

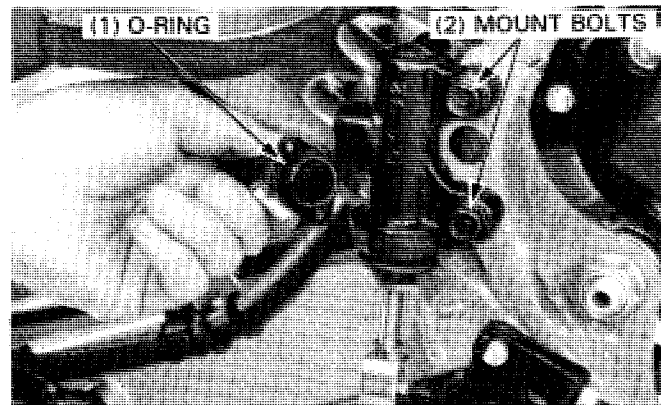

Connect the master cylinder push rod and actuating arm with the joint pin and secure it with a new cotter pin.

Make sure that the oil bolt sealing washers are in good condition.

Connect the rear brake hose with the oil bolt and two sealing washers, and tighten the oil bolt.

TORQUE: 25–35 N·m (2.5–3.5 kg·m, 18–25 ft·lb)

Fill and bleed the rear hydraulic system (page 14-4).

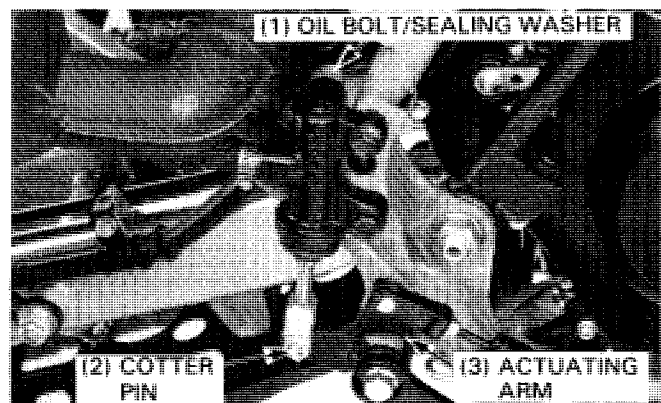

15. REAR FENDER/SEAT/EXHAUST SYSTEM

SERVICE INFORMATION

15-1

EXHAUST SYSTEM

15-2

REAR FENDER/SEAT

15-1

SERVICE INFORMATION

GENERAL

- Refer to section 3 for spark arrester cleaning.

WARNING

- *Do not service the exhaust system while it is hot.*

REAR FENDER/SEAT

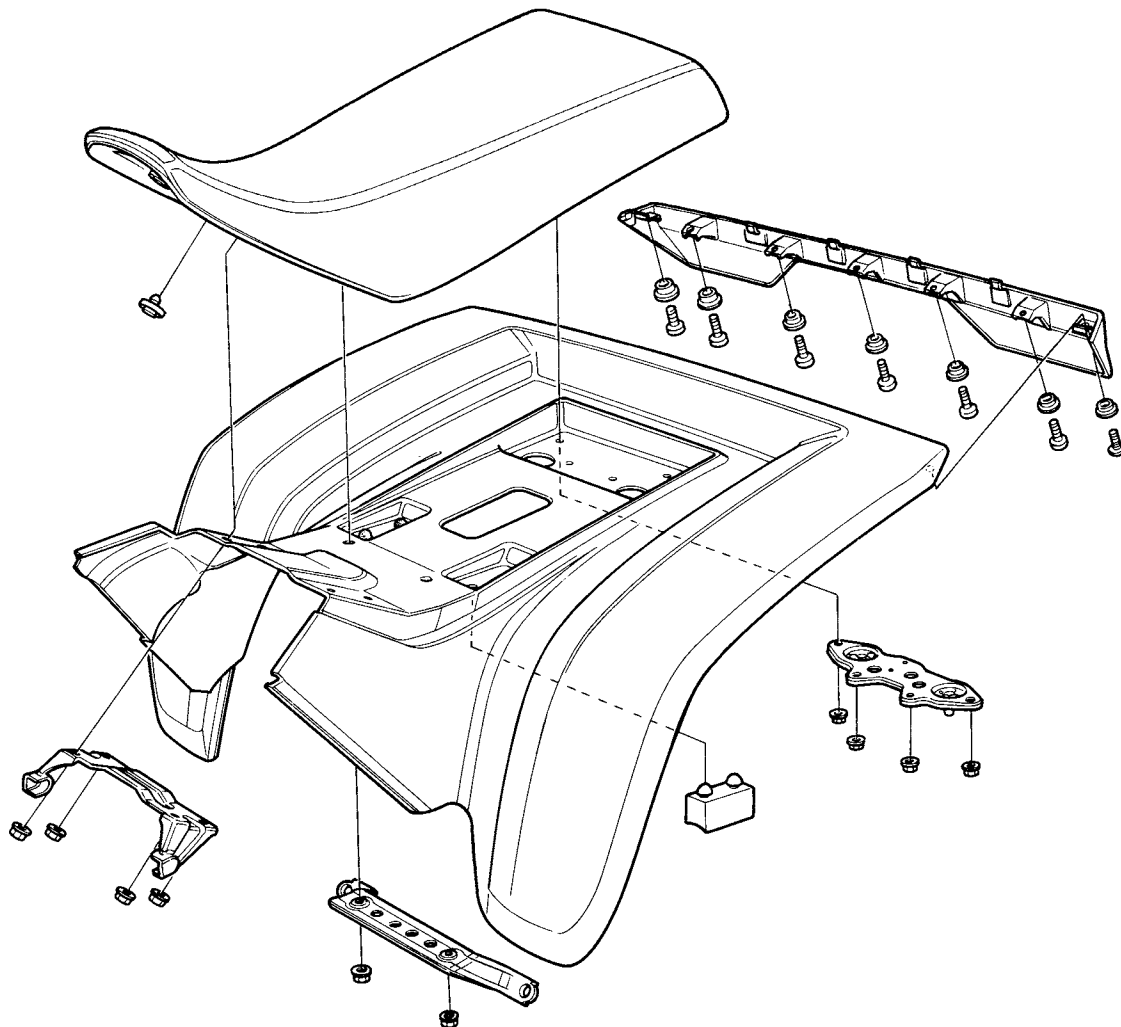

REAR FENDER/SEAT/EXHAUST SYSTEM

REMOVAL

Release the seat lock by moving the lever in the direction shown and remove the seat and rear fender.

INSTALLATION

Apply grease to the seat catch.

Install the seat and fender in the reverse order of removal.

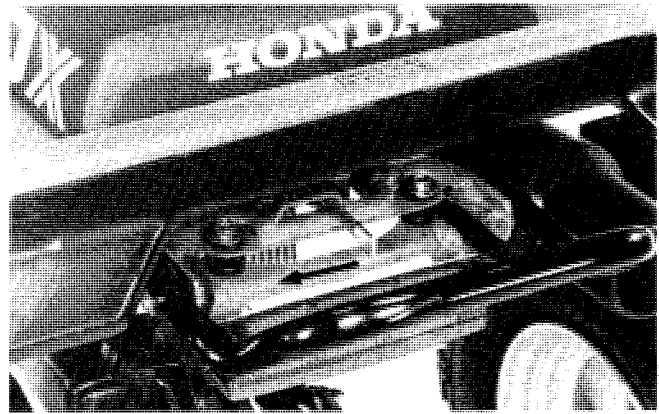

EXHAUST SYSTEM

WARNING

- *Do not service the exhaust pipe or muffler while they are hot.*

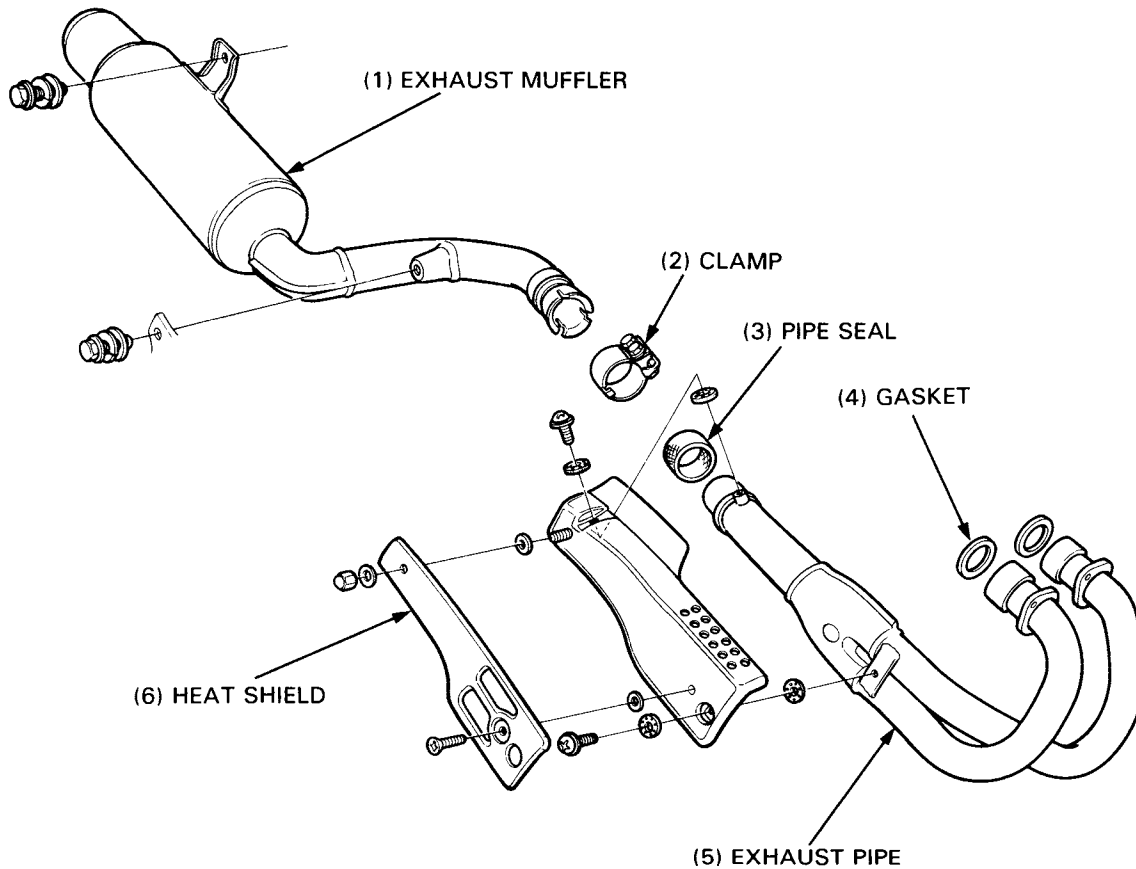

REMOVAL

Remove the seat/rear fender.

Remove the exhaust pipe joint nuts.

Loosen the exhaust pipe clamp bolts.

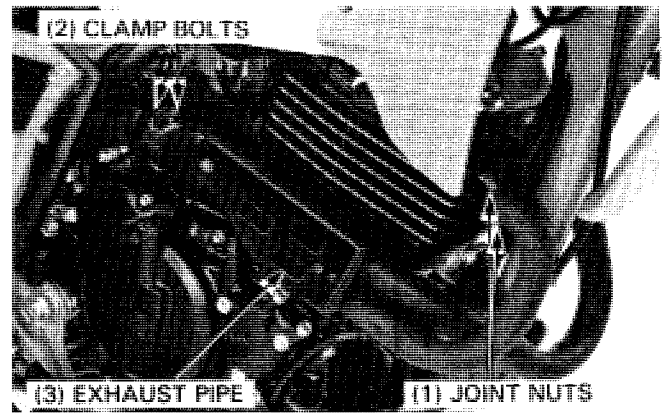

Remove the exhaust muffler mount bolts and remove the muffler and exhaust pipe.

Check the gasket and pipe seal for wear or damage and replace them if necessary.

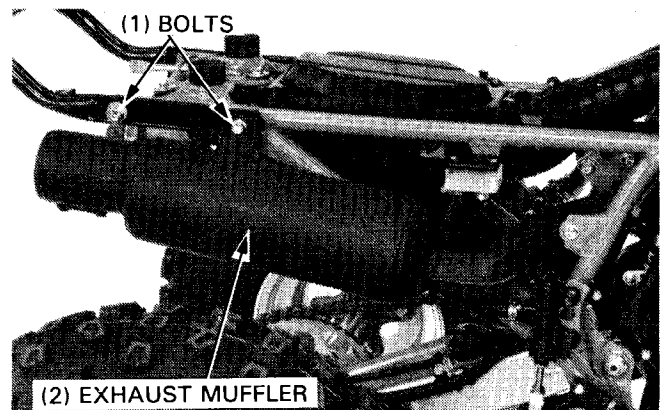

INSTALLATION

The installation sequence is essentially the reverse of removal.

NOTE

- Tighten the exhaust joint nuts first, then tighten the other bolts.
- Align the tab of the clamp with the groove of the muffler.
- After installing, make sure that there are no exhaust leaks.

ELECTRICAL SYSTEM

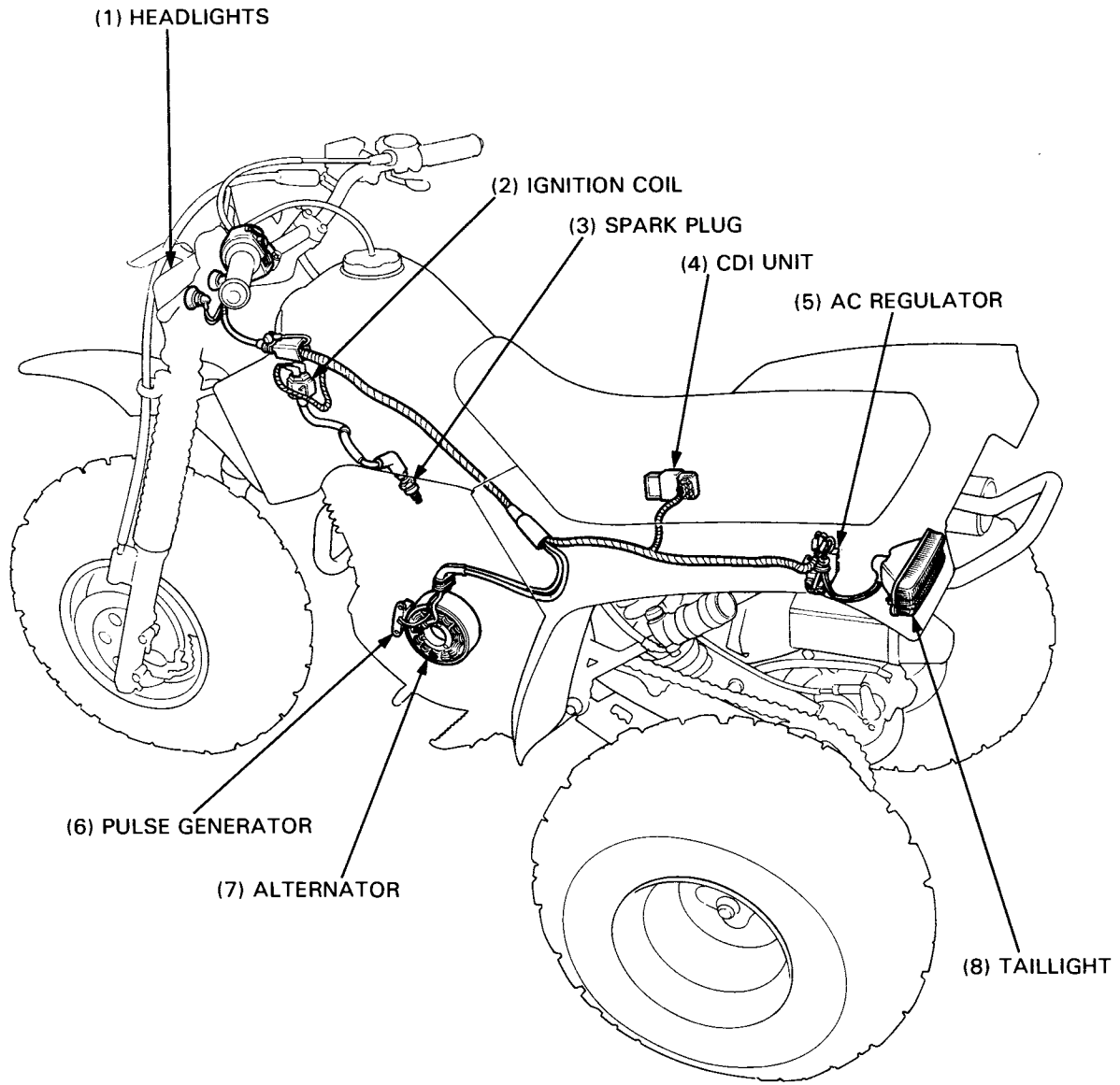

16. ELECTRICAL SYSTEM

SERVICE INFORMATION	16-1	AC REGULATOR	16-7
TROUBLESHOOTING	16-2	SWITCHES	16-8
IGNITION SYSTEM	16-3	WIRING DIAGRAM	16-9
LIGHTS	16-5		

SERVICE INFORMATION

GENERAL

- Ignition timing does not need to be adjusted since the CDI (Capacitive Discharge Ignition) unit is factory pre-set.
- For spark plug inspection and ignition timing check, refer to section 3.
- For pulse generator, exciter coil and lighting coil removal, refer to section 7.
- All plastic connectors have locking tabs that must be released before disconnecting, and must be align when reconnecting.
- A continuity check can usually be made without removing the part from the ATC by simply disconnecting the wires and connecting a continuity tester or voltmeter to the terminals or connections.

SPECIFICATIONS

ITEM		STANDARD
Spark plug	Gap	0.6–0.7 mm (0.024–0.028 in)
	Recommended plug	DR8ES-L (NGK), X24ESR-U (ND)
Ignition coil	Primary coil resistance	0.16–0.2 Ω
	Secondary coil resistance (Without spark plug cap)	3.69–4.51 k Ω
Exciter coil resistance		20–150 Ω (ND), 200–350 Ω (MITSUBA)
Pulse generator coil resistance		297–363 Ω
Ignition timing	Initial ("F" mark)	10° BTDC/1,400 \pm 100 rpm
	Full advance	30° BTDC/3,500 \pm 200 rpm
Lighting coil resistance		0.1–1.0 Ω (ND), 0.2–1.0 Ω (MITSUBA)
AC regulator	Regulating voltage	13.5–14.5 V
	Resistance	100 k Ω – ∞
Alternator		200W/5,000 rpm
Headlight		12V–36.5W/35W
Taillight		12V–5W

TROUBLESHOOTING

No spark at plug

- Faulty spark plug.
- Poorly connected, broken or shorted wires.
 - Between alternator and CDI unit.
 - Between CDI unit and engine stop switch.
 - Between CDI unit and ignition coil.
 - Between ignition coil and spark plug.
 - Between pulse generator and CDI unit.
- Faulty ignition coil.
- Faulty CDI unit.
- Faulty pulse generator.
- Faulty alternator.

Engine starts but runs poorly

- Ignition primary circuit.
 - Faulty ignition coil.
 - Loose or bare wire.
 - Faulty alternator.
 - Faulty CDI unit.
 - Faulty pulse generator.
- Ignition secondary circuit.
 - Faulty plug.
 - Faulty spark plug wire.
 - Faulty ignition coil.
- Improper ignition timing.
 - Faulty pulse generator.
 - Faulty CDI unit.

No lights when engine is running

- Faulty bulb.
- Poorly connected or loose connectors.
- Faulty alternator.

IGNITION SYSTEM

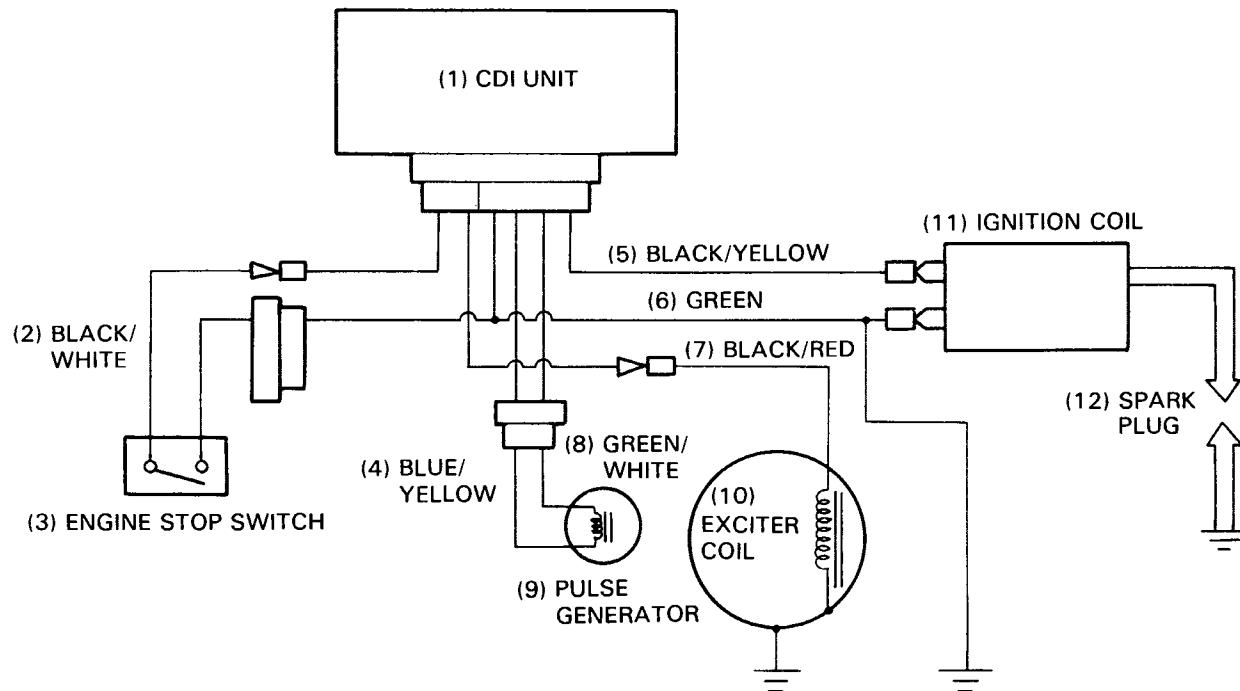

IGNITION COIL

Remove the spark plug cap.

Disconnect the primary and ground wires from the ignition coil. Remove the ignition coil.

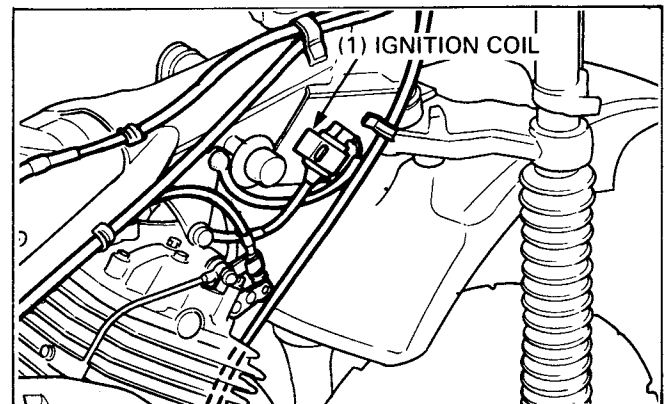

Measure the primary coil resistance between the primary and ground terminals.

PRIMARY COIL RESISTANCE: 0.16—0.2 Ω

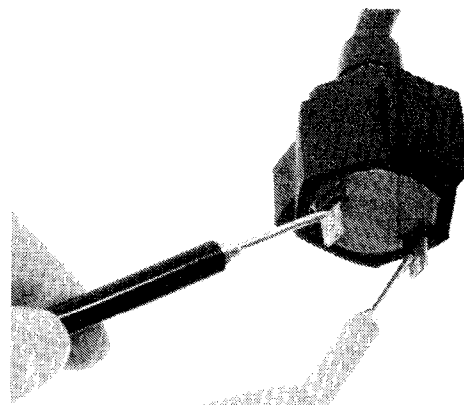

ELECTRICAL SYSTEM

Remove the spark plug cap from the spark plug wire.

Measure the secondary coil resistance without the spark plug cap.

SECONDARY COIL RESISTANCE: 3.69–4.51 k Ω

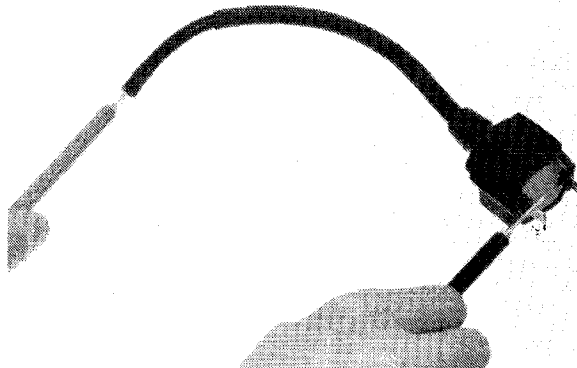

EXCITER COIL

Remove the seat/rear fender.

Disconnect the exciter coil wire connector.

Measure the exciter coil resistance between the wire terminal and ground.

**EXCITER COIL RESISTANCE: 20–150 Ω (ND),
200–350 Ω (MITSUBA)**

For exciter coil replacement, refer to section 9.

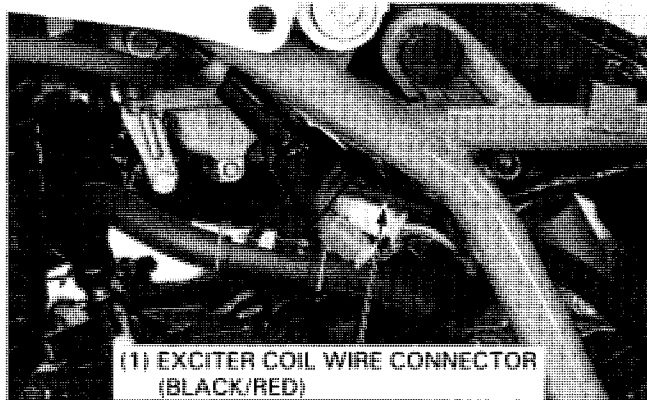

CDI UNIT

Remove the seat/rear fender.

Disconnect the CDI unit wire coupler and remove the CDI unit.



Measure the resistance between the terminals. Replace the CDI unit if the readings are not within the specifications in the table on the following page.

NOTE

- The CDI unit is fully transistorized.
- For accurate testing, it is necessary to use a specified electric tester. Use of an improper tester may give a false reading.
- Use Sanwa Electric Tester (07308–0020000) or Kowa Tester (TH-5H-1) or Kowa Digital Multi-Tester (07411–0020000 or KS-AHM-32-003: U.S.A. only).

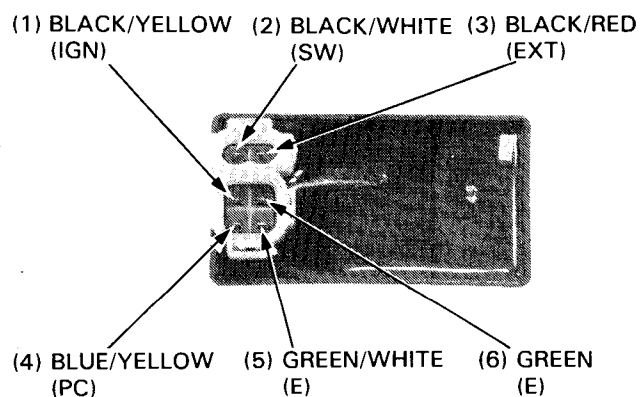

Unit: k Ω

\ominus \ \oplus	BLACK/ WHITE (SW)	GREEN (E)	BLACK/RED (EXT)	GREEN/ WHITE (E)	BLUE/ YELLOW (PC)	BLACK/ YELLOW (IGN)
BLACK/WHITE (SW)		∞	∞	∞	∞	∞
GREEN (E)	1–100		∞	0	1–100	500–5,000
BLACK/RED (EXT)	1–100	50–500		50–500	50–1,000	500–5,000
GREEN/WHITE (E)	1–100	0	∞		1–100	500–5,000
BLUE/YELLOW (PC)	5–500	5–500	∞	5–500		800– ∞
BLACK/YELLOW (IGN)	∞	∞	∞	∞	∞	

PULSE GENERATOR

Remove the seat/rear fender.

Disconnect the pulse generator wire coupler.
Measure the pulse generator coil resistance between the coupler terminals.

PULSE GENERATOR COIL RESISTANCE: 297–363 Ω

For pulse generator coil replacement, refer to section 7.

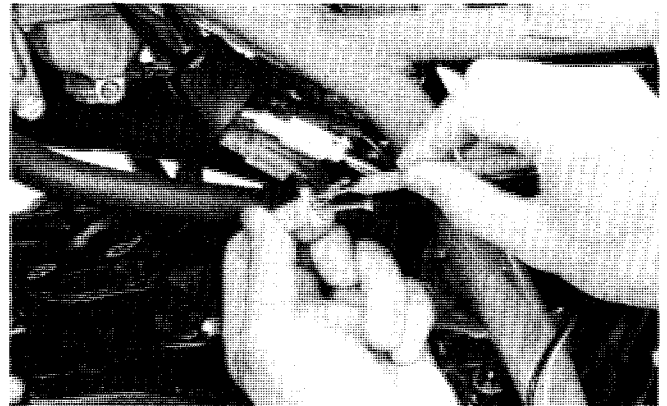

LIGHTS

Apply the parking brake and start the engine.

Check the headlight and taillight by operating the headlight ON-OFF switch.

Operate the dimmer switch and check the headlight vertical beam.

Adjust the vertical beam by turning the adjusting screws.

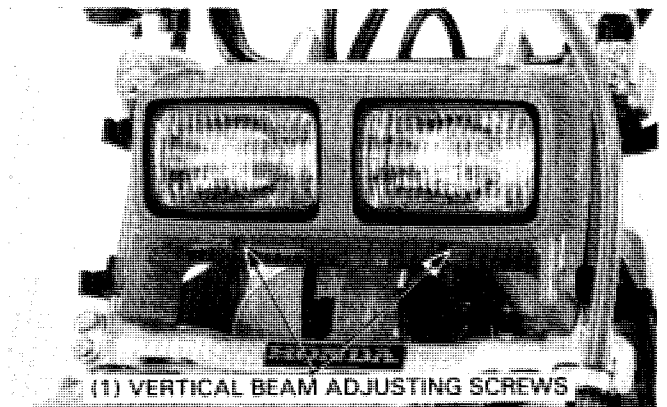

HEADLIGHT BULB REPLACEMENT

Remove the headlight case from the front fork tubes by releasing the four retaining bands.

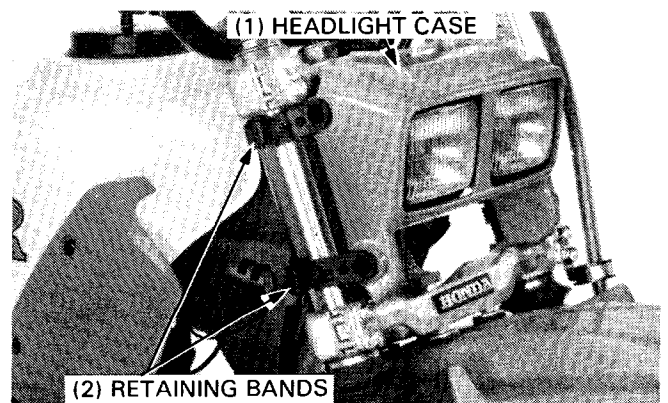

ELECTRICAL SYSTEM

Remove the dust cover.

Remove the bulb retainer by turning it counterclockwise while pushing it in.

Replace the bulb with a new one. Align the tab on the bulb flange with the groove in the headlight.

Install the removed parts in the reverse order of removal.

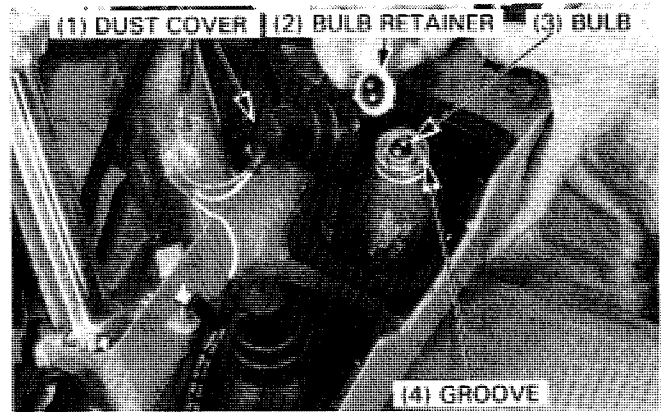

HEADLIGHT DISASSEMBLY/ASSEMBLY

Remove the headlight.

Remove the adjusting screws and headlight mount screw and remove the headlights from the cover.

Assemble the headlights in the reverse order of disassembly.

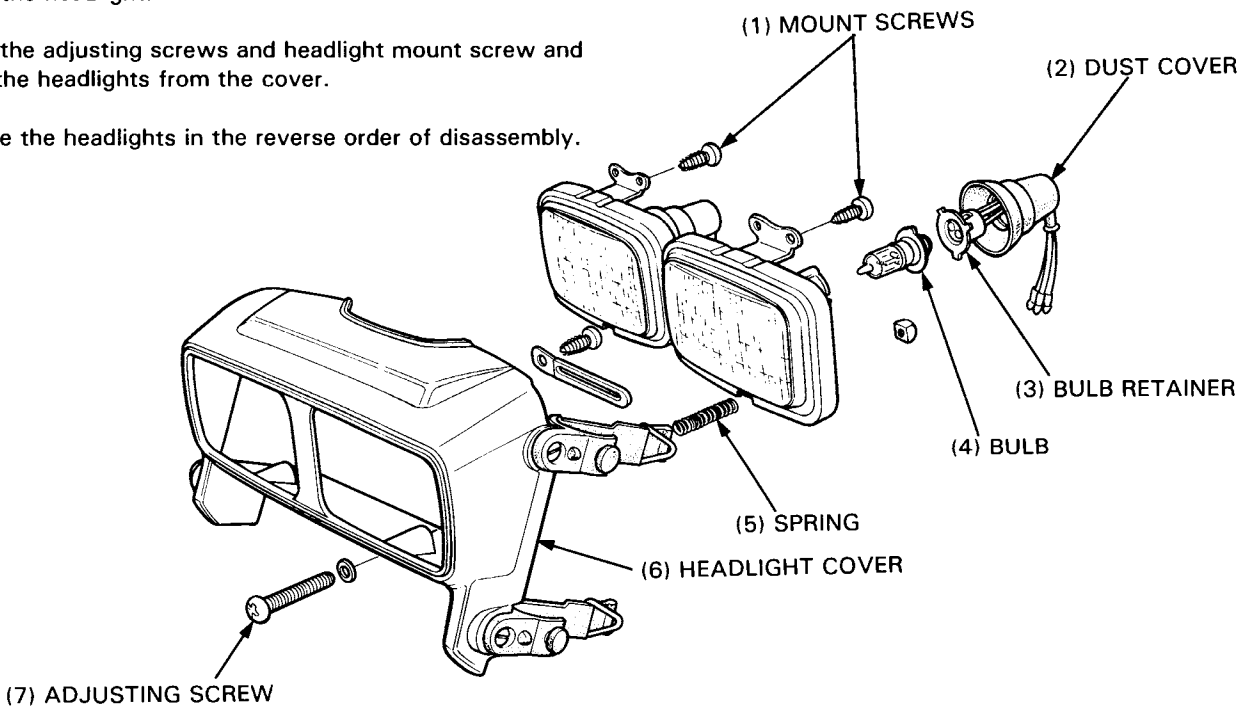

TAILLIGHT BULB REPLACEMENT

Remove the taillight lens by removing the two screws and nuts.

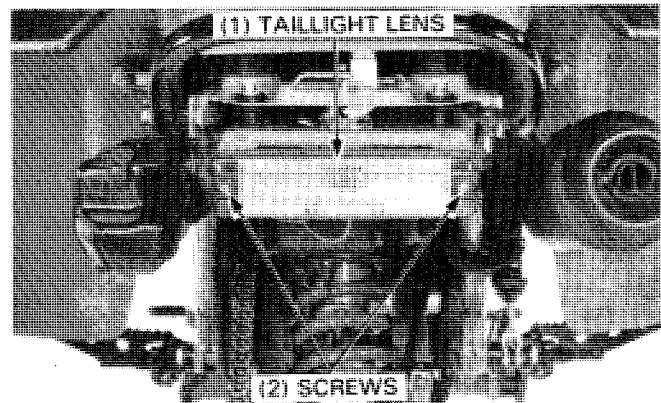

Remove the taillight bulb by pushing it in and turning it counterclockwise. Replace the faulty bulb with a new one.

Install the removed parts in the reverse order of removal.

NOTE

- Make sure that the taillight lens rubber seal is in good condition.
- Be sure to install the washers on both side of the rubber mount.

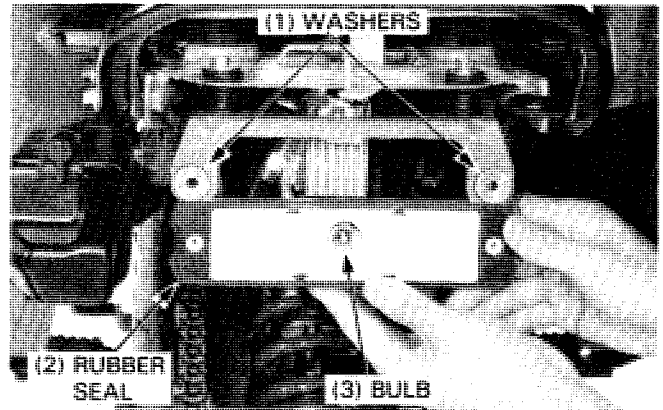

ALTERNATOR LIGHTING COIL

Remove the seat/rear fender.

Disconnect the alternator lighting coil coupler. Measure the lighting coil resistance between the coupler terminals.

RESISTANCE: 0.1–1.0 Ω (ND), 0.2–1.0 Ω (MITSUBA)

For alternator replacement, refer to section 7.

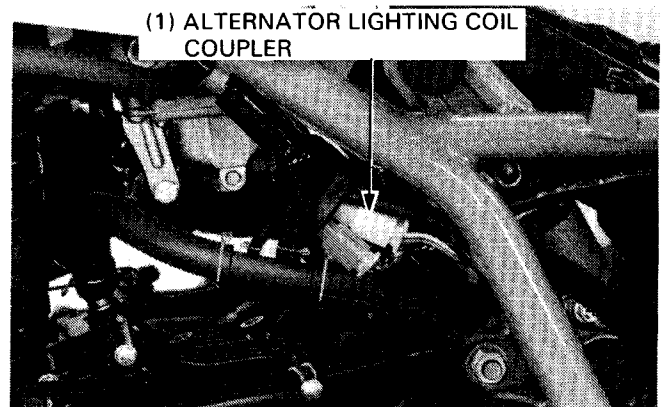

AC REGULATOR

Disconnect the lighting switch coupler:

Start the engine and measure the voltage between the white/yellow and green wire terminals at the main harness side of the coupler.

VOLTAGE: 13.5–14.5 V

If the voltage is not within specifications, check the AC regulator.

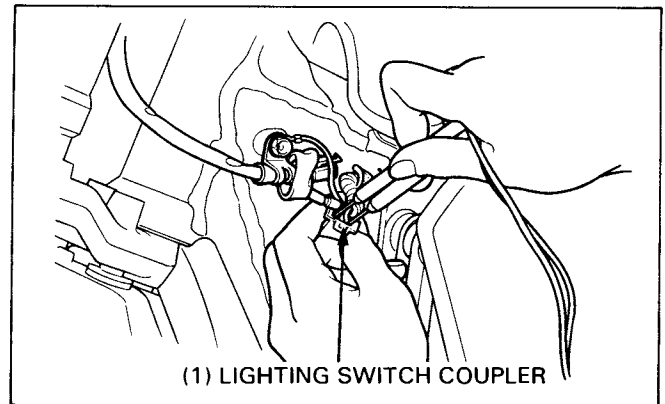

Remove the seat/rear fender.

Disconnect the AC regulator wire connectors, and remove the regulator attaching bolt and the regulator.

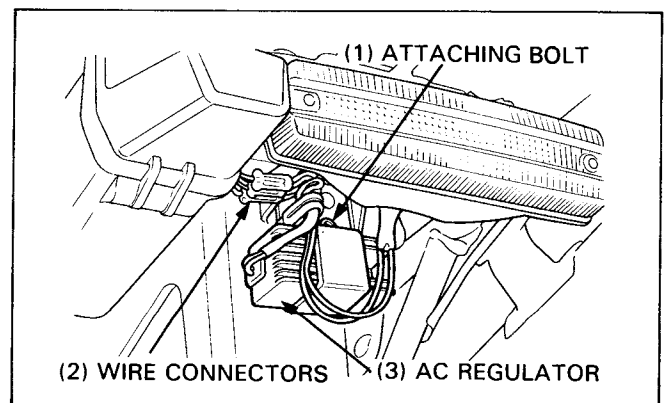

ELECTRICAL SYSTEM

Measure the resistance between the wire terminals.

RESISTANCE: 100 k Ω — ∞

Replace the AC regulator with a new one if the resistance is not within the specifications.

Install the regulator in the reverse order of removal.

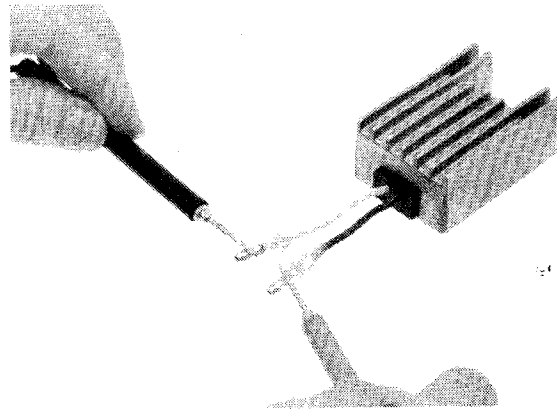

SWITCHES

NOTE

- The engine stop switch, lighting switch and dimmer switch must be replaced as an assembly.

Remove the headlight case and disconnect the engine stop switch/lighting switch wire coupler and connector.

Continuity should exist between the color coded wires in each chart.

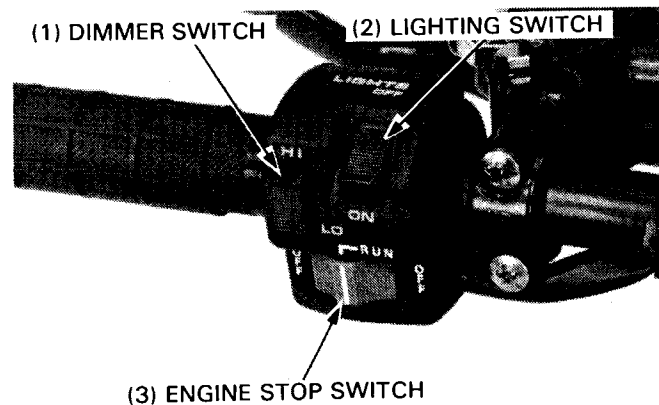

ENGINE STOP SWITCH

COLOR CODE	BLACK/ WHITE	GREEN
SWITCH POSITION		
OFF	○	○
RUN		

LIGHTING STOP SWITCH

COLOR CODE	WHITE/ YELLOW	BROWN
SWITCH POSITION		
OFF		
ON	○	○

DIMMER SWITCH

COLOR CODE	BROWN	BLUE	WHITE
SWITCH POSITION			
HI	○	○	
(N)	○	○	○
Lo	○		○

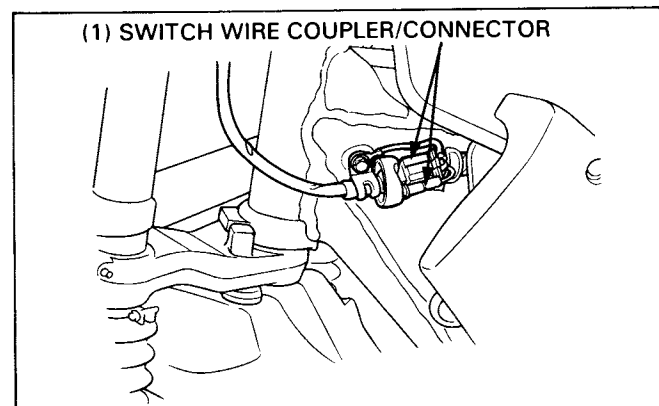

WIRING DIAGRAM

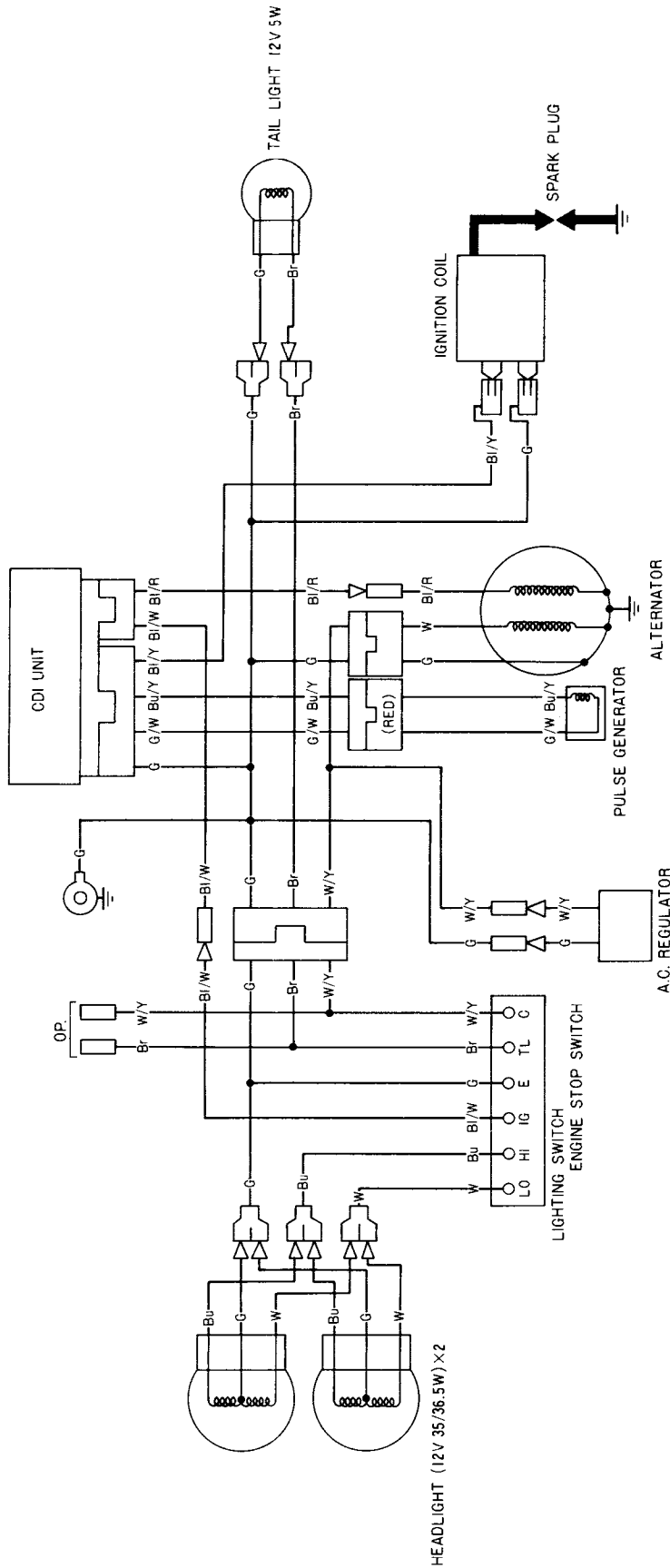

- Br Brown
- O Orange
- Lb Light Blue
- Lg Light Green
- P Pink
- Gr Grey
- Bl Black
- Y Yellow
- Bu Blue
- G Green
- R Red
- W White

ENGINE STOP SWITCH

IG	E
OFF	ON
COLOR	Bl/W G

DIMMER SWITCH

TL	Hi	Lo
Hi	(N)	Lo
COLOR	Br	Bu W

SWITCH CONTINUITY

LIGHTING SWITCH

C	TL
OFF	ON
COLOR	W/Y Br

0030 Z - HA 5^A - 0100

MEMO

17. TROUBLESHOOTING

ENGINE DOES NOT START OR IS HARD TO START	17-1	POOR PERFORMANCE AT HIGH SPEEDS	17-4
ENGINE LACKS POWER	17-2	POOR HANDLING	17-4
POOR PERFORMANCE AT LOW AND IDLE SPEEDS	17-3		

ENGINE DOES NOT START OR IS HARD TO START

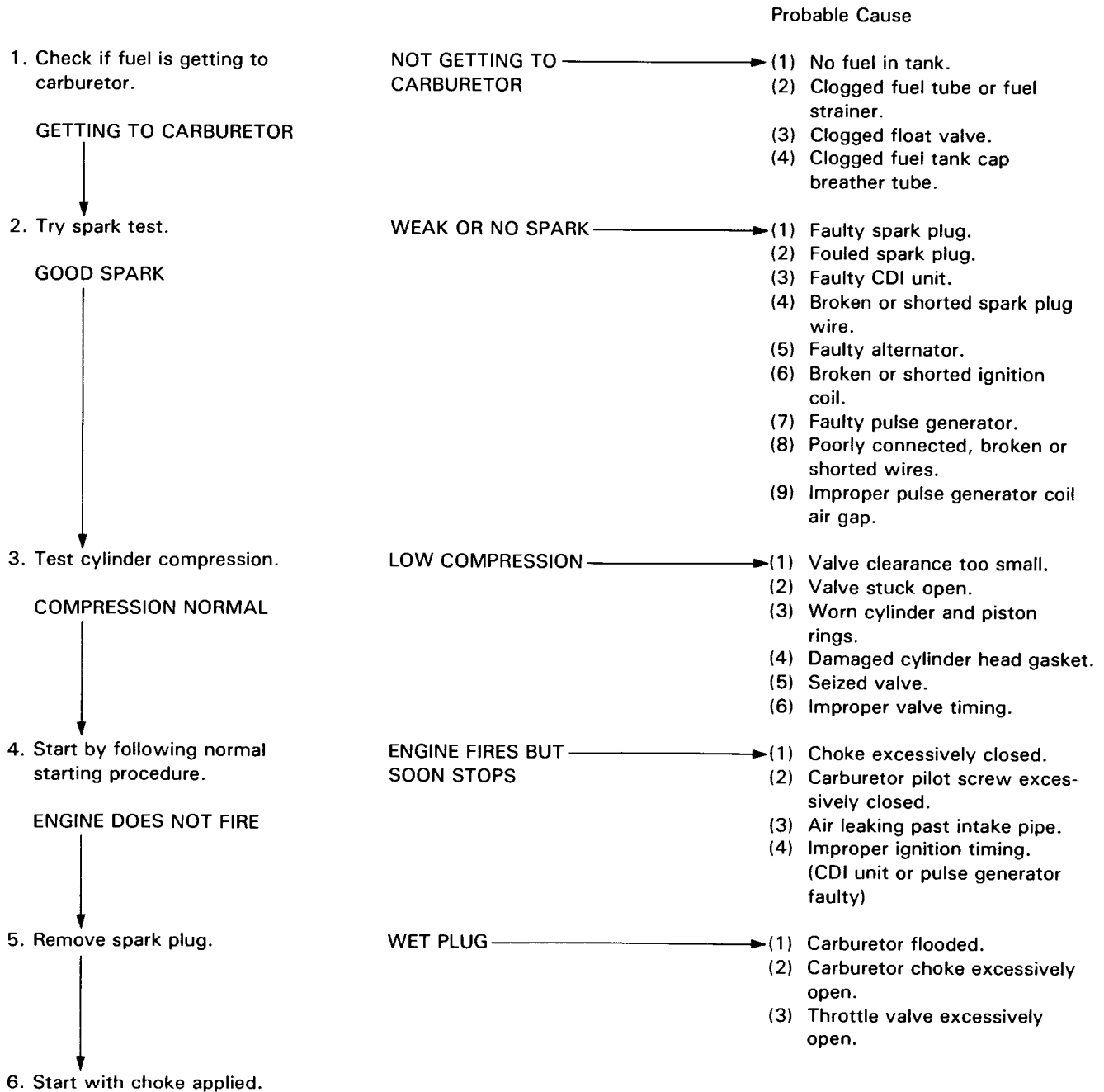

ENGINE LACKS POWER

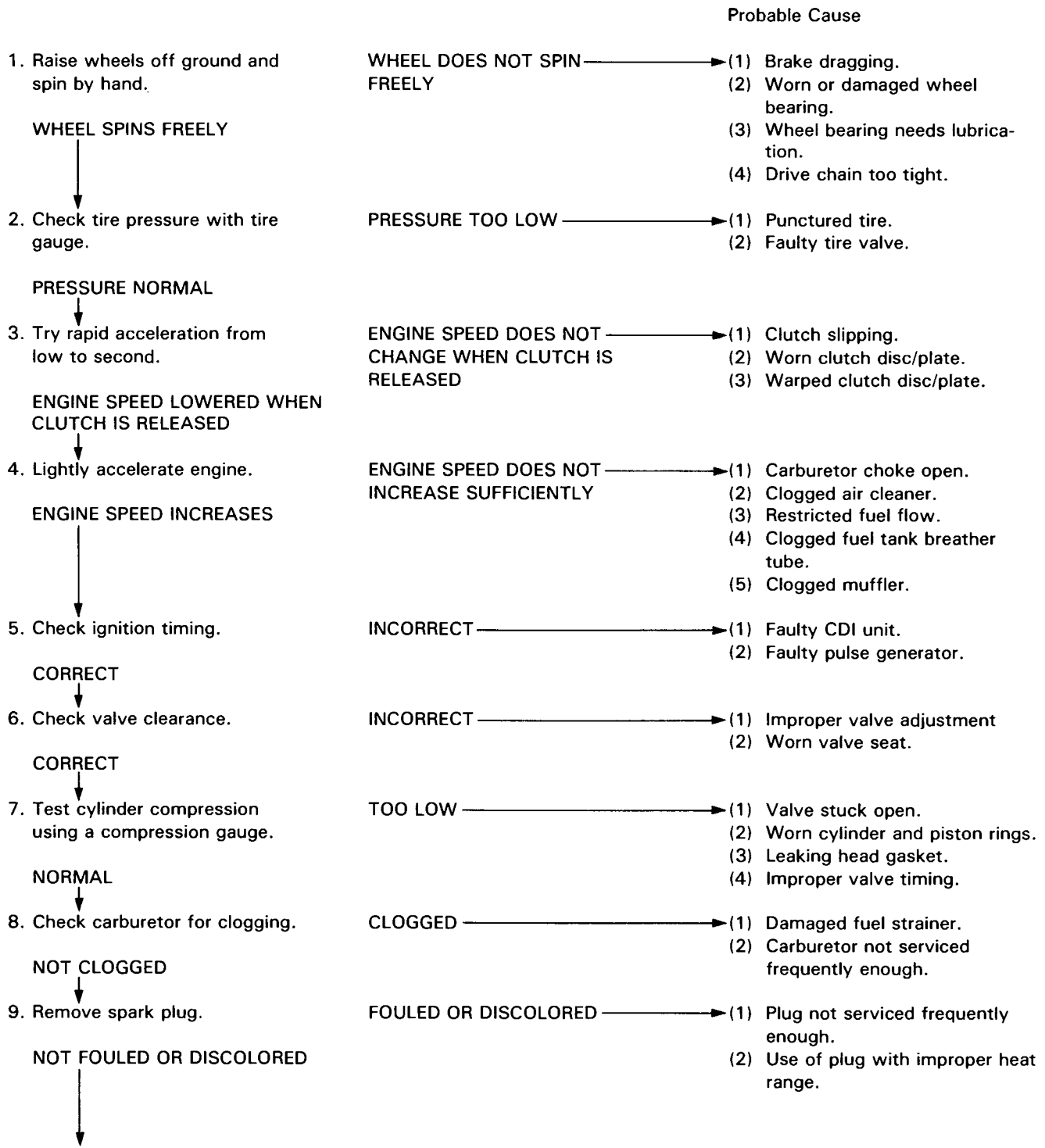

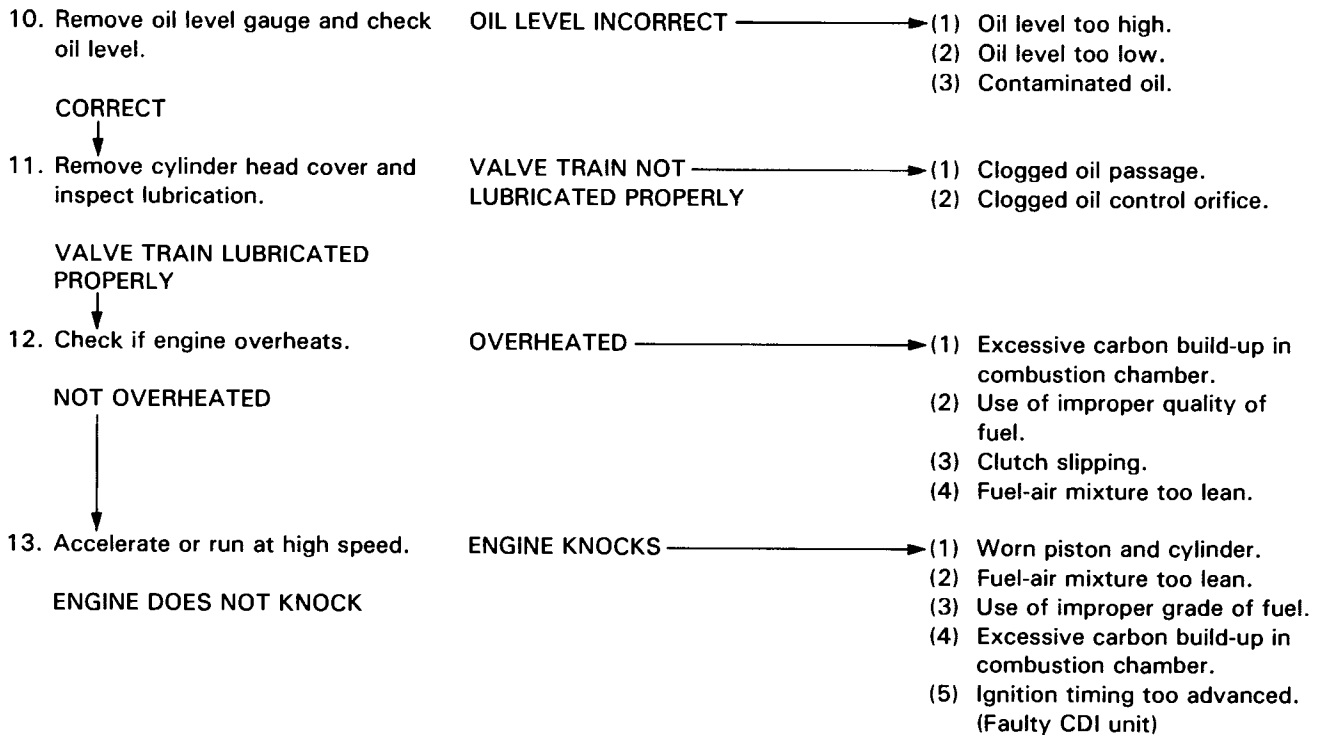

POOR PERFORMANCE AT LOW AND IDLE SPEEDS

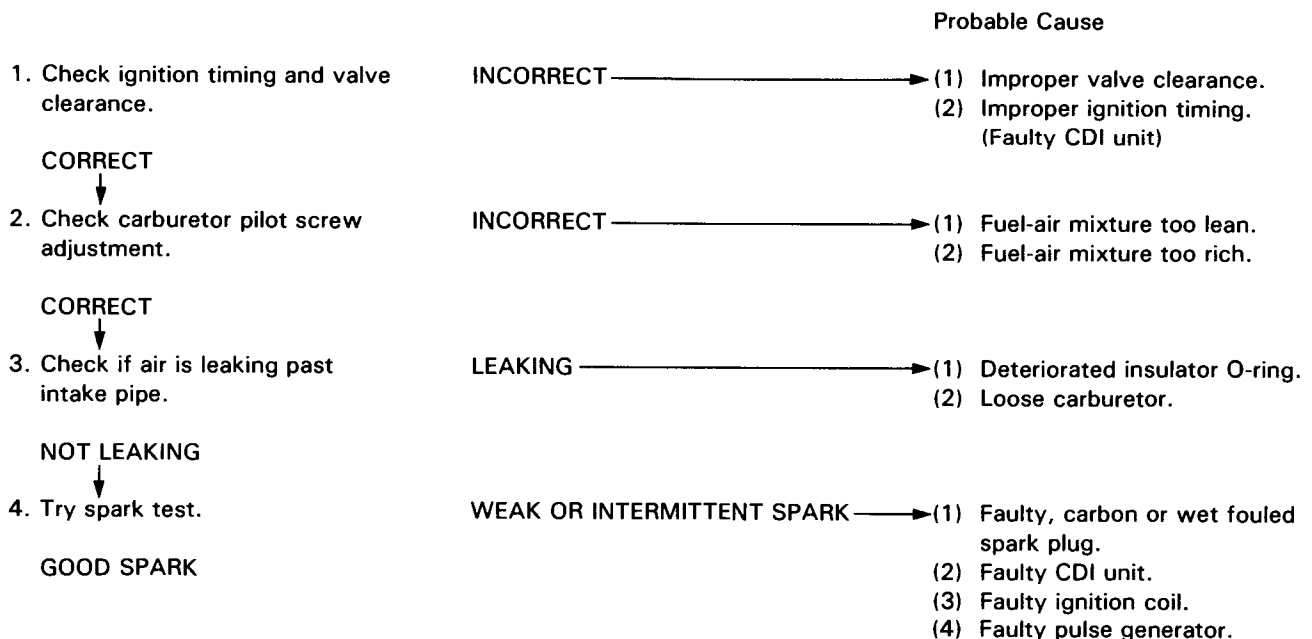

TROUBLESHOOTING

POOR PERFORMANCE AT HIGH SPEEDS

		Probable Cause
1. Check ignition timing and valve clearance.	INCORRECT	(1) Improper valve clearance. (2) Faulty CDI unit. (3) Faulty pulse generator.
CORRECT		
2. Disconnect fuel tube at carburetor.	FUEL FLOW RESTRICTED	(1) Lack of fuel in tank. (2) Clogged fuel line. (3) Clogged fuel tank breather tube. (4) Clogged fuel valve. (5) Clogged fuel strainer.
FUEL FLOWS FREELY		
3. Remove carburetor and check for clogged jet.	CLOGGED	Clean.
NOT CLOGGED		
4. Check valve timing.	INCORRECT	Cam sprocket not installed properly.
CORRECT		
5. Check valve spring tension.	WEAK	Faulty spring.
NOT WEAKENED		

POOR HANDLING

Check tire pressure

	Probable Cause
1. If steering is heavy	(1) Steering head adjuster too tight. (2) Damaged steering stem bearing. (3) Bent steering stem.
2. If either wheel is wobbling	(1) Excessive wheel bearing play. (2) Bent rim. (3) Improperly installed wheel hub. (4) Swing arm pivot bearing and bushing excessively worn. (5) Distorted frame. (6) Improper drive chain adjustment. (7) Bent axle.
3. If the vehicle pulls to one side	(1) Rear tire pressure not equal. (2) Bent front fork. (3) Bent swing arm.
4. If the front suspension is too soft	(1) Weak springs. (2) Insufficient front fork oil.

5. If the front suspension is hard → (1) Incorrect front fork oil (viscosity too high).
(2) Excessive front fork oil.
(3) Excessive fork air pressure.
6. If the rear suspension is too soft → (1) Weak spring.
(2) Improper rear suspension adjustment.
(3) Insufficient nitrogen gas pressure.
7. If the rear suspension is hard → (1) Improper rear suspension adjustment.
(2) Bent shock absorber rod.

MEMO

18. INDEX

Ac Regulator	16-7	General Information	1-1
Air Cleaner	3-4	Handlebar	11-3
Case	4-4	High Altitude Adjustment	4-12
Case Breather	3-4	Hydraulic Brakes	14-1
Alternator/Gearshift Linkage	9-1	Ignition System	16-3
Alternator	9-3	Timing	3-8
Brake Disc	14-10	Kick Starter	8-14
Fluid	3-13	Left Crankcase Cover Installation	9-8
Fluid Replacement/Bleeding	14-3	Removal	9-2
Pad Replacement	14-6	Lights	16-5
Pads	3-12	Lubrication	2-1
System	3-13	Points	2-4
Cable & Harness Routing	1-9	Maintenance	3-1
Cam Chain Tensioner	6-11	Schedules	3-2
Lifter Assembly	6-15	Model Identification	1-2
Lifter Disassembly	6-4	Noise Emission Control System (U.S.A. Only)	1-13
Camshaft Installation	6-14	Nuts, Bolts, Fasteners	3-17
Removal	6-5	Oil Cooler	2-3
Carburetor Choke	4-6	Filter Screen Cleaning	8-6
Installation	4-11	Pump	8-10
Removal	4-5	Pilot Screw Adjustment	4-11
Carburetor-Idle Speed	3-6	Piston Installation	7-5
Clutch/Oil Pump/Kick Starter	8-1	Removal	7-3
Clutch	3-16, 8-6	Primary Drive Gear	8-13
Crankcase/Transmission/Crankshaft	10-1	Rear Fender/Seat	15-1
Crankcase Assembly	10-14	Rear Suspension	13-1
Breather	3-5	Wheels	12-1
Separation	10-4	Axle	12-3
Crankshaft	10-11	Brake Pedal	14-23
Cylinder Head/Valves	6-1	Brake Pivots	3-15
Cylinder/Piston	7-1	Caliper	14-14
Cylinder Compression	3-9	Fender/Seat/Exhaust System	15-1
Head Assembly	6-12	Master Cylinder	14-21
Cylinder Head Cover Assembly/Installation	6-17	Wheel	12-3
Removal Disassembly	6-3	Wheel Bearings	12-9
Cylinder Head Disassembly	6-7	Right Crankcase Cover Installation	8-19
Installation	6-13	Removal	8-3
Removal	6-6	Service Information	
Cylinder Installation	7-6	Alternator/Gearshift Linkage	9-1
Removal	7-2	Clutch/Oil Pump/Kick Starter	8-1
Drive Chain	3-10	Crankcase/Transmission/Crankshaft	10-1
Slider	3-11	Cylinder Head/Valves	6-1
Electrical System	16-1	Cylinder/Piston	7-1
General Safety	1-1	Electrical System	16-1
Engine Removal/Installation	5-1	Engine Removal/Installation	5-1
Installation	5-3	Front Wheel/Suspension/Steering	11-1
Oil & Filter Change	2-2	Fuel System	4-1
Oil Level	2-2	Hydraulic Brakes	14-1
Removal	5-2	Lubrication	2-1
Exhaust System	15-2	Maintenance	3-1
Float Chamber	4-7	Rear Fender/Seat/Exhaust System	15-1
Front Wheel/Suspension/Steering	11-1	Rear Suspension	13-1
Front Caliper	14-11	Rear Wheels	12-1
Fork	11-14	Service Rules	1-1
Master Cylinder	14-19	Shock Absorber	13-3
Wheel	11-6	Spark Arrester	3-16
Fuel System	4-1	Plug	3-5
Line	3-7	Specifications	1-3
Strainer Cleaning	4-3	Steering Head Bearings	3-18
Strainer Screen	3-7	Stem	11-21
Tank	4-3	Suspension	3-11
Gearshift Linkage	9-4	Swing Arm	13-10

INDEX

Switches	16-8
Throttle Operation	3-7
Valve	4-9
Tools	1-7
Torque Values	1-5
Transmission	10-5
Troubleshooting	
Alternator/Gearshift Linkage	9-1
Clutch/Oil Pump/Kick Starter	8-2
Crankcase/Transmission/Crankshaft	10-3
Cylinder Head/Valves	6-2
Cylinder/Piston	7-1
Electrical System	16-2
Front Wheel/Suspension/Steering	11-2
Fuel System	4-2
Hydraulic Brakes	14-2
Lubrication	2-1
Rear Suspension	13-2
Rear Wheels	12-2
Valve Clearance	3-5
Seat Inspection/Refacing	6-9
Wheels/Tires	3-17
Wiring Diagram	16-9