



SERVICE BULLETIN

AMERICAN HONDA MOTOR CO., INC. MOTORCYCLE SERVICE DEPARTMENT

1982-83 ATC200E SEAT COVER REPLACEMENT

Replacement seat covers for the ATC200E are now available from American Honda. It is no longer necessary to replace the entire seat assembly when only the seat cover is damaged. The following procedure makes it quick and easy to install a replacement cover.

1. Remove the damaged seat.
2. Use a small slot-headed screwdriver to pry up the metal tangs that hold the cover to the underside of the seat.

CAUTION: The tangs are very sharp. Wear gloves for hand protection.

3. Remove the old seat cover and discard it. Save the clear plastic inner liner.
4. Inspect the condition of the seat foam. Also, check to see how firmly the foam and the edge protector are secured to the seat base. If they are loose, reglue them with a flexible adhesive.
5. Use a pair of pliers to straighten all the tangs so that they stand straight out (90°) from the seat base.
6. Put the inner liner back over the foam with its pleat toward the rear of the seat.
7. Slip the new seat cover over the seat foam, beginning at the front. Pull it on until all the corners are aligned and there are no lumps under the cover.

8. Working from the underside of the seat, adjust the cover so that the tangs are aligned with the area between the stitch lines at the cover's edge. When the alignment is correct, push the center tang on each of the seat's four sides through the cover and bend them over as shown.

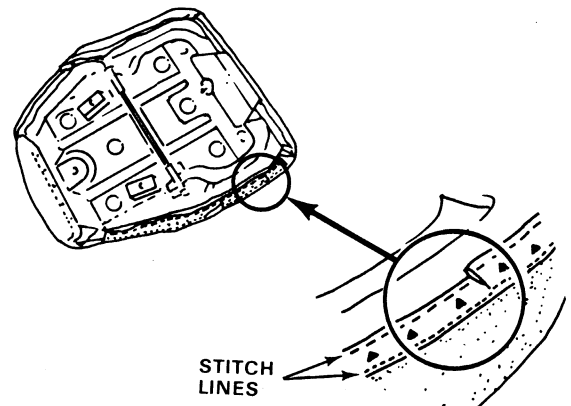

9. Turn the seat over and check to be sure that the cover is still properly aligned. When the alignment is correct, push the remaining tangs through the area between the stitch lines and bend them over.

NOTE: Use a blunt tool to bend the tangs.

PARTS INFORMATION

Replacement Seat Cover
H/C 1445402, P/N 77101-958-000

ROUTING:

COPY 1

COPY 2

GENERAL MANAGER

SERVICE MANAGER

SALES DEPT.

MECHANICS

OFFICE FILE

SHOP MANUAL

ATC200E #1
 FEBRUARY 1982

WARRANTY INFORMATION

Whenever a crate-damaged seat is being repaired under warranty, a replacement seat cover must be used. Submit warranty claim form W.O.2 with a total labor time of 0.2 hours (see example below.)

Retain all parts for D.S.M. inspection.

ALL PARTS ARE NEW UNLESS OTHERWISE NOTED

REPAIR PARTS AND LABOR					
A) ATC 200E SEAT COVER					
HONDA CODE	DEF. CODE	T	CODE (LABOR)	TIME	TOT. PTS.
1445402	021	1	8	0.2	
FOLLOWING PARTS REPLACED DUE TO ABOVE CAUSE					
QTY	HONDA CODE	DESCRIPTION OF PARTS		DEALER NET	
1	1445402	SEAT COVER			
DESCRIPTION OF DEFECTS					
Replace Seat Cover in accordance with Service Bulletin ATC200E #1.					
Special Labor or Sublet Repairs					

W.O.2 REV. 5-80

On your claim form, be sure to fill in the following items:

- 5-digit claim number
- Dealer number
- 17-digit frame number
- 7-digit engine number

AMERICAN HONDA MOTOR CO., INC.
 SERVICE DEPARTMENT

HONDA

ATC200E #2
REV. NOVEMBER 1983

SERVICE BULLETIN

AMERICAN HONDA MOTOR CO., INC. MOTORCYCLE SERVICE DEPARTMENT

ANNA
DO WE
HAVE PARTS?
2ND Bulletin?



1984 ATC200ES ADJUSTABLE FENDER BRACKET

(Supersedes Service Bulletin ATC200E #2, dated October 1983)

The frame dimensions for this ATC were changed slightly during production. Because of this, the fender mounting tabs on the frame (either left or right side) may not align properly with the mounting holes in the fenders.

If you have an ATC with this condition, correct it by installing an adjustable fender bracket kit as described below.

AFFECTED FRAME NUMBER RANGE:

319300 - 381603

1. Remove the existing screw and flat washer from the rear fender's front mounting hole.

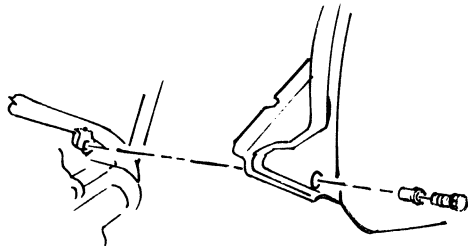

2. Install the adjustable fender bracket as shown, using the 6 x 12 mm flange bolt but don't tighten it yet.

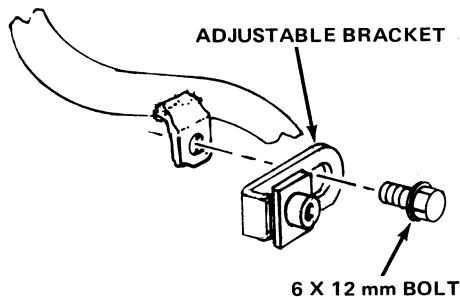

3. Install the new flat washer on the 6 x 10 mm phillips screw, then slip it partway into the rear fender's front mounting hole.
4. Turn the adjustable bracket so its threaded boss is properly aligned with the hole in the fender, then thread the phillips screw into the bracket but don't tighten it yet.
5. Tighten the 6 x 12 mm flange bolt from underneath, then tighten the 6 x 10 mm phillips screw.
6. Repeat steps 1 through 5 on the opposite side, if necessary.

PARTS INFORMATION

Adjustable Bracket Kit

H/C 1718261

P/N 50010-969-305

NOTE: The kit contains two adjustable brackets, two 6 x 12 mm flange bolts, two 6 x 10 mm phillips screws, and two flat washers.

(over)

ROUTING:

COPY 1

COPY 2

GENERAL MANAGER

SERVICE MANAGER

SALES DEPT.

MECHANICS

OFFICE FILE

SHOP MANUAL

NEW

WARRANTY INFORMATION

The normal 6-month, unlimited mileage warranty applies.

For installing one bracket, submit a warranty claim form with a flat rate time of 0.1 hours.

		JOB CODE - HRS TENTHS	
FAILED HONDA CODE	171826	C3-11	0.1
DEFECT CODE	074	TREATMENT CODE	2

For installing two brackets, submit a warranty claim form with a flat rate time of 0.2 hours.

		JOB CODE - HRS TENTHS	
FAILED HONDA CODE	171826	C3-11	0.2
DEFECT CODE	074	TREATMENT CODE	2

1984 ATC200ES FINAL GEAR CASE NOISE

Some customers may complain of abnormal noises coming from the rear axle area of their ATCs. The symptoms may be described as either a "grinding/creaking" sound or a "clicking/knocking" noise.

To verify the grinding/creaking condition, put the transmission in neutral and push the ATC. While pushing the ATC, turn the front wheel to the left or right. If the noise is present it will become louder when the wheel is turned.

To verify the clicking/knocking condition, raise the rear of the ATC and rotate the wheels by hand. A distinct "click" or "knock" may be heard three or four times for each complete wheel revolution.

In most cases, abnormal noises from the final drive can be eliminated by using the following procedure:

1. Loosen the inner and outer rear axle nuts.

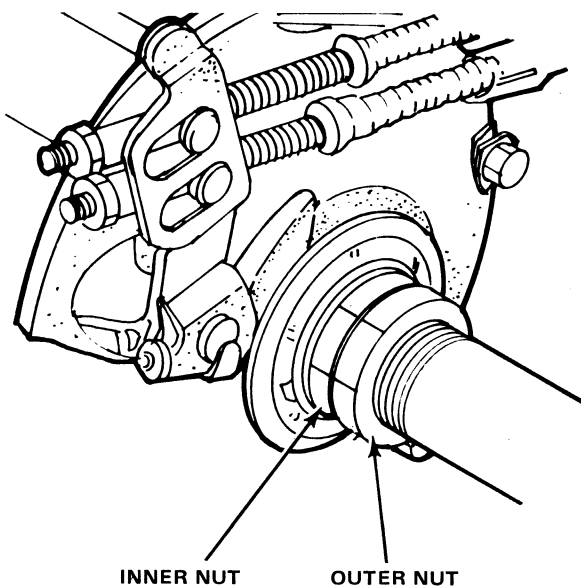

2. Use Axle Nut Adapter (T/N 07916-958110A) to torque the inner nut to 45 N·m (33 ft-lb).

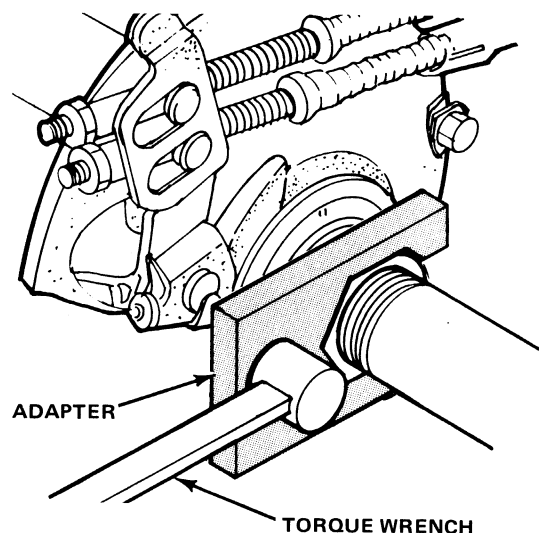

3. Apply Honda Anaerobic Thread Lock (H/C 1724418), or its equivalent, to the threads of the outer nut, then thread it onto the axle.
4. While holding the inner nut with Axle Nut Wrench (T/N 07916-958020A), use the Axle Nut Wrench to torque the outer nut to 130 N·m (94 ft-lb).

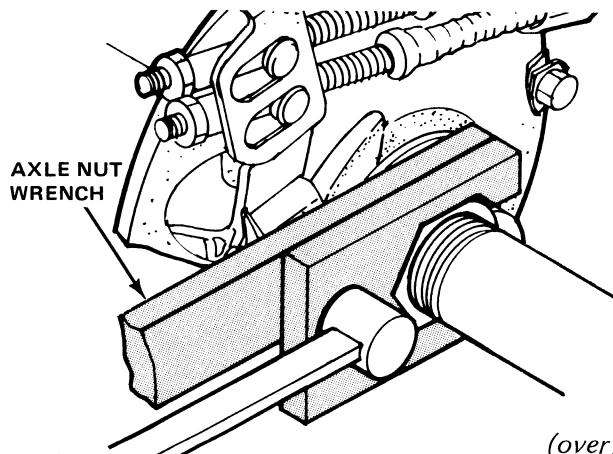

(over)

ROUTING:

COPY 1

COPY 2

GENERAL MANAGER

SERVICE MANAGER

SALES DEPT.

MECHANICS

OFFICE FILE

SHOP MANUAL

- Loosen the two mounting bolts for the final gear case, then push the ATC a few yards to allow the final gear case to center itself. Re-torque the mounting bolts to 60 N·m (49 ft-lb).

MOUNTING BOLTS

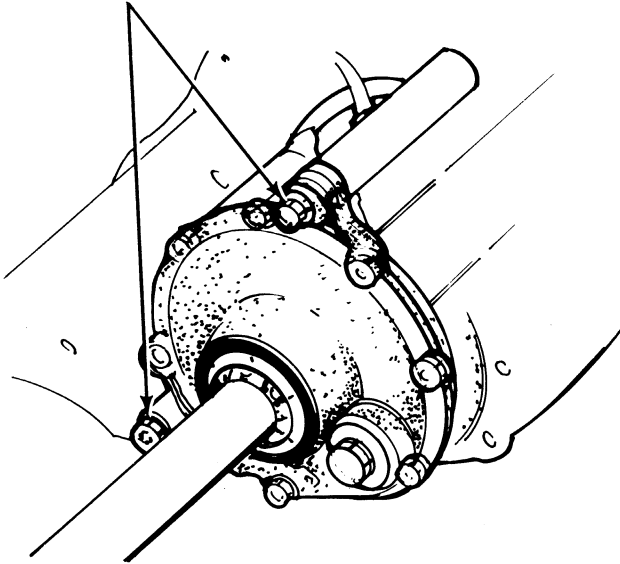

WARRANTY INFORMATION

The normal ATC warranty applies. Submit a warranty claim form for 0.3 hours total flat rate time. Use defect code 042.

FAILED HONDA CODE		JOB CODE - HRS TENTHS	
151903	03-15	0.3	
DEFECT CODE	TREATMENT CODE		
042	2		



SERVICE BULLETIN

AMERICAN HONDA MOTOR CO., INC. MOTORCYCLE SERVICE DEPARTMENT

1985/1986 ATC250ES REAR FENDER PROTECTORS

The rear fender protectors on some 1985/1986 ATC250ES' may work loose if they snag on objects as the ATV is being used.

To ensure that the fender protectors remain intact, a set screw and nut clip should be installed on new 1986 ATC250ES' during Pre-Delivery Inspection; 1985 models should have these additional parts installed whenever the ATV is returned for service.

AFFECTED ATV's

All 1985/1986 ATC250ES'

NOTE: On new 1986 models, install the set screw and nut clip during PDI.

INSTALLATION PROCEDURE

1. Remove the seat and both frame side covers.
2. Remove the two rear fender mounting knobs and lift up the rear fender. Then, prop up the fender by positioning the stopper arm into the hole in the fender.
3. Measure 20 mm *back* from the inside of the fender and scribe a mark. Then, measure 5.5 mm *in* from the outside edge and make another mark.

FENDER PROTECTOR
(Right side shown)

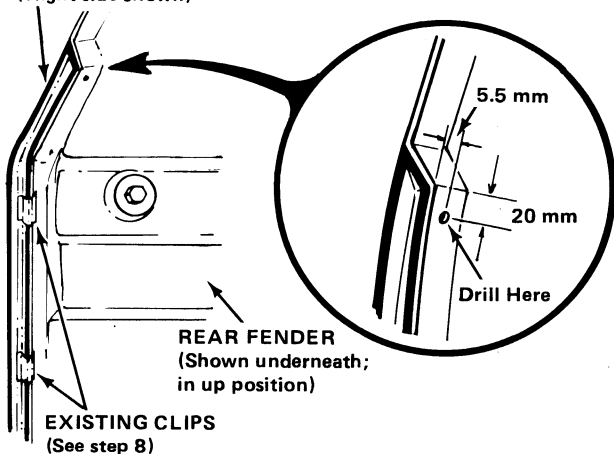

4. Without removing the fender protector, drill a small pilot hole (approximately 1 mm) through the fender and the protector at the point where the two marks intersect.

NOTE: Be careful NOT to drill through the OUTSIDE of the fender protector.

5. Re-drill and enlarge the pilot hole using a 6 mm drill bit, being careful not to drill through the outside of the protector.
6. Repeat the above steps for the other fender/ protector.
7. Install the new set screw and nut clip as shown.

FENDER PROTECTOR

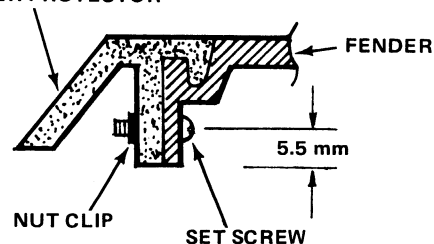

8. Inspect the fender protector clips on both fenders, making sure they are positioned as shown below.

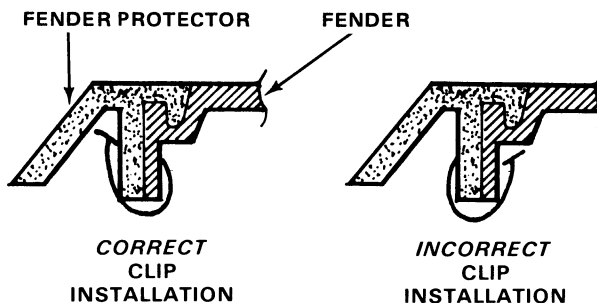

(over)

MTB 9344 (8510)

ROUTING:

COPY 1
COPY 2

GENERAL MANAGER
 SERVICE MANAGER

SALES DEPT.
 MECHANICS

OFFICE FILE
 SHOP MANUAL

PARTS INFORMATION

- Set Screw (2 required)
H/C: 1762145
P/N: 90107-KE8-700
- Nut Clip (2 required)
H/C: 1969583
P/N: 64527-KE8-700

WARRANTY INFORMATION

The normal warranty applies. If you feel that goodwill consideration is appropriate, contact your District Service Manager before starting the repair.

Submit a claim form with the following information:

Defect Code: 061
Failed Honda Code: 183761
Labor Operation Number: 413170
Flat Rate Time: 0.2 hours
Treatment Code: 1



ATC200ES #1
MARCH, 1984

1984 ATC200ES REQUIRED SPECIAL TOOLS

Six **NEW** Special Tools are required to service and maintain the 1984 ATC200ES. The new tools will be automatically shipped to you at a later date. The other tools listed below are also needed for this model, but have been introduced as required special tools for other models. If you don't already have these required tools, they can be ordered using normal ordering procedures. You must have these special tools or their approved equivalents in your dealership as per Paragraph 8.4 of the Motorcycle Sales Agreement.

ENGINE TOOLS

INSPECTION/ADJUSTMENT			
H/C	TOOL NUMBER	DESCRIPTION	APPLICABILITY
1230259	KS-AHM-32-003	Digital Multimeter	C.D.I. and voltage regulator inspection.
0238923	07401-0010000	Carburetor Float Level Gauge	Float level inspection.

CYLINDER HEAD/PISTON			
H/C	TOOL NUMBER	DESCRIPTION	APPLICABILITY
0915637	07742-0010100	Valve Guide Driver	Valve guide removal. Supersedes 07942-3290100, which can still be used.
0688150	07757-0010000	Valve Spring Compressor	Valve removal/installation. Supersedes 07957-3290001, which can still be used.
0332049	07984-0980000	Valve Guide Reamer, 5.47 mm	Valve guide I.D. sizing.

CLUTCH			
H/C	TOOL NUMBER	DESCRIPTION	APPLICABILITY
0647578	07716-0020100	Lock Nut Wrench, 20 x 24 mm	Clutch nut removal/torquing.
0753491	07746-0010200	Attachment, 37 x 40 mm	Right crankcase cover bearing #6203 installation. Use with 07746-0040400 and 07749-0010000.
0959890	07746-0040400	Pilot, 17 mm	
0933242	07749-0010000	Driver	
0413112	07936-3710100	Remover Handle	Right crankcase bearing #6203 removal.
0413120	*07936-3710200 (07741-0010201)	Remover Weight	
0413138	07936-3710300	Bearing Remover, 17 mm	

GENERATOR			
H/C	TOOL NUMBER	DESCRIPTION	APPLICABILITY
0060632	*07933-2000000 (07733-0010000)	Rotor Puller	Rotor removal.

TRANSMISSION/CRANKSHAFT			
H/C	TOOL NUMBER	DESCRIPTION	APPLICABILITY
0753509	07746-0010100	Attachment, 32 x 35 mm	<ul style="list-style-type: none"> Subtransmission cover countershaft bearing #6202 installation. Use with 07746-0040300, Pilot, 15 mm. Left crankcase mainshaft bearing #6202 installation.

* This tool is substituted for the tool in parenthesis. The tool in parenthesis is listed in the shop manual but is unavailable from American Honda Motor Co., Inc.

1 OF 4

MST 7209 8403

ROUTING	Copy 1:	<input type="checkbox"/> GENERAL MANAGER	<input type="checkbox"/> PARTS MANAGER	<input type="checkbox"/> TOOL CATALOG BINDER
	Copy 2:	<input type="checkbox"/> SERVICE MANAGER	<input type="checkbox"/> SERVICE TECHNICIANS	<input type="checkbox"/> SERVICE MANUAL BINDER

ENGINE TOOLS (CONTINUED)

TRANSMISSION/CRANKSHAFT (continued)				
H/C	TOOL NUMBER	DESCRIPTION	APPLICABILITY	
0753491	07746-0010200	Attachment, 37 x 40 mm	<ul style="list-style-type: none"> Subtransmission cover output drive gear shaft bearing #6203 installation. Use with 07746-0040400, Pilot, 17 mm. Output driven gear bearing holder bearing #5025 removal. Use with 07746-0040600, Pilot, 25 mm. 	
0959817	07746-0010300	Attachment, 42 x 47 mm	<ul style="list-style-type: none"> Output driven gear case bearing #6302 installation. Use with 07746-0040300, Pilot, 15 mm. Left crankcase countershaft bearing #0000 installation. Use with 07746-0040500, Pilot, 20 mm. 	
0753483	07746-0010400	Attachment, 52 x 55 mm	<ul style="list-style-type: none"> Output driven gear bearing holder, bearing #5025 installation. Use with 07746-0040600, Pilot, 25 mm. Right crankcase mainshaft bearing #6006 installation. Use with 07746-0040700, Pilot, 30 mm. 	
0959833	07746-0020100	Driver	Timing sprocket installation.	
0959841	07746-0020400	Attachment, 20 mm I.D.		
0753459	07746-0030100	Driver	Use with 07746-0030200 and 07746-0030300.	
0959858	07746-0030200	Attachment, 25 mm I.D.	<ul style="list-style-type: none"> Support the inner bearing race when installing the output driven gear into the bearing holder. Oil pump drive gear installation. Use with 07746-0030100. 	
0813113	07746-0030300	Attachment, 30 mm I.D.	<ul style="list-style-type: none"> Support the inner bearing race when installing the output drive gear into the bearing. Use with 07746-0030100. Crankshaft bearings #6328 installation. Use with 07746-0030100. 	
0959882	07746-0040300	Pilot, 15 mm	<ul style="list-style-type: none"> Use with 07746-0010100 to install the countershaft bearing into the sub-transmission cover. Use with 07746-0010300 to install the driven gear bearing into the output gear case. 	
0959890	07746-0040400	Pilot, 17 mm	Use with 07746-0010200 to install the output drive gear shaft bearing into the subtransmission cover.	
1252816	07746-0040500	Pilot, 20 mm	Use with 07746-0010300 to install the countershaft bearing into the left crankcase.	
0959916	07746-0040600	Pilot, 25 mm	<ul style="list-style-type: none"> Use with 07746-0010200 to remove the output driven gear bearing from the bearing holder. Use with 07746-0010400 to install the output driven gear bearing into the bearing holder. 	
1021252	07746-0040700	Pilot, 30 mm	Use with 07746-0010400 to install the mainshaft bearing into the right crankcase.	
0933242	07749-0010000	Driver	Use with attachments and pilots.	
1382977	07916-ME50000	Lock Nut Wrench, 34/44 mm	<ul style="list-style-type: none"> Output drive gear inner bearing race lock nut removal and torquing. Use with 07916-9690100 to remove and torque the output drive gear outer bearing race lock nut. 	
NEW	1732304	07916-9690000	Lock Nut Wrench, 30/40 mm	Output driven gear inner and outer bearing race lock nuts removal and torquing.
NEW	1732296	07916-9690100	Lock Nut Wrench Attachment, 50 mm	Output drive gear outer bearing race lock nut removal and torquing. Use with 07916-ME50000.
0809772	07923-6890101	Shaft Holder	Hold output drive and driven gears to assist inner bearing races lock nut removal and torquing.	
1724475	07936-KC10500	Bearing Remover, 15 mm	<ul style="list-style-type: none"> Countershaft bearing #6202 removal from subtransmission cover. Output drive gear bearing #6302 removal from output gear case. Mainshaft bearing #6202 removal from left crankcase. Use with 07936-3710100 and 07936-3710200. 	

ENGINE TOOLS (CONTINUED)

TRANSMISSION/CRANKSHAFT (continued)

H/C	TOOL NUMBER	DESCRIPTION	APPLICABILITY
0413112	07936-3710100	Bearing Remover Handle	Use together with bearing removers.
041312Q	*07936-3710200 (07741-0010201)	Bearing Remover Weight	
0413138	07936-3710300	Bearing Remover, 17 mm	Output drive gear shaft bearing #6203 removal from subtransmission cover. Use with 07936-3710100 and 07936-3710200.

FINAL DRIVE

H/C	TOOL NUMBER	DESCRIPTION	APPLICABILITY
0753509	07746-0010100	Attachment, 32 x 35 mm	Pinion gear case needle bearing installation.
0959825	07746-0010500	Attachment, 62 x 68 mm	Ring gear case bearing #6909 installation.
1501121	07746-0010600	Attachment, 72 x 75 mm	<ul style="list-style-type: none"> ● Ring gear case cover bearing #6009 installation. ● Ring gear case oil seal installation.
0959833	07746-0020100	Driver, 22 mm I.D.	Pinion gear bearing installation.
0753459	07746-0030100	Driver	Pinion assembly installation into case.
0933242	07749-0010000	Driver	Use with attachments.
1440684	07910-ME80000	Pinion Gear Retainer Wrench	Pinion gear retainer removal/torquing.
1432103	07924-ME40000	Pinion Holder	Hold pinion gear to assist pinion gear shaft nut removal/torquing. Must be used with attachment 07924-9690101 to protect surface of case.
NEW 1742717	07924-9690101	Pinion Holder Attachment	Use with pinion holder 07924-ME40000 to protect the case surface.
1432111	07931-ME40000	Shaft Puller	Pinion gear removal from case. Used with pinion holder and attachment.
0478834	07945-3710101	Driver	Drive shaft oil seal guide and oil seal installation.
1210988	07946-3710701	Attachment	Pinion gear retainer oil seal installation. Use with Driver 07749-0010000. Attachment 07946-3710700 may also be used.
NEW 1732254	07967-9690200	Compressor Seat	Use with commercially available puller for disassembly and assembly of drive shaft/damper. See Tool Usage STN for details.
0782813	*90010-371-003 (07965-ME30000)	Flange Bolt, 10 x 160 mm	Drive shaft damper lifter removal. Position the head of the bolt through the damper case and against the damper lifter, then drive the lifter out.

CHASSIS TOOLS

WHEEL/BRAKE

H/C	TOOL NUMBER	DESCRIPTION	APPLICABILITY
1411941	GN-AH-958-BB1	Universal Bead Breaker	To break tire bead from rim.
0959817	07746-0010300	Attachment, 42 x 47 mm	Front wheel bearing #6302 installation. Use with 07746-0040300, Pilot, 15 mm.
0959825	07746-0010500	Attachment, 62 x 68 mm	<ul style="list-style-type: none"> ● Rear brake cover wheel bearing #6909 installation. ● Rear brake cover and drum case dust seal installation.
0959882	07746-0040300	Pilot, 15 mm	Use with attachment 07746-0010300.
0933242	07749-0010000	Driver	Use with attachment and pilot to install bearings.
NEW 1779222	*07916-958010A (07916-9580400)	Axle Nut Torque Wrench Adapter	Use with a torque wrench to torque both the inner and outer axle nuts.
NEW 1779230	*07916-958020A (07916-9580200)	Axle Nut Holder Wrench	Use to hold the inner axle nut while torquing the outer axle nut.

SUSPENSION/FRAME

H/C	TOOL NUMBER	DESCRIPTION	APPLICABILITY
0917740	M9360-277-91774	Bearing Remover	Steering race (upper & lower) removal. Replaces 07944-1150001 which can still be used.
0997882	M9361-412-099788	Adjustable Pin Spanner Wrench	Steering stem top thread nut removal/adjustment. Replaces 07902-0010000 which can still be used.

* This tool is substituted for the tool in parenthesis. The tool in parenthesis is listed in the shop manual but is unavailable from American Honda Motor Co., Inc.

CHASSIS TOOLS (CONTINUED)

SUSPENSION/FRAME (continued)			
H/C	TOOL NUMBER	DESCRIPTION	APPLICABILITY
0753491	07746-0010200	Attachment, 37 x 40 mm	Steering race (upper & lower) installation.
0933242	07749-0010000	Driver	Use with attachment 07746-0010200.
0688168	07959-3290001	Rear Shock Spring Compressor	Front fork damper spring removal and installation.

SPECIAL INFORMATION

The tools listed below are necessary to service and repair this model. However, these tools are not available from American Honda Motor Co., Inc. and must be purchased from other sources.

DESCRIPTION	APPLICABILITY
ATV Tire Repair Kit	See General STN #26 for ordering details.
30 mm Deep Socket	Centrifugal clutch lock nut removal and torquing. NOTE: Lock nut has left hand threads.

AMERICAN HONDA MOTOR CO., INC.
SERVICE DEPARTMENT