



# YAMAHA

# YT 60L

## Service Manual



**YAMAHA**

Yamaha Motor Company

11400 W. Higgins Rd.

Skokie, IL 60076

USA

© 1999

11400 W. Higgins Rd.

**YT60L**

**Service Manual**

# INDEX

<b>GENERAL INFORMATION</b>	<b>1</b>
<b>PERIODIC INSPECTIONS AND ADJUSTMENTS</b>	<b>2</b>
<b>ENGINE OVERHAUL</b>	<b>3</b>
<b>CARBURETION</b>	<b>4</b>
<b>CHASSIS</b>	<b>5</b>
<b>ELECTRICAL</b>	<b>6</b>
<b>APPENDICES</b>	<b>7</b>

# CHAPTER 1. GENERAL INFORMATION

<b>MACHINE IDENTIFICATION</b> .....	1-1
Frame Serial Number .....	1-1
Engine Serial Number .....	1-1
<b>SPECIAL TOOLS</b> .....	1-2
For Tune-up .....	1-2
For Engine Service .....	1-2
For Chassis Service .....	1-3
For Electrical Components .....	1-4

# CHAPTER 1. GENERAL INFORMATION

## MACHINE IDENTIFICATION

### Frame Serial Number

The frame serial number is stamped into the right-side of the steering head pipe.



1. Frame serial number

### NOTE:

The first three digits of these numbers are for model identification; the remaining digits are the unit production number.

### Engine Serial Number

The engine serial number is stamped into the elevated part of the right rear section of the engine.

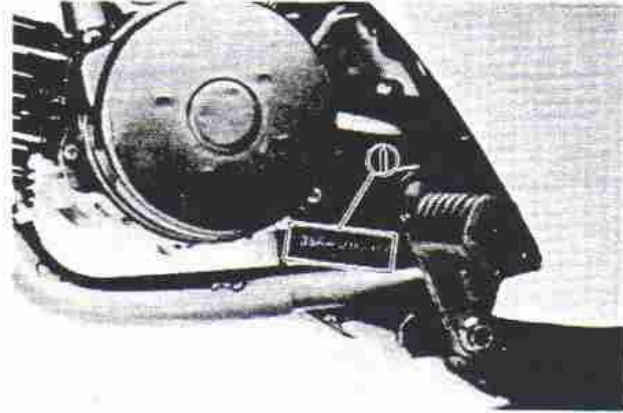

1. Engine serial number

### Starting Serial Number:

YT60L .....36R-000101



## SPECIAL TOOLS

The proper special tools are necessary for complete and accurate tune-up and assembly. Using the correct special tool will help prevent damage caused by the use of improper tools or improvised techniques.

### For Tune-up

Inductive Tachometer

P/N. YU-08036

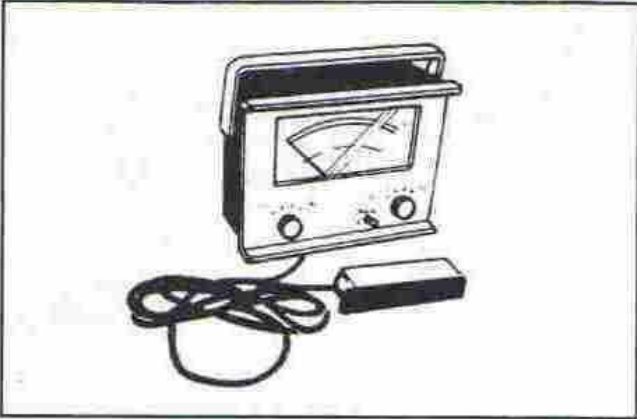

Inductive Timing Light

P/N. YU-08037

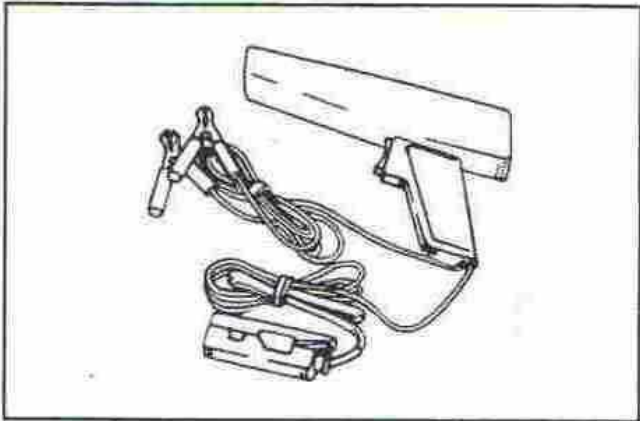

### For Engine Service

Dial Gauge

P/N. YU-03097

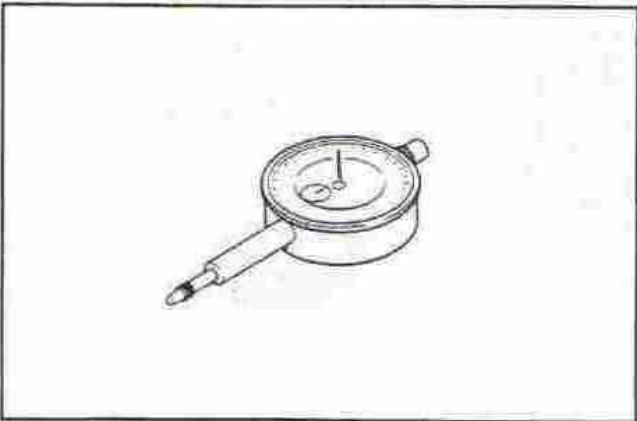

Extension Tip

P/N. YU-01256

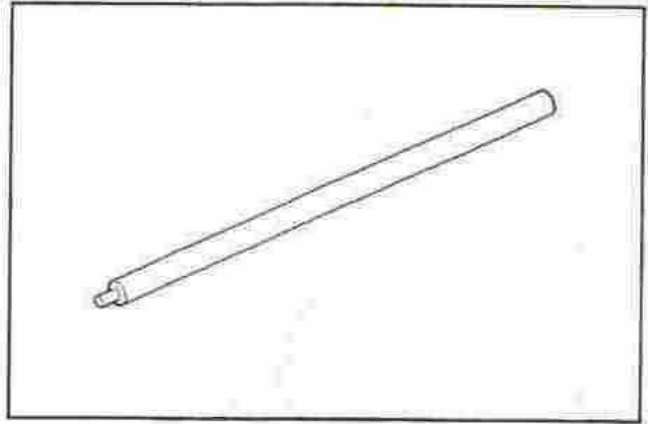

These tools are used to check and adjust the oil pump minimum stroke.

Universal Puller

P/N. YU-33270

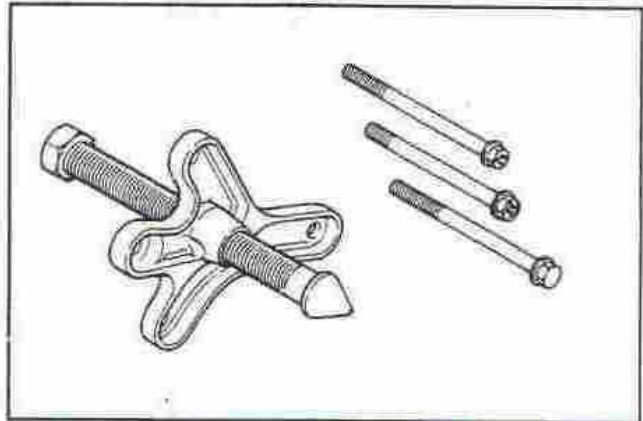

This tool is used to remove the crankshaft from the crankcase.

Crankshaft Installation Set

P/N. YU-90050

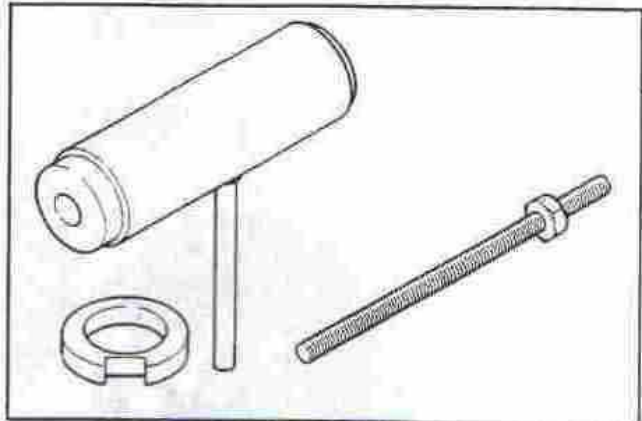

**Crankshaft Installer Bolt Adapter Set**  
P/N. YU-90051

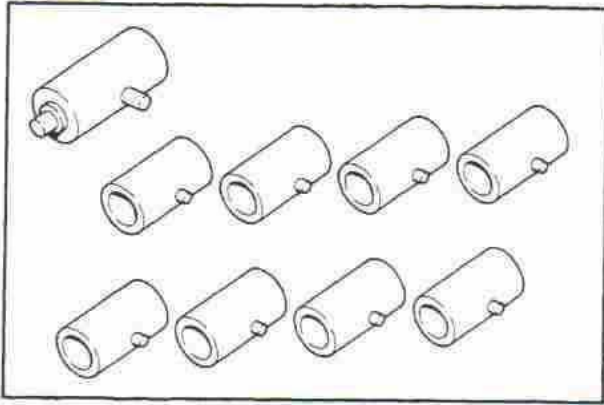

These tools are used to install the crankshaft.

**Flywheel Puller**  
P/N. YM-01189

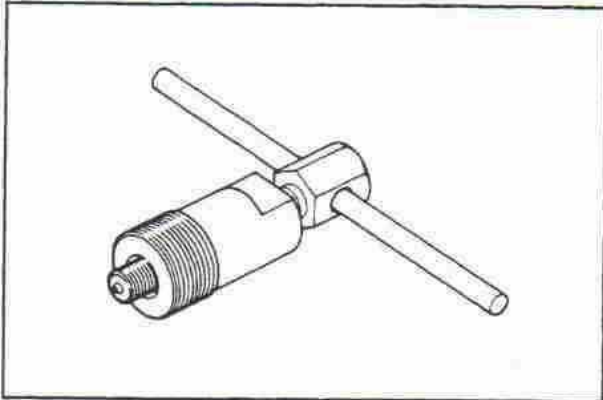

This tool is used to remove the flywheel magneto.

**Flywheel Holding Tool**  
P/N. YU-01235

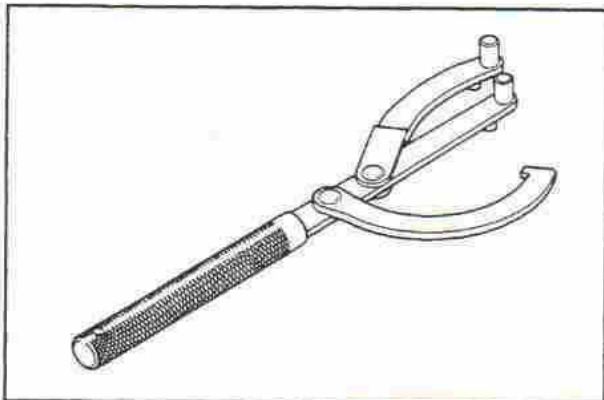

Use this tool to hold the flywheel magneto while removing or tightening the flywheel magneto securing nut.

**Hexagon Wrench (25 MM)**  
P/N. YM-01306

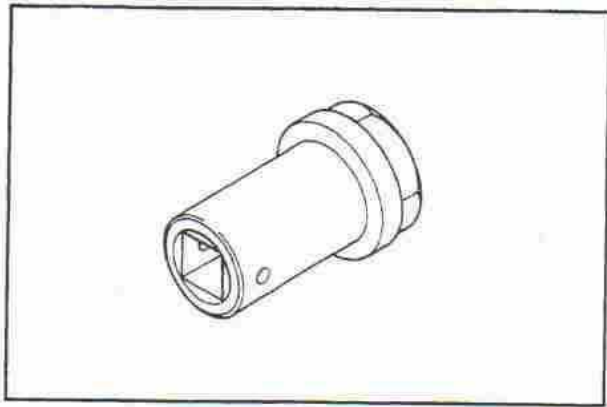

Use this tool to loosen or tighten the middle-driven-shaft-bearing retainer nut.

**Hexagon Wrench (22 MM)**  
P/N. YM-01307

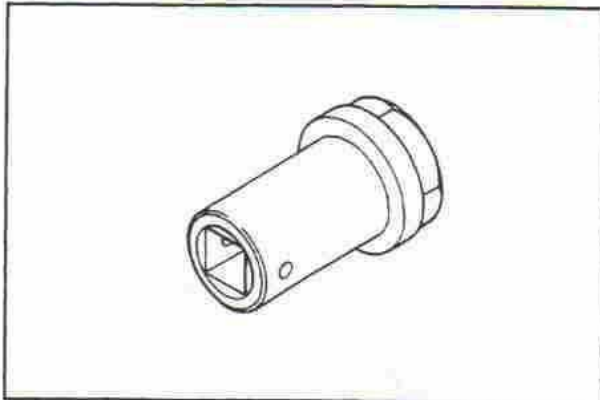

Use this tool to loosen or tighten the final-drive-shaft-bearing retainer nut.

**For Chassis Service**  
**Steering Nut Wrench**  
P/N. YU-01268

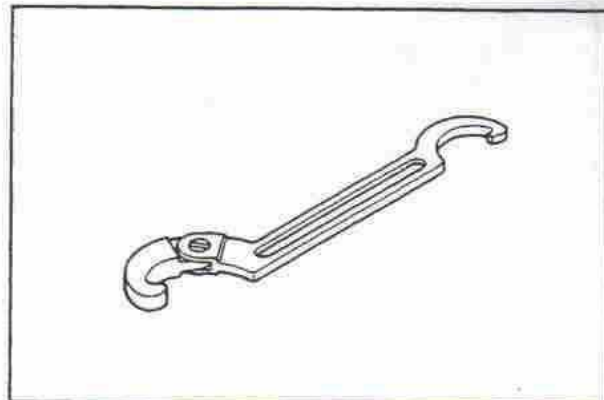

Use this wrench to tighten or loosen the ring nut on the rear axle.

## For Electrical Components

The use of these tools are described in Chapter 6.

### Electro Tester Kit

P/N. YU-33260

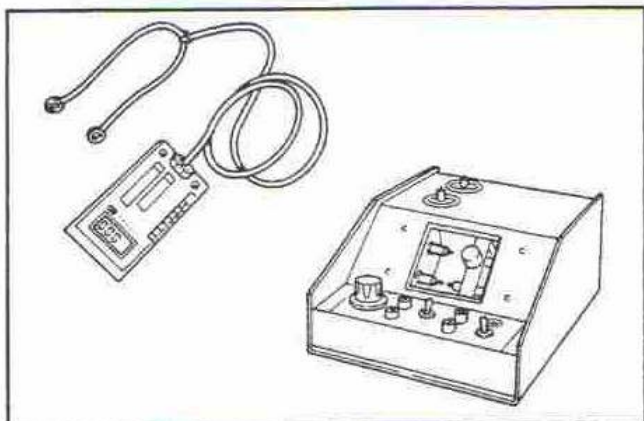

This kit includes Coil tester and digital Volt-Ohm meter.

### or Pocket Tester

P/N. YU-03112

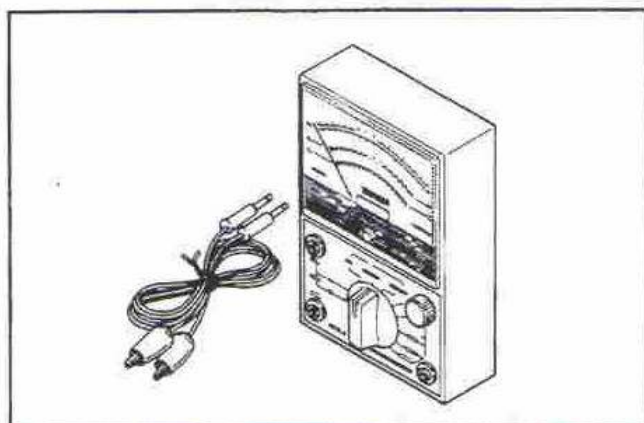

### or Electro Tester

P/N. YU-03021

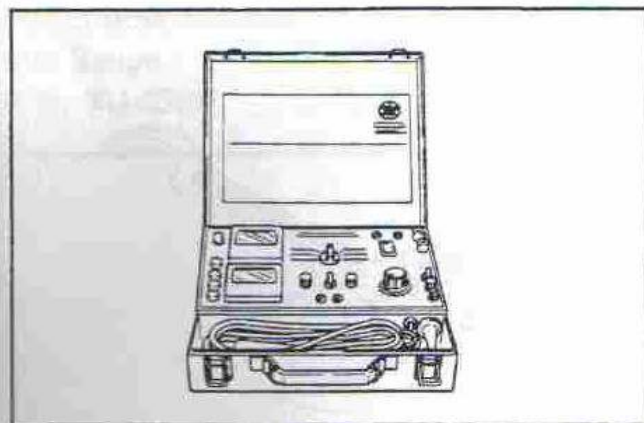



# CHAPTER 2. PERIODIC INSPECTIONS AND ADJUSTMENTS

INTRODUCTION .....	2-1
MAINTENANCE INTERVALS CHARTS .....	2-1
PERIODIC MAINTENANCE.....	2-1
LUBRICATION INTERVALS .....	2-1
<b>ENGINE</b> .....	<b>2-2</b>
Spark Plug .....	2-2
Fuel Line .....	2-2
Idle Speed .....	2-2
Throttle Cable .....	2-2
Throttle Lever.....	2-3
Starter (Choke) Lever and Cable.....	2-3
Autolube Pump Cable Adjustment.....	2-4
Air Bleeding .....	2-5
Engine Oil .....	2-6
Transmission Oil .....	2-6
Checking Ignition Timing .....	2-7
<b>CHASSIS</b> .....	<b>2-7</b>
Air Filter Cleaning .....	2-7
Brake Adjustment .....	2-8
Brake Lining Inspection .....	2-8
Steering Head Adjustment .....	2-9
Wheel Bearings .....	2-10
Fuel Cock .....	2-10
Tires .....	2-11
Cable Inspection and Lubrication .....	2-11

# CHAPTER 2. PERIODIC INSPECTIONS AND ADJUSTMENTS

## INTRODUCTION

This chapter includes all information necessary to perform recommended inspections and adjustments. These preventive maintenance procedures, if followed, will ensure more reliable vehicle operation and a longer service life. The need for costly overhaul work will be greatly reduced. This information applies to vehicles already in service and to new vehicles that are being prepared for sale. All service technicians should be familiar with this entire chapter.

## MAINTENANCE INTERVALS CHARTS

The following charts should be considered strictly as a guide to general maintenance and lubrication intervals. You must take into consideration that weather, terrain, geographical location, and a variety of individual uses. This time schedule should be altered to match individual owner's requirements. For example, if the machine is continually operated in an area of high humidity, then all parts must be lubricated much more frequently than shown on the chart to avoid damage caused by water to metal parts.

### PERIODIC MAINTENANCE

Item	Remarks	Initial			Thereafter every	
		1 Month	4 Months	7 Months	6 Months	1 Year
Cylinder head/ Exhaust system/ Spark arrester	Decarbonize		○	○	○	
Spark plug	Inspect/ Cleaning or replace as required	○	○	○	○	
Air filter	Wet type- Must be washed and damped with Yamalube 2-cycle Oil or air cooled 2-cycle engine oil		○	○	○	
Carburetor	Check operation/ Fittings		○	○	○	
	Clean/ Refit/ Adjust					○
Autolube pump	Clean/ Check/ Adjust/ Air bleeding	○	○	○	○	
* Brake system (complete)	Check/ Adjust as required- Repair as required	○	○	○	3 Months	
* Wheels and tires	Check pressure/ Wear/ Balance/ Run out	○	○	○	○	
Fuel cock	Clean/ Flush tank as required	○	○	○	○	
* Fittings/ Fasteners	Tighten before each trip and/ or...	○	○	○	○	

\*Indicates pre-operation check items.

### LUBRICATION INTERVALS

Item	Remarks	Type	Initial			Thereafter every	
			1 Month	4 Months	7 Months	6 Months	1 Year
* Transmission oil	Replace/ Warm engine before draining	Yamalube 4-cycle oil or SAE 10W30 type SE motor oil	○	Check	○	○	
Throttle lever and housing	Apply lightly	Lithium base grease			○	○	
Brake lever	Apply lightly	Lithium base grease		○	○	○	
Brake cam shaft	Apply lightly	Lithium base grease		○	○	○	
Steering bearings	Inspect thoroughly/ pack moderately	Medium-weight wheel bearing grease			Check		2 Years
Wheel bearings	Do not over-pack yearly or...	Medium-weight wheel bearing grease					○

\*Indicates pre-operation check items.

## ENGINE

### Spark Plug

1. Check electrode condition and wear, insulator color, and electrode gap.
2. Clean the spark plug with spark plug cleaner if necessary. Use a wire gauge to adjust the plug gap to the specification.
3. If the electrode becomes too worn, replace the spark plug.
4. When installing the plug, always clean the gasket surface, wipe off any grime that might be present on the surface of the spark plug, and torque the spark plug properly.

Standard Spark Plug:

BP6HS (NGK) or W20FP-U  
(NIPPONDENSO)

Spark Plug Gap:

0.6~0.7 mm (0.028~0.031 in)

Spark Plug Tightening Torque:

20 Nm (2.0 m·kg, 14 ft·lb)

### Fuel Line

Check the fuel hose for cracks or damage; replace if necessary.

### Idle Speed

1. Turn the pilot air screw until it lightly seats, then back it out to specification. This adjustment can be made with engine stopped.

Pilot Air Screw: 2 turns out

2. Start the engine and let it warm up.
3. Throttle stop screw  
Turn throttle stop screw in or out to achieve smooth engine operation at specified idle speed.

Idling Speed: 1,700 r/min

### NOTE:

The pilot air and throttle stop screws are separate adjustments but they must be adjusted at the same time to achieve optimum operating condition at engine idle speeds.

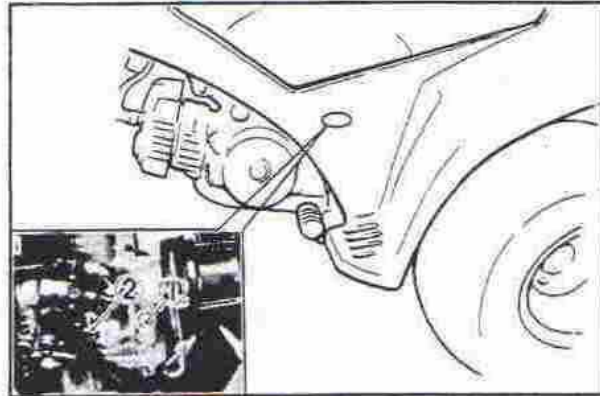

1. Pilot air screw 2. Throttle stop screw

### Throttle Cable

1. Remove the seat and body cowl assembly.

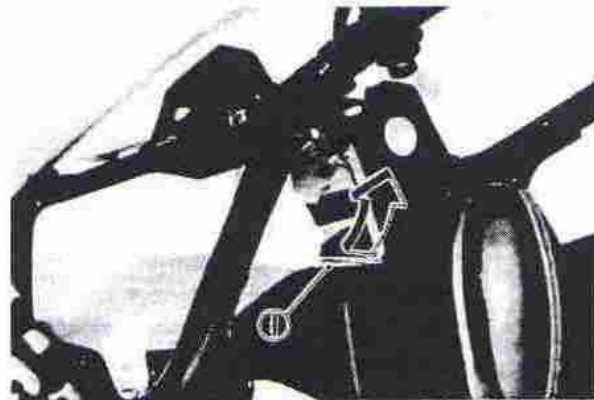

1. Seat lock lever



- Loosen the throttle cable adjuster locknut (at top of carburetor) and turn cable adjuster until specified free play is obtained. Retighten locknut.

Free Play: 1.0 mm (0.04 in)

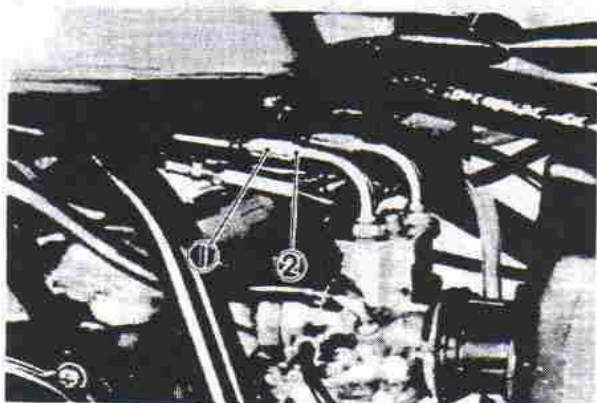

1. Adjuster 2. Locknut

### Throttle Lever

Loosen the locknut and turn the adjuster until there is the specified free play at throttle lever.

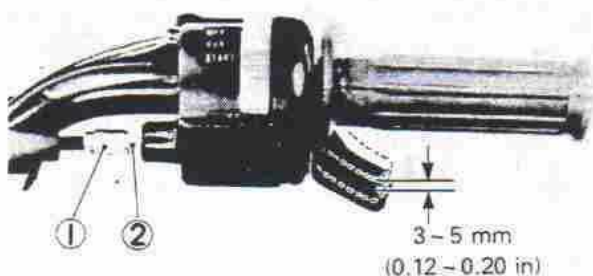

1. Adjuster 2. Locknut

Throttle Lever Play:  
3-5 mm (0.12-0.20 in)

### Starter (Choke) Lever and Cable

Use the starter lever (CHOKE) by reference to the figure below:

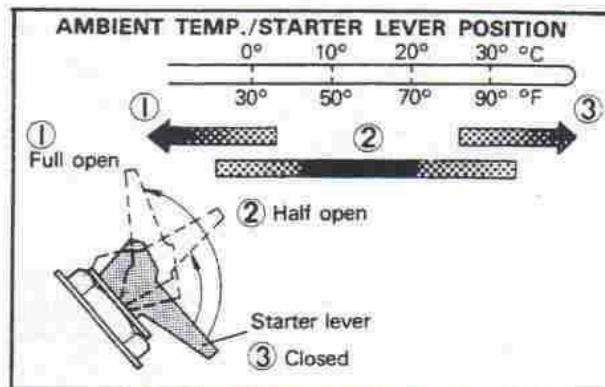

- position: Cold engine start-ambient temp. below 5°C (40°F)
- position: Cold engine start-ambient temp. at 0°C (30°F) ~ 30°C (90°F) and warming up position.
- position: Cold engine start-ambient temp. above 25°C (80°F) and warm engine start position.

### NOTE:

- After the engine started at the ① position, the starter lever is returned to the half open position ② for warming up the engine. If the engine started at the ② position, keep this position ② for warming up the engine.
- Continue warming up the engine until it idles smoothly and return the starter lever to the original position ③ for riding.

### Starter (Choke) Cable Adjustment

- Remove the seat and body cowl assembly.
- Remove the air filter case assembly.
- Turn the starter lever to the half open (②), then check to see that the bottom of the starter plunger piston is aligned with the top of the starter outlet hole as shown in the photograph.

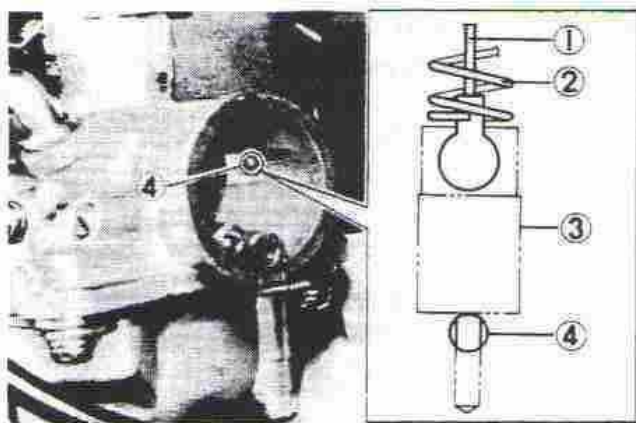

1. Starter Cable
2. Spring
3. Starter plunger piston
4. Starter outlet hole

4. If the starter plunger position is not correct, loosen the cable length adjuster locknut and adjust the cable length until alignment is achieved.

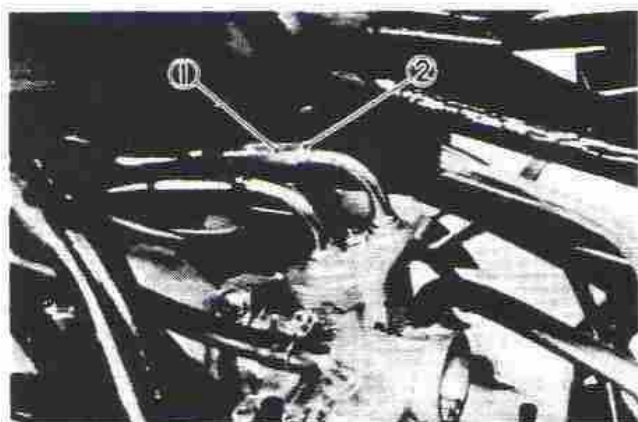

1. Cable adjuster
2. Locknut

### Autolube Pump Cable Adjustment

Before adjusting the pump cable, adjust the throttle cable free play.

1. Remove the seat and body cowl assembly.
2. Adjust the throttle cable free play of 1.0 mm (0.04 in) at the cable adjuster on the carburetor.
3. Remove the Autolube pump cover.

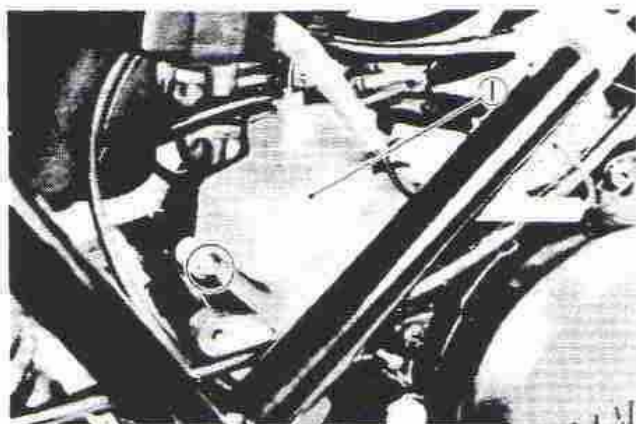

1. Cover

4. Close the throttle lever completely, then check to see that the Autolube pump plunger pin is aligned with the mark on the Autolube pump pulley.

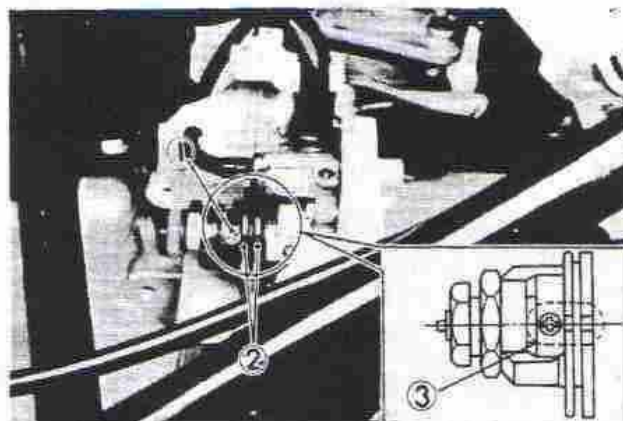

1. Plunger pin
2. Mark
3. Set position

5. If the mark and pin are not in alignment, loosen the cable length adjuster locknut and adjust cable length until alignment is achieved.

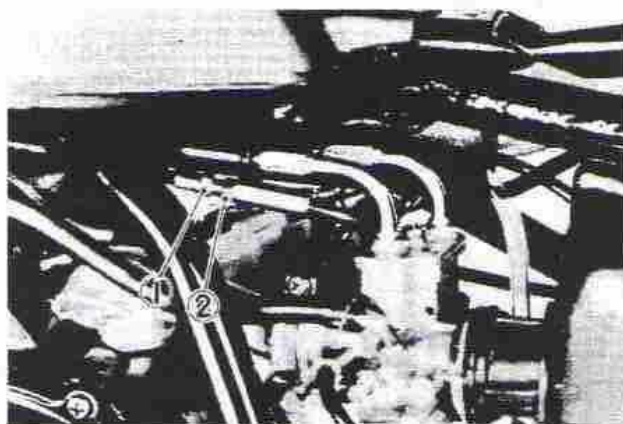

1. Cable adjuster
2. Locknut

6. Tighten adjuster locknut.

### Minimum Pump Stroke Check and Adjustment

1. Remove the muffler securing bolts and remove the muffler assembly.

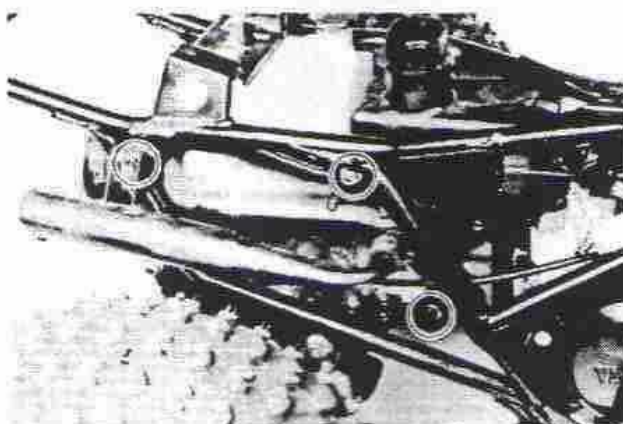

- Set the magnetic stand and dial gauge, and measure the pump stroke while keeping the engine idle.

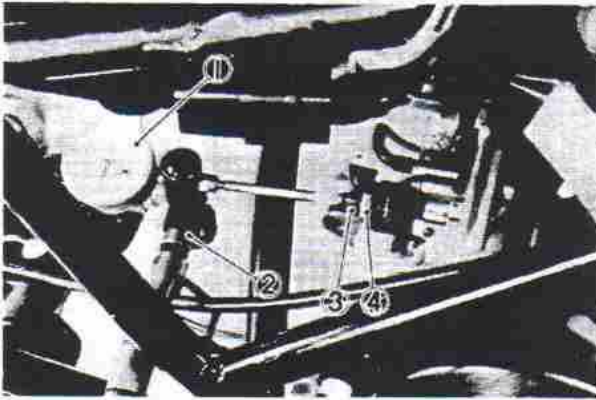

- Dial gauge
- Magnetic stand
- Adjuster
- Locknut

- To adjust the plunger stroke, first loosen the locknut.
- Turn the adjusting bolt in or out for proper adjustment.  
Turning the adjusting bolt clockwise decreases the plunger stroke; while turning counterclockwise increases the plunger stroke.
- When the correct stroke is attained, tighten the locknut.

Minimum Stroke	0.25 ~ 0.30 mm (0.010 ~ 0.012 in)
Maximum Stroke	1.00 ~ 1.15 mm (0.039 ~ 0.045 in)
Pulley Color Code	Yellow
Pulley Adjust Mark	

- Install the muffler and torque the bolts to specification.

#### TIGHTENING TORQUE:

Muffler:

27 Nm (2.7 m·kg, 19 ft·lb)

Muffler clamp:

20 Nm (2.0 m·kg, 14 ft·lb)

- Install the Autolube pump cover, body cowl assembly, and seat.

## Air Bleeding

The Autolube pump and delivery lines must be bled on the following occasions:

- Whenever the Autolube tank has run dry.
  - Whenever any portion of the Autolube system is disconnected.
  - If the machine lies on its side after falling over.
- Remove the pump cover and remove the bleed screw.

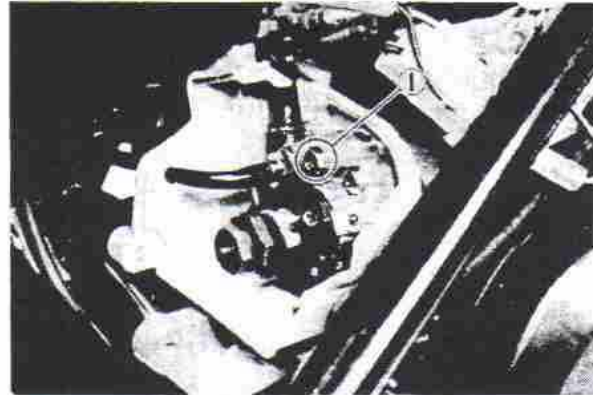

- Bleed screw
- Keep the oil running out until air bubbles disappear.

#### NOTE:

Check the bleed screw gasket, and if damaged, replace with a new one.

- When air bubbles are expelled completely, tighten the bleed screw and install the pump cover.
- Start the engine, pull the pump wire all the way out to set the pump stroke to a maximum.

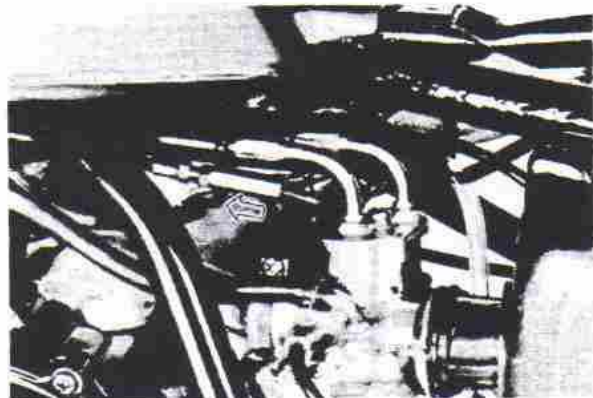

**NOTE:**

It is difficult to bleed the distributor completely with the pump stroke at a minimum, and therefore the pump stroke should be set to a maximum.

5. Keep the engine running at about 2,000 r/min for two minutes or so, and both distributor and delivery pipe can be completely bled.

**Engine Oil**

Check the engine oil level in the oil tank. If the oil level is low, add the sufficient oil.

**Recommended Oil:**

Yamalube 2-Cycle Oil or Air-Cooled 2-Stroke Engine Oil

**Oil Tank Capacity:**

0.7 L (0.62 Imp qt, 0.74 US qt)

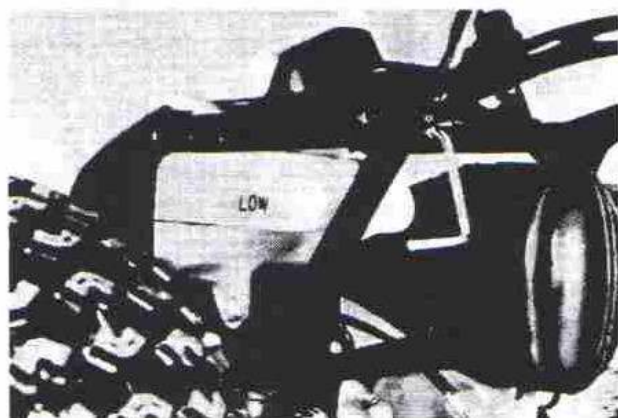

**NOTE:**

Install the oil tank filler cap and push it fully into the filler.

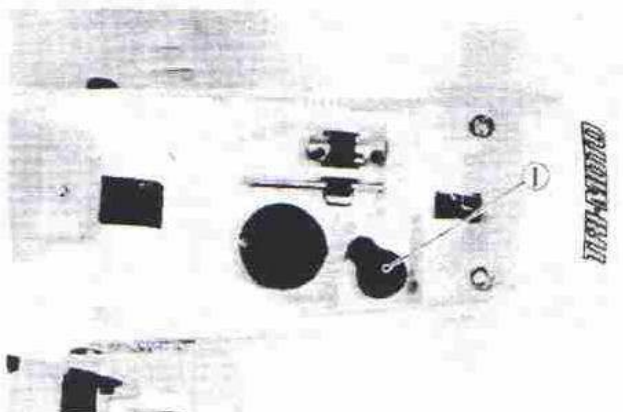

1. Oil tank filler cap

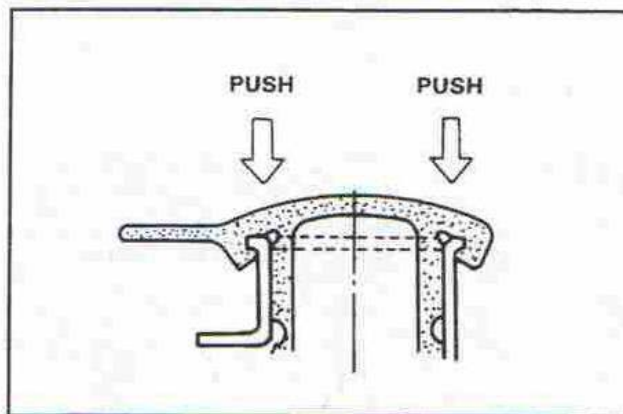

**Transmission Oil**

To drain the oil, warm the engine up and remove the drain plug and drain all transmission oil. Reinstall the drain plug (make sure it is secure). Add oil through the filler cap.

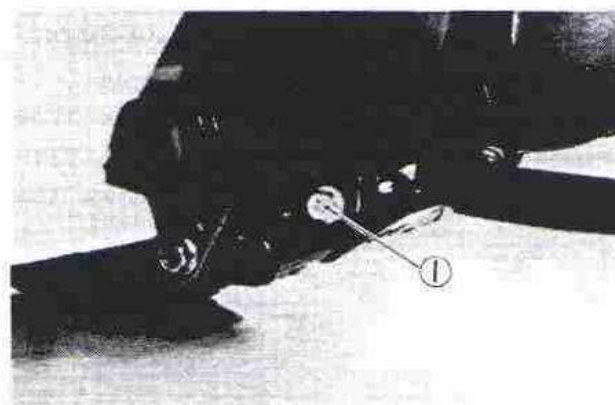

1. Drain plug

**TIGHTENING TORQUE:**

18 Nm (1.8 m·kg, 13 ft·lb)



1. Filler cap

**Recommended Oil:**

Yamalube 4-Cycle Oil or SAE 10W30  
Type SE Motor Oil

**Transmission Oil Capacity:**

**Periodic Oil Change:**

0.30 L (0.26 Imp qt, 0.32 US qt)

**Total Amount:**

0.35 L (0.31 Imp qt, 0.37 US qt)

**Checking Ignition Timing**

1. Ignition timing is checked with timing light by observing the position of the stationary pointer marked on the crankcase and the marks on the flywheel magneto.

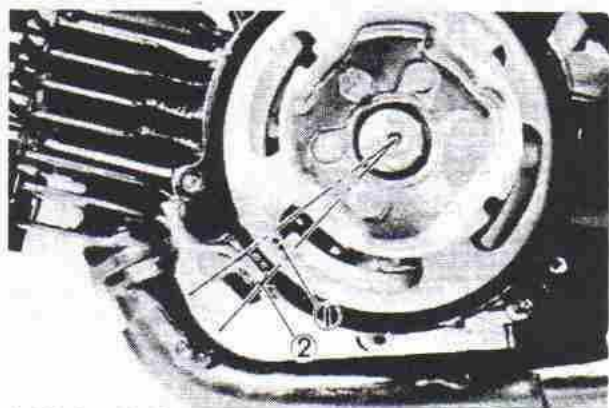

1. Mark 2. Stationary pointer

2. Remove the crankcase cover (L).
3. Connect the timing light to the spark plug lead.
4. Start the engine and keep it running at the specified speed. Use a tachometer for checking.

**Specified Engine Speed:**

1,600 ± 50 r/min

5. While running the engine at the specified speed, check to see that the stationary pointer is aligned with the magneto center mark. If the marks are out of alignment, check the woodruff key for damage and/or crankshaft for damage.

**CHASSIS**

**Air Filter Cleaning**

1. Remove the pan head screw from the filter case.

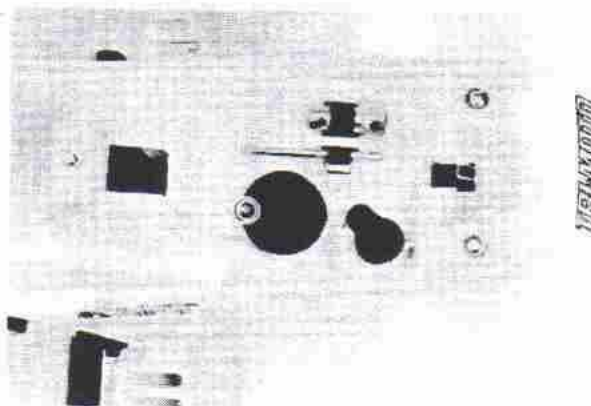

2. Pull out case cap.
3. Remove the element from the case cap.

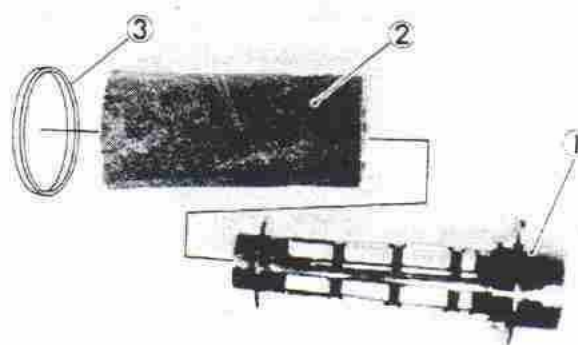

1. Case cap 2. Element 3. Band

4. Wash the element gently, but thoroughly, in solvent.
5. Squeeze the excess solvent out of the filter and let dry.
6. Pour a small quantity of foam-air-filter oil or Air-cooled 2-stroke engine oil onto the filter element and work thoroughly into the porous foam material.

**NOTE:** \_\_\_\_\_

In order to function properly, the element must be damp with oil at all times, but not dripping with oil.



7. Reinstall the element assembly and parts removed for access.

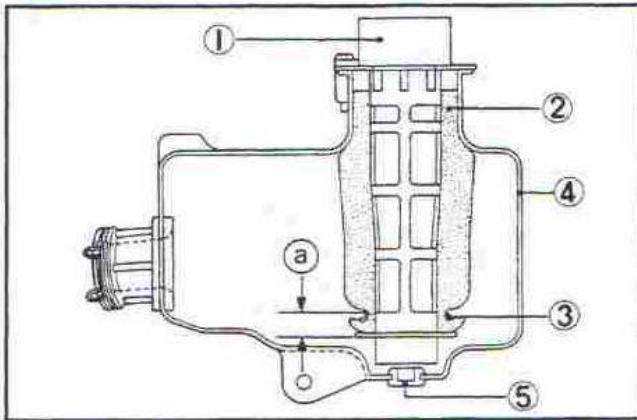

- |             |                           |
|-------------|---------------------------|
| 1. Case cap | 4. Air filter case        |
| 2. Element  | 5. Drain plug             |
| 3. Band     | a. 7-10 mm (0.28-0.40 in) |

**NOTE:**

Each time filter element maintenance is performed, check the air inlet to the filter case for obstructions. Check the air cleaner joint rubber to the carburetor and carburetor joint fittings and drain plug for an air-tight seal. Tighten all fittings thoroughly to avoid the possibility of unfiltered air entering the engine.

**CAUTION:**

Never operate the engine with the air filter element removed. This will allow unfiltered air to enter, causing rapid wear and possible engine damage. Additionally, operation without the filter element will affect carburetor jetting with subsequent poor performance and possible engine overheating.

Be careful not to have rags or the like blocking the intake area of the air filter.

**Brake Adjustment**

Brake cable free play can be adjusted to suit rider preference, but a minimum free play of 5-8 mm (0.2-0.3 in) should be maintained.

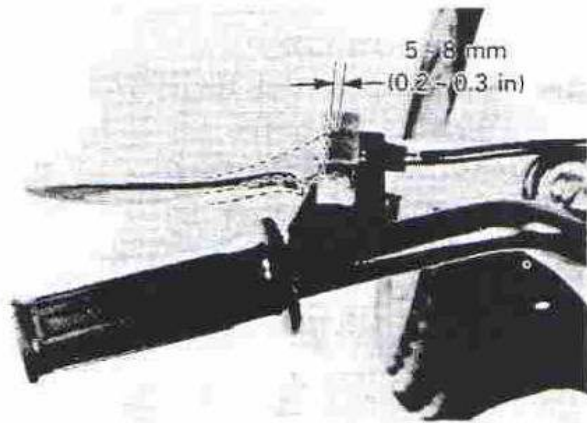

Free play can be adjusted at brake shoe plates. Turn the adjuster in or out until proper adjustment is achieved.

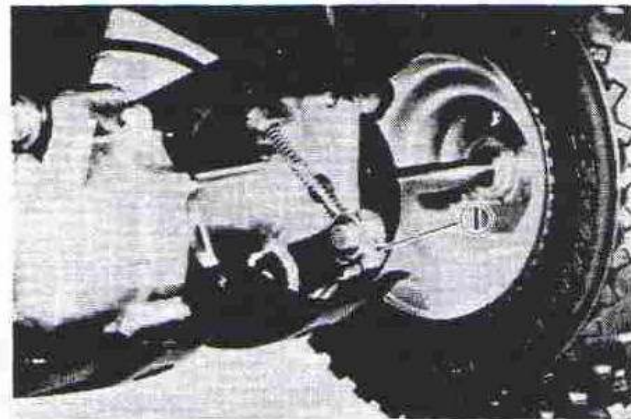

1. Adjuster

**Brake Lining Inspection**

To inspect, remove the plug from the inspection hole on the brake shoe plate and check the thickness of the lining.



- If the thickness is less than the specified value, replace the brake shoe as a set.

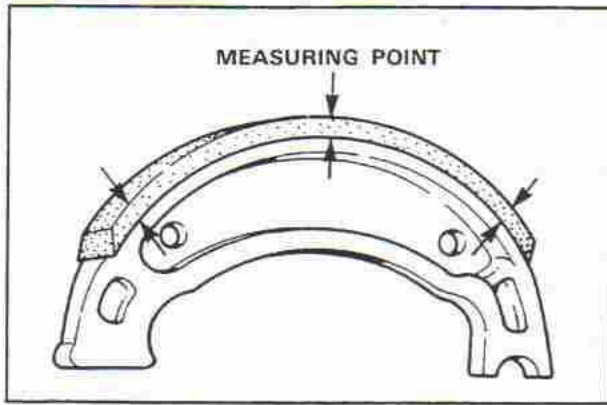

Wear Limit: 2 mm (0.08 in)

### WARNING:

Be sure to replace the inspection hole plug securely. If water enters the brake shoe area it can cause a temporary loss of braking capability which may cause loss of control and injury.

### Steering Head Adjustment

The steering assembly should be checked periodically for looseness.

- Raise the front end of the machine so that there is no weight on the front wheel.
- Grasp the bottom of the forks and gently rock the fork assembly backward and forward, checking for looseness in the steering assembly bearings.

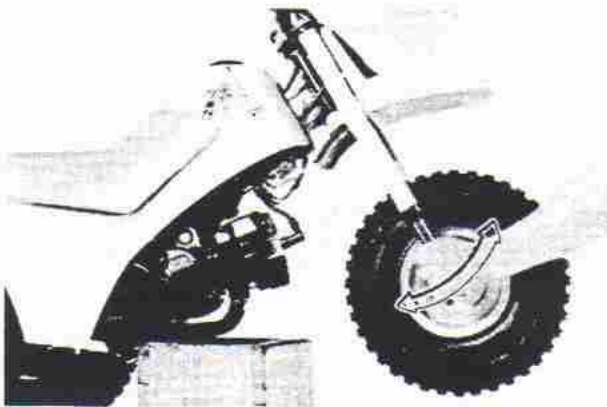

- If the steering head is loose, adjust it. Remove the handlebar protector, starter (choke) cable, and handlebars securing nuts from the steering crown.

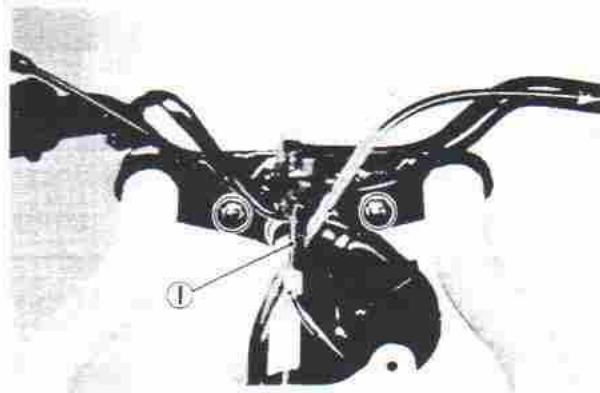

1. Choke cable

- Remove the front fork and steering stem securing bolts. Remove the steering crown.

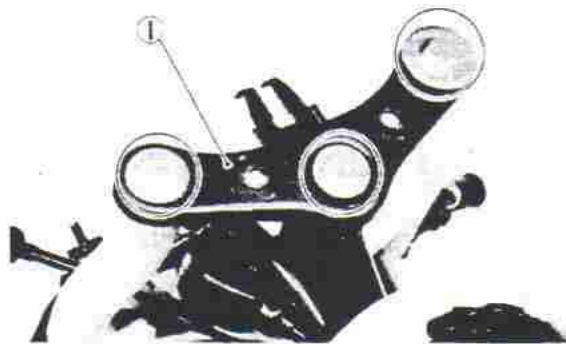

1. Steering crown

- Tighten the steering stem ring nut by hand as shown.

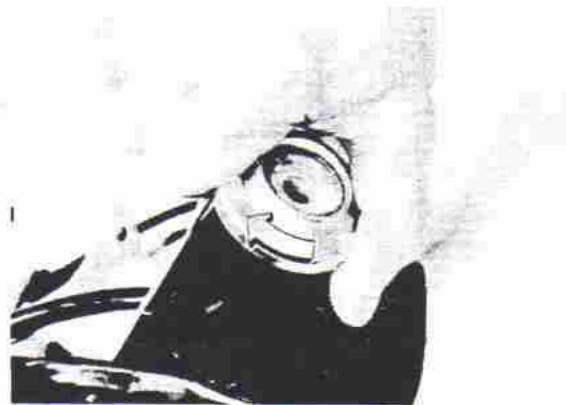

- Install the steering crown, and tighten the stem bolt, and fork bolts to specification.

### TIGHTENING TORQUE:

Steering Stem Bolt:

32.0 Nm (3.2 m·kg, 23 ft·lb)

Front Fork & Steering Crown:

32.0 Nm (3.2 m·kg, 23 ft·lb)

7. Install the handlebar onto the steering crown and tighten the nuts to specification.

**TIGHTENING TORQUE:**  
19.0 Nm (1.9 m·kg, 13 ft·lb)

8. Install the starter cable and handlebar guard.

### Wheel Bearings

If a rolling rumble is noticed and increases with increasing wheel speed (not engine or transmission speed), the wheel bearings may be worn. Check the wheel bearings for both the front and rear wheels.

### Front Wheel

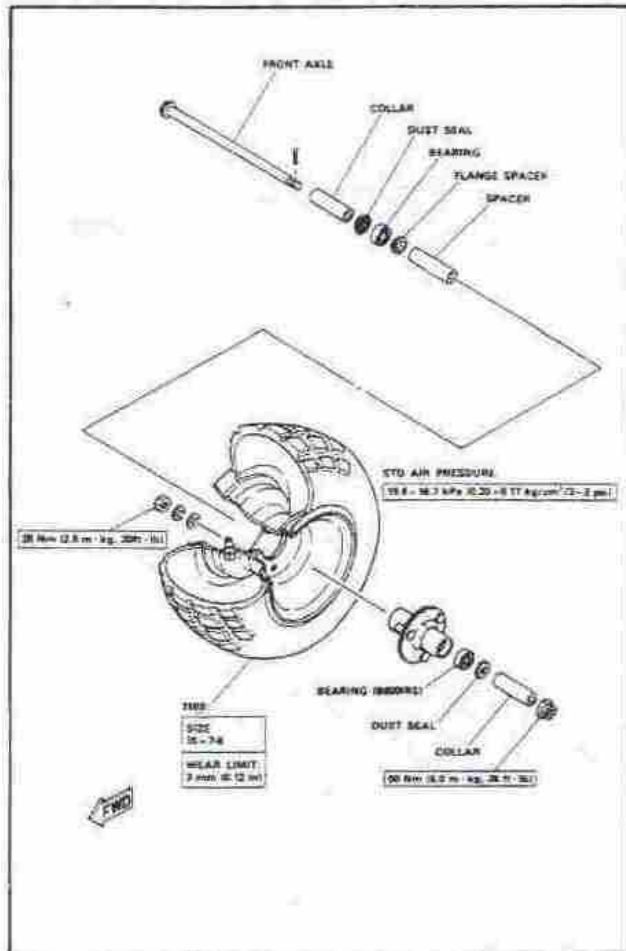

### Rear Wheel

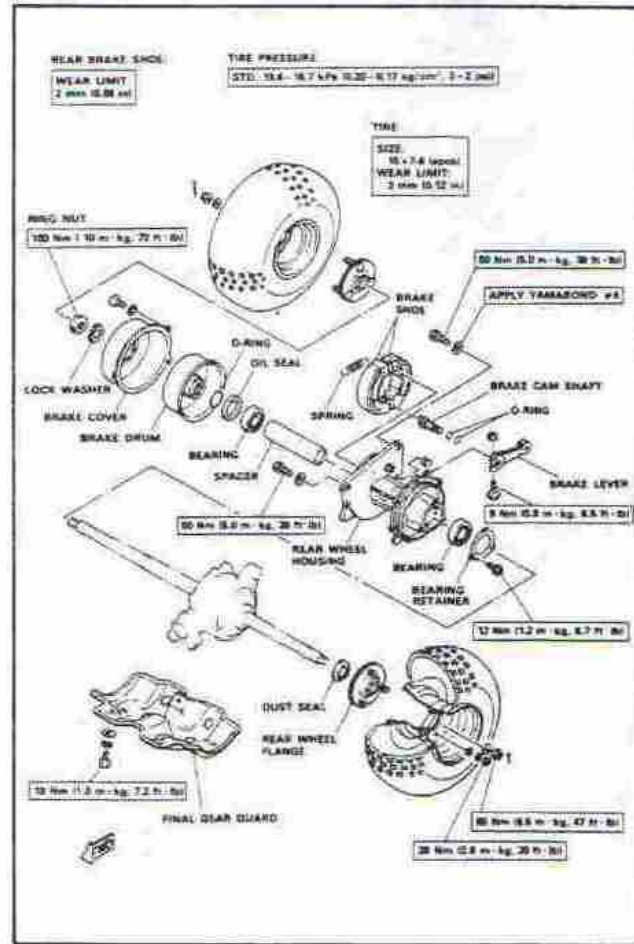

### Fuel Cock

If either fuel cock is leaking or is excessively contaminated, it should be removed from the fuel tank and inspected.

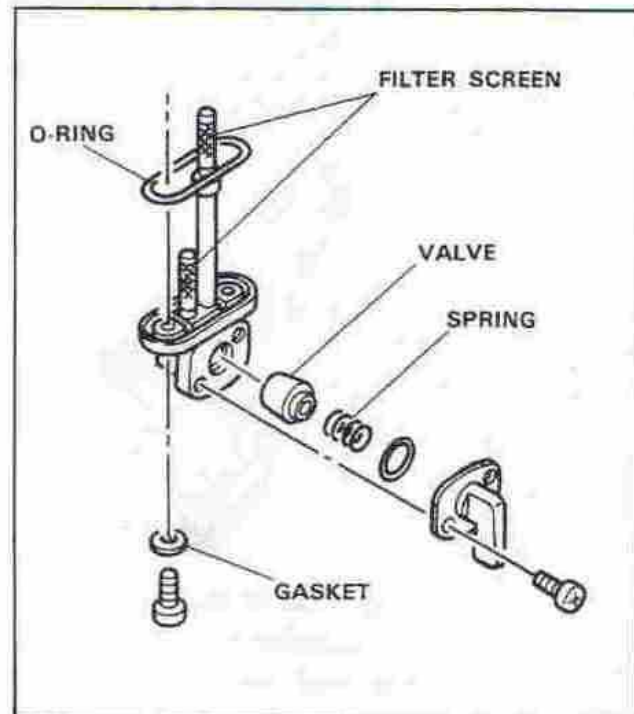

1. Remove the fuel tank and position it so that fuel will not spill when the fuel cock is removed.
2. Remove the fuel cock and inspect the filter screen. Replace the fuel cock assembly if it is seriously contaminated.
3. Inspect all components, and replace any that are damaged. If the fuel cock gasket and O-ring surfaces are scratched or corroded, the fuel cock assembly must be replaced. If there is abrasive damage to any components, the fuel tank must be drained and flushed.
4. Reassemble the fuel cock, and install it on the fuel tank.

## Tires

### WARNING:

This model is equipped with low pressure tires. Pay attention to the following points:

Recommended tire pressure:

19.6 kPa (0.2 kg/cm<sup>2</sup>, 3 psi)

Vehicle load limit: 40 kg (88 lb)

Tire size: 15×7-6

1. Excessive tire pressure (over 98.1 kPa (1.0 kg/cm<sup>2</sup>, 15 psi)) may cause tire to burst. Inflate tires very slowly. Fast inflation could cause tire to burst.
2. Too low a pressure (below 16.7 kPa (0.17 kg/cm<sup>2</sup>, 2.4 psi)) will cause the rim to dislodge from the tire.
3. Put the same pressure in both rear tires. Uneven tire pressure will severely affect the handling.
4. Set tire pressures cold.

### How to Measure Tire Pressure

Use an appropriate low-pressure tire gauge. Set tire pressures to the following specifications:

Reference Tire Pressure:

19.6 kPa (0.20 kg/cm<sup>2</sup>, 3 psi)

Minimum Tire Pressure:

16.7 kPa (0.17 kg/cm<sup>2</sup>, 2.4 psi)

### CAUTION:

Never use a tire pressure below minimum specification. The tire could separate from the wheel under severe operating conditions.

### Tire Wear Limit

When the tire groove decreases to 3 mm (0.12 in) due to wear, replace the tire.

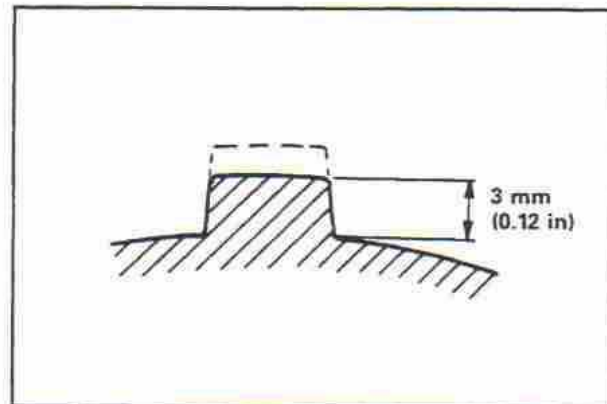

### Cable Inspection and Lubrication

1. Damage to the outer housing of the various cables may cause corrosion. Often free movement will be obstructed. An unsafe condition may result. Replace such cables as soon as possible.
2. If the inner cables do not operate smoothly, lubricate or replace them.

### Recommended Lubricant:

Yamaha Chain and Cable Lube or  
10W30 Motor Oil

# CHAPTER 3

## ENGINE OVERHAUL

<b>ENGINE REMOVAL</b> .....	3-1
Preparation for Removal .....	3-1
Muffler Assembly .....	3-1
Leads and Cables .....	3-1
Carburetor .....	3-2
Engine Removal .....	3-2
<b>ENGINE DISASSEMBLY</b> .....	3-3
Cylinder Head, Cylinder and Piston .....	3-3
Reed Valve and Autolube Pump Assembly .....	3-3
Right Crankcase (Clutch) Covers .....	3-4
Clutch Assembly and Primary Gears .....	3-4
Flywheel Magneto .....	3-5
Crankcase and Crankshaft .....	3-5
<b>INSPECTION AND REPAIR</b> .....	3-7
Cylinder Head .....	3-7
Cylinder .....	3-8
Piston and Piston Rings .....	3-8
Crankshaft and Connecting Rod .....	3-10
Autolube Pump .....	3-11
Clutch .....	3-12
Middle Gears .....	3-12
Crankcase .....	3-12
Bearings and Oil Seals .....	3-13
Recoil Starter .....	3-13
<b>ENGINE ASSEMBLY AND ADJUSTMENT</b> .....	3-16
Important Information .....	3-16
Left-Side Crankcase .....	3-17
Right-Side Crankcase .....	3-19
Flywheel Magneto .....	3-20
Primary Drive Gear and Clutch .....	3-20
Right Crankcase Cover, Carburetor Joint, and Autolube Pump .....	3-21
Piston, Cylinder, Cylinder Head, and Recoil Starter .....	3-22
Rear Wheel Drive Assembly .....	3-23
Mounting the Engine .....	3-23

# CHAPTER 3

## ENGINE OVERHAUL

### ENGINE REMOVAL

#### NOTE:

- It is not necessary to remove the engine in order to remove the cylinder, clutch and/or the flywheel magneto.
- It is necessary to remove the rear wheel drive assembly in order to remove the engine assembly.

#### Preparation for Removal

1. All dirt, mud, dust, and foreign material must be cleaned from the engine before the engine is removed and disassembled. This will help keep foreign material out of the engine oil.
2. Before engine removal and disassembly, be sure that you have the proper tools and cleaning equipment. With them you can perform a clean and efficient job.
3. During engine disassembly, clean all parts and place them in trays in their order of disassembly. This will speed up assembly and help assure that all parts are correctly reinstalled in the engine.
4. Start the engine and let it warm-up. Stop the engine and drain the transmission oil.
5. Remove the seat and body cowl assembly.

#### Muffler Assembly

1. Loosen the muffler clamp bolt, and remove the muffler securing bolts. Remove the muffler assembly.

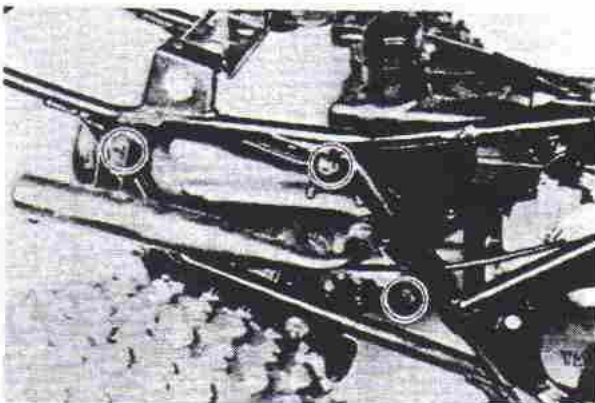

2. Remove the exhaust pipe flange bolts, and remove the exhaust pipe.

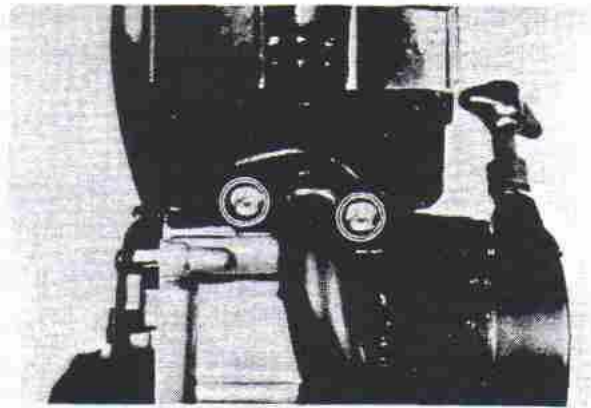

#### Leads and Cables

1. Disconnect the flywheel magneto leads and spark plug lead.
2. Loosen the brake cable adjuster on the brake lever.

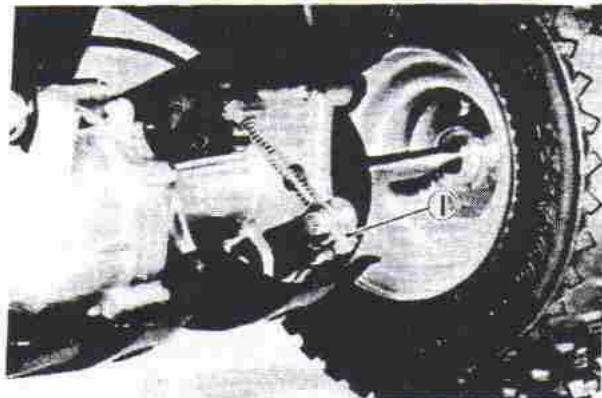

1. Adjuster

3. Disconnect the cable from the brake lever, slit holder, and cable guide.
4. Remove the Autolube pump cover, and disconnect the Autolube pump cable.
5. Disconnect the oil hose from the oil tank.

#### NOTE:

Do not leave the oil hose disconnected from the oil tank, or oil will flow out of the oil tank. It is advisable to plug the oil tank end with a proper size rubber cap.

### Carburetor

1. Turn the fuel cock to "OFF".
2. Disconnect the fuel hose from the carburetor.
3. Disconnect the oil delivery hose from the carburetor.
4. Remove the carburetor top cover securing screw, and pull out the throttle valve and starter plunger.

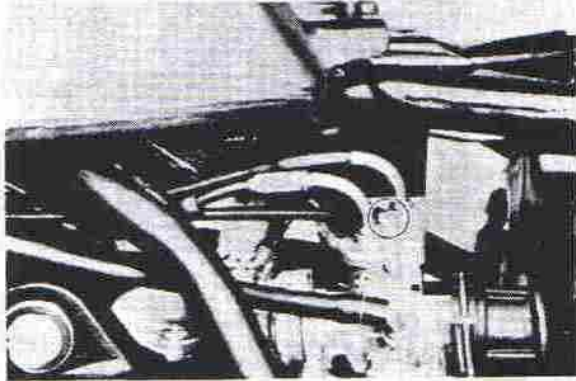

5. Remove the air-cleaner-inlet-hose-clip, and loosen the carburetor securing screw. Remove the carburetor assembly.

### Engine Removal

1. Place a suitable stand under the engine, and remove the upper and lower engine mounting bolts.

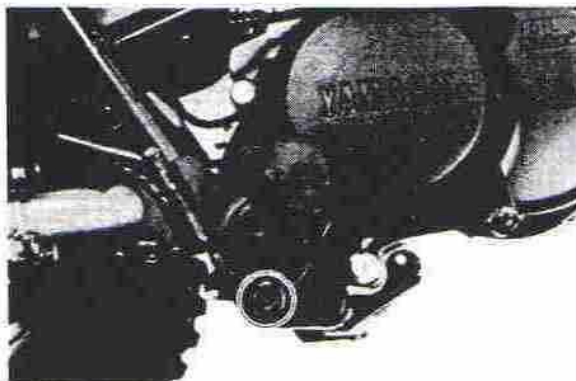
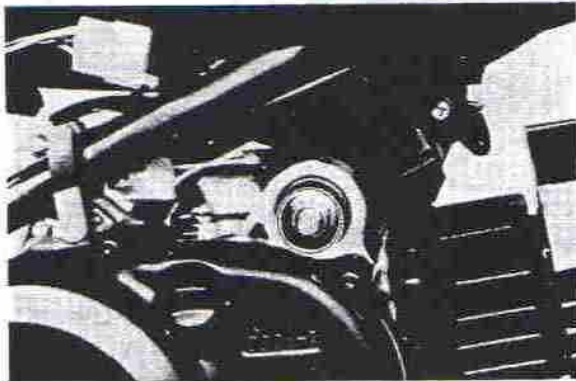

2. Remove the rear wheel hub housing and final gear housing securing bolts.

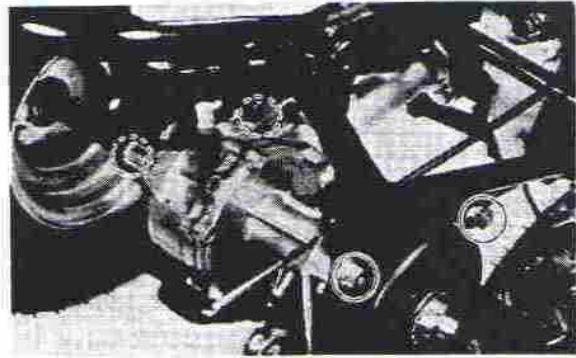

3. Pull the rear frame upward and remove the frame with the front wheel assembly.

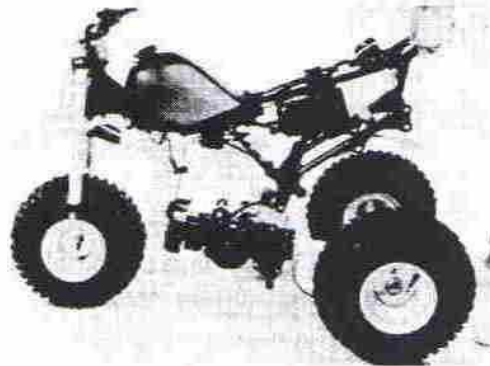

4. Remove the drive shaft housing securing bolts from the engine, and disconnect the rear wheel drive assembly from the engine.

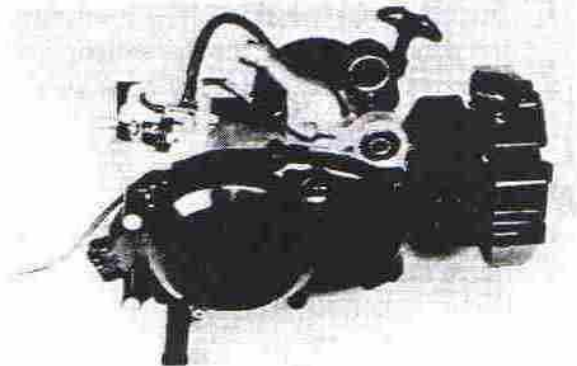

REAR WHEEL DRIVE ASSEMBLY

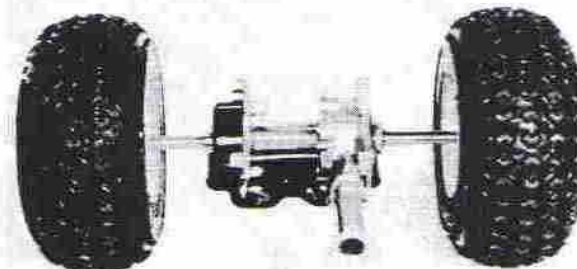

# ENGINE DISASSEMBLY

## Cylinder Head, Cylinder and Piston

1. Remove the cylinder head securing nuts. Each nut must be loose before any one is removed.

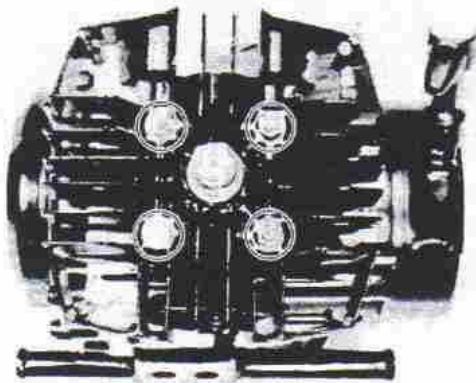

2. Remove the cylinder head, gaskets, and cylinder.
3. Remove the piston pin clip from the piston.

### NOTE:

Before removing the piston pin clip, cover the crankcase with a clean rag so you will not accidentally drop the clip into the crankcase.

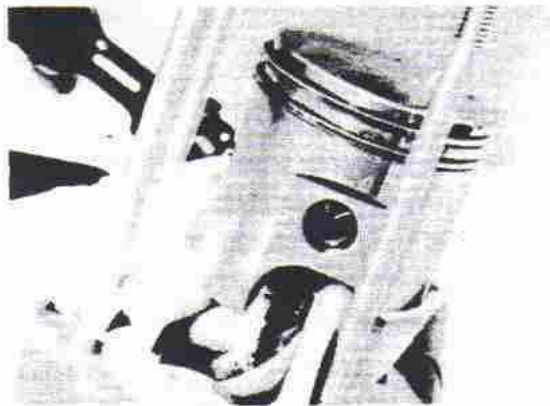

4. Push the piston pin from the opposite side, then pull out.

### CAUTION:

Do not use a hammer to drive the piston pin out.

### NOTE:

Before removing the piston pin, deburr the clip groove and pin hole area. If after the piston pin groove is deburred, the piston pin is still difficult to remove, use the piston pin puller.

## Reed Valve and Autolube Pump Assembly

1. Remove the carburetor joint securing bolts. Remove the joint and valve assembly from the crankcase.

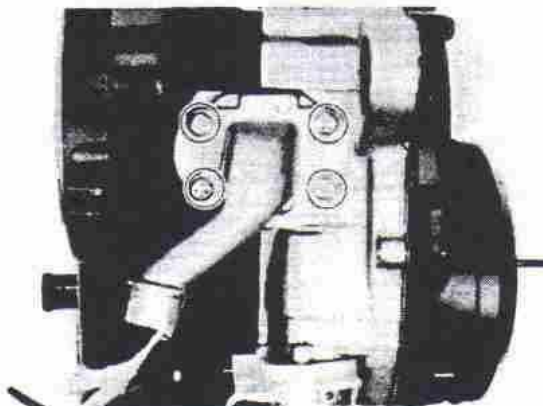

2. Remove the two Autolube pump securing bolts and remove the Autolube pump assembly and pump cover.

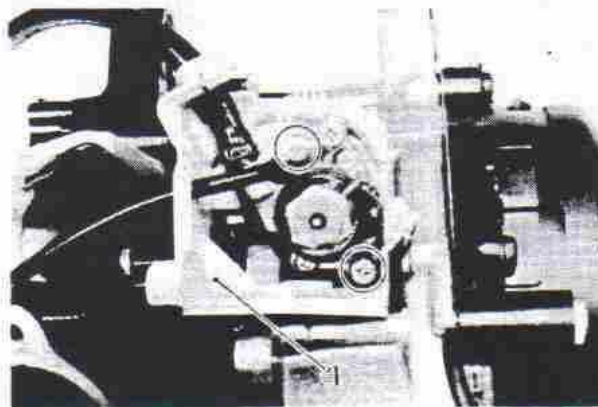

1. Cover



### Right Crankcase (Clutch) Covers

1. Remove the clutch cover securing bolts and drain bolt. Remove the covers, gasket, two dowel pins, and crankcase breather hose.

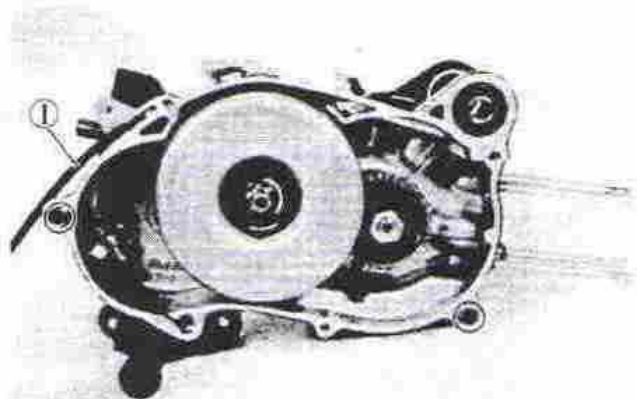
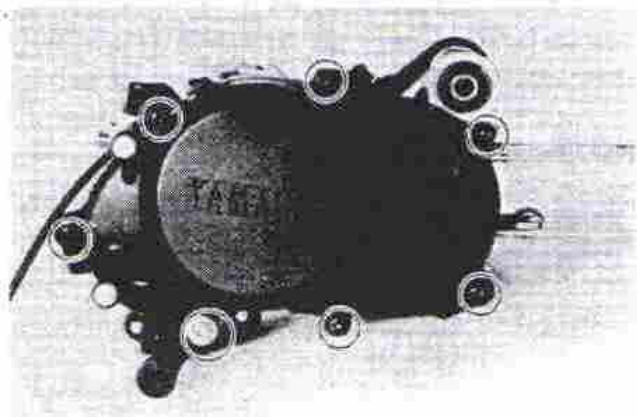

1. Crankcase breather hose

### Clutch Assembly and Primary Gears

1. Remove the circlip and clutch housing.

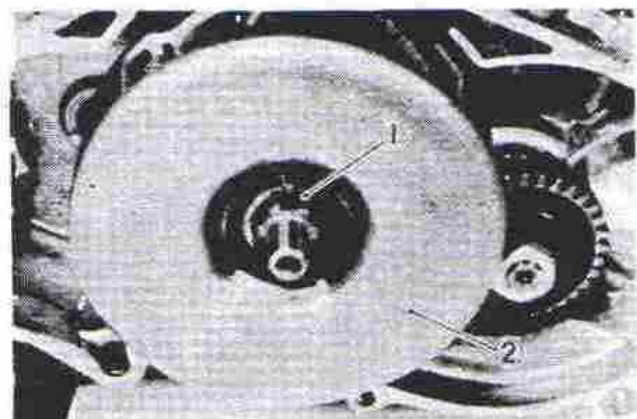

1. Circlip 2. Clutch housing

2. Remove the clutch shoe/driven gear assembly.

### NOTE:

There is a washer under the primary driven gear which may stick to the driven gear when the clutch shoe/driven gear assembly is removed.

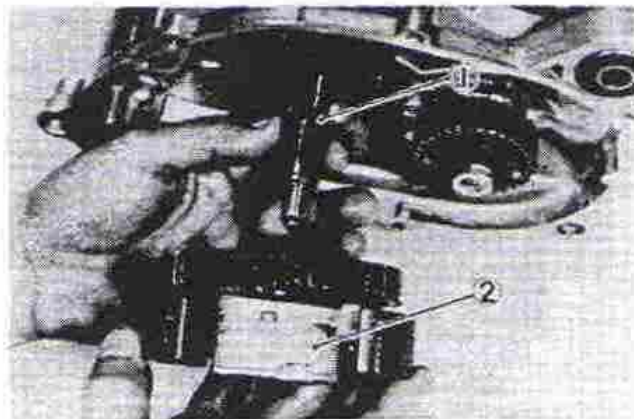

1. Washer 2. Clutch shoe/driven gear assembly

3. Remove the Autolube-pump-drive-gear retaining clip and drive gear.

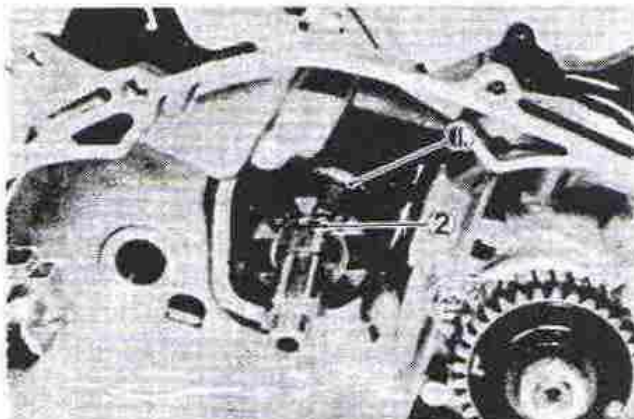

1. Drive gear 2. Circlip

4. Remove the recoil starter assembly from the left-side crankcase.
5. Hold the flywheel magneto with the universal rotor holder and loosen the primary drive gear securing nut.

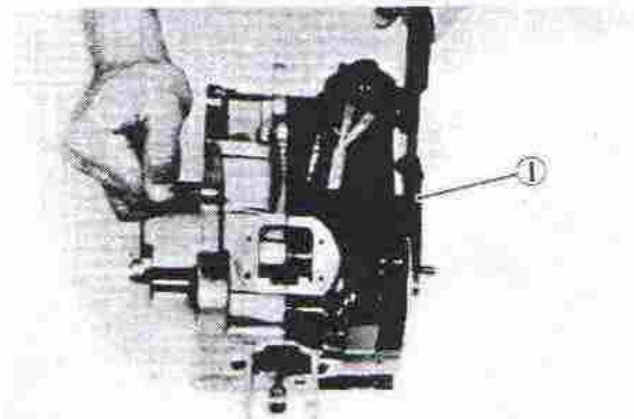

1. Universal rotor holder

- Remove the nut, washer, drive gear, key, and thrust washer from the crankshaft.

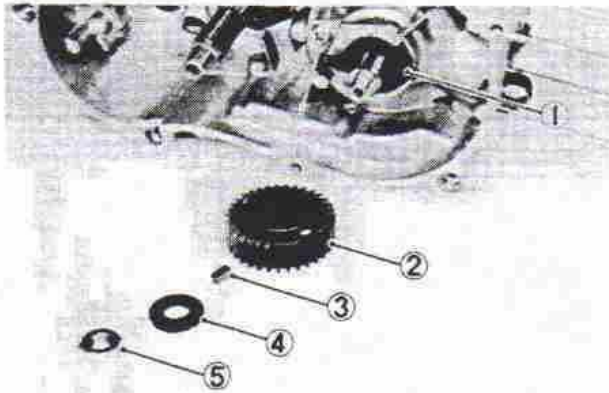

- |                       |           |
|-----------------------|-----------|
| 1. Thrust washer      | 4. Washer |
| 2. Primary drive gear | 5. Nut    |
| 3. Key                |           |

### Flywheel Magneto

- Hold the flywheel magneto with the universal rotor holder, and remove the recoil starter pulley securing bolts and pulley.

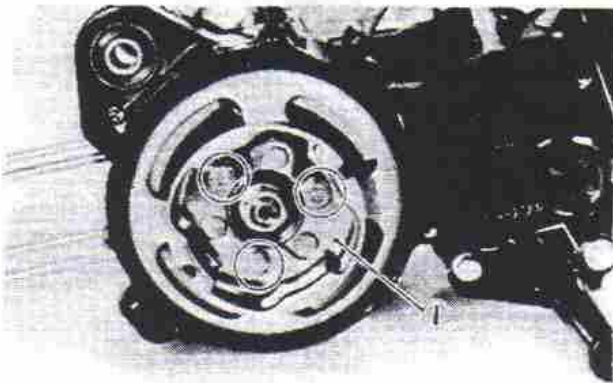

- Recoil starter pulley

- Hold the flywheel magneto with the universal rotor holder, and remove the flywheel magneto securing bolt.

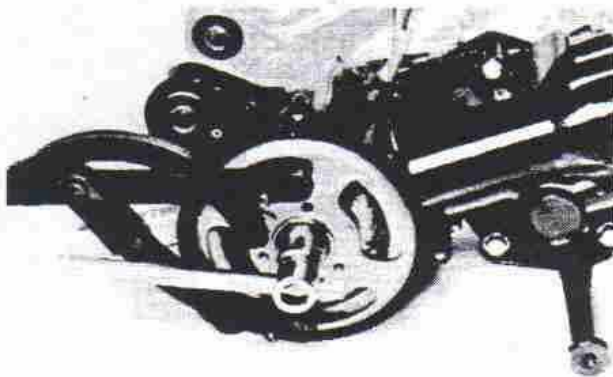

- Remove the flywheel magneto by using the flywheel puller. Remove the woodruff key from the crankshaft.

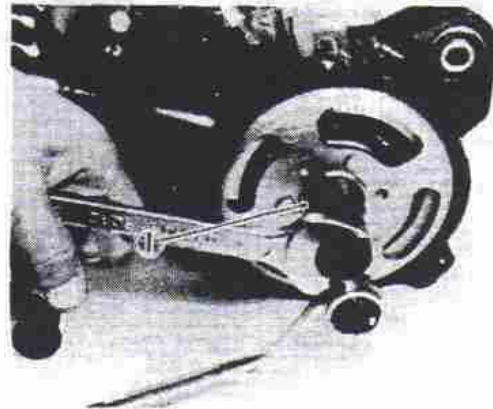

- Flywheel puller

- Remove the C.D.I. magneto base from the crankcase.

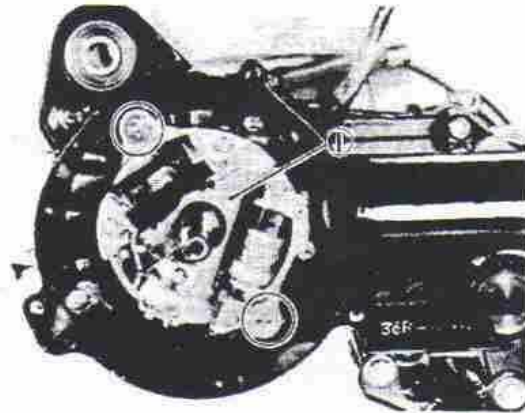

- C.D.I. magneto base

### Crankcase and Crankshaft

- Remove the oil seal retainer and collar.

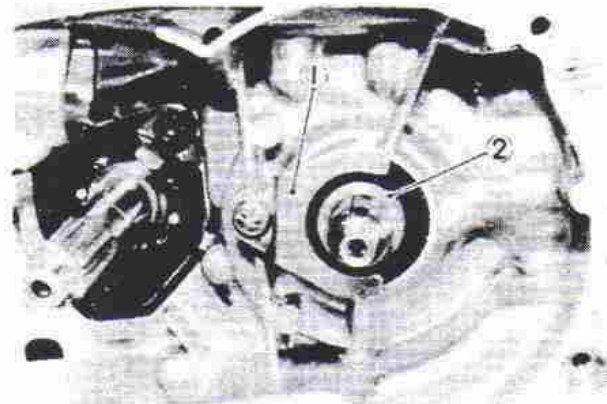

- Oil seal retainer
- Collar

- Remove the crankcase securing bolts and lower-engine-mounting bracket.

**NOTE:**

Working in a crisscross pattern, loosen all bolts 1/4 turn each. Remove them after all are loosened.

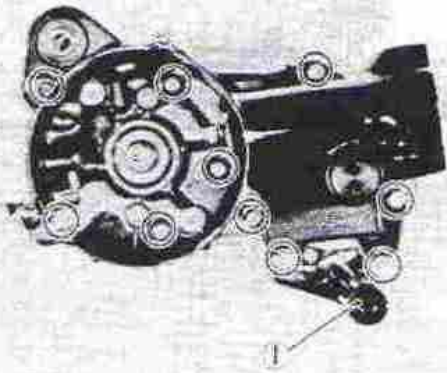

1. Bracket

3. Remove the left-side crankcase from the right-side crankcase, and remove the two dowels.
4. Place the 3-way universal puller on the crankshaft, and remove the crankshaft from the left-side crankcase.



1. Universal puller

The following steps are necessary only if you must service the middle gears or replace the crankcase.

5. Remove the main axle bearing retainer securing bolts. Remove the bearing retainer and gear stopper plate.

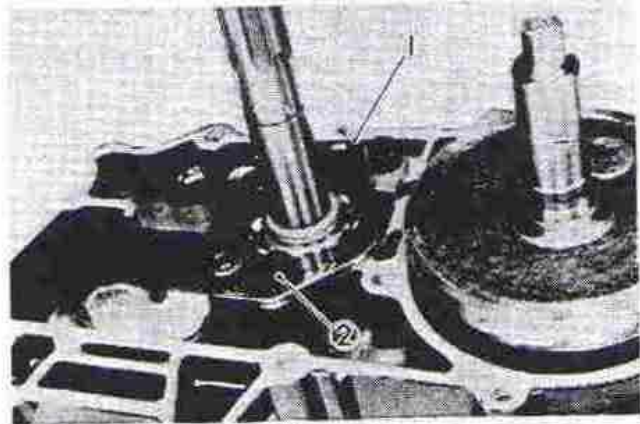

1. Stopper plate 2. Bearing retainer

6. Pull out the main axle. Don't forget to remove the pinion shim from inside of the case.

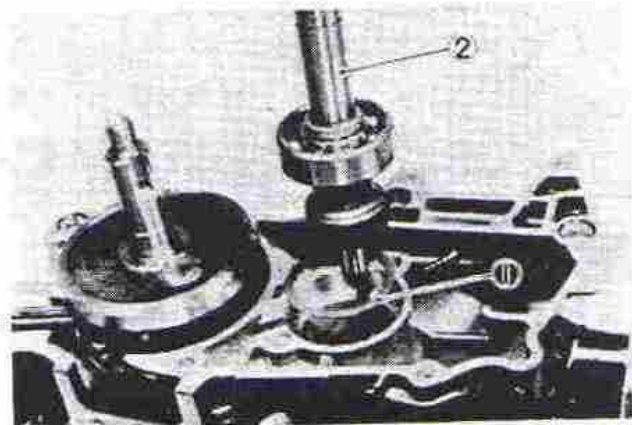

1. Shim 2. Main axle

7. Remove the middle-drive-shaft oil seal by carefully prying out; use the screw driver and hammer.

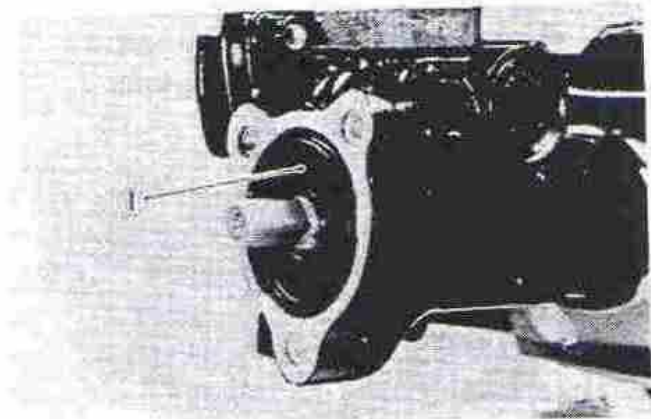

1. Oil seal

8. Remove the middle-drive-shaft-bearing retainer nut with the Hexagon Wrench (25 mm).

**CAUTION:**

The middle-drive-shaft-bearing-retainer nut has left-hand threads. Turn the retainer nut clockwise to loosen it.

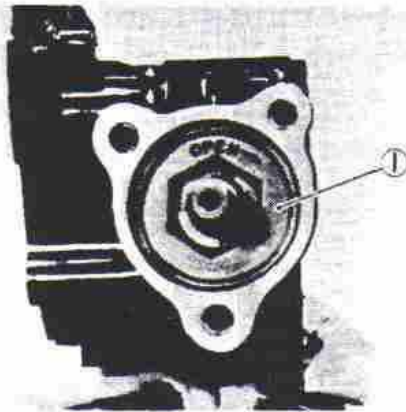

1. Bearing retainer nut

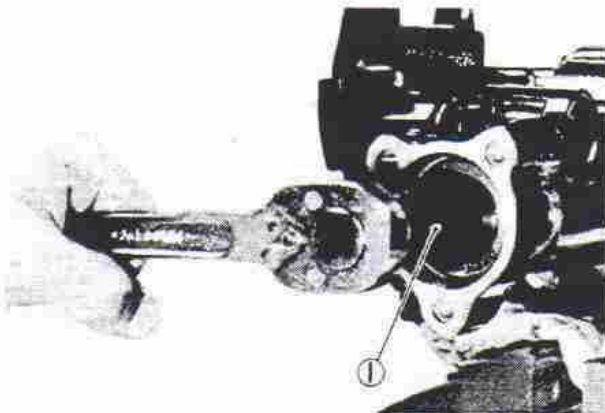

1. Hexagon Wrench (25 mm)

9. Remove the middle drive shaft assembly with the shim(s) from the crankcase.

## INSPECTION AND REPAIR

### Cylinder Head

1. Check the cylinder head warpage with a straightedge as shown.  
The warpage should not exceed the specified limit; if necessary, resurface the cylinder head.

Cylinder Head Warpage:  
Less than 0.03 mm (0.0012 in)

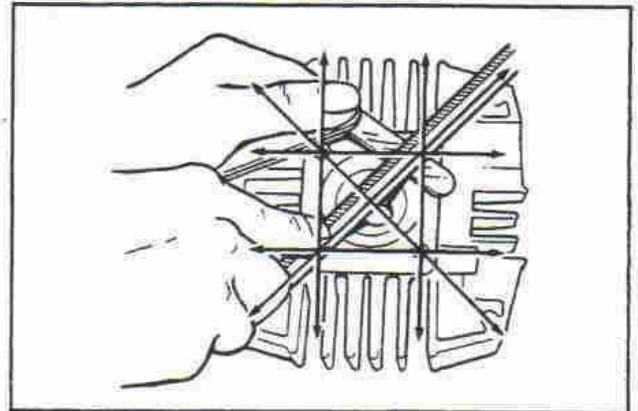

2. Place 400 – 600 grit wet sandpaper on surface plate and re-surface head using a figure-eight sanding pattern. Rotate head several times to avoid removing too much material from one side.
3. Using a rounded scraper, remove carbon deposits from combustion chamber. Take care to avoid damaging spark plug threads. Do not use a sharp instrument. Avoid scratching the combustion chamber surface.

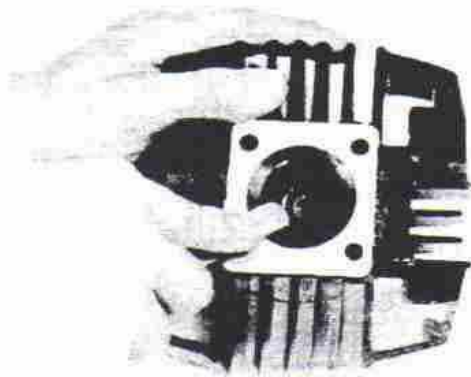

## Cylinder

1. Visually check the cylinder walls for scratches. If vertical scratches are evident, the cylinder should be replaced.
2. Measure cylinder wall wear in the manner as shown. If wear is excessive, compression pressure will decrease, and engine trouble will occur. Rebore the cylinder wall, and replace the piston and piston rings.

Cylinder wear should be measured at three depths by placing the measuring instrument at a right angle to the crankshaft. (See the illustration.)

If the cylinder wall is worn beyond the wear limit, it should be rebored.

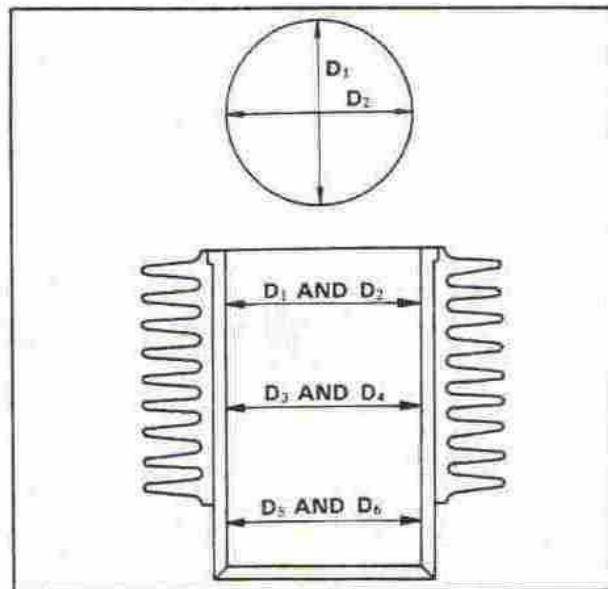
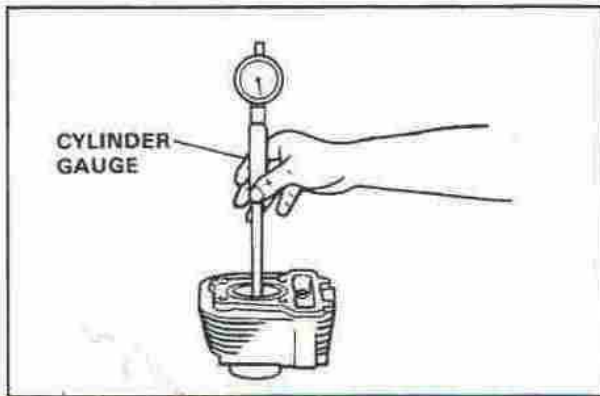

	Standard	Wear Limit
Cylinder Bore	43.933 ~ 44.012 mm (1.7320 ~ 1.7328 in)	44.1 mm (1.7362 in)
Cylinder Taper	—	0.05 mm (0.002 in)

## Piston and Piston Rings

### Piston

1. Visually check the piston for scratches. If vertical scratches are evident, the piston should be replaced.
2. Using the micrometer, measure the outside diameter of the piston at the piston skirt. Measurement should be made at a point 5.0 mm (0.2 in) above the bottom edge of the piston by placing the micrometer parallel to and at right angles to the piston pin. Replace the piston if wear exceeds the limit.

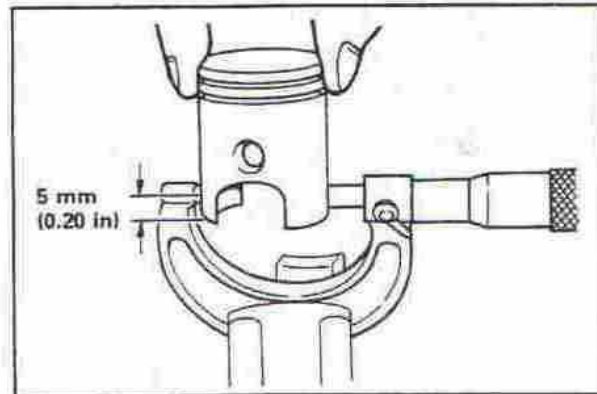

Standard	43.952 ~ 43.972 mm (1.7304 ~ 1.7312 in)
Oversize 1	44.25 mm (1.74 in)
Oversize 2	44.50 mm (1.75 in)

### Piston Clearance:

0.040 ~ 0.048 mm (0.0016 ~ 0.0019 in)

3. Piston ring/ring groove fit must have correct clearance. If the piston and ring have already been used in the engine, the ring must be removed, the ring groove cleaned of carbon, then the ring should be reinstalled. Use a feeler gauge to measure the gap between the ring and the land. Replace the piston if wear exceeds the limit.

Side Clearance	Top	0.03 ~ 0.05 mm (0.0012 ~ 0.0020 in)
	2nd	0.03 ~ 0.05 mm (0.0012 ~ 0.0020 in)
	Oil	—

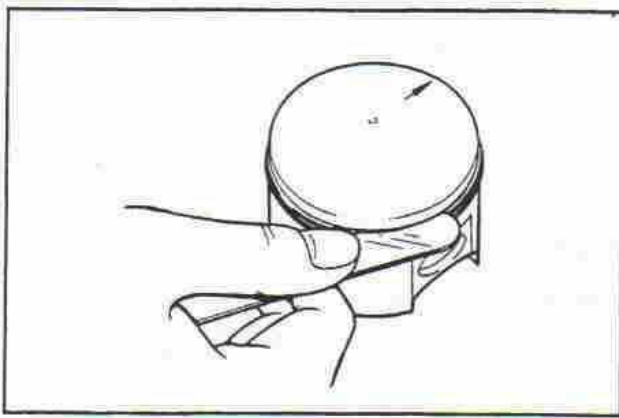

### Piston Ring

The oversize top and second ring sizes are stamped on top of the ring.

Oversize 1	0.20 mm (0.0079 in)
Oversize 2	0.50 mm (0.0197 in)

1. Measure the end gap of each piston ring. Insert a ring into the cylinder, and push it approximately 20 mm (0.8 in) into the cylinder. Push the ring with the piston crown so the ring will be at a right angle to the cylinder bore.
2. Measure the ring end gap with a feeler gauge. If the end gap exceeds tolerance, replace the whole set of rings.

### NOTE:

You cannot measure the end gap on the expander spacer of the oil control ring. If the oil-control-ring rails show excessive gap, replace all three rings.

	Standard	Limit
Top Ring	0.15 ~ 0.30 mm (0.0059 ~ 0.0118 in)	0.70 mm (0.0276 in)
2nd Ring	0.15 ~ 0.30 mm (0.0059 ~ 0.0118 in)	0.70 mm (0.0276 in)

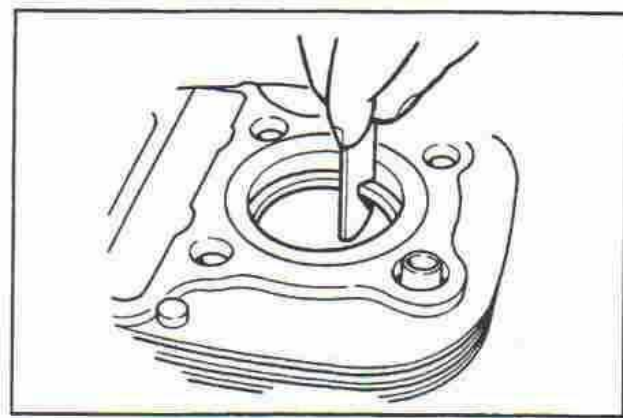

### Piston Pin

1. Lightly oil the piston pin, and install it in the small end of the connecting rod.
2. Check the free play. There should be no noticeable vertical play. If any free play exists, check the connecting rod for wear. Replace the pin and connecting rod as required.
3. Insert the piston pin in the piston, and check the free play. There should be no noticeable free play when the pin is in place in the piston. If the piston pin is loose, replace the pin and/or the piston as required.

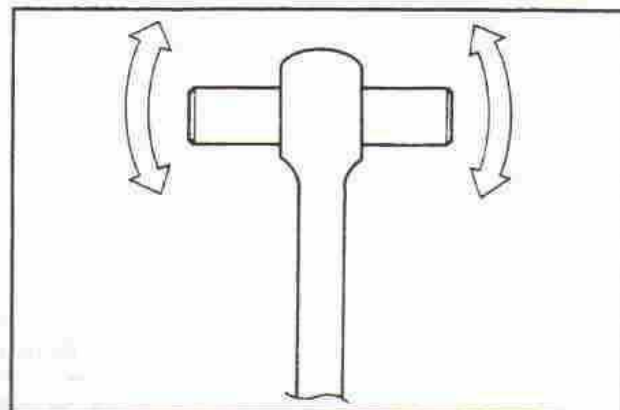
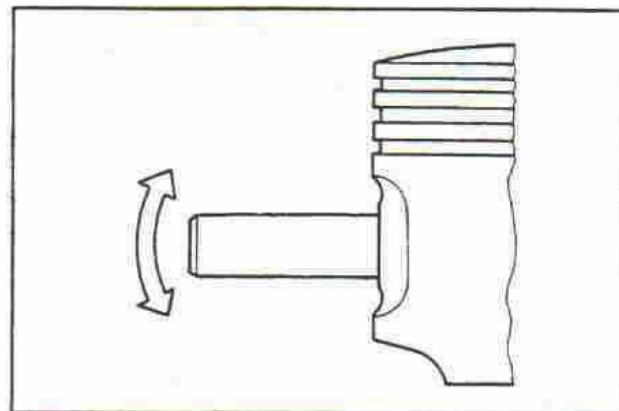

## Crankshaft and Connecting Rod Crankshaft Bearing

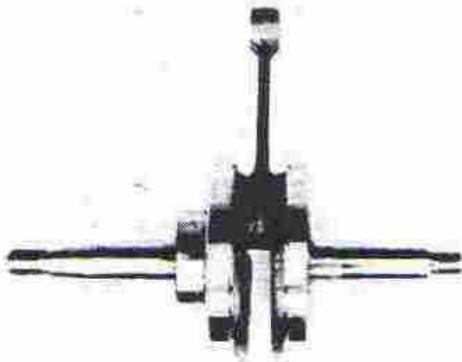

1. Bearings should be cleaned, dried, and the races visually checked for pits, rust spots, or chatter marks where the balls have dragged. If any of these conditions exist, the bearings should be replaced.

### NOTE:

Lubricate the bearings immediately after examining them to prevent rust.

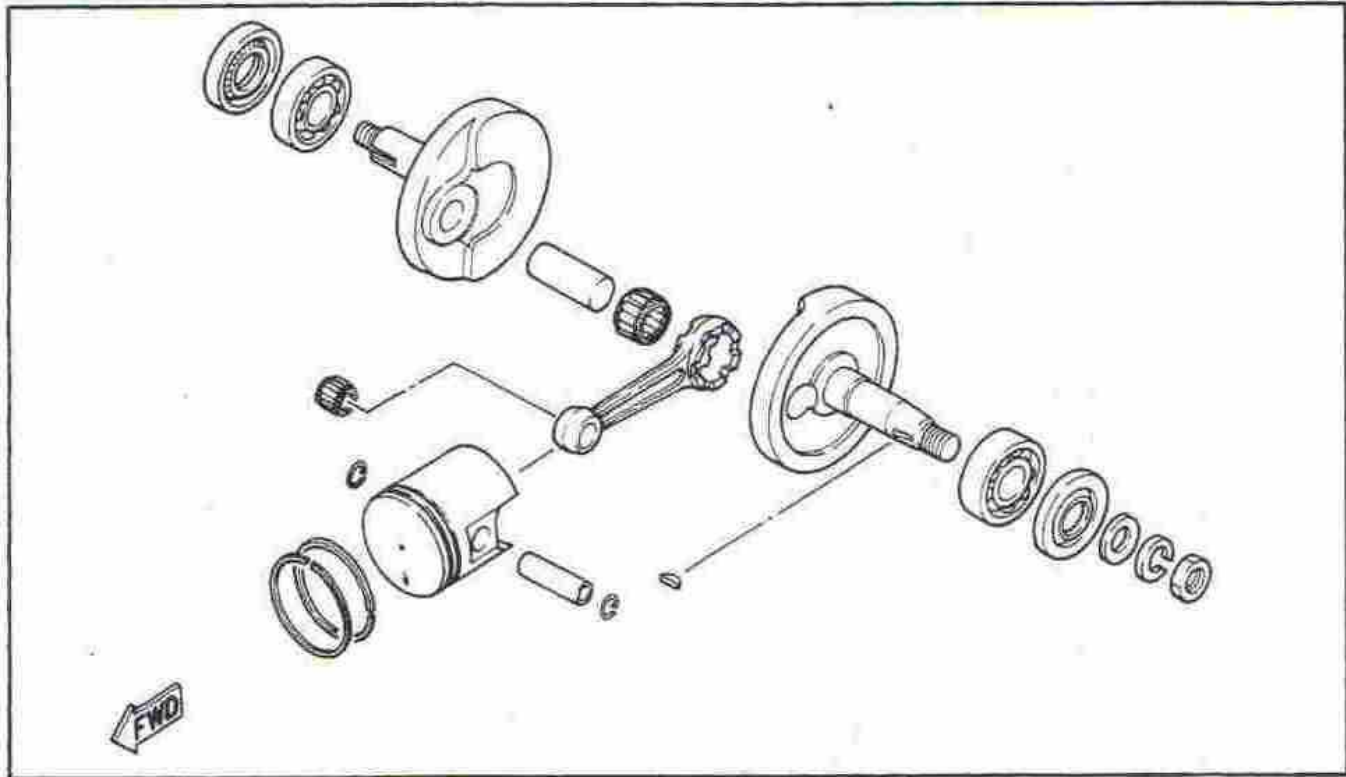

### 1. Check crankshaft components per chart.

Check connecting-rod axial play at small end (to determine the amount of wear or crank pin and bearing at big end).	Small end play should not exceed 2 mm (0.079 in).	If small end play exceeds 2 mm (0.079 in), replace left crankshaft, connecting rod assembly, buffer boss, and woodruff key. Check right crankshaft bearing. If damaged, replace bearing. Play after reassembly should be within 0.4–0.8 mm (0.0157–0.0315).
Check the connecting rod side clearance at big end.	Move the connecting rod to one side and insert a feeler gauge. Big end axial play should be within 0.35–0.55 mm (0.0138–0.0217 in).	If excessive axial play is present, 0.6 mm (0.0236 in) or more, disassemble the crankshaft and replace same parts on above.
Check crankshaft assembly runout. (Misalignment of crankshaft parts.)	Dial gauge readings should be within 0.03 mm (0.0012 in).	Correct any misalignment by tapping the flywheel with a brass hammer and by using a wedge.

## 2. Crankshaft specifications

Unit: mm (in)

Runout	Flywheel Width	Rod Clearance			
		Axial "B"		Side "C"	
Max	"A"	New	Max.	Min.	Max.
0.03 (0.0012)	37.90 ~ 37.95 (1.4921 ~ 1.4941)	0.4 ~ 0.8 (0.0157 ~ 0.0315)	2.0 (0.0787)	— (—)	0.03 (0.0012)

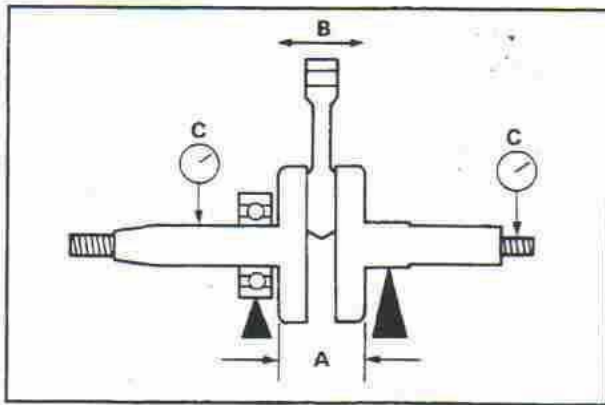

### Autolube Pump

#### 1. Troubleshooting and repair

a. Wear or an internal malfunction may cause pump output to vary from the factory setting. This situation is, however, extremely rare. If output is suspect, check the following:

- 1) Obstructions in delivery line to pump or from pump to carburetor.
- 2) Worn or damaged pump body seal or crankcase cover seal.
- 3) Improperly installed or routed oil delivery line(s).
- 4) Loose fitting(s) allowing air entry to pump and/or engine.
- 5) Drive and driven gears are damaged.

b. If all inspection shows no obvious problems and output is still suspect, connect the delivery line from the pump to a graduated container (cc). Keep the delivery line short. Remove spark plug. Open throttle to full open position. Operate kick starter continuously and count the oil pump plunger strokes. If output is not to specification, replace pump assembly.

	Minimum Throttle	Maximum Throttle
Pump Output for 200 Strokes (100 Cycles)	0.19 ~ 0.24 cc (0.006 ~ 0.008 oz)	0.91 ~ 1.06 cc (0.031 ~ 0.036 oz)

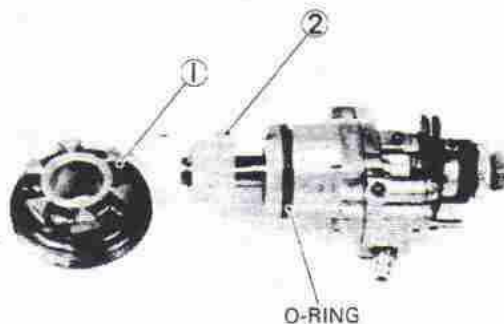

1. Drive gear 2. Driven gear



## Clutch

1. Check the clutch housing and clutch shoe assembly for heat damage.

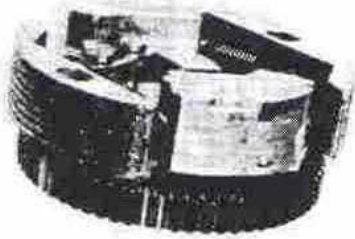

2. Replace clutch shoe assembly if any is faulty or beyond wear limit.

Clutch Shoe Wear Limit:  
0.7 mm (0.03 in)

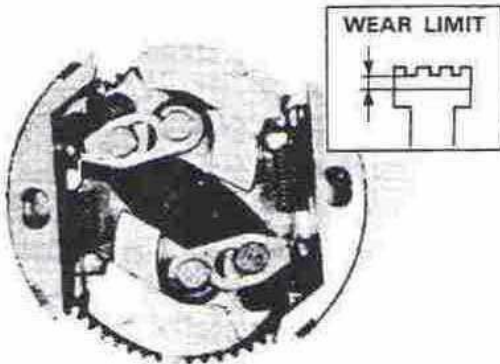

3. Check the primary drive and driven gears for obvious signs of wear or damage. Replace the gears as required.

## Middle Gears

1. Carefully inspect each gear. Look for signs of obvious heat damage (blue discoloration).
2. Check the gear teeth for signs of pitting, galling, or other extreme wear. Replace as required.

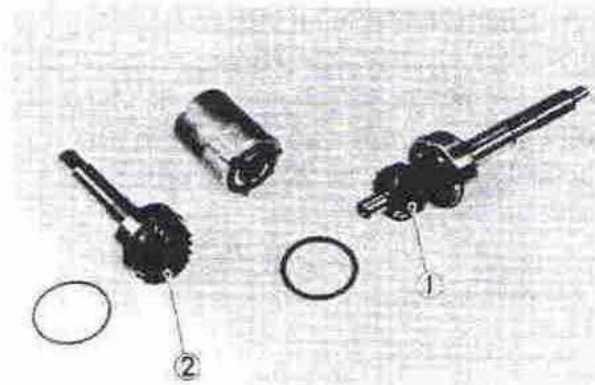

1. Middle drive gear 2. Middle driven gear

## Crankcase

1. Thoroughly wash the case halves in a mild solvent.
2. Clean all gasket mating surfaces and crankcase mating surfaces thoroughly.
3. Visually inspect the case halves for any cracks or their damage.
4. Check all fittings not previously removed for signs of looseness or damage.
5. Check oil delivery passages for signs of blockage.

### LEFT CRANKCASE

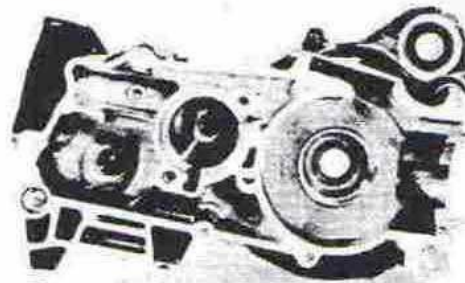

### RIGHT CRANKCASE

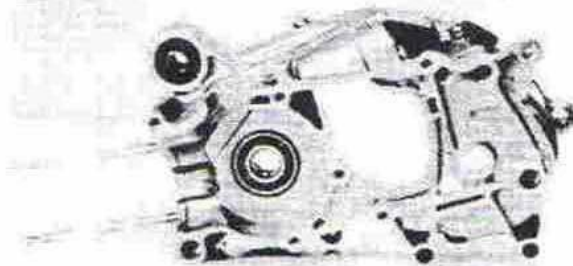

## Bearings and Oil Seals

### Oil Seals

1. Check the oil seal lips for damage and wear. Replace as required.
2. Pry oil seal(s) out of place with a screwdriver.  
Replace all oil seals when overhauling the engine.

### NOTE:

Place a piece of wood under the screwdriver to prevent damage to the case.

### Bearing

1. After cleaning and lubricating the bearings, rotate the inner race with a finger. If rough spots are noticed, replace the bearing.

2. If bearings have not been removed, oil them thoroughly immediately after washing and drying. Rotate the bearing, and check for roughness indicating damaged races or balls.
3. If bearings have been removed, check their seats for signs of damage (such as the bearing spinning in the seat, etc.).
4. Drive out the bearing(s) from each crankcase. Use the appropriate special tool.

### NOTE:

Bearing(s) are most easily removed or installed if the cases are first heated to approximately  $95^{\circ} \sim 125^{\circ}\text{C}$  ( $205^{\circ} \sim 257^{\circ}\text{F}$ ). Bring the case up to proper temperature slowly. Use an oven.

## Recoil Starter

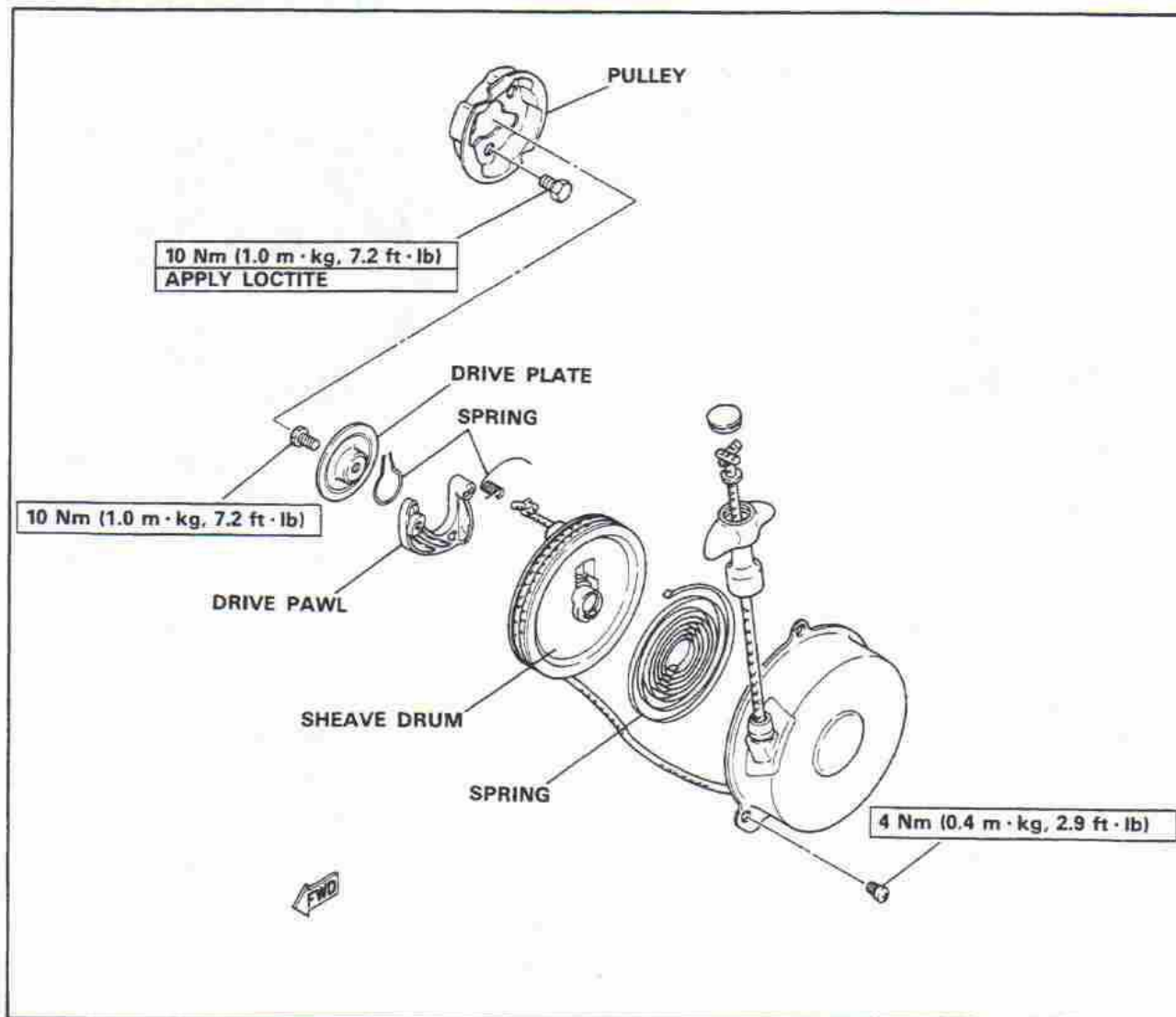

## Disassembly

1. Pull the starter knob about 400 mm (15.7 in) from the starter case and hold the sheave drum with the thumb.
2. Fit the rope into the indent in the sheave drum. Then reduce the thumb force to allow the sheave drum to wind itself back gradually.

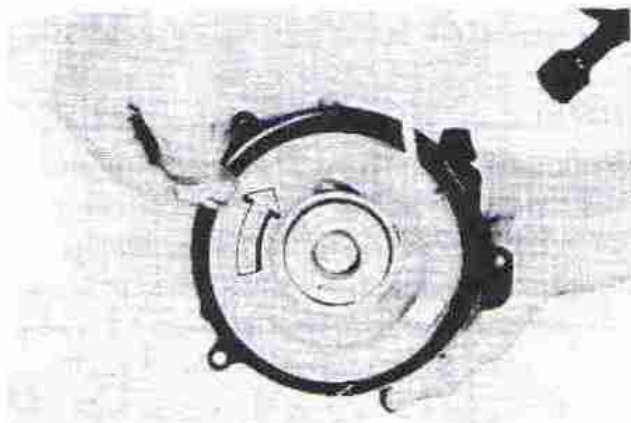

3. Remove the starter handle as a following manner:
  - a. Remove the handle cap.
  - b. Pull out the rope from the handle and unknot the rope end.
  - c. Remove the starter handle.

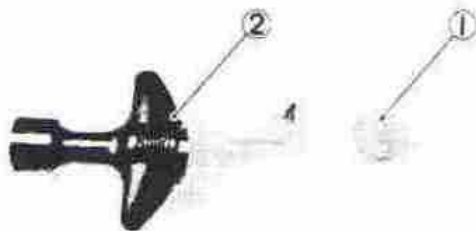

1. Handle cap 2. Starter handle

4. Remove the drive housing securing nut. Remove the drive housing, drive pawl, and drive pawl spring in that order, then slowly remove the sheave drum from the starter case.

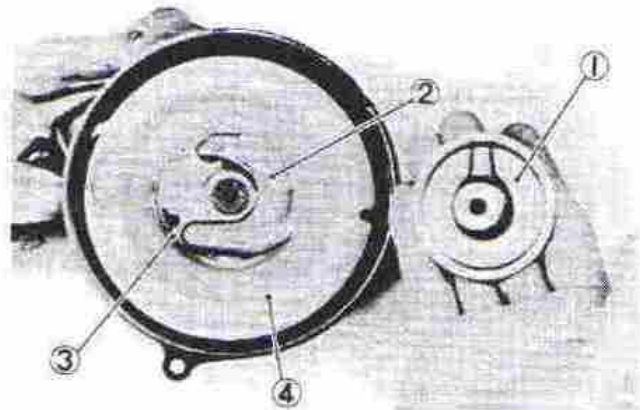

1. Drive housing 2. Drive pawl  
3. Drive pawl spring 4. Sheave drum

5. Carefully remove the starter spring from the case.

## NOTE:

Note the order of installation on the starter spring for reassembly.

## Assembly

1. Install the starter spring in the starter case.



## NOTE:

- It is necessary to wind the spring to a small size before installing it in the starter case.
- Be careful not to install the spring in the wrong way.
- Hook the loop on the outer end of the spring onto the spring hook in the starter case. Then thoroughly grease the spring.

2. Insert the rope end to the hole in the sheave drum and knot on the rope end. Wind the rope around the sheave drum in the direction of the arrow and hook the rope into the indent in the sheave drum periphery 400 mm (15.7 in) from the end of the rope.

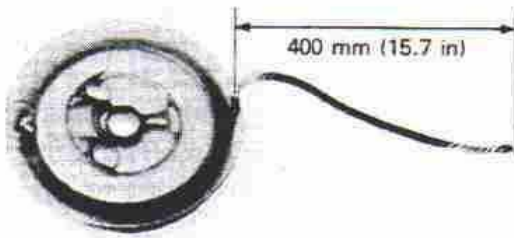

3. Insert the rope end into the hole in the starter case. Fit the free end through the starter handle, and knot the rope. Install the handle cap onto the handle.
4. Install the sheave drum into the starter case. Be sure the inner hook in the spring engages the cutout in the sheave drum. When first placed in the case, the sheave drum will be resting on the spring. Rotate the sheave drum until it drops slightly, then rotate it clockwise until you feel the spring tension.

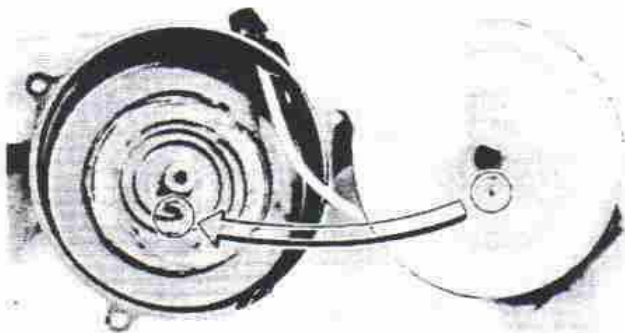

5. Install the drive-pawl spring and the drive pawl as follows: See the photograph.
  - a. The longer end of the drive spring should be inserted into the hole in the sheave drum.
  - b. Carefully install the drive pawl onto the spring so that the spring end fits a notch in the drive pawl.

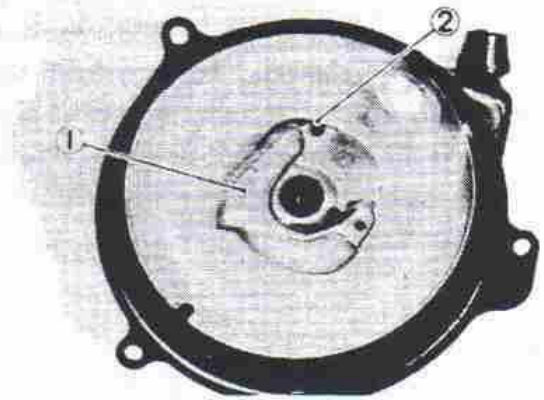

1. Drive pawl 2. Drive pawl spring

6. Install the spring-clip onto the drive housing as shown in the photograph. Apply LOCTITE® to thread of the drive housing securing nut and tighten the drive housing securing nut.

TIGHTENING TORQUE:  
10 Nm (1.0 m · kg, 7.2 ft · lb)

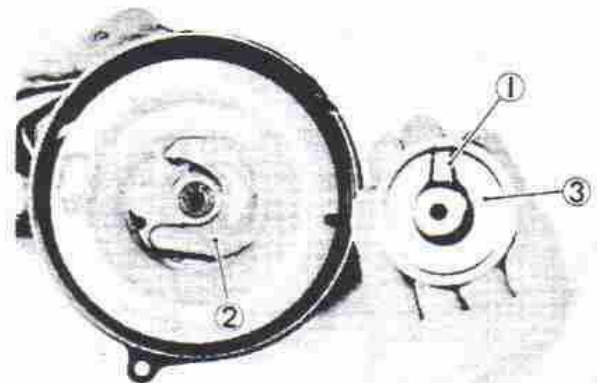

1. Spring-clip 2. Drive pawl 3. Drive housing

7. Rotate the drum four turns counterclockwise to preload the spring.

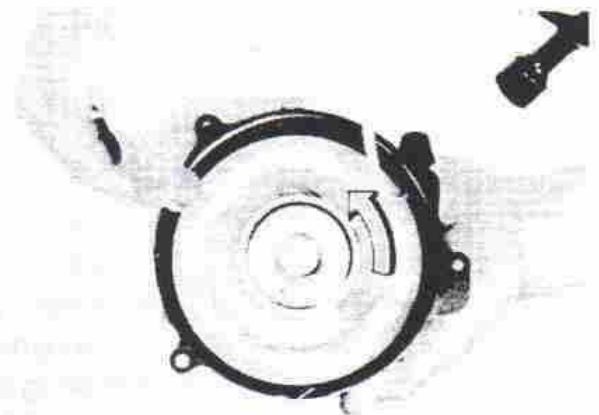

8. Check the movement of the starter. The sheave drum should rotate clockwise and the drive pawl should emerge from the sheave drum when the starter rope is pulled. If the starter does not operate correctly, disassemble the starter and reassemble it correctly.

## ENGINE ASSEMBLY AND ADJUSTMENT

### Important Information

#### Gaskets and Seals

1. All gaskets and seals should be replaced when an engine is overhauled. All gasket surfaces and oil seal lips must be cleaned.
2. Properly oil all mating parts and bearings during reassembly.

#### Circlips

1. All circlips should be inspected carefully before reassembly. Always replace piston pin clips after one use. Replace distorted circlips.

When installing a circlip, make sure that the sharp edged corner is positioned away from the thrust it receives. See the sectional view below.

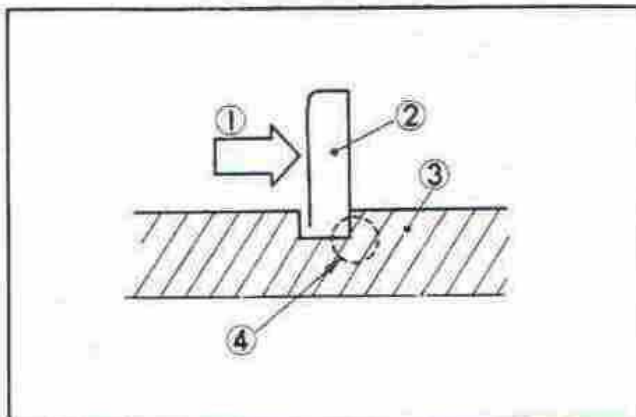

- |                 |                       |
|-----------------|-----------------------|
| 1. Thrust force | 3. Shaft              |
| 2. Circlip      | 4. Sharp edged corner |

#### Lock Washers/Plates and Cotter Pins

1. All lock washers/plates and cotter pins must be replaced when they are removed. Lock tab(s) should be bent along the bolt or nut flat(s) after the bolt or nut has been properly tightened.

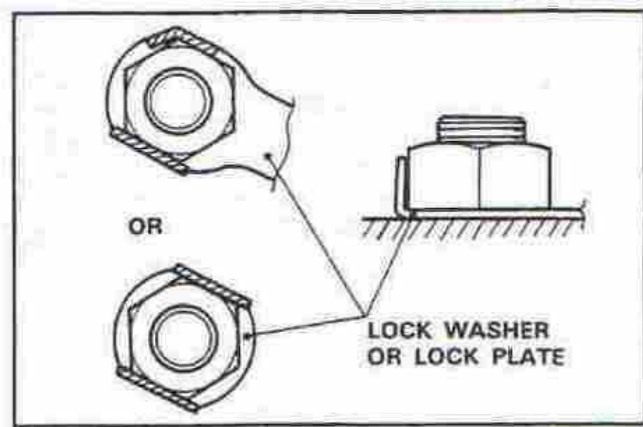

#### Bearings and Oil Seals

1. Install the bearing(s) and oil seal(s) with their manufacturer's marks or numbers facing outward. (In other words, the stamped letters must be on the side exposed to view). When installing oil seal(s), apply a light coating of lightweight lithium base grease to the seal lip(s). When installing bearings liberally oil the bearings.

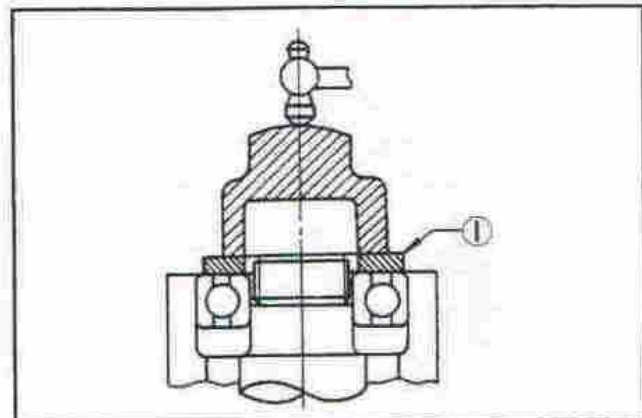

1. Bearing

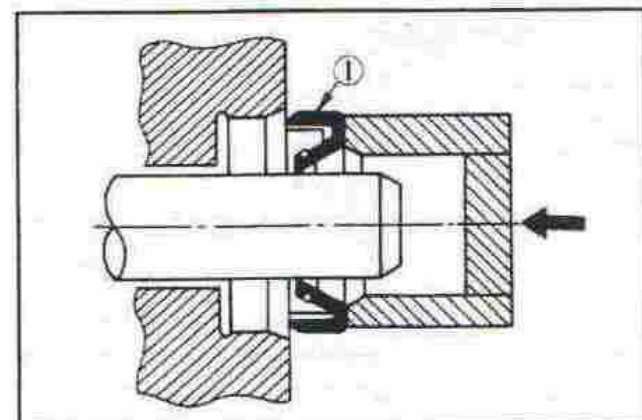

1. Oil seal

# Left-Side Crankcase

## PISTON:

**PISTON CLEARANCE:**  
 0.040 - 0.048 mm (0.0016 - 0.0019 in)  
**OVER SIZE:**  
 1ST: 44.25 mm (0.74 in)  
 2ND: 44.50 mm (1.75 in)

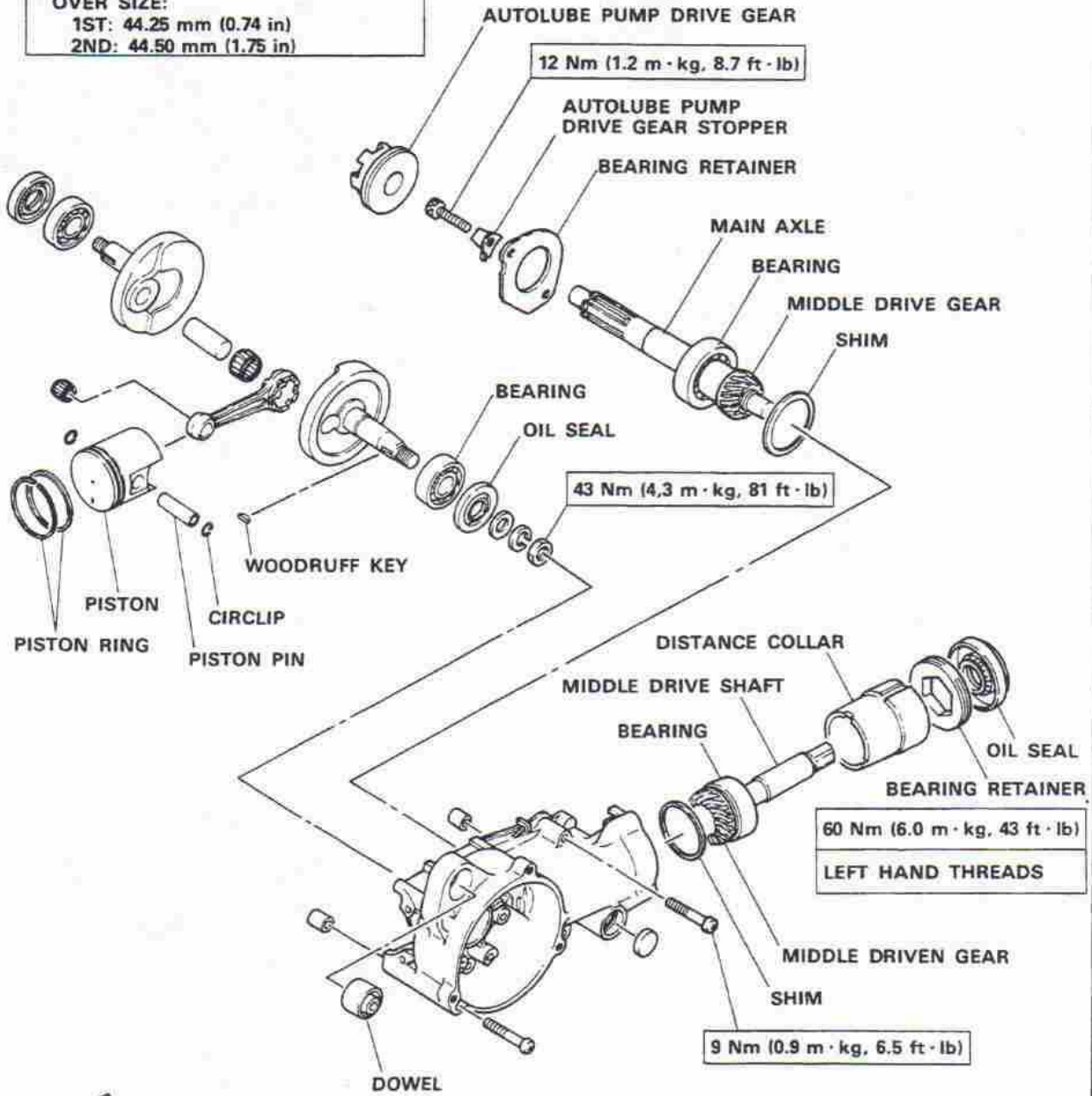

## CRANKSHAFT:

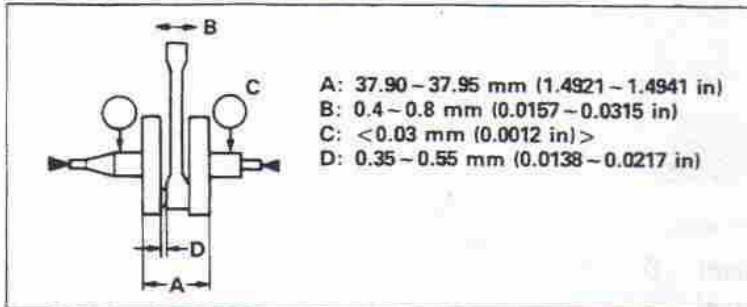

**MIDDLE GEAR LASH:**  
 0.04 - 0.60 mm (0.0016 - 0.0236 in)

1. Install the crankshaft oil seal into the crankcase. Liberally oil the oil seal lips before installation. The oil seal i.d. marks should face outside of the crankcase.
2. Press the main-axle-bearing and middle-drive-shaft-bearing onto each shaft. Liberally oil the bearings before installation.

**CAUTION:** \_\_\_\_\_

Push the inner, not the outer race.

3. Install the middle drive shaft assembly with the original shim into the left-side crankcase.

**CAUTION:** \_\_\_\_\_

The middle drive shaft assembly is a slip fit. If the bearing and/or distance collar cocks during installation, remove the middle drive shaft assembly and start again. The bearing and/or distance collar must go in smoothly.

4. Install the middle-drive-shaft bearing retainer. Using the Hexagon Wrench (25 mm), torque the retainer to specification.

**NOTE:** \_\_\_\_\_

The bearing retainer nut has left-hand threads; turn the nut counterclockwise to tighten it.

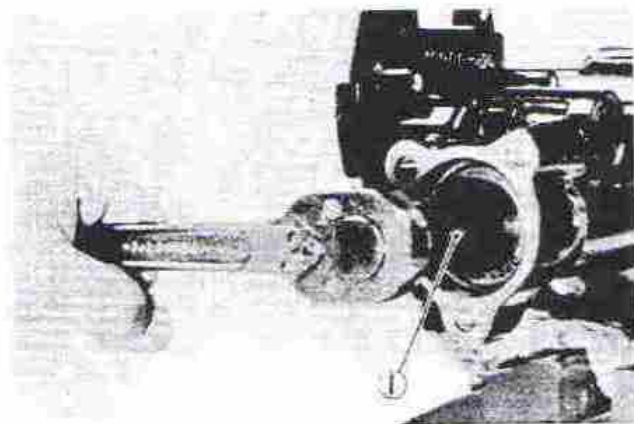

1. Hexagon Wrench (25 mm)

5. Install the middle-drive-shaft oil seal into the crankcase as shown.

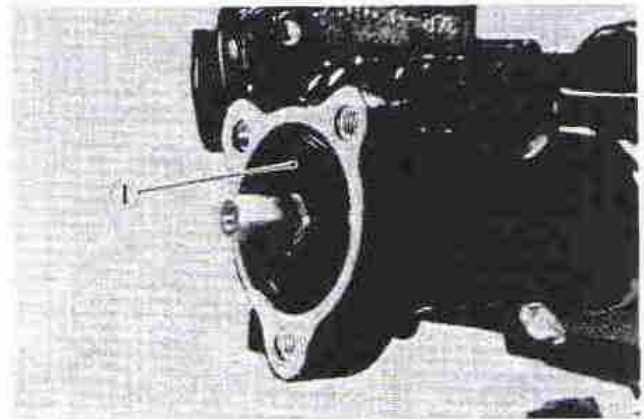

1. Oil seal

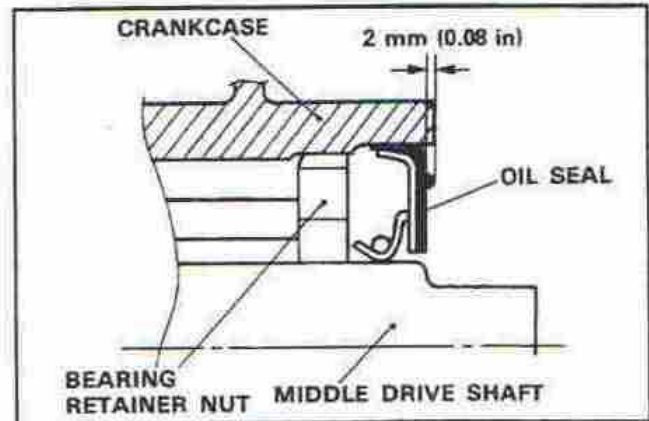

6. Install the main axle assembly with the original shim into the crankcase.

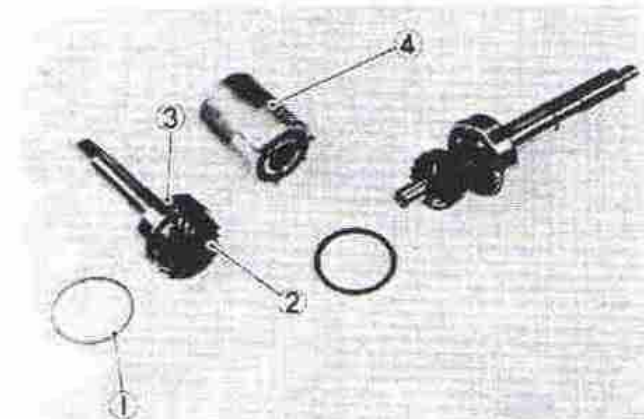

1. Shim  
2. Main axle

3. Bearing  
4. Distance collar

7. Install the main axle bearing retainer and Autolube-pump-drive-gear stopper onto the crankcase. Torque the bolts to specification.

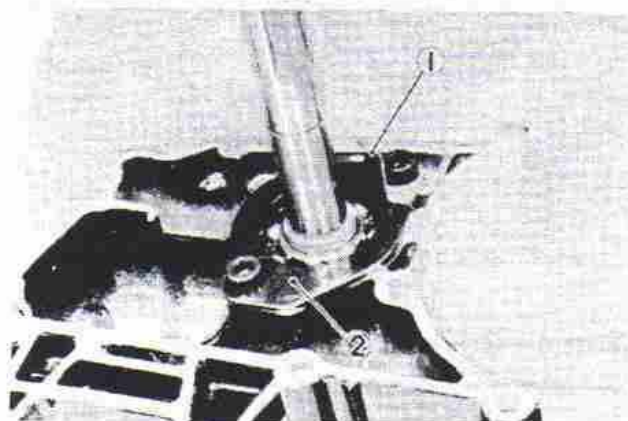

1. Gear stopper 2. Bearing retainer

**TIGHTENING TORQUE:**

12 Nm (1.2 m · kg, 8.7 ft · lb)

8. Install the crankshaft into the left-side crankcase. Use the crankshaft installing tool. Align the connecting rod with the cylinder sleeve hole. The rod must be in this hole when the crankshaft is properly installed.

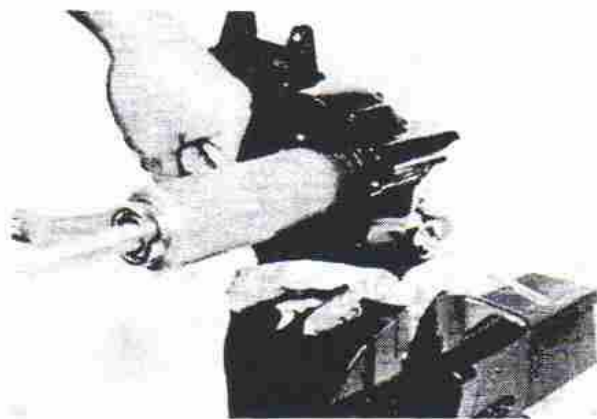

**Right-Side Crankcase**

1. Press the crankshaft bearing into the crankcase. Liberally oil the bearing before installation.

**CAUTION:**

Push the outer, not the inner race.

2. Install the crankshaft oil seal into the crankcase. Liberally oil the oil seal lips before installation. The oil seal i.d. marks should face outside of the crankcase.
3. Install the two dowels into the left-side crankcase as shown.

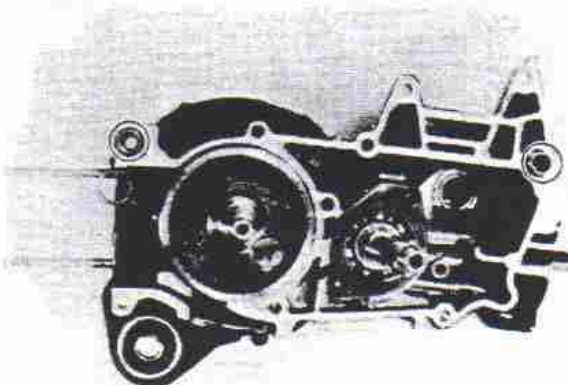

4. Install the right-side crankcase onto the left-side crankcase.

**NOTE:**

Use Yamabond #4® to seal the cases.

5. Install the lower-engine-mounting bracket and crankcase bolts. Tighten the bolts to specification.

**TIGHTENING TORQUE:**

Crankcase:

9 Nm (0.9 m · kg, 6.5 ft · lb)

Lower-Engine-Mounting Bracket:

10 Nm (1.0 m · kg, 7.2 ft · lb)

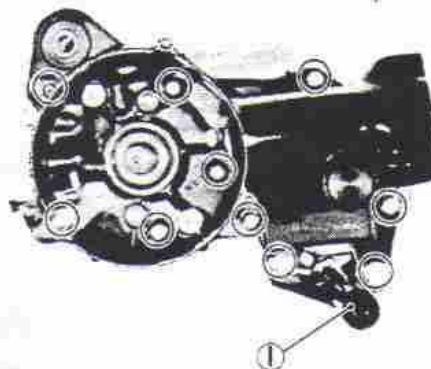

1. Lower engine mounting bracket

6. Install the collar onto the crankshaft, and install the crankshaft-oil-seal retainer onto the right-side crankcase. Torque the bolt to specification.



**TIGHTENING TORQUE:**  
9 Nm (0.9 m·kg, 6.5 ft·lb)

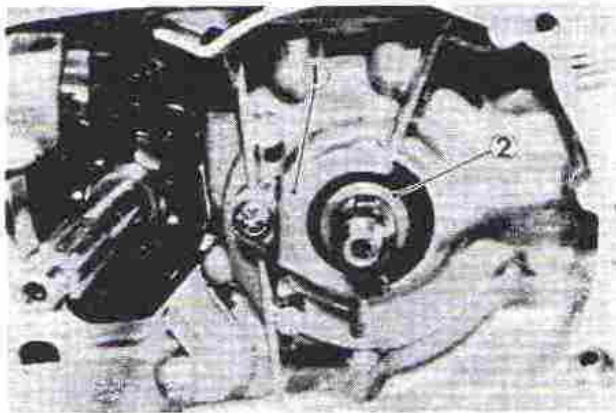

1. Oil seal retainer 2. Collar

### Flywheel Magneto

1. Install the C.D.I. magneto base onto the left-side crankcase. Torque the screws to specification.

**TIGHTENING TORQUE:**  
9 Nm (0.9 m·kg, 6.5 ft·lb)

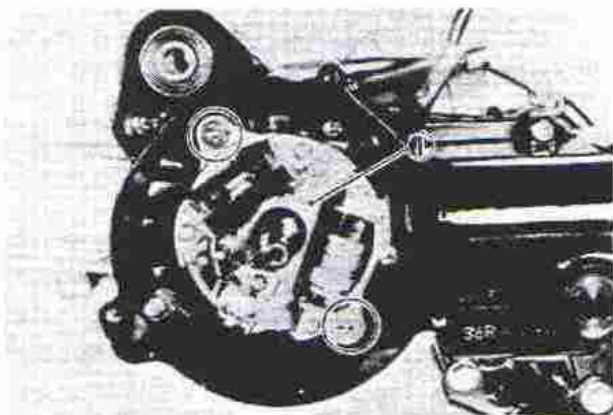

1. C.D.I. magneto base

2. Install the woodruff key into the crankshaft keyway.
3. Install the flywheel assembly onto the crankshaft. The key in the crankshaft should engage the keyway in the flywheel.
4. Install the washers and the flywheel securing nut onto the crankshaft. Hold the flywheel magneto with the universal rotor holder and torque the nut to specification.

**TIGHTENING TORQUE:**  
43 Nm (4.3 m·kg, 31 ft·lb)

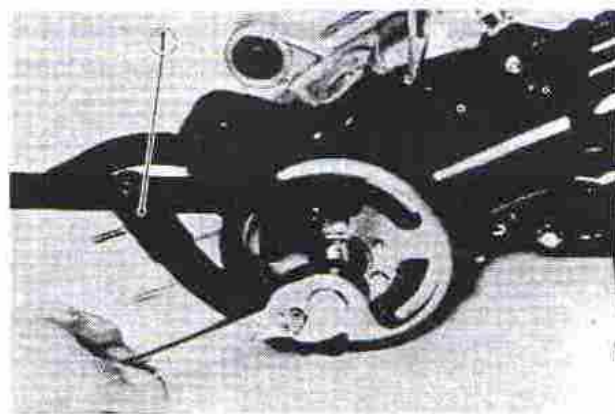

1. Universal rotor holder

### Primary Drive Gear and Clutch

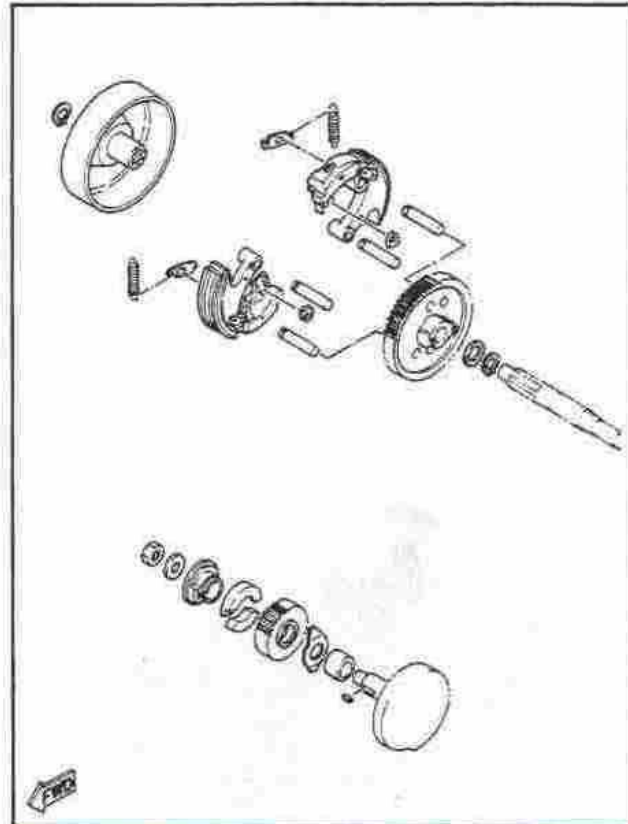

1. Install the thrust washer onto the crankshaft.
2. Install the primary drive gear, key, washer, and nut in that order.

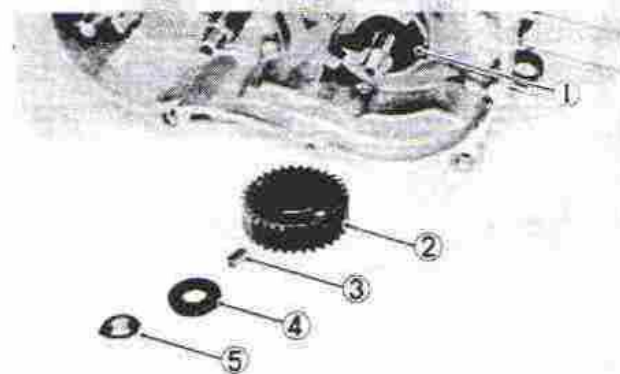

1. Thrust washer
2. Primary drive gear
3. Key
4. Washer
5. Nut

**NOTE:** \_\_\_\_\_

Study the primary drive gear. Note that it has two different length rubber dampers inside. So when assembling the drive gear, make sure that smaller one should be installed under the "S" mark on the drive gear boss as shown.

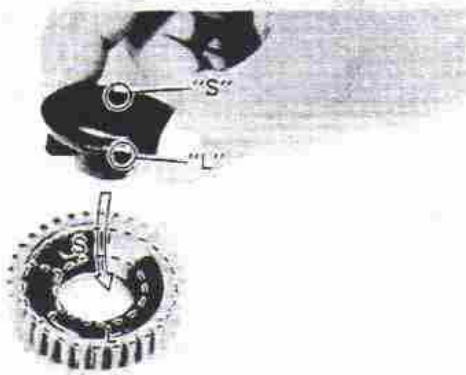

3. Hold the flywheel with the universal rotor holder, and torque the securing nut to specification.

**TIGHTENING TORQUE:**  
30 Nm (3.0 m·kg, 22 ft·lb)

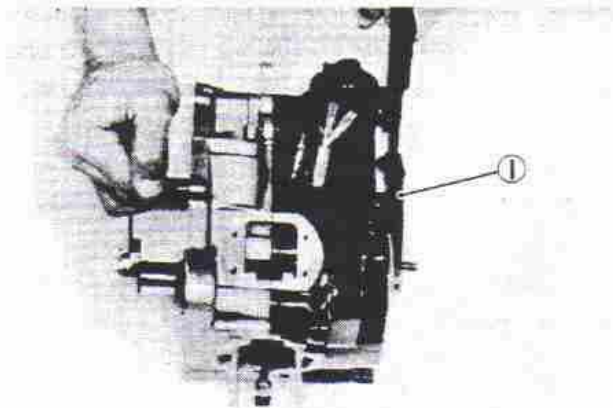

1. Universal rotor holder

4. Install the Autolube pump drive gear and circlip onto the main axle.

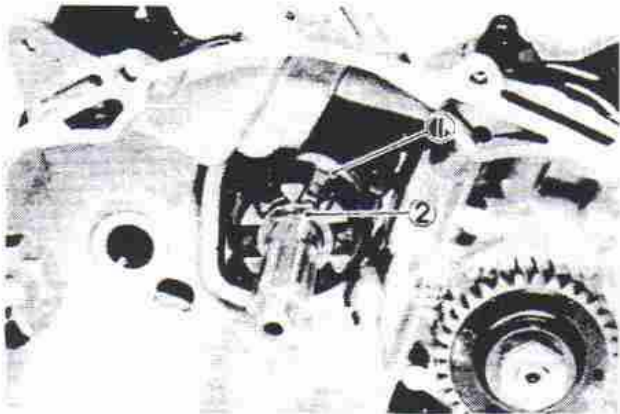

1. Drive gear 2. Circlip

5. Install the washer and clutch shoe/driven gear assembly onto the main axle.

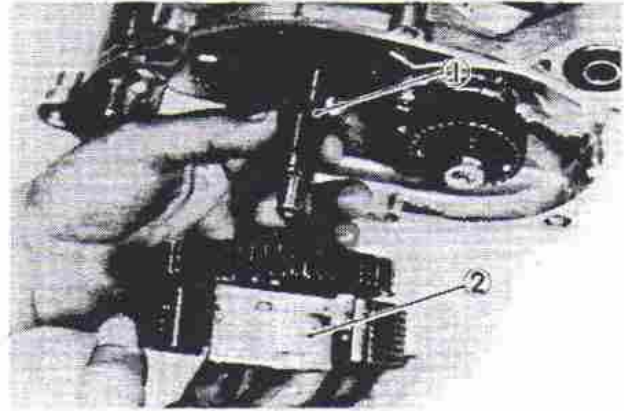

1. Washer 2. Clutch shoe/driven gear assembly

6. Install the clutch housing and circlip onto the main axle.

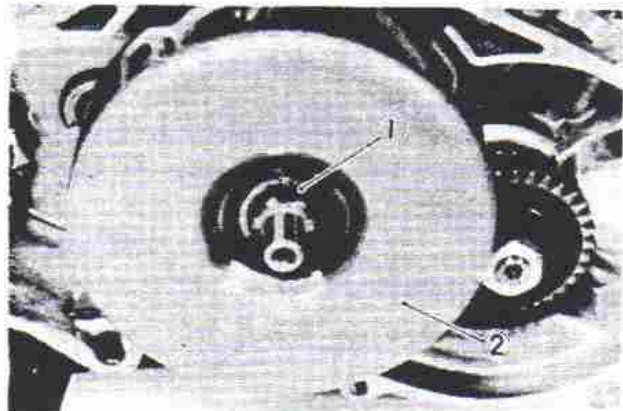

1. Circlip 2. Clutch housing

**Right Crankcase Cover, Carburetor Joint, and Autolube Pump**

1. Install the crankcase breather pipe into the right-side crankcase; apply Yamabond #4® to the crankcase breather hole and align the crankcase breather hole end with the white paint mark on the pipe.

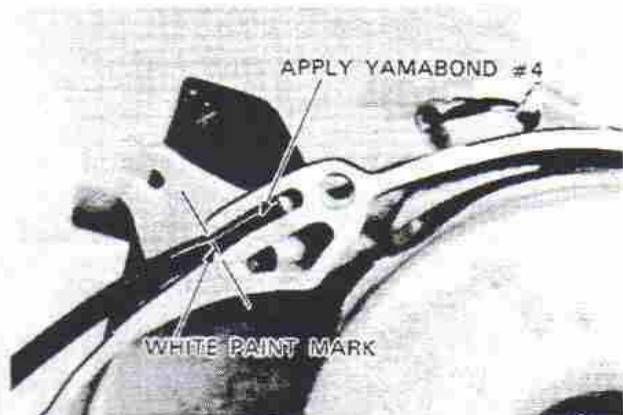

2. Install the two dowels in the right-side crankcase.

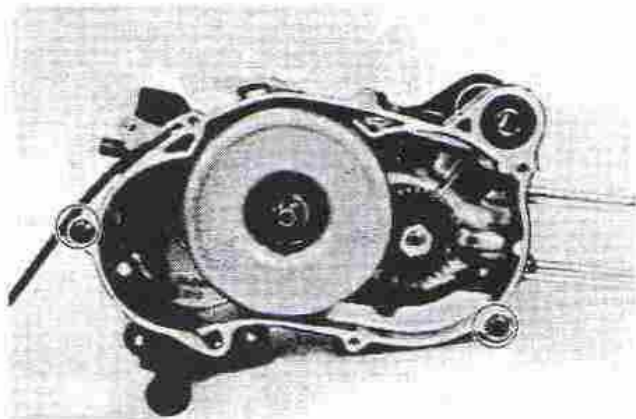

3. Install the crankcase cover with a new gasket. Torque the bolts to specification.

**TIGHTENING TORQUE:**  
9 Nm (0.9 m·kg, 6.5 ft·lb)

4. Install the reed valve and carburetor joint onto the crankcase. Torque the bolt to specification.

**TIGHTENING TORQUE:**  
9 Nm (0.9 m·kg, 6.5 ft·lb)

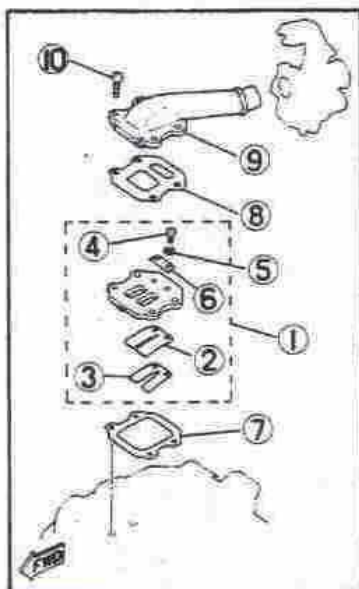

1. Reed valve assembly
2. Reed valve
3. Reed valve stopper
4. Panhead screw
5. Spring washer
6. Reed valve plate
7. Valve seat gasket 1
8. Valve seat gasket 2
9. Carburetor joint
10. Panhead screw

5. Install the Autolube pump cover and pump assembly onto the crankcase.

**TIGHTENING TORQUE:**  
4 Nm (0.4 m·kg, 2.9 ft·lb)

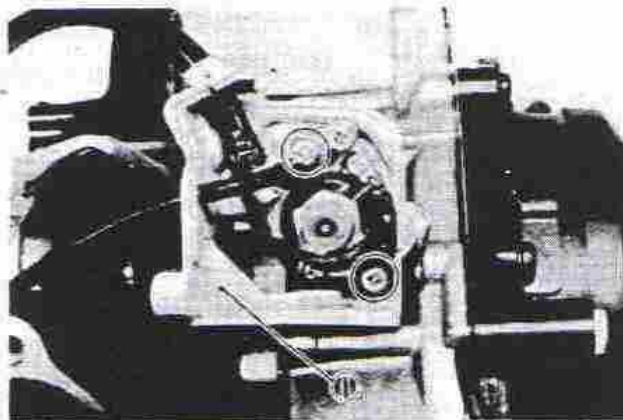

1. Cover

### Piston, Cylinder, Cylinder Head, and Recoil Starter

#### NOTE:

During reassembly, coat the piston ring grooves, piston skirt areas, piston pin, and connecting rod bearings with Yamalube 2-cycle oil or equivalent.

1. Install the piston on the rod. The arrow mark on the piston should face the front of the engine. Use new piston-pin clips.

#### NOTE:

Before installing the piston pin clips, cover the crankcase with a clean rag so you will not accidentally drop the clip into the crankcase.

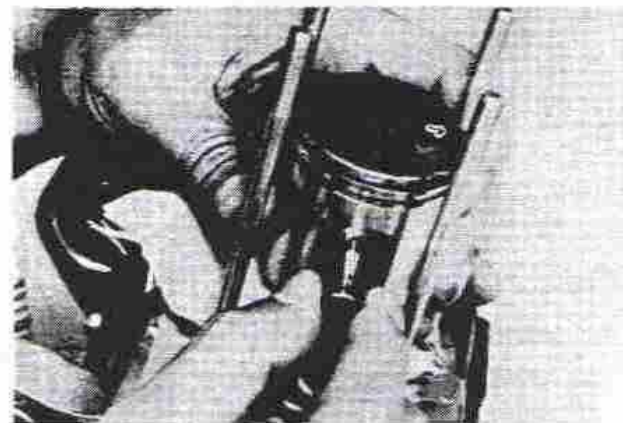

2. Install a new cylinder base gasket onto the crankcase.
3. Install the cylinder. You do not need piston ring compressor to install the cylinder liner. Simply compress the piston rings with your fingers.

#### NOTE:

Make sure the rings are properly positioned.

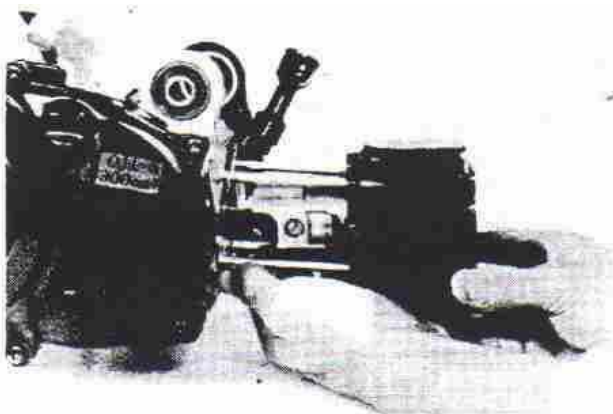

4. Install the cylinder head with a new head gasket. Torque the nut to specification.

**TIGHTENING TORQUE:**

10 Nm (1.0 m·kg, 7.2 ft·lb)

5. Install the recoil starter pulley on the flywheel magneto. Hold the flywheel magneto with the rotor holding tool, and torque the pulley securing bolts to specification.

**TIGHTENING TORQUE:**

10 Nm (1.0 m·kg, 7.2 ft·lb)

6. Install the recoil starter assembly. Torque the bolts to specification.

**TIGHTENING TORQUE:**

4 Nm (0.4 m·kg, 2.9 ft·lb)

**Rear Wheel Drive Assembly**

1. Place the engine on a block or other suitable engine stand.
2. Lightly grease the square recesses of the drive shaft, and install the drive shaft into the drive shaft housing.

**NOTE:**

The damper spring faces toward the rear.



1. Drive shaft

3. Apply Yamabond #4® to the contact surfaces of drive shaft housing and engine.
4. Connect the engine and rear wheel drive assembly, and torque the bolts to specification.

**TIGHTENING TORQUE:**

26 Nm (2.6 m·kg, 19 ft·lb)

**Mounting the Engine**

1. Install the frame over the engine.



2. Install the upper engine mounting bolt and engine-mounting-bracket securing bolts. Finger-tighten the bolts; do not tighten them at this point.





3. Install the bolts securing the final gear housing and rear wheel hub.

**NOTE:**

Apply Yamabond #4<sup>®</sup> to the front-final-housing-securing-bolt where as shown in the photograph.



4. Evenly tighten all final gear housing and rear wheel hub securing bolts to specification.

**TIGHTENING TORQUE:**

Final Gear Housing & Frame:  
50 Nm (5.0 m·kg, 36 ft·lb)  
Rear Wheel Hub & Frame:  
50 Nm (5.0 m·kg, 36 ft·lb)

5. Tighten the engine mounting bolts to specification.

**TIGHTENING TORQUE:**

Upper Engine Mounting:  
48 Nm (4.8 m·kg, 35 ft·lb)  
Lower Engine Mounting Bracket & Frame:  
10 Nm (1.0 m·kg, 7.2 ft·lb)

6. Install the carburetor assembly and inlet hose.
7. Connect the brake and Autolube pump cables, and adjust the brake, Autolube pump, throttle, and starter (Choke) cables. Refer to "CHAPTER 2" for adjustments.
8. Connect the C.D.I. magneto leads and oil pipes.

**WARNING:**

If the Autolube pump system is disassembled or if any oil hose has been removed, the Autolube system must be bled to remove air from the Autolube pump. Refer to "Autolube Pump".

9. Install the exhaust pipe onto the cylinder, and torque the bolts to specification.

**TIGHTENING TORQUE:**

9 Nm (0.9 m·kg, 6.5 ft·lb)

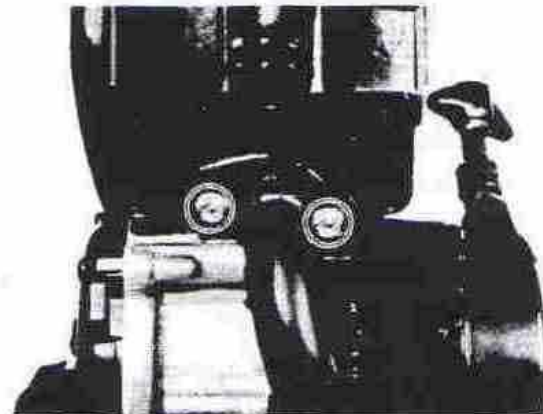

10. Install the muffler assembly, and torque the bolts to specification.

**TIGHTENING TORQUE:**

Muffler:  
27 Nm (2.7 m·kg, 19 ft·lb)  
Silencer:  
12 Nm (1.2 m·kg, 8.7 ft·lb)  
Silencer Clamp:  
20 Nm (2.0 m·kg, 14 ft·lb)

11. Install the seat and body cowl assembly.

# CHAPTER 4 CARBURETION

<b>CARBURETOR</b> .....	4-1
Specifications .....	4-2
Disassembly .....	4-2
Inspection .....	4-2
Assembly .....	4-3
Float Height and Fuel Level Measurements .....	4-3
<b>REED VALVE ASSEMBLY</b> .....	4-4
Inspection .....	4-4

# CHAPTER 4. CARBURETION

## CARBURETOR

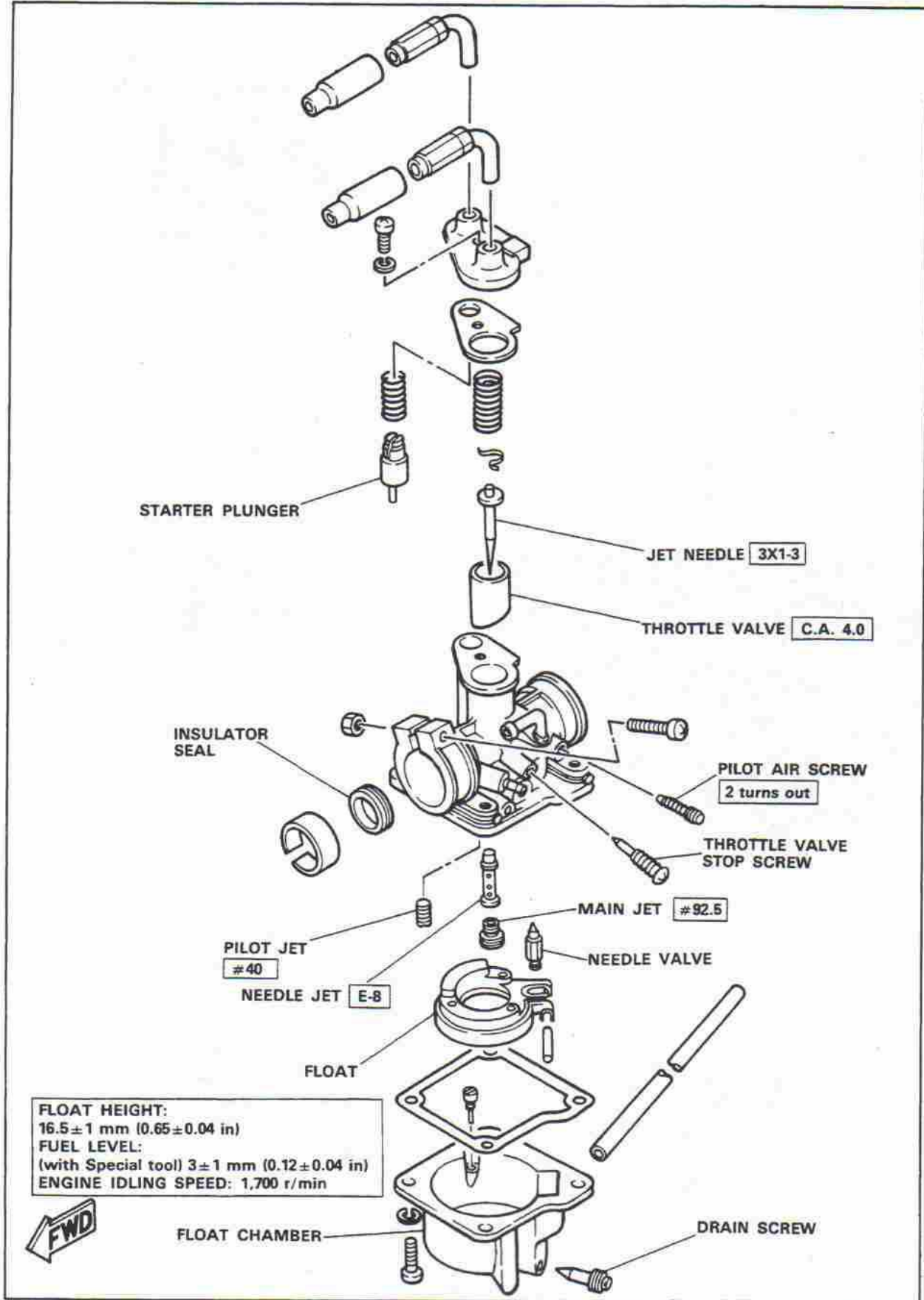

## Specifications

Main Jet	(M.J.)	#92.5
Jet Needle	(J.N.)	3X1-3
Pilot Jet	(P.J.)	#40
Pilot Air Screw	(P.A.S.)	2 (turns out)
Float Valve Seat		ø1.2
Fuel Level		3 ± 1 mm (0.12 ± 0.04 in)
Float Height		16.5 ± 1 mm (0.65 ± 0.04 in)
Engine Idle Speed		1,700 r/min.

## Disassembly

1. Remove the seat and body cowl assembly.
2. Turn the fuel cock to "OFF".
3. Disconnect the fuel hose from the carburetor.
4. Disconnect the oil delivery hose from the carburetor.
5. Remove the carburetor top cover securing screw, and pull out the throttle valve and starter plunger.

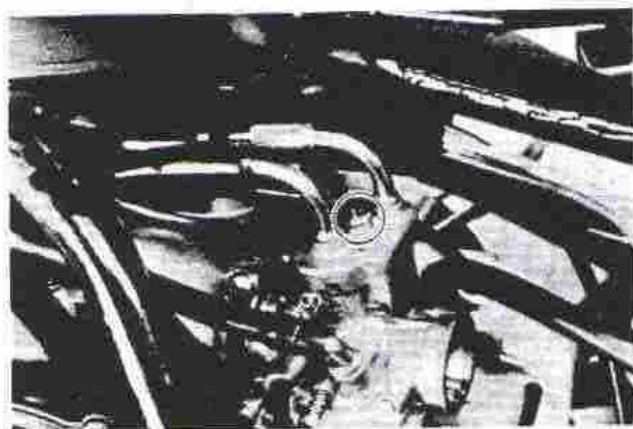

6. Remove the air cleaner inlet hose clip, and loosen the carburetor securing screw. Remove the carburetor assembly.
7. Remove the float chamber securing screw and remove the float chamber.



8. Remove the float pivot pin, and remove the float assembly. Be careful not to close the float valve which is under the float arm.

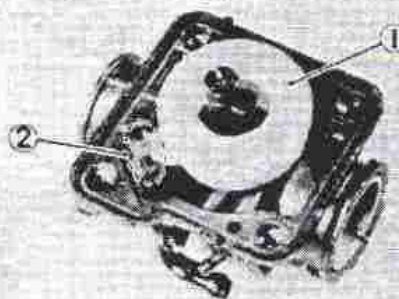

1. Float 2. Pivot pin

9. Remove the jets, and main nozzle if necessary.

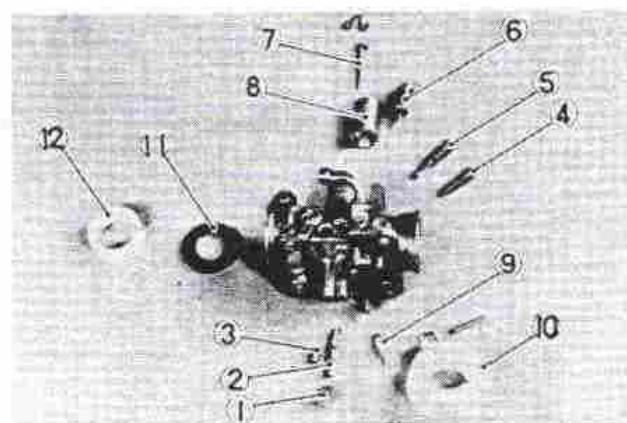

1. Main Jet  
2. Main nozzle  
3. Pilot jet  
4. Pilot air screw  
5. Throttle stop screw  
6. Starter plunger  
7. Jet needle  
8. Throttle valve  
9. Needle valve  
10. Float  
11. O-ring  
12. Collar

## Inspection

1. Examine the carburetor body and fuel passages. If they are contaminated, wash the carburetor in a petroleum-base solvent. Do not use any caustic carburetor cleaning solutions. Blow out all passages and jets with compressed air.
2. Examine the condition of the float. If the float is damaged, it should be replaced.



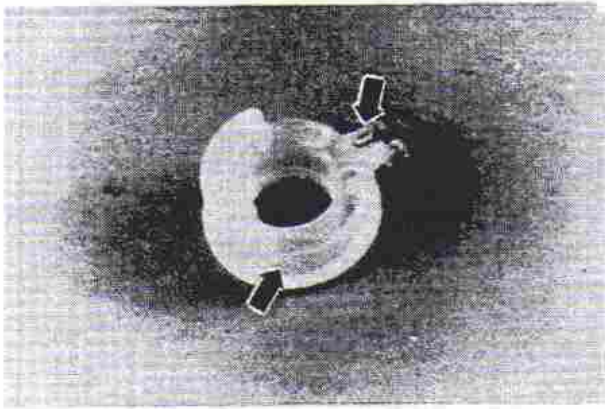

3. Inspect the float needle valve and seat (carburetor body) for wear or contamination. Replace the needle valve or carburetor assembly.

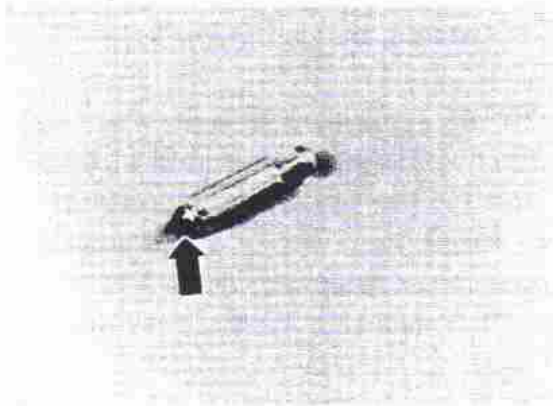

4. Inspect the jet needle for bends or wear. If the needle is bent or severely worn, replace it.

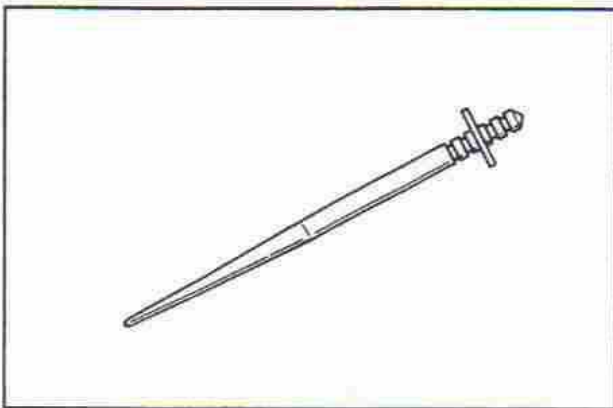

5. Inspect the starter plunger. If it is worn or damaged, replace it.

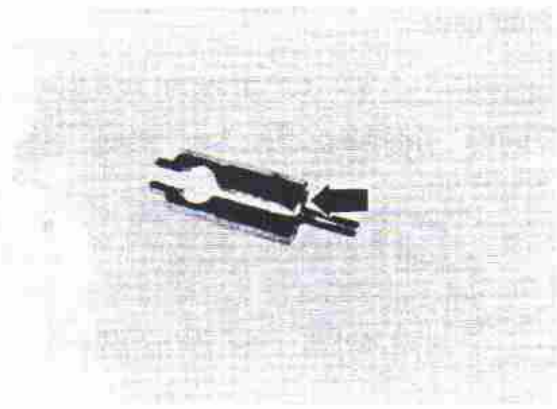

### Assembly

1. To assemble the carburetor, reverse the disassembly procedures. Pay close attention to the location of each jet.

### Float Height and Fuel Level Measurements

#### Float Height

Hold the carburetor in an upside down position. Incline the carburetor at  $60^\circ \sim 70^\circ$  (so that the end of the needle valve does not hang down of float weight), and measure the distance from the mating surface of the float chamber (without the gasket) to the top of the float.

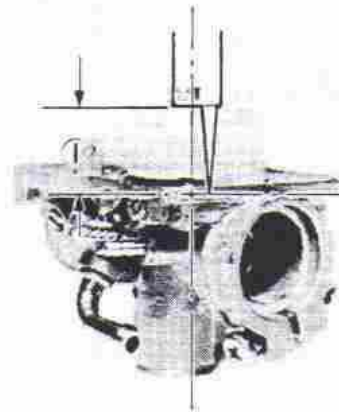

1. Float height

Float Height:  
 $16.5 \pm 1 \text{ mm}$  ( $0.65 \pm 0.04 \text{ in}$ )

**NOTE:** \_\_\_\_\_

Before checking the fuel level, note the following:

- \* Place the machine on the level surface.
- \* Adjust the machine position by placing a suitable stand or a garage jack under the engine so that the carburetor is positioned vertically.

1. Disconnect the drain pipe from the float chamber.
2. Insert one end of a pipe, 3.5 mm (0.14 in) in inside diameter, 6 mm (0.24 in) in outside diameter, and 50 mm (2.00 in) in length about 10 mm (0.39 in) into the fuel level gauge pipe, and insert the other end into the drain nozzle.

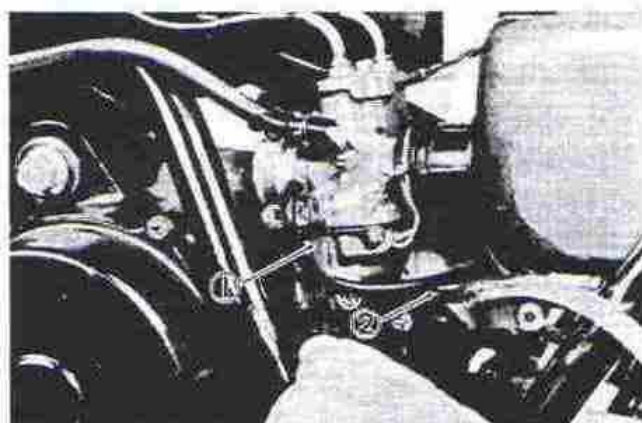

1. Special tool 2. Pipe

3. As shown above, hold the level gauge vertically, and loosen the carburetor drain screw.
4. Set the fuel cock to "ON" and start the engine. Stop it after a few minutes.
5. Check the fuel level. It should be within specified range.

Fuel Level (with special tool):  
 $3 \pm 1$  mm ( $0.12 \pm 0.04$  in)

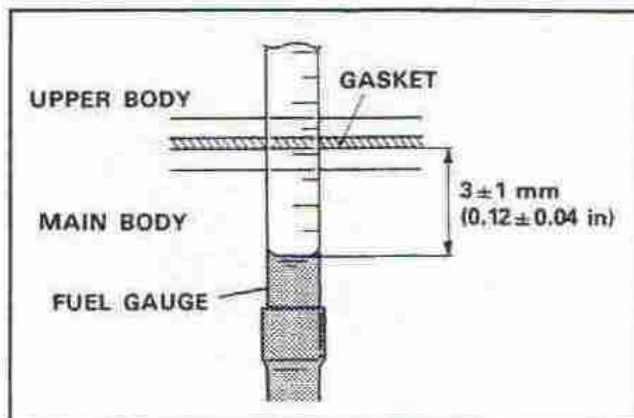

6. If the float height and/or fuel level is not within specification, remove the carburetor, and check the needle valve, valve seat (carburetor body), and float.
7. If no damage is found in these parts, replace the carburetor assembly.

**NOTE:** \_\_\_\_\_

The float height and fuel level are properly adjusted at the Yamaha factory. Never attempt to adjust it.

## REED VALVE ASSEMBLY

### Inspection

1. Handling the reed valve  
The reed valve is operated by changes in crankcase pressure and by the inertia force of the fuel-air stream. It is a high-precision piece, and therefore, it must be handled with special care.
2. Storage  
The reed valve must be stored in a clean and dry place and must be kept off the sun. Particularly, it must be kept free from salt. Avoid touching the valve.
3. Inspect reed petals for signs of fatigue and cracks. Reed petals should fit flush or nearly flush against neoprene seats. If in doubt as to sealing ability, apply suction to carburetor side of assembly. Leakage should be slight to moderate.

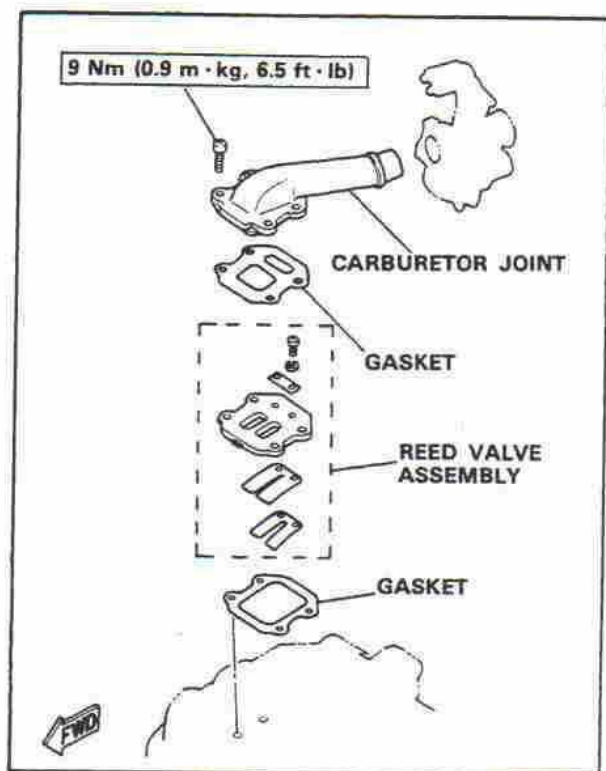

#### 4. Valve stopper

The valve stopper controls the movement of the valve. Check clearance "a".

Valve Stopper Clearance:

$4.8 \pm 0.2$  mm (0.19  $\pm$  0.008 in)

Reed Distortion Limit:

0.3 mm (0.012 in)

#### NOTE:

If clearance "a" is larger than specified, the valve will be broken. If smaller, engine performance can be impaired.

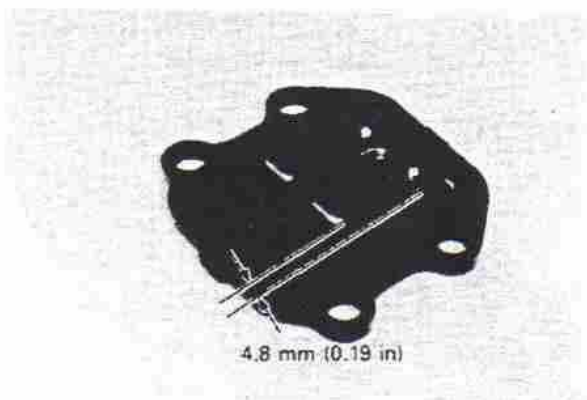

Valve Stopper Screw Torque:

0.8 Nm (0.08 m·kg, 0.6 ft·lb)

#### 5. Reed valve

- a. Place the reed valve on a surface plate, with the reverse side down, and measure the amount of warpage. If measured is more than the limit, the reed valve should be replaced.

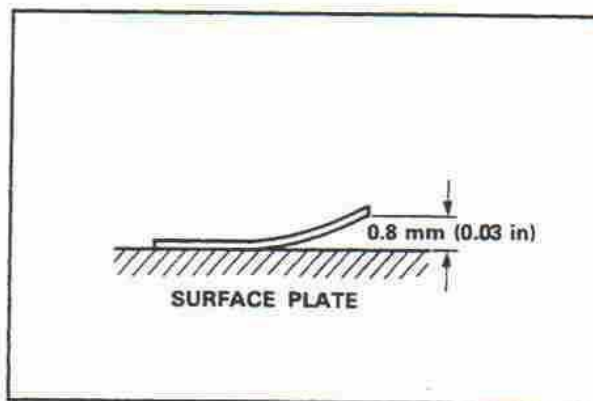

Warpage Limit: 0.8 mm (0.03 in)

- b. There should be no gap between the reed valve end and valve seat, when it is installed.

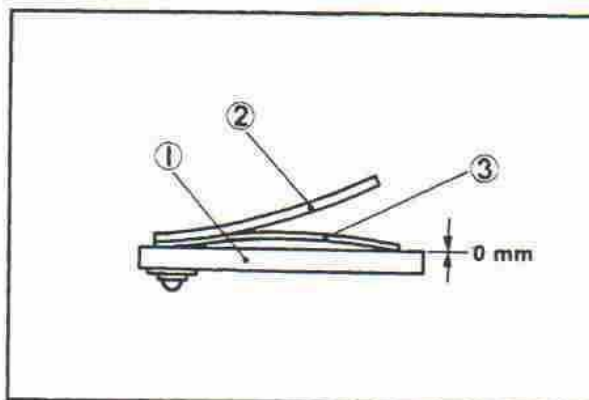

1. Valve seat 2. Reed valve stopper 3. Reed valve

6. Carburetor joint

Check distortion of carburetor joint surface. If distortion is out of limit, resurface it on the #600 wet sandpaper.

Warp Limit: 0.1 mm (0.004 in)

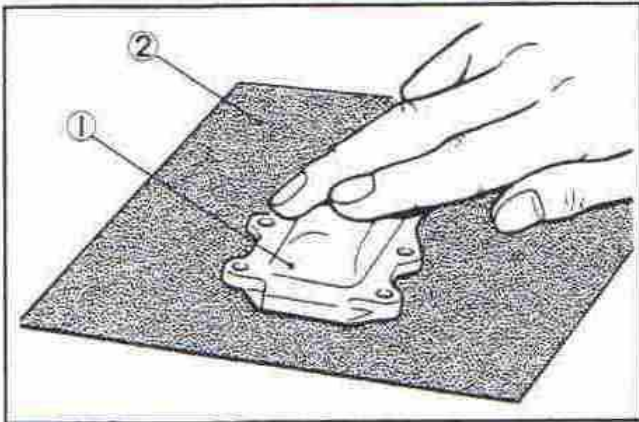

1. Carburetor joint 2. Sandpaper (#600)

# CHAPTER 5

## CHASSIS

<b>FRONT WHEEL</b> .....	5-1
Front Wheel Removal .....	5-1
Front Axle Inspection .....	5-1
Front Wheel Inspection .....	5-1
Replacing the Wheel Bearings .....	5-1
Front Wheel Installation .....	5-2
<b>REAR WHEEL</b> .....	5-2
Rear Wheel Removal .....	5-2
Rear Wheel Inspection .....	5-2
Rear Wheel Installation .....	5-2
<b>REAR BRAKE</b> .....	5-3
Brake Drum .....	5-3
Brake Shoe Plate .....	5-3
Checking Brake Shoe Wear .....	5-3
Assembly .....	5-4
<b>SHAFT DRIVE AND REAR WHEEL BEARINGS</b> .....	5-5
Troubleshooting .....	5-6
Removal .....	5-8
Inspection .....	5-9
Assembly .....	5-10
<b>DRIVE SHAFT</b> .....	5-12
Removal .....	5-12
Inspection .....	5-12
Assembly .....	5-12
<b>FRONT FORKS AND STEERING HEAD</b> .....	5-13
Removal and Disassembly .....	5-14
Inspection .....	5-14
Assembly .....	5-15
<b>CABLES AND FITTINGS</b> .....	5-16
Cable Maintenance .....	5-16

## FRONT WHEEL

### Front Wheel Removal

1. Elevate the front wheel by placing a suitable stand under front fork.
2. Remove cotter pin from front wheel axle and remove axle nut.
3. Remove the front wheel axle, collar, and front wheel assembly from the front fork.

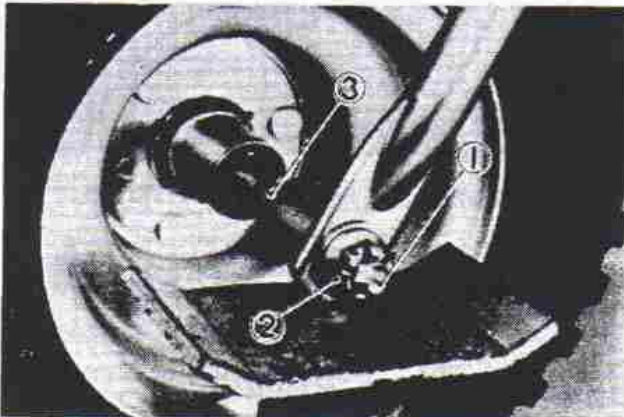

1. Cotter pin 2. Axle nut 3. Collar

### Front Axle Inspection

Remove any corrosion from the axle with emery cloth. Place the axle on a surface plate and check for bend. If bent, replace the axle. Do not attempt to straighten a bend.

### Front Wheel Inspection

1. Check for cracks, bends or warpage of the wheels. If a wheel is deformed or cracked, it must be replaced.
2. Check wheel runout  
If deflection exceeds tolerance below, check the wheel bearing or replace wheel as required.

#### Rim Runout Limits:

Vertical — 2.0 mm (0.08 in)  
Lateral — 2.0 mm (0.08 in)

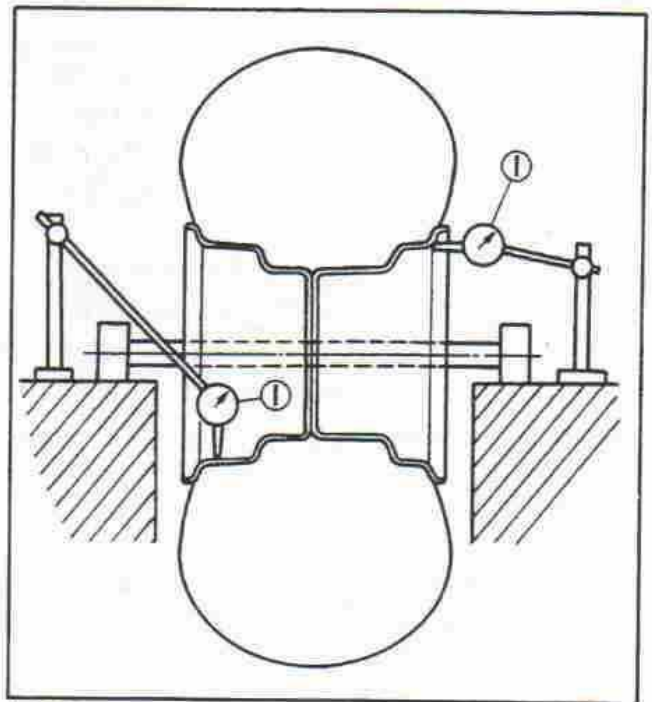

1. Dial gauge

### Replacing the Wheel Bearings

If the bearings allow play in the wheel hub or if the wheel does not turn smoothly, replace the bearings as follows:

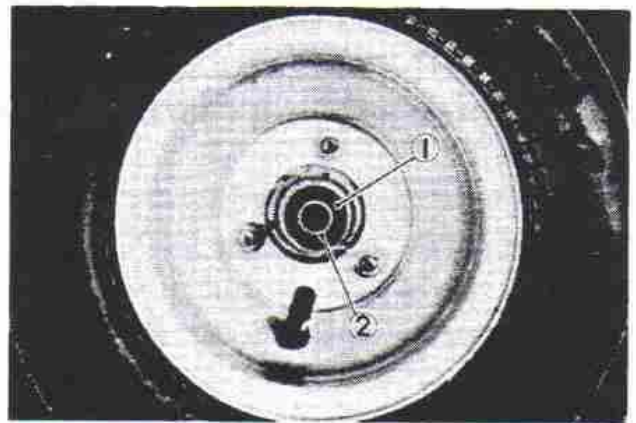

1. Oil seal 2. Bearing

1. Clean the outside of the wheel hub.
2. Drive the bearing out by pushing the spacer aside and tapping around the perimeter of the bearing inner race with a soft metal drift punch and hammer. The spacer "floats" between the bearings. Both bearings can be removed in this manner.

**WARNING:**

Eye protection is recommended when using striking tools.

3. To install the wheel bearing, reverse the above sequence. Use a socket that matches the outside diameter of the race of the bearing to drive in the bearing.

**CAUTION:**

Do not strike the center race or balls of the bearing. Contact should be made only with the outer race.

**Front Wheel Installation**

When installing front wheel, reverse the removal procedure taking the following steps:

1. Tighten the front axle nut.

**TIGHTENING TORQUE:**  
50 Nm (5.0 m·kg, 36 ft·lb)

2. Insert the new cotter pin into the front wheel nut.

**WARNING:**

Always use a new cotter pin on the axle nut.

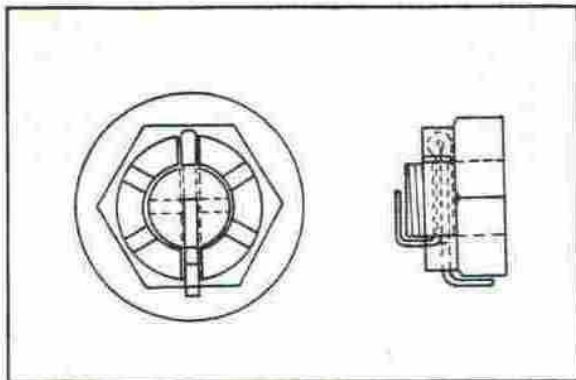

**REAR WHEEL**

**Rear Wheel Removal**

1. Elevate the rear wheel by placing a suitable stand under the rear wheel axle.
2. Remove the nuts from rear wheel panel.

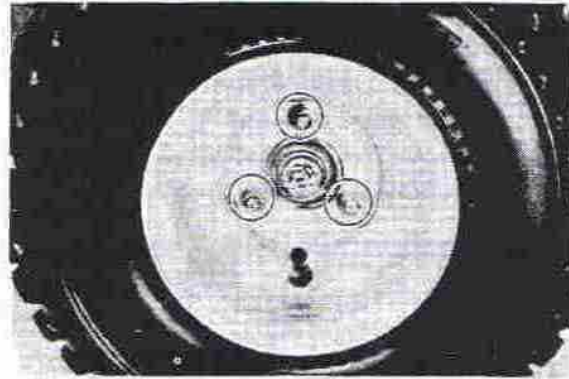

3. Remove the rear wheel assembly.

**Rear Wheel Inspection**

See "Front Wheel Inspection".

**Rear Wheel Installation**

When installing rear wheel, reverse the removal procedure.

1. Torque the rear wheel nut.

**TIGHTENING TORQUE:**  
28 Nm (2.8 m·kg, 20 ft·lb)

## REAR BRAKE

1. Block the front tire and raise the rear of the machine.
2. Loosen the brake cable adjuster on the brake lever.

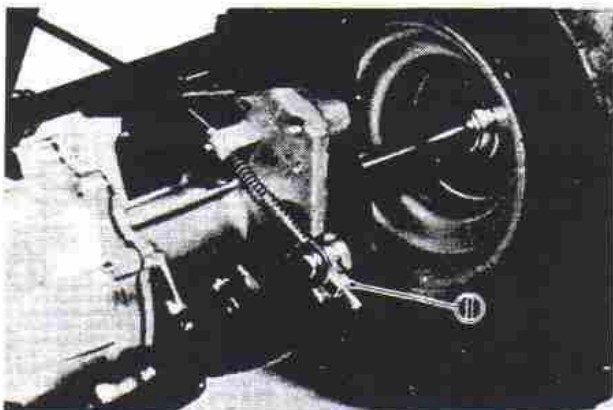

1. Adjuster

3. Remove the right-side-rear wheel, axle nut, and rear wheel flange from the rear axle.
4. Remove the rear brake cover.

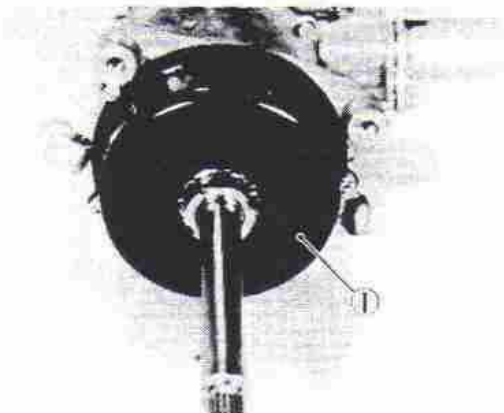

1. Rear brake cover

5. Flatten the lock washer tab, and remove the ring nut. Remove the ring nut, lock washer, and brake drum from the rear axle.

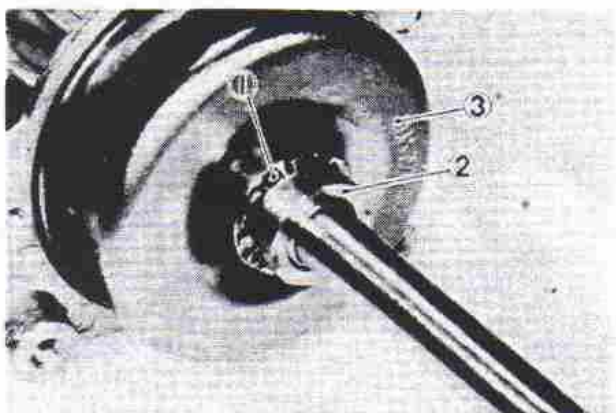

1. Lock washer 2. Ring nut 3. Brake drum

## Brake Drum

Oil or scratches on the inner surface of the brake drum will impair braking performance or result in abnormal noises. Remove oil by wiping the brake drum with a rag soaked in lacquer thinner or solvent, and replace the right-side-rear-wheel-housing oil seal and O-ring. Remove scratches by lightly and evenly polishing the brake drum with emery cloth.

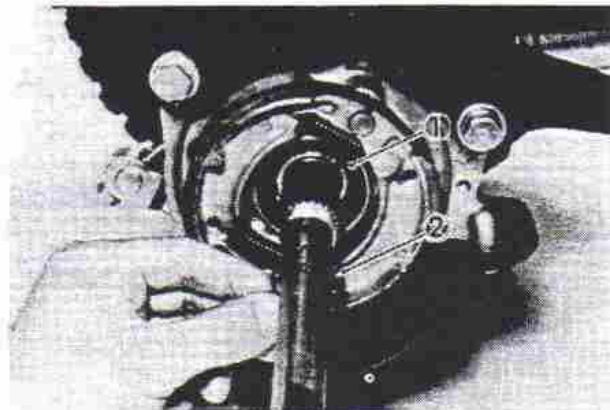

1. Oil seal 2. O-ring

## Brake Shoe Plate

Remove the camshaft, and grease it. If the cam face is worn, replace the camshaft.

## NOTE:

Before removing the cam lever, put alignment marks on the cam lever and camshaft to indicate their relative positions for easy assembly.

## Checking Brake Shoe Wear

1. Check the brake linings for damage and wear. If the thickness is less than the specified value, replace the brake shoe as a set.

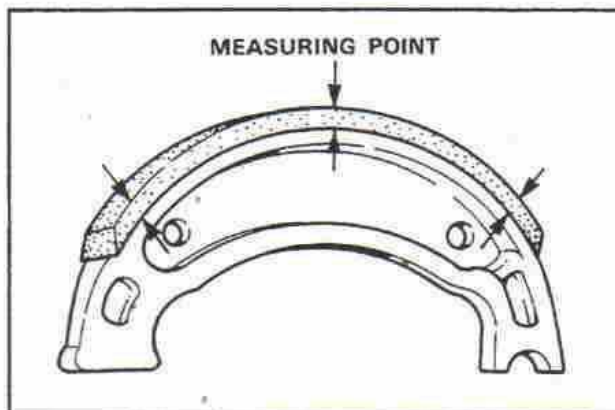



Wear Limit: 2 mm (0.08 in)

### Assembly

1. To assemble the rear brake, reverse the disassembly procedures. Torque the bolts and nuts to specification.

### WARNING:

- \* Bend a lock tab against a ring nut flat.
- \* Always use a new cotter pin on the axle nut.

2. Adjust the rear brake. See "Brake Adjustment" on page 2-8.

### TIGHTENING TORQUE:

Ring Nut:

100 Nm (10.0 m·kg, 72 ft·lb)

Rear Axle Nut:

65 Nm (6.5 m·kg, 47 ft·lb)

Rear Wheel Panel:

28 N m (2.8 m·kg, 20 ft·lb)

Rear Brake Lever:

9 Nm (0.9 m·kg, 6.5 ft·lb)

# SHAFT DRIVE AND REAR WHEEL BEARINGS

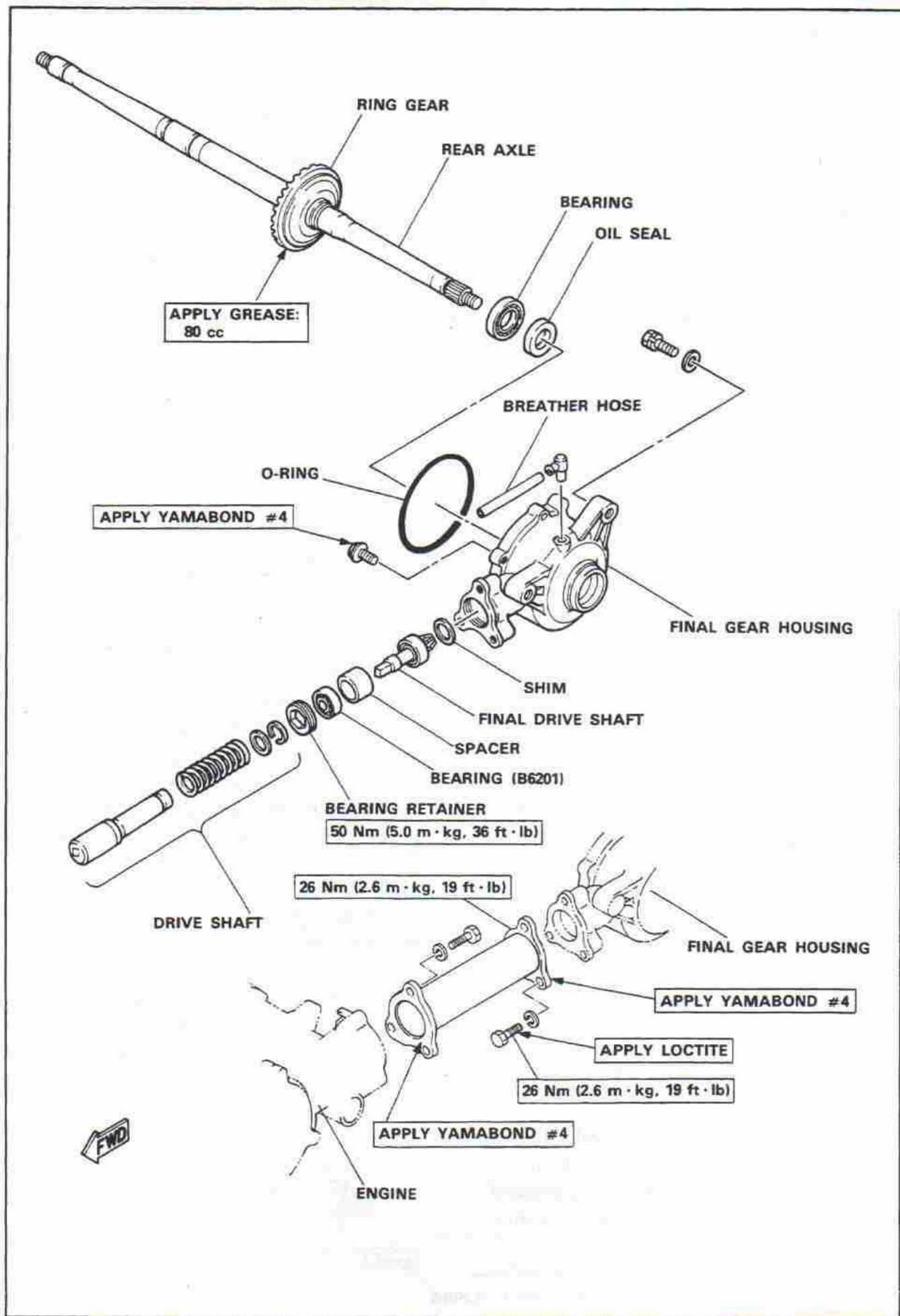

## Troubleshooting

The following conditions may indicate damaged shaft drive components:

Symptoms	Possible damaged areas
<ol style="list-style-type: none"><li>1. A pronounced hesitation or "jerky" movement during acceleration, deceleration, or sustained speed. (This must not be confused with engine surging)</li><li>2. A "rolling rumble" noticeable at low speed; a high-pitched whine; a "clunk" from a shaft drive component or area.</li></ol>	<ol style="list-style-type: none"><li>A. Damage to bearings.</li><li>B. Improper gear lash.</li><li>C. Gear tooth damage.</li></ol>
<ol style="list-style-type: none"><li>3. A locked-up condition of the shaft drive mechanism; no power transmitted from engine to rear wheel.</li></ol>	<ol style="list-style-type: none"><li>D. Broken drive shaft.</li><li>E. Broken gear teeth.</li><li>F. Seizure due to lack of lubrication.</li><li>G. Small foreign object lodged between moving parts.</li></ol>

### NOTE:

Damaged areas A, B, and C above may be extremely difficult to diagnose. The symptoms are quite subtle and difficult to distinguish from normal machine operating noise. If there is reason to believe these components are damaged, remove the components for specific inspection.

### Inspection notes:

1. During coasting, accelerating, or decelerating, the "rolling rumble" will increase with rear wheel speed, not engine speeds. However, such noise may also be due to damaged wheel bearings.
2. Noise that varies with acceleration and deceleration: following incorrect reassembly, a condition of too-little gear lash may produce a whine during deceleration.

3. A slight "thunk" must be distinguished from normal machine operation. It will be most noticeable at low speed and could indicate broken gear teeth.

### CAUTION:

Too-little gear lash is extremely destructive to the gear teeth. If a test ride following reassembly indicates this condition, stop riding immediately to minimize damage to the gears.

### WARNING:

If broken gear teeth are suspected, stop riding immediately. This condition could lead to locking-up of the shaft drive assembly and result in harm to a rider.

#### 4. Troubleshooting chart

Where basic conditions "1" and "2" above exist, consider the following chart:

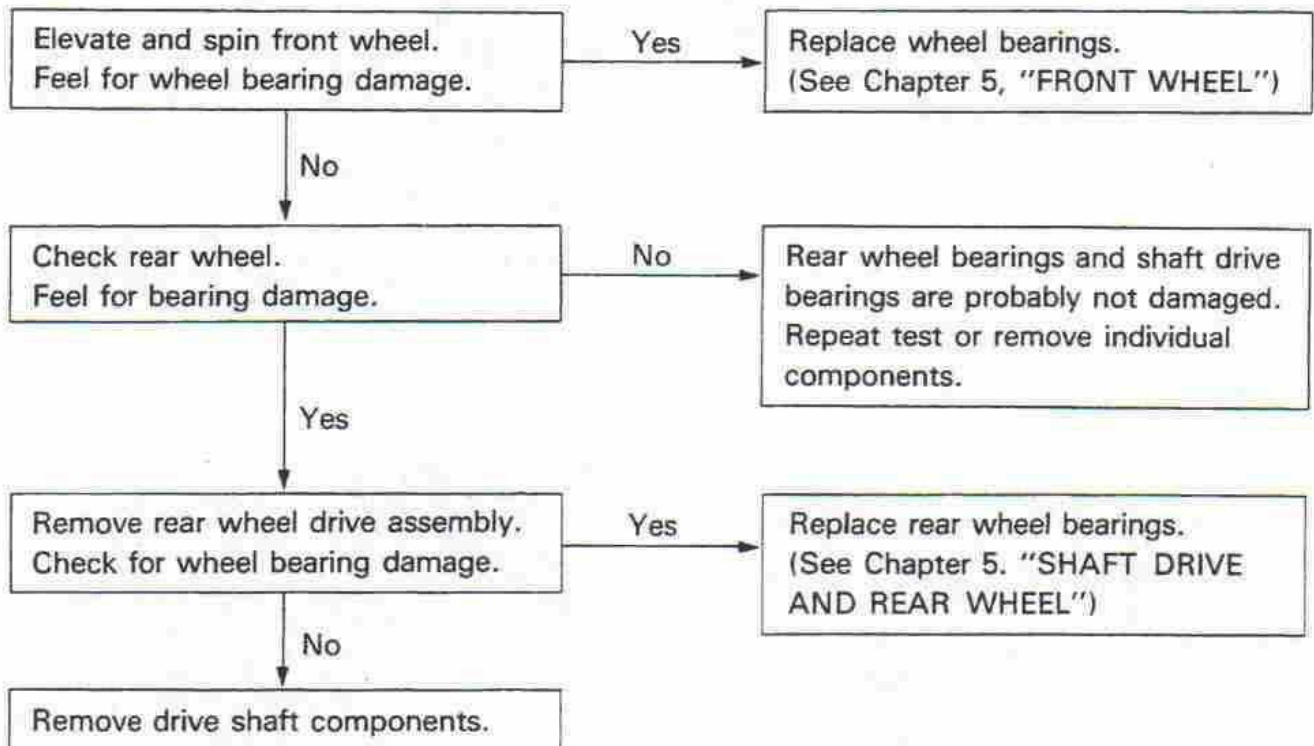

#### 5. Grease leak inspection

If a shaft drive component is suspected of leaking grease, first thoroughly clean the entire machine. The apparent location of a grease leak on a dusty machine may be misleading. Dry the machine and apply a leak-localizing compound or a dry-powder spray that will limit the flow of any leaking grease. Operate the machine prepared in this way for the distance neces-

sary to locate precisely the leak. There is the possibility that a component housing may have been damaged by road debris or an accident, or an O-ring or an oil seal may be cracked or broken. However, on a new or nearly new machine, an apparent grease leak may be the result of a rest-preventive coating or excessive assembly lubrication of the seals. Always clean the machine and recheck the suspected location of any apparent leakage.

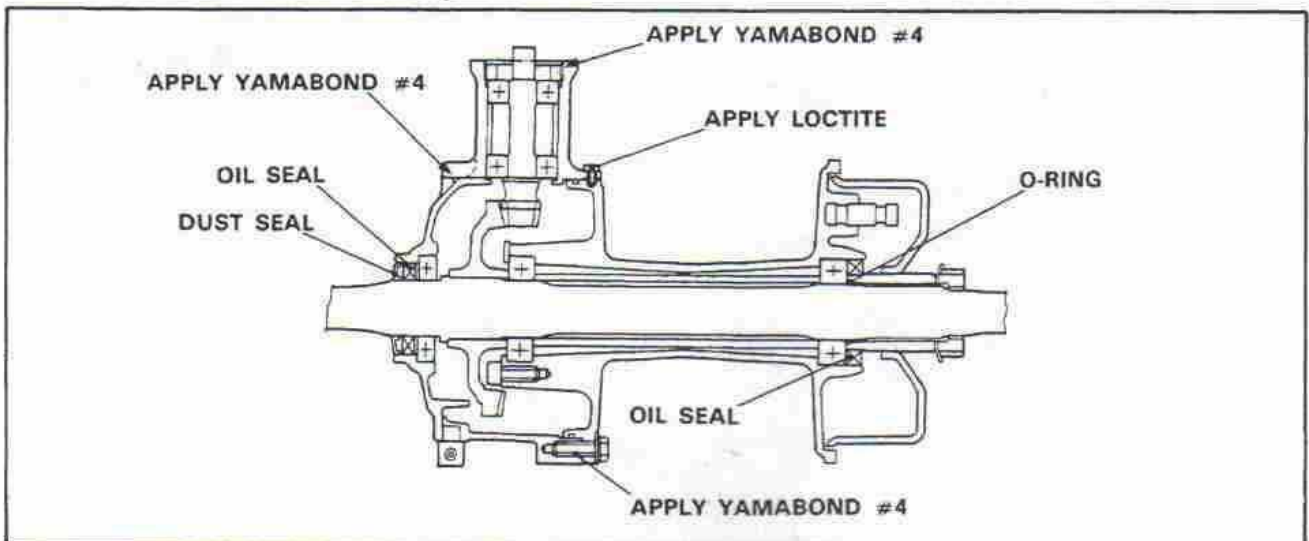

## Removal

If the bearings allow play in the wheel hub or if the wheel does not turn smoothly, remove the rear wheel drive assembly as follows:

1. Block the front tire and jack up the rear of the machine. Apply the parking brake.
2. Remove the rear wheels, axle nuts, and rear wheel flanges from the rear axle.
3. Remove the rear axle ring nut: Use with the ring nut wrench.
4. Release the parking brake, and disconnect the rear brake calbe from the brake lever.
5. Remove the rear brake cover and brake shoe assembly.
6. Remove the drive shaft housing securing bolts from the engine.



7. Remove the final gear breather pipe, rear wheel housing and final gear housing securing bolts. Remove the rear wheel drive assembly and drive shaft.
8. Remove the drive-shaft-housing-securing bolts and housing.
9. Remove the bolts securing the bearing housing. Remove the rear wheel housing from the final gear housing by using the two screwdrivers.

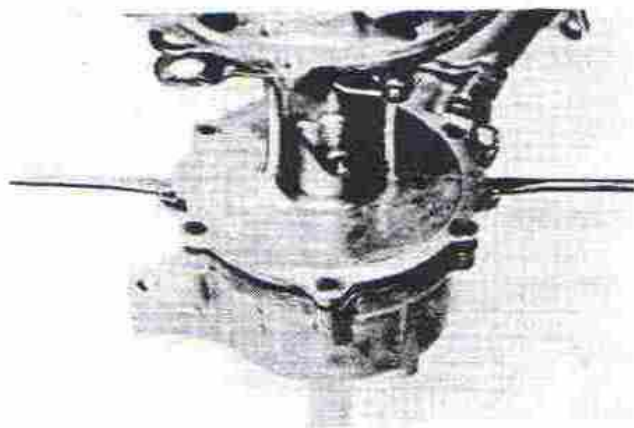

10. Remove the final-drive-shaft-bearing retainer with the Hexagon Wrench (22 mm).

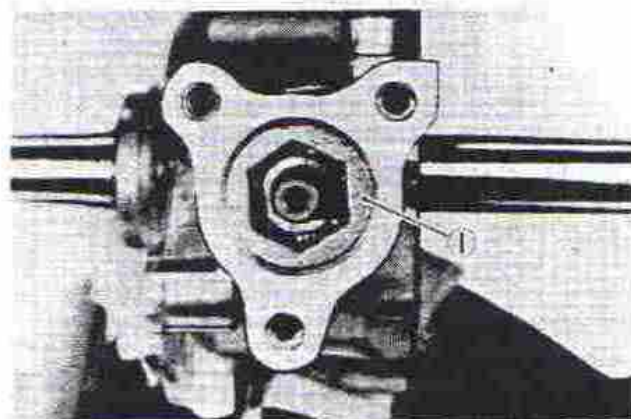

1. Bearing retainer

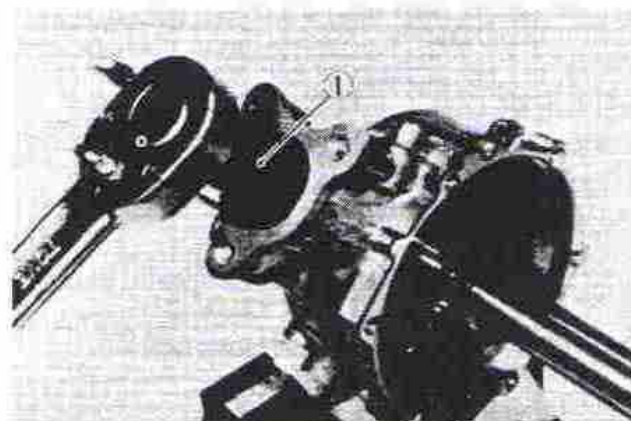

1. Hexagon Wrench (22 mm)

11. Remove the final drive shaft assembly from the final gear case.

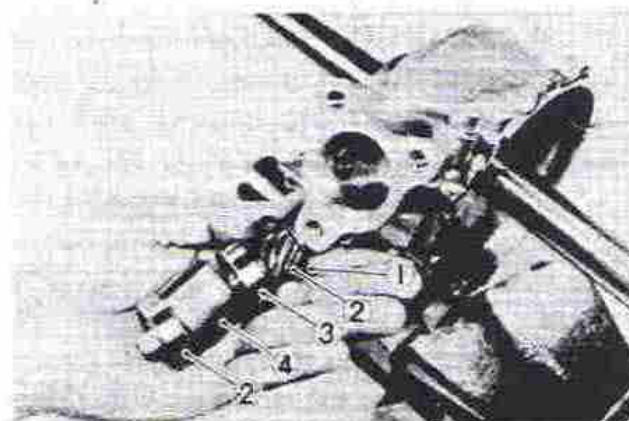

1. Shim  
2. Drive pinion gear

3. Bearing  
4. Collar

- Remove the ring gear/rear axle assembly from the case.

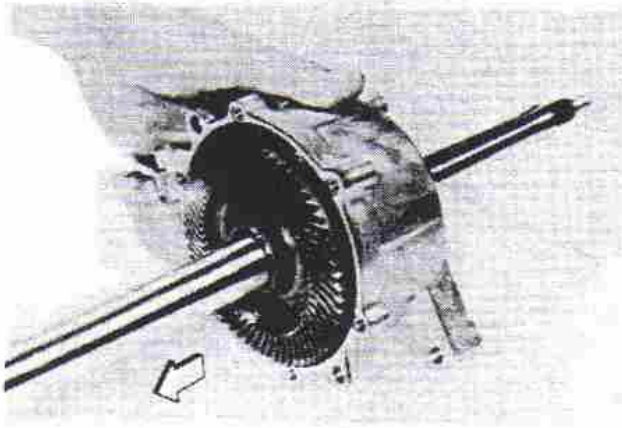

### Inspection

#### Rear Axle

- As shown below, support the rear axle by placing V-blocks under the bearing mounting positions and check for the rear axle at both ends.

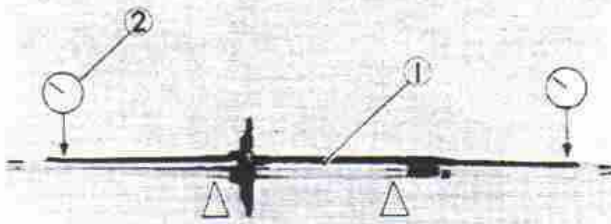

1. Rear axle 2. Dial gauge

Rear Axle Runout Limit:  
1.5 mm (0.06 in)

- If the runout exceeds 1.5 mm (0.06 in), replace the rear axle with a new one.

#### Gears

- Inspect the gear teeth on all the gears. If discoloration, galling, pitting, or excessive wear is found on any gear, replace all the final gears as a set.

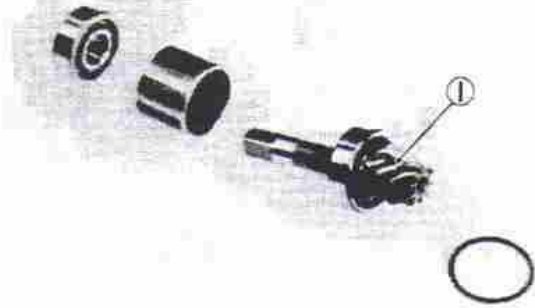

- Drive pinion gear
- Measure the deflection of ring gear complete using a dial gauge.

Deflection Limit: 0.08 mm (0.0031 in)

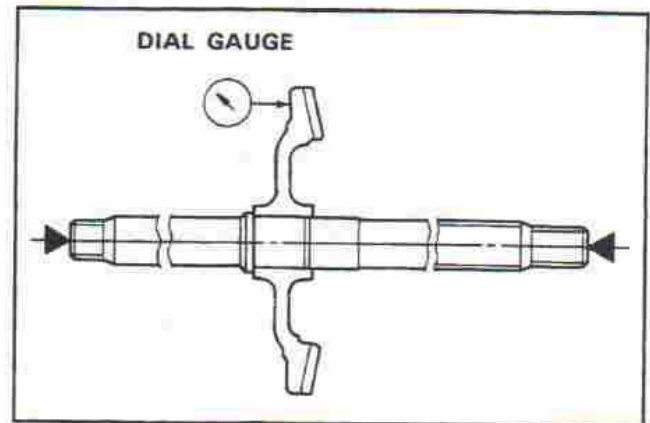

#### Bearings and Oil Seals

- Put your finger on the bearing race, and check the bearing movement. If any bearing is rough, replace it.

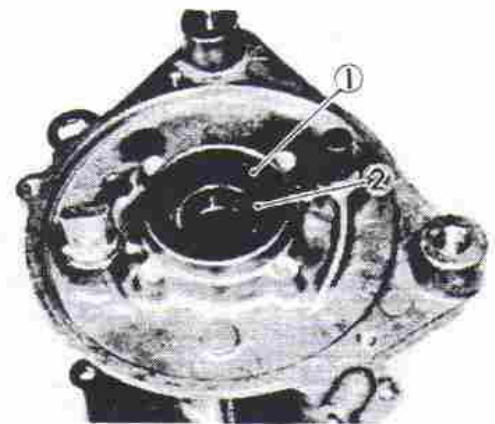

1. Oil seal 2. Bearing

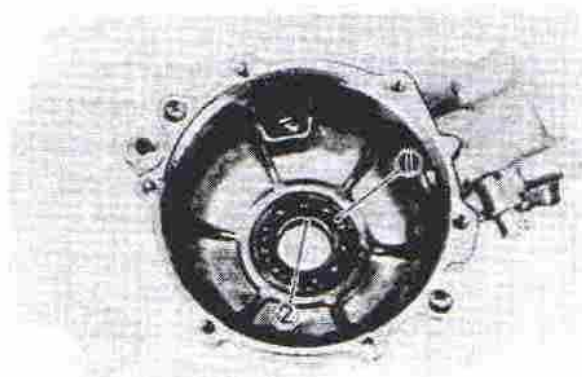

1. Bearing 2. Oil seal

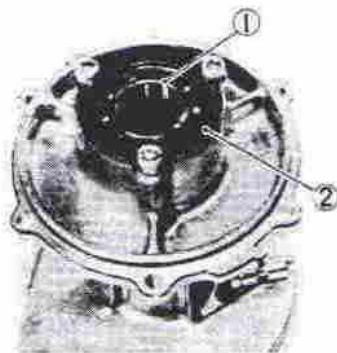

1. Bearing 2. Bearing retainer

2. Drive the bearings and oil seals out by tapping around the perimeter of the bearing inner race with a soft metal drift punch and hammer.

**WARNING:**

Eye protection is recommended when using the striking tools.

**TIGHTENING TORQUE:**

Bearing Retainer:  
12 Nm (1.2 m·kg, 8.7 ft·lb)

**Assembly**

1. Install the rear axle/ring gear assembly into the final gear housing.

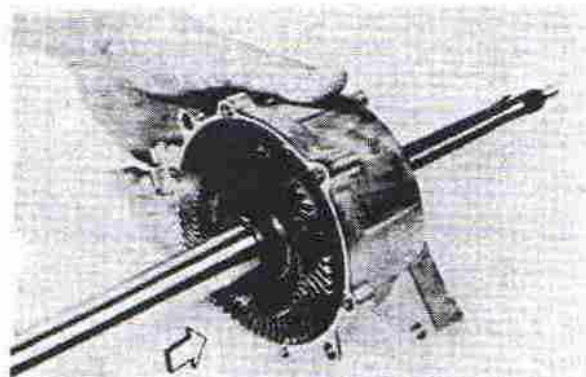

2. Install the drive pinion gear assembly with the original shim into the housing.

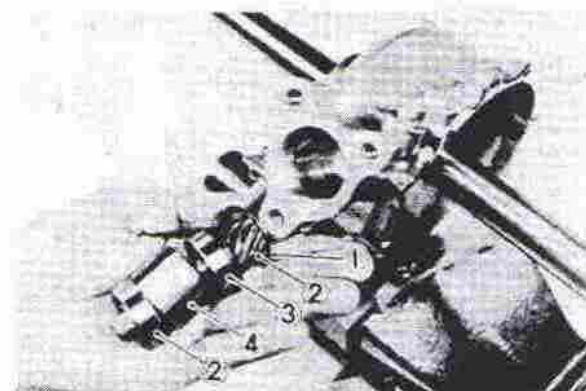

1. Shim 3. Bearing  
2. Drive pinion gear 4. Collar

3. Install the bearing retaining nut, and torque the nut to specification. Use the Hexagon Wrench.

**TIGHTENING TORQUE:**

50 Nm (5.0 m·kg, 36 ft·lb)

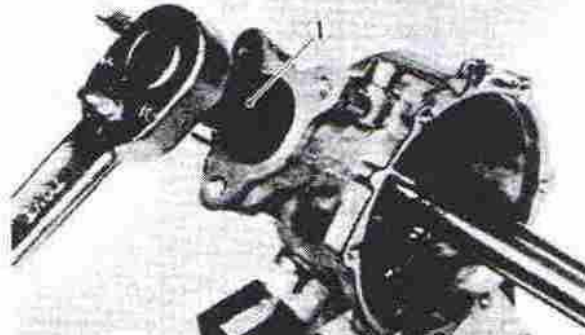

1. Hexagon Wrench (22 mm)

4. Apply grease to the drive pinion and ring gears.

**Recommended Lubricant:**

Lithium base wheel bearing grease  
(EX. SHELL LETHINAX A)

Grease Quantity: 10 g (0.4 oz)

Lubrication Intervals:

Every 2 years

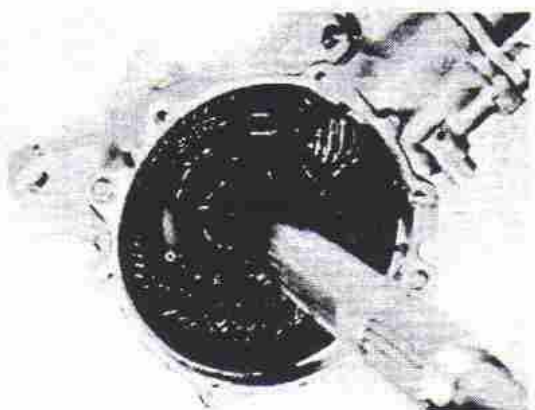
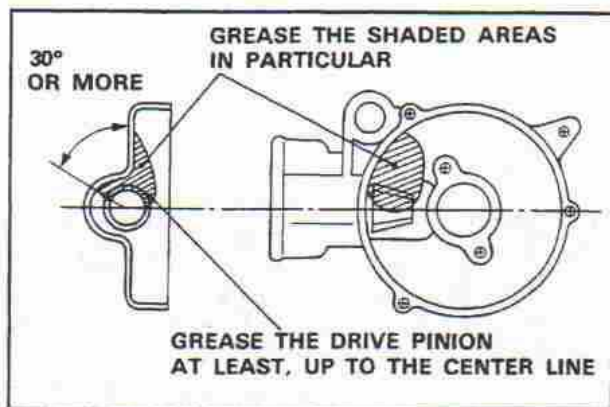

5. Install the rear wheel housing onto the final gear housing. Apply Yamabond #4<sup>®</sup> to all bolt threads, and torque the bolts to specification.

**TIGHTENING TORQUE:**

10 Nm (1.0 m · kg, 7.2 ft · lb)

6. Install the drive shaft housing. Apply Yamabond #4<sup>®</sup> to the contact surfaces of drive shaft housing and final gear housing. Apply LOCTITE<sup>®</sup> to the bolt threads, and torque the bolts to specification.

**TIGHTENING TORQUE:**

26 Nm (2.6 m · kg, 19 ft · lb)

7. Apply grease to the square recesses of the drive shaft, and install the drive shaft into the drive shaft housing. The drive shaft spring faces toward the rear.

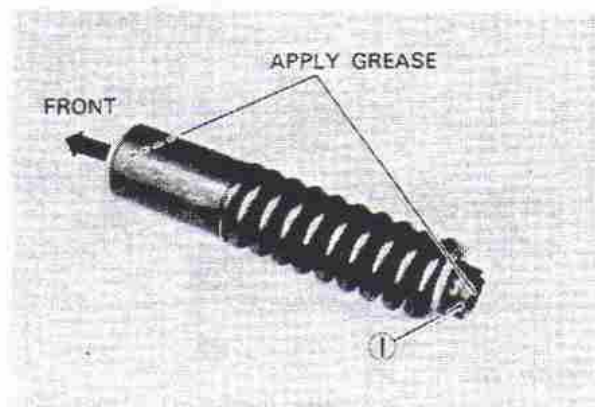

1. Drive shaft

8. Install the rear wheel drive assembly. Torque the bolts to specification.

**NOTE:**

- Apply Yamabond #4<sup>®</sup> to the threads of final gear housing securing bolts (Front-side only).
- Apply Yamabond #4<sup>®</sup> to the contact surfaces of drive shaft housing and engine.

**TIGHTENING TORQUE:**

Final Gear Housing & Frame:

50 Nm (5.0 m · kg, 36 ft · lb)

Rear Wheel Housing & Frame:

50 Nm (5.0 m · kg, 36 ft · lb)

Drive Shaft Housing & Engine:

26 Nm (2.6 m · kg, 19 ft · lb)

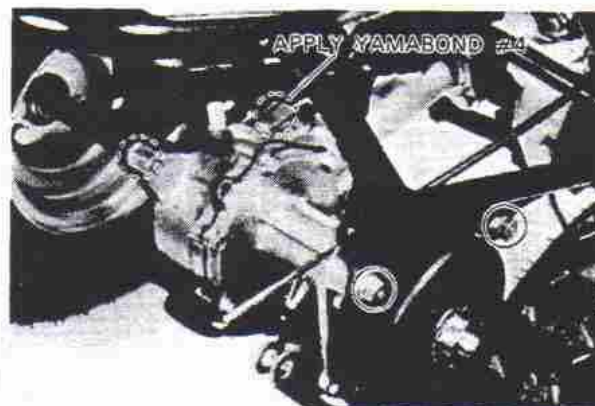

9. To assemble the rear brake and rear wheels, reverse the disassembly procedures. See "Rear Brake" on page 5-3.



## DRIVE SHAFT

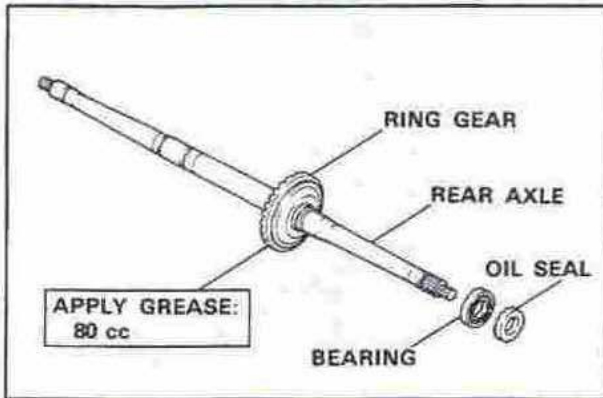

### Removal

1. Remove the rear wheel drive assembly. See "SHAFT DRIVE AND REAR WHEEL BEARING" in this chapter.

### Inspection

1. Inspect the square recesses for wear and/or damage. If wear is excessive, replace the drive shaft.

### NOTE:

When installing the drive shaft, lubricate the square recesses with molybdenum disulfide grease.

### Assembly

1. When installing the drive shaft, reverse the removal procedure. Note the following points:
  - \* Lubricate the shaft drive square recesses with molybdenum disulfide grease.
  - \* Apply Yamabond #4<sup>®</sup> to the contact surfaces of drive shaft housing and engine.
  - \* The drive shaft spring face should be toward the rear side.
  - \* Torque the drive shaft housing, final gear case, and rear wheel housing bolts to specification.

### TIGHTENING TORQUE:

- Final Gear Housing & Frame:  
50 Nm (5.0 m·kg, 36 ft·lb)
- Rear Wheel Housing & Frame:  
50 Nm (5.0 m·kg, 36 ft·lb)
- Drive Shaft Housing & Engine:  
26 Nm (2.6 m·kg, 19 ft·lb)

- \* Apply Yamabond #4<sup>®</sup> to threads of final gear housing securing bolt (Front-side only).

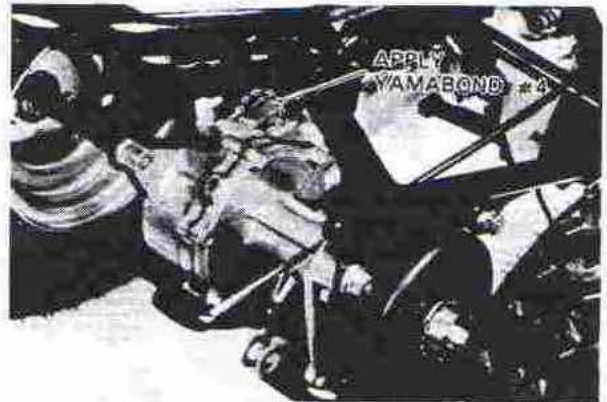

# FRONT FORKS AND STEERING HEAD

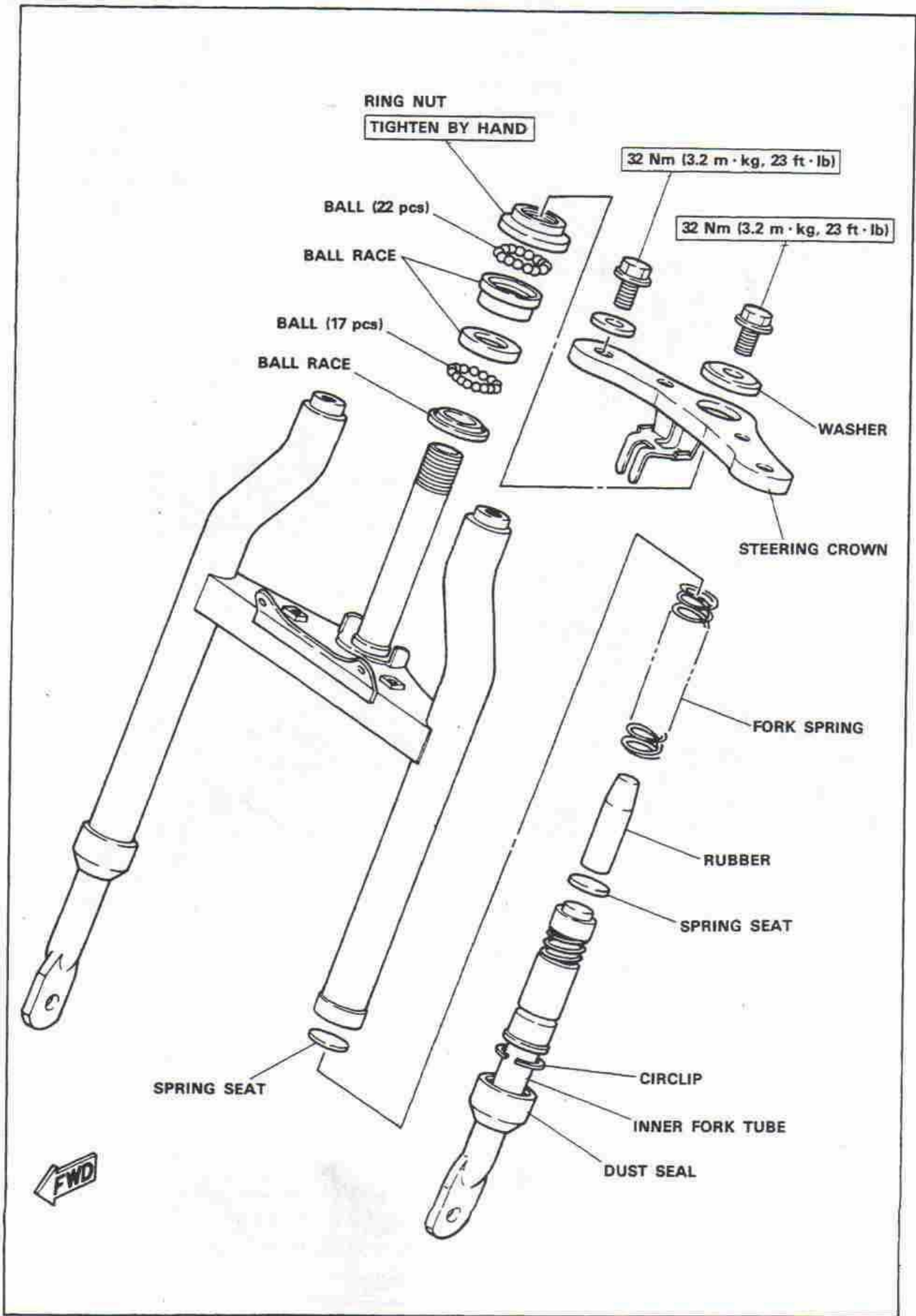

## Removal and Disassembly

1. Raise the front wheel by placing the suitable stand under each footrest.
2. Remove the front wheel and front fender.
3. Remove the starter (Choke) lever and handlebars securing nuts, and remove the handlebars.

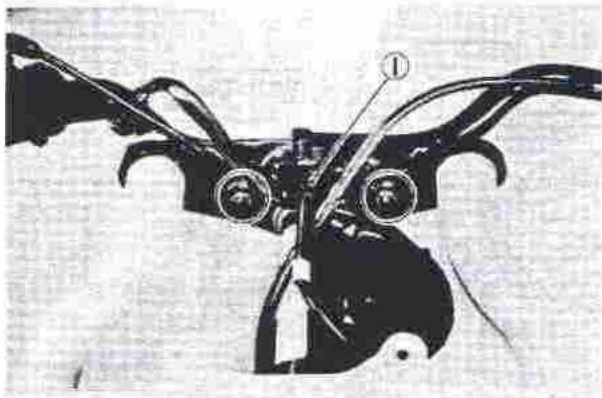

1. Starter lever

4. Remove the fork and steering crown securing bolts.

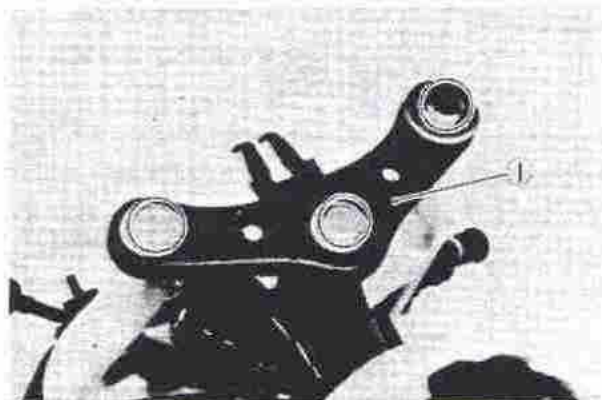

1. Steering crown

5. Support the forks, and remove the steering stem ring nut and fork assembly.

### NOTE:

Be careful not to drop the ball.

#### Ball Quantity:

Upper: 26 pcs (5/32)

Lower: 22 pcs (3/16)

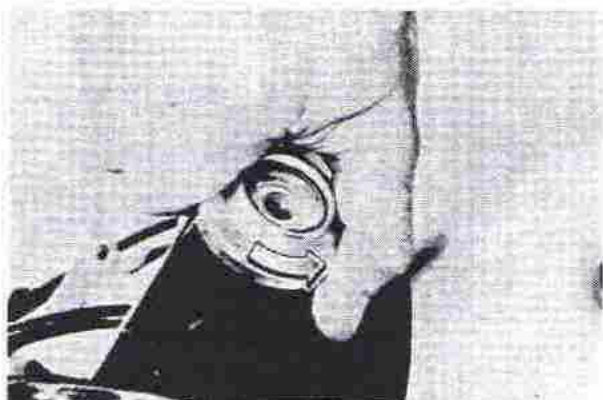
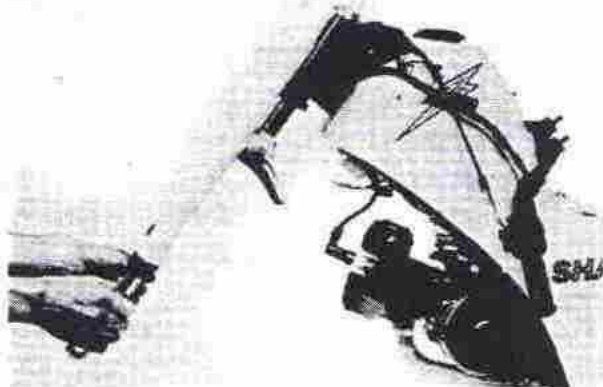

6. Remove the dust seal and guide bush retainer clip. Remove all part from the outer fork tube.

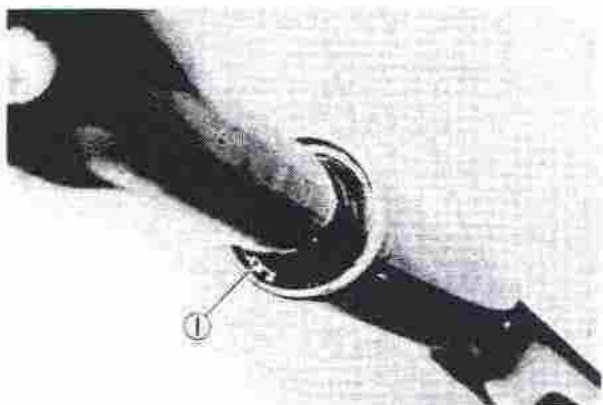

1. Circlip

### Inspection

#### Front Forks

1. Examine the inner fork tube. If the tube is severely scratched or bent, it should be replaced.

### WARNING:

Do not attempt to straighten a bent fork tube; this may dangerously weaken the tube.

2. Check the outer fork tubes for dents. Replace the tube if it is dented.
3. Check the free length of the springs.

Fork Spring Free Length Limit:  
110 mm (4.33 in)

### Steering Head

1. Wash the bearings in solvent.
2. Inspect the bearings for pitting or other damage. Replace the bearings if pitted or damaged. Replace the races when the balls are replaced.
3. Clean and inspect the bearing races. Spin the bearings by hand. If the bearings are not smooth in their operation, replace balls and races.



### Assembly

1. Make sure all components are clean before assembly.
2. Apply grease to the inner fork tube assembly.

Recommended Lubricant:  
Lithium base wheel grease

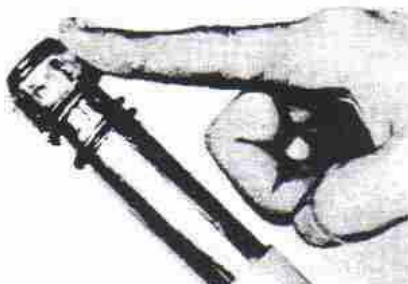

3. Install the all components into the outer fork tube as shown.

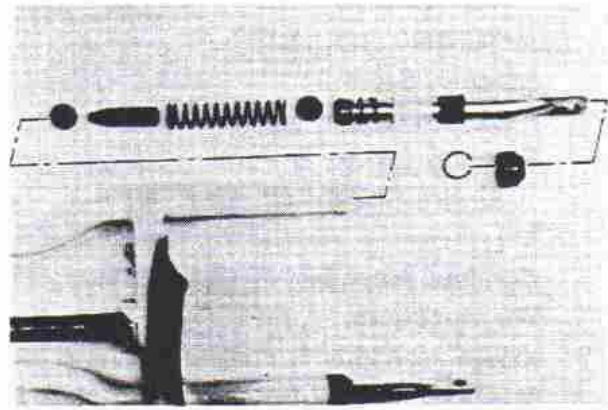

4. Install the guide bush retainer clip and dust seal.

### CAUTION:

Make sure the retainer clip is correctly fitted in the groove of the outer fork tube.

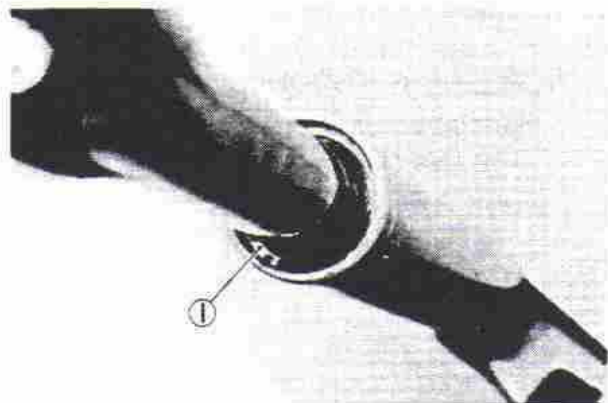

1. Clip

5. Grease the bearings and races with wheel bearing grease.

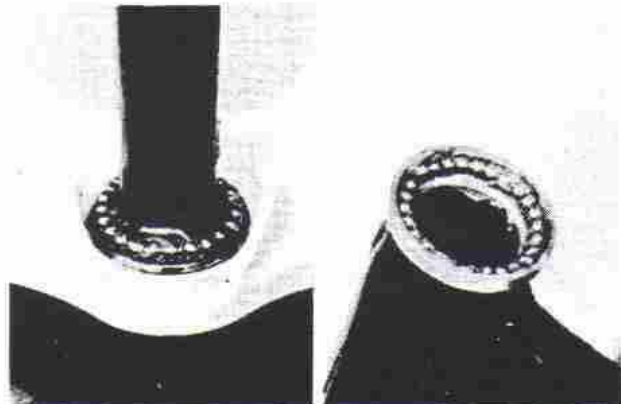

6. Install the steering stem, balls, and tighten the ring nut by your hand.

7. Install the steering crown, and tighten the bolts to specification.

**TIGHTENING TORQUE:**

Steering Stem:

32 Nm (3.2 m · kg, 23 ft · lb)

Steering Crown &amp; Fork:

32 Nm (3.2 m · kg, 23 ft · lb)

8. Continue assembly; reverse the disassembly procedure.
9. When assembly is complete, check the steering stem by turning it from lock to lock. If there is any binding or looseness, readjust the tightness of the steering stem.

**WARNING:**

Always use a new cotter pin on the axle nut.

**TIGHTENING TORQUE:**

Handlebars &amp; Steering Crown:

19 Nm (1.9 m · kg, 13 ft · lb)

Front Axle:

50 Nm (5.0 m · kg, 36 ft · lb)

## CABLES AND FITTINGS

### Cable Maintenance

**NOTE:**

See Maintenance and Lubrication Interval Charts for additional information.

Cable maintenance is primarily concerned with preventing deterioration through rust and weathering; and assuring that the cable moves freely within its housing.

Cable removal is straightforward and uncomplicated. Removal will not be discussed within this section. For details, see the individual maintenance section for which the cable is an integral part.

Cable routing is very important however. For details of cable routing, see the cable routing diagrams at the end of this manual.

1. Remove the cable.
2. Check for free movement of cable within its housing. If movement is obstructed, check for fraying or kinking of the cable strands. If damage is evident, replace the cable assembly.
3. To lubricate cable, hold in a vertical position. Apply lubricant to uppermost end of cable. Leave in a vertical position until lubricant appears at bottom end. Allow excess to drain and re-install.

**NOTE:**

Choice of lubricant depends upon conditions and preference. However, a semi-drying chain and cable lubricant will probably perform adequately under most conditions.

# CHAPTER 6 ELECTRICAL

YT60L WIRING DIAGRAM .....	6-1
<b>IGNITION SYSTEM .....</b>	<b>6-2</b>
Operation .....	6-3
Engine Speed Control Unit Troubleshooting .....	6-4
Ignition System Troubleshooting .....	6-4
Ignition Spark Gap Test .....	6-5
Pickup Coil Inspection .....	6-5
Charge Coil Inspection .....	6-6
Spark Plug .....	6-6

# CHAPTER 6 ELECTICAL

## YT60L WIRING DIAGRAM

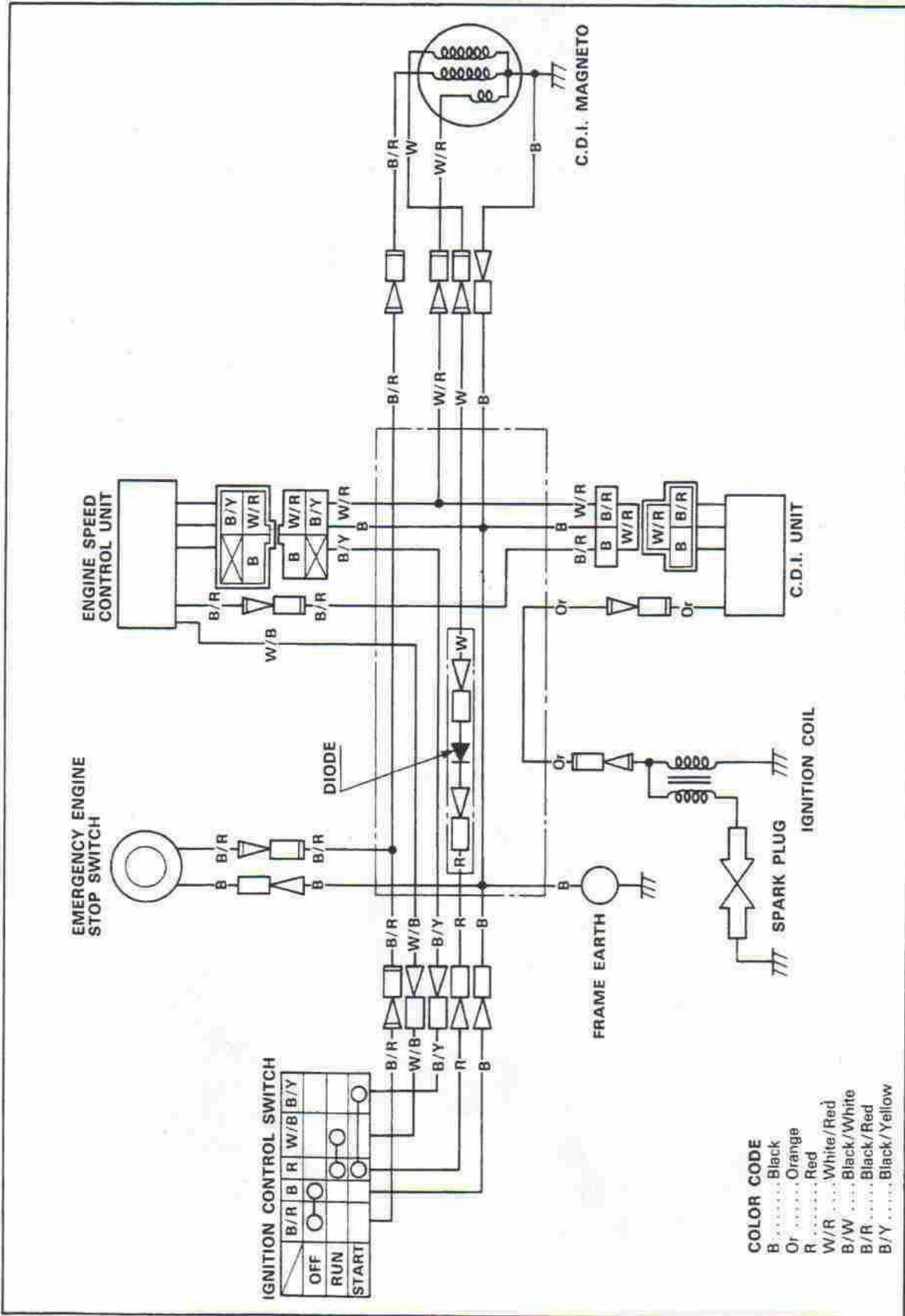

# IGNITION SYSTEM

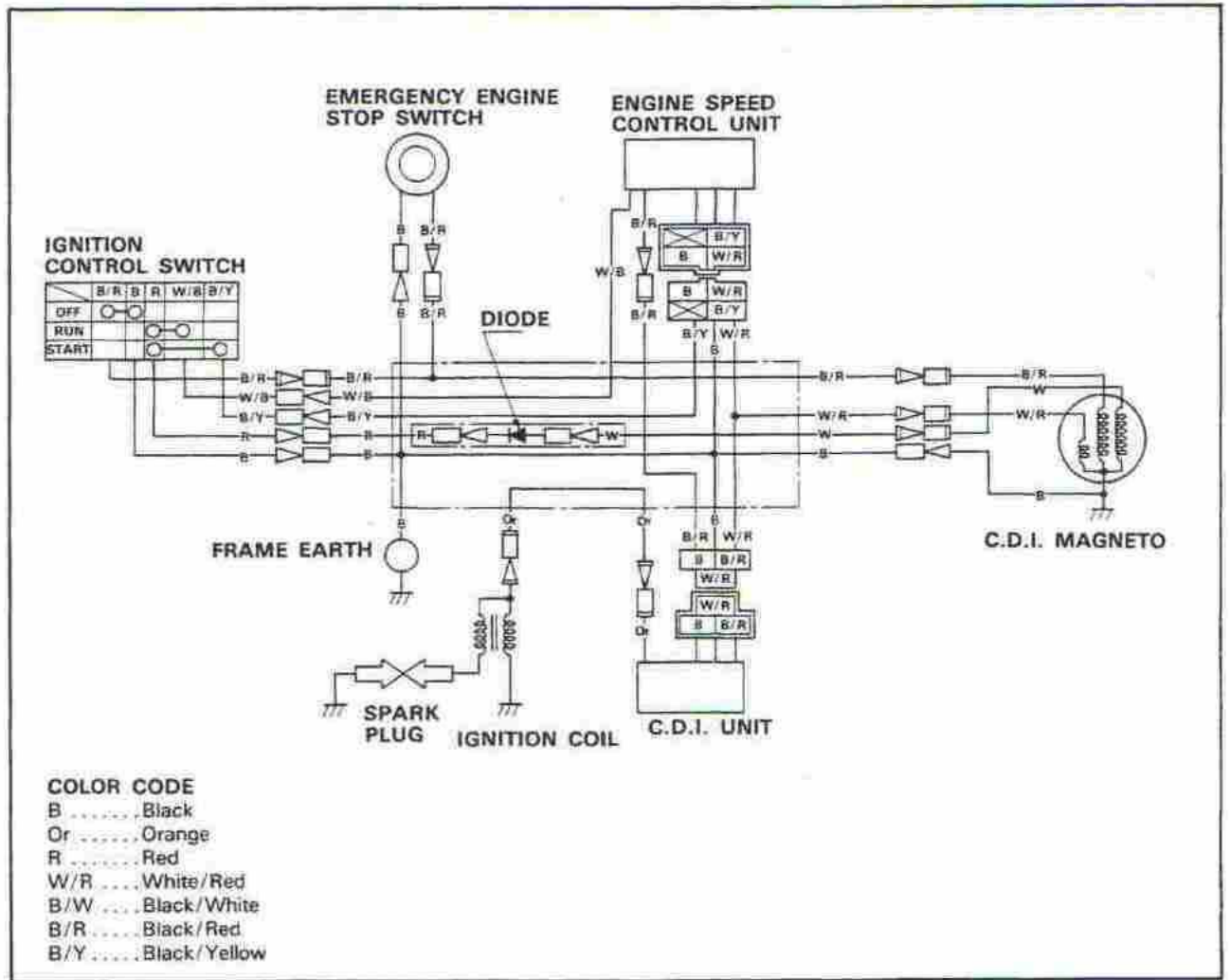



## Operation

WHEN THE IGNITION CONTROL SWITCH IS AT "START" AND RECOIL STARTER IS PULLED:

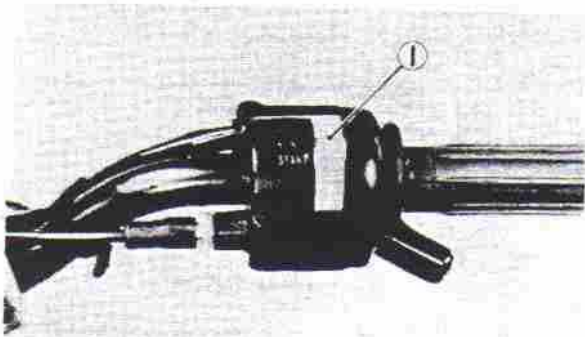

1. Ignition control switch

The flywheel magneto turns and the charge coil generates a voltage which is stored in the condenser in the C.D.I. unit. When a trigger voltage from the pickup coil turns on the SCR 1 (Silicon controlled rectifier), the electricity stored in the condenser is discharged to the primary winding of the ignition coil. This induces a high voltage surge in the secondary winding and produces a spark across the spark plug gap; thus, the engine can be started.

If the throttle grip is opened, the engine speed will increase slowly. But the engine speed reaches  $2,300 \pm 200$  r/min, a trigger voltage from the pickup coil flows to the engine speed control unit to turn on the ZN (zener diode) which turns on the SCR 2.

As a result, the voltage from the charge coil is grounded and not supplied to the C.D.I. unit; thus, no spark is produced at the spark plug and the engine speed is decreased but the engine keeps on running by utilizing the C.D.I. circuit.

WHEN THE IGNITION CONTROL SWITCH IS MOVED FROM "START TO RUN":

The engine speed control unit will not function, and the engine operates through the C.D.I. circuit. The engine speed will increase in response to the throttle opening so that you can start off.

IF THE RECOIL STARTER IS PULLED WITH THE IGNITION CONTROL SWITCH AT "RUN":

The SCR 2 in the engine speed control unit turns on, and the voltage generated by the charge coil flows through SCR 2 to ground. This means that no spark is produced and thus the engine will not start.

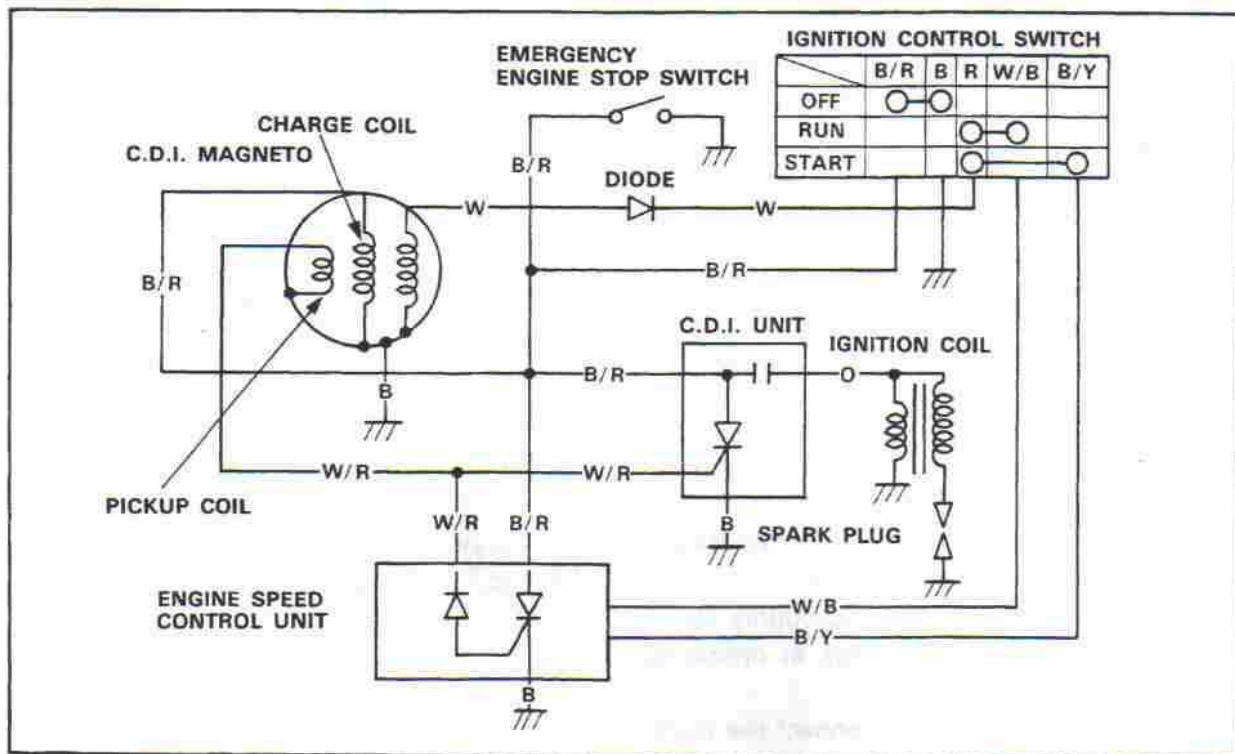

## Engine Speed Control Unit Troubleshooting

1. First, check the coupler and leads for connection.
2. Check the resistance of the charging coil windings with the pocket tester. If the resistance is not within specification, replace the charging coil assembly.

Charging Coil Resistance:  
 $0.63\Omega \pm 10\%$  at  $20^{\circ}\text{C}$  ( $68^{\circ}\text{F}$ )  
 (White - Black)

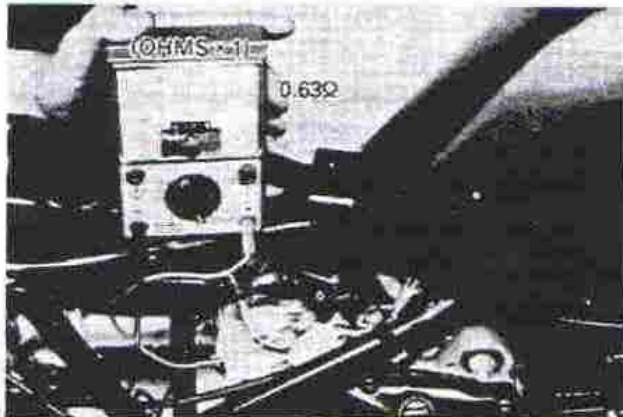

3. Check the ignition control switch for continuity with a pocket tester.

Switch position	Wire color				
	B/R	B	R	W/B	B/Y
OFF	○ — ○				
RUN			○ — ○		
START			○ — ○		○

4. If the engine revolutions are not controlled at  $2,300 \pm 200$  r/min, replace the control unit assembly.

## Ignition System Troubleshooting

The entire ignition system can be checked for misfire and weak spark by using the Electro Tester. If the ignition system will fire across a specified gap, the engine ignition system is good. If it will not fire across the gap, proceed with the individual component tests until the source of the problem is located.

1. Warm up the engine thoroughly so all electrical components are at operating temperature.
2. Stop the engine, and connect the tester as shown.

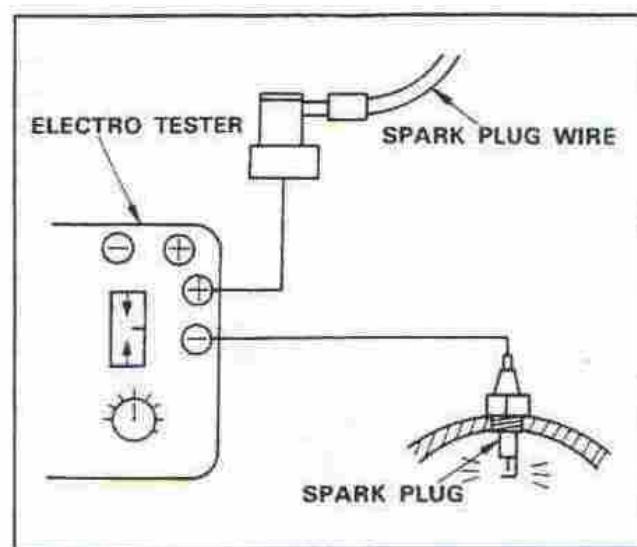

3. Start the engine, and increase the spark gap until misfire occurs. (Test at various rpm between idle and red line.)

Minimum Spark Gap: 6 mm (0.24 in)

If the ignition system becomes inoperative or if the engine misfires at the minimum spark gap or at a smaller gap, there is a problem in the ignition system. Follow the troubleshooting chart until the source of the problem is located.

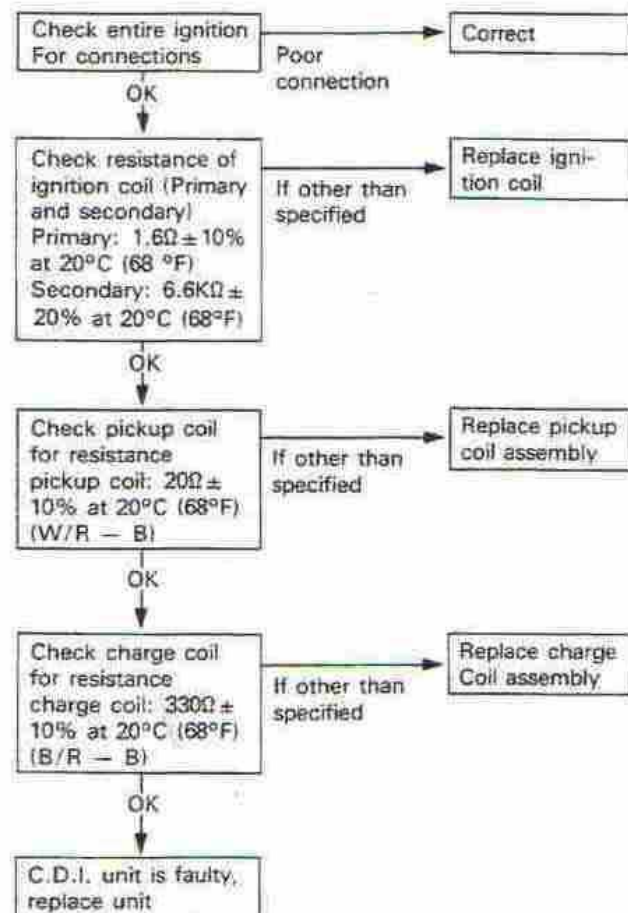

## Ignition Spark Gap Test

1. Remove the engine-mounting-bracket cover from the front cylinder, and disconnect the ignition coil wires from the wiring harness and from the spark plugs.
2. Connect the Electro Tester as shown.

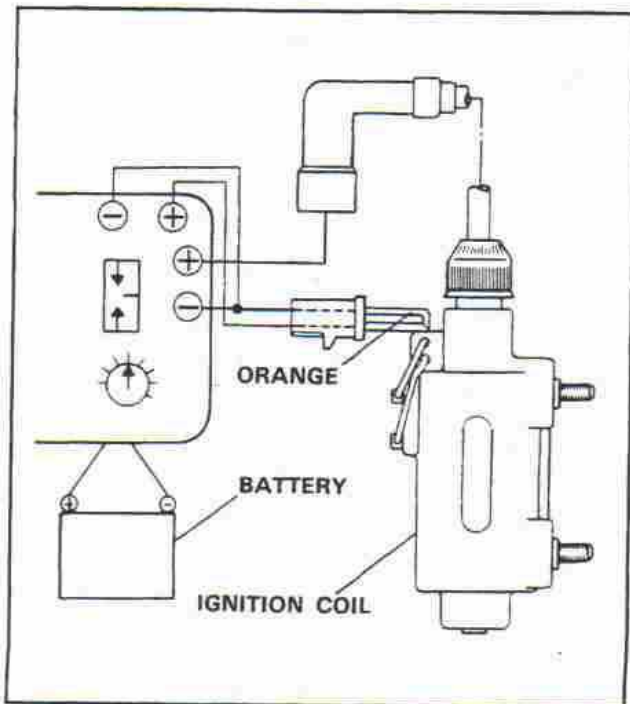

3. Connect a fully charged battery to the tester.
4. Turn on the spark gap switch, and increase the gap to maximum unless misfire occurs first.

Minimum Spark Gap: 6 mm (0.24 in)

## Direct Current Resistance Test

Use the pocket tester to determine resistance and continuity of primary and secondary coil windings.

Standard Value:

Primary Coil Resistance:

$1.6 \Omega \pm 10\%$  at  $20^{\circ}\text{C}$  ( $68^{\circ}\text{F}$ )

Secondary Coil Resistance:

$6.6 \text{ K}\Omega \pm 10\%$  at  $20^{\circ}\text{C}$  ( $68^{\circ}\text{F}$ )

## PRIMARY COIL CHECK

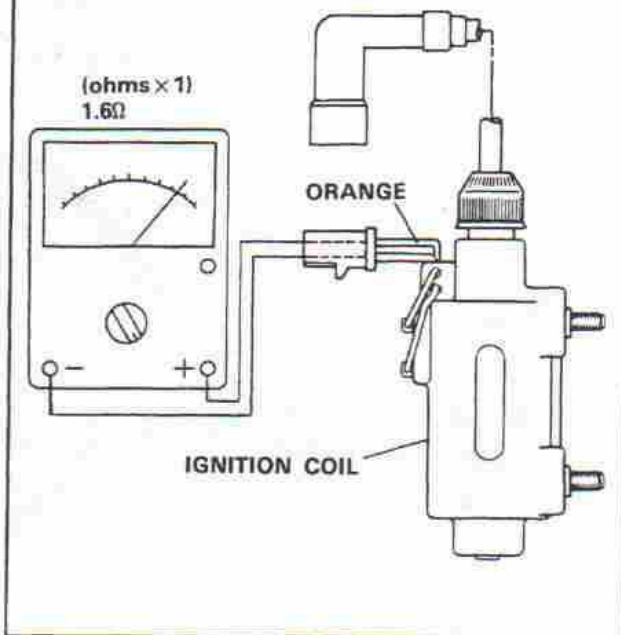

## SECONDARY COIL CHECK

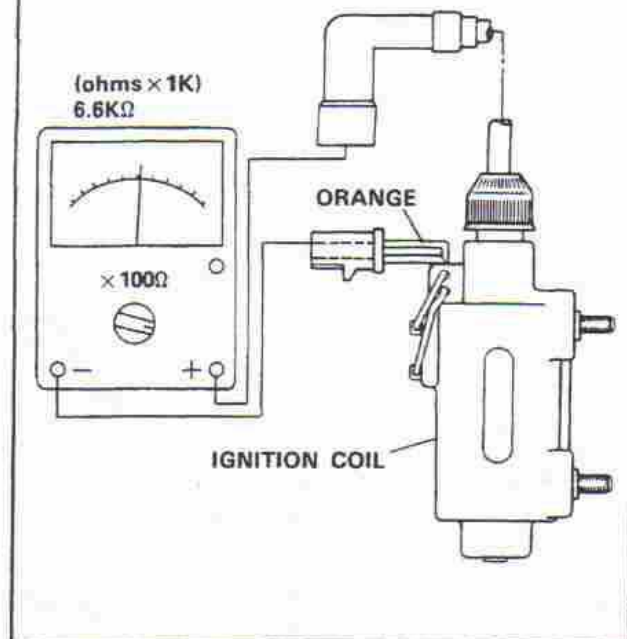

## Pickup Coil Inspection

1. Remove the body cowling assembly.
2. Disconnect the C.D.I. magneto leads.
3. Check the resistance of the pickup coil windings with the pocket tester. If the resistance is not within specification, replace the pickup coil assembly.

Pickup Coil Resistance:  
 $20\Omega \pm 10\%$  at  $20^{\circ}\text{C}$  ( $68^{\circ}\text{F}$ )  
(White/Red — Black)

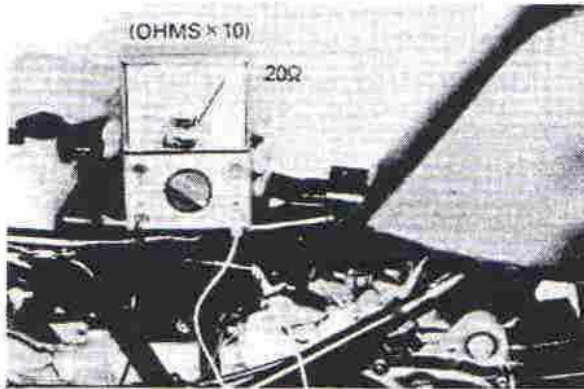

#### Charge Coil Inspection

1. Check the resistance of the charge coil windings with pocket tester. If the resistance is not within specification, replace the pickup coil assembly.

Charge Coil Resistance:  
 $330\Omega \pm 10\%$  at  $20^{\circ}\text{C}$  ( $68^{\circ}\text{F}$ )  
(Brown/Red — Black)

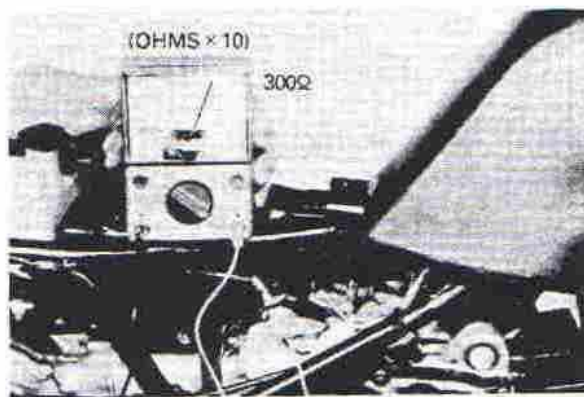

#### Spark Plug

The life of a spark plug and its discoloring vary according to the habits of the rider. At each periodic inspection, replace burned or fouled plugs with new ones of the specified type. It is actually economical to install new plugs often since it will tend to keep the engine in good condition and prevent excessive fuel consumption.

1. Inspect and clean the spark plug, and replace it as required.
2. Clean the electrodes of carbon, and adjust the electrode gap to the specification. Be sure to use the proper reach, type, and electrode gap plug as a replacement to avoid overheating, fouling, or piston damage.

Type:

BP6HS (NGK) or W20FP-U (ND)

Electrode Gap:

0.6–0.7 mm (0.024–0.028 in)

TIGHTENING TORQUE:

20 Nm (2.0 m·kg, 14 ft·lb)

# CHAPTER 7 APPENDICES

SPECIFICATIONS .....	7-1
GENERAL TORQUE SPECIFICATIONS .....	7-8
DEFINITION OF UNITS .....	7-8
CONVERSION TABLES .....	7-9
EXPLODED DIAGRAMS .....	7-10
LEFT-SIDE CRANKCASE .....	7-10
PRIMARY GEAS/CLUTCH .....	7-11
FORK/STEERING HEAD .....	7-12
FRONT TIRE .....	7-13
REAR WHEEL HUB .....	7-14
FINAL GEAR .....	7-15
ELECTRICAL COMPONENTS .....	7-16
CABLE ROUTING .....	7-17
YT60L WIRING DIAGRAM .....	7-20

# CHAPTER 7 APPENDICES

## SPECIFICATIONS

### I. GENERAL SPECIFICATIONS

Model	YT60L
Model Code Number	36R
Frame Starting Number	36R-000101
Engine Starting Number	36R-000101
Dimensions:	
Overall Length	1,300 mm (51.2 in)
Overall Width	755 mm (29.7 in)
Overall Height	720 mm (28.3 in)
Seat Height	490 mm (19.3 in)
Wheelbase	860 mm (33.9 in)
Minimum Ground Clearance	110 mm ( 4.0 in)
Tire Tread	590 mm (23.2 in)
Basic Weight:	
With Oil and Full Fuel Tank	54 kg (119 lb)
Minimum Turning Radius	1,600 mm (63.0 in)
Engine:	
Engine Type	Air cooled 2-stroke, gasoline torque induction
Cylinder Arrangement	Single cylinder, Forward inclined
Displacement	59 cm <sup>3</sup>
Bore × Stroke	44.0 × 39.2 mm (1.73 × 1.54 in)
Compression Ratio	6.6 : 1
Starting System	Recoil starter
Lubrication System	Separate lubrication (Yamaha Autolube)
Oil Type or Grade:	
Engine Oil	Yamalube 2-cycle oil or Air cooled 2-stroke engine oil
Transmission Oil	Yamalube 4-cycle oil or SAE 10W30 type SE motor oil
Oil Capacity:	
Oil Tank (Engine Oil)	0.7 L (0.62 Imp qt, 0.74 US qt)
Transmission Oil	
Periodic Oil Change	0.30 L (0.26 Imp qt, 0.32 US qt)
Total Amount	0.35 L (0.31 Imp qt, 0.37 US qt)
Air Filter	Wet type element
Fuel:	
Type	Regular gasoline
Tank Capacity	4.0 L (0.88 Imp gal, 1.06 US gal)
Reserve Amount	0.8 L (0.18 Imp gal, 0.21 US gal)
Carburetor:	
Type/Manufacturer	VM12SC/MIKUNI

Model	YT60L
Spark Plug: Type/Manufacturer Gap	BP6HS/NGK, W20FP-U/NIPPONDENSO 0.6~0.7 mm (0.024~0.028 in)
Clutch Type	Wet, Automatic, Wet centrifugal clutch
Transmission: Primary Reduction System Primary Reduction Ratio Secondary Reduction System Secondary Reduction Ratio	Gear 63/33 (1.909) Shaft drive 19/15×49/7 (8.866)
Chassis: Frame Type Caster Angle Trail	Steel tube backbone 23°00' 45 mm (1.77 in)
Tire: Type Size (F) Size (R)	Tubeless 15×7-6 (1 pc) 15×7-6 (2 pcs)
Tire Pressure (Cold tire): S.T.D. Front/Rear Maximum Limit Front/Rear Minimum Limit Front/Rear	19.6~16.7 kPa (0.20~0.17 kg/cm <sup>2</sup> , 3~2 psi) 98.1 kPa (1.0 kg/cm <sup>2</sup> , 15 psi) 16.7 kPa (0.17 kg/cm <sup>2</sup> , 2.4 psi)
Brake: Rear Brake Type Operation	Drum brake Left hand operation
Suspension: Front Suspension Rear Suspension	Telescopic fork Rigid
Shock Absorber: Front Shock Absorber	Coil spring
Wheel Travel: Front Wheel Travel Rear Wheel Travel	60 mm (2.4 in) —
Shaft Drive: Grease Amount	Lithium base wheel bearing grease 80 cm <sup>3</sup> (2.8 imp oz, 2.7 US oz)
Electrical: Ignition System Generator System	C.D.I. Flywheel magneto

## II. MAINTENANCE SPECIFICATIONS ENGINE

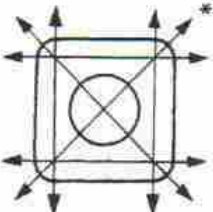
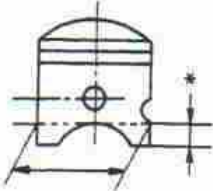
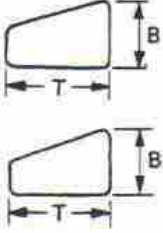
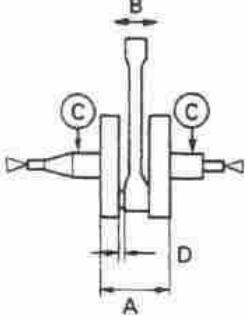
Model	YT60L						
Cylinder Head: Warp Limit 	<0.03 mm (0.0012 in)> *Lines indicate straightedge measurement.						
Cylinder: Bore Size Taper Limit Out of Round Limit	43.993 ~ 44.012 mm (1.7328 ~ 1.7320 in) <0.05 mm (0.002 in)> <0.01 mm (0.0004 in)>						
Piston: Piston Size/ Measuring Point*   Piston Clearance Oversize 1st 2nd Piston offset	43.952 ~ 43.972 mm (1.7304 ~ 1.7312 in)  0.040 ~ 0.048 mm (0.0016 ~ 0.0019 in) 44.25 mm (1.74 in) 44.50 mm (1.75 in) 0.20 mm (0.0079 in)/ EX-side						
Piston Ring: Sectional Sketch   End Gap (Installed) Side Clearance (Installed)	<table border="0"> <tr> <td style="vertical-align: top;">               Top Ring                 2nd Ring             </td> <td style="vertical-align: top;">               Keystone                B = 1.5 mm (0.0591 in)                T = 1.8 mm (0.0709 in)                 Keystone                B = 1.5 mm (0.0591 in)                T = 1.8 mm (0.0709 in)             </td> </tr> <tr> <td style="vertical-align: top;">               Top Ring                2nd Ring             </td> <td style="vertical-align: top;">               0.15 ~ 0.30 mm (0.0059 ~ 0.0118 in)                0.15 ~ 0.30 mm (0.0059 ~ 0.0118 in)             </td> </tr> <tr> <td style="vertical-align: top;">               Top Ring                2nd Ring             </td> <td style="vertical-align: top;">               0.03 ~ 0.05 mm (0.0012 ~ 0.0020 in)                0.03 ~ 0.05 mm (0.0012 ~ 0.0020 in)             </td> </tr> </table>	Top Ring  2nd Ring	Keystone B = 1.5 mm (0.0591 in) T = 1.8 mm (0.0709 in)  Keystone B = 1.5 mm (0.0591 in) T = 1.8 mm (0.0709 in)	Top Ring 2nd Ring	0.15 ~ 0.30 mm (0.0059 ~ 0.0118 in) 0.15 ~ 0.30 mm (0.0059 ~ 0.0118 in)	Top Ring 2nd Ring	0.03 ~ 0.05 mm (0.0012 ~ 0.0020 in) 0.03 ~ 0.05 mm (0.0012 ~ 0.0020 in)
Top Ring  2nd Ring	Keystone B = 1.5 mm (0.0591 in) T = 1.8 mm (0.0709 in)  Keystone B = 1.5 mm (0.0591 in) T = 1.8 mm (0.0709 in)						
Top Ring 2nd Ring	0.15 ~ 0.30 mm (0.0059 ~ 0.0118 in) 0.15 ~ 0.30 mm (0.0059 ~ 0.0118 in)						
Top Ring 2nd Ring	0.03 ~ 0.05 mm (0.0012 ~ 0.0020 in) 0.03 ~ 0.05 mm (0.0012 ~ 0.0020 in)						
Crankshaft:   Crank Width "A" Run Out Limit "C" Small End Free Play "B" <Limit> Connecting Rod Big End Side Clearance "D"	37.90 ~ 37.95 (1.4921 ~ 1.4941 in) <0.03 mm (0.0012 in)> 0.4 ~ 0.8 L <2.0 mm (0.0787 in)> 0.35 ~ 0.55 mm (0.0138 ~ 0.0217 in)						



Model	YT60L
<b>Clutch:</b> Clutch Shoe Thickness/ Quantity Wear Limit Clutch Spring Free Length/ Quantity Clutch Spring Minimum Length Clutch In Revolution Clutch Stall Revolution (With power reduction plate) Clutch In Revolution Clutch Stall Revolution (Without power reduction plate)	1.0 mm (0.04 in) × 2 <0.7 mm (0.03 in)> 36.8 mm (1.45 in) × 2 <34.8 mm (1.37 in)> 2,500 ~ 2,750 r/min 2,800 ~ 3,000 r/min 2,500 ~ 2,750 r/min 3,400 ~ 3,600 r/min
<b>Transmission:</b> Main Axle Deflection Limit	0.2 mm (0.008 in)
Air Filter Oil Grade (Oiled Filter)	Foam-air-filter oil or SAE 10W30 type SE motor oil
<b>Carburetor:</b> Type/Manufacturer/Quantity I.D. Mark Main Jet (M.J.) Jet Needle-clip Position (J.N.) Needle Jet (N.J.) Cutaway (C.A.) Pilot Jet (P.J.) Pilot Air Screw (P.A.S.) Valve Seat Size (V.S.) Starter Jet (G.S.) Float Height Fuel Level Engine Idling Speed	VM12SC/MIKUNI/1 36R00 #92.5 3X1-3 E-8 4.0 #40 2 (turns out) ø1.2 40 16.5 ± 1 mm (0.65 ± 0.04 in) 3 ± 1 mm (0.12 ± 0.04 in) 1,700 r/min
<b>Reed Valve:</b> Thickness* Valve Stopper Height Valve Bending Limit	 0.2 mm (0.08 in) 4.8 mm (0.19 in) 0.8 mm (0.03 in)
<b>Lubrication System:</b> Autolube Pump-Color Code -Minimum Stroke -Maximum Stroke -Minimum Output/200 Stroke -Maximum Output/200 Stroke Pully Adjusting Mark At idle	Separate lubrication (Yamaha autolube pump) Yellow 0.25 ~ 0.30 mm (0.010 ~ 0.012 in) 1.00 ~ 1.15 mm (0.039 ~ 0.045 in) 0.481 ~ 0.577 cm <sup>3</sup> (0.017 ~ 0.020 Imp oz, 0.016 ~ 0.020 US oz) 1.924 ~ 2.213 cm <sup>3</sup> (0.068 ~ 0.078 Imp oz, 0.065 ~ 0.075 US oz)
Middle Gear Backlash	0.04 ~ 0.60 mm (0.0016 ~ 0.0236 in)
Final Gear Backlash	0.03 ~ 0.50 mm (0.0012 ~ 0.0197 in)

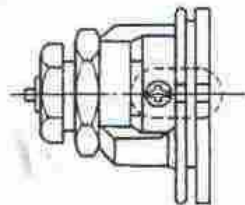

## TIGHTENING TORQUE

		Size	Q'ty	Nm	m · kg	ft · lb	Remarks
Cylinder, Cylinder Head	Nut	M6	4	10	1.0	7.2	
Spark Plug	—	M14	1	20	2.0	14	
Flywheel Magneto	Nut	M12	1	43	4.3	31	
Autolube Pump	Bolt	M5	2	4	0.4	2.9	
Pump Cover	Screw	—	1	4	0.4	2.0	
Carburetor Joint	Bolt	M6	4	9	0.9	6.5	
Air Filter Cover	Bolt	M6	1	6	0.6	4.3	
Exhaust Pipe	Bolt	M6	2	9	0.9	6.5	
Muffler	Flange Bolt	M8	2	27	2.7	19	
Silencer	Flange Bolt	M6	1	12	1.2	8.7	
Muffler Clamp	Flange Bolt	M8	1	20	2.0	14	
Crankcase	Bolt	M6	8	9	0.9	6.5	
Right Crankcase Cover	Bolt	M6	5	9	0.9	6.5	
Drain Bolt	Bolt	M8	1	18	1.8	13	
Crankshaft Oil Seal Retainer	Bolt	M6	1	9	0.9	6.5	
Recoil Starter	Bolt	M5	3	4	0.4	2.9	
Recoil Starter Pulley	Bolt	M6	3	10	1.0	7.2	APPLY LOCTITE®
Primary Drive Gear	Nut	M10	1	30	3.0	22	
Main Axle Bearing Retainer	Bolt	M6	2	12	1.2	8.7	
Middle Drive Shaft Retainer	Screw	M45	1	60	6.0	43	LEFT HAND THREADS
Final Drive Shaft Retainer	Screw	M35	1	50	5.0	36	
Rear Wheel Bearing Retainer	Bolt	M6	3	12	1.2	8.7	
Final Gear Housing & Rear Hub	Flange Bolt	M6	6	10	1.0	7.2	APPLY YAMABOND #4®
CDI Magneto Base	Flange Bolt	M6	2	9	0.9	6.5	

## CHASSIS

Model	YT60L
<b>Steering System:</b> Steering Bearing Type No./ Size of Steel Balls Upper Lower	Ball bearing  26 pcs/ 5/32 in 22 pcs/ 3/16 in
<b>Front Suspension:</b> Front Fork Travel Front Spring Free Length <Limit> Spring Rate/ Stroke  Optional Spring Grease Grade	60 mm (2.362 in) 115 mm (4.518 in) <110.0 mm (4.331 in)> $K_1 = 4.531 \text{ N/mm (0.462 kg/mm, 25.863 lb/in)}$ 0 ~ 65 mm (0 ~ 2.559 in)  No Lithium base wheel bearing grease
<b>Wheel:</b> Front Wheel Type Rear Wheel Type Front Rim Size/ Material Rear Rim Size/ Material Rim-Run-out-Limit Vertical Lateral	Disc Wheel Disc Wheel 5.5 × 6/ Steel 5.5 × 6/ Steel  <2.0 mm (0.08 in)> <2.0 mm (0.08 in)>
<b>Drum Brake:</b> Type Drum Inside Dia. <Limit> Lining Thickness <Limit> Shoe Spring Free Length	Leading and trailing 110 mm (4.33 in) <111 mm (4.37 in)> 4.0 mm (0.16 in) <2.0 mm (0.08 in)> 34.5 mm (1.36 in)
<b>Brake Lever &amp; Brake Pedal:</b> Brake Lever Free Play/ Position	5 ~ 8 mm (0.20 ~ 0.32 in)/at lever end

## TIGHTENING TORQUE

		Bolt/Thread Size	Q'ty	Nm	m · kg	ft · lb	Remarks
Front Axle	Nut	M12 × 1.25	1	50	5.0	36	
Wheel Panel	Nut	M8 × 1.25	9	28	2.8	20	
Steering Stem	Bolt	M10 × 1.25	1	32	3.2	23	
Steering Stem	Ring nut	M25 × 1.25	1	—	—	—	SEE PAGE 2-9
Steering Crown & Front Fork	Bolt	M10 × 1.25	2	32	3.2	23	
Handlebars & Steering Crown	Nut	M8 × 1.25	2	19	1.9	13	
Drive Shaft Housing & Engine	Bolt	M8 × 1.25	3	26	2.6	19	SEE PAGE 3-23
Drive Shaft Housing & Final Gear	Bolt	M8 × 1.25	3	26	2.6	19	APPLY LOCTITE SEE PAGE 5-11
Upper Engine Mounting	Nut	M10 × 1.25	1	48	4.8	35	
Lower Engine Mounting							
Bracket & Engine	Bolt	M6 × 1.0	2	10	1.0	7.2	
Lower Engine Mounting							
Bracket & Frame	Bolt	M8 × 1.25	2	23	2.3	17	

		Bolt/Thread Size	Q'ty	Nm	m · kg	ft · lb	Remarks
Footrest & Frame	Bolt	M8 × 1.25	2	23	2.3	17	SEE PAGE 5-11 USE LOCK WASHER USE COTTER PIN
Fuel Tank & Fuel Cock	Bolt	M6 × 1.0	2	5	0.5	3.6	
Final Gear Housing & Frame	Bolt	M10 × 1.25	2	50	5.0	36	
Rear Wheel Hub & Frame	Bolt	M10 × 1.25	2	50	5.0	36	
Rear Axle	Ring nut	M23 × 1.0	1	100	10	72	
Rear Axle	Nut	M12 × 1.25	2	65	6.5	47	
Rear Brake Lever	Nut	M6 × 1.0	1	9	0.9	6.5	

## ELECTRICAL

Model	YT60L
Voltage	6V
Ignition System: Ignition Timing (B.T.D.C.) Advancer Type	16° ± 1.5° at 5,000 r/min Electrical
<p>The graph plots Ignition Timing (B.T.D.C.) in degrees on the vertical axis (0 to 30) against Engine speed in <math>\times 10^3</math> r/min on the horizontal axis (0 to 10). The curve starts at approximately 5 degrees at 0.5 <math>\times 10^3</math> r/min, rises steeply to 16 degrees at 1.5 <math>\times 10^3</math> r/min, and then remains constant at 16 degrees for the rest of the speed range up to 10 <math>\times 10^3</math> r/min.</p>	
C.D.I.: Magneto-Model/ Manufacturer Pickup Coil Resistance (Color) Charging Coil Resistance (Color) C.D.I. Unit-Model/ Manufacturer	36R-00/YAMAHA 20 $\Omega$ ± 10% at 20°C (68°F) (W/R-B) 330 $\Omega$ ± 10% at 20°C (68°F) (B/R-B) 36R-00/YAMAHA
Ignition Coil: Model/ Manufacturer Minimum Spark Gap Primary Winding Resistance Secondary Winding Resistance	C2T4/YAMAHA 6 mm (0.24 in) 1.6 $\Omega$ ± 10% at 20°C (68°F) 6.6k $\Omega$ ± 10% at 20°C (68°F)
Charging System/Type	Flywheel magneto
Charging Coil Winding Resistance	0.63 $\Omega$ ± 10% at 20°C (68°F)
Engine Speed Control Unit: Model/ Manufacturer	36R-M0/YAMAHA

## GENERAL TORQUE SPECIFICATIONS

This chart specifies torque for standard fasteners with standard I.S.O. pitch threads. Torque specifications for special components or assemblies are included in the applicable sections of this book. To avoid warpage, tighten multi-fastener assemblies in a crisscross fashion, in progressive stages, until full torque is reached. Unless otherwise specified, torque specifications call for clean, dry threads. Components should be at room temperature.

A (Nut)	B (Bolt)	General torque specifications		
		Nm	m · kg	ft · lb
10 mm	6 mm	6	0.6	4.3
12 mm	8 mm	15	1.5	11
14 mm	10 mm	30	3.0	22
17 mm	12 mm	55	5.5	40
19 mm	14 mm	85	8.5	61
22 mm	16 mm	130	13.0	94

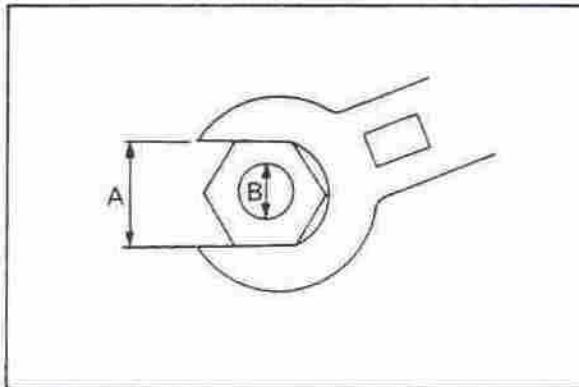

A. Distance across flats  
B. Outside thread diameter

## DEFINITION OF UNITS

Unit	Read	Definition	Measure
mm	millimeter	$10^{-3}$ meter	Length
cm	centimeter	$10^{-2}$ meter	Length
kg	kilogram	$10^3$ gram	Weight
N	Newton	$1 \text{ kg} \times \text{m}/\text{sec}^2$	Force
Nm	Newton meter	$\text{N} \times \text{m}$	Torque
m · kg	Meter kilogram	$\text{m} \times \text{kg}$	Torque
Pa	Pascal	$\text{N}/\text{m}^2$	Pressure
N/mm	Newton per millimeter	$\text{N}/\text{mm}$	Spring rate
L	Liter	—	Volume
$\text{cm}^3$	Cubic centimeter	—	or Capacity
r/min	Rotation per minute	—	Engine Speed

# CONVERSION TABLES

Metric to inch system		
Known	Multiplier	Result
m · kg	7.233	ft · lb
m · kg	86.80	in · lb
cm · kg	0.0723	ft · lb
cm · kg	0.8680	in · lb
kg	2.205	lb
g	0.03527	oz
km/lit	2.352	mpg
km/hr	0.6214	mph
km	0.6214	mi
m	3.281	ft
m	1.094	yd
cm	0.3937	in
mm	0.03937	in
cc (cm <sup>3</sup> )	0.03382	oz (US liq)
cc (cm <sup>3</sup> )	0.06102	cu in
lit (liter)	2.1134	pt (US liq)
lit (liter)	1.057	qt (US liq)
lit (liter)	0.2642	gal (US liq)
kg/mm	56.007	lb/in
kg/cm <sup>2</sup>	14.2234	psi (lb/in <sup>2</sup> )
Centigrade (°C)	9/5 (°C) + 32	Fahrenheit (°F)

Inch to metric system		
Known	Multiplier	Result
ft · lb	0.13826	m · kg
in · lb	0.01152	m · kg
ft · lb	13.831	cm · kg
in · lb	1.1521	cm · kg
lb	0.4535	kg
oz	28.352	g
mpg	0.4252	km/lit
mph	1.609	km/hr
mi	1.609	km
ft	0.3048	m
yd	0.9141	m
in	2.54	cm
in	25.4	mm
oz (US liq)	29.57	cc (cm <sup>3</sup> )
cu in	16.387	cc (cm <sup>3</sup> )
pt (US liq)	0.4732	lit (liter)
qt (US liq)	0.9461	lit (liter)
gal (US liq)	3.785	lit (liter)
lb/in	0.017855	kg/mm
psi (lb/in <sup>2</sup> )	0.07031	kg/cm <sup>2</sup>
Fahrenheit (°C)	5/9 (°F - 32)	Centigrade (°F)

# EXPLODED DIAGRAMS

## LEFTSIDE CRANKCASE

### PISTON:

**PISTON CLEARANCE:**  
 0.040 - 0.048 mm (0.0016 - 0.0019 in)  
**OVER SIZE:**  
 1ST: 44.25 mm (0.74 in)  
 2ND: 44.50 mm (1.75 in)

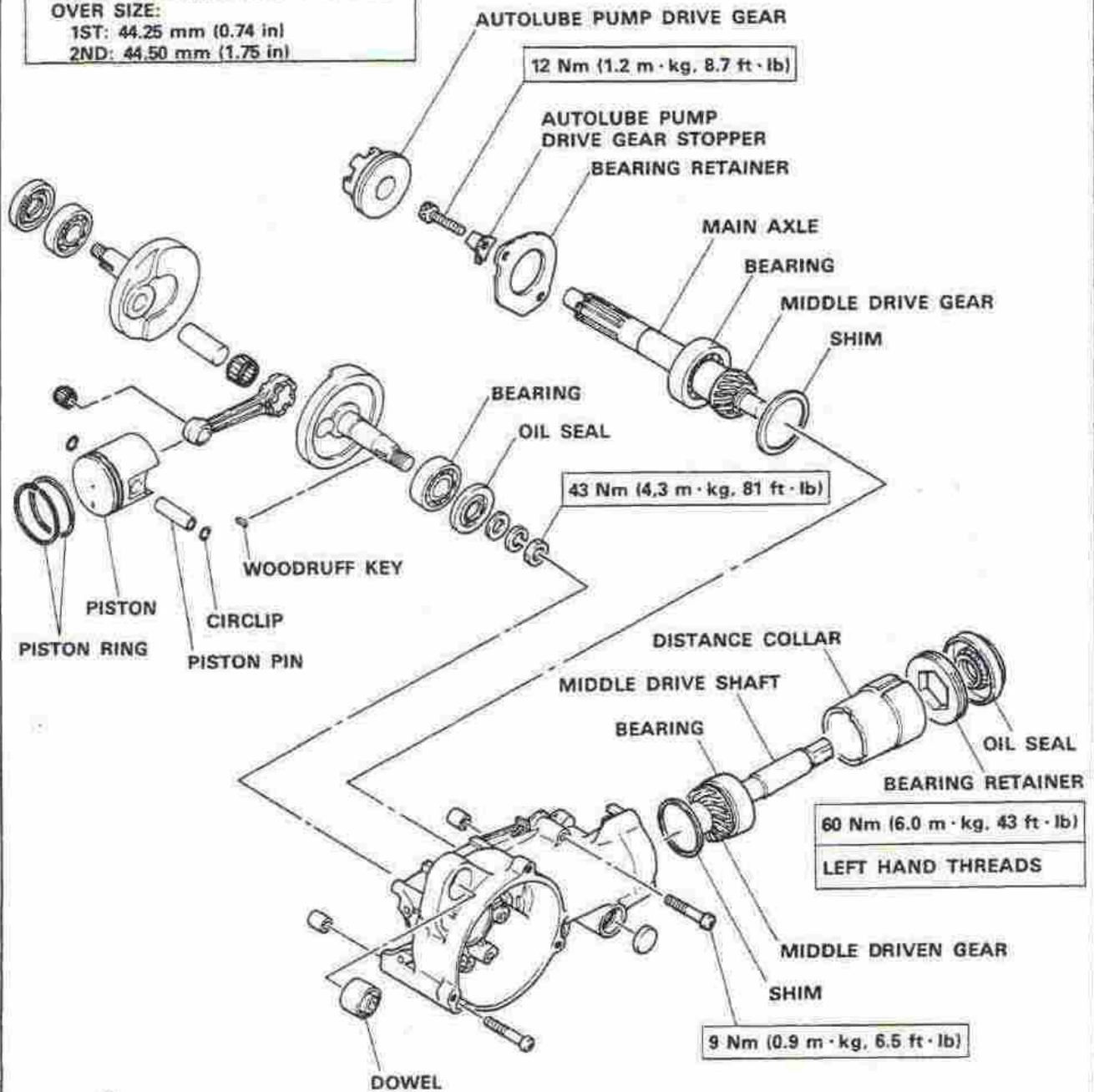

### CRANKSHAFT:

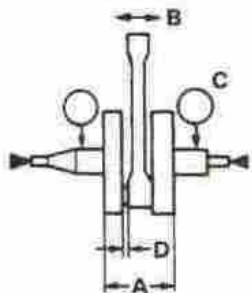

A: 37.90 - 37.95 mm (1.4921 - 1.4941 in)  
 B: 0.4 - 0.8 mm (0.0157 - 0.0315 in)  
 C: < 0.03 mm (0.0012 in) >  
 D: 0.35 - 0.55 mm (0.0138 - 0.0217 in)

**MIDDLE GEAR LASH:**  
 0.04 - 0.60 mm (0.0016 - 0.0236 in)

CLUTCH SHOE:  
S.T.D. THICKNESS: 1 mm (0.04 in)  
WEAR LIMIT: 0.7 mm (0.03 in)

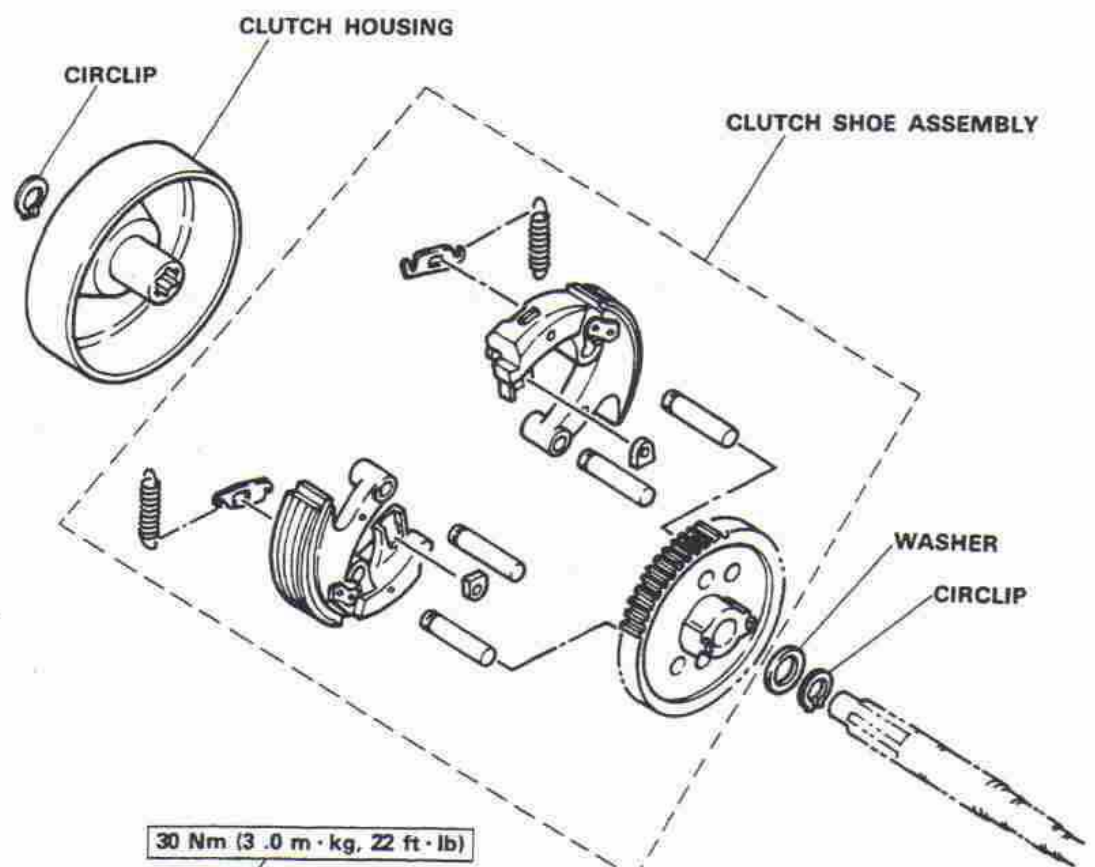

30 Nm (3.0 m·kg, 22 ft·lb)

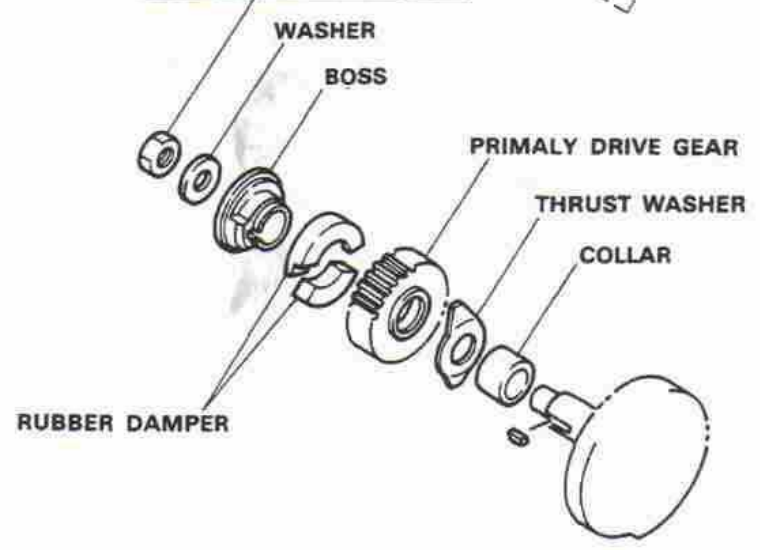



# FORK/STEERING HEAD

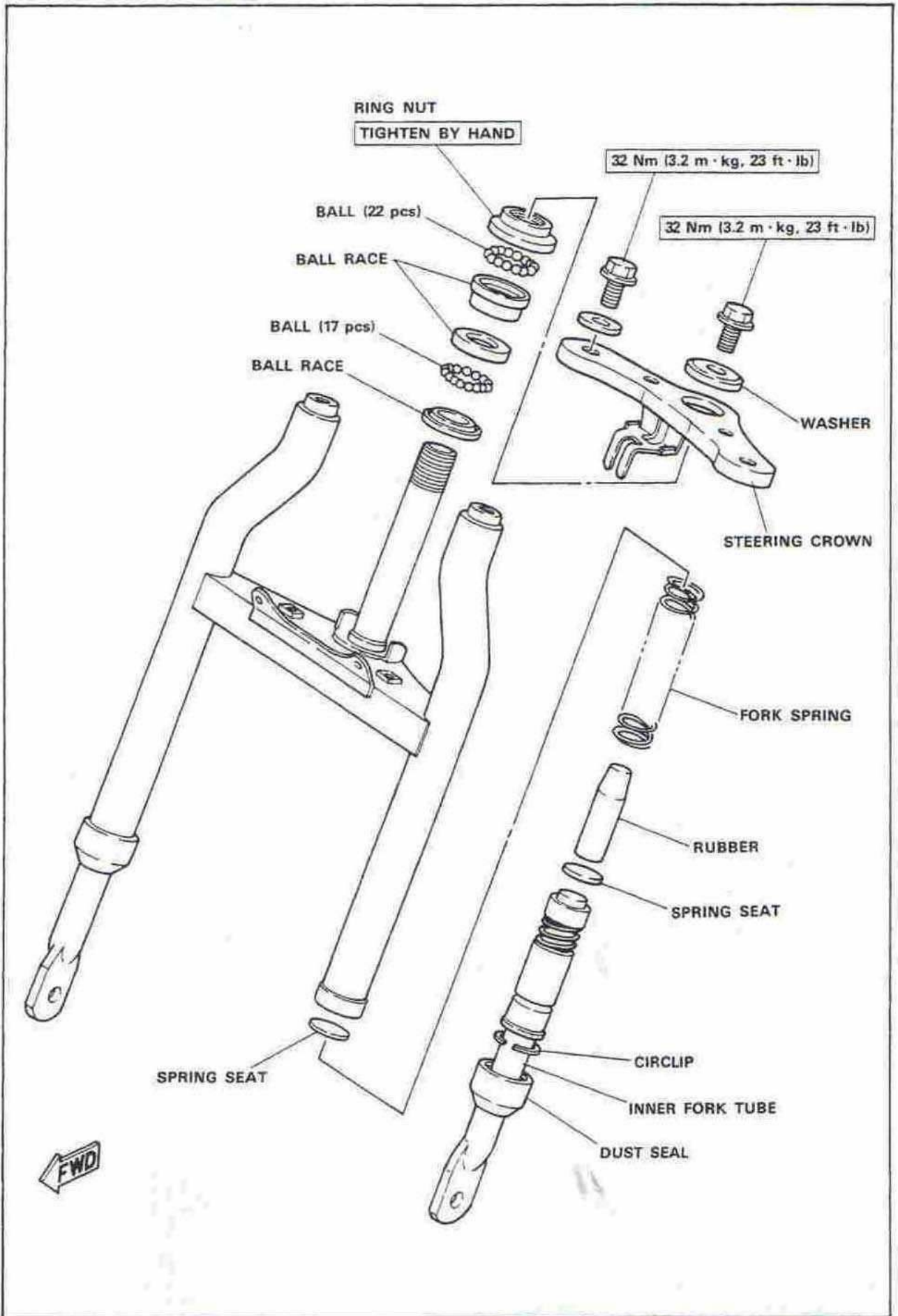

**FRONT TIRE**

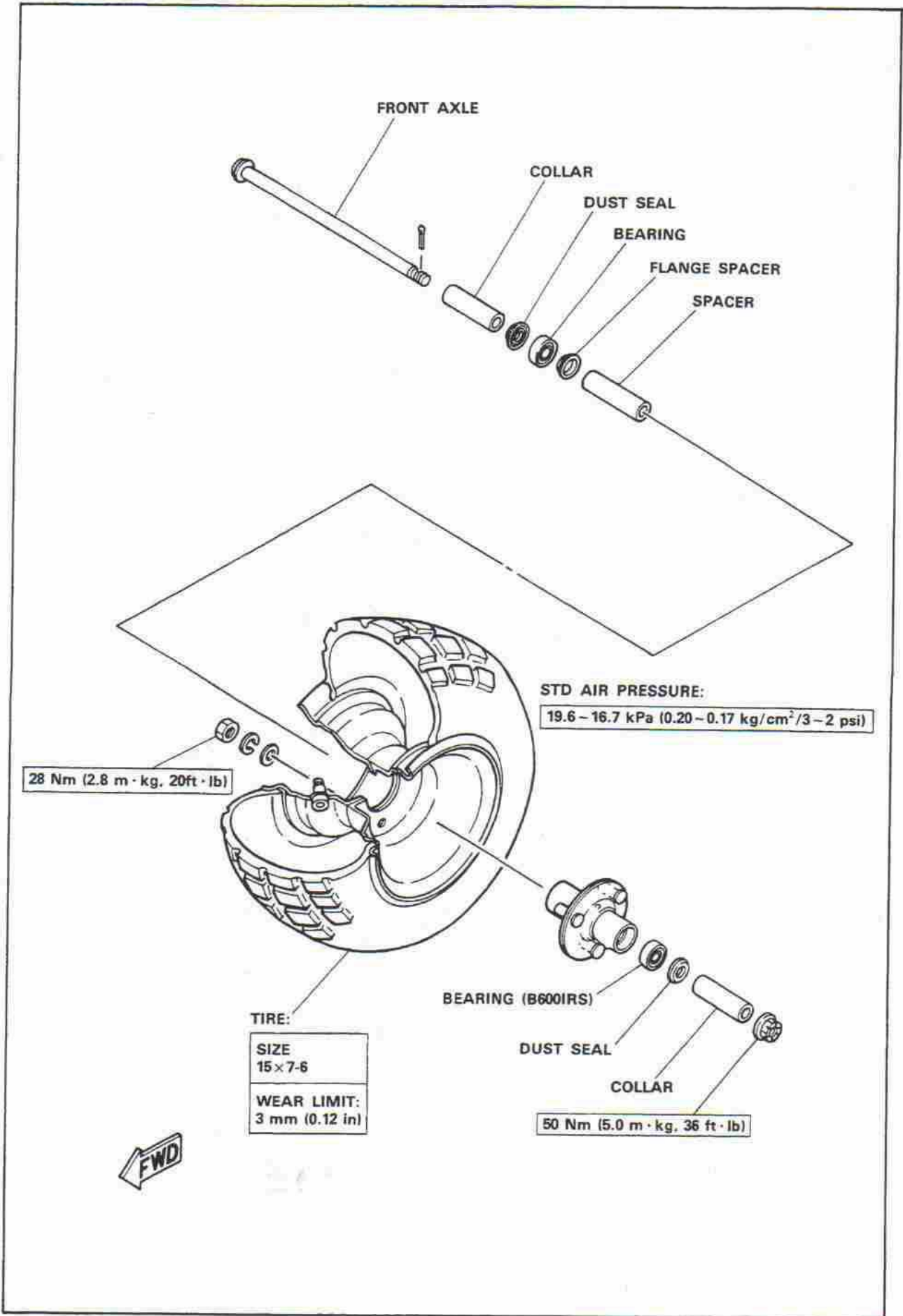

# REAR WHEEL HUB

## REAR BRAKE SHOE:

**WEAR LIMIT**  
2 mm (0.08 in)

## TIRE PRESSURE:

STD: 19.6 - 16.7 kPa (0.20 - 0.17 kg/cm<sup>2</sup>, 3 - 2 psi)

## TIRE:

**SIZE:**  
15x7-6 (spcs)  
**WEAR LIMIT:**  
3 mm (0.12 in)

### RING NUT

100 Nm (10 m·kg, 72 ft·lb)

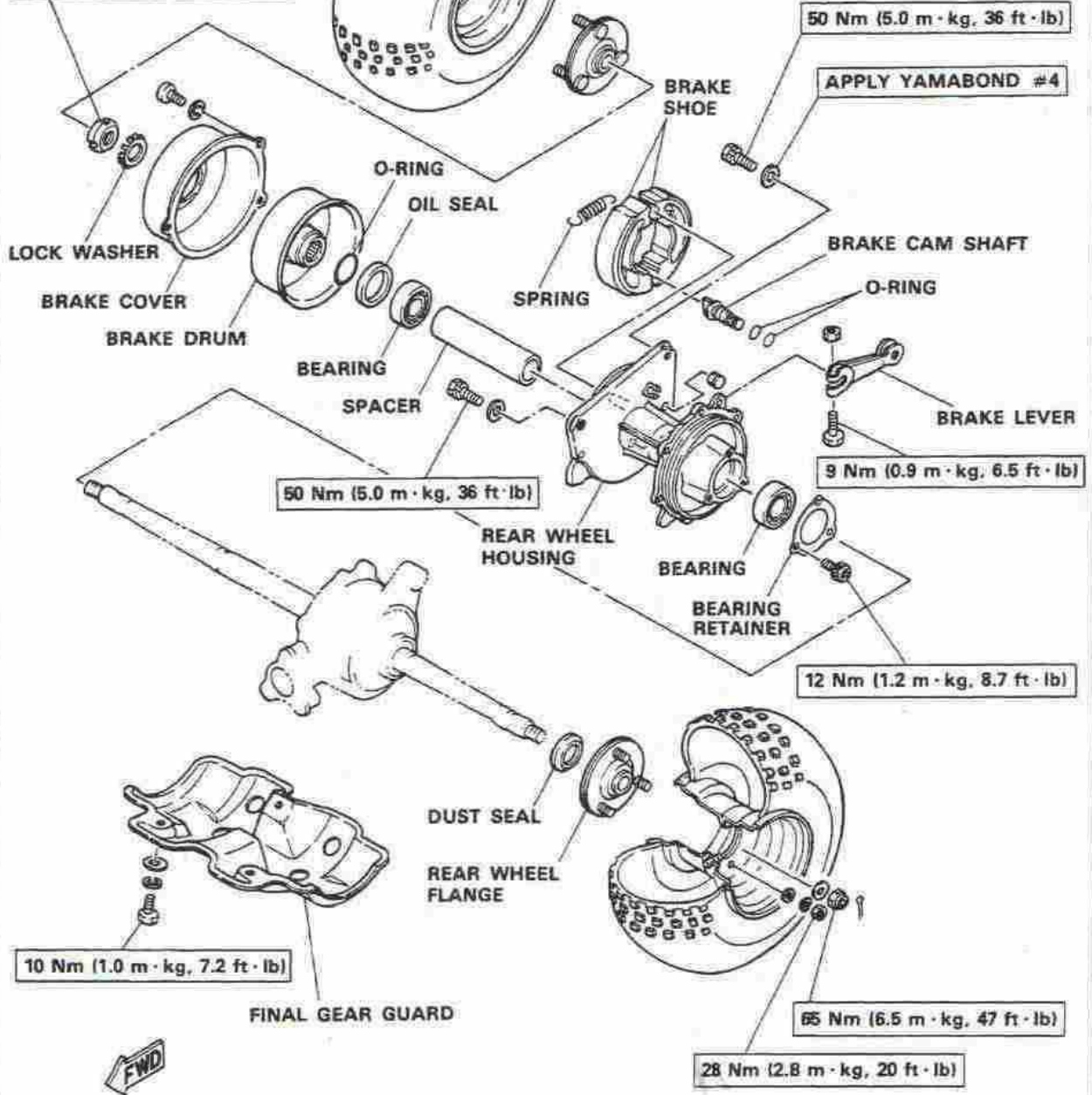

# FINAL GEAR

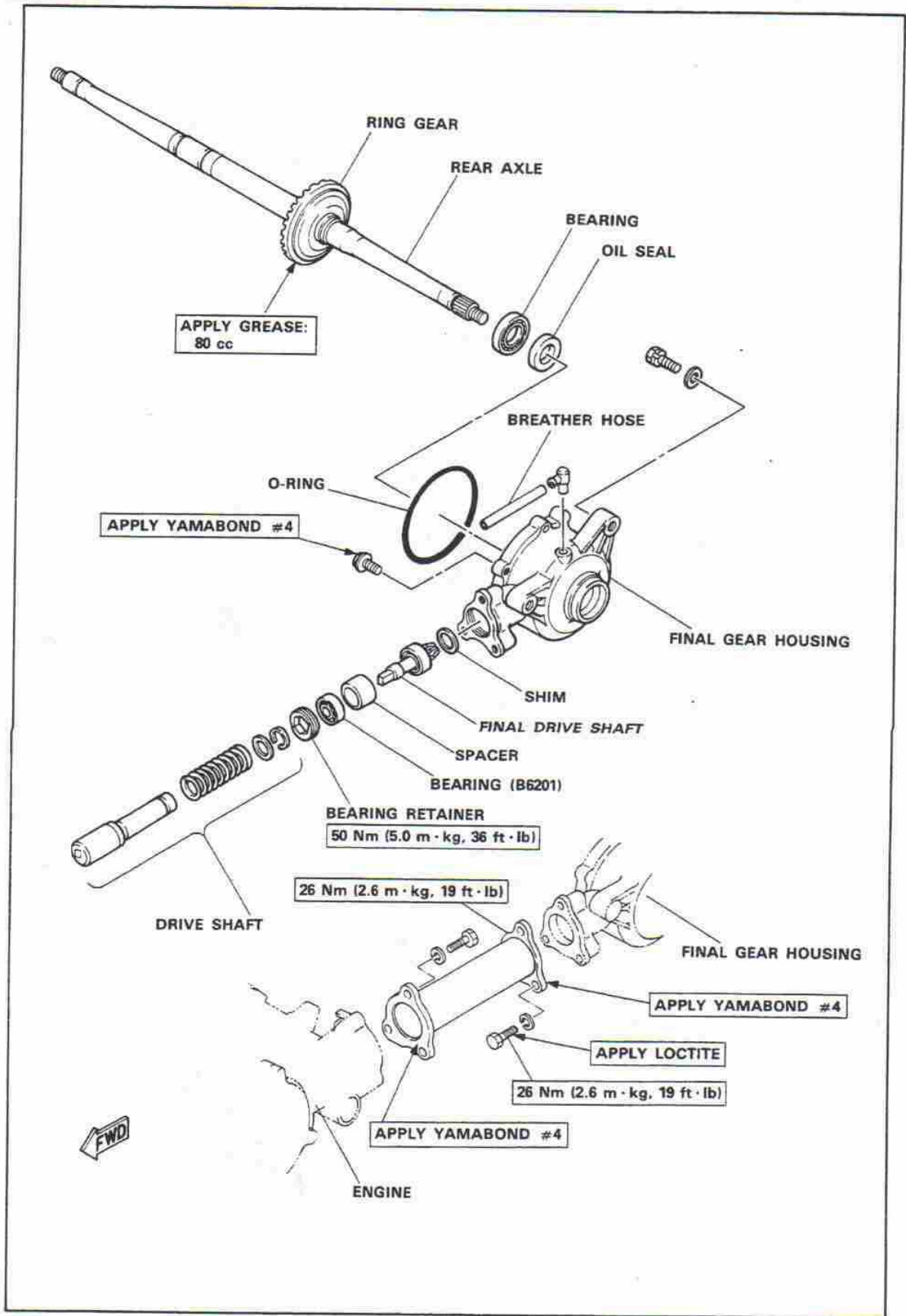

# ELECTRICAL COMPONENTS

## SPECIFICATION: (RESISTANCE)

IGNITION COIL:  
 PRIMARY:  $1.6\Omega \pm 10\%$   
 SECONDARY:  $6.6\Omega \pm 20\%$

PICKUP COIL:  $20\Omega \pm 10\%$  (W/R-B)  
 CHARGE COIL:  $330\Omega \pm 10\%$  (B/R-B)  
 CHARGING COIL:  $0.63\Omega \pm 10\%$  (W-B)

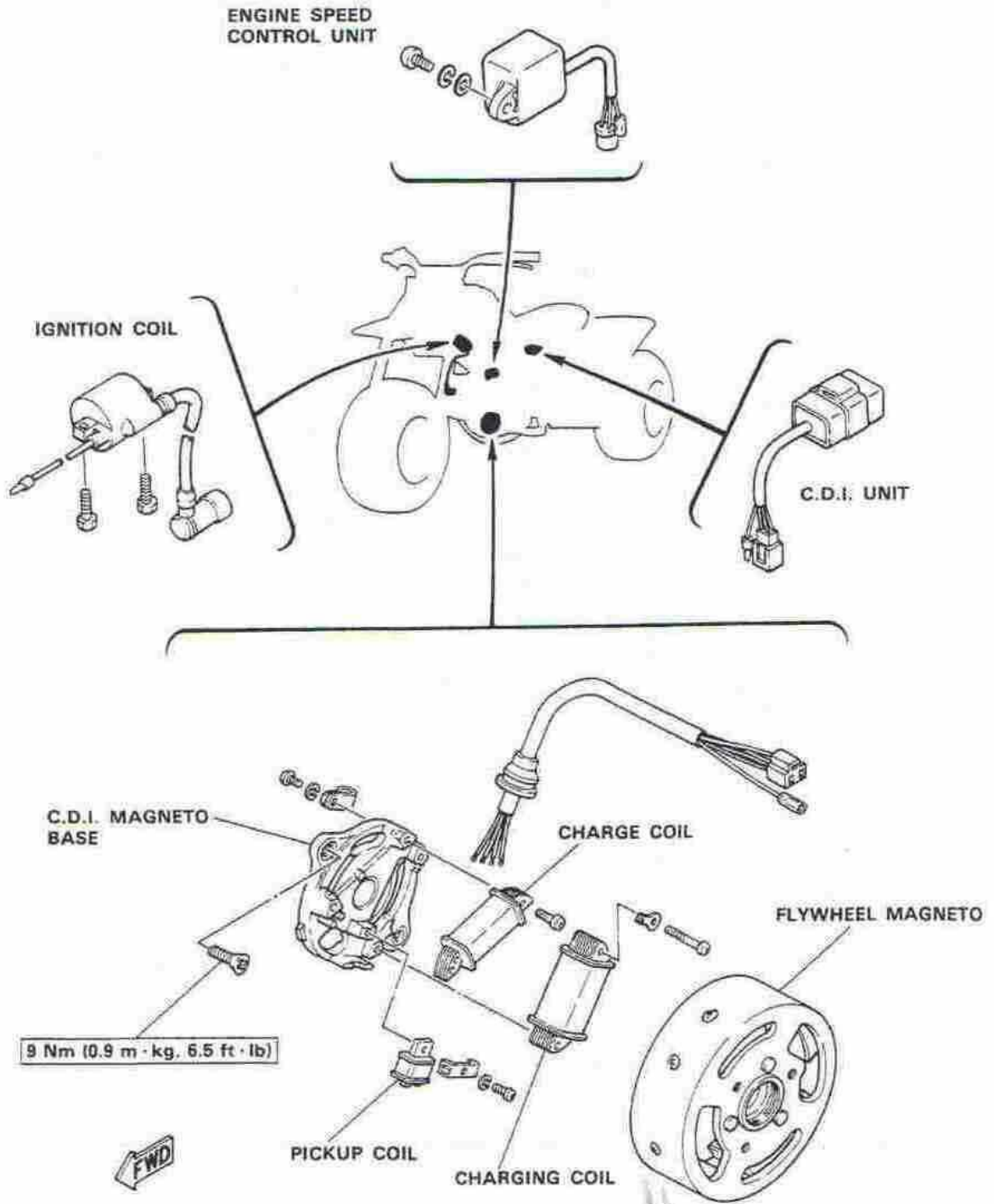

# CABLE ROUTING

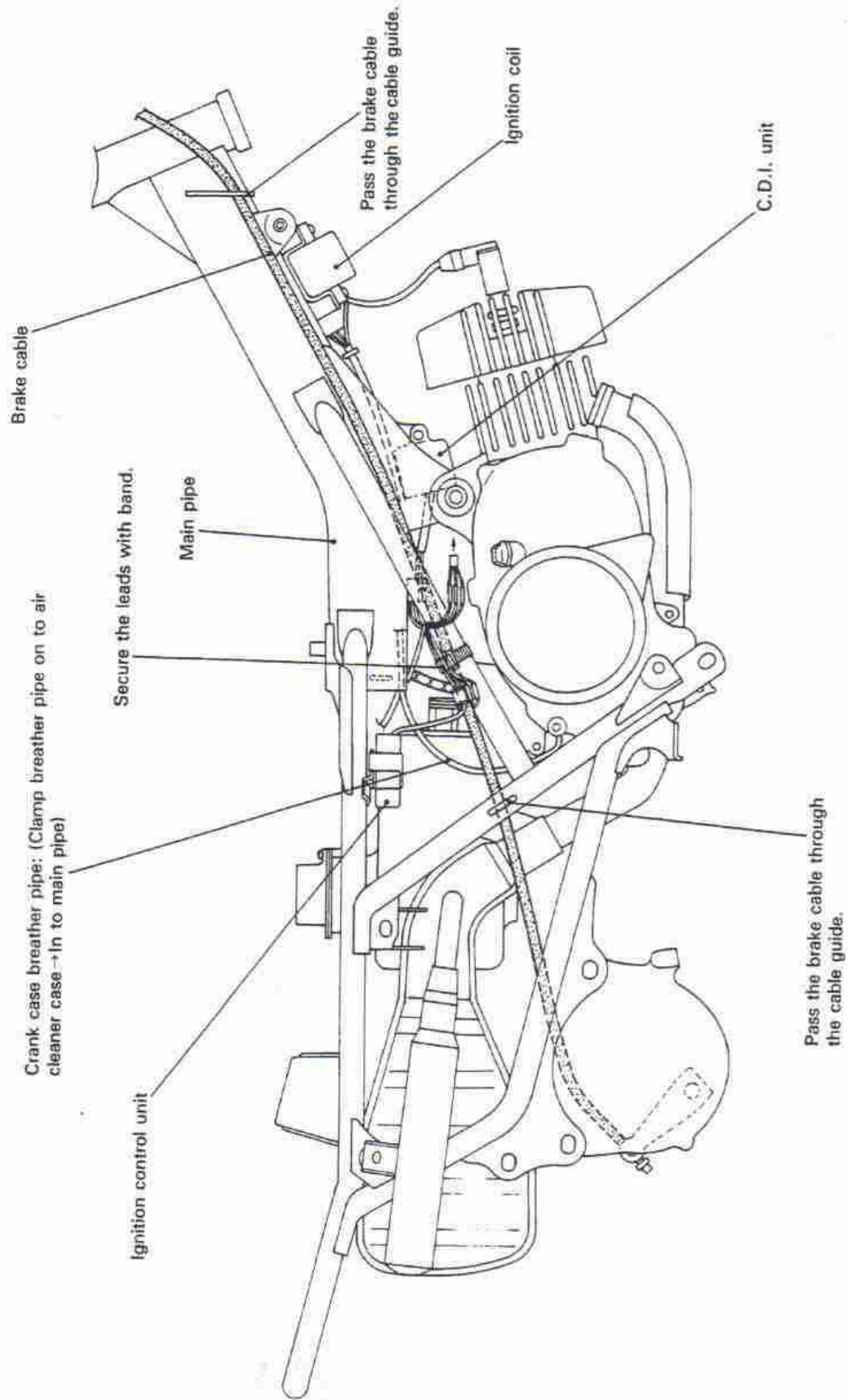

Pass the throttle cable 1, the handlebar switch lead, and starter cable through the cable guide.

**Starter cable:**  
(Carburetor → Pass starter cable along main pipe → Left side of head pipe starter lever stay.)

Main pipe

Cable cylinder

Pass the throttle cable 2.  
(Carburetor → Cable cylinder)

Pass the autolube pump cable:  
(Autolube pump → Right side of carburetor → Cable cylinder)

Pass the oil hose:  
(Oil tank → Left side of air cleaner case → Upper cross tube → Under intake manifold → Autolube pump)

Secure the engine stop switch lead with the band.

Engine stop switch

Pass the throttle cable 1 and the handlebar switch lead between the starter cable and the head pipe.

Ignition coil

Earth lead

Pass the wireharness through the cable guide.

High-tension cord

Fuel pipe:  
(Make sure the fuel pipe is not loosened.)

Pass the final-gear-case breather pipe:  
(Final gear case → Upper cross tube → Left side of air cleaner case → Under oil hose → Right side of intake manifold → into main pipe)

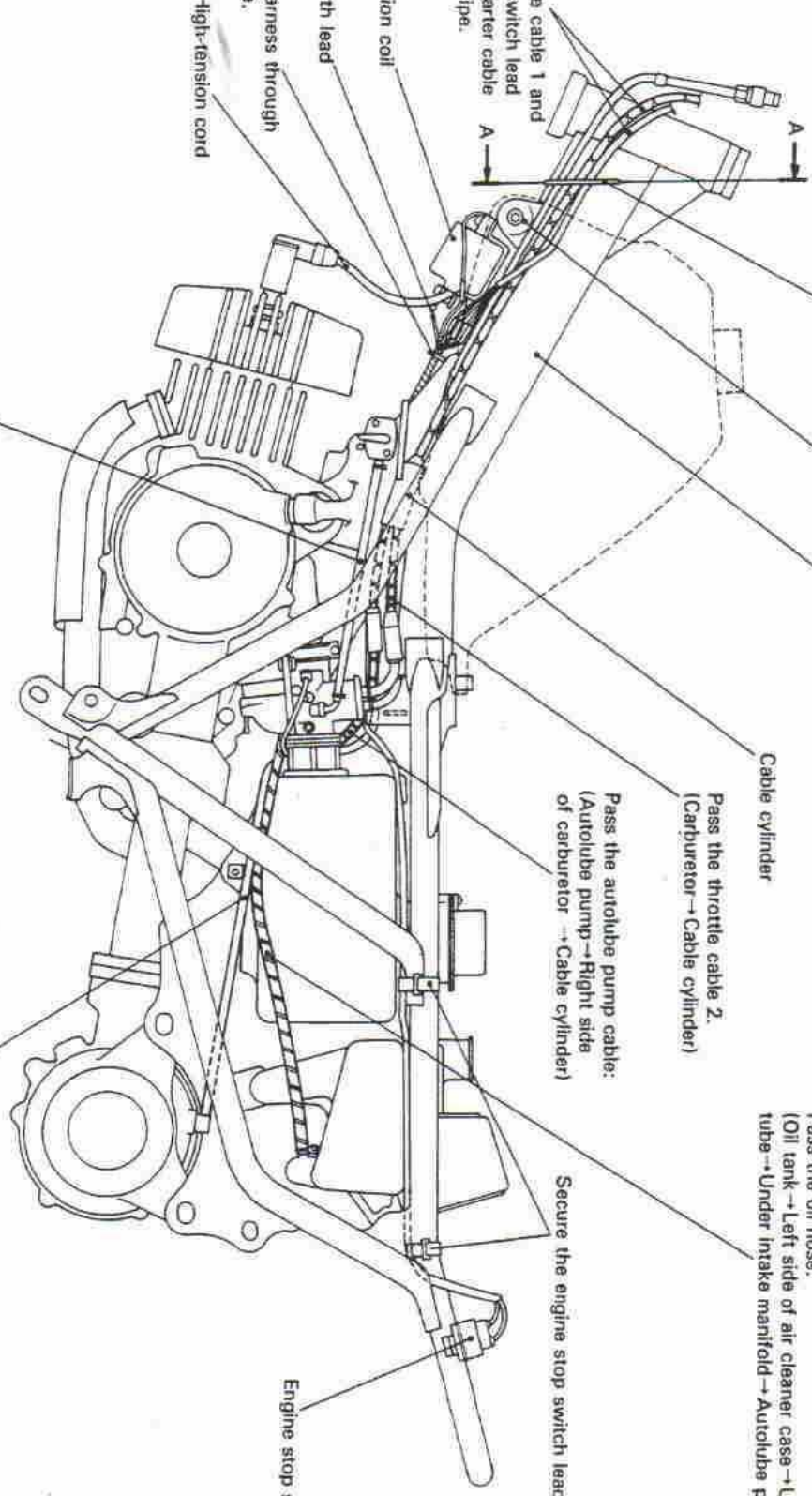

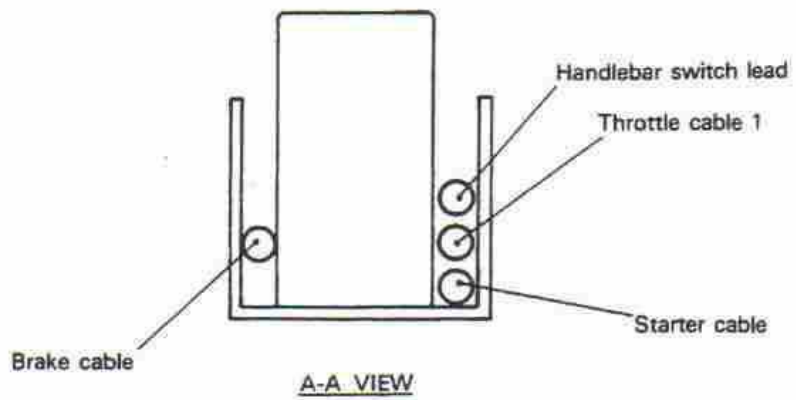

Handlebar switch lead:  
 (Pass the handlebar switch lead on the right side  
 of the starter lever stay.)

Throttle cable 1:  
 (Pass the throttle cable on the right side  
 of the starter lever stay.)

Starter lever stay

Secure the switch lead to  
 the handlebar with the band.

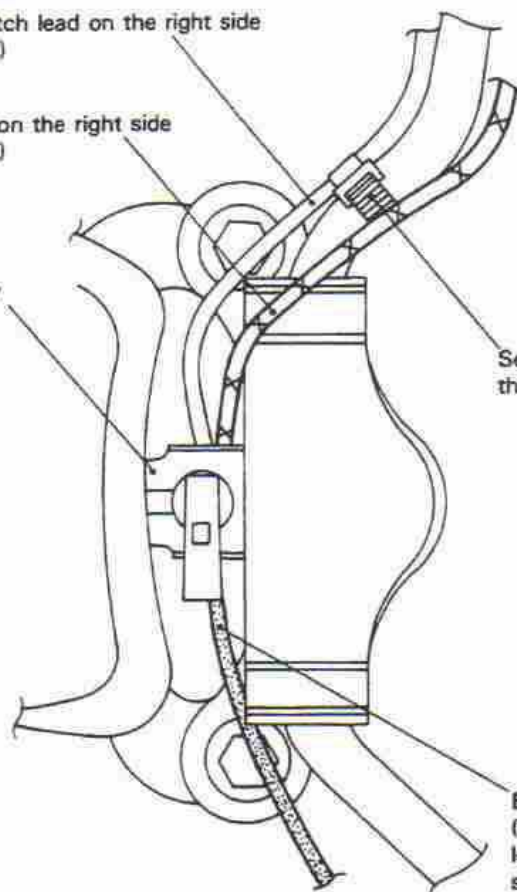

Brake cable:  
 (Pass the brake cable on the  
 left side of the starter lever  
 stay.)



# YT60L WIRING DIAGRAM

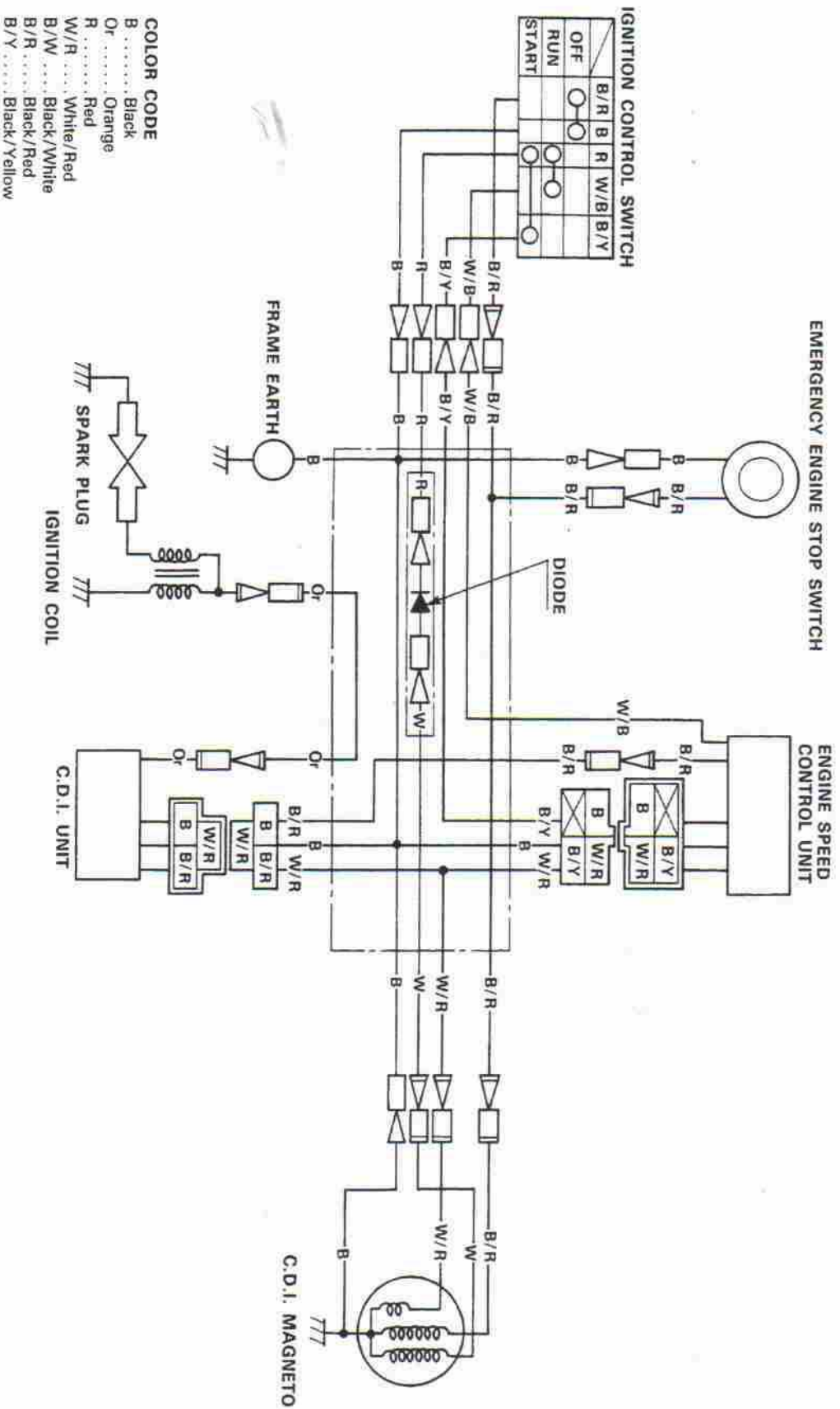

**COLOR CODE**

- B ..... Black
- Or ..... Orange
- R ..... Red
- W/R ..... White/Red
- B/W ..... Black/White
- B/R ..... Black/Red
- B/Y ..... Black/Yellow

Being a Yamaha owner, you obviously prefer a quality product.

**gēn·ū·īne**

*adj.* 1. Real 2. Authentic,  
not artificial 3. Yamaha.

GENUINE **YAMAHA** PARTS & ACCESSORIES

Don't compromise the quality and performance of your Yamaha with off-brand alternatives. You'll be getting exactly what you're paying for.