

CONTENTS

GENERAL INFORMATION	1
PERIODIC INSPECTIONS AND ADJUSTMENTS	2
ENGINE OVERHAUL	3
CARBURETION	4
CHASSIS	5
ELECTRICAL	6
APPENDICES	7

CHAPTER 1. GENERAL INFORMATION

MACHINE IDENTIFICATION	1-1
Frame serial number	1-1
Engine serial number	1-1
SPECIAL TOOLS	1-2
For tune-up	1-2
For engine service	1-2
For chassis service	1-3
For electrical components	1-4
Additional tools and supplies	1-4

GENERAL INFORMATION

MACHINE IDENTIFICATION

Frame serial number

The frame serial number is stamped into the right-side of the steering head pipe.

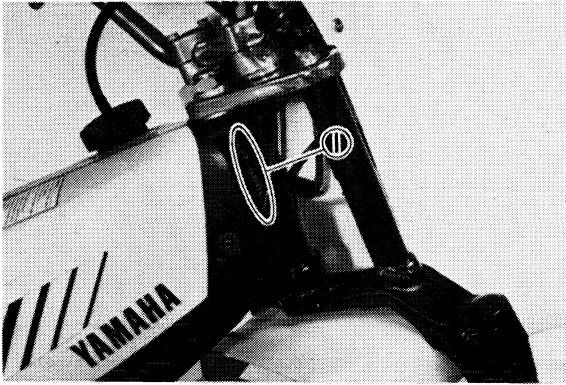

1. Frame serial number

Engine serial number

The engine serial number is stamped into the elevated part of the right rear section of the engine.

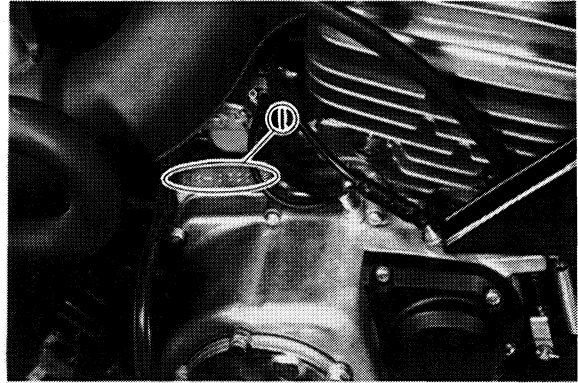

1. Engine serial number

NOTE:

The first three digits of these numbers are for model identification; the remaining digits are the unit production number.

Starting Serial Number:

YT175J 5V7-000101



SPECIAL TOOLS

The proper special tools are necessary for complete and accurate tune-up and assembly. Using the correct special tool will help prevent damage caused by the use of improper tools or improvised techniques.

For tune-up

1. Timing light
2. Tachometer

For engine service

1. Dial gauge
P/N 90890-03002-00

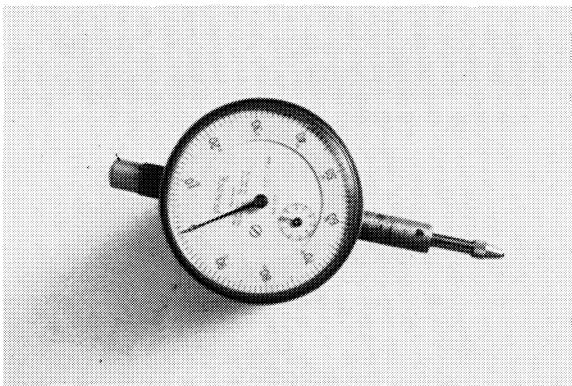

2. Dial gauge stand
P/N 90890-01256-00



3. Dial gauge needle
P/N 90890-03099-00

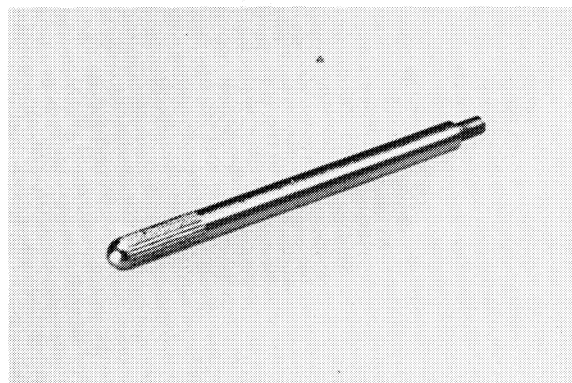

Tools 1, 2, and 3 are use to set the ignition timing.

4. Crankcase separation tool
P/N 90890-01135-00

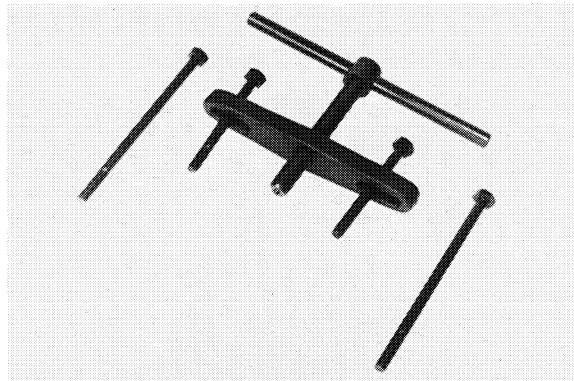

This tool is use to split the crankcase as well as remove the crankshaft from either case.

5. Crank installer pot
P/N 90890-01275-00

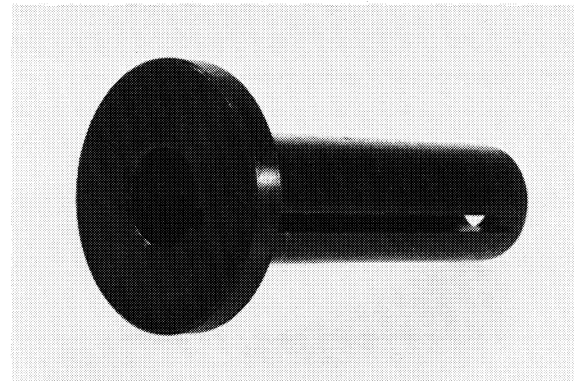

6. Crank installer bolt
P/N 90890-01275-00

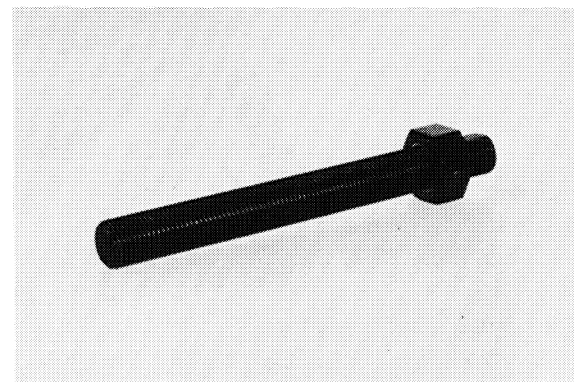

7. Spacer
P/N 90890-01288-00

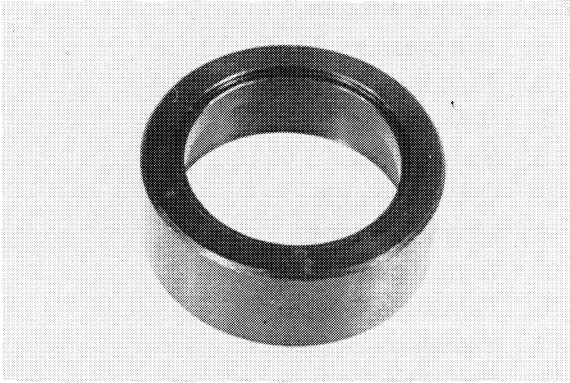

8. Crank installer bolt adapter
P/N 90890-01278-00

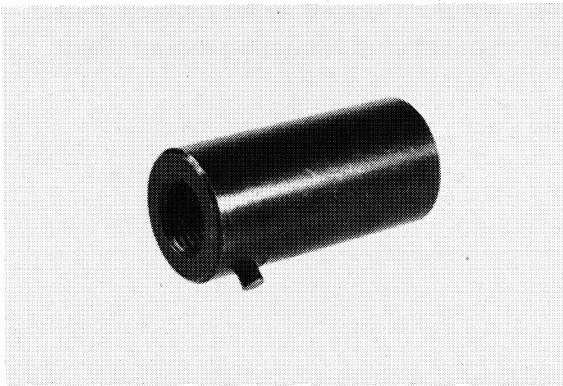

Tools 5, 6, 7, and 8 are use to install the crankshaft.

9. Flywheel puller
P/N 90890-01189-00

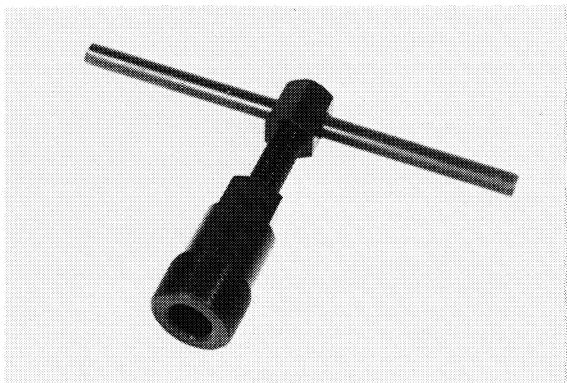

This tool is use to remove the flywheel magneto.

10. Flywheel holding tool
P/N 90890-01235-00

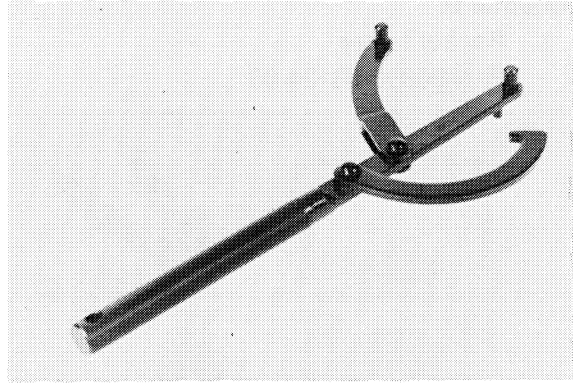

Use this tool to hold the flywheel magneto while removing or tightening the flywheel magneto securing nut.

For chassis service

1. Steering nut wrench
P/N 90890-01051-00

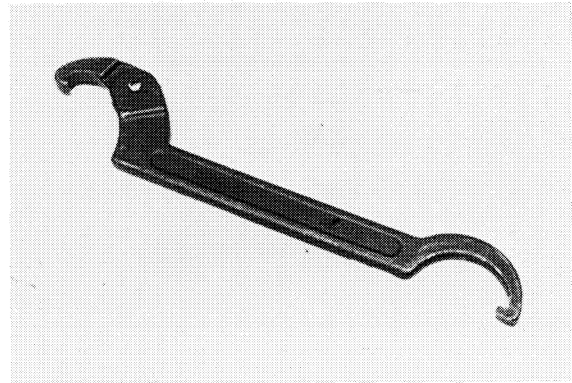

Use this wrench to put the proper tension on the steering head bearing.

2. Front-fork-cylinder holder
P/N 90890-01300-00

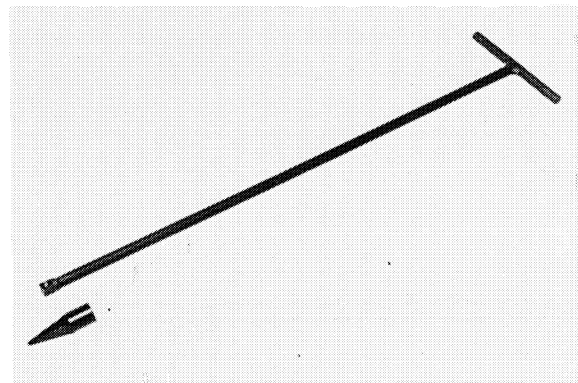

This tool is used to loosen and tighten the front fork cylinder holding bolt.

For electrical components

The use of these tools are described in Chapter 6.

1. Pocket tester
P/N 90890-03104-00

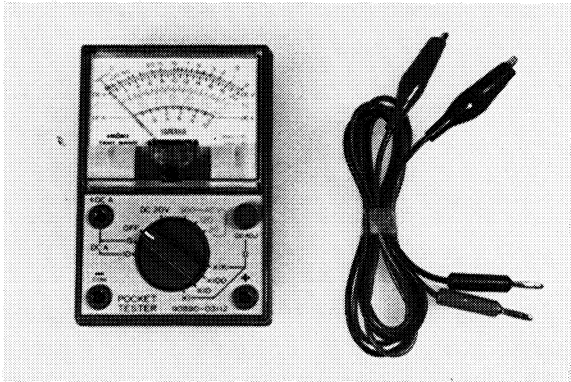

2. Electro tester
P/N 90890-03021-00

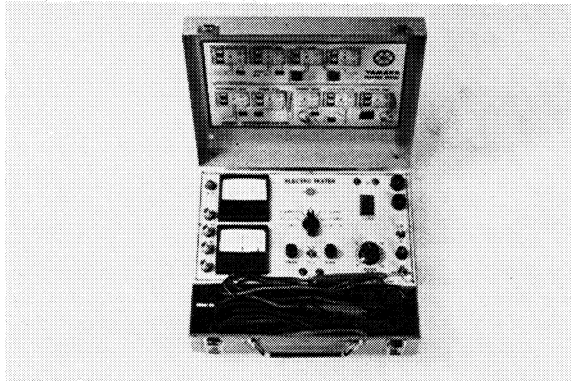

Additional tool and supplies

1. Thickness gauge set
2. Torque wrench
3. Tire pressure gauge
4. Fluid measuring cup
5. Micrometer
6. Slide caliper
7. Cylinder gauge
8. Magnetic stand
9. Grease gun
10. Yamalube 4-cycle oil
11. Yamalube 2-cycle oil
12. Yamabond #4
13. Yamaha chain and cable lube or SAE 10W30 motor oil
14. Medium weight wheel bearing grease
15. Locktit stud N'bearing mount (Red)

CHAPTER 2.

PERIODIC INSPECTIONS AND ADJUSTMENTS

INTRODUCTION	2-1
MAINTENANCE INTERVALS CHART	2-1
ENGINE	2-3
Spark plug	2-3
Fuel line	2-3
Over flow chamber	2-3
Idle speed	2-3
Throttle cable	2-3
Throttle lever	2-4
Autolube pump cable adjustment	2-4
Minimum pump stroke check and adjustment	2-4
Air bleeding	2-5
Engine oil	2-6
Checking the water release valve	2-6
Transmission oil	2-6
Checking ignition timing	2-7
CHASSIS	2-8
Air cleaner	2-8
Front brake shoe inspection	2-8
Rear brake pad inspection	2-8
Brake adjustment	2-9
Drive chain tension check	2-11
Drive chain tension adjustment	2-11
Drive chain cleaning and lubrication	2-11
Steering head adjustment	2-11
Wheel bearings	2-12
Fuel cock	2-13
Tires	2-13
Cable inspection and lubrication	2-14
Brake and change pedals/front and rear brake levers	2-14
ELECTRICAL	2-15
Headlight bulb replacement	2-15
Headlight beam adjustment	2-15

PERIODIC INSPECTIONS AND ADJUSTMENTS

INTRODUCTION

This chapter includes all information necessary to perform recommended inspections and adjustments. These preventive maintenance procedures, if followed, will ensure more reliable vehicle operation and a longer service life. The need for costly overhaul work will be greatly reduced. This information applies to vehicles already in service and to new vehicles that are being prepared for sale. All service technicians should be familiar with this entire chapter.

MAINTENANCE INTERVALS CHARTS

The following charts should be considered strictly as a guide to general maintenance and lubrication intervals. You must take into consideration that weather, terrain, geographical location, and a variety of individual uses. This time schedule should be altered to match individual owner's requirements. For example, if the machine is continually operated in an area of high humidity, then all parts must be lubricated much more frequently than shown on the chart to avoid damage caused by water to metal parts.

PERIODIC MAINTENANCE

Item	Remarks	Initial			Thereafter every	
		1 Month	3 Months	6 Months	6 Months	1 Year
Cylinder head/Exhaust system/ Spark arrester	Decarbonize		○	○	○	
Spark plug	Inspect/Cleaning or replace as required	○	○	○	○	
Air filter	Wet type— Must be washed and damped with Yamalube 2-cycle Oil or SAE 10W30 motor oil		○	○	○	
Water release valve	Check operation/ Foreign materials	○	○	○	1 Month	
Carburetor	Check operation/ Fittings		○	○	○	
	Clean/ Refit/ Adjust					○
Autolube pump	Check/ Adjust/ Air bleeding	○	○	○	○	
*Brake system (complete)	Check/ Adjust as required— Repair as required	○	○	○	3 Months	
Drive chain	Check/ Adjust as required/ Replace as required	○	○	○	1 Month	
Steering bearings	Check/ Adjust as required/ Replace as required			○	○	
*Wheels and tires	Check pressure/ Wear/ Balance/ Run out	○	○	○	○	
Fuel cock	Clean/ Flush tank as required	○	○	○	○	
*Lights	Check operation/ Replace as required	○	○	○	○	
*Fittings/ Fasteners	Tighten before each trip and/ or ...	○	○	○	○	

* Indicates pre-operation check items.

LUBRICATION INTERVALS

Item	Remarks	Type	Initial			Thereafter every	
			1 Month	3 Months	6 Months	6 Months	1 Year
*Transmission oil	Replace/Warm engine before draining	Yamalube 4-cycle oil or SAE 10W30 type SE motor oil	○	Check	○	○	
Throttle lever and housing	Apply lightly	Lithium base grease			○	○	
Brake lever	Apply lightly	Lithium base grease		○	○	○	
Brake cam shaft	Apply lightly	Lithium base grease		○	○	○	
Drive chain	Lubricate chain thoroughly	Motor oil SAE 30 ~ 50	○	○	○	1 Month	
Front forks	Drain completely – check specifications	Yamaha fork oil 10wt or SAE 10W30 type SE motor oil	○		○		1 Year
Steering bearings	Inspect thoroughly/pack moderately	Medium-weight wheel bearing grease			Check		2 Years
Wheel bearings	Do not over-pack yearly or ...	Medium-weight wheel bearing grease					○

* Indicates pre-operation check items.

ENGINE

Spark plug

1. Check electrode condition and wear, insulator color, and electrode gap.
2. Clean the spark plug with spark plug cleaner if necessary. Use a wire gauge to adjust the plug gap to the specification.
3. If the electrode becomes too worn, replace the spark plug.
4. When installing the plug, always clean the gasket surface, wipe off any grime that might be present on the surface of the spark plug, and torque the spark plug properly.

Standard spark plug: NGK BP7ES
Spark plug gap:
0.7 ~ 0.8 mm (0.028 ~ 0.031 in)
Spark plug tightening torque:
20 Nm (2.0 m·kg, 14.5 ft·lb)

Fuel line

Check the fuel hoses and vacuum lines for cracks or damage; replace if necessary.

Over flow chamber

If gasoline begin to show up in the pipe "A", loosen the three screws from over flow chamber and completely drain gasoline from the pipe "A" and chamber.

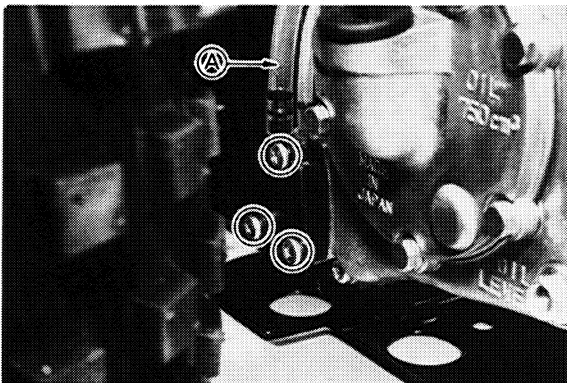

Idle speed

1. Turn the pilot air screw until it lightly seats, then back it out to specification. This adjustment can be made with engine stopped.

Air screw (Turns out): 1 and 1/4

2. Start the engine and let it warm up.
3. Throttle stop screw
Turn throttle stop screw in or out to achieve smooth engine operation at specified idle speed.

Idling speed: 1,600 ± 50 r/min

NOTE:

The pilot air and throttle stop screws are separate adjustments but they must be adjusted at the same time to achieve optimum operating condition at engine idle speeds.

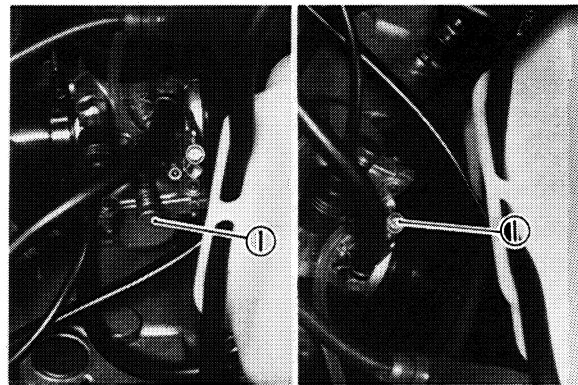

1. Throttle stop screw

2. Pilot air screw

Throttle cable

Loosen cable adjuster lock nut (at top of carburetor) and turn cable adjuster until specified free play is obtained. Retighten lock nut.

Free play: 1 ~ 1.5 mm (0.04 ~ 0.06 in)

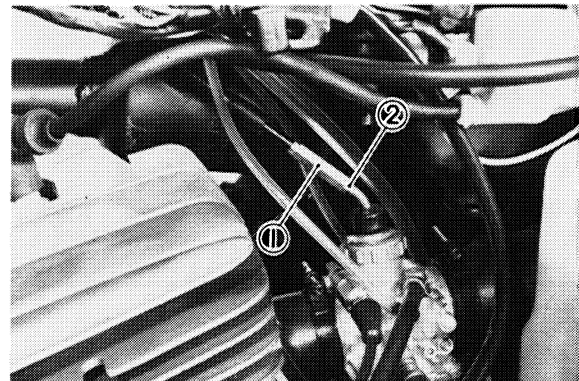

1. Adjuster

2. Lock nut

Throttle lever

Loosen the lock nut and turn the adjuster until there is the specified free play at throttle lever.

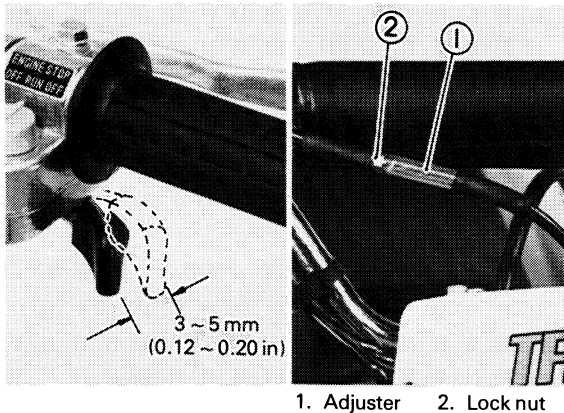

Throttle lever play:

3 ~ 5 mm (0.12 ~ 0.2 in)

Autolube pump cable adjustment

Before adjusting the pump cable, adjust the throttle cable free play.

1. Adjust the throttle cable free play of 1 ~ 1.5 mm (0.04 ~ 0.06 in) at the cable adjuster on the carburetor.
2. Close the throttle lever completely, then check to see that the Autolube pump plunger pin is aligned with the mark on the Autolube pump pulley.

Match mark: O

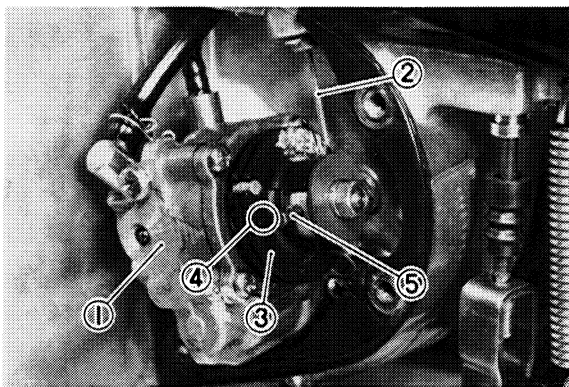

3. If the mark and pin are not in alignment, loosen the cable length adjuster lock nut on top of crankcase cover and adjust cable length until alignment is achieved.
4. Tighten adjuster lock nut.

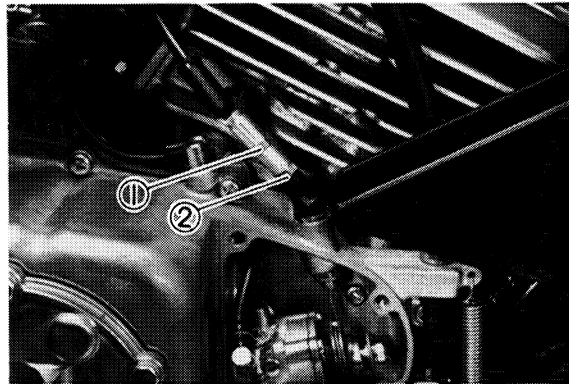

Minimum pump stroke check and adjustment

1. While running the engine idle, observe the pump adjust plate carefully, and stop the engine the moment that the adjust plate moves out to the limit.
2. Measure the gap with the thickness gauge between the raised boss on the pump adjust pulley and the adjust plate.

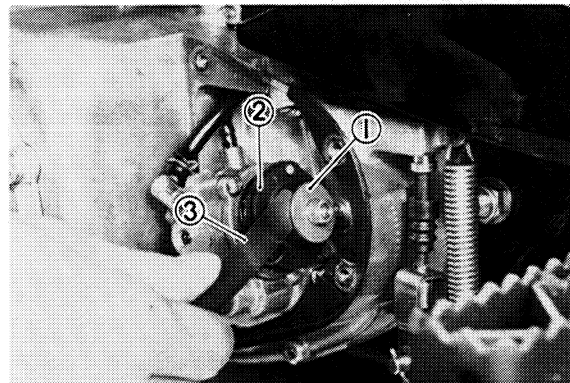

3. Repeat steps a. and b. above a few times. When the gap measured is the largest, the pump stroke is considered to be at a minimum.

NOTE: _____

When inserting the thickness gauge between the adjusting plate and the adjusting pulley, be careful so that either the plate or the pulley is not moved. In other words, do not force the thickness gauge into the gap.

Minimum pump stroke:
0.20 ~ 0.25 mm (0.008 ~ 0.010 in)

4. If clearance is not correct, remove the adjust plate lock nut and the adjust plate.
5. Remove or add an adjust shim as required.

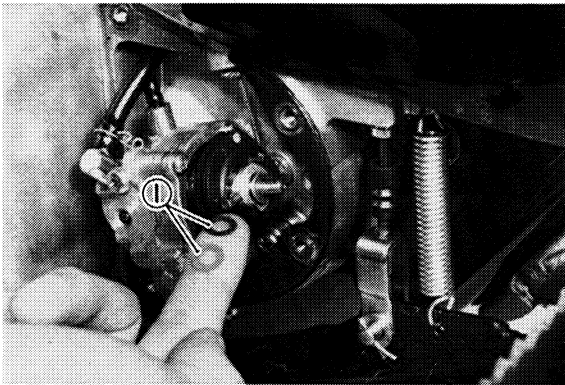

1. Adjust shim

NOTE: _____

Thicken shims increase pump stroke and output, thinner shims decrease pump stroke and output.

Air bleeding

The Autolube Pump and delivery lines must be bled on the following occasions:

- Whenever the Autolube tank has run dry.
- Whenever any portion of the Autolube system is disconnected.
- If the machine lies on its side after falling over.

1. Remove the pump cover and remove the bleed screw.

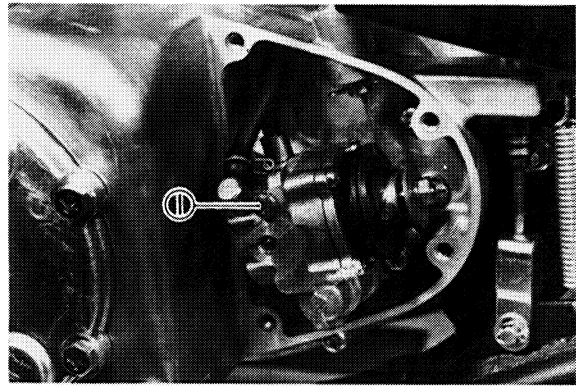

1. Bleed screw

2. Keep the oil running out until air bubbles disappear.

NOTE: _____

Check the bleed screw gasket, and if damaged, replace with a new one.

3. When air bubbles are expelled completely, tighten the bleed screw and install the pump cover.
4. Start the engine, pull the pump wire all the way out to set the pump stroke to a maximum.

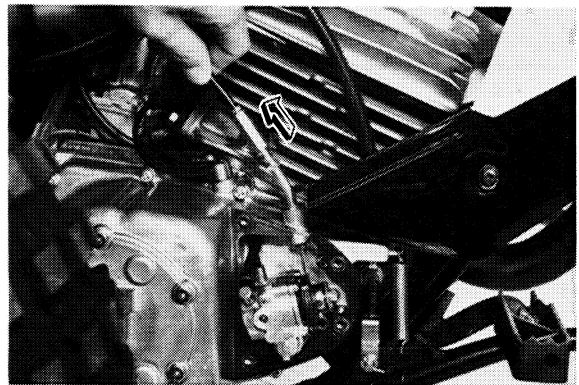

NOTE: _____

It is difficult to bleed the distributor completely with the pump stroke at a minimum, and therefore the pump stroke should be set to a maximum.

5. Keep the engine running at about 2,000 r/min for two minutes or so, and both distributor and delivery pipe can be completely bled.

Engine oil

1. Place the machine on a level place and start the engine.

Engine oil:

Yamalube 2-cycle oil or
Air-cooled 2-stroke engine oil

Oil tank capacity:

1.3 L (1.1 Imp qt, 1.4 US qt)

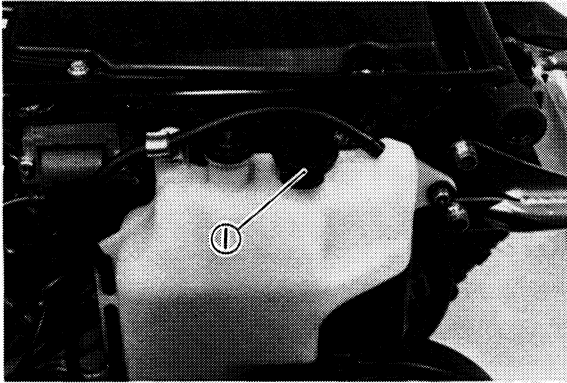

1. Oil tank filler cap

NOTE:

Install the oil tank filler cap and push it fully into the filler.

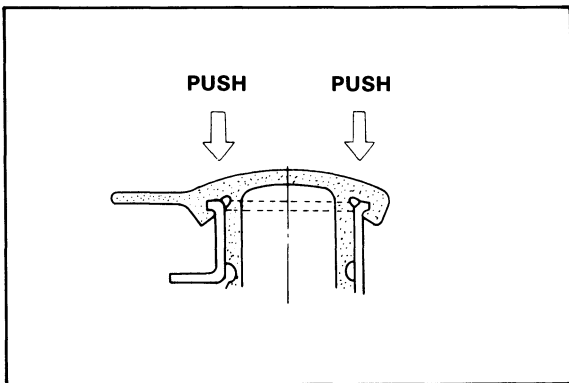

2. Oil warning indicator light
When the engine oil level is proper:
The oil warning light keeps going on about 15 seconds (under high temperatures) ~ 40 seconds (under low temperatures) after the engine has started, and then goes off.
When the engine oil level is low:
The light keeps going on after the engine has started.
If the light bulb is burnt out:
The light will not come on after the engine has started.

Checking the water release valve

Before starting off, be sure to check that the valve is closed. Before cleaning the air cleaner element, check if there is impurities in the element case.

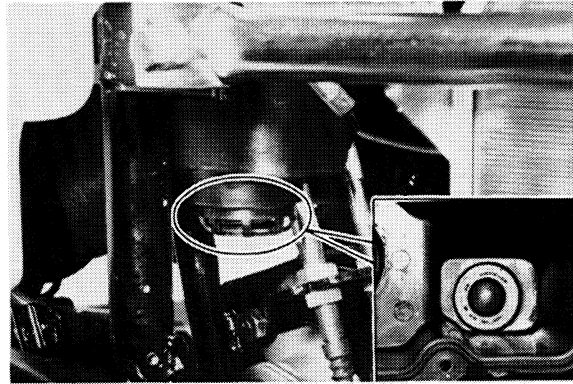

Transmission oil

Recommended oil:

Yamalube 4-cycle oil or
SAE 10W30 SE motor oil

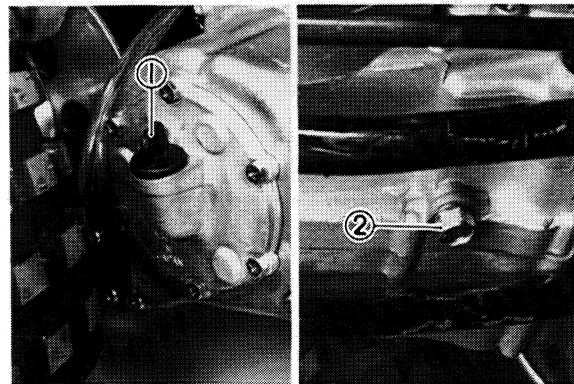

1. Filler cap

2. Drain plug

Transmission oil capacity:

Periodic oil change: 0.7 ~ 0.8 L
(0.6 ~ 0.7 Imp qt, 0.7 ~ 0.8 US qt)

Total: 0.8 ~ 0.9 L

(0.7 ~ 0.8 Imp qt, 0.8 ~ 1.0 US qt)

Transmission drain plug torque:

20 Nm (2.0 m · kg, 14.5 ft · lb)

1. To check, warm up the engine for 2 ~ 3 minutes. Place the machine upright and remove the oil level checking bolt. If oil flows out, the oil level is correct. The transmission oil should be drained and refilled every 6 months.

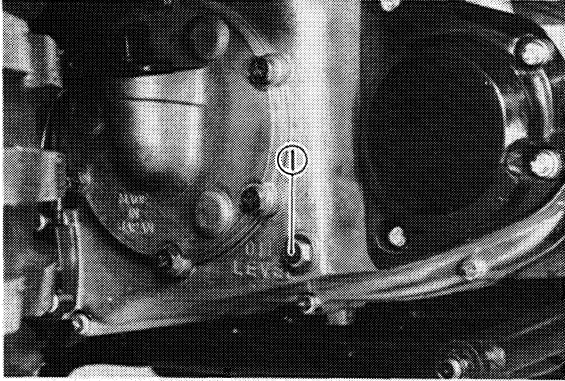

1. Checking bolt

5. While running the engine at the specified speed, check to see that the stationary pointer is aligned with the magneto center mark. If the marks are out of alignment, check the woodruff key for damage and/or crankshaft for damage.

Checking ignition timing

1. Ignition timing is checked with timing light by observing the position of the stationary pointer marked on the crankcase and the marks on the flywheel magneto.

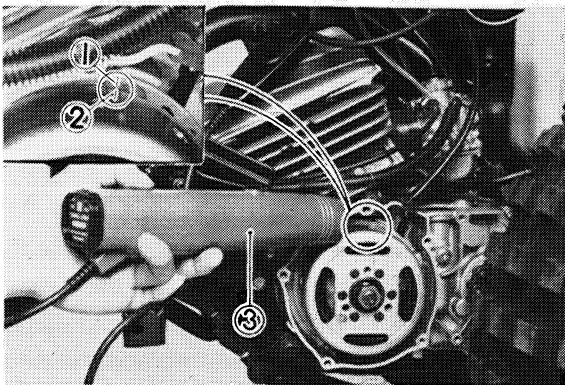

1. Mark 2. Stationary pointer 3. Timing light

2. Remove the crankcase cover (L).
3. Connect the timing light to the spark plug lead wire.
4. Start the engine and keep it running at the specified speed. Use a tachometer for checking.

Specified engine speed: $1,600 \pm 50$ r/min

CHASSIS

Air cleaner

1. Remove the air cleaner case cap and element assembly.

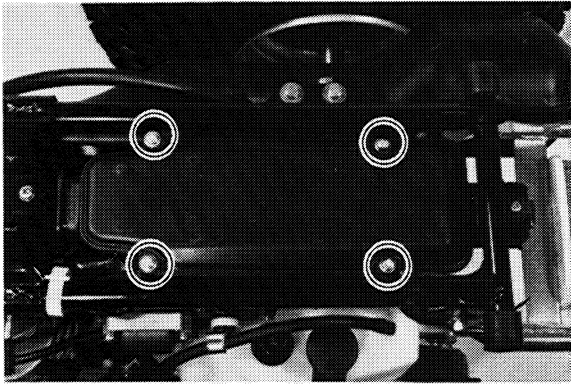

2. Wash the element gently, but thoroughly, in solvent.
3. Squeeze excess solvent out of element and dry.
4. Pour a small quantity of motor oil (SAE 10W 30) onto cleaner element and work thoroughly into the porous foam material. Element must be damp with oil but not dripping.

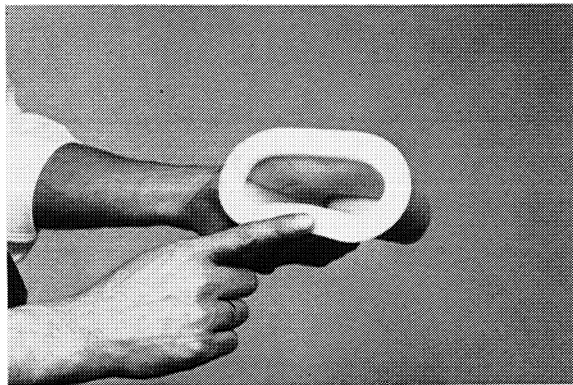

5. Re-install the element assembly and case cover.

NOTE:

Each time cleaner element maintenance is performed, check the air inlet to the cleaner case of obstructions. Check the air cleaner joint rubber to the carburetor and manifold fittings for an air-tight seal. Tighten all fittings thoroughly to avoid the possibility of unfiltered air entering the engine.

CAUTION:

Never operate the engine with the air cleaner element removed.

This will allow unfiltered air to enter, causing rapid wear and possible engine damage. Additionally, operation without the cleaner element will affect carburetor jetting with subsequent poor performance and possible engine overheating.

Front brake shoe inspection

To check, examine the wear indicator position while depressing the brake pedal. If the indicator reaches to the wear limit line, replace the shoes.

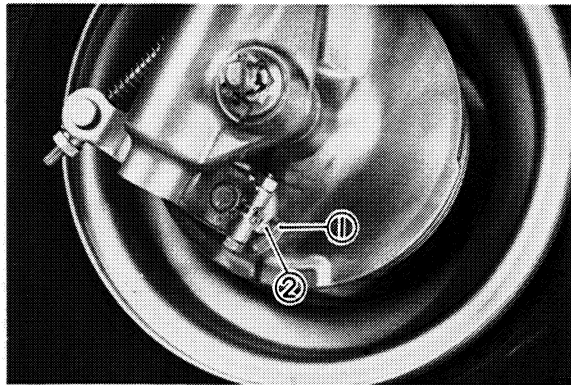

1. Wear limit 2. Wear indicator

Rear brake pad inspection

Check to see that the brake operates correctly. Remove the disc cover, check the brake pads for damage and wear. If the thickness is less than the specified value, replace the pad as a set.

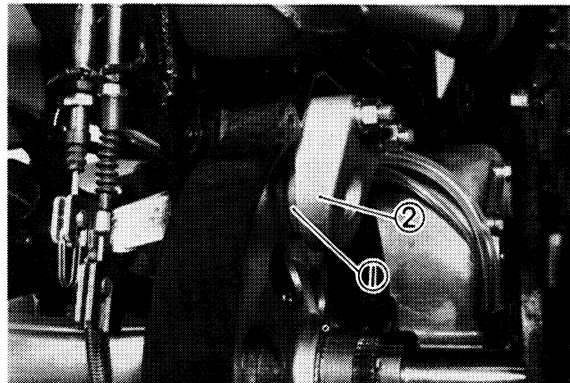

1. Brake pad 2. Caliper body

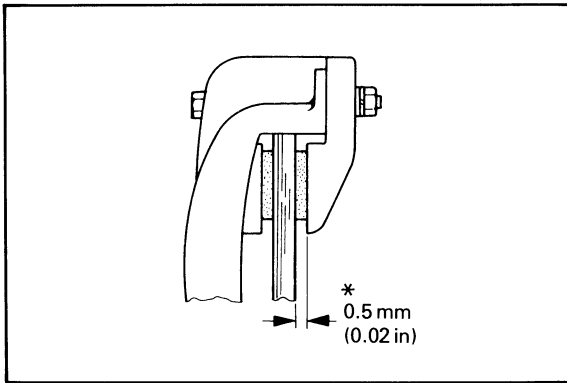

* This figure shows the wear limit of the pads as they are installed in the caliper.

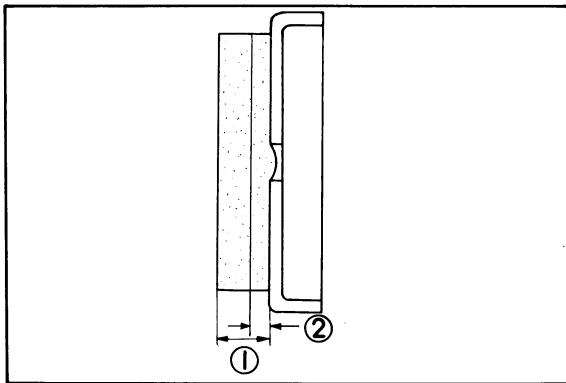

1. Pad thickness 2. Wear limit

Wear limit: 1.5 mm (0.06 in)

Brake adjustment

1. Front brake lever

Front brake cable free play can be adjusted to suit rider preference, but a minimum free play of 9 ~ 15 mm (0.35 ~ 0.59 in) should be maintained.

Free play can be adjusted at handle bar lever and brake shoe plate.

- a. Loosen the lock nut on the brake lever holder, fully turn the adjuster in.
- b. Turn the adjuster on the shoe plate in or out until proper adjustment is achieved.
- c. Unless the shoe plate adjuster helps bring a proper play, turn to the lever holder adjuster.
- d. Tighten the lock nut.

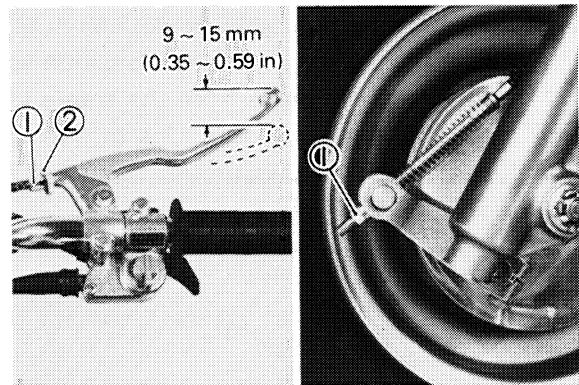

1. Adjuster 2. Lock nut

2. Brake pedal

WARNING:

When adjusting the rear brake, first adjust the brake caliper, adjust the brake pedal, then adjust the brake lever.

- a. Loosen the brake lever lock nut and screw in the adjuster until tight.

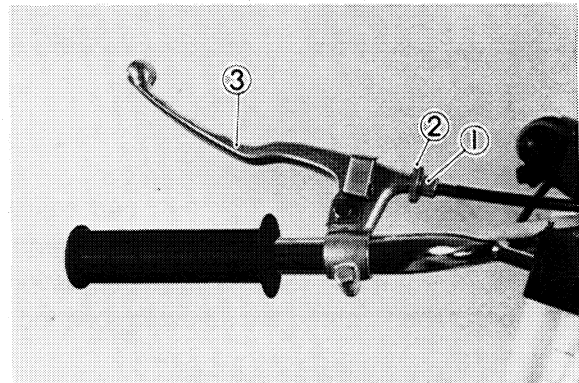

1. Adjuster
2. Lock nut
3. Brake lever (1)

- b. Loosen the brake pedal cable lock nuts, adjust the brake caliper lever position so that the cable length from the frame to the cable end is 62 mm (2.4 in), as illustrated. After adjustment, tighten the lock nuts.

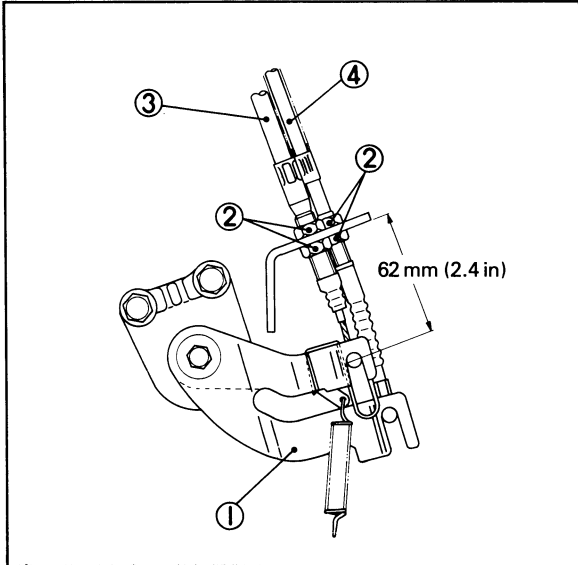

1. Brake caliper lever
2. Lock nut
3. Brake pedal cable
4. Rear brake cable

- c. Loosen the caliper lock nut, and adjust the play of the brake pedal to 6 ~ 10 mm (0.24 ~ 0.39 in) by turning the adjusting bolt. Then tighten the adjusting bolt lock nut.

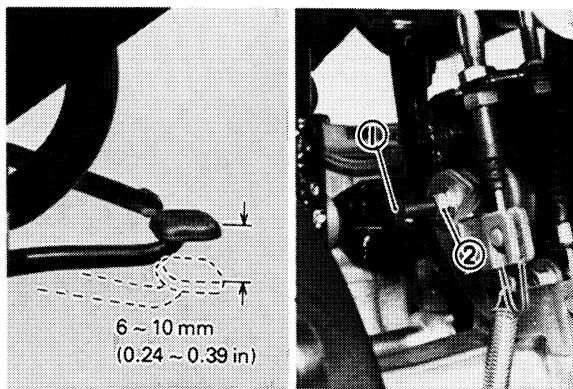

1. Adjusting bolt
2. Lock nut

Tightening torque:
15 Nm (1.5 m·kg, 11 ft·lb)

3. Rear brake lever

WARNING:

Never adjust the brake lever without first adjusting the brake caliper and brake pedal.

- a. Loosen the brake cable lock nuts and turn the adjuster so that the rear brake cable and brake caliper lever have no play at all. After adjusting, tighten the lock nuts.

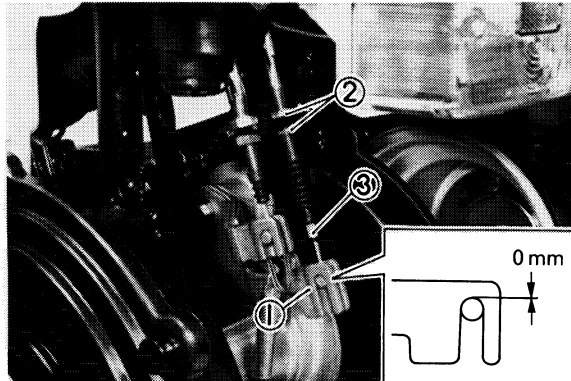

1. Brake caliper lever
2. Lock nut
3. Rear brake cable

- b. Turn the adjuster so that the brake lever has a play of 9 ~ 15 mm (0.35 ~ 0.59 in) at its end. Next, tighten the lock nut.

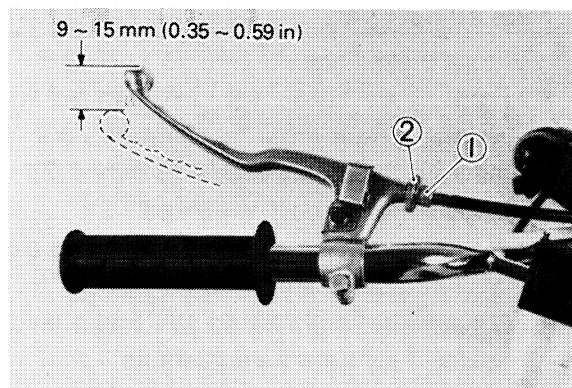

1. Adjuster
2. Lock nut

Drive chain tension check

Inspect the drive chain with both tires touching the ground. Check the tension at the position shown in the illustration. The normal vertical deflection is approximately 5 ~ 10 mm (0.2 ~ 0.4 in). If the deflection exceeds 10 mm (0.4 in), adjust the chain tension.

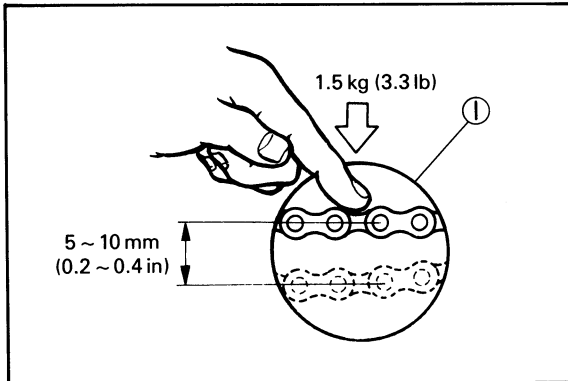

1. Inspection window

Drive chain tension adjustment

1. Loosen the rear wheel hub bolts.

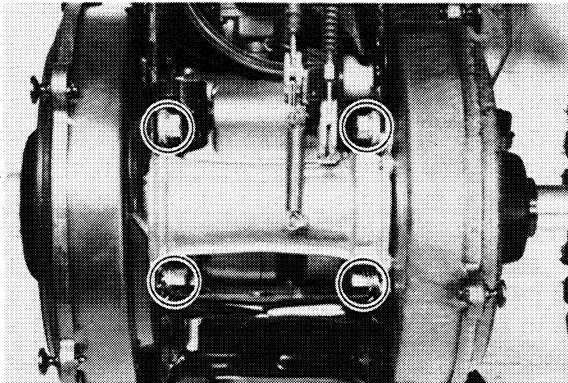

2. Next, adjust chain play to specification by turning the chain puller adjuster.

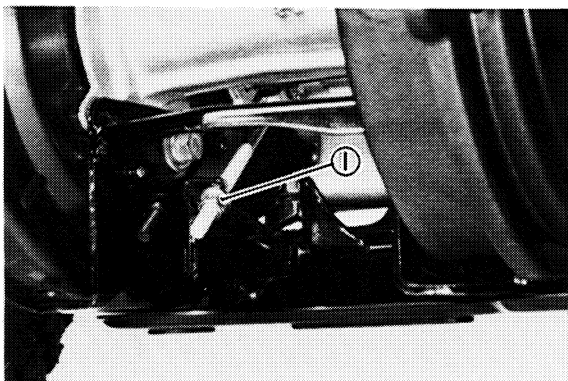

1. Adjuster

3. Tighten the rear wheel hub bolts.

Tightening torque:

46 Nm (4.6 m · kg, 33 ft · lb)

Drive chain cleaning and lubrication

This machine has a drive chain with small rubber O-rings between the chain plates. Steam cleaning, high-pressure washes, and certain solvent can damage these O-rings. Use only kerosene to clean the drive chain. Wipe it dry, and thoroughly lubricate it with SAE 30 ~ 50 motor oil. Do not use any other lubricants on the drive chain. They may contain solvents that could damage the O-rings.

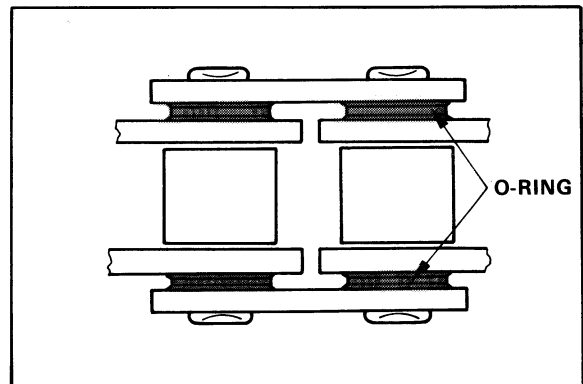

Steering head adjustment

The steering assembly should be checked periodically for looseness.

1. Raise the front end of the machine so that there is no weight on the front wheel.
2. Grasp the bottom of the forks and gently rock the fork assembly backward and forward, checking for looseness in the steering assembly bearings.

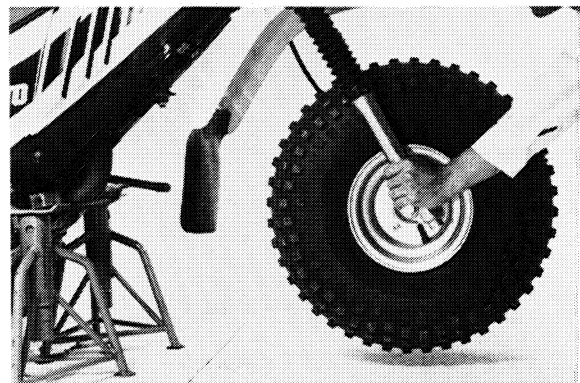

- If the steering head is loose, adjust it. Remove the handlebar holder bolts, handlebar, breather pipe, cap bolts, steering stem nut, and steering crown.
- Use a steering nut wrench to tighten the steering fitting nut until the steering head is tight but does not bind when the forks are turned.

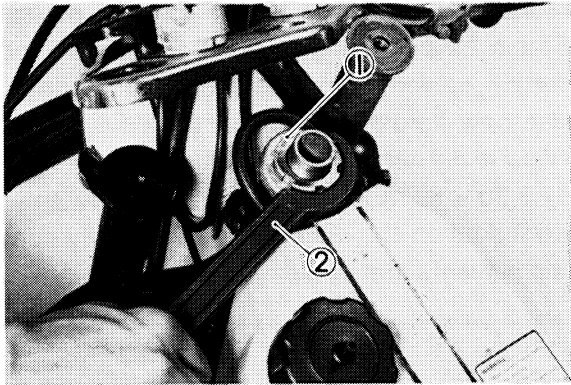

- Steering fitting nut
- Steering nut wrench

- Install the steering crown and retighten the stem nut, cap bolts handlebar, and handlebar holder bolts in that order.

Tightening torque:

Steering stem nut:

65 Nm (6.5 m · kg, 47 ft · lb)

Cap bolt:

54 Nm (5.4 m · kg, 39 ft · lb)

Handlebar holder bolt:

34 Nm (3.4 m · kg, 24.5 ft · lb)

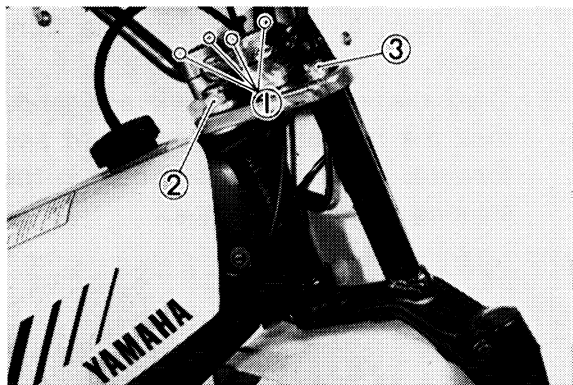

- Handlebar holder bolt
- Steering stem nut
- Cap bolt

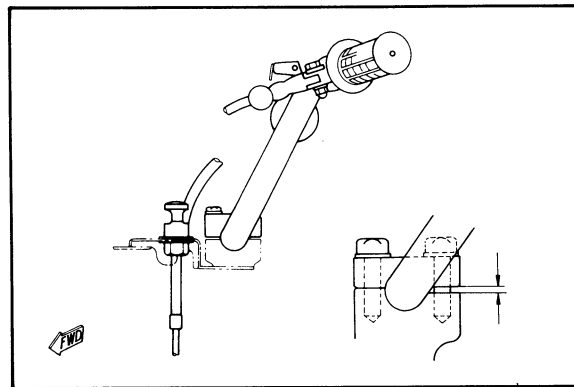

- Recheck steering adjustment to make sure there is no binding when the forks are moved from lock to lock. If necessary, repeat the adjustment procedure.

Wheel bearings

If a rolling rumble is noticed and increases with increasing wheel speed (not engine or transmission speed), the wheel bearings may be worn. Check the wheel bearings for both the front and rear wheels.

Front wheel

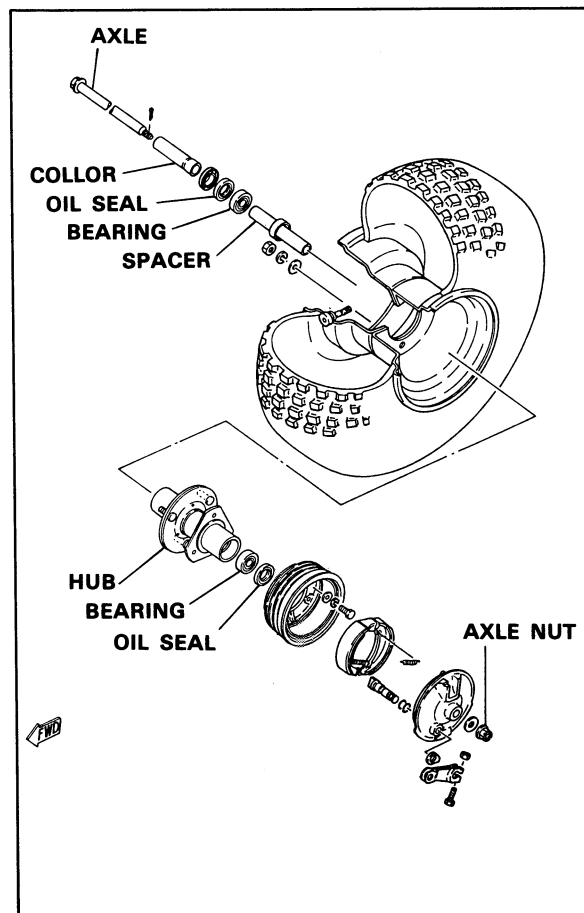

Rear wheel

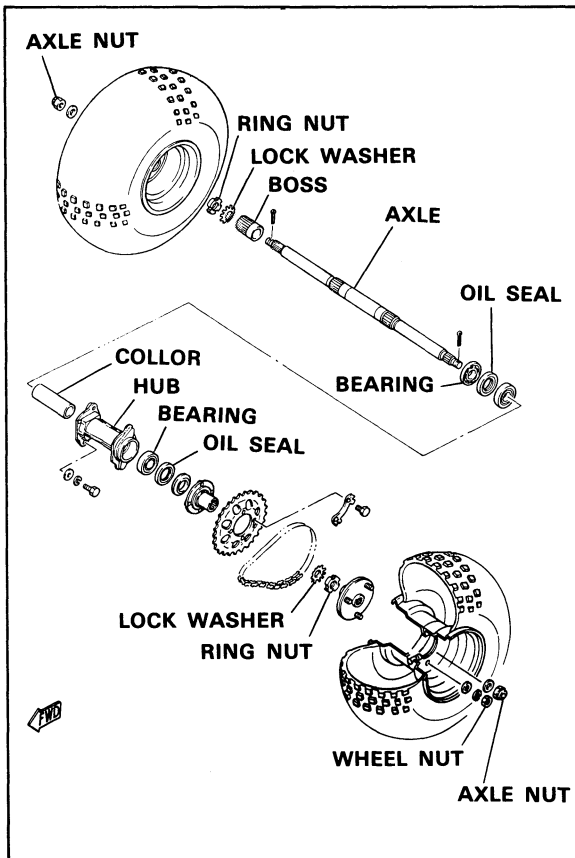

Fuel cock

If either fuel cock is leaking or is excessively contaminated, it should be removed from the fuel tank and inspected.

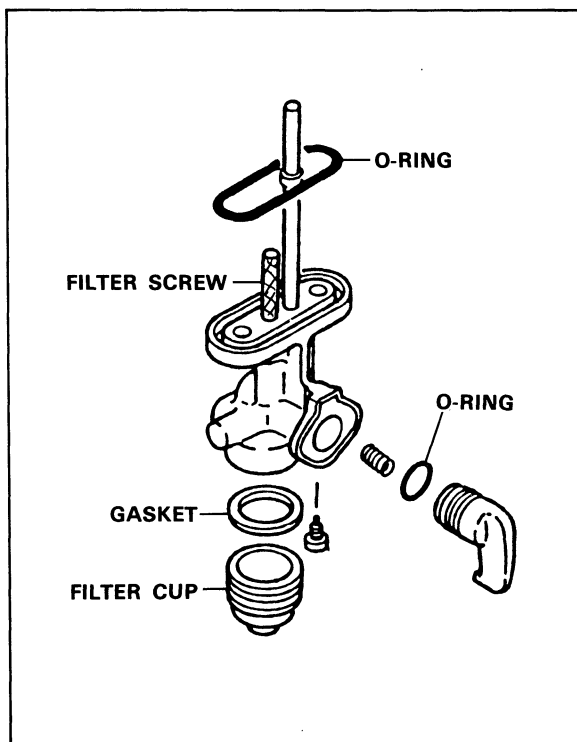

1. Remove the fuel tank and position it so that fuel will not spill when the fuel cock is removed.
2. Remove the fuel cock and inspect the filter screen. Replace the filter if it is seriously contaminated.
3. Remove the screws on the front and rear of the fuel cock; remove the plate, gaskets, lever, and diaphragm.
4. Inspect all components, and replace any that are damaged. If the diaphragm is damaged in any way or if the fuel cock gasket surfaces are scratched or corroded, the fuel cock assembly must be replaced. If there is abrasive damage to any components, the fuel tank must be drained and flushed.
5. Reassemble the fuel cock, and install it on the fuel tank.

Tires

WARNING:

This model is equipped with low pressure tires. Pay attention to the following points:

Recommended tire pressure:

14.7 kPa (0.15 kg/cm², 2.2 psi)

Vehicle load limit: 100 kg (220 lb)

Tire size: 22 × 11-8

1. Excessive tire pressure (over 68.6 kPa (0.7 kg/cm², 10 psi) may cause tire to burst. Inflate tires very slowly. Fast inflation could cause tire to burst.
2. Too low a pressure (below 11.8 kPa (0.12 kg/cm², 1.8 psi)) will cause the rim to dislodge from the tire.
3. Put the same pressure in both rear tires. Uneven tire pressure will severely affect the handling.
4. Set tire pressures cold.

Resistance to pressure:

68.6 kPa (0.7 kg/cm², 10 psi)

Reference tire pressure:

14.7 kPa (0.15 kg/cm², 2.2 psi)

Min. tire pressure:

11.8 kPa (0.12 kg/cm², 1.8 psi)

1. How to measure tire pressure
Use an inelastic but flexible narrow strip or the like to measure the circumference of the inflated tire (not including the block patterns). Adjust the tire pressure to the specified measurement. This pressure may be above specification to suit the rider's preference.

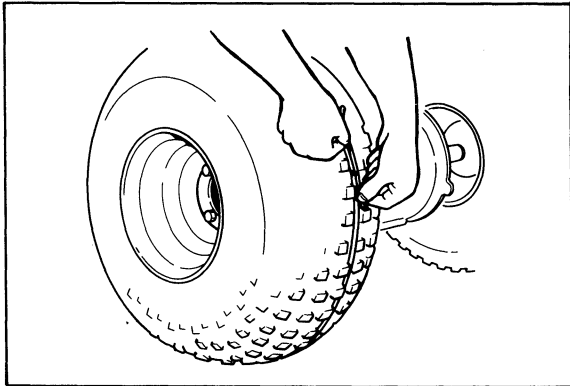

CAUTION:

Never use a tire pressure below specification, which may result in the danger of the tire being dislodged under severe operating conditions.

Standard tire circumference:
1,735 mm (68.3 in)
Minimum tire circumference:
1,725 mm (67.9 in)

Cable inspection and lubrication

1. Damage to the outer housing of the various cables may cause corrosion. Often free movement will be obstructed. An unsafe condition may result. Replace such cables as soon as possible.
2. If the inner cables do not operate smoothly, lubricate or replace them.

Recommended lubricant:
Yamaha Chain and Cable Lube or
10W30 motor oil

Brake and change pedals/front and rear brake levers

Lubricate the pivoting parts of each lever and pedal.

Recommended lubricant:
Yamaha Chain and Cable Lube or
10W30 motor oil

ELECTRICAL

Headlight bulb replacement

1. Remove the front panel and headlight unit assembly.

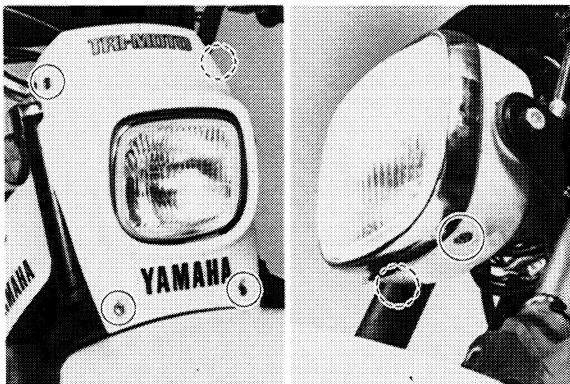

2. Turn the bulb holder counterclockwise and remove the defective bulb.

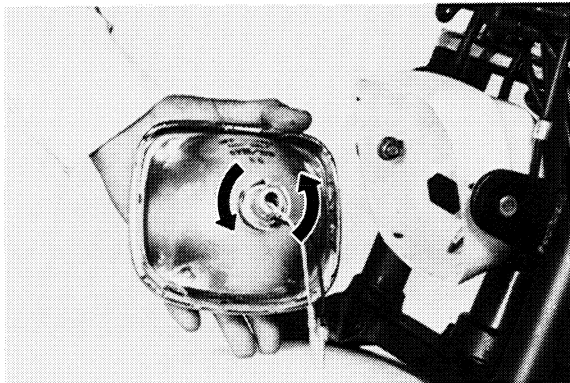

3. Slip a new bulb into position and secure it with the bulb holder.
4. Reinstall the light unit assembly to the headlight body. Adjust the headlight beam if necessary.
5. Reinstall the front panel.

Headlight beam adjustment

When necessary, adjust the headlight beam as follows:

1. Remove the front panel.
2. Adjust vertically by moving the headlight body.

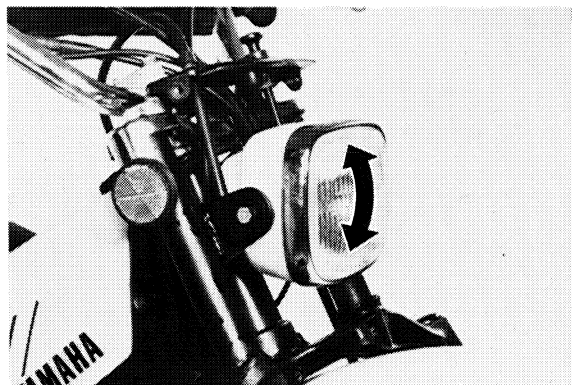

3. Reinstall the front panel.

CHAPTER 3. ENGINE OVERHAUL

ENGINE REMOVAL	3-1
Preparation for removal	3-1
Exhaust	3-1
Wiring and cables	3-1
Carburetor	3-2
Flywheel magneto	3-2
Change pedal	3-3
Drive chain	3-3
Removal	3-3
ENGINE DISASSEMBLY	3-3
Reed valve assembly	3-3
Cylinder head and cylinder	3-3
Piston pin and piston	3-4
Crankcase cover, right	3-4
Clutch assembly and primary drive gear	3-4
Change shaft assembly	3-6
Drive sprocket	3-6
Crankcase	3-6
Transmission and shifter	3-6
Crankshaft	3-7
INSPECTION AND REPAIR	3-7
Cylinder head	3-7
Cylinder	3-7
Piston pin and bearing	3-8
Piston	3-8
Piston rings	3-9
Autolube pump	3-9
Starter	3-10
Clutch	3-11
Primary drive	3-14
Change shaft and change levers	3-14
Transmission	3-14
Crankshaft	3-15
Bearings and oil seals	3-15
Crankcase	3-15

ENGINE ASSEMBLING AND ADJUSTMENT	3-16
Important information	3-16
Crankshaft installation	3-16
Transmission and shifter installation	3-17
Crankcase	3-19
Change shaft assembly	3-19
Primary drive gear and clutch assembly	3-19
Crankcase cover (right)	3-19
Piston	3-19
Cylinder	3-20
Cylinder head	3-20
Reed valve	3-20
MOUNTING	3-21

ENGINE OVERHAUL

ENGINE REMOVAL

Preparation for removal

1. Always clean engine before removal. Do not begin work until all proper tools are available. As parts are removed, clean them and place them in trays in order of disassembly.
2. Start the engine and warm it for a few minutes. Turn off and drain transmission oil. Before beginning of the servicing, fully cool the engine down.

Exhaust

1. Remove the seat and rear fender.
2. Remove the side cover assembly.



3. Remove exhaust pipe assembly.

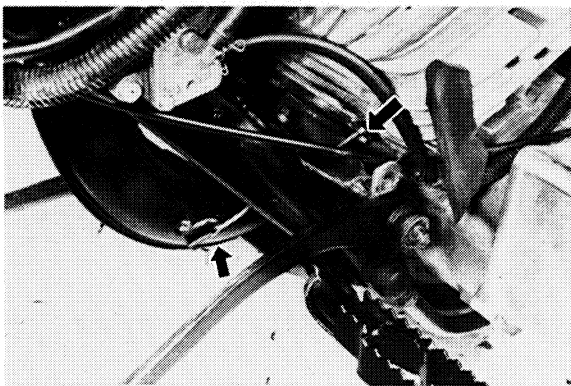

Wiring and cables

1. Remove the spark plug cap, oil pump cover, pump cable and oil pipe.

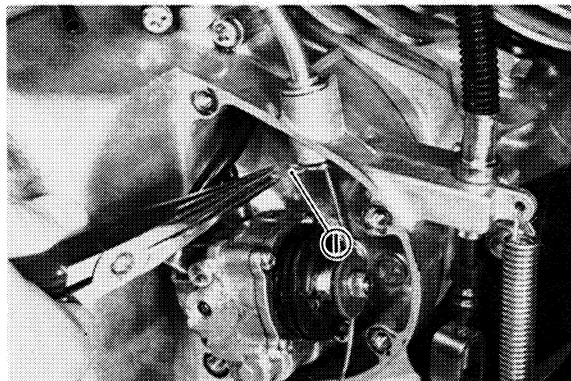

1. Clip

NOTE:

Do not leave the oil pipe disconnected from the oil pump, or oil will flow out of the oil tank. It is advisable to plug the open pipe end with a proper size screw.

2. Remove the rear brake wire and spring from rear brake pedal.

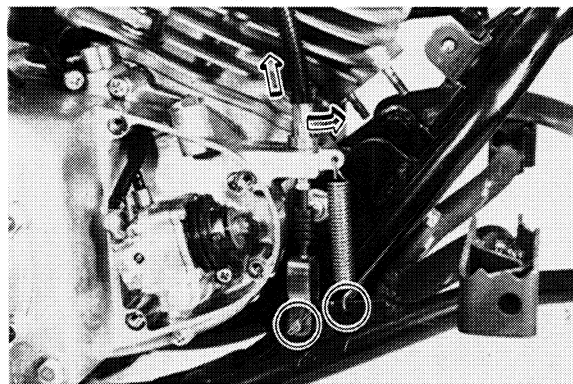

3. Remove the air bleed pipes from crankcase.
4. Remove the starter wire, air vent pipes, overflow pipe, pulser pipe, and fuel pipe from carburetor.

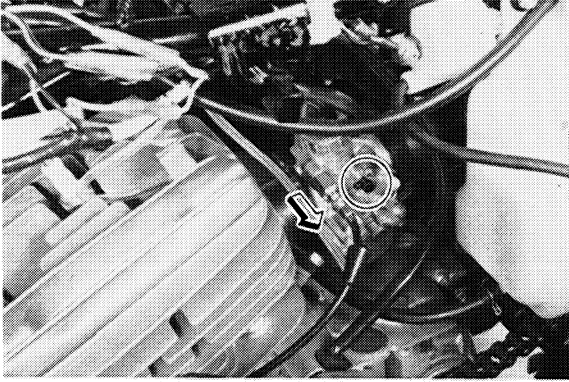

5. Disconnect the magneto lead wire.

Carburetor

1. Loosen clamps on each end of the carburetor.
2. Remove the carburetor.

Flywheel magneto

1. Remove the starter assembly.

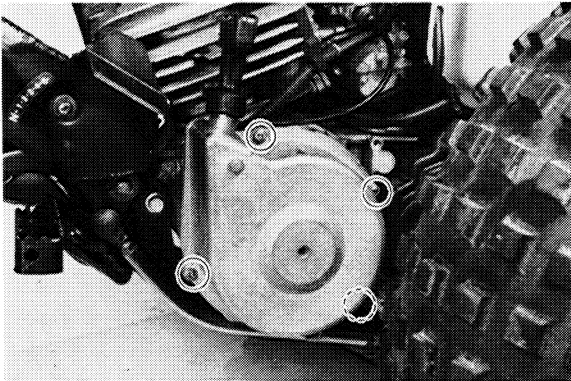

2. Remove the starter pulley.

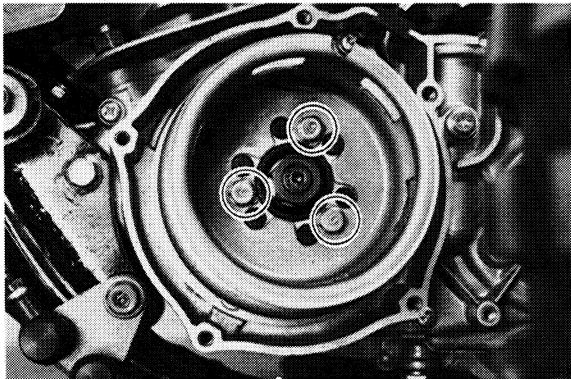

3. Remove the flywheel securing nut. (use Flywheel holding tool)

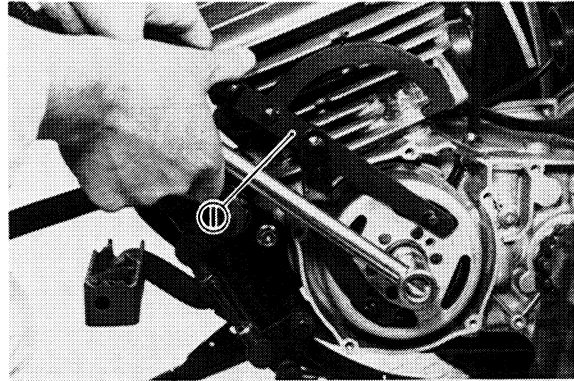

1. Flywheel holding tool

4. Install flywheel puller on flywheel and tighten it.

NOTE:

The puller body has lefthand thread.

5. While holding puller body, tighten push bolt. This will pull flywheel off the tapered end of the crankshaft.

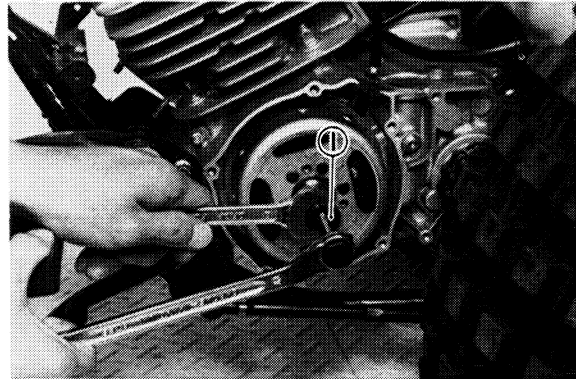

1. Flywheel puller

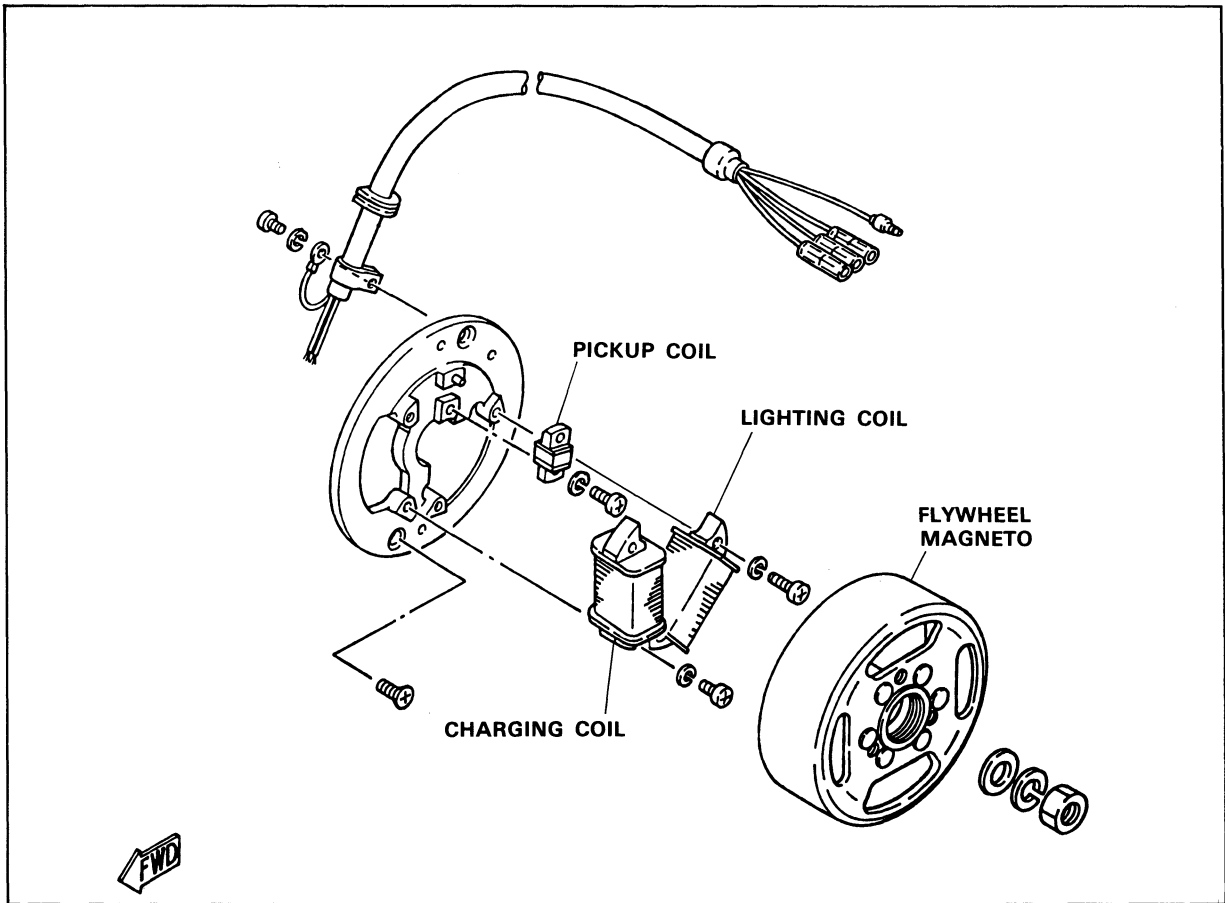

Change pedal

1. Remove the change pedal.

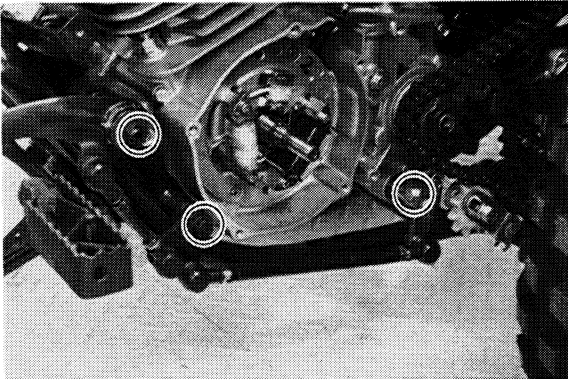

Drive chain

1. Loosen the drive sprocket lock nut, and remove the drive chain.

Removal

1. Remove the engine mounting bolts and remove engine from right side of frame.

ENGINE DISASSEMBLY

Reed valve assembly

1. Remove reed valve assembly holding bolts (4), carburetor joint and reed valve assembly.

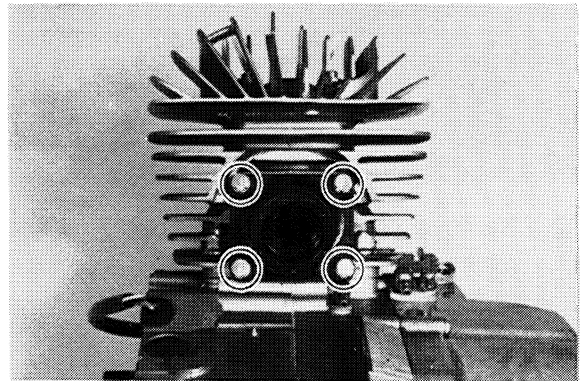

Cylinder head and cylinder

1. Remove the cylinder head holding nuts, cylinder head and head gasket.

- Remove the cylinder holding nuts, cylinder and cylinder gasket.

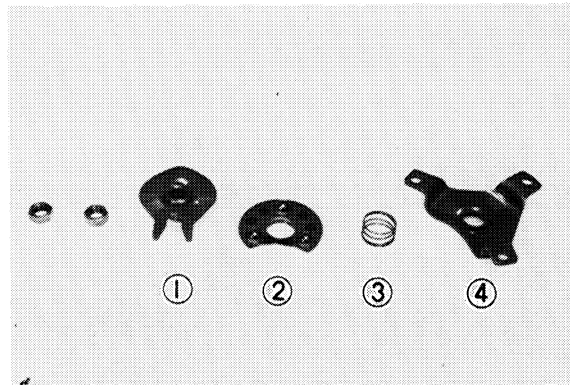
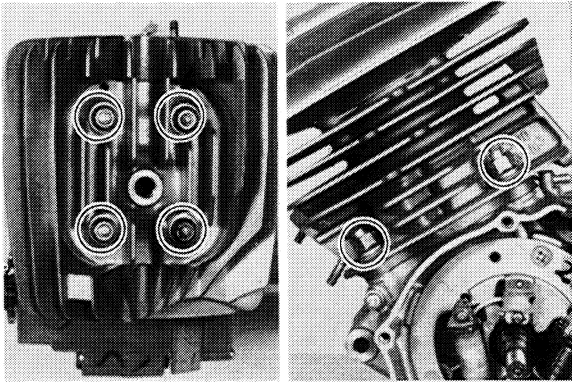

- Shift guide
- Ball holder
- Compression spring
- Guide

Piston pin and piston

- Remove one piston pin clip from piston.

NOTE:

Before removing the piston pin clip, cover the crankcase with a clean rag so you will not accidentally drop the clip into the crankcase.

- Remove the piston pin using the piston pin puller.

Crankcase cover, right

- Remove the shifter cover.

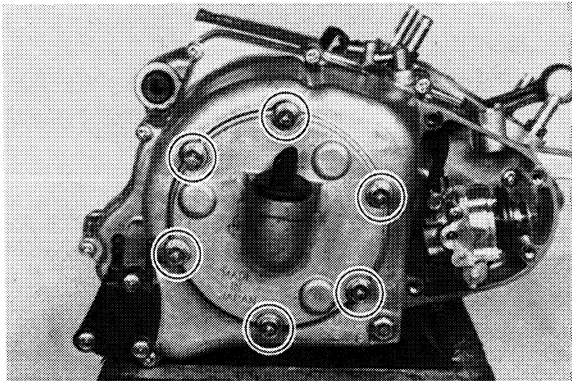

- Remove the guide from crankcase cover.

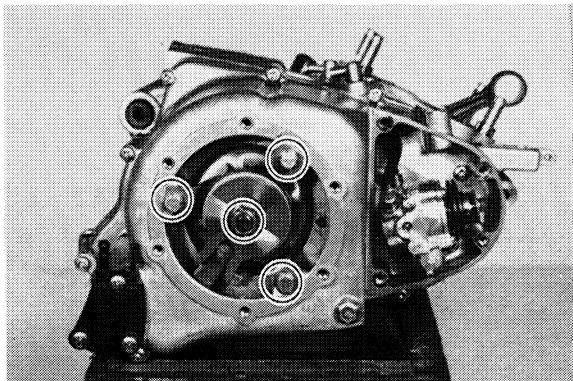

- Remove right crankcase cover screws and cover. The cover can be removed without removing the Autolube pump.

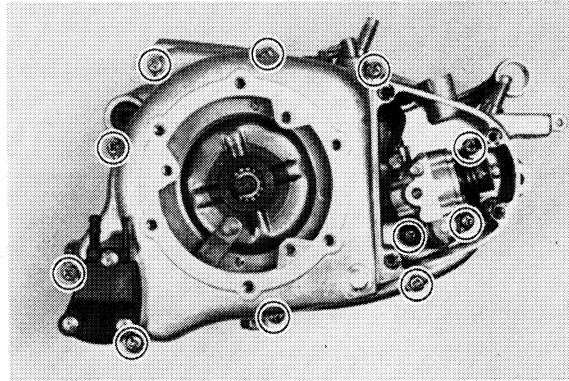

Clutch assembly and primary drive gear

- Remove the shift lever.

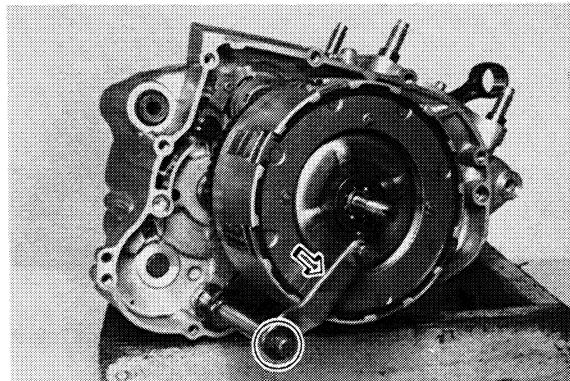

2. Remove the circlip and pressure plate.

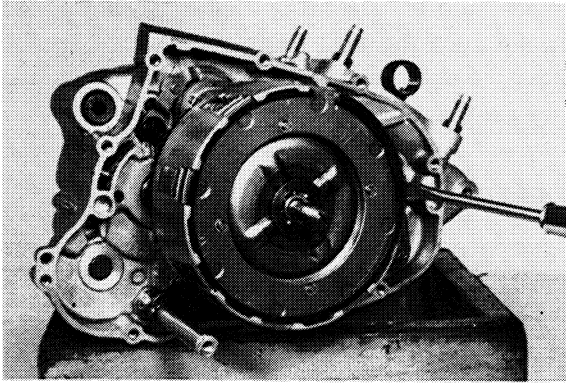

3. Remove the primary drive gear. Feed a rolled-up rag between the tooth of the primary drive gear and primary driven gear to lock them and loosen the primary drive gear lock nut.

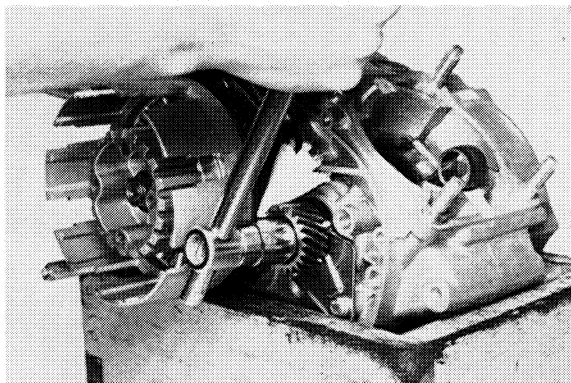

4. Using the Flywheel holding tool, remove the nut and washer. Remove the clutch boss and driven gear (clutch housing).

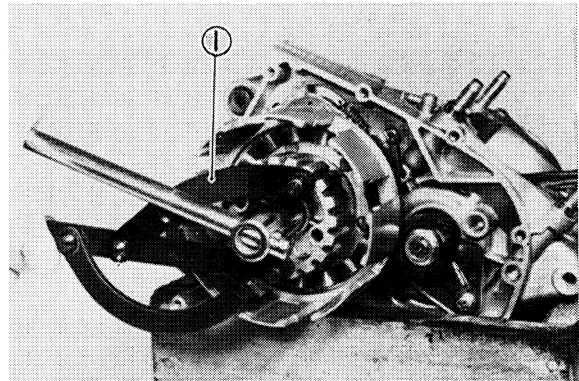

1. Flywheel holding tool

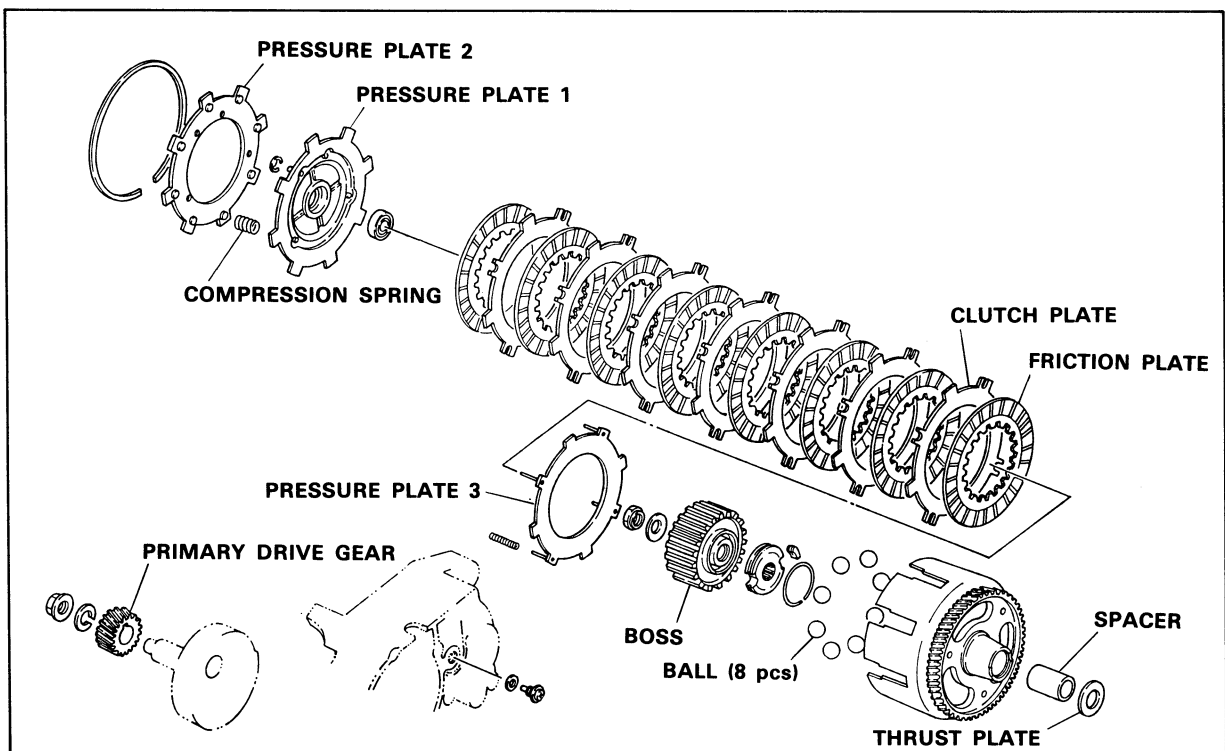

Change shaft assembly

1. Remove the change shaft assembly.
2. Remove the circlip and change lever assembly.

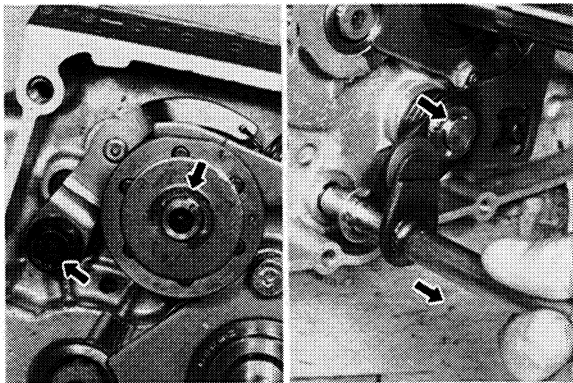

NOTE: _____
Fully tighten the tool securing bolts, but make sure the tool body is parallel with the case. If necessary, one screw may be backed out slightly to level tool body.

CAUTION: _____
Use a soft hammer to tap on the case half. Tap only on reinforced portions of case. Do not tap on gasket mating surface. Work slowly and carefully. Make sure the case halves separate evenly. If one end "hangs up", take pressure off the push screw, realign and start over. If the halves are reluctant to separate, check for a remaining case screw or fitting. Do not force.

Drive sprocket

1. Remove the drive sprocket.

Crankcase

1. Working in a crisscross pattern, loosen each screw 1/4 turn. Remove screws after all are loosened.

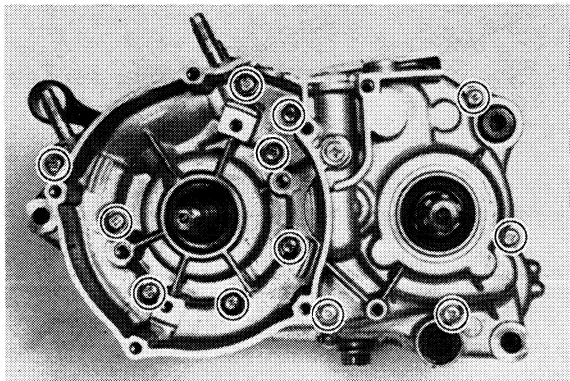

2. Install crankcase separating tool as shown.
Use a thick plain washer to protect the end of crankshaft.

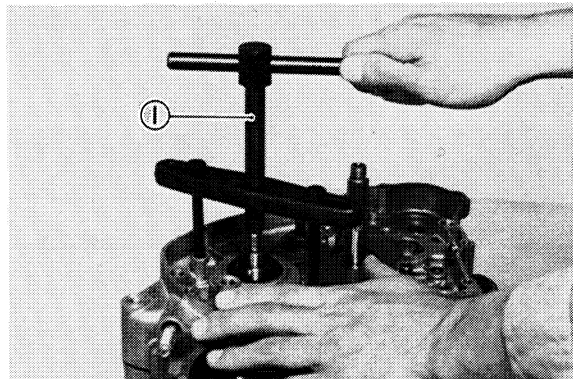

1. Crankcase separating tool

Transmission and shifter

Transmission shaft, shift forks and shift cam should be removed as an assembly. To remove, tap lightly on the transmission drive shaft with a soft hammer.

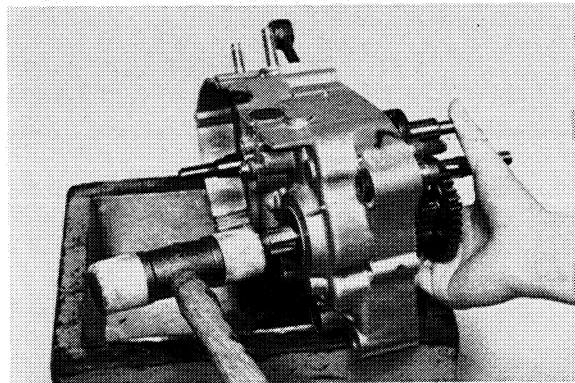

NOTE: _____
Remove assembly carefully. Note the position of each part. Pay particular attention to the location and direction of shift forks.

Crankshaft

Remove crankshaft assembly with the crankcase separating tool.

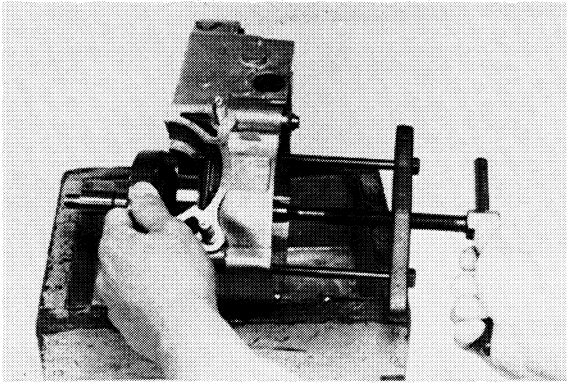

INSPECTION AND REPAIR

Cylinder head

1. Remove spark plug.
2. Using a rounded scraper, remove carbon deposits from combustion chamber. Take care to avoid damaging spark plug threads. Do not use a sharp instrument. Avoid scratching the combustion chamber surface.

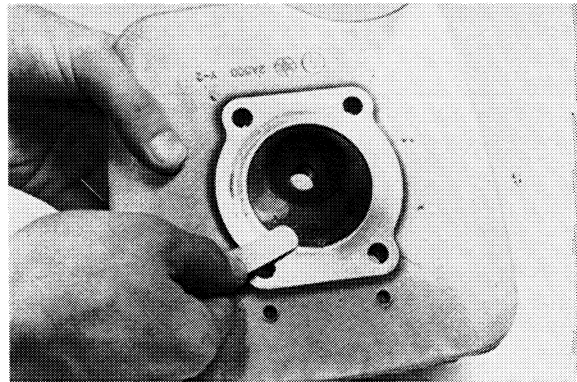

3. Place on a surface plate. There should be no warpage. Correct by re-surfacing as follows:
Place 400 ~ 600 grit wet sandpaper on surface plate and re-surface head using a figure-eight sanding pattern. Rotate head several times to avoid removing too much material from one side.

Cylinder

1. Hone cylinder bore using a hone with fine stones. Hone no more than required to remove all wear marks.
2. Using a Cylinder Gauge set to standard bore size, measure the cylinder. Measure front-to-rear and side-to-side at top, center and bottom just above exhaust port. Compare minimum and maximum measurements. If over tolerance and not correctable by honing, rebore to next over-size.

Max. allowable taper (d — a):
 0.05 mm (0.0020 in)
 Max. allowable out-of-round
 (B — A or A — B):
 0.01 mm (0.0004 in)
 Wear limit: 56.10 mm (2.21 in)
 (at "a" position)

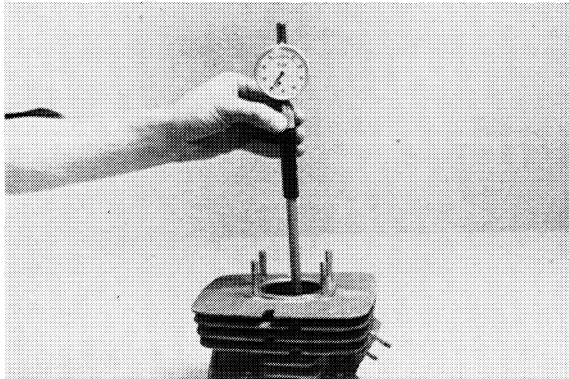
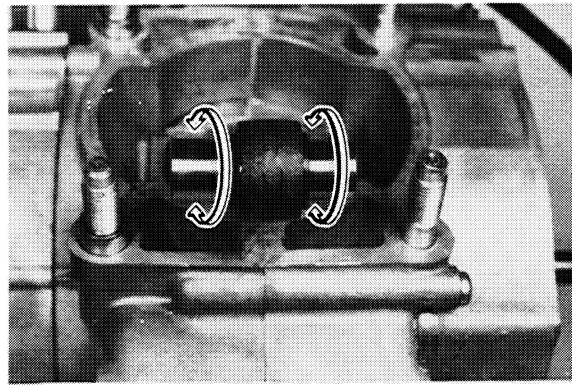

Piston

1. Remove carbon deposit from ring grooves using old piston ring as shown.
2. Using an outside micrometer, measure piston diameter. The piston is camground and tapered. The only measuring point is at right angles to the piston pin holes about 10 mm (0.39 in) from bottom of piston. Compare piston diameter to cylinder bore measurements.

Piston maximum diameter (as shown below) subtracted from minimum cylinder diameter (d — B) gives piston clearance. If beyond tolerance, hone cylinder to tolerance or re-bore to next over-size and fit over-size piston.

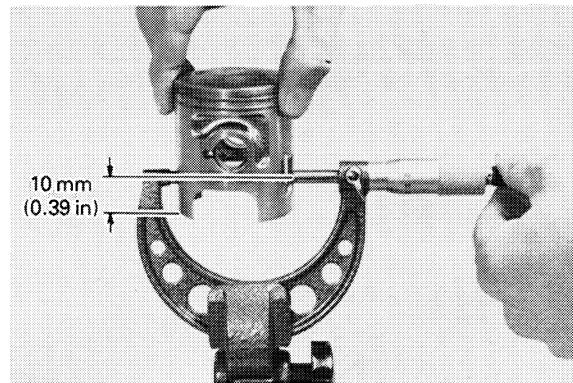
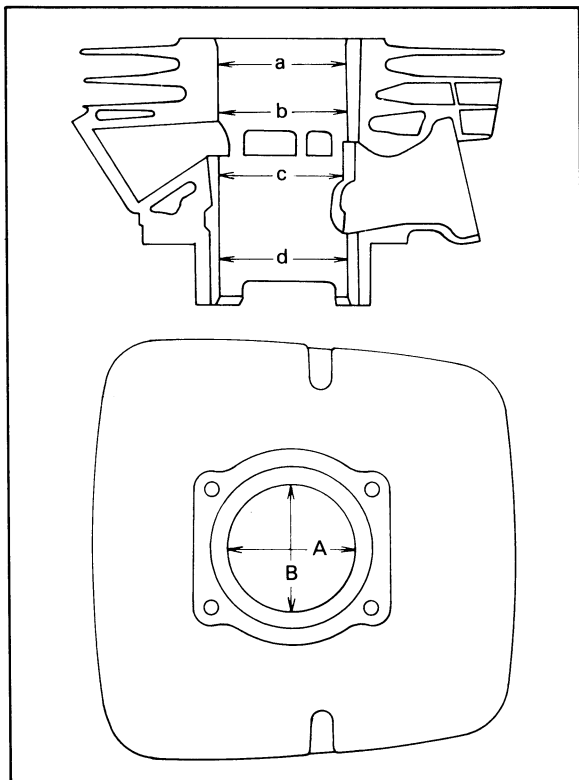

Piston pin and bearing

Apply a light film of oil to pin and bearing surfaces. Install in connecting rod small end. Check for play. There should be no noticeable vertical play. If play exists, check connecting rod small end for wear. (Replace pin and bearing or all as required.)

Piston clearance

0.040 ~ 0.045 mm
 (0.0016 ~ 0.0018 in)

Piston rings

1. Check rings for scoring. If any severe scratches are noticed, replace ring set.
2. Insert each ring into cylinder. Push down approximately 20 mm (0.79 in) using piston crown to maintain right-angle to bore. Measure installed end gap. If beyond to tolerance, replace set.

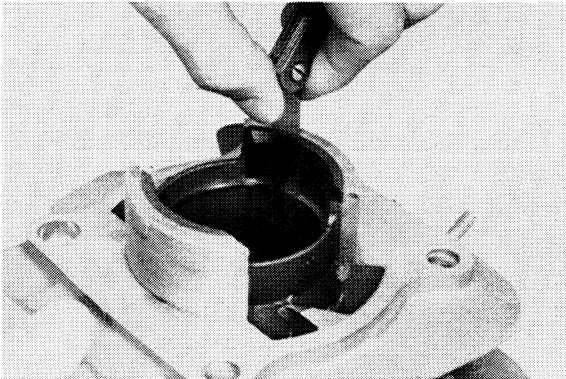

Ring end gap (installed)	
Top/ Second	0.30 ~ 0.50 mm (0.012 ~ 0.020 in)

3. With rings installed in grooves, insert feeler gauge between ring and groove. If beyond tolerance, replace ring and/or piston as required.

	Ring groove clearance
Top	0.04 ~ 0.08 mm (0.0016 ~ 0.0031 in)
Second	0.04 ~ 0.08 mm (0.0016 ~ 0.0031 in)



Autolube pump

1. Troubleshooting and repair
 - a. Wear or an internal malfunction may cause pump output to vary from the factory setting. This situation is, however, extremely rare. If output is suspected, check the following:
 - 1) Obstructions in delivery line to pump or from pump to cylinder.
 - 2) Worn or damaged pump body seal or crankcase cover seal.
 - 3) Missing or improperly installed check ball or spring.
 - 4) Improperly installed or routed oil delivery line(s).
 - 5) Loose fitting(s) allowing air to enter pump and/or engine.
 - b. If all inspections show no obvious problems and output is still suspect, connect a delivery line from the pump to a graduated container (cm³). Keep the delivery line short. If output is not to specification, replace pump assembly.

Autolube Pump Specifications:

Pump color code: Green

Pump stroke length	Minimum stroke	Maximum stroke
	0.20 ~ 0.25 mm (0.08 ~ 0.01 in)	1.85 ~ 2.05 mm (0.07 ~ 0.08 in)

Pump output at 200 strokes	Minimum output	Maximum output
	0.814 cm ³ (0.029 Imp oz, 0.028 US oz)	3.29 cm ³ (0.12 Imp oz, 0.11 US oz)

Starter

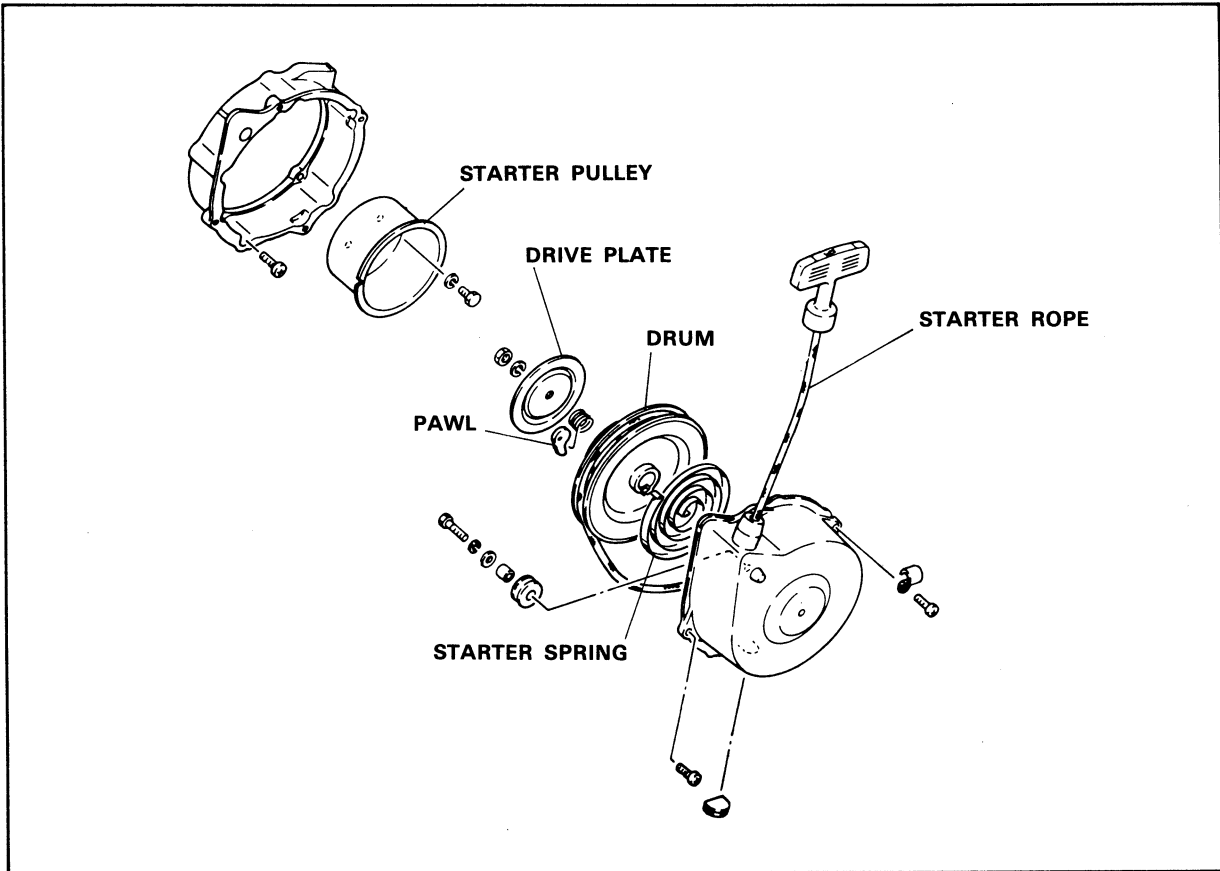

1. Install the starter spring in the starter case.

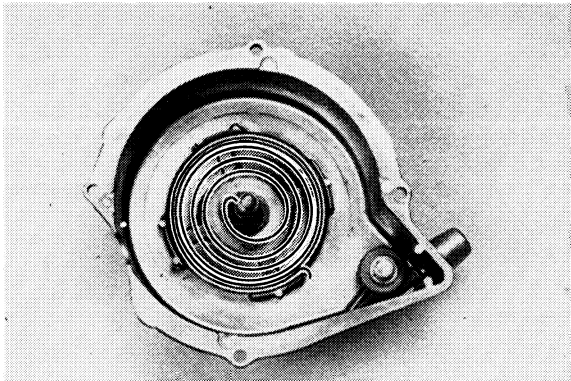

NOTE:

1. It is necessary to wind the spring to a small size before installing it in the starter case.
2. Be careful not to install the spring in the wrong way.
3. Hook the loop on the outer end of the spring onto the spring hook in the starter case. Then thoroughly grease the spring.

2. Insert the rope end to the hole in the shave drum and knot on the rope end. Wind the rope around the shave drum in the direction of the arrow and hook the rope in the cut on the shave drum periphery 370 mm (14.6 in) from the end of the rope.

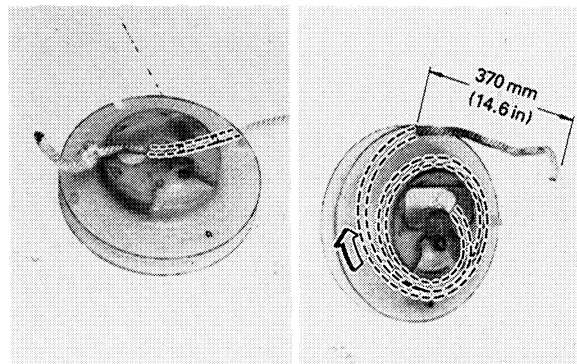

3. Install the shave drum in the starter case and turn the shave drum 4 turns clockwise to give spring a preload. Then insert the free rope end through the hole respectively in the case and make a knot of the rope end.

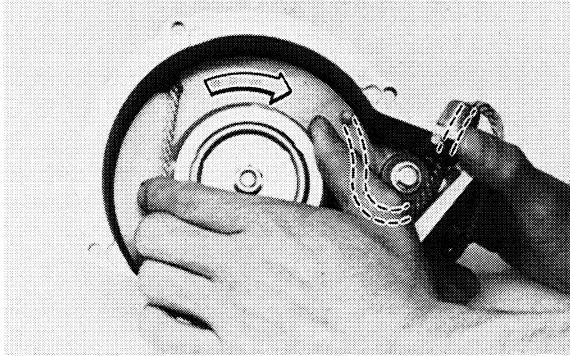

NOTE:

When installing the shave drum in the case, make sure the inner end of the spring and the split guide on the shave drum should be hooked each other.

4. Install the drive pawl, drive plate spring, and drive plate; then, tighten the spring washer and nut.

Tightening torque:
10 Nm (1.0 m · kg, 7.2 ft · lb)

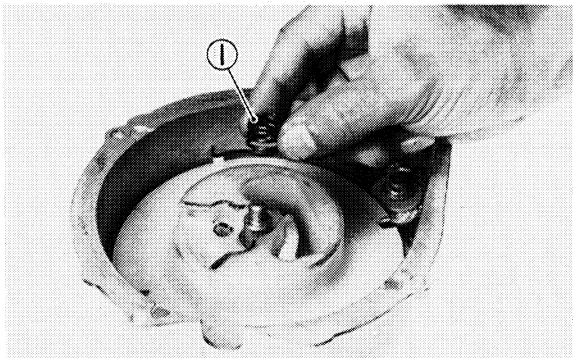

1. Drive plate spring

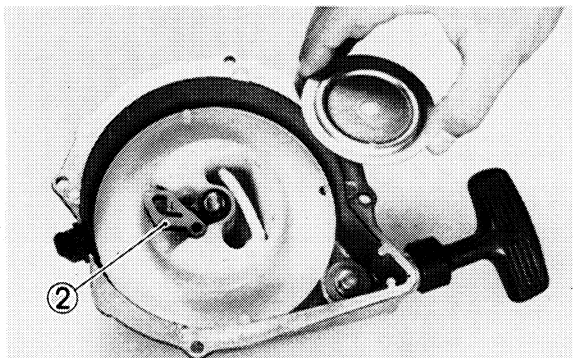

2. Drive pawl

NOTE:

Make sure the drive pawl, drive plate spring, and drive plate are installed in the correct way.

5. After the completion of assembly, check the starter for smooth operation. Pull out the starter rope about 80 ~ 130 mm (3 ~ 5 in), and make sure that the starter pawl moves out of the drive plate.

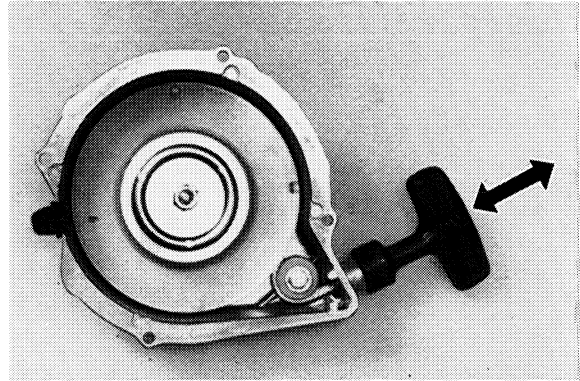

6. Install the starter assembly on the crank case.

Tightening torque:
7 Nm (0.7 m · kg, 5.1 ft · lb)

Clutch

1. Measure the friction plates at three or four points. If their minimum thickness exceeds tolerance, replace.

	New	Wear limit
Friction plate thickness	2.4 mm (0.09 in)	2.1 mm (0.08 in)

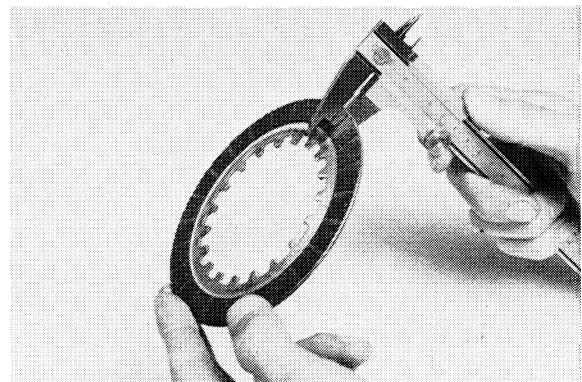

2. The steel clutch plates should be inspected for wear, heat damage and/or warpage. Check for warpage on a surface plate. If warpage exceeds 0.06 mm (0.002 in) and is accompanied by erratic clutch operation, replace. Heat discoloration indicates a malformation. Replace any heat-damaged plates and check friction plates, clutch hub and collar.

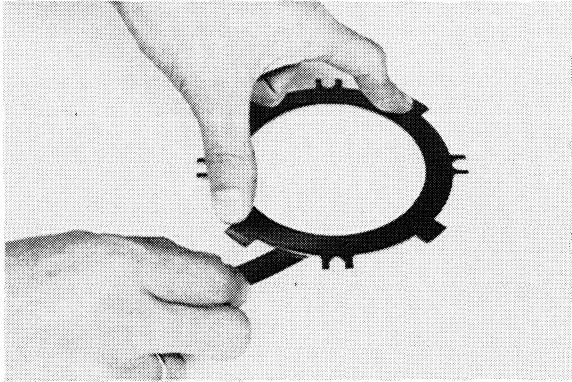

3. Clutch adjustment
 Measure the gap between the friction plate and pressure plate with a thickness gauge.
 If the gap is found incorrect, it should be properly adjusted by changing the thickness of the clutch plate.

Thickness
1.2 mm (0.047 in), 1.4 mm (0.055 in), or 1.6 mm (0.063 in)

Clutch adjustment gap
$1.6^{+0.15}_{-0.20}$ mm ($0.063^{+0.006}_{-0.008}$ in)

CAUTION
 Place the 1.6 mm (0.063 in) thick clutch plate on the outer side, with the machined surface facing inward.

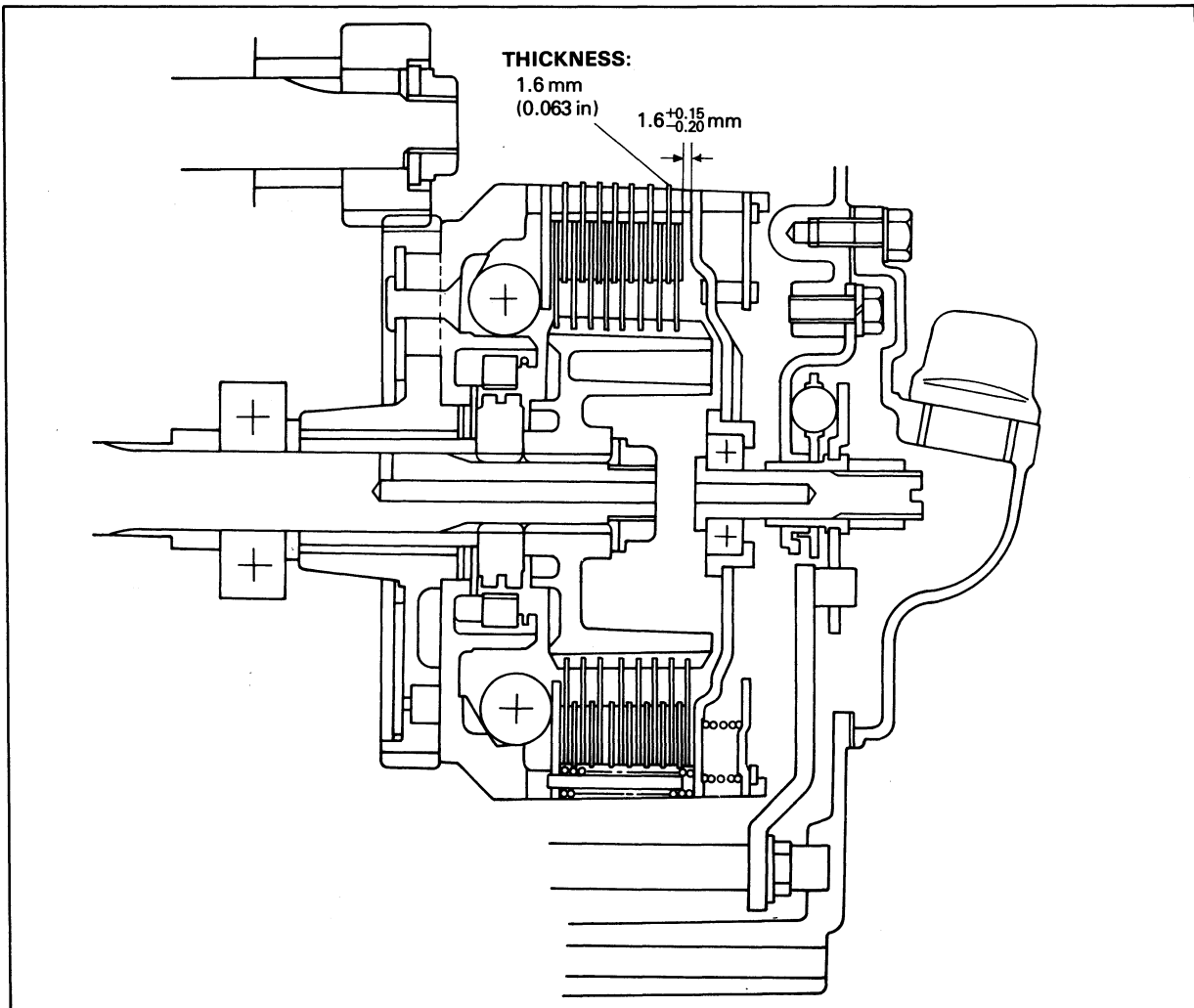

4. Measure each clutch spring and OFF spring. If beyond tolerance, replace.

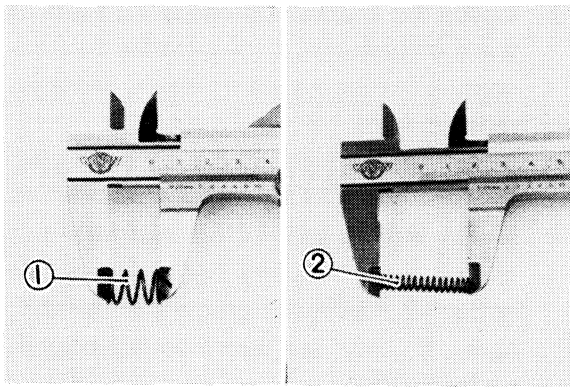

1. Clutch spring

2. OFF spring

	Color code	Q'ty	Free length
Clutch spring	Brown	8	15.2 mm (0.60 in)
OFF spring	Green	4	34.6 mm (1.36 in)

5. Clutch release mechanism adjustment

- 1) While holding nut 1, tighten the bolt until tight, and lock it with nut 2.
- 2) If the bolt can be turned lightly with your fingers and has no thrust play, the adjustment is correct.

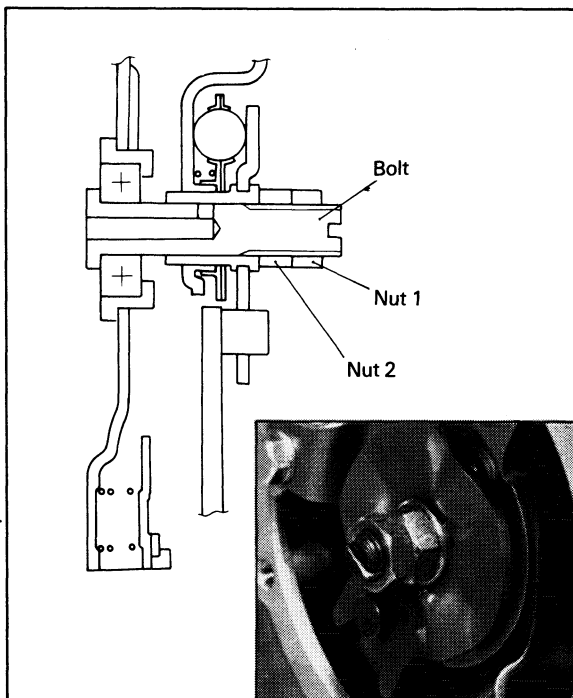

6. Trouble resulting from incorrect adjustment

- 1) If the bolt is insufficiently tightened:
The clutch will drag due to play of the bolt.

- 2) If the bolt is excessively tightened:

The clutch will slip even at high speeds and clutch plates may burn.

7. Thoroughly clean the primary driven gear assembly and spacer. Apply a light film of oil on the bushing surface and spacer. Fit the spacer into the bushing. It should be a smooth, thumb-press fit. The spacer should rotate smoothly within the bushing.
8. Check splines on clutch boss for signs of galling. If moderate, deburr. If severe, replace.

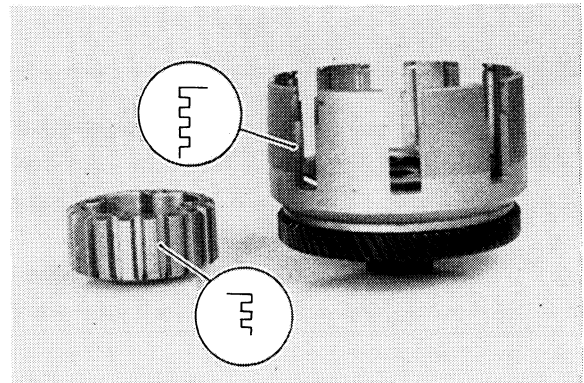

NOTE:

Galling on either the friction plate dogs of the clutch housing or clutch plate splines of the clutch boss will cause erratic clutch operation.

9. Checking the ball

Check balls for excessive wear or damage. If such wear is found, replace balls.

10. Checking the ratchet mechanism

Check for damage or wear on each pawl and dog. If damaged or worn to excess, replace it. Check the pawl-spring for damage and tension. If damaged or fatigued to excess, replace it.

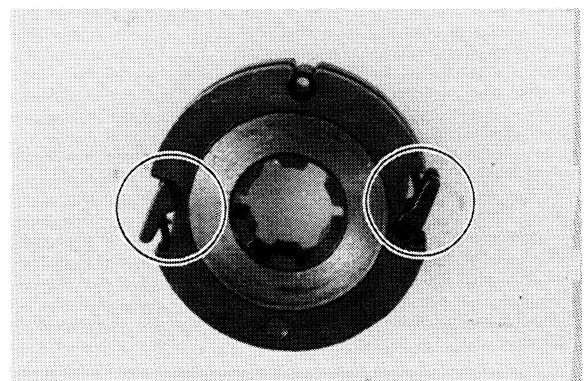

11. Checking the clutch release mechanism
Check the ball bearing fitted in the pressure plate (1) for wear or cratches.

Primary drive

The drive gear is mounted on the crankshaft; the driven gear is mounted on the transmission and is integrated with the clutch assembly.

Primary reduction ratio		
No. of teeth		Ratio
Drive	Driven	
25	68	2.72

1. Check the drive gear and the driven gear for obvious signs of wear or damage from foreign material within the primary case.
2. If the primary drive is excessively noisy during operation, replace both the drive and the driven gears.

Change shaft and change levers

1. Inspect shift return spring. A broken or worn spring will impair the return action of the shifting mechanism.
2. Inspect change shaft assembly for bending of shaft, worn or bent splines, and broken or worn shift arm spring. A bent shaft will cause hard shifting.

Transmission

1. Inspect each shift fork for signs of galling on gear contact surfaces. Check for bending. Make sure each fork slides freely on its guide bar.

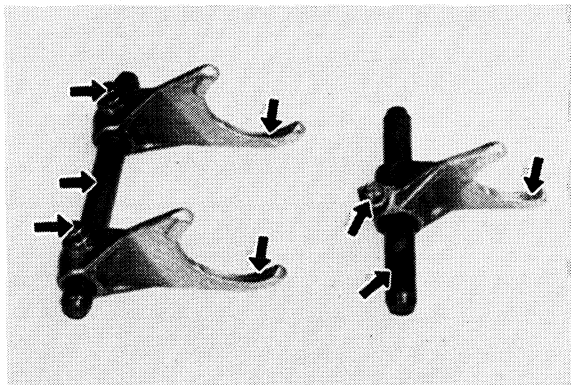

2. Roll the guide bars across a surface plate. If any bar is bent, replace.
3. Check the shift cam grooves for signs of wear or damage. If any profile has excessive wear and/or any damage, replace cam.
4. Check the cam followers on each shift fork for wear. The follower should fit snugly into its seat in the shift fork, but should not be overly tight. Check the ends that ride in the grooves in the shift cam. If they are worn or damaged, replace.

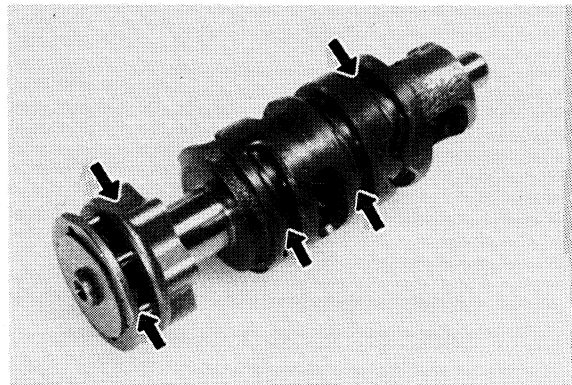

5. Check shift cam dowel pins and side plate for looseness, damage, or wear. Repair as required, or replace.
6. Check the shift cam stopper plate, circlip, stopper for wear.
7. Check the transmission shafts using a centering device and dial gauge. If any shaft is bent, replace.
8. Carefully inspect each gear. Look for signs of obvious heat damage (blue discoloration). Check the gear teeth for signs of pitting, galling, or other extreme wear. Replace as required.
9. Check to see that each gear moves freely on its shaft.
10. Check to see that all washers and clips are properly installed and undamaged. Replace bent or loose clips and bent washers.
11. Check to see that each gear properly engages its counterpart on the shaft. Check the mating dogs for rounded edges, cracks, or missing portions. Replace as required.

Crankshaft

1. The crankshaft requires the highest degree of accuracy in engineering and servicing of all the engine parts.
2. The crankshaft is susceptible to wear and therefore the crank bearings must be inspected with special care.
3. Check crankshaft components by the charts.
Check connecting rod axial play at small end (to determine the amount of wear of crank pin and bearing at large end).

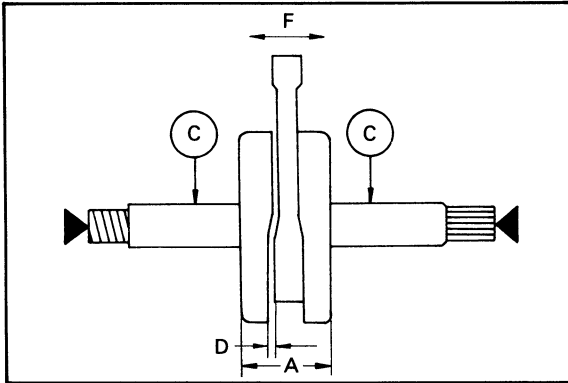

Crankshaft specifications

Crank width (A)	56 ^{-0.05} _{-0.10} mm (2.2 ^{-0.002} _{-0.004} in)
Runout limit (C)	0.03 mm (0.012 in)
Connecting rod big end side clearance (D)	0.2 ~ 0.7 mm (0.008 ~ 0.03 in)
Small end free play limit (F)	0.4 ~ 2.0 mm (0.016 ~ 0.08 in)

Bearings and oil seals

1. After cleaning and lubricating bearings, rotate inner race with a finger. If rough spots are noticed, replace the bearing.

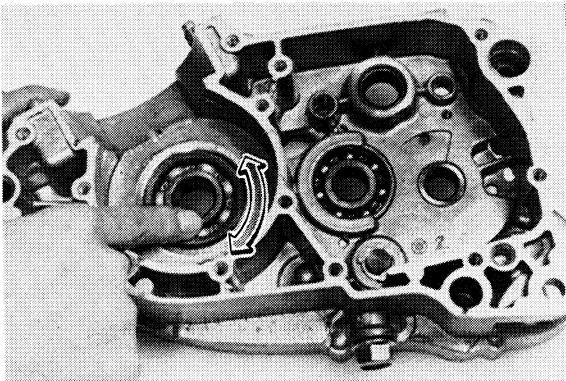

NOTE: _____

Bearing(s) are most easily removed or installed if the cases are first heated to approximately 90° ~ 120°C (194° ~ 248°F). Bring the case up to proper temperature slowly. Use an oven.

2. Check oil seal lips for damage wear. Replace as required.

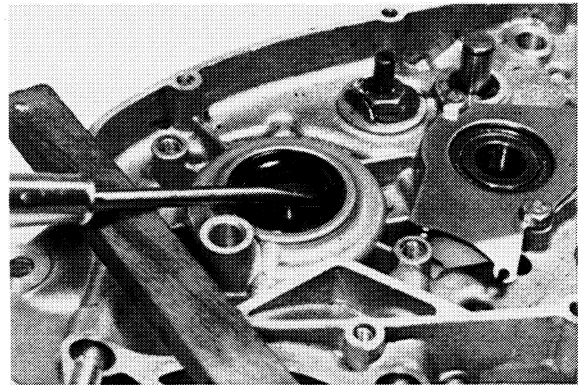

3. Always replace crankshaft oil seals whenever the crankshaft is removed.
4. Installation
Install bearing(s) and oil seal(s) with their manufacture marks or numbers facing outward (That is, you can see its marks or numbers easily.).

Crankcase

1. Visually inspect case halves for any cracks, damage etc.
2. If bearing(s) have been removed, check their seats for signs of damage (such as the bearing spinning in the seat, etc.).
3. Check oil delivery passages in transfer ports for signs of blockage.
4. If bearings have not been removed, oil them thoroughly immediately after washing and drying. Rotate the bearings, checking for roughness indicating damaged races or balls.
5. Check needle bearing(s) in transmission section for damage. Replace as required.

ENGINE ASSEMBLY AND ADJUSTMENT

Important information

Gaskets and seals

1. All gaskets and seals should be replaced when an engine is overhauled. All gasket surfaces and oil seal lips must be cleaned.
2. Properly oil all mating parts and bearings during reassembly.

Circlips

1. All circlips should be inspected carefully before reassembly. Always replace piston pin clips after one use. Replace distorted circlips.

When installing a circlip, make sure that the sharp edged corner is positioned opposite to the thrust it receives. See the sectional view below.

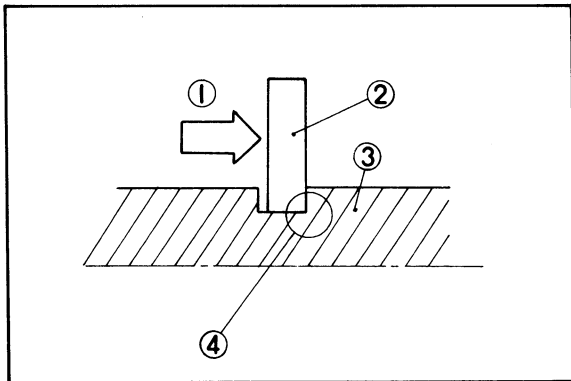

1. Thrust 2. Circlip 3. Shaft 4. Sharp edged corner

Lock washers/plates and cotter pins

1. All lock washers/plates and cotter pins must be replaced when they are removed. Lock tab(s) should be bent along the bolt or nut flat(s) after the bolt or nut has been properly tightened.

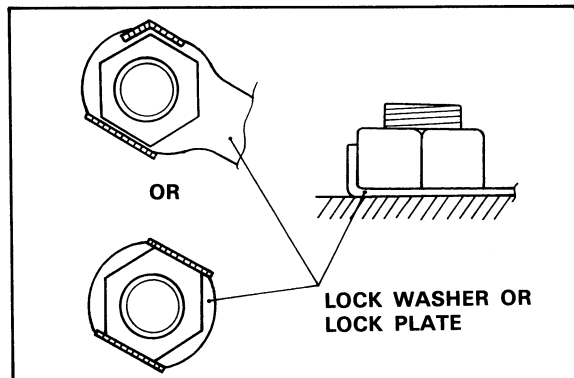

Bearings and oil seals

1. Install the bearing(s) and oil seal(s) with their manufacturer's marks or numbers facing outward. (In other words, the stamped letters must be on the side exposed to view.) When installing oil seal(s), apply a light coating of light-weight lithium base grease to the seal lip(s). When installing bearings liberally oil the bearings.

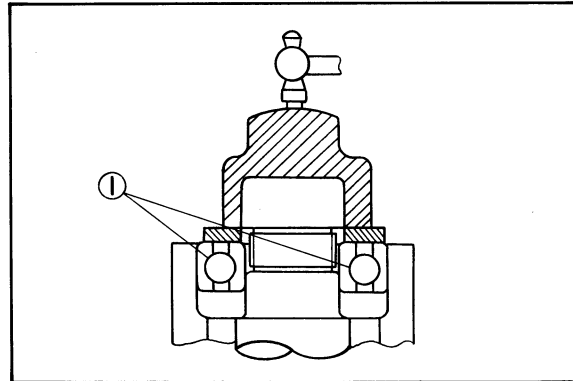

1. Bearing

Crankshaft installation

After all bearings and seals have been installed in both crankcase halves, install crankshaft as follows:

1. Set the crankshaft into left case half and install crankshaft installing tool.
2. Hold the connecting rod at top dead center with one hand while turning the handle of the installing tool with the other. Operate tool until crankshaft bottoms against bearing.

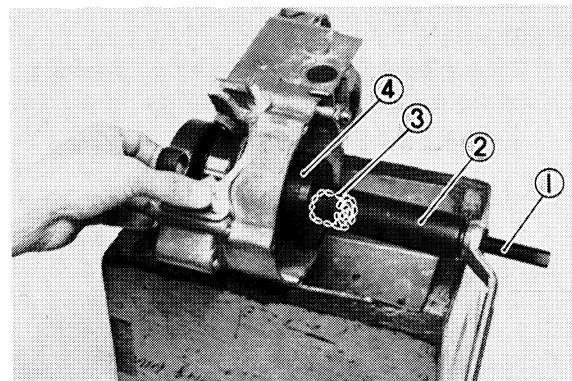

1. Crankshaft installer bolt 3. Crank installer bolt adapter
2. Crankshaft installer pot 4. Spacer

Transmission and shifter installation

1. Check to see that all parts move freely and that all loose shims are in place. Make sure all shafts are fully seated.

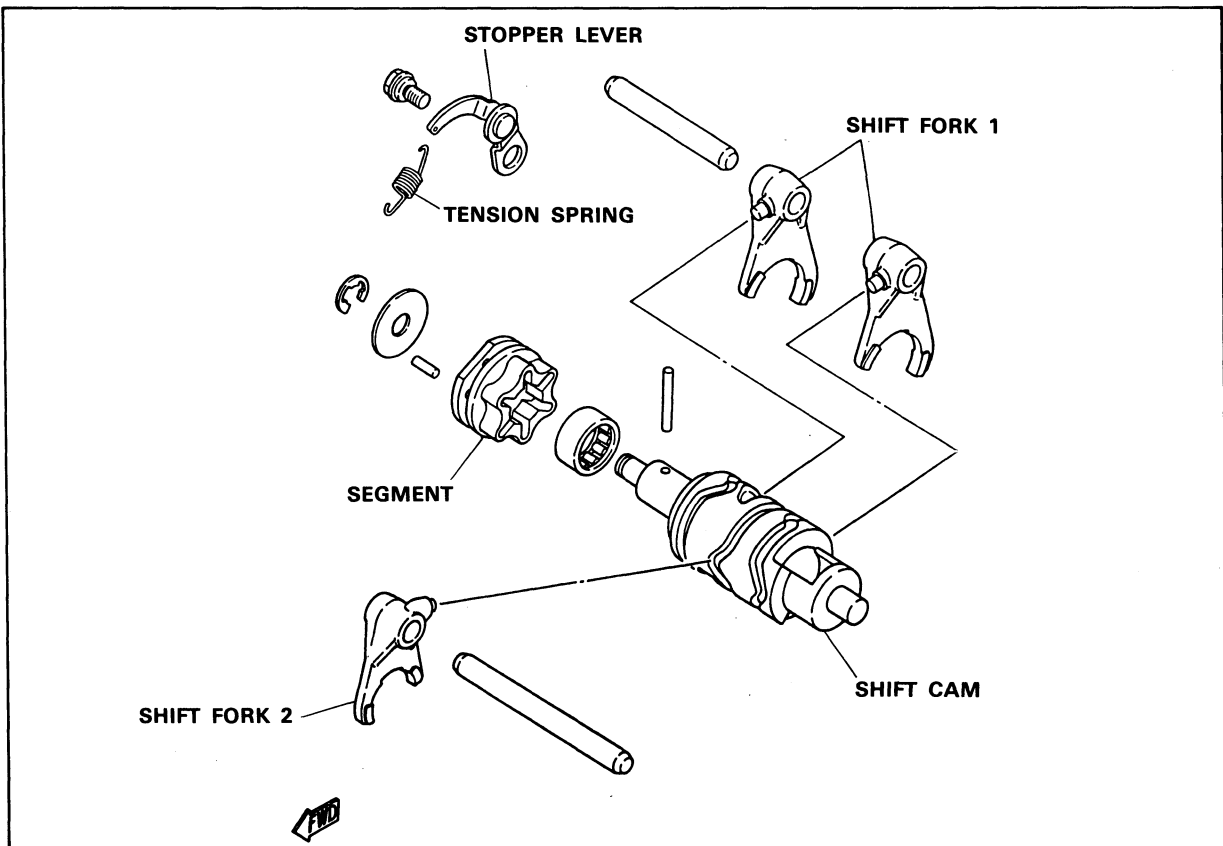
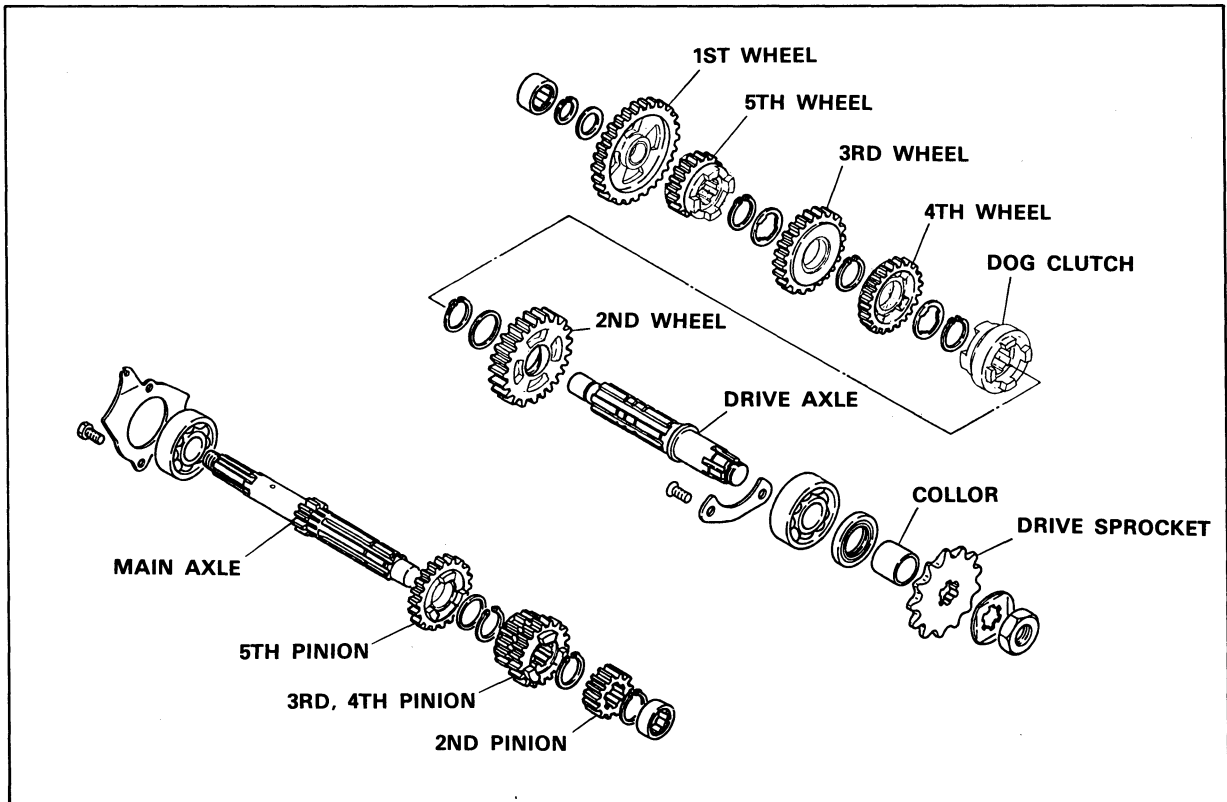

TRANSMISSION ASSEMBLY

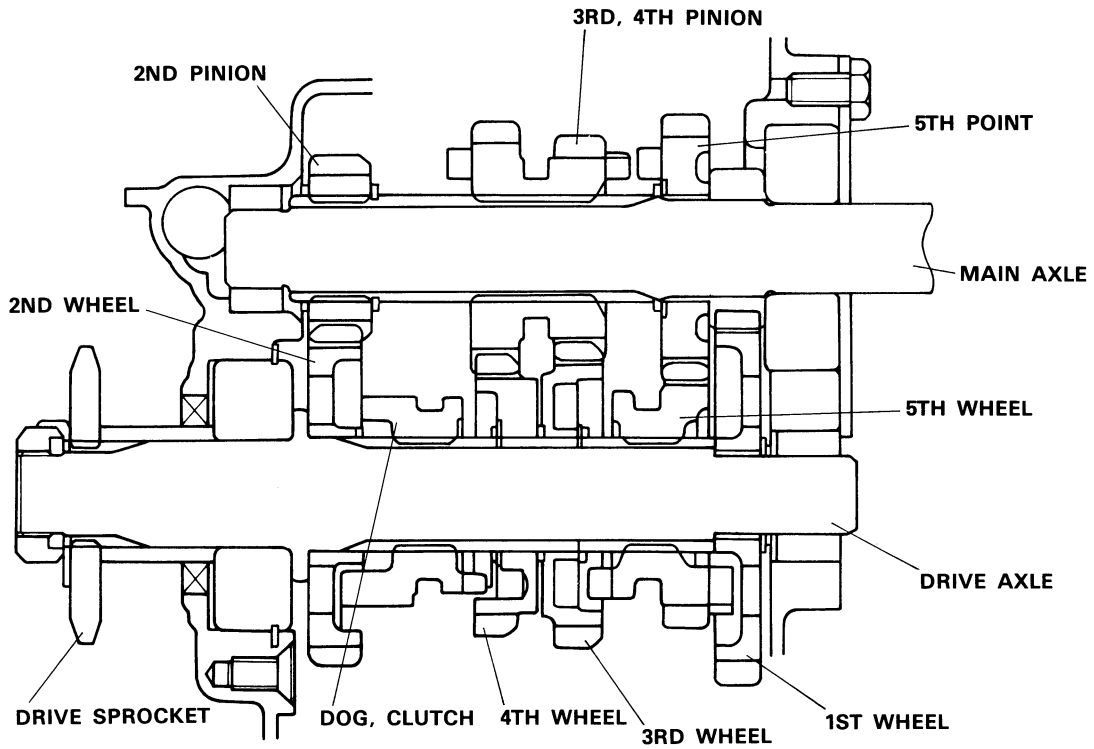

GEAR RATIO

1st	35/10 (3.500)
2nd	31/14 (2.214)
3rd	28/18 (1.555)
4th	25/21 (1.190)
5th	23/23 (1.000)

Crankcase

1. Apply YAMAHA BOND #4 to the mating surfaces of both case halves.

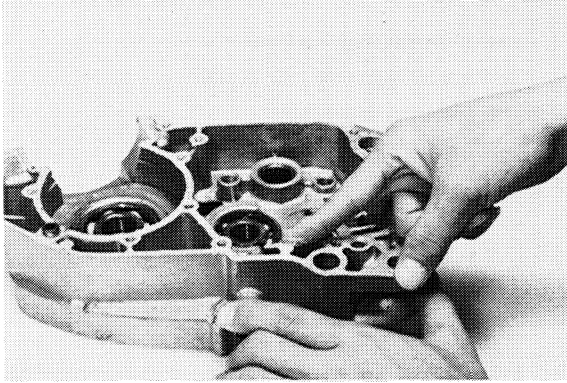

NOTE:

- a. Do not tap on machined surface or end of crankshaft.
 - b. Before installing the crankshaft, check the crankshaft O-ring for damage.
-
2. After reassembly, apply a liberal coating of two-stroke oil to the crank pin and bearing and into each crankshaft bearing oil delivery hole.
 3. Check crankshaft and transmission shafts for proper operation and freedom of movement.

Change shaft assembly

1. Take special care so that all parts are installed correctly. Refer to the illustration.
2. Engage the gear in first and adjust with adjusting screw so that the mating marks meet on segment and shift lever.

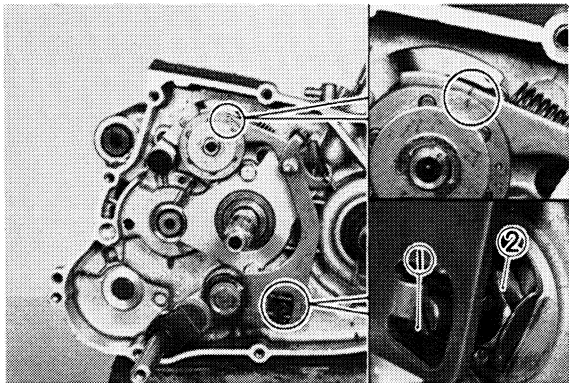

1. Adjusting screw
2. Lock nut

Primary drive gear and clutch assembly

1. Install the primary drive gear onto the crankshaft.

Primary drive gear nut torque:
55 Nm (5.5 m · kg, 40 ft · lb)

2. Install the clutch assembly onto the main axle.

Clutch boss tightening torque:
40 Nm (4.0 m · kg, 29 ft · lb)

CAUTION:

When install the circlip be sure to locate it as illustration below.

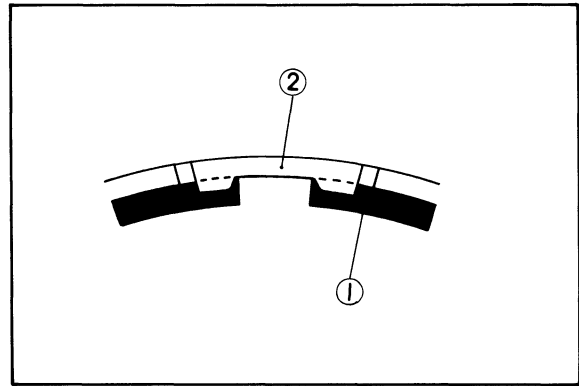

1. Circlip
2. Clutch housing

Crankcase cover (right)

Install crankcase cover.

Piston

1. During reassembly, coat the piston ring grooves, piston skirt areas, piston pin and bearing with two-stroke oil.
2. Install new piston pin clips and make sure they are fully seated in their grooves.

NOTE:

Take care during installation to avoid damaging the piston skirts against the crankcase as the cylinder is installed. Note the two induction holes in the piston skirt. These must be to the rear during installation.

Cylinder

1. Install a new cylinder base gasket.
2. Install cylinder with one hand while compressing piston rings with other hand.

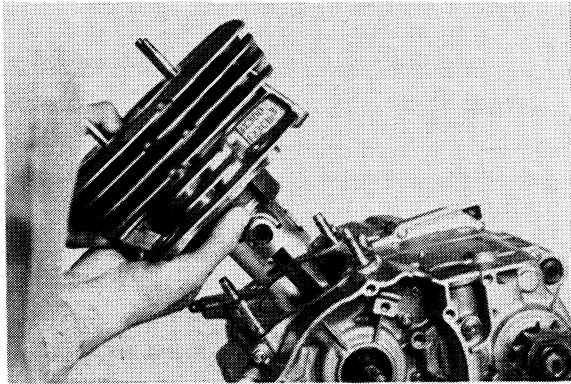

NOTE: _____
Make sure the rings are properly positioned.

Cylinder nut torque:
35 Nm (3.5 m · kg, 25 ft · lb)
Cylinder stud bolt:
45 Nm (4.5 m · kg, 33 ft · lb)

Cylinder head

Install cylinder head gasket and cylinder head.

Cylinder head nut torque:
30 Nm (3.0 m · kg, 22 ft · lb)
Cylinder head stud bolt:
25 Nm (2.5 m · kg, 18 ft · lb)

Reed valve

Install the reed valve assembly and carburetor.

NOTE: _____

Bring the chamber in the cylinder reed valve housing to align with the 5-mm-diameter hole in the reed valve body and the pipe joint attached to the carburetor joint, and tighten the reed valve assembly.

If these are out of alignment, the fuel pump will malfunction and no fuel will reach the carburetor, thus making it impossible to start the engine.

Tightening torque:
8 Nm (0.8 m · kg, 5.8 ft · lb)

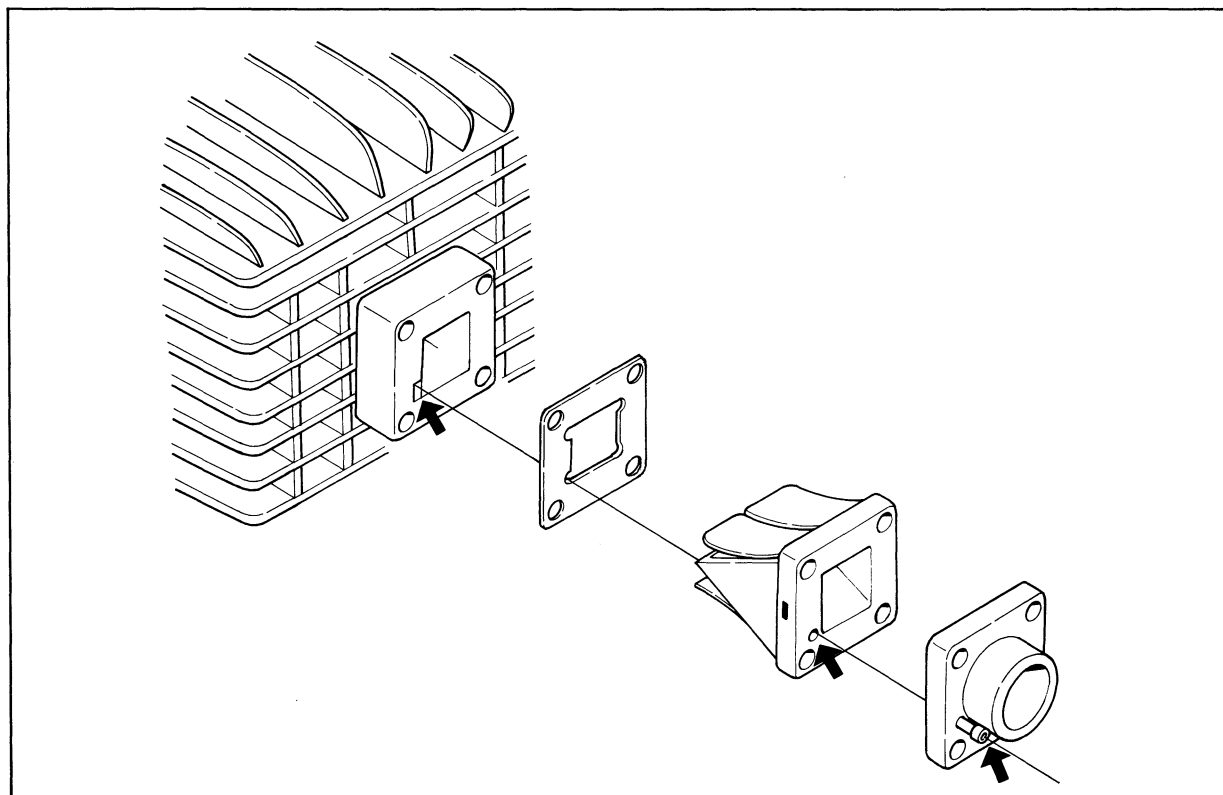

MOUNTING

1. Install the engine by reversing the removal procedures.
2. Torque the all bolts and nuts to specification.

TIGHTENING TORQUE:

Engine mount

- Front upper:
31 Nm (3.1 m · kg, 22.5 ft · lb)
- Rear upper:
31 Nm (3.1 m · kg, 22.5 ft · lb)
- Rear under:
42 Nm (4.2 m · kg, 30.5 ft · lb)

Drive sprocket nut;

55 Nm (5.5 m · kg, 40 ft · lb)

Flywheel magnet;

70 Nm (7.0 m · kg, 50 ft · lb)

4. Install the side cover, seat assembly.
5. Add transmission oil.

Transmission oil capacity:

0.8 ~ 0.9 L

(0.7 ~ 0.8 Imp qt, 0.8 ~ 1.0 US qt)

3. Install the exhaust pipe assembly.
Use a new gasket.

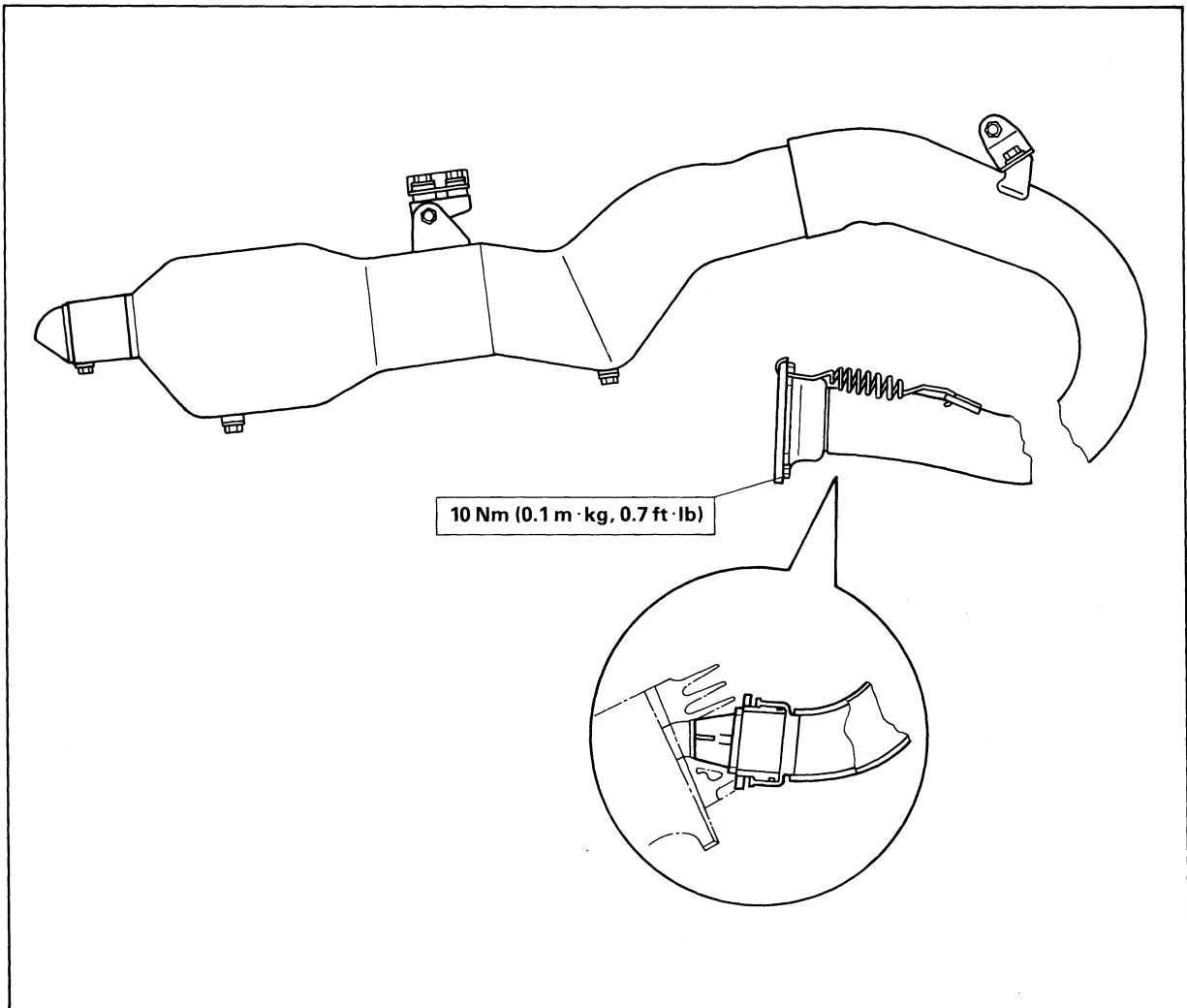

CHAPTER 4. CARBURETION

CARBURETOR	4-1
Specifications	4-2
Inspection	4-2
Adjustment	4-2
REED VALVE	4-4
Inspection	4-4
Water release valve	4-4
FUEL PUMP	4-5
Fuel pump inspection	4-5

CARBURETION

CARBURETOR

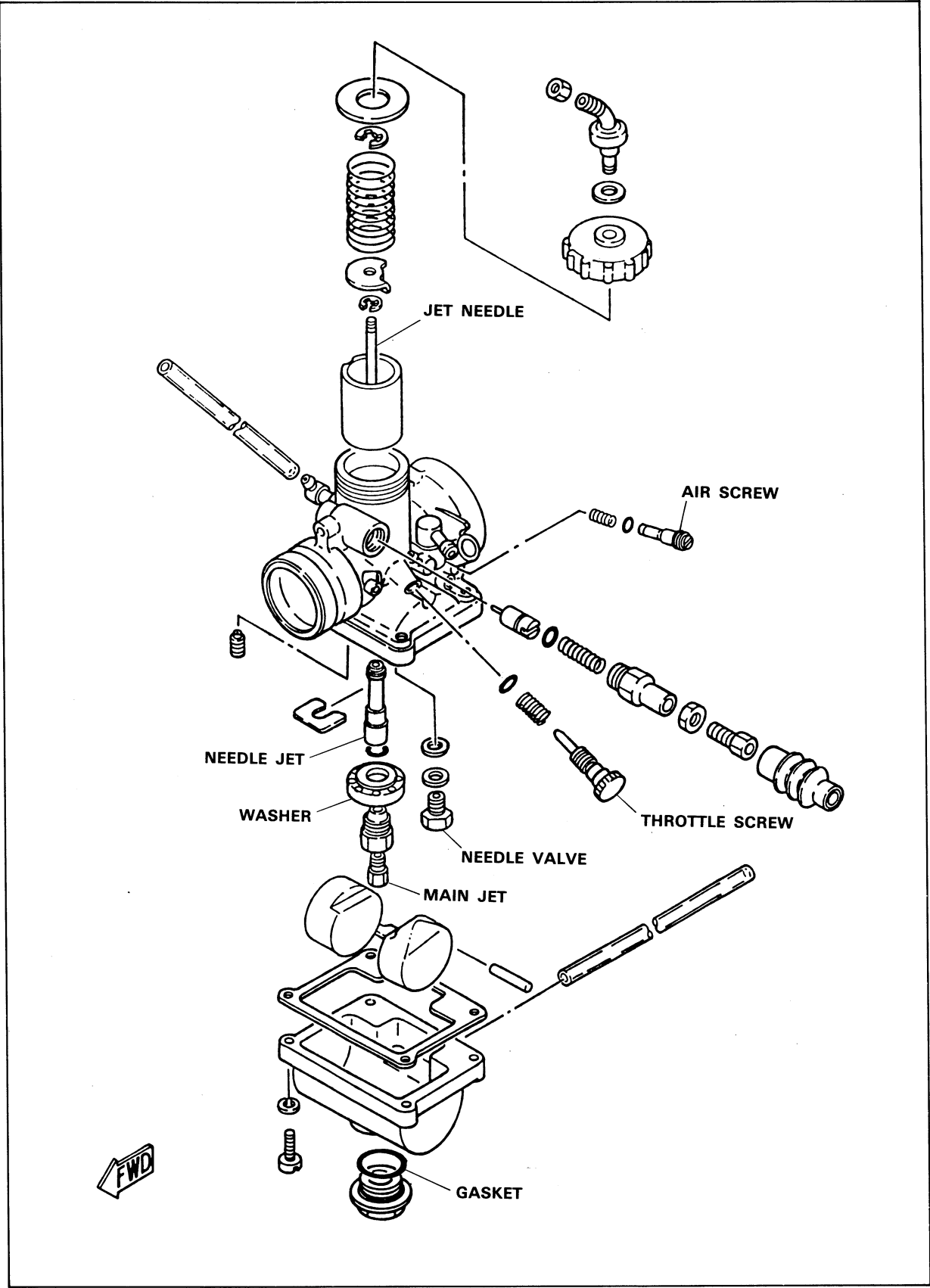

Specifications

Type:	VM24SS
Main Jet:	#165
Jet Needle:	4K4-3
Air Screw:	1 and 1/4
Pilot Jet:	#40
Float Height:	25 ± 1 mm (0.98 ± 0.04 in)
Engine Idling Speed:	$1,600 \pm 50$ r/min

Inspection

1. Examine carburetor body and fuel passages. If contaminated, wash carburetor in petroleum based solvent. Do not use caustic carburetor cleaning solutions. Blow out all passages and jets with compressed air.
2. Examine condition of floats. If floats are damaged, they should be replaced.
3. Inspect inlet float valve and seat for wear or contamination. Replace these components as a set.

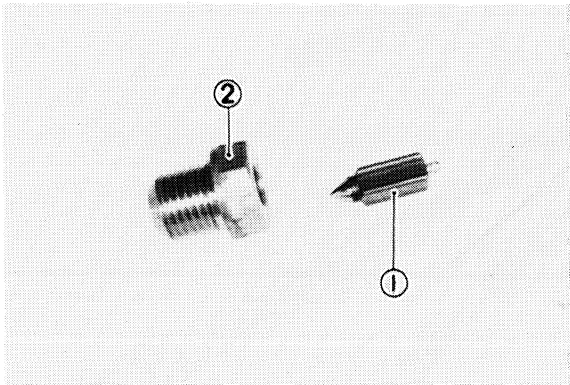

1. Float valve 2. Valve seat

4. Inspect the jet needle for bends or wear. If the needle is bent or severely worn, replace it.

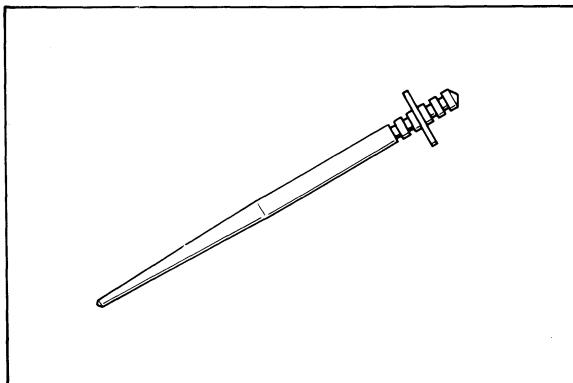

Adjustment

1. Float height
 - a. Reinstall components, except for the float chamber. Incline the carburetor until the float arm tang lightly contacts the float valve (so that the end of the float valve does not hang down of float weight), and measure the distance from the mating surface of the float chamber (gasket removed) and carburetor to the top of the float using a gauge.

Float height:
 25 ± 1 mm (0.98 ± 0.04 in)

NOTE:

The float should be just resting on, but not depressing the spring loaded inlet needle.

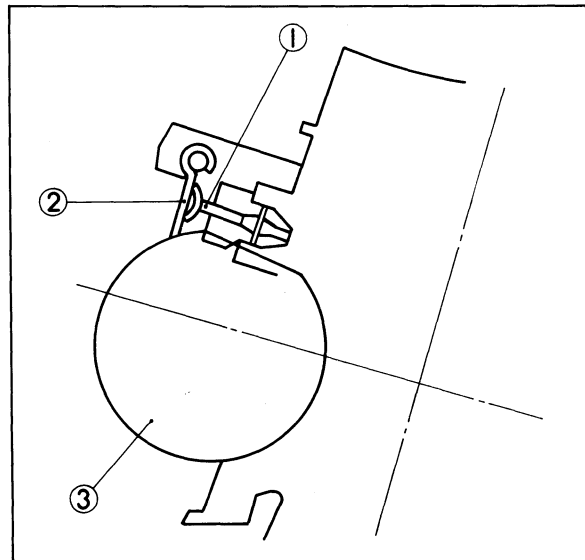

1. Float valve 2. Float arm 3. Float

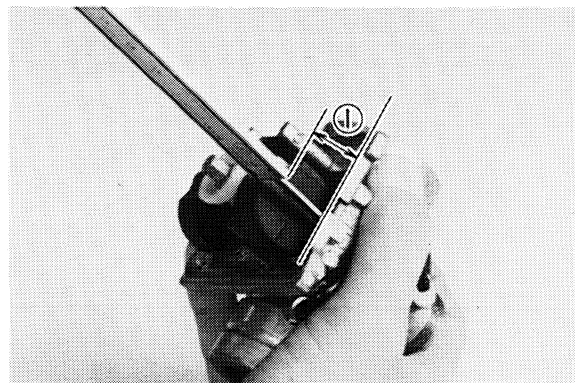

1. Float level

b. If the float level is not within the specified range, check the valve seat and needle valve. And replace any damaged part.

If any part is in good condition but float level is not within the specified range, correct float level by bending the float arm tang slightly.

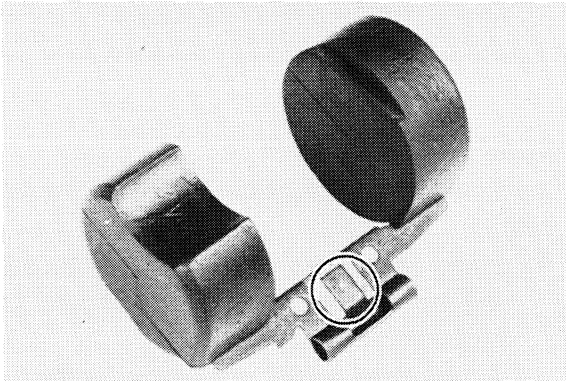

c. Adjustment

CAUTION:

Check the float valve and valve seat for wear before adjustment.

Make the adjustment by bending the tang on the float arm.

2. Jet needle

If it is necessary to alter the mid-range air/fuel mixture characteristics of the machine, the jet needle position may be changed. Move the jet needle up for a leaner condition or toward the bottom position for a richer condition.

Jet needle type: 4K4
Clip position: No. 3 Groove

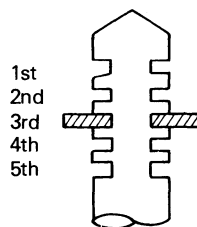

REED VALVE

Inspection

1. Inspect rubber intake manifold for signs of weathering, checking or other deterioration.
2. Inspect reed petals for signs of fatigue and cracks. Reed petals should fit flush or nearly flush against neoprene seats. If in doubt as to sealing ability, apply suction to carburetor side of assembly. Leakage should be slight to moderate.
3. The valve stopper controls the movement of the valve. Check clearance "a".

Standard value "a": 9 mm (0.35 in)

If it is 0.5 mm (0.020 in) more or less than specified, replace the valve stopper.

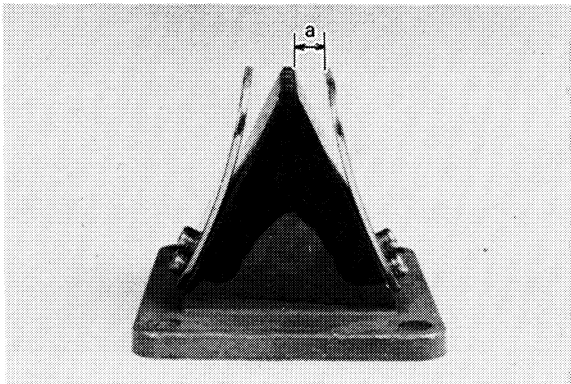

4. Check reed valve for bending. If beyond tolerance, replace reed valve.

Reed valve bending limit:
0.2 mm (0.008 in)

5. During reassembly, note the cut in the lower corner of the reed and stopper plate. Use as aid to direction of reed installation.

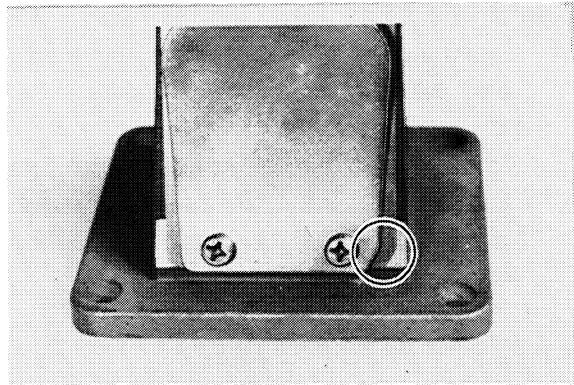

Water release valve

Check the valve for good sealing or movement.

1. If the valve does not provide good sealing nor move smoothly, it should be replaced with a new one. A defective valve may allow water to leak in while riding in the rain or crossing water paddles.

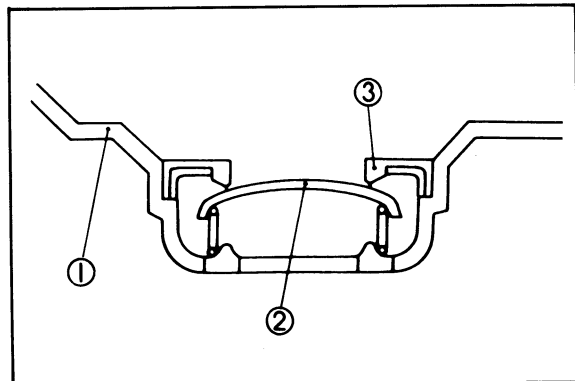

1. Air filter case 2. Float valve 3. Oil seal

FUEL PUMP

Fuel pump inspection

Check to see if fuel moves from tank to carburetor, and if any fuel leaks from pipe joints or fuel pump body.

Replace the fuel pump assembly as required.

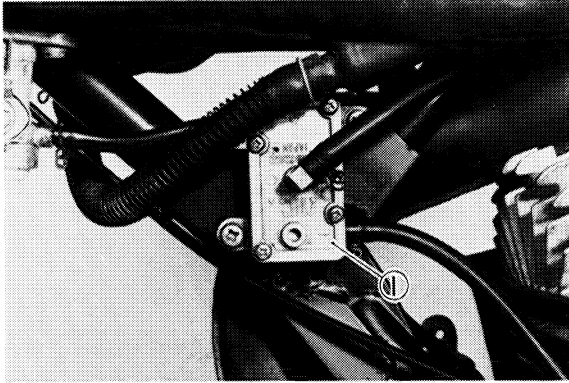

1. Fuel pump

NOTE: _____

The fuel pump should not be disassembled. If it malfunctions, replace it with a new one.

Piping

NOTE: _____

Fuel pump installation, as well as piping, should be carried out in the correct manner. For fuel pump installation and piping, refer to the diagram given below:

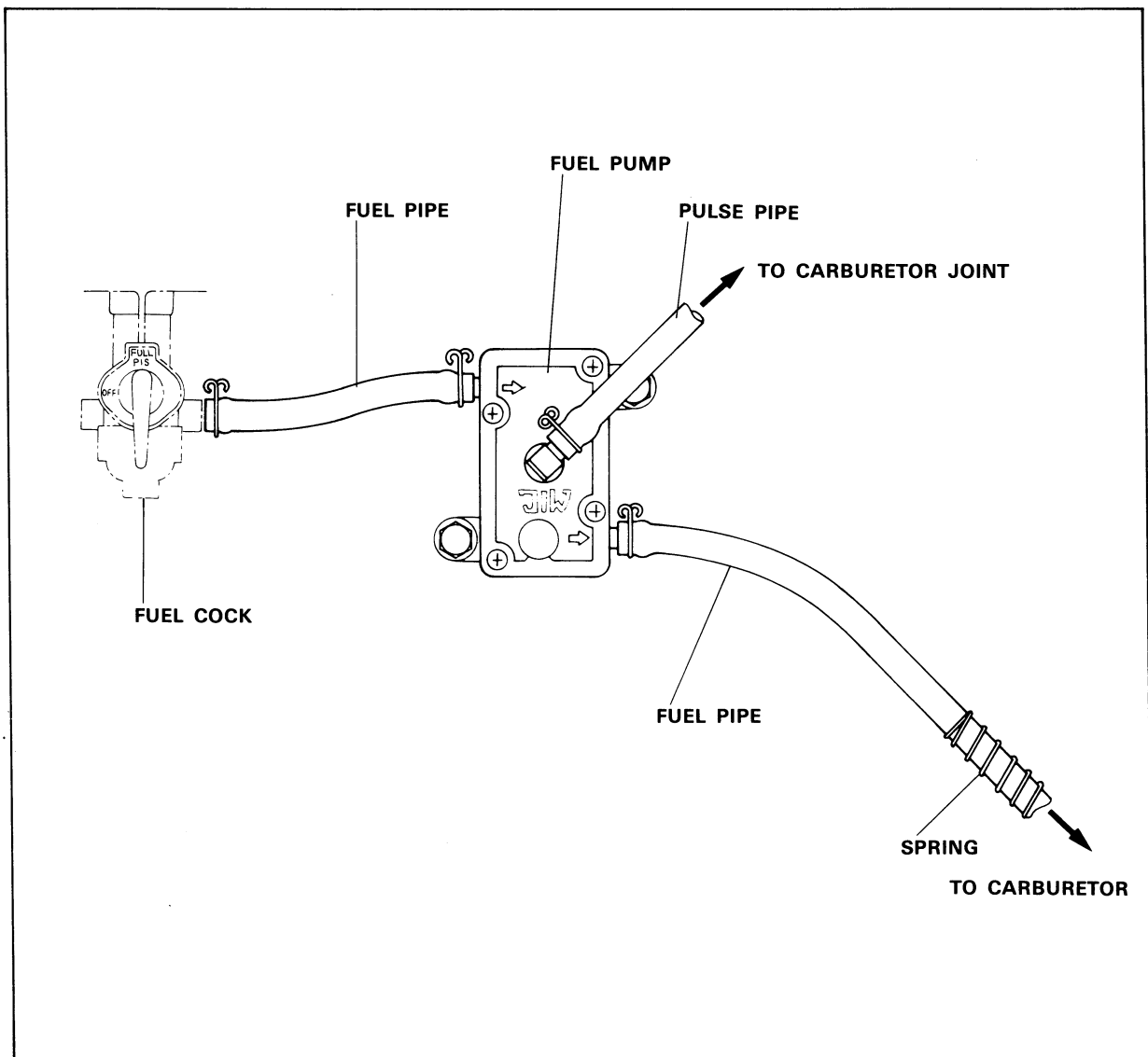

CHAPTER 5. CHASSIS

FRONT WHEEL	5-1
Removal.....	5-1
Front axle inspection	5-1
Front wheel inspection	5-1
Checking brake shoe wear	5-1
Brake drum	5-2
Brake shoe plate	5-2
Replacing the wheel bearings	5-2
Installing the front wheel.....	5-2
REAR WHEEL	5-3
Removal.....	5-3
Rear wheel inspection.....	5-3
Replacing the wheel bearings	5-3
Checking the rear axle	5-4
Installing the rear axle	5-4
Installing the rear wheel	5-5
REAR BRAKE	5-6
Brake pad replacement	5-6
Brake inspection and repair.....	5-6
Brake assembly.....	5-7
FRONT FORK	5-9
Removal and disassembly	5-10
Inspection	5-11
Assembly.....	5-11
Installing the front fork	5-12
STEERING HEAD	5-13
Adjustment	5-14
Removal.....	5-14
Inspection	5-14
Assembly.....	5-14

DRIVE CHAIN AND SPROCKETS 5-15
 Adjustment 5-15
 Sprocket inspection 5-15
 Removal 5-16
 Assembly 5-16
 Drive chain cleaning and lubrication 5-16

CABLE AND FITTINGS..... 5-17
 Cable maintenance..... 5-17

CHASSIS

FRONT WHEEL

Removal

1. Elevate the front wheel by placing a suitable stand under the footrest.



2. Remove brake cable. Loosen all cable adjusters and remove cable from handle lever holder. Then remove cable from cam lever at front brake shoe plate.
3. Remove cotter pin from front wheel axle and remove axle nut.

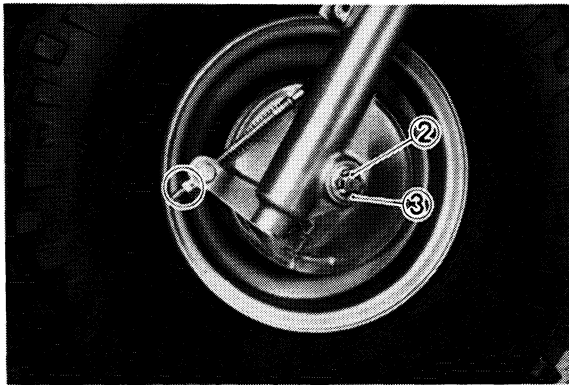

1. Adjuster 2. Axle nut 3. Cotter pin

4. Remove the front wheel axle, collar, and front wheel assembly from the front fork.

Front axle inspection

Remove any corrosion from the axle with emery cloth. Place the axle on a surface plate and check for bent. If bent, replace the axle. Do not attempt to straighten a bent.

Front wheel inspection

1. Check for cracks, bends or warpage of the wheels. If a wheel is deformed or cracked, it must be replaced.
2. Check wheel runout.
If deflection exceeds tolerance below, check the wheel bearing or replace wheel as required.

Rim runout limits:

Vertical — 1.0 mm (0.039 in)

Lateral — 1.0 mm (0.039 in)

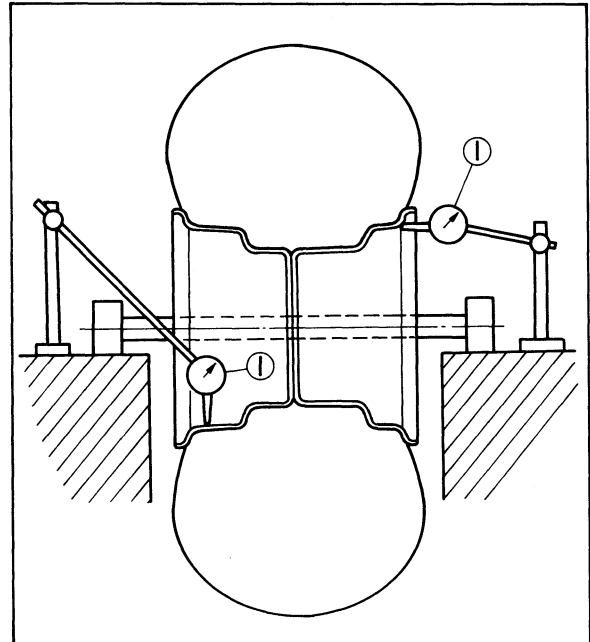

1. Dial gauge

Checking brake shoe wear

1. Check the brake linings for damage and wear. If the thickness is less than the specified value, replace the brake shoe as a set.

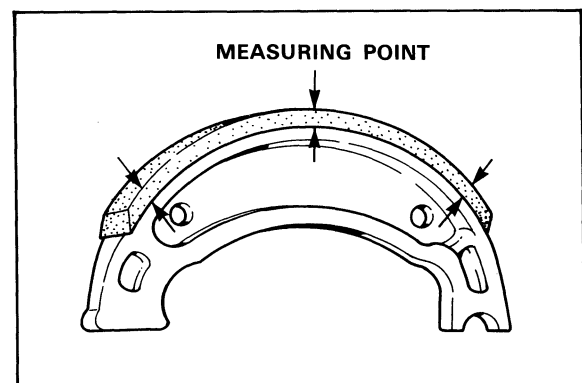

Wear limit: 2 mm (0.08 in)

Brake drum

Oil or scratches on the inner surface of the brake drum will impair braking performance or result in abnormal noises. Remove oil by wiping the brake drum with a rag soaked in lacquer thinner or solvent. Remove scratches by lightly and evenly polishing the brake drum with emery cloth.

Brake shoe plate

Remove the camshaft, and grease it. If the cam face is worn, replace the camshaft.

NOTE:

Before removing the cam lever, put alignment marks on the cam lever and camshaft to indicate their relative positions for easy assembly.

Replacing the wheel bearings

If the bearings allow play in the wheel hub or if the wheel does not turn smoothly, replace the bearings as follows:

1. Clean the outside of the wheel hub.
2. Drive the bearing out by pushing the spacer aside and tapping around the perimeter of the bearing inner race with a soft metal drift punch and hammer. The spacer "floats" between the bearings. Both bearings can be removed in this manner.

WARNING:

Eye protection is recommended when using striking tools.

3. To install the wheel bearing, reverse the above sequence. Use a socket that matches the outside diameter of the race of the bearing to drive in the bearing.

CAUTION:

Do not strike the center race or balls of the bearing. Contact should be made only with the outer race.

Installing the front wheel

When installing the front wheel, reverse the removal procedure. Note the following points.

1. Lightly grease the lips of the front wheel oil seals. Use lightweight lithium soap base grease.
2. Make sure the projecting portion (torque stopper) of the brake shoe plate is positioned correctly.

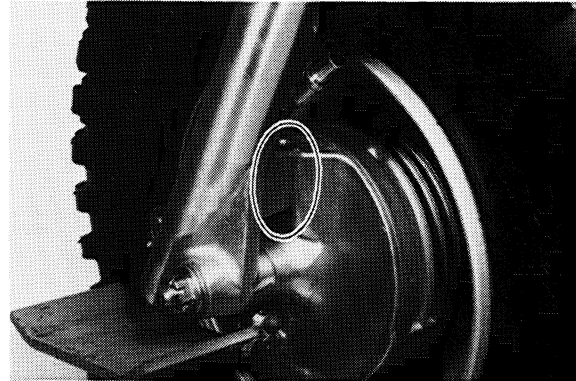

1. Torque stopper

3. Tighten the axle nut and install a new cotter pin.

Tightening torque:

50 Nm (5.0 m · kg, 36 ft · lb)

WARNING:

Always use a new cotter pin on the axle nut.

4. Install the brake cable.
5. Adjust the brake.
Refer to "Front brake adjustment" on page 2-9.

Front brake free play:

9 ~ 15 mm (0.35 ~ 0.59 in)

REAR WHEEL

Removal

1. Block the front tire and juck up the rear of the vehicle. Apply the parking brake.

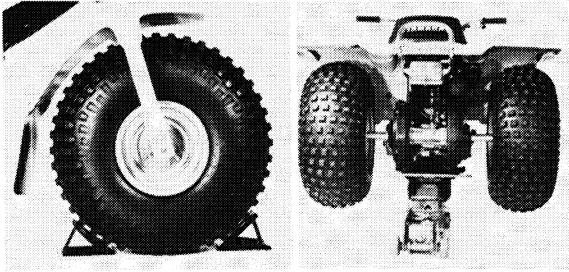

2. Remove the wheel nuts from rear wheel panel.

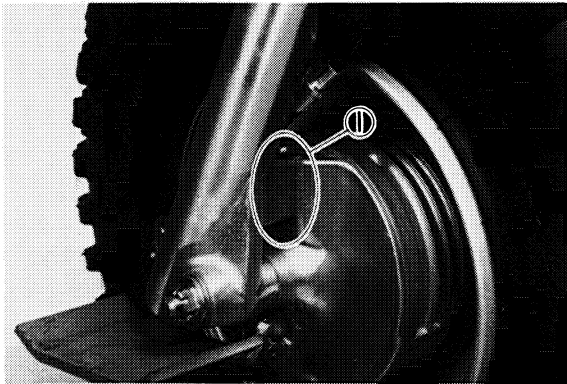

1. Wheel nut

3. Remove the rear wheel assembly.

Rear wheel inspection

See "Front wheel inspection" on page 5-1.

Replacing the wheel bearings

1. Block the front tire and juck up the rear of the vehicle. Apply the parking brake.

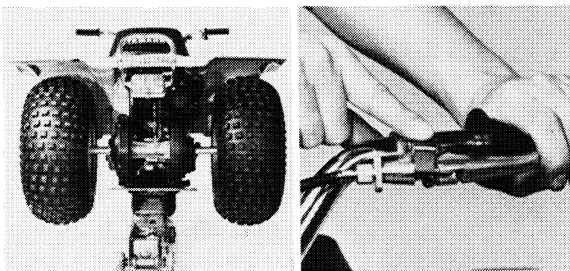

2. Remove the cotter pins from the right and left rear wheel, loosen the axle nuts and remove the tires.

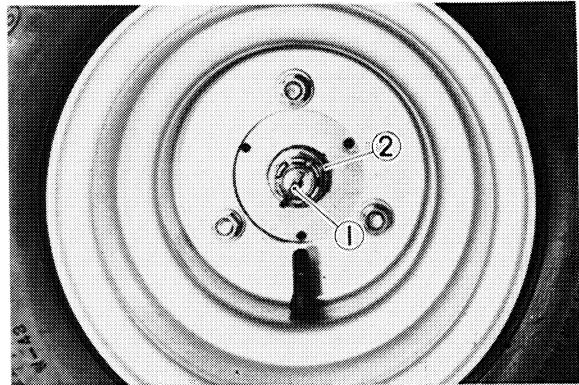

1. Cotter pin 2. Axle nut

3. Remove the pad case and chain case.
4. Straighten the lock washer on the right side and loosen the ring nut, and release the parking brake.

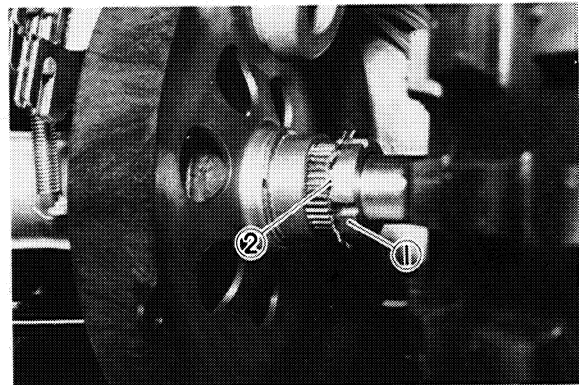

1. Ring nut 2. Lock washer

5. Loosen the caliper holding nuts and remove the outer caliper and disc plate.

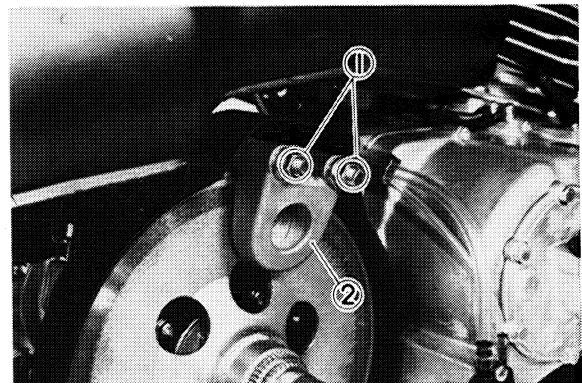

1. Caliper holding nut 2. Outer caliper

6. Loosen the drive chain.
7. Pull out the rear axle from the rear wheel by tapping it with a plastic hammer.

8. Remove the rear wheel sprocket and drive chain.
9. Replace the oil seals and bearings with new ones.

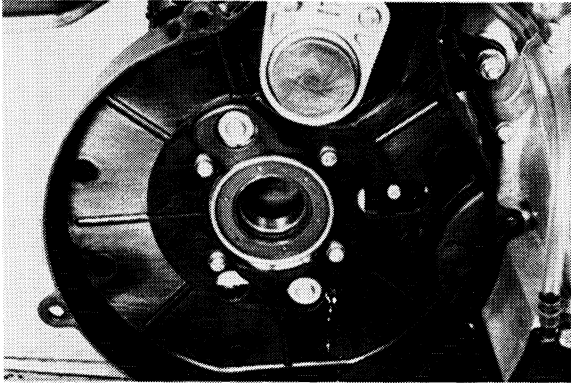

NOTE: _____
 Before installing the bearing(s) or oil seal(s), apply grease to them.

Recommended grease:
 Medium weight wheel bearing grease

Checking the rear axle

1. As shown below, support the rear axle by placing V-blocks under the bearing mounting positions and check for the rear axle at both ends.

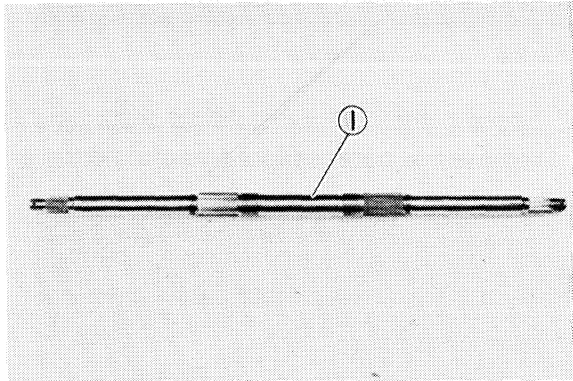

1. Rear axle

Rear axle runout limit:
 1.5 mm (0.06 in)

2. If the runout exceeds 1.5 mm (0.06 in), replace the rear axle with a new one.

**Installing the rear axle
 (Positioning the rear axle)**

1. Drive the rear axle into the rear hub.

NOTE: _____
 The rear shaft is shaped symmetrical so that it can be inserted from either end.

2. Install the drive chain.

Tightening torque:
 Drive sprocket:
 55 Nm (5.5 m · kg, 40 ft · lb)
 Wheel sprocket:
 45 Nm (4.5 m · kg, 32.5 ft · lb)

3. Install the disk plate boss and grease the splines.

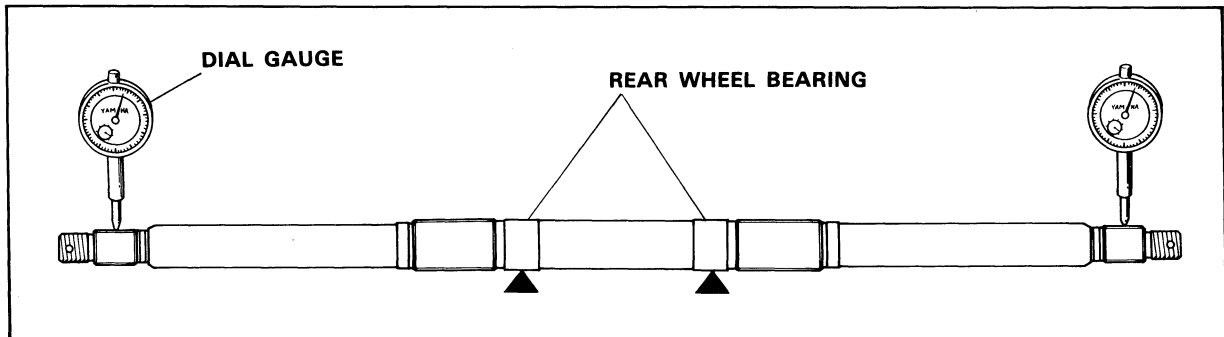
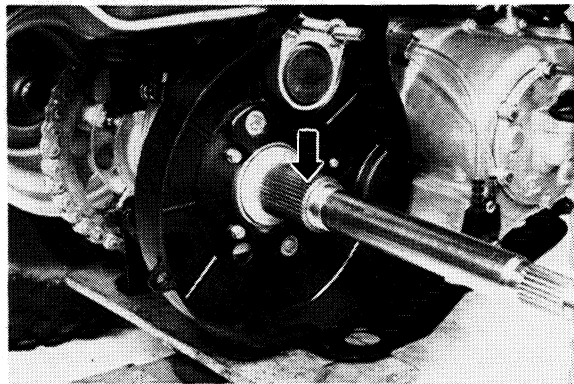

WARNING:

Avoid applying too much grease, or it overflows to the disc plate, thus causing brake slippage. Therefore, after greasing, install the disc plate, and slide it a few times, then wipe off the grease on the disc plate.

4. Install the ring nut and lock washer on one end of the rear axle and screw in the ring nut to the specified position.

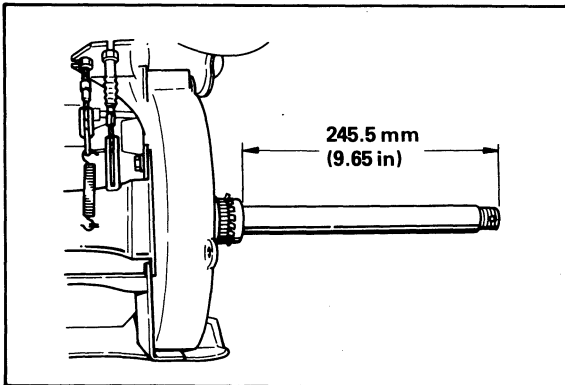

5. After screwing in the ring nut, install another ring nut and lock washer on the other end of the rear axle, and tighten the ring nut to specification.

Tightening torque:
135 Nm (13.5 m · kg, 98 ft · lb)

6. Tighten the ring nut, which is set in 4. above, to specification.

Tightening torque:
135 Nm (13.5 m · kg, 98 ft · lb)

7. Bending the lock washers over the ring nuts on both ends of the rear axle.

NOTE:

Always use new lock washers.

8. Tighten the caliper and install the pad case and chain case.

Tightening torque:
39 Nm (3.9 m · kg, 28 ft · lb)

9. Adjust the drive chain.
Refer to "Drive chain adjustment" on page 2-11.
10. Adjust the rear brake.
Refer to "Rear brake adjustment" on page 2-9.
11. Install the rear wheels.

Rear axle tightening torque:
110 Nm (11 m · kg, 80 ft · lb)

NOTE:

Always use new cotter pins.

Installing the rear wheel

1. To install the rear wheels, reverse the removal procedures.

Wheel nut tightening torque:
45 Nm (4.5 m · kg, 32.5 ft · lb)

REAR BRAKE

Brake pad replacement

1. Block the front tire and juck up the rear of the vehicle.

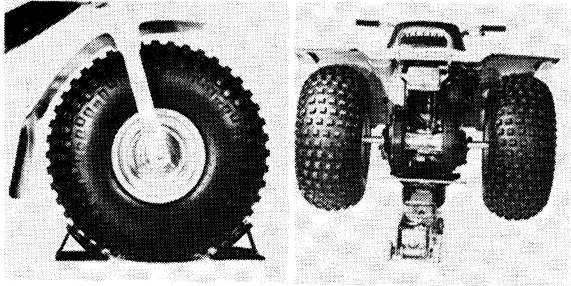

2. Apply the parking brake to lock the rear wheels. Remove the pad case.

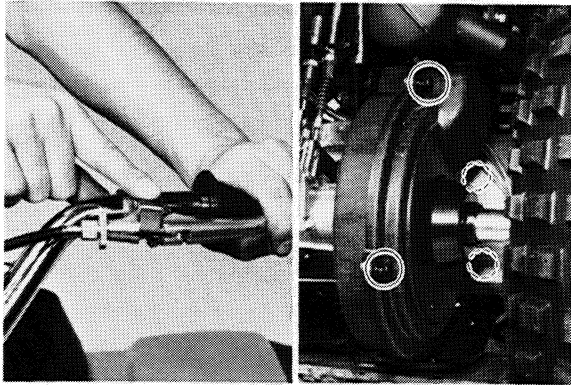

3. Straighten the lock washer and loosen the ring nut.

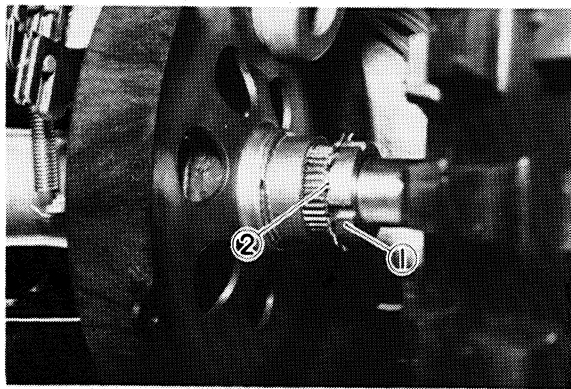

1. Ring nut 2. Lock washer

4. Release the parking brake to set the rear wheel free. Loosen the caliper holding nuts and remove the outer caliper.

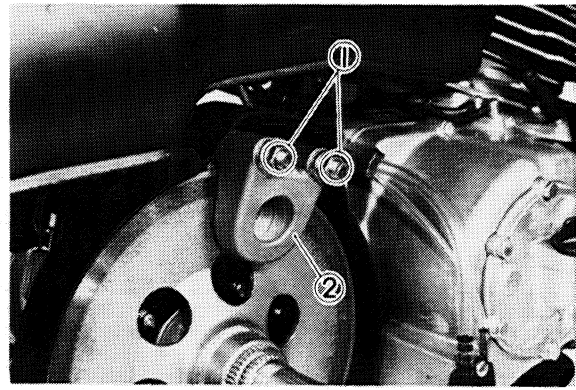

1. Caliper holding nut 2. Outer caliper

5. Pull out the disk plate.

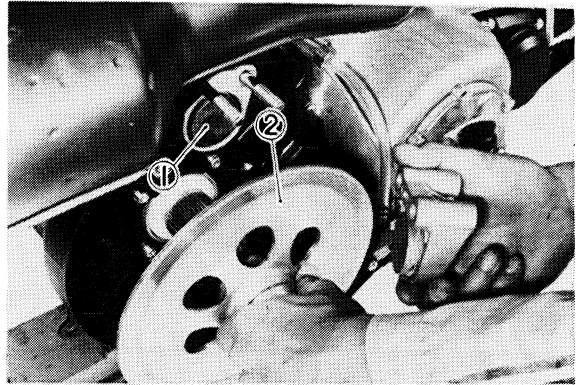

1. Inner caliper 2. Disc plate

6. Replace the inner and outer brake pads with new ones.

NOTE:

Replace the pads as a set if either one is worn to the specified limit.

Wear limit: 1.5 mm (0.06 in)

Brake inspection and repair

1. Replace the caliper piston if it is rusty, frayed, or damaged.

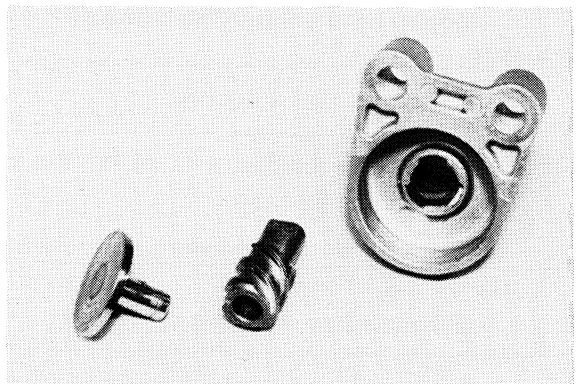

2. Replace any brake pad that is worn beyond limits. Always replace the brake pads as a set.

Wear limit: 1.5 mm (0.06 in)

3. Check for wear and deflection of the disc. If the disc is worn beyond minimum thickness or if deflection exceeds the specified amount, replace the disc.

Maximum deflection: 0.5 mm (0.02 in)
Minimum disc thickness: 3 mm (0.12 in)

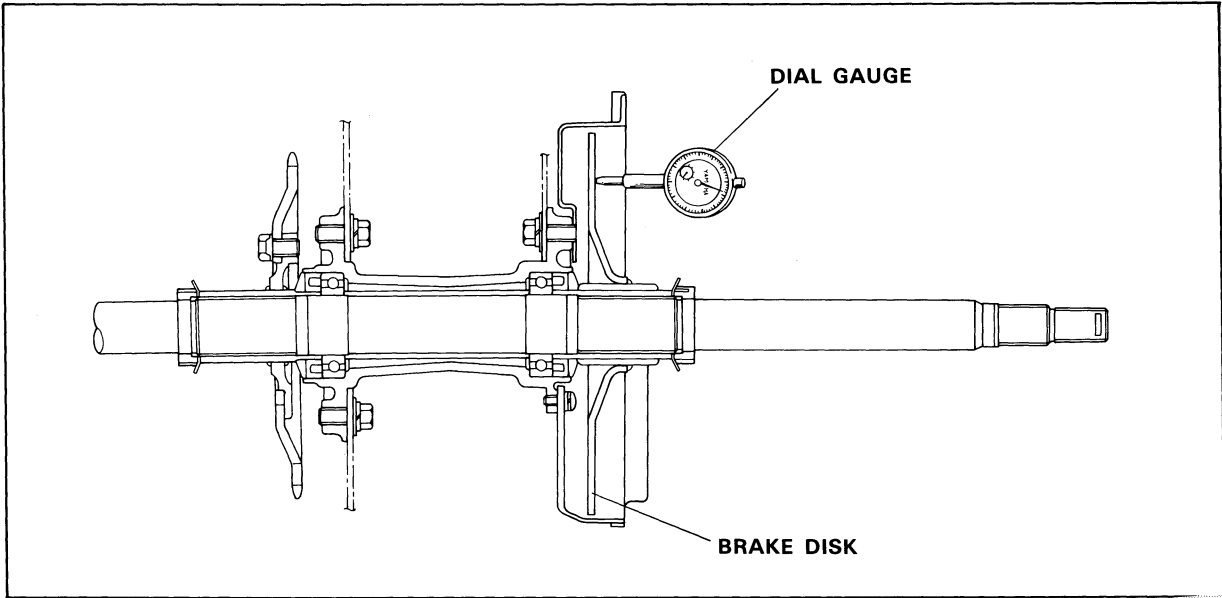

Brake assembly

1. Loosen the brake caliper adjuster lock nut and loosen the adjuster. Next, push the inner pad into the calipers by hand.

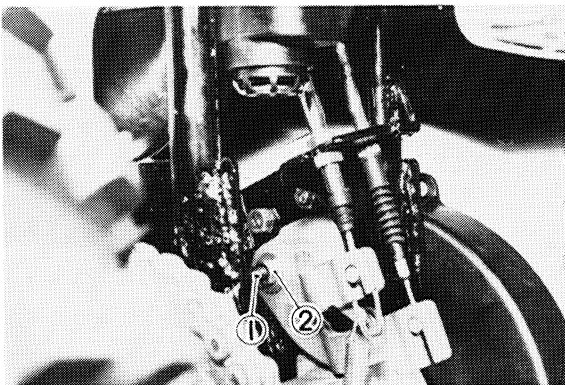

1. Adjuster 2. Lock nut

2. Grease the disc plate boss.

Recommended grease:
Medium-weight wheel bearing grease

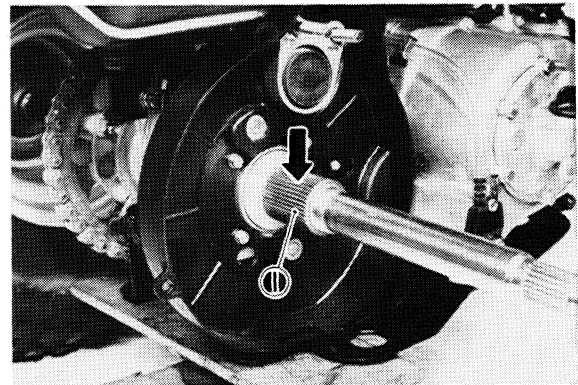

1. Disc plate boss

NOTE:

Avoid applying too much grease, or it overflows to the disc plate, thus causing brake slippage. Therefore, after greasing, install the disc plate, and slide it a few times, then wipe off the grease on the disc plate.

3. Install the disc plate and tighten the outer caliper to specification.

Tightening torque:

39 Nm (3.9 m · kg, 28 ft · lb)

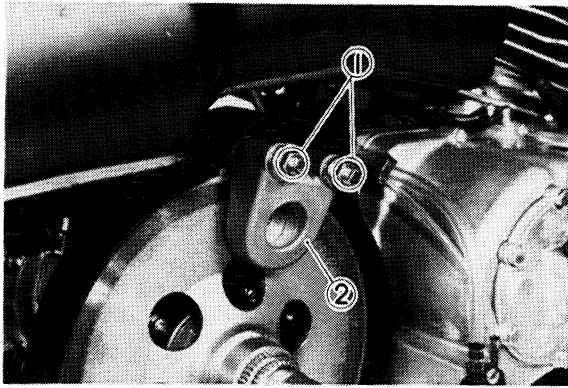

1. Caliper holding nut 2. Outer caliper

4. Tighten the ring nut to specification and lock it with the lock washer.

NOTE: _____

Always use a new lock washer.

5. Install the pad case.
6. Adjust the brake. For this adjustment, refer to page 2-9.

FRONT FORK

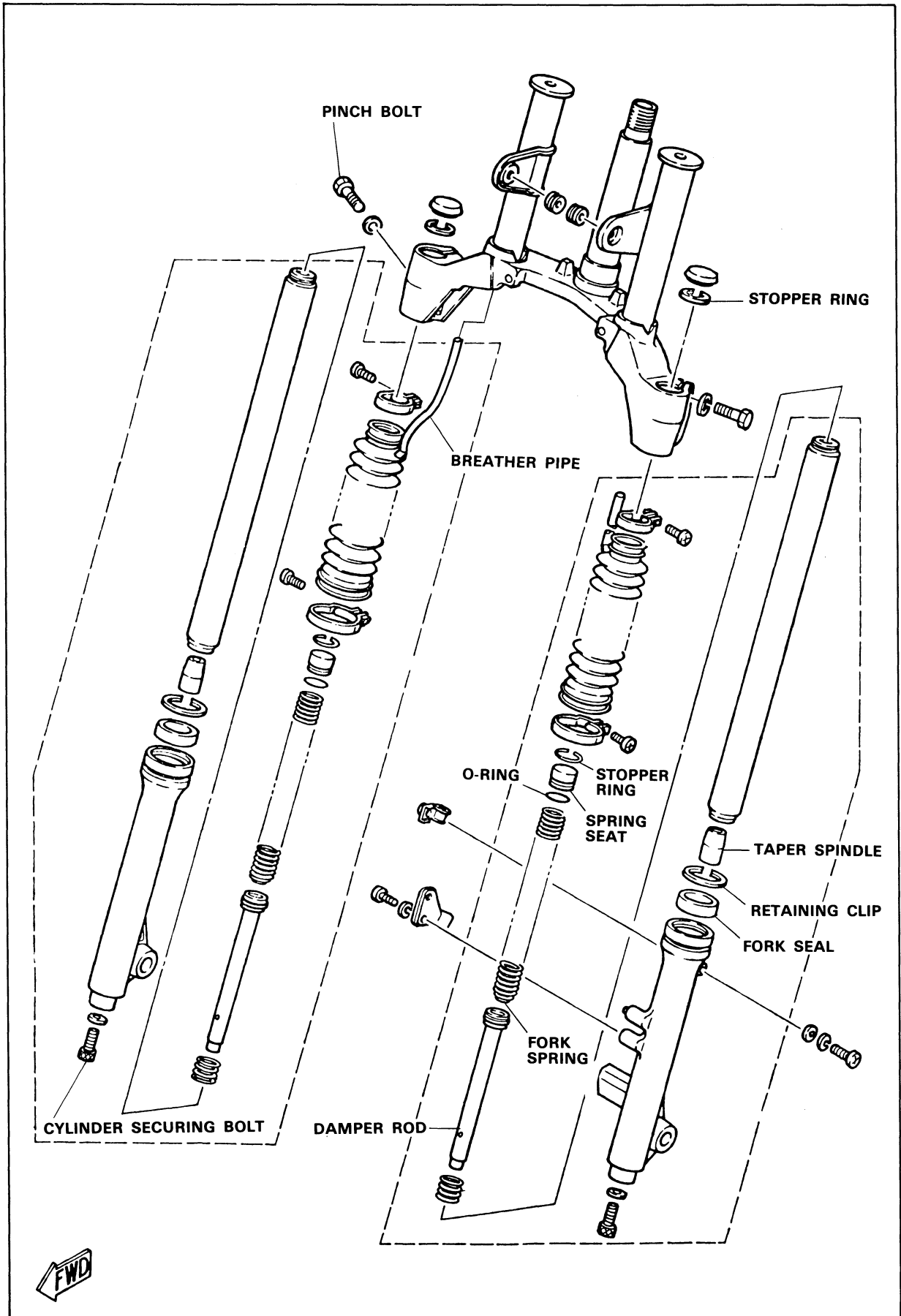

Removal and disassembly

1. Raise the front wheel by placing a suitable stand under the footrest.



2. Remove the front wheel assembly. Refer to "Front wheel removal" on page 5-1.
3. Loosen the pinch bolts and remove the brake cable holder securing bolt.

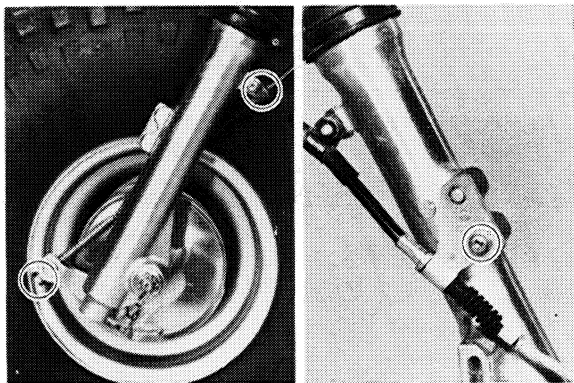
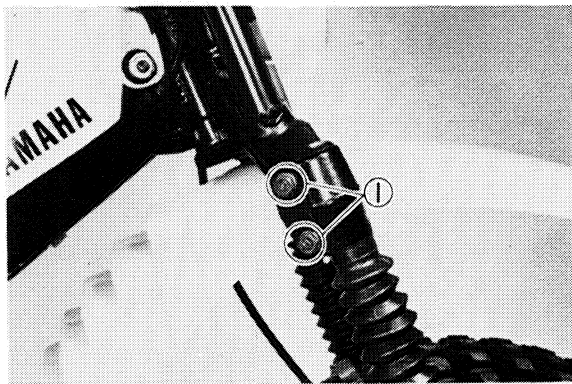

4. Remove the rubber cap and stopper ring (Spring wire circlip) from the top of the each fork.
5. The spring seat and fork spring are retained by a stopper ring (Spring wire circlip). It is necessary to depress the spring seat and fork spring to remove the stopper ring. Remove the stopper ring by carefully prying out one end with a small screwdriver.

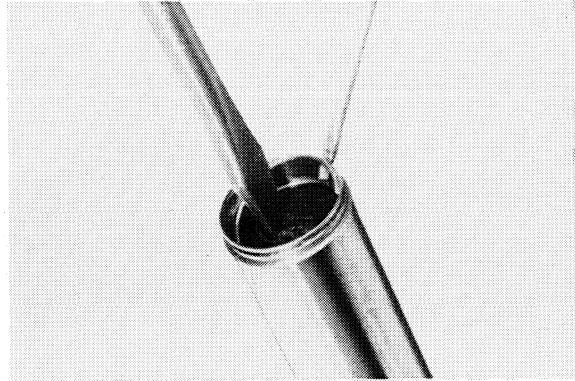

6. Remove the fork spring and drain the oil completely.
7. Remove the cylinder securing bolt from the bottom of the fork assembly. Hold the inner tube with the front fork cylinder holder. Pull the inner fork tube from the outer fork tube.

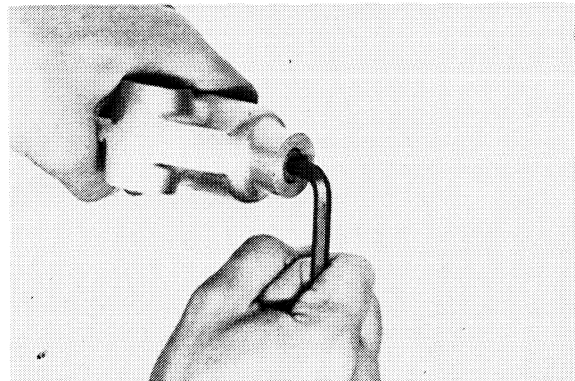

1. Cylinder securing bolt

- Remove the retaining clip from the outer fork tube, and pry out the fork seal. Be careful not to damage the fork tube surface.

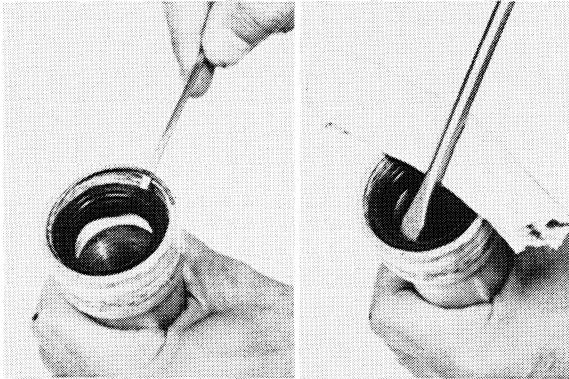

Inspection

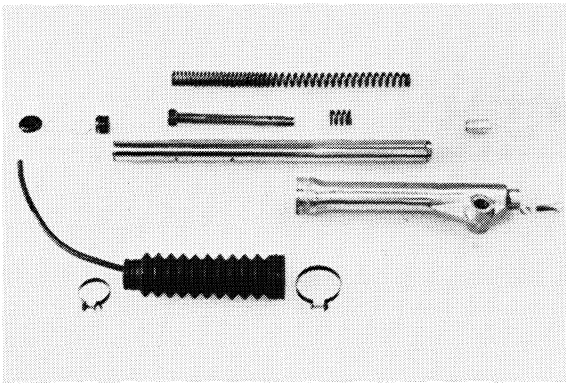

- Examine the inner fork tube. If the tube is severely scratched or bent, it should be replaced.

WARNING:

Do not attempt to straighten a bent fork tube; this may dangerously weaken the tube.

- Inspect the outer surface of the fork seal in the outer fork tube. If this surface is damaged, replace the outer fork tube. If it is not damaged, replace the fork seal.
- Check the outer fork tubes for bents. Replace the tube if it is bented.
- Check the free length of the springs.

Fork spring free length:
341.1 mm (13.43 in)

- Check the O-ring on the spring seat. If it's damaged, replace it.

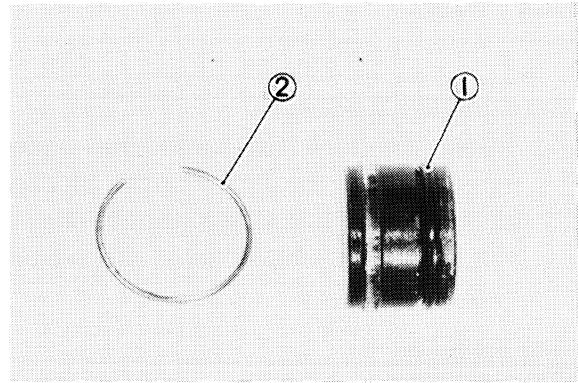

Assembly

- Make sure all components are clean before assembly. Always install a new fork seal. Do not reuse a seal.
- Apply oil to the fork seal, and install the fork seal by pressing it in with a large socket. Install the retaining clip.
- Install the inner fork tube into the outer fork tube.
- Apply locktite® Stud N' Bearing Mount (red) to the cylinder securing bolt, and install the bolt and a copper washer into the outer fork tube. Torque the bolt specification.

Tightening torque:

23 Nm (2.3 m · kg, 4.3 ft · lb)

- Pour specified amount of oil into the inner tube.

Fork oil:

Yamaha fork oil 10 Wt or equivalent

Oil capacity (Each fork):

116 cm³ (4.08 Imp oz, 3.92 US oz)

Oil level: 245.5 mm (9.67 in)

(From top of inner tube fully compressed without spring)

- Reinstall the fork spring, spring seat and stopper ring by depressing the spring seat with a screwdriver.

CAUTION

Always use a new stopper ring (Spring wire circlip).

Installing the front fork

1. Insert the fork tube into the under bracket; push the fork into the bracket until it stops. Install the stopper ring in the fork tube, and reinstall the rubber cap.

CAUTION

1. Be sure the stopper ring is properly seated in the groove in the fork tube.
2. When installing the fork, make sure the breather pipe is properly connected and routed.

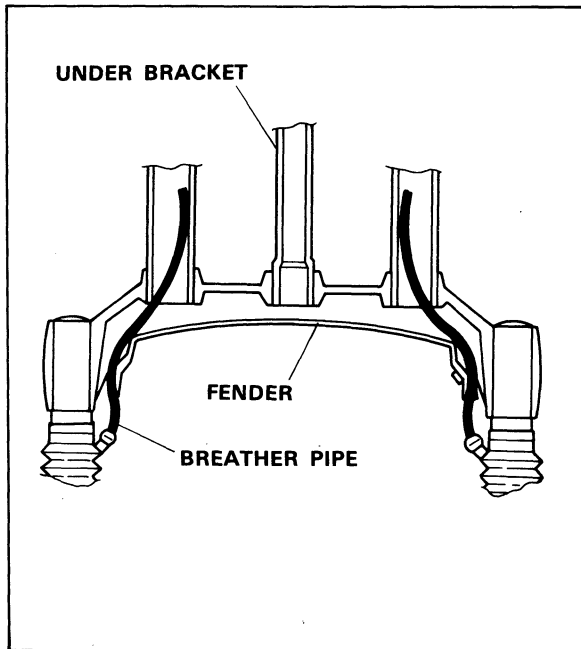

2. Install the pinch bolts and tighten them to specification.

Tightening torque:

54 Nm (5.4 m · kg, 39 ft · lb)

3. Reinstall the front wheel.
Refer to "Installing the front wheel" on page 5-2.

Adjustment

Refer to "Assembly" for steering head adjustment procedures on page 2-11.

Removal

1. Remove the front panel, headlight unit, and disconnect all wiring connectors in the headlight shell.
2. Remove the front wheel and front fender.
3. Remove the handlebar holder bolts and handlebar.
4. Remove the cap bolts, stem nut, and remove the steering crown.

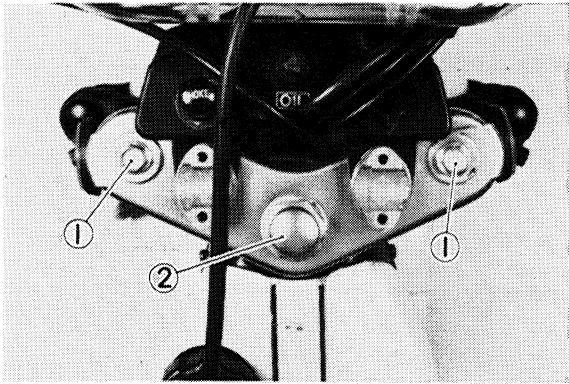

1. Cap bolt 2. Steering stem nut

5. Remove the steering nut and ball race cover.

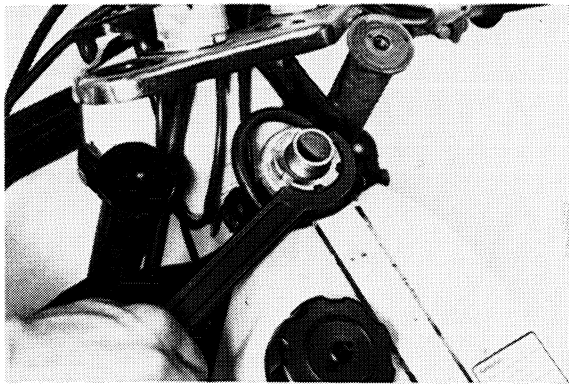

1. Steering nut wrench

6. Remove the under bracket with front fork assembly.

Ball quantity:

Upper: 22 pcs
Lower: 19 pcs

Inspection

1. Wash the bearing in solvent.
2. Inspect the bearings for pitting or other damage. Replace the bearings if pitted or damaged. Replace the race when the balls are replaced.
3. Clean and inspect the bearing races. Spin the bearings by hand. If the bearings are not smooth in their operation, replace balls and races.

Assembly

1. Grease the bearings and races with wheel bearing grease.

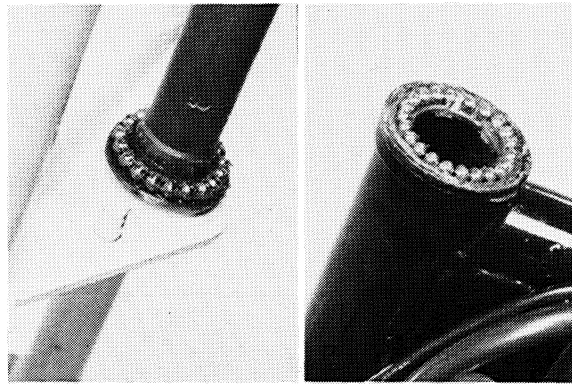

2. Install the steering stem, balls, and races.
3. Install the steering fitting nut. Tighten it to approximately 25 Nm (2.5 m·kg, 18 ft·lb) and loosen it approximately 1/4 turn.

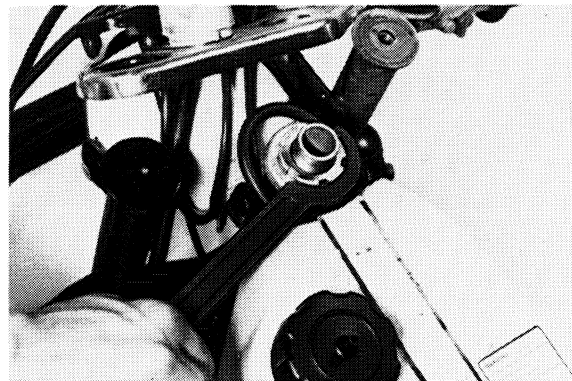

4. Continue assembly; reverse the disassembly procedure.

- When assembly is complete, check the steering stem by turning it from lock to lock. If there is any binding or looseness, readjust the tightness of the steering stem.

Tightening torque:

Steering stem nut:

65 Nm (6.5 m · kg, 47 ft · lb)

Cap bolt:

50 Nm (5.0 m · kg, 36 ft · lb)

Handle holder bolt:

34 Nm (3.4 m · kg, 24.5 ft · lb)

DRIVE CHAIN AND SPROCKETS

Adjustment

Refer to "Drive chain adjustment" on page 2-11.

Sprocket inspection

- Check sprocket wear. Replace if tooth width has decreased as shown.

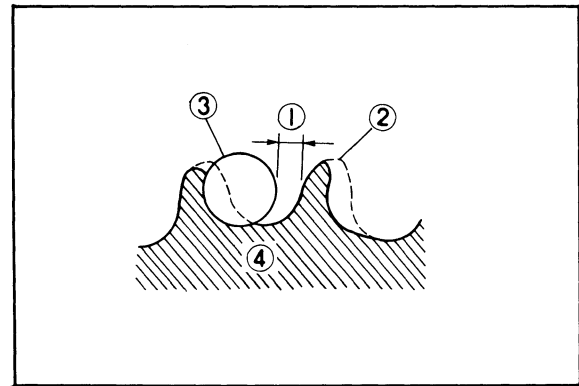

1. 1/4 tooth 2. Correct 3. Roller 4. Sprocket

- Replace if tooth wear shows a pattern such as that in the illustration or similar wear.

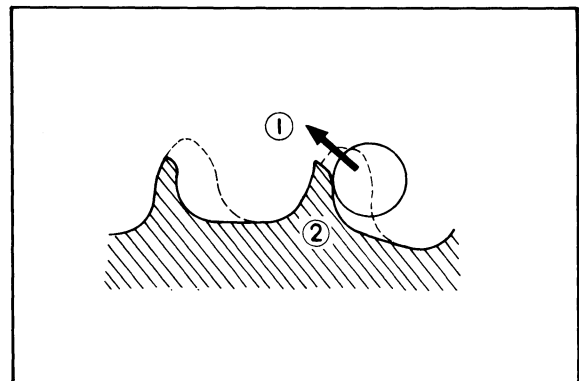

Removal

1. Elevate the rear wheel by placing a suitable stand under the engine.
2. Remove the cotter pin and axle nut from the left side of rear wheel.

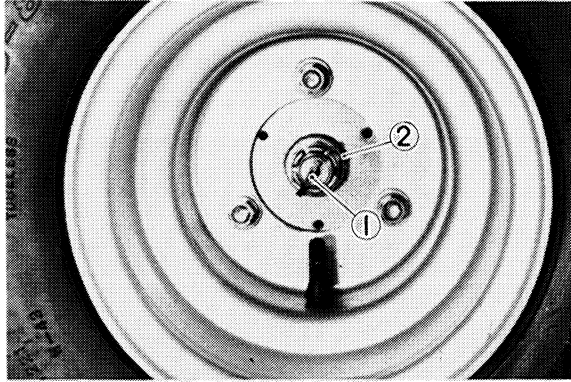

1. Cotter pin 2. Axle nut

3. Remove the wheel. Make sure the machine is properly supported.
4. Loosen the rear wheel hub bolts and chain adjuster.

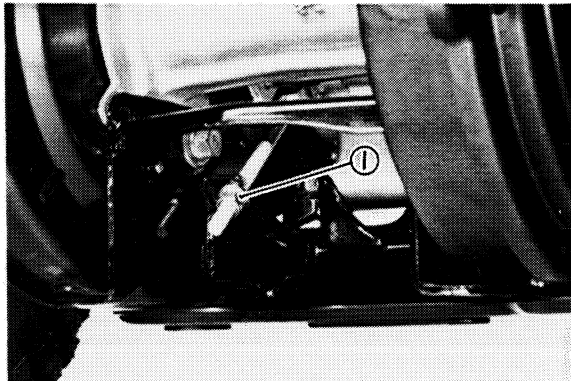

1. Adjuster

5. Remove the drive sprocket nut and ring nut. Next, remove the drive sprocket, driven sprocket and chain together.

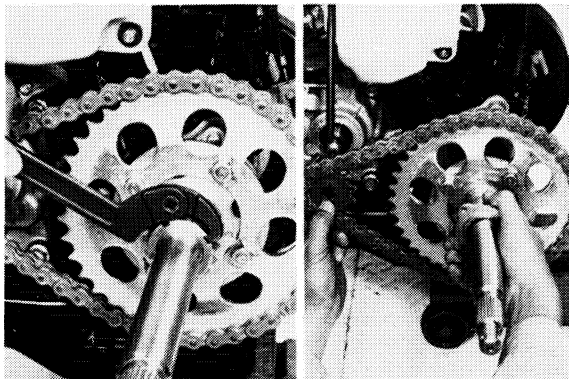

Assembly

1. Install the drive sprocket, driven sprocket and drive chain together. Torque the drive sprocket nut and ring nut to specification. Bend a lock tab against a nut flat.

Drive sprocket nut:

55 Nm (5.5 m · kg, 40 ft · lb)

Ring nut:

135 Nm (13.5 m · kg, 98 ft · lb)

2. Install the chain case.
3. Adjust the drive chain. Refer to "Drive chain adjustment" on page 2-11.
4. Install the wheel. Tighten the axle nut and install a new cotter pin.

Tightening torque:

110 Nm (11 m · kg, 80 ft · lb)

Drive chain cleaning and lubrication

See "Drive chain lubrication" on page 2-11.

CABLES AND FITTINGS

Cable maintenance

NOTE: _____

See maintenance and Lubrication Interval Charts for additional information.

Cable maintenance is primarily concerned with preventing deterioration through rust and weathering; and assuring that the cable moves freely within its housing.

Cable removal is straightforward and uncomplicated. Removal will not be discussed within this section. For details, see the individual maintenance section for which the cable is an integral part.

Cable routing is very important however. For details of cable routing, see the cable routing diagrams at the end of this manual.

1. Remove the cable.
2. Check for free movement of cable within its housing. If movement is obstructed, check for fraying or kinking of the cable strands. If damage is evident, replace the cable assembly.
3. To lubricate cable, hold in a vertical position. Apply lubricant to uppermost end of cable. Leave in a vertical position until lubricant appears at bottom end. Allow excess to drain and re-install.

NOTE: _____

Choice of lubricant depends upon conditions and preference. However, a semi-drying chain and cable lubricant will probably perform adequately under most conditions.

CHAPTER 6. ELECTRICAL

IGNITION SYSTEM	6-1
Checking the magneto charge coil and pick up coil	6-2
Ignition timing	6-2
Spark gap test	6-2
Ignition coil resistance test	6-2
Spark plug	6-3
LIGHTING AND SIGNAL SYSTEMS	6-3
Lighting tests and checks	6-3

ELECTRICAL

IGNITION SYSTEM

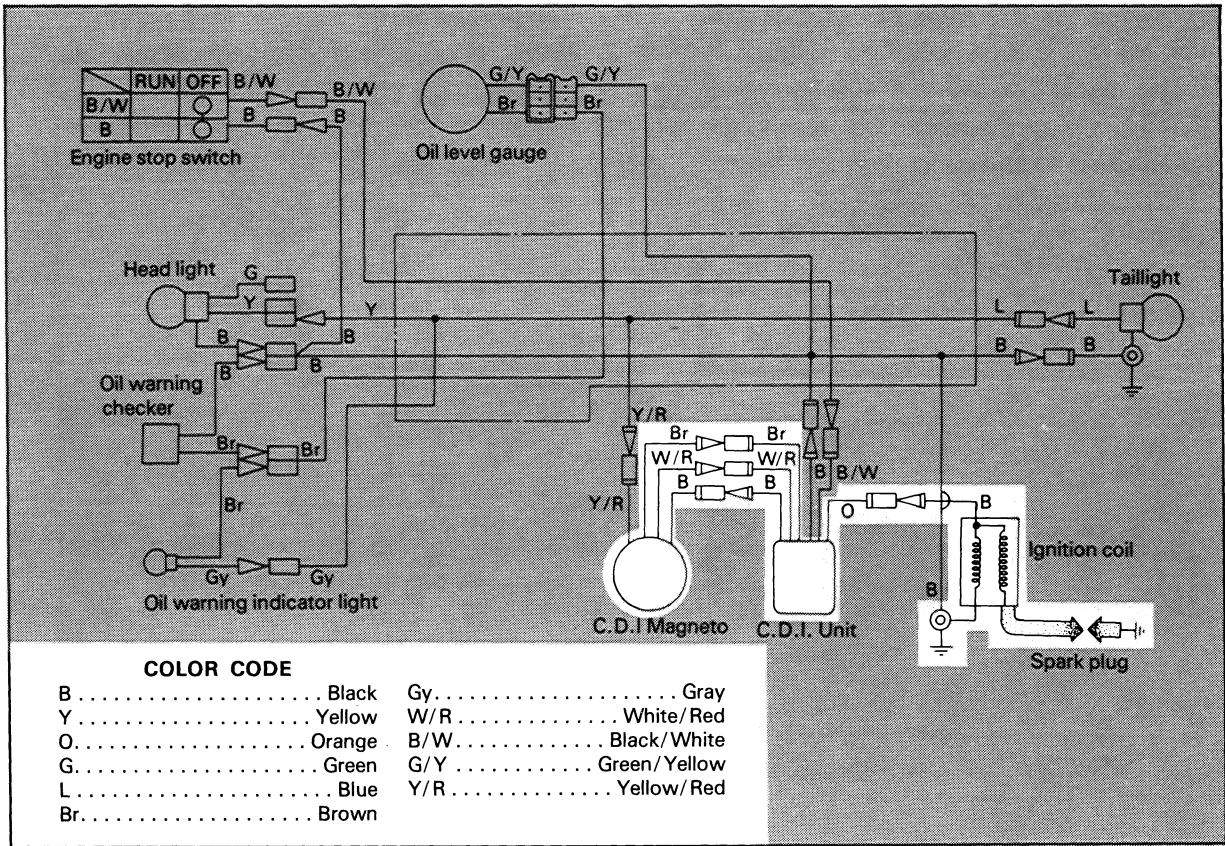

This circuit diagram shows the ignition circuit in the wiring diagram.

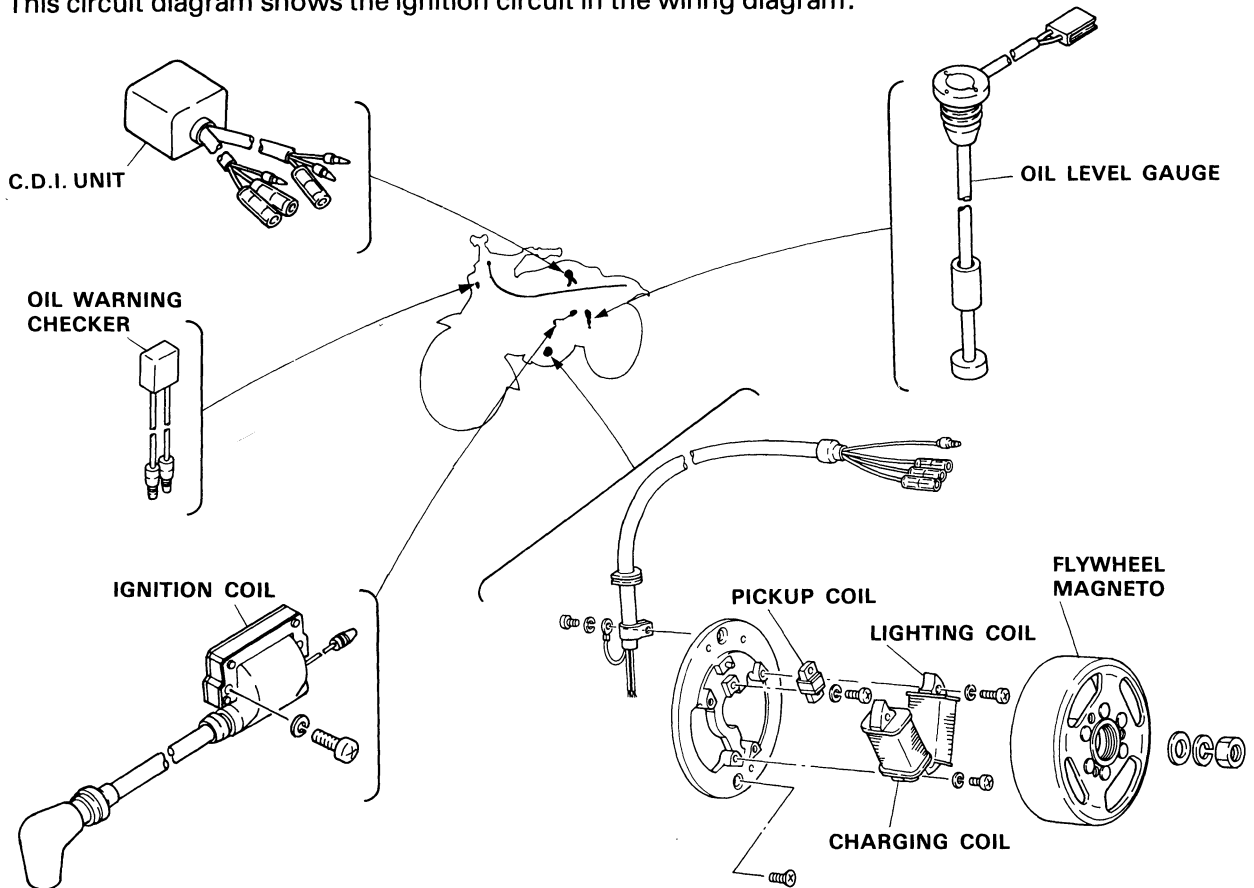

Checking the magneto charge coil and pick up coil

The resistance of the magneto charge coil and pick up coil are as specified below. To locate the cause of trouble (broken coil, short-circuit etc.), measure the resistance across each lead as shown in chart.

Pick up coil Color	10Ω ± 10% at 20°C (68°F) (W/R – B)
Charge coil Color	300Ω ± 10% at 20°C (68°F) (Br – B)

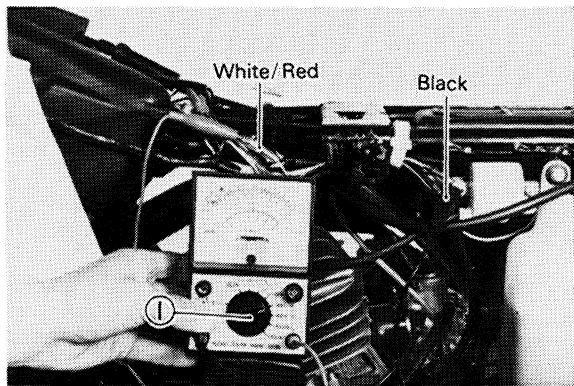

1. Set the tester "× 10Ω" position

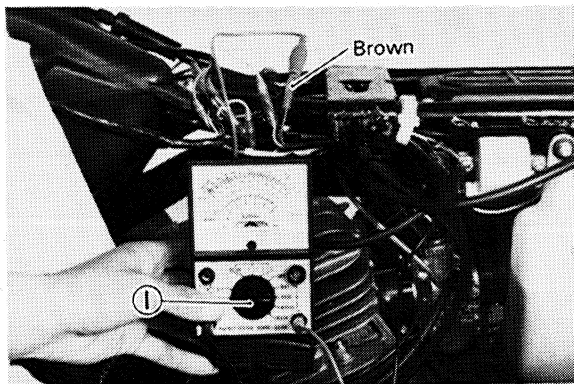

1. Set the tester "× 10Ω" position

Ignition timing

See page 2-7 for Ignition timing.

Spark gap test

The entire ignition system can be checked for misfire and weak spark using the Electro Tester. If the ignition system will fire across a sufficient gap, the engine ignition system can be considered good. If not, proceed with individual component tests until the problem is found.

1. Warm up engine thoroughly so that all electrical components are at operating temperature.
2. Stop engine and connect tester as shown.

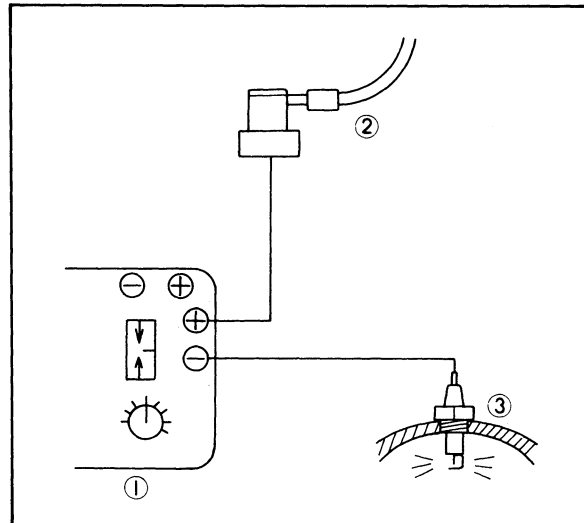

1. Electro-tester
2. Plug wire from coil
3. Spark plug

3. Start engine and increase spark gap until misfire occurs. (Test at various rpm's between idle and red line.)

Minimum spark gap:
9 mm (0.35 in) at 5,000 r/min

Ignition coil resistance test

Use a Pocket Tester or equivalent ohmmeter to determine resistance and continuity of primary and secondary coil windings.

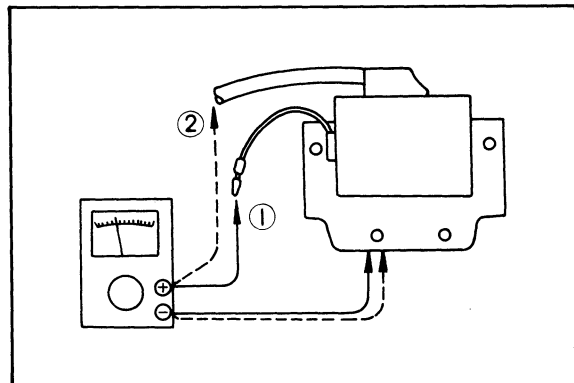

1. Primary coil resistance check.
2. Secondary coil resistance check.

Primary coil resistance	Secondary coil resistance
Set the tester "× 1Ω" position	Set the tester "× 100Ω" position
1.0Ω ± 10% at 20°C (68°F)	5.9KΩ ± 20% at 20°C (68°F)

Spark plug

The life of a spark plug and its discoloring vary according to the habits of the rider. At each periodic inspection, replace burned or fouled plugs with suitable ones determined by the color and condition of the bad plugs. One machine may be ridden only in urban areas at low speeds; another may be ridden for hours at high speed. Confirm what the present plugs indicate by asking the rider how long and how fast the rides. Recommend a hot, standard, or cold plug type accordingly. It is actually economical to install new plugs often since it will tend to keep the engine in good condition and prevent excessive fuel consumption.

1. How to "read" a spark plug (condition)
 - a. Best condition: When the porcelain around the center electrode is a light tan color.
 - b. If the electrodes and porcelain are black and somewhat oily, replace the plug with a hotter type for low speed riding.
 - c. If the porcelain is burned or glazed white and/or the electrodes are partially burned away, replace the plug with a colder type for high speed riding.

NOTE:

First check for ignition timing and intake air leaks before changing spark plug types.

2. Inspection

Instruct the rider to:

- a. Inspect and clean the spark plug at least every 6 months.
- b. Clean the electrodes of carbon and adjust the electrode gap.
- c. Be sure to use the proper reach plug as a replacement to avoid overheating, fouling or piston damage.

Spark plug type: BP7ES (NGK)
Spark plug gap: (use wire gap gauge) 0.7 ~ 0.8 mm (0.028 ~ 0.031 in)

LIGHTING AND SIGNAL SYSTEMS

Lighting tests and checks

1. A.C. Circuit Output Test

With all A.C. lights in operation the circuit will be balanced and the voltage will be the same at all points at a given r/min.

- a. Switch Pocket Tester to "AC20V" position.
- b. Connect positive (+) test lead to Yellow connection and negative (-) test lead to a good ground.

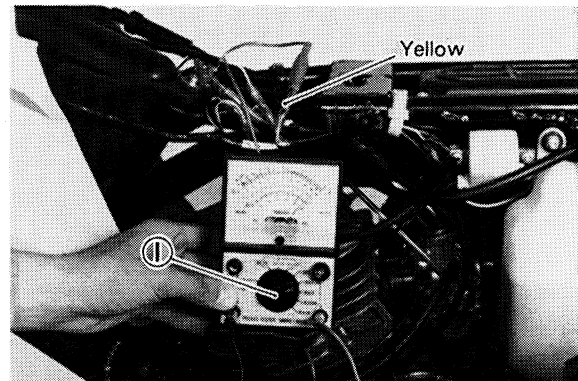

1. Set the tester "AC20V" position

- c. Start engine, turn on lights and check voltage at each engine speed.

If measured voltage is too high or too low, check for bad connections, damaged wires, burned out bulbs or bulb capacities that are too large throughout the A.C. lighting circuit.

Output voltage:

6.0V or more/3,000 r/min

8.3V or less/8,000 r/min

Color: (Y — B)

NOTE:

This voltage test can be made at any point throughout the A.C. lighting circuit and the readings should be the same as specified above.

2. Lighting Coil Resistance Check

If voltage is incorrect in A.C. lighting circuit, check the resistance of the Yellow/Red wire windings of the lighting coil.

- a. Switch Pocket Tester to " $\times 1\Omega$ " position and zero meter.
- b. Connect positive (+) test lead to Yellow/Red wire from magneto and negative (-) test lead to good ground on engine. Read the resistance on ohms scale.

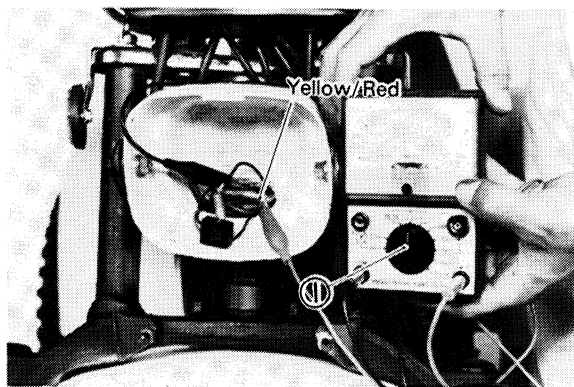

1. Set the tester " $\times 1\Omega$ " position

Lighting coil resistance:

$0.46\Omega \pm 10\% / 20^{\circ}\text{C} (68^{\circ}\text{F})$

Color: (Y/R — B)

CHAPTER 7. APPENDICES

SPECIFICATIONS	7-1
GENERAL TORQUE SPECIFICATIONS	7-9
DEFINITIONS OF UNITS	7-9
CONVERSION TABLES.....	7-10
EXPLODED DIAGRAMS.....	7-11
CYLINDER HEAD/CYLINDER	7-11
CRANKSHAFT/CONNECTING ROD/PISTON	7-12
CRANKCASE	7-13
TRANSMISSION.....	7-14
CLUTCH.....	7-15
SHIFT CAM/FORK.....	7-16
SHIFT SHAFT/PEDAL.....	7-17
STEERING	7-18
FRONT FORK	7-19
FRONT WHEEL.....	7-20
REAR WHEEL.....	7-21
ELECTIRCAL	7-22
CABLE ROUTING	7-23
YT175J WIRING DIAGRAM	

SPECIFICATIONS

I. GENERAL SPECIFICATIONS

Model	YT175J
Model Code Number	5V7
Frame Starting Number	5V7-000101
Engine Starting Number	5V7-000101
Dimensions:	
Overall Length	1,690 mm (66.5 in)
Overall Width	995 mm (39.2 in)
Overall Height	950 mm (37.4 in)
Seat Height	690 mm (27.2 in)
Wheelbase	1,130 mm (44.5 in)
Minimum Ground Clearance	120 mm (4.7 in)
Basic Weight:	
With Oil and Full Fuel Tank	126 kg (227 lb)
Minimum Turning Radius	2,100 mm (83 in)
Engine:	
Engine Type	Air cooled 2-stroke, gasoline, torque induction
Cylinder Arrangement	Single, cylinder Forward inclined
Displacement	171 cm ³
Bore × Stroke	66 × 50 mm (2.6 × 2.0 in)
Compression Ratio	5.2 : 1
Compression Pressure	883 kPa (9.0 kg/cm ² , 128 psi) at 200 r/min
Starting System	Recoil starter
Lubrication System:	Separate lubrication (Yamaha Autolube)
Oil Type or Grade:	
Engine Oil	Yamalube 2-cycle oil or Air cooled 2-stroke engine oil
Transmission Oil	Yamalube 4-cycle oil or SAE 10W 30 type SE motor oil or GL gear oil
Oil Capacity:	
Oil Tank (Engine Oil)	1.3 L (1.14 Imp qt, 1.37 US qt)
Transmission Oil	
Periodic Oil Change	0.7 ~ 0.8 L (0.6 ~ 0.7 Imp qt, 0.7 ~ 0.8 US qt)
Total Amount	0.8 ~ 0.9 L (0.70 ~ 0.8 Imp qt, 0.8 ~ 1.0 US qt)
Air Filter:	Wet type element

Model	YT175J
Fuel: Type Tank Capacity Reserve Amount	Regular gasoline 8.4 L (1.9 Imp gal, 2.2 US gal) 1 L (0.9 Imp gal, 0.6 US gal)
Carburetor: Type Manufacturer	VM24SS MIKUNI
Spark Plug: Type Manufacturer Gap	BP7ES NGK 0.7 ~ 0.8 mm (0.028 ~ 0.031 in)
Clutch Type:	Wet, automatic
Transmission: Primary Reduction System Primary Reduction Ratio Secondary Reduction System Secondary Reduction Ratio Transmission Type Operation Gear Ratio 1st 2nd 3rd 4th 5th	Gear 68/25 (2.720) Chain drive 39/11 (3.545) Constant mesh, 5-speed Left foot operation 35/10 (3.500) 31/14 (2.214) 28/18 (1.556) 25/21 (1.190) 23/23 (1.000)
Chassis: Frame Type Caster Angle Trail	Semi double cradle 23°30' 76 mm (2.99 in)
Tire: Type Size (F) Size (R)	Tubeless, With tube 22 × 11 - 8PR 22 × 11 - 8PR × 2
Tire Pressure (Cold tire): Reference Tire Pressure (F) (R) Minimum Tire Pressure (F) (R) Standard Tire Circumference (F) (R) Minimum Tire Circumference (F) (R)	14.7 kPa (0.15 kg/cm ² , 2.2 psi) ▲ 14.7 kPa (0.15 kg/cm ² , 2.2 psi) ▲ 11.8 kPa (0.12 kg/cm ² , 1.8 psi) ▲ 11.8 kPa (0.12 Kg/cm ² , 1.8 psi) ▲ 1,735 mm (68.3 in) 1,735 mm (68.3 in) 1,725 mm (67.9 in) 1,725 mm (67.9 in)
Brake: Front Brake Type Operation Rear Brake Type Operation	Drum brake Right hand operation Single, Disc brake Left hand operation, Right foot operation
Suspension: Front Suspension Rear Suspension	Telescopic fork —

Model	YT175J
Shock Absorber: Front Shock Absorber Rear Shock Absorber	Coil spring, oil damper —
Wheel Travel: Front Wheel Travel Rear Wheel Travel	100 mm (4.0 in) —
Electrical: Ignition System Generator System Battery Type or Model Battery Capacity	C.D.I. Magneto Flywheel magneto — —
Headlight Type:	Semi-sealed beam, (Bulb type)
Bulb Wattage/Quantity: Headlight Taillight	25W/25W × 1 5.3W × 1
Indicator light: Wattage/Quantity "OIL"	3W × 1

II. MAINTENANCE SPECIFICATIONS

a. Engine

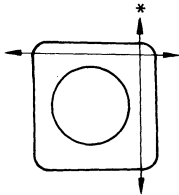
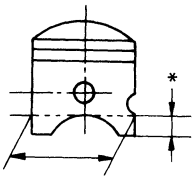
Model	YT175J
Cylinder Head: Warp Limit 	<0.05 mm (0.002 in)> * Lines indicate straightedge measurement.
Cylinder: Bore Size Taper Limit Out of Round Limit	66 mm (2.6 in) <0.05 mm (0.002 in)> <0.01 mm (0.0004 in)>
Piston: Piston Size/ Measuring Point* Piston Clearance <Limit> Oversize 1st 2nd 3rd 4th Piston offset	 66 mm (2.6 in)/ 10 mm (0.39 in) 0.040 ~ 0.045 mm (0.0016 ~ 0.0018 in) 66.25 mm (2.61 in) 66.50 mm (2.62 in) 66.75 mm (2.63 in) 67.00 mm (2.64 in) 0.5 mm (0.02 in) IN-side

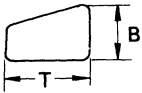
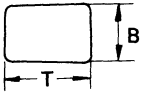
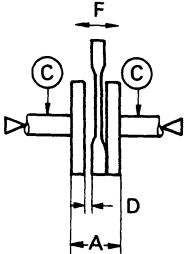
Model	YT175J
<p>Piston Ring: Sectional Sketch</p> <div style="display: flex; align-items: center; margin-bottom: 10px;">  <div> <p>Top Ring</p> </div> </div> <div style="display: flex; align-items: center;">  <div> <p>2nd Ring</p> </div> </div> <p>End Gap (Installed)</p> <p style="margin-left: 40px;">Top Ring</p> <p style="margin-left: 40px;">2nd Ring</p> <p>Side Clearance (Installed)</p> <p style="margin-left: 40px;">Top Ring</p> <p style="margin-left: 40px;">2nd Ring</p>	<p>Keystone $B = 1.5 \text{ mm (0.06 in)}$ $T = 2.5 \text{ mm (0.98 in)}$</p> <p>Plain $B = 1.5 \text{ mm (0.06 in)}$ $T = 2.5 \text{ mm (0.98 in)}$</p> <p>0.3 ~ 0.5 mm (0.012 ~ 0.020 in) 0.3 ~ 0.5 mm (0.012 ~ 0.020 in)</p> <p>0.04 ~ 0.08 mm (0.002 ~ 0.003 in) 0.04 ~ 0.08 mm (0.002 ~ 0.003 in)</p>
<p>Crankshaft:</p> <div style="text-align: center;">  </div> <p>Crank Width "A"</p> <p>Runout Limit "C"</p> <p>Connecting Rod Big End Side Clearance "D"</p> <p>Small End Free Play Limit "F"</p>	<p>$56_{-0.10}^{+0.05} \text{ mm (2.2}_{-0.004}^{+0.002} \text{ in)}$</p> <p>$<0.03 \text{ mm (0.0012 in)}>$</p> <p>0.2 ~ 0.7 mm (0.008 ~ 0.003 in)</p> <p>$<0.8 \sim 1.0 \text{ mm (0.03} \sim 0.04 \text{ in)}>$</p>
<p>Clutch:</p> <p>Friction Plate Thickness/Quantity</p> <p>Wear Limit</p> <p>Clutch Plate Thickness/Quantity</p> <p>Warp Limit</p> <p>Clutch Spring Free Length/Quantity</p> <p>Clutch Adjust Gap</p> <p>Clutch Release Method</p> <p>Clutch-in Revolution</p> <p>Clutch-stall Revolution</p> <p>Primary Reduction Gear</p> <p>Backlash Tolerance</p>	<p>2.4 mm (0.09 in) × 8</p> <p>$<2.1 \text{ mm (0.08 in)}>$</p> <p>1.2 mm (0.047 in), 1.4 mm (0.055 in), 1.6 mm (0.063 in) × 7</p> <p>$<0.06 \text{ mm (0.002 in)}>$</p> <p>15.2 mm (0.60 in) × 8, 34.6 mm (1.36 in) × 4</p> <p>$1.6_{-0.20}^{+0.15} \text{ mm (0.063}_{-0.008}^{+0.006} \text{ in)}$</p> <p>Automatic</p> <p>2,300 ~ 2,400 r/min</p> <p>2,900 ~ 3,000 r/min</p> <p>0.05 mm (0.002 in)</p>
<p>Air Filter Oil Grade (Oiled Filter)</p>	<p>SAE 10W 30 SE motor oil</p>
<p>Carburetor:</p> <p>Type/Manufacture/Quantity</p> <p>I.D. Mark</p> <p>Main Jet (M.J.)</p> <p>Main Air Jet (M.A.J.)</p> <p>Jet Needle-clip Position (J.N.)</p> <p>Needle Jet (N.J.)</p> <p>Cutaway (C.A.)</p> <p>Pilot Jet (P.J.)</p> <p>Pilot Outlet Size (P.O.)</p> <p>Air Screw (turns out) (P.A.S.)</p>	<p>VM24SS/MIKUNI × 1</p> <p>5V700</p> <p>#165</p> <p>ø2.5</p> <p>4K4-3</p> <p>N-8</p> <p>2.5</p> <p>#40</p> <p>ø0.6</p> <p>1 and 1/4</p>

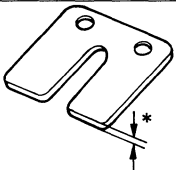
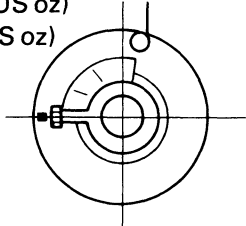
Model	YT175J
Pilot Screw (P.S.) Valve Seat Size (V.S.) Starter Jet (G.S.) Bypass Size (B.P.) Fuel Level (F.L.) Float Height (F.H.) Engine Idling Speed	$\phi 1.0$ 2.0 $\phi 1.4$ $25 \pm 1 \text{ mm } (0.98 \pm 0.04 \text{ in})$ $1,600 \pm 50 \text{ r/min}$
Reed Valve: Material Thickness* Valve Lift Bending Limit	 SUS $0.2 \text{ mm } (0.008 \text{ in})$ 9 mm (0.35 in) < $0.2 \text{ mm } (0.008 \text{ in})$ >
Lubrication System: Autolube Pump - Color Code Minimum Stroke Maximum Stroke Minimum Output/200 Stroke Maximum Output/200 Stroke Pully Adjusting Mark At idle	Separate lubrication (Yamaha autolube pump) Green $0.20 \sim 0.25 \text{ mm } (0.008 \sim 0.01 \text{ in})$ $1.85 \sim 2.05 \text{ mm } (0.07 \sim 0.08 \text{ in})$ $0.814 \text{ cm}^3 (0.18 \text{ Imp oz, } 0.03 \text{ US oz})$ $3.29 \text{ cm}^3 (0.72 \text{ Imp oz, } 0.11 \text{ US oz})$ 

Tightening Torque:	Thread Size	Nm	m · kg	ft · lb
	Engine mount — Front upper — Rear upper — Rear under	M8 M8 M10	31 31 42	3.1 3.1 4.2
Handle crown — Steering shaft — Under bracket — Handle holder	M25 M10 M10	65 34 34	6.5 3.4 3.4	47 24.5 24.5
Front wheel axle	M12	50	5.0	36
Rear wheel axle	M20 M32	110 135	11.0 13.5	80 98
Wheel nut	M10	45	4.5	32.5
Sprocket wheel	M10	45	4.5	32.5
Foot rest	M8	25	2.5	18
Brake pedal	M8	34	3.4	24.5
Rear bumper	M8	15	1.5	11

B. Chassis

Model	YT175J
Steering System: Steering Bearing Type No./Size of Steel Balls Upper Lower	Ball Bearing 22 pcs/3/16 in 19 pcs/1/4 in

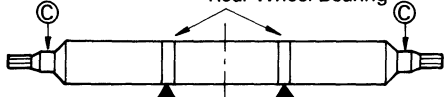
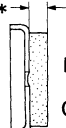
Model	YT175J
<p>Front Suspension:</p> <p>Front Fork Travel</p> <p>Fork Spring Free Length</p> <p>Spring Rate/ Stroke</p> <p>Optional Spring</p> <p>Oil Capacity or Oil Level</p> <p>Oil Grade</p>	<p>100 mm (4.0 in)</p> <p>341.1 mm (13.43 in)</p> <p>$K_1 = 4.9 \text{ N/mm}$ (0.5 kg/mm, 28 lb/in) 0 ~ 95 mm (0 ~ 3.7 in)</p> <p>$K_2 = 9.8 \text{ N/mm}$ (1 kg/mm, 56.0 lb/in) 95 ~ 100 mm (3.7 ~ 3.9 in)</p> <p>Yes</p> <p>116 cm³ (4.08 Imp oz, 3.92 US oz)</p> <p>245.5 mm (9.67 in) (From top of inner tube fully compressed without spring.)</p> <p>Yamaha fork oil (10, 15) wt</p>
<p>Rear Axle Runout Limit: Rear Wheel Bearing</p> 	<p><1.5 mm (0.06 in)></p>
<p>Wheel:</p> <p>Front Wheel Type</p> <p>Rear Wheel Type</p> <p>Front Rim Size/Material</p> <p>Rear Rim Size/Material</p> <p>Rim Runout Limit</p> <p>Vertical</p> <p>Lateral</p>	<p>Disc Wheel</p> <p>Disc Wheel</p> <p>8.25 × 8/ Steel</p> <p>8.25 × 8/ Steel</p> <p><1.0 mm (0.04 in)></p> <p><1.0 mm (0.04 in)></p>
<p>Drive Chain:</p> <p>Type/Manufacturer</p> <p>Number of Links</p> <p>Chain Free Play</p>	<p>520V/ DAIDO</p> <p>48 links</p> <p>5 ~ 10 mm (0.2 ~ 0.4 in)</p>
<p>Disc Brake:</p> <p>Type Rear</p> <p>Outside Dia. × Thickness Rear</p> <p>Pad Thickness</p> <p><Limit>  Inner</p> <p>Outer</p>	<p>Single disc</p> <p>224 × 4 mm (8.82 × 0.16 in)</p> <p>8 mm (0.3 in)</p> <p><1.5 mm (0.059 in)></p> <p>8 mm (0.3 in)</p> <p><1.5 mm (0.059 in)></p>
<p>Drum Brake:</p> <p>Type Front</p> <p>Drum Inside Dia. Front</p> <p>Lining Thickness</p> <p><Limit></p> <p>Shoe Spring Free Length Front</p>	<p>Leading trailing</p> <p>110 mm (4.33 in)</p> <p>4 mm (0.16 in)</p> <p><2 mm (0.08 in)></p> <p>34.5 mm (1.36 in)</p>
<p>Brake Lever & Brake Pedal:</p> <p>Brake Lever Free Play</p> <p>Brake Pedal Position</p> <p>Brake Pedal Free Play</p>	<p>9 ~ 15 mm (0.35 ~ 0.59 in)</p> <p>2.5 mm (0.1 in) (Vertical height below footrest top)</p> <p>6 ~ 10 mm (0.24 ~ 0.39 in) (Vertical height below footrest top)</p>

Tightening Torque:		Thread Size	Nm	m · kg	ft · lb
Cylinder head	— Nut	M8	30	3.0	22
	— Stud bolt	M8	25	2.5	18
Cylinder	— Nut	M10	35	3.5	25
	— Stud bolt	M10	45	4.5	33
Spark plug		M14	25	2.5	18
Primary drive gear	— Nut	M12	55	5.5	40
Clutch boss		M12	38	3.8	27
Drive sprocket		M16	55	5.5	40
Change pedal		M8	15	1.5	11
Generator (Rotor)		M12	70	7.0	51
	(Stator)	M6	13	1.3	10
Engine drain plug		M8	20	2.0	14.5

C. Electrical

Model	YT175J																				
Voltage:	6V																				
Ignition System: Ignition Timing (B.T.D.C.) Advancer Type	<p>$20 \pm 2^\circ$ at 2,000 r/min, 1.86 mm (0.073 in) Electrical</p> <table border="1"> <caption>Approximate data points from the Ignition Timing graph</caption> <thead> <tr> <th>Engine speed ($\times 10^3$ r/min)</th> <th>Ignition Timing (B.T.D.C.)</th> </tr> </thead> <tbody> <tr><td>0.5</td><td>10</td></tr> <tr><td>1.0</td><td>15</td></tr> <tr><td>2.0</td><td>20</td></tr> <tr><td>3.0</td><td>21</td></tr> <tr><td>4.0</td><td>20</td></tr> <tr><td>5.0</td><td>19</td></tr> <tr><td>6.0</td><td>18</td></tr> <tr><td>7.0</td><td>16</td></tr> <tr><td>8.0</td><td>14</td></tr> </tbody> </table>	Engine speed ($\times 10^3$ r/min)	Ignition Timing (B.T.D.C.)	0.5	10	1.0	15	2.0	20	3.0	21	4.0	20	5.0	19	6.0	18	7.0	16	8.0	14
Engine speed ($\times 10^3$ r/min)	Ignition Timing (B.T.D.C.)																				
0.5	10																				
1.0	15																				
2.0	20																				
3.0	21																				
4.0	20																				
5.0	19																				
6.0	18																				
7.0	16																				
8.0	14																				

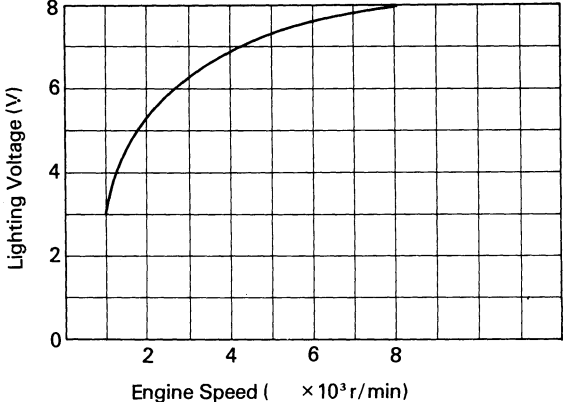
Model	YT175J
C.D.I.: Model/ Manufacture Pick up Coil Resistance Color) Charging Coil Resistance (Color) C.D.I. Unit-Model/ Manufacturer	F3T109/MITSUBISHI 10 Ω \pm 10% at 20°C (68°F) (W/R — B) 300 Ω \pm 10% at 20°C (68°F) (Br — B) 5V7/MITUBISHI
Ignition Coil-Model/ Manufacturer Minimum Spark Gap Primary Winding Resistance Secondary Winding Resistance	F6T411/MITSUBISHI 9 mm (0.35 in) at 500 r/min 1.0 Ω \pm 20% at 20°C (68°F) 5.9K Ω \pm 20% at 20°C (68°F)
Charging System: Type	Flywheel magneto
Lighting Voltage Lighting Coil Resistance (Color)	6V or more at 3,000 r/min 8.3V or less at 8,000 r/min  0.46 Ω \pm 10% at 20°C (68°F) (Y/R — B)
Oil Level Switch: Model/ Manufacturer	3E1/STANLEY

GENERAL TORQUE SPECIFICATIONS

This chart specifies torque for standard fasteners with standard I.S.O. pitch threads. Torque specifications for special components or assemblies are included in the applicable sections of this book. To avoid warpage, tighten multi-fastener assemblies in a crisscross fashion, in progressive stages, until full torque is reached. Unless otherwise specified, torque specifications call for clean, dry threads. Components should be at room temperature.

A (Nut)	B (Bolt)	General torque specifications	
		m · kg	ft · lb
10 mm	6 mm	0.6	4.3
12 mm	8 mm	1.5	11
14 mm	10 mm	3.0	22
17 mm	12 mm	5.5	40
19 mm	14 mm	8.5	61
22 mm	16 mm	13.0	94

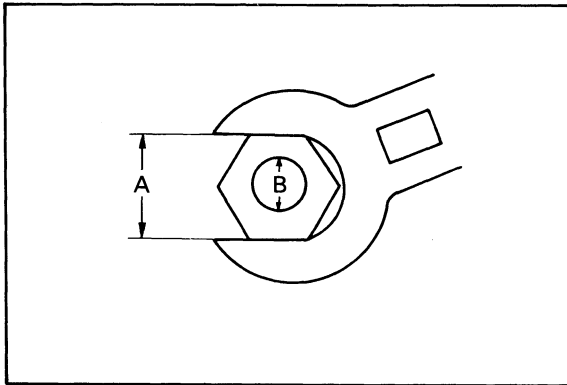

DEFINITION OF UNITS

Unit	Read	Definition	Measure
mm	millimeter	10^{-3} meter	Length
cm	centimeter	10^{-2} meter	Length
kg	kilogram	10^3 gram	Weight
N	Newton	$1 \text{ kg} \times \text{m}/\text{sec}^2$	Force
Nm	Newton meter	$\text{N} \times \text{m}$	Torque
m · kg	Meter kilogram	$\text{m} \times \text{kg}$	Torque
Pa	Pascal	N/m^2	Pressure
N/mm	Newton per millimeter	N/mm	Spring rate
L	Liter	—	Volume
cm^3	Cubic centimeter	—	or Capacity
r/min	Rotation per minute	—	Engine Speed

CONVERSION TABLES

METRIC TO INCH SYSTEM		
Known	Multiplier	Result
m · kg	7.233	ft · lb
m · kg	86.80	in · lb
cm · kg	0.0723	ft · lb
cm · kg	0.8680	in · lb
kg	2.205	lb
g	0.03527	oz
km/lit	2.352	mpg
km/hr	0.6214	mph
km	0.6214	mi
m	3.281	ft
m	1.094	yd
cm	0.3937	in
mm	0.03937	in
cc (cm ³)	0.03382	oz (US liq)
cc (cm ³)	0.06102	cu in
lit (liter)	2.1134	pt (US liq)
lit (liter)	1.057	qt (US liq)
lit (liter)	0.2642	gal (US liq)
kg/mm	56.007	lb/in
kg/cm ²	14.2234	psi (lb/in ²)
Centigrade(°C)	9/5(°C) + 32	Fahrenheit(°F)

INCH TO METRIC SYSTEM		
Known	Multiplier	Result
ft · lb	0.13826	m · kg
in · lb	0.01152	m · kg
ft · lb	13.831	cm · kg
in · lb	1.1521	cm · kg
lb	0.4535	kg
oz	28.352	g
mpg	0.4252	km/lit
mph	1.609	km/hr
mi	1.609	km
ft	0.3048	m
yd	0.9141	m
in	2.54	cm
in	25.4	mm
oz (US liq)	29.57	cc (cm ³)
cu in	16.387	cc (cm ³)
pt (US liq)	0.4732	lit (liter)
qt (US liq)	0.9461	lit (liter)
gal (US liq)	3.785	lit (liter)
lb/in	0.017855	kg/mm
psi (lb/in ²)	0.07031	kg/cm ²
Fahrenheit(°C)	5/9(°F - 32)	Centigrade(°F)

EXPLODED DIAGRAMS

CYLINDER HEAD/CYLINDER

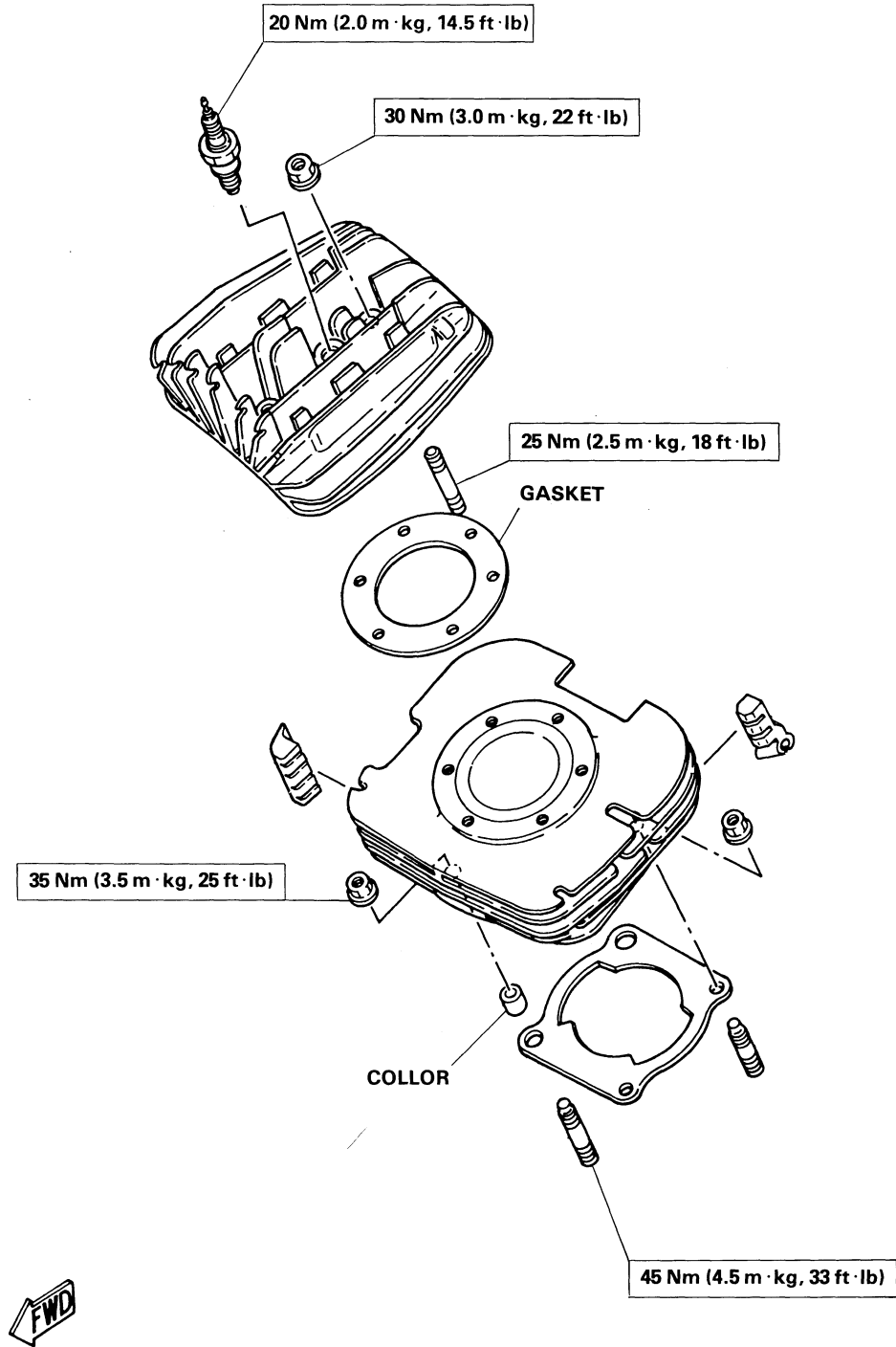

CRANKSHAFT/CONNECTING ROD/PISTON

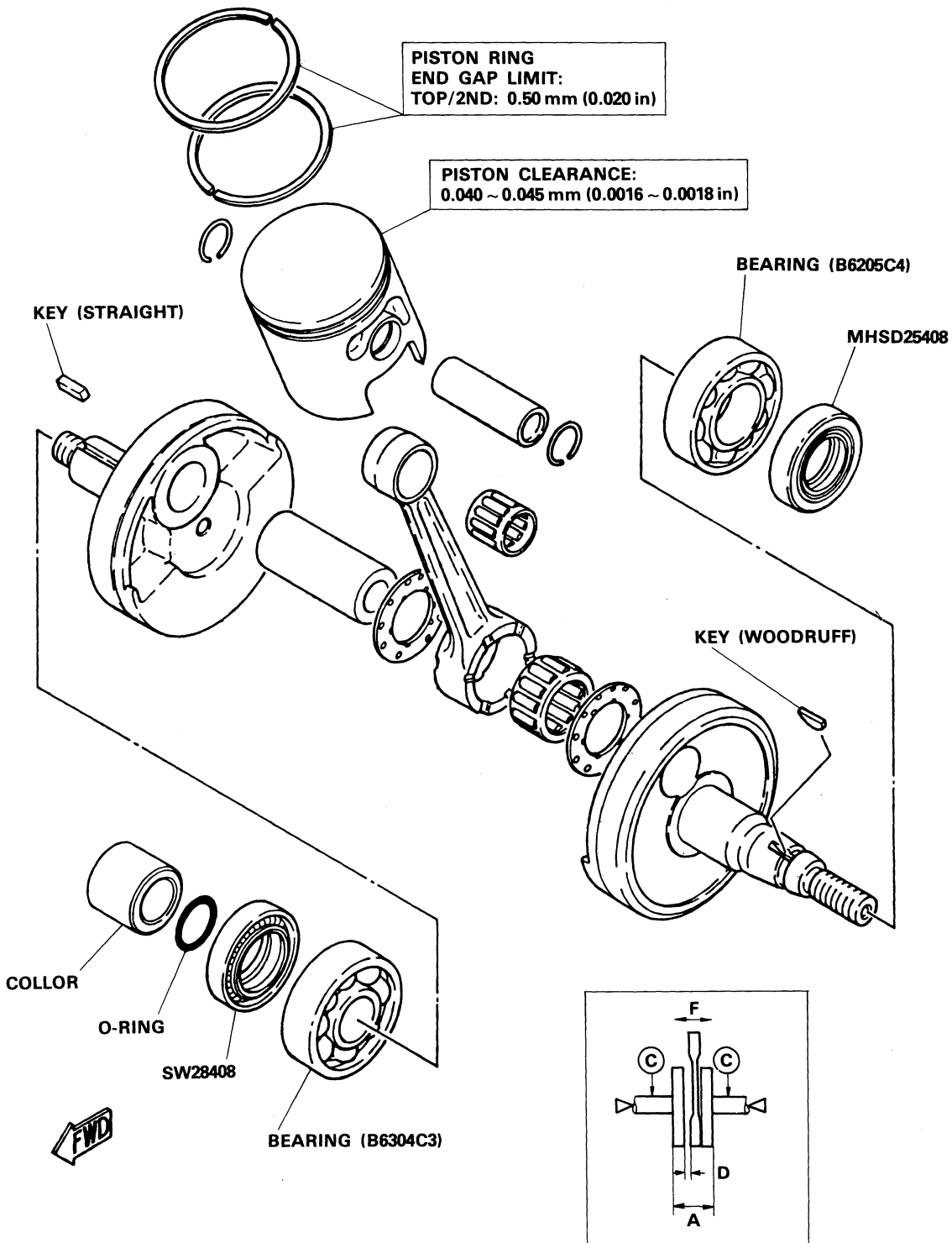

CRANK WIDTH "A": $56 \begin{smallmatrix} 0 \\ -0.05 \end{smallmatrix}$ mm ($2.2 \begin{smallmatrix} 0 \\ -0.002 \end{smallmatrix}$ in)
 RUNOUT LIMIT "C": <0.03 mm (0.0012 in)

CRANKCASE

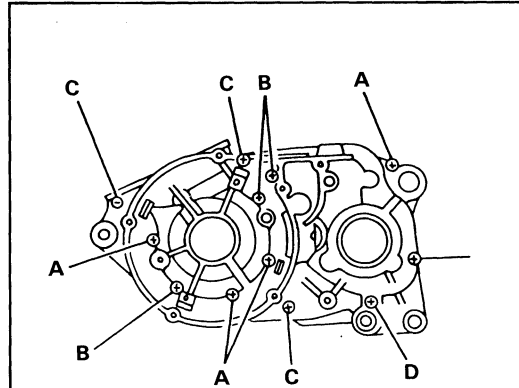

PANHEAD SCREW:

Bolt	Thread size	Length
A	M6	50 mm (2.0 in)
B	M6	60 mm (2.4 in)
C	M6	70 mm (2.8 in)
D	M6	75 mm (3.0 in)

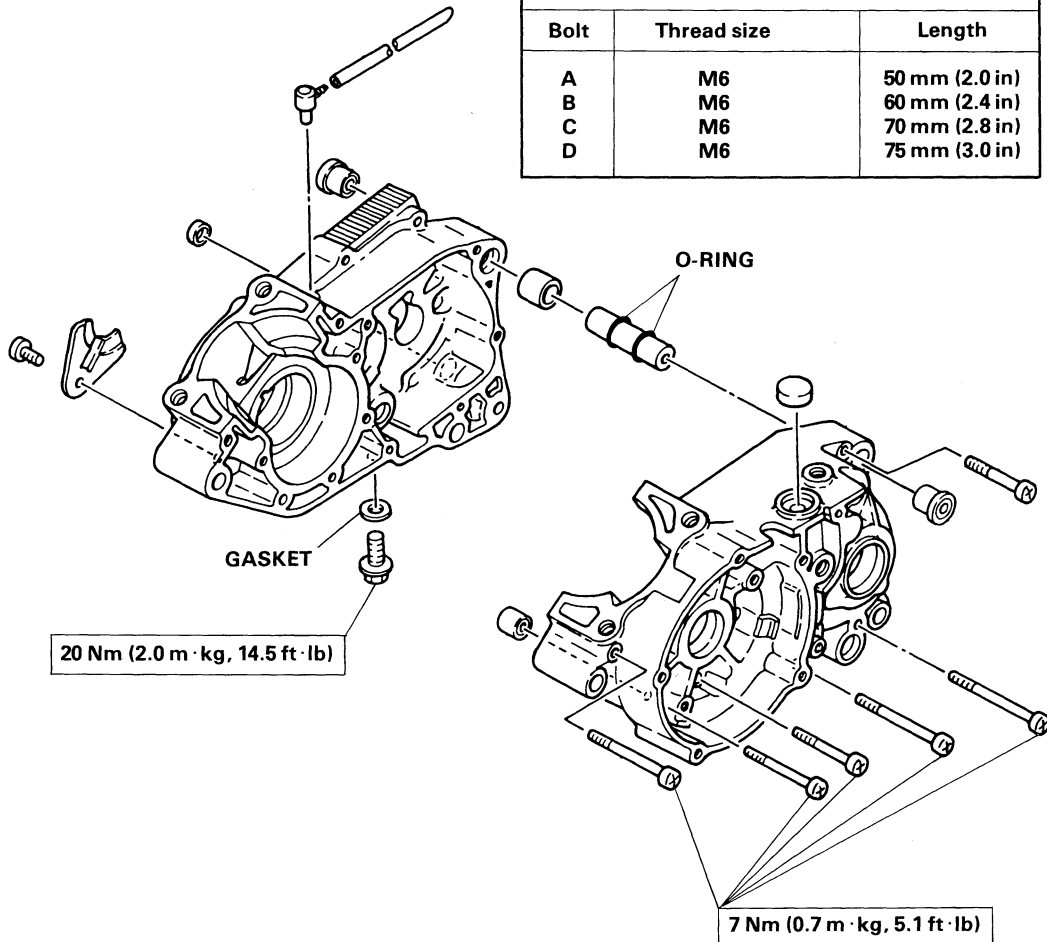

TRANSMISSION

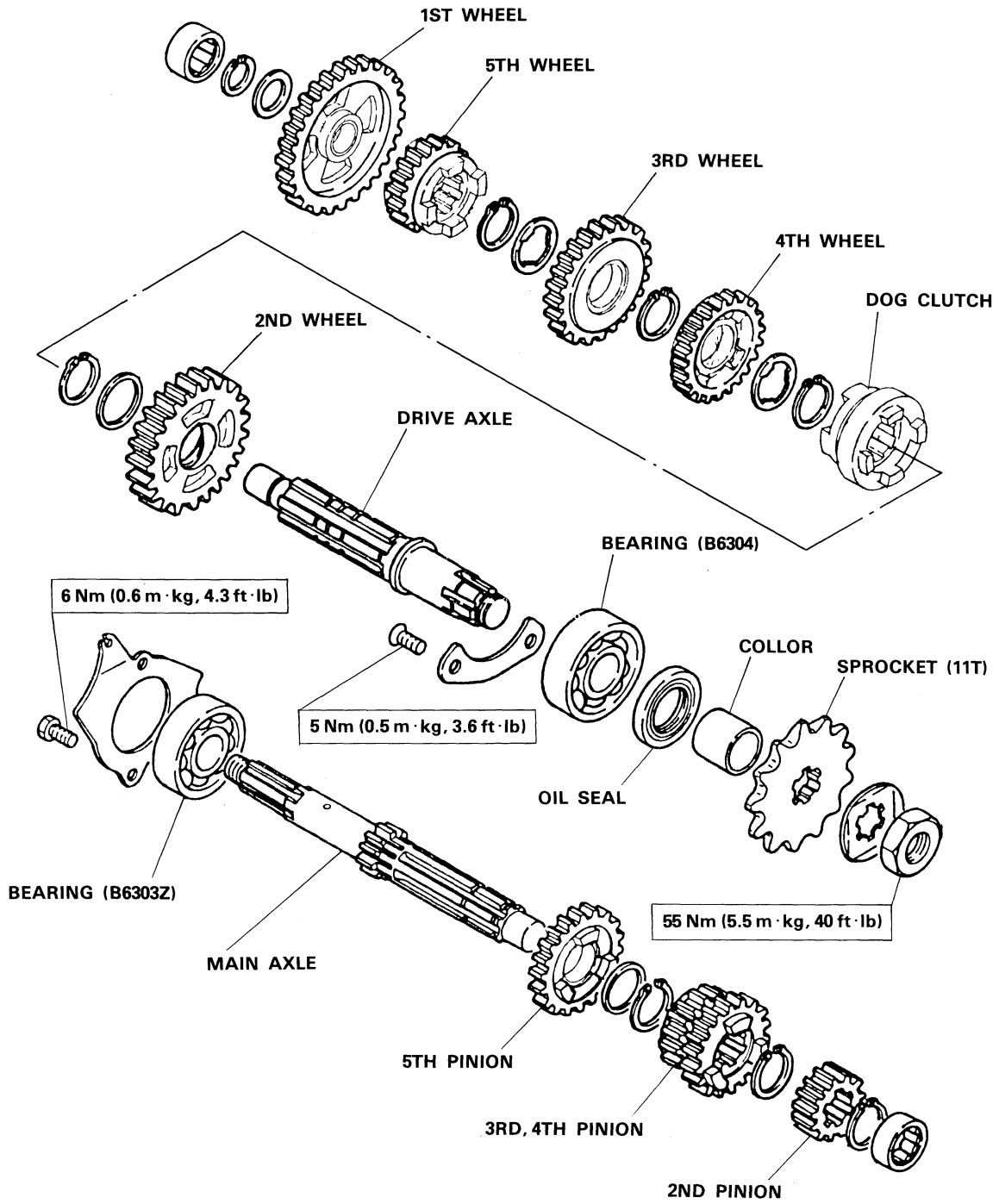

CLUTCH

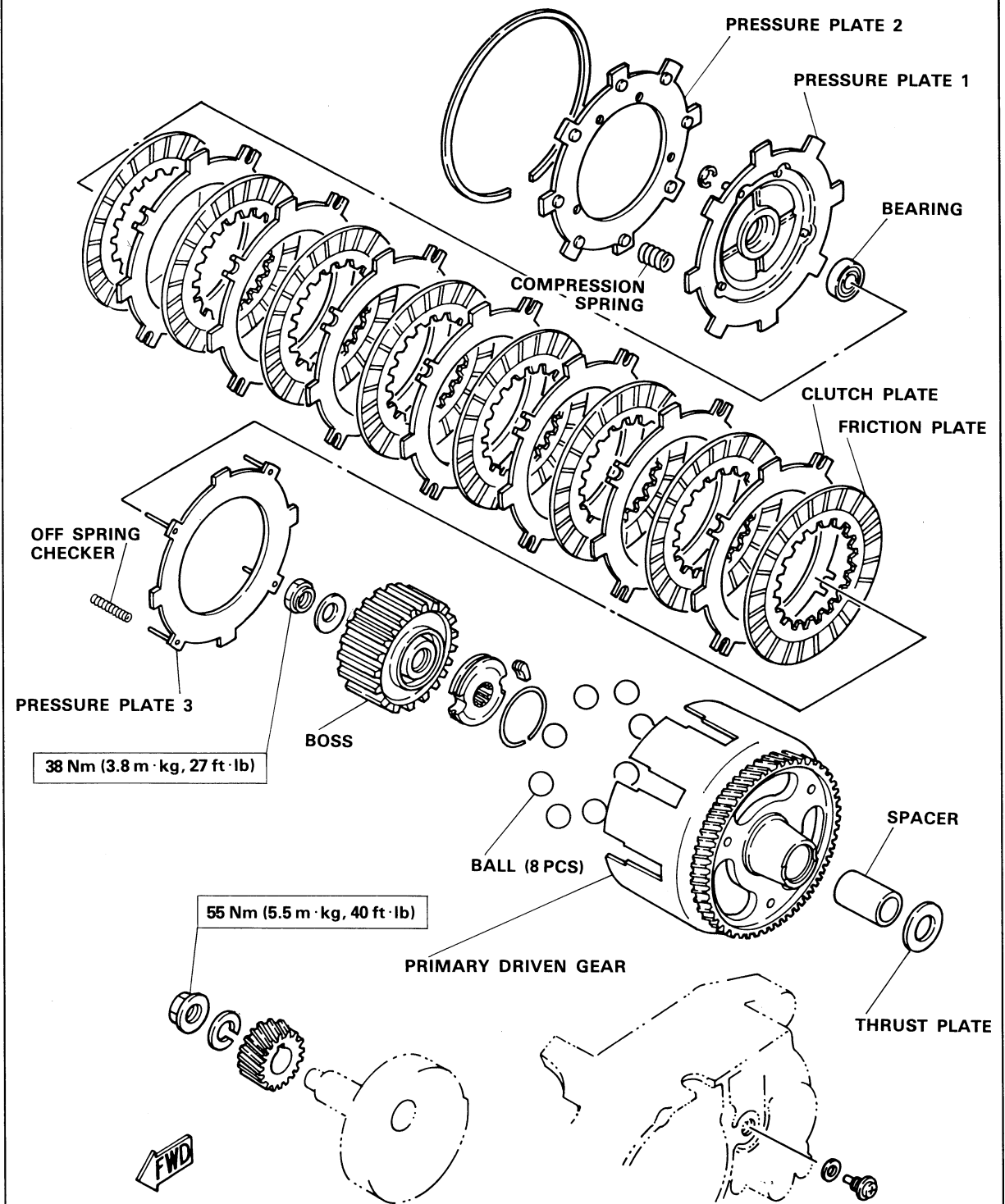

SHIFT CAM/FORK

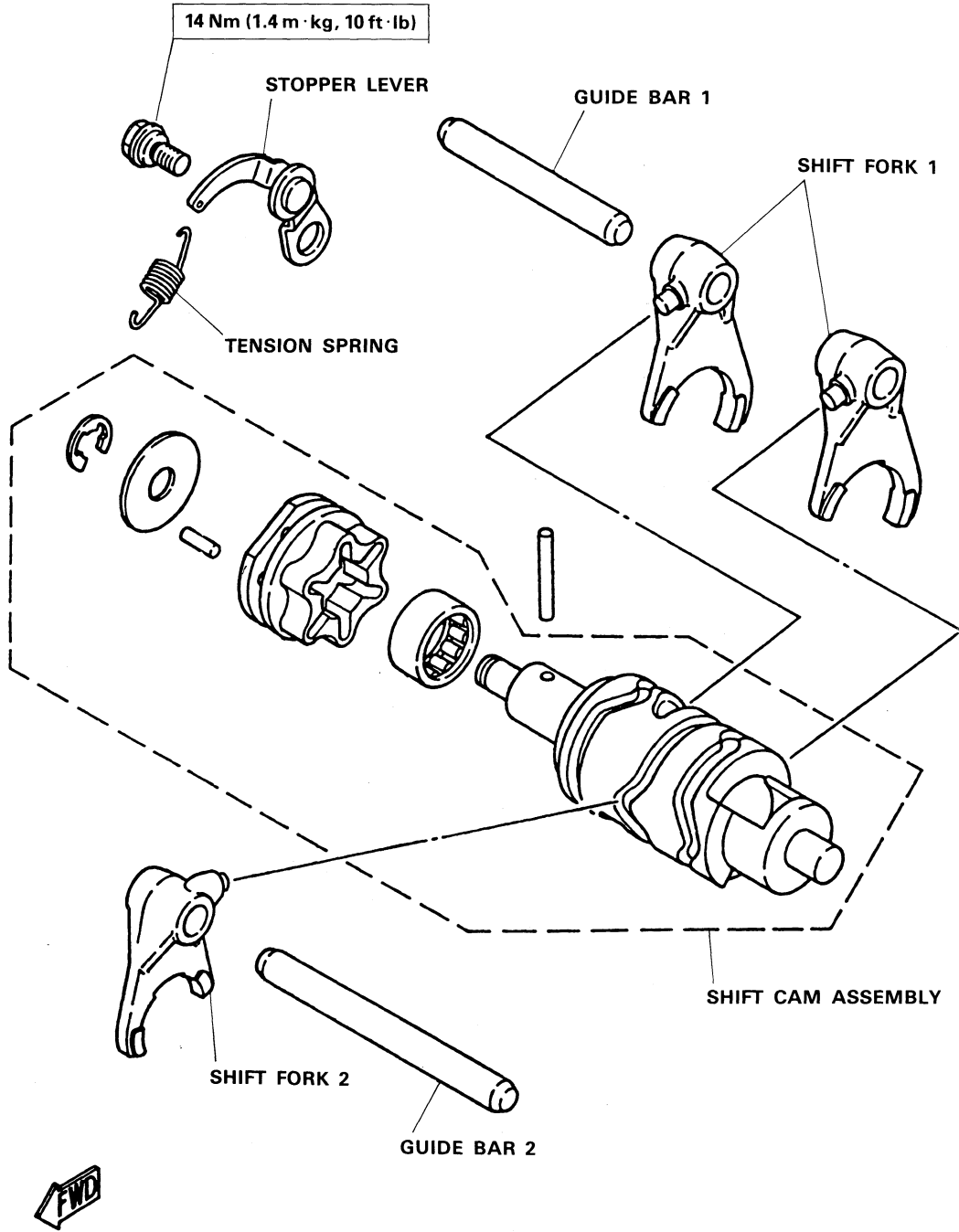

SHIFT SHAFT/PEDAL

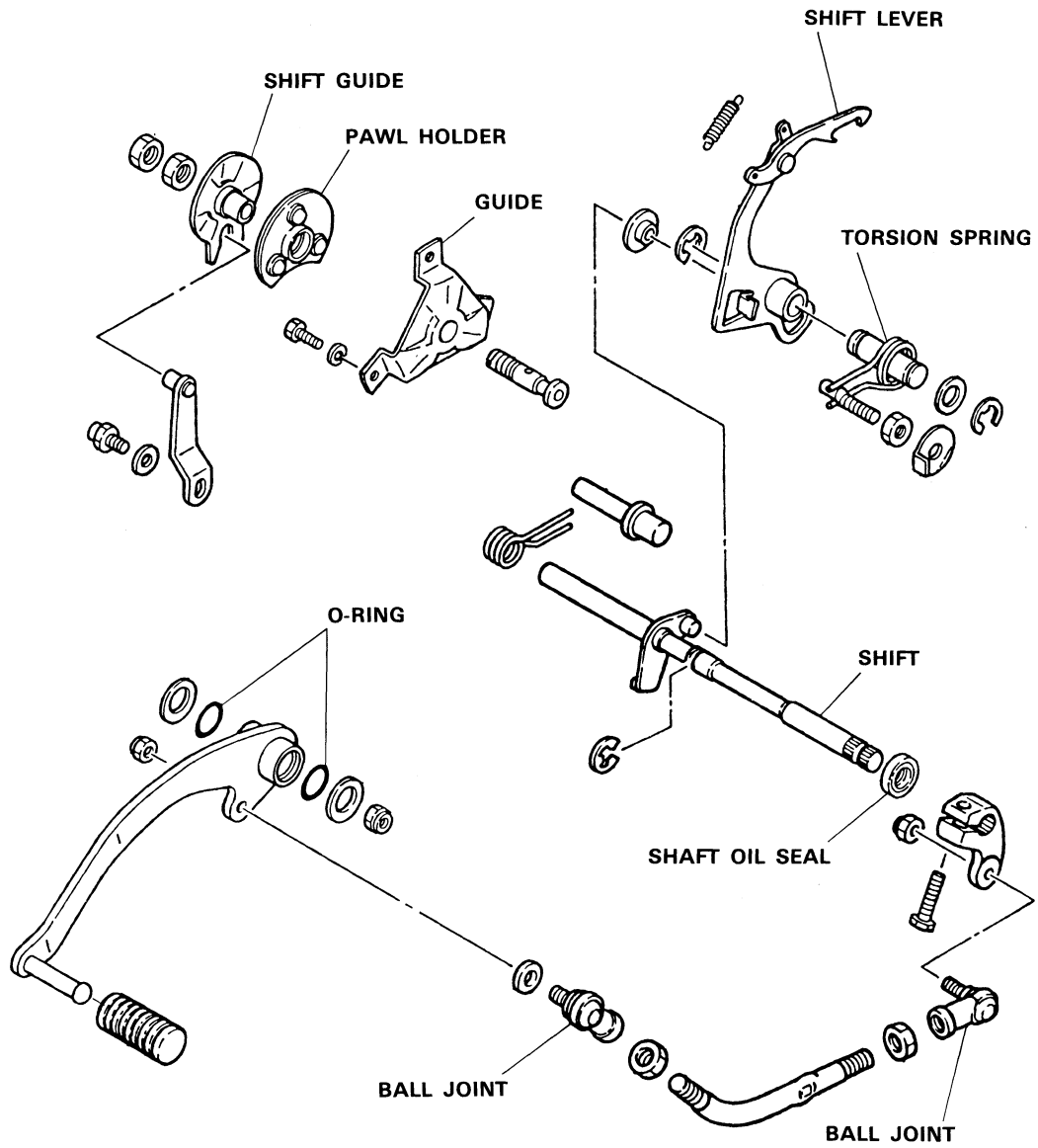

STEERING

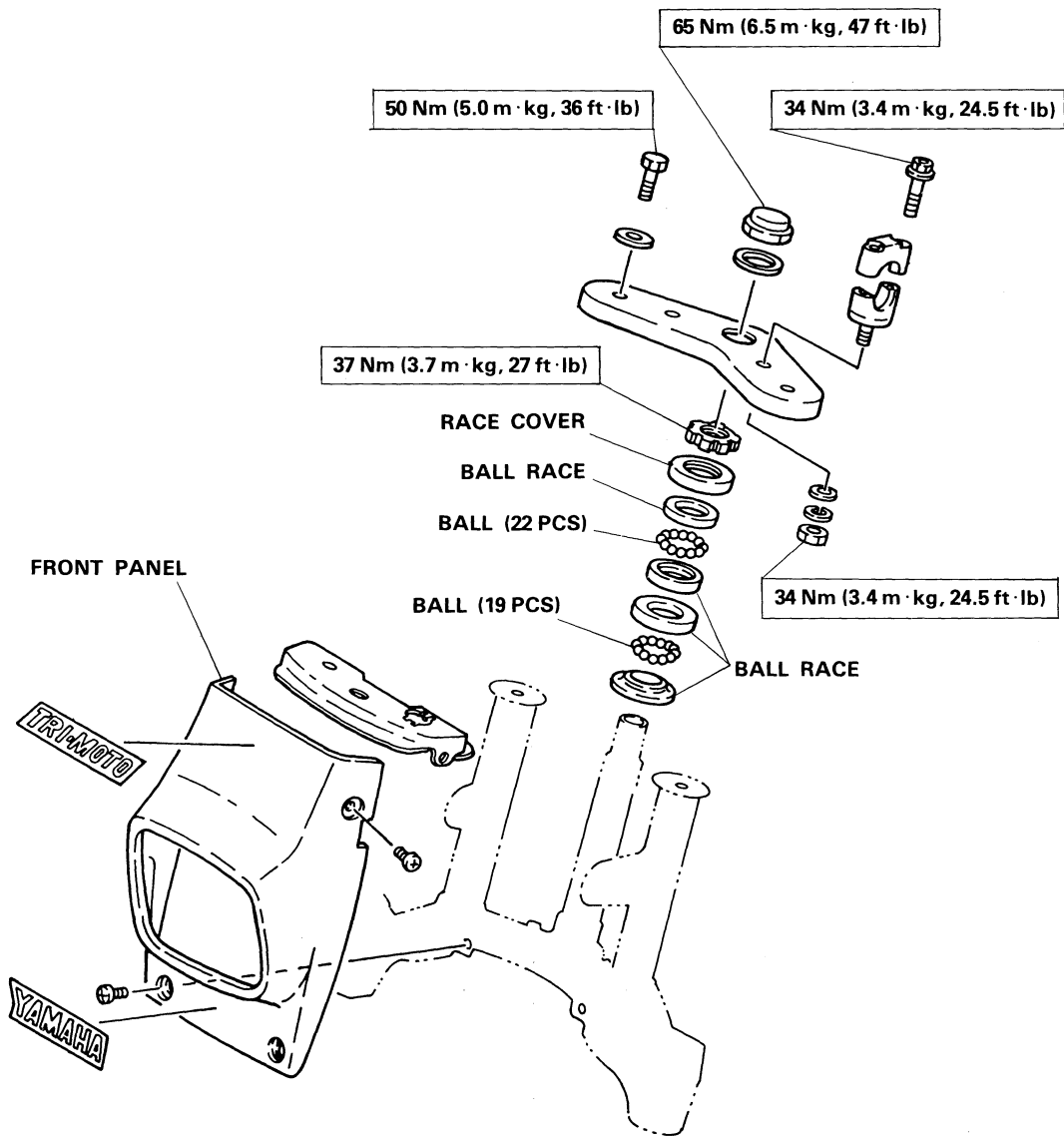

FRONT FORK

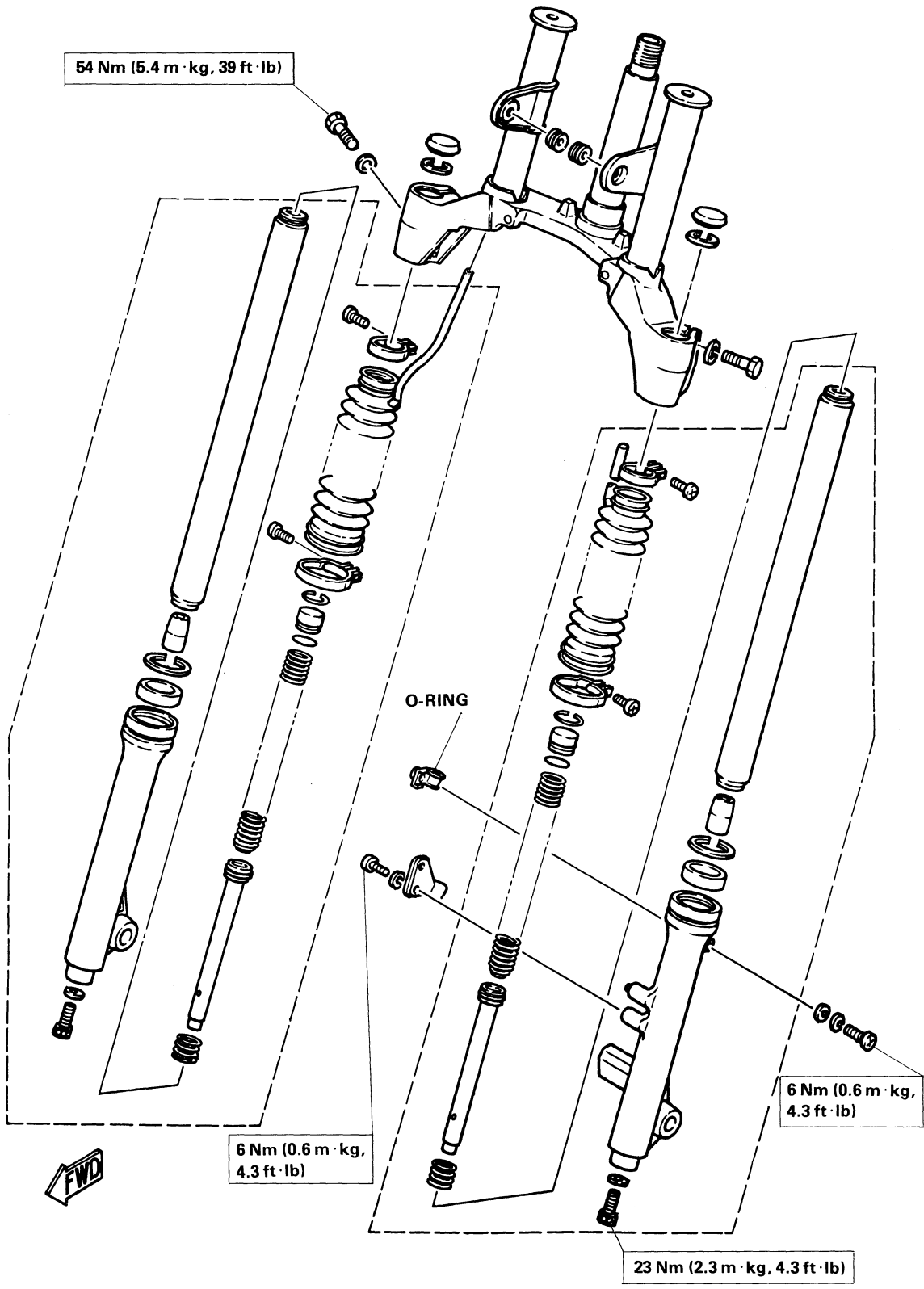

FRONT WHEEL

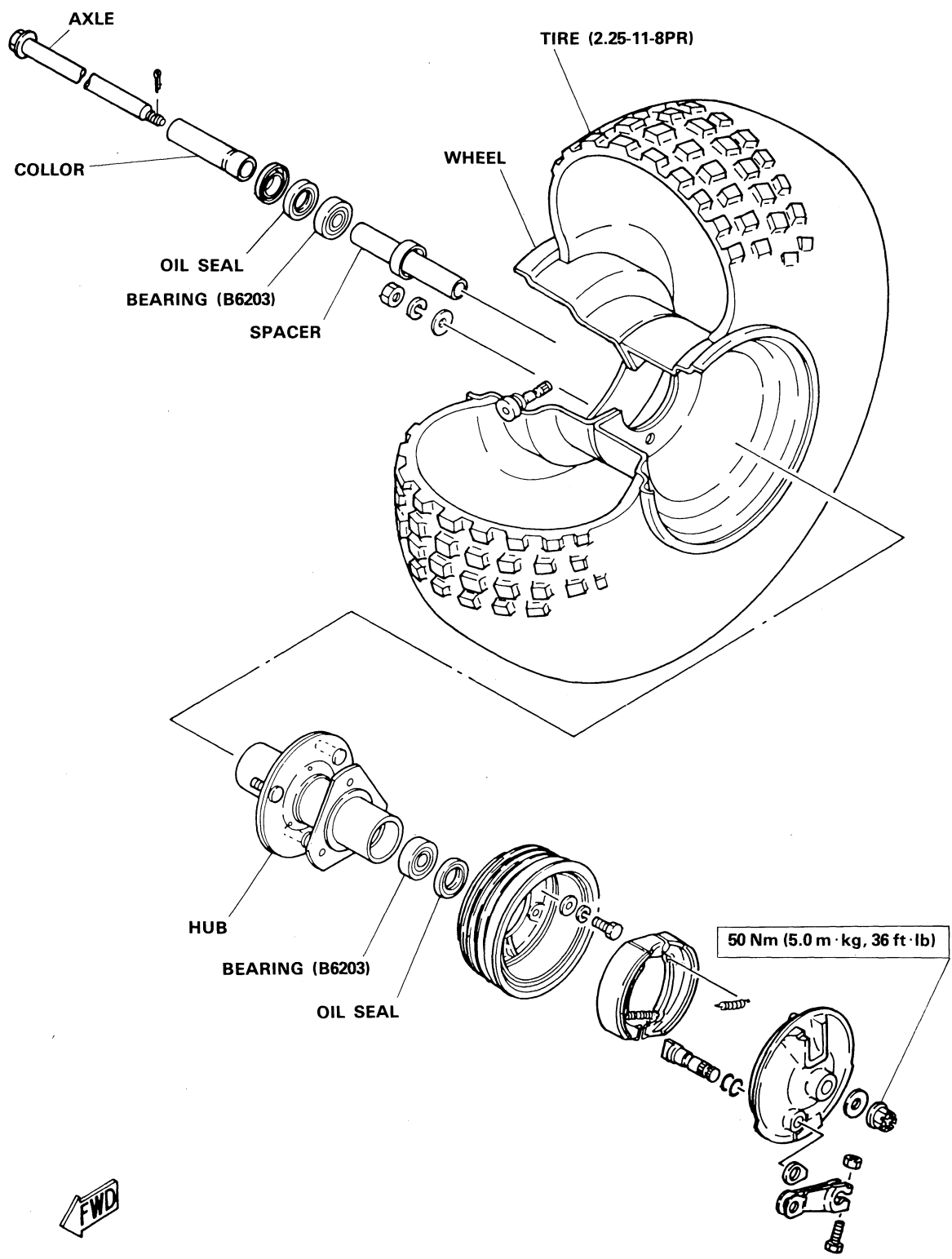

REAR WHEEL

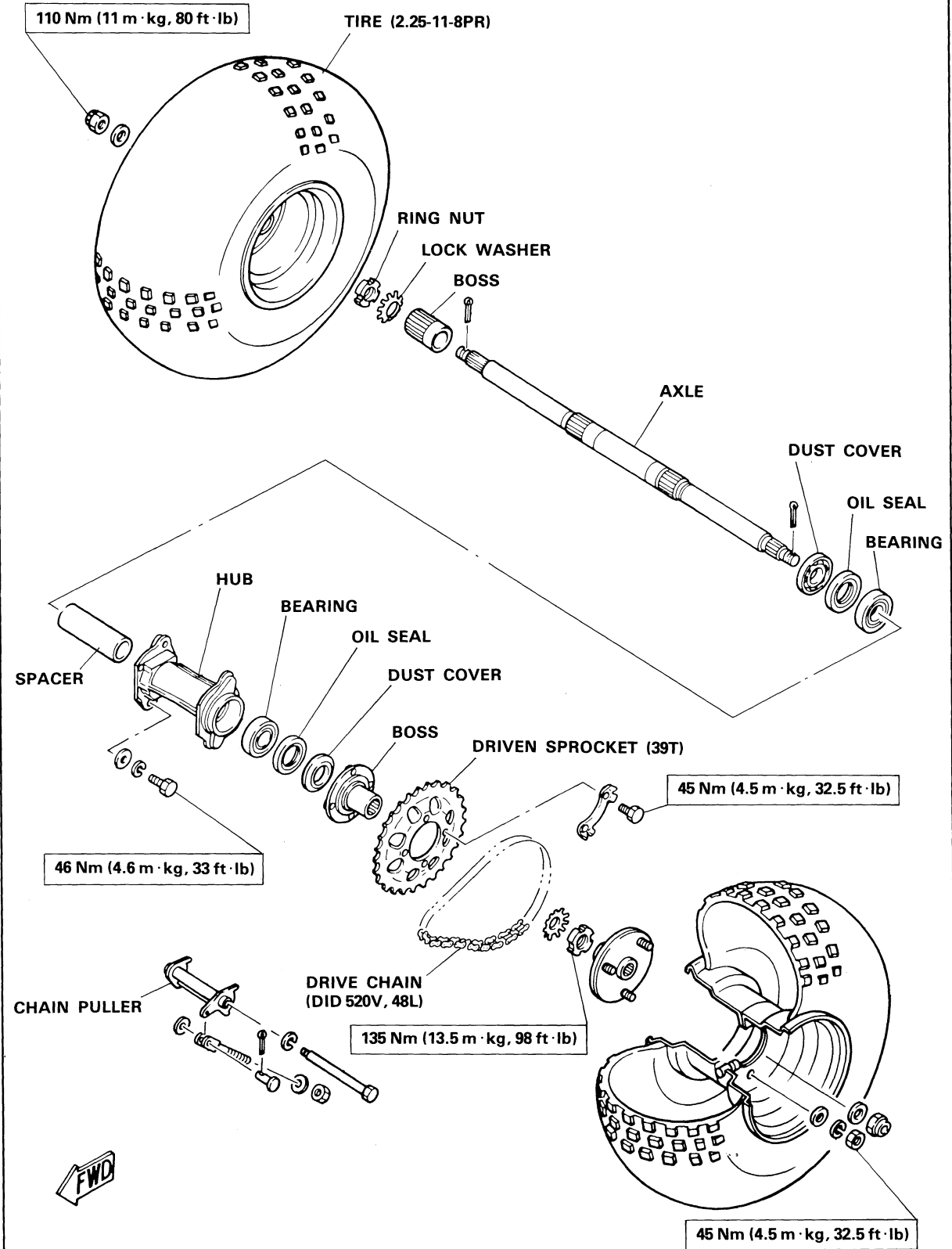

ELECTRICAL

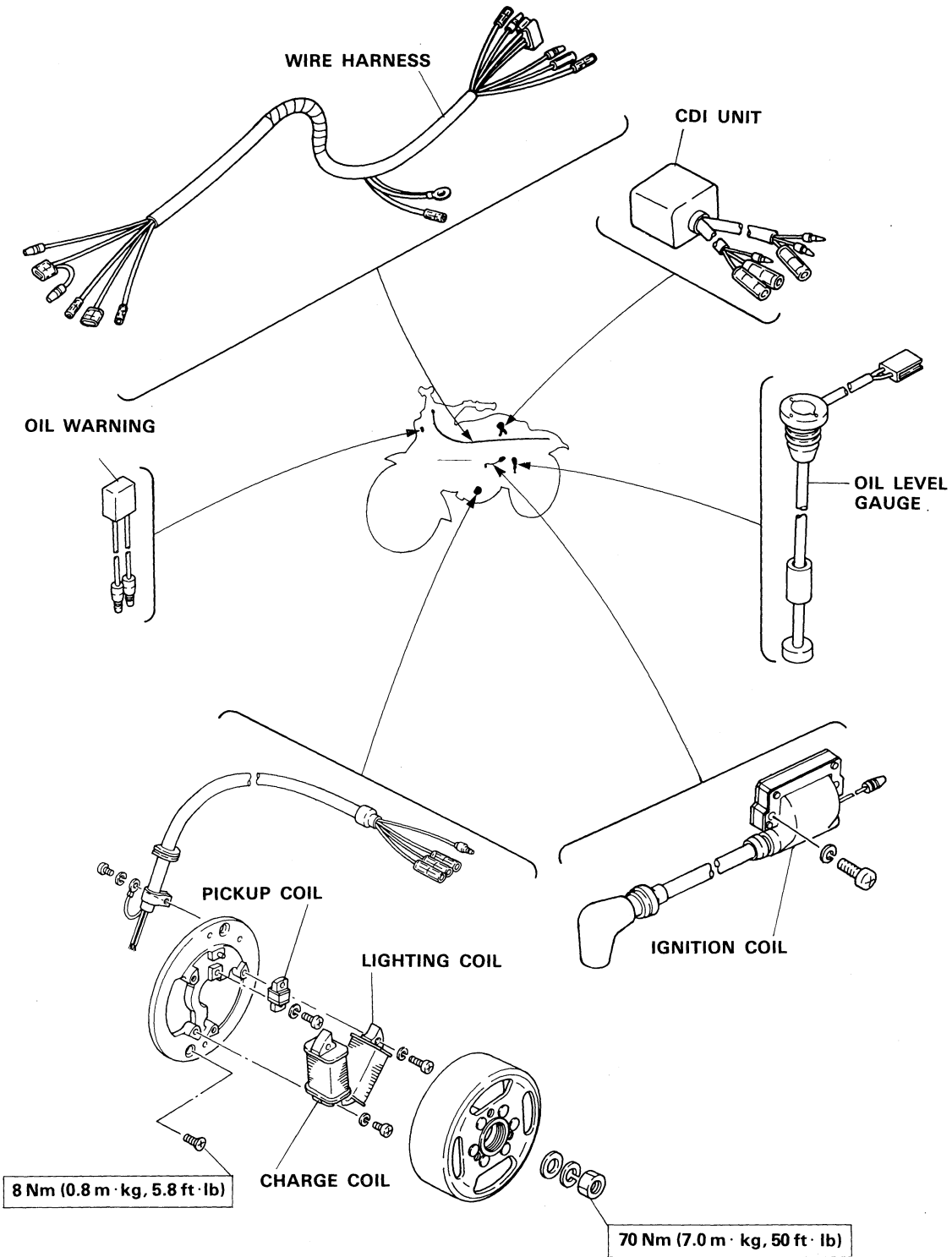

CABLE ROUTING

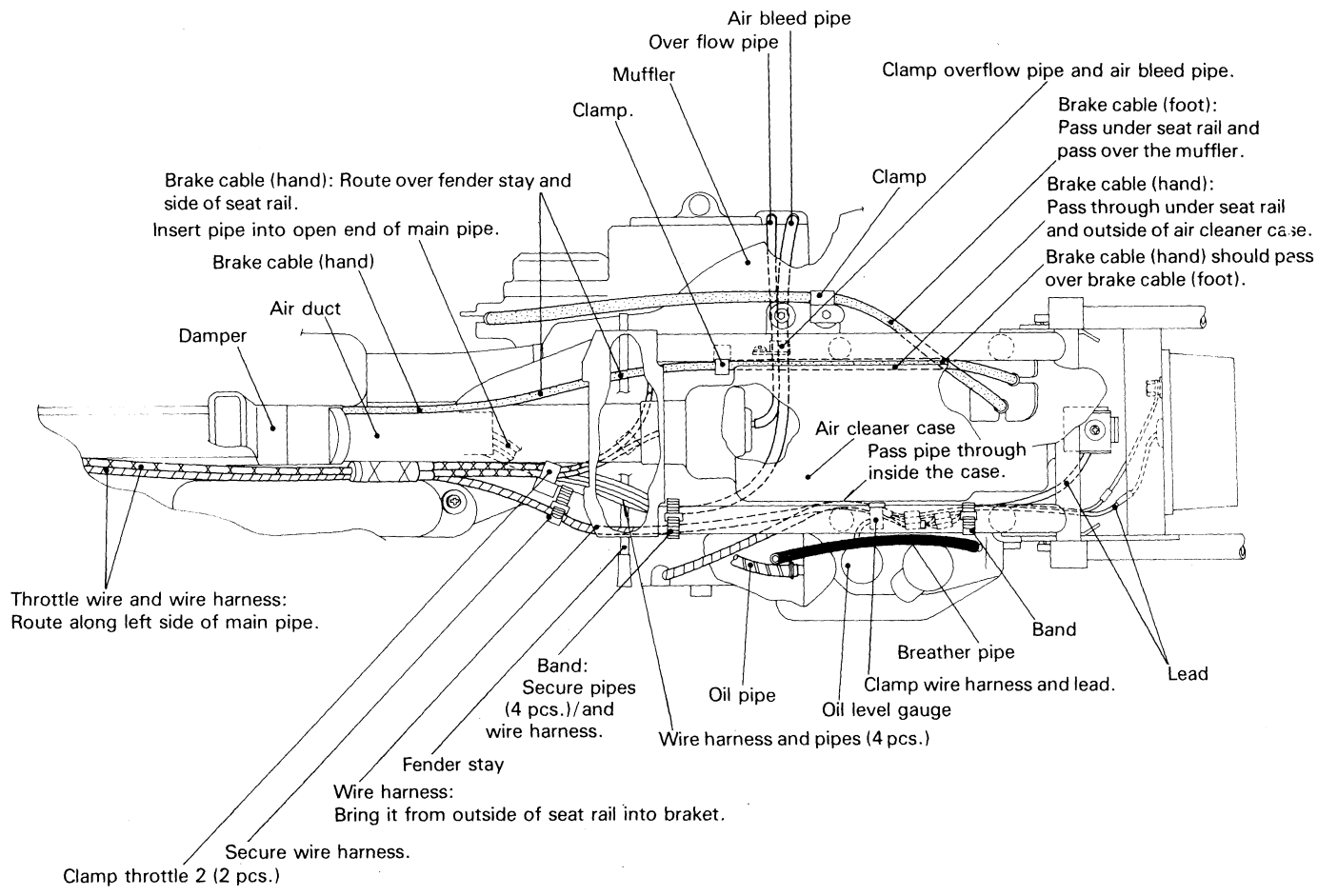
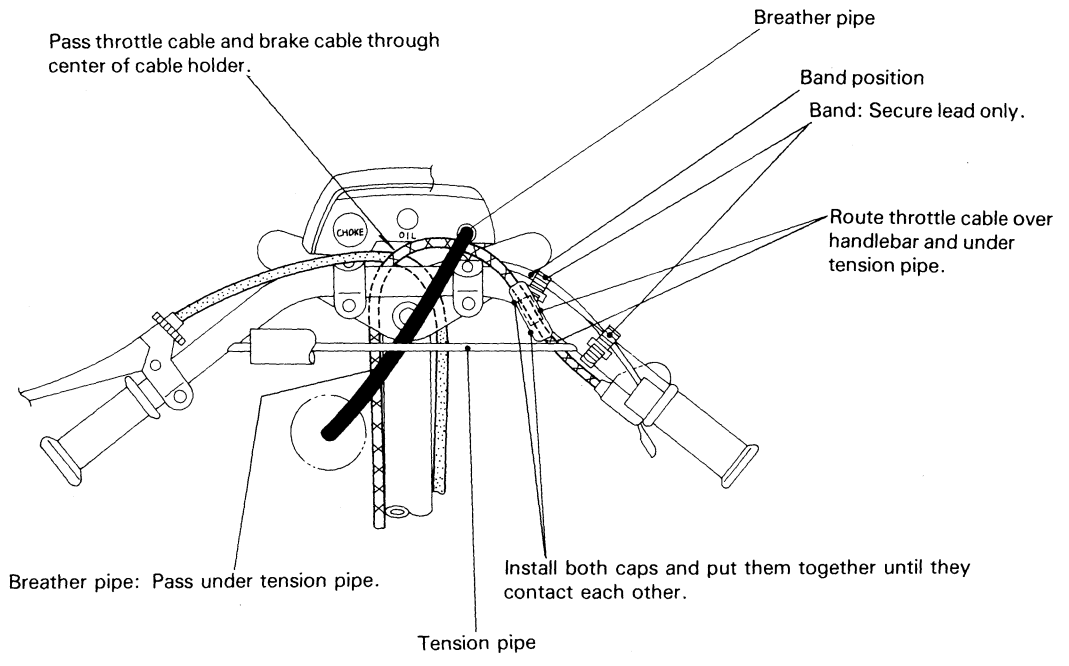

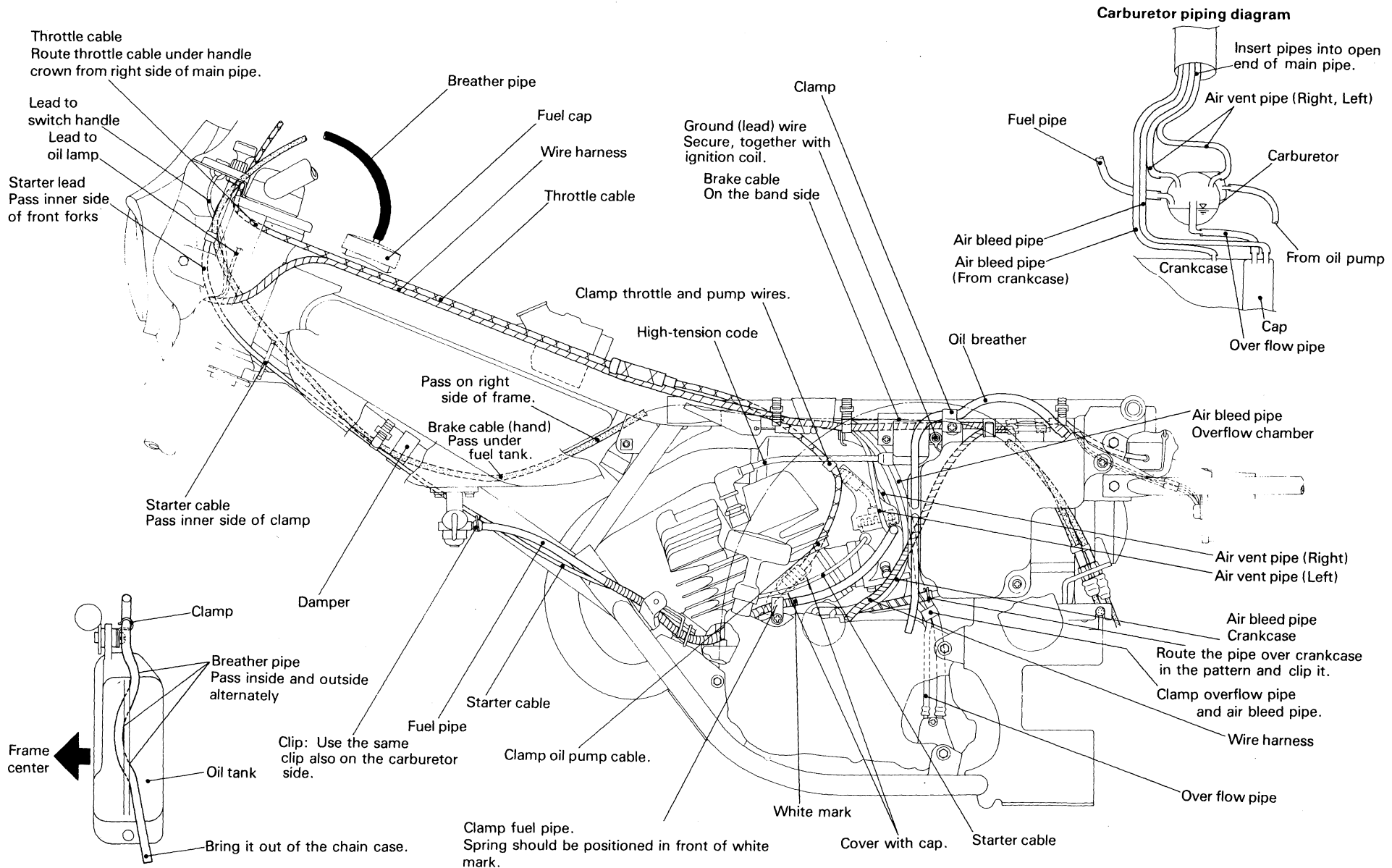

Carburetor piping diagram

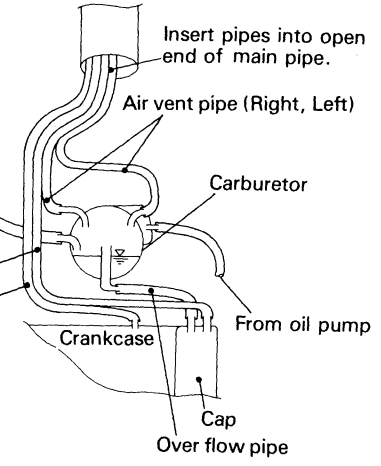

Oil breather pipe routing diagram

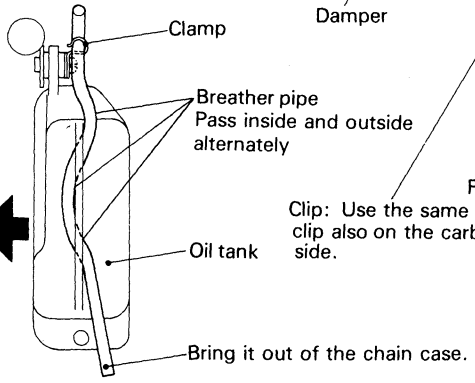

YT175J WIRING DIAGRAM

