



Roughrider

THREE-WHEEL ALL-TERRAIN CYCLES

MODEL 500 5 h.p. - 206cc

MODEL 800 8 h.p. - 319cc

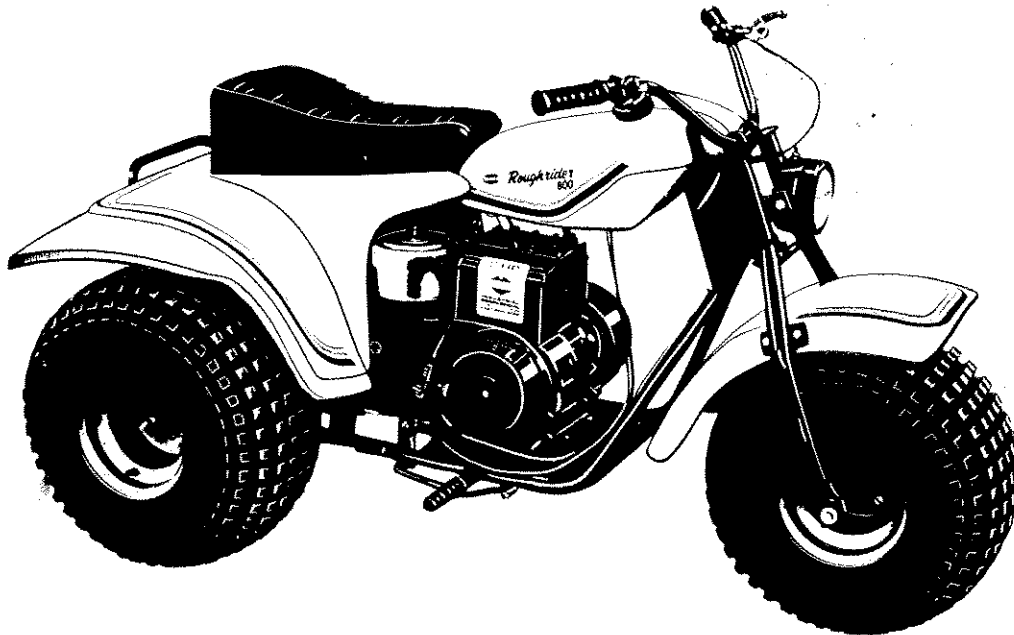

OWNER'S MANUAL

FOR FUTURE REFERENCE WHEN ORDERING PARTS, RECORD THE FOLLOWING DATA FROM YOUR VEHICLE.

_____ MODEL NO.

_____ SERIAL NO. FROM TAG ON MAIN FRAME

_____ ENGINE SERIAL NO. FROM CARBURETOR SIDE OF ENGINE (MODEL 500)
FROM TOP OF ENGINE (MODEL 800)

SPECIAL  PRODUCTS

15000 W. 44TH AVE. GOLDEN, COLO. 80401 • 303-279-5544

TABLE OF CONTENTS

ASSEMBLY INSTRUCTIONS	1,2
PARTS LIST	3
EXPLODED VIEW DRAWING	4
SAFETY	5
OPERATING CONTROLS	6, 7, 8
RIDING AND OPERATING INSTRUCTIONS	8, 9, 10
SERVICE INSTRUCTIONS	10, 11, 12, 13
TORQUE CONVERTER PARTS	12, 13
STORAGE INSTRUCTIONS	14
WARRANTY	14
PARTS ORDERING INFORMATION	15

ASSEMBLY

NOTE: Reference numbers are from exploded view parts drawing on page 4.

The master carton should contain the following:

- 1) One Main Frame and Engine Assembly
- 2) One Rear Fender (79)
- 3) One Front Fender (82)
- 4) Three Wheel and Tire Assemblies (60)
- 5) One Seat (80)
- 6) One Front Fork (54)
- 7) One Handlebar (57)
- 8) One Gas Tank (73) for Model 800 or One Center Cover (76) for Model 500
- 9) One Belt Guard (53)
- 10) One Front Hub (59)
- 11) One Front Axle (63)
- 12) One Rear Handle (68)
- 13) One Hardware Package Containing:

MODEL 500

- a) Two Locking Collars (64)
- b) Two "U" Bolts (58)
- c) Two Small Cable Ties
- d) Two Axle Bushings (62)
- e) Four 5/8 in. Bearings (33)
- f) Two 5/16 in. NC x 3/4 in. Hex Cap Screws (86)
- g) Nine 5/16 in. NC x 1 in. Gr. 5 Hex Cap Screws (10)
- h) One 5/16 in. NC x 3 in. Hex Cap Screw (77)
- i) Fourteen 5/16 in. NC Locknuts (11)
- j) Eight 5/16 in. Flatwashers (7)
- k) Four 5/16 in. NC Hex Nuts (81)
- l) Six 5/16 in. Lockwashers (51)
- m) Twelve 1/2 in. Lug Nuts (61)
- n) One 5/8 in. NC x 9 in. Hex Cap Screw (55)
- o) One 5/8 in. NC Locknut (56)
- p) Two 5/8 in. Machine Washers (34)
- q) One Cover Bushing (78)

MODEL 800

- a) Two Locking Collars (64)
- b) Two "U" Bolts (58)
- c) Two Small Cable Ties
- d) Two Axle Bushings (62)
- e) Four 5/8 in. Bearings (33)
- f) Two 5/16 in. NC x 3/4 in. Hex Cap Screws (86)
- g) Eight 5/16 in. NC x 1 in. Gr. 5 Hex Cap Screws (10)
- h) One 5/16 in. NC x 3-1/2 in. Hex Cap Screw (75)
- i) Thirteen 5/16 in. NC Locknuts (11)
- j) Eight 5/16 in. Flatwashers (7)
- k) Four 5/16 in. NC Hex Nuts (81)
- l) Six 5/16 in. Lockwashers (51)
- m) Two 3/8 in. NC x 3/4 in. Hex Cap Screws (84)
- n) Two 3/8 in. Lockwashers (85)
- o) Twelve 1/2 in. Lug Nuts (61)
- p) One 5/8 in. NC x 9 in. Hex Cap Screw (55)
- q) One 5/8 in. NC Locknut (56)
- r) Two 5/8 in. Machine Washers (34)

- 14) One Bag or Box of Parts Containing:

MODEL 500

- a) Two Hand Grips (66)
- b) One Brake Lever (65)
- c) One Stop Switch (67)

MODEL 800

- a) Two Hand Grips (66)
- b) One Brake Lever (65)
- c) One Stop Switch (67)
- d) One Tank Valve (72)
- e) One Bushing (71)
- f) One Headlight (63)



NOTE: THIS SAFETY ALERT SYMBOL IDENTIFIES IMPORTANT SAFETY MESSAGES IN THIS MANUAL.

ASSEMBLY INSTRUCTIONS

- STEP 1:** Install the rear wheels (60) using the lug nuts (61). The air filler stem should be toward the outside.
- STEP 2:** Support the front of the frame on a block approximately 10 in. off the floor.
- STEP 3:** Insert the bearings (33) into the fork mount of the frame (1), one into the top and one into the bottom.
- STEP 4:** Before mounting the fork (54), insert the throttle lever (43) through the center of the fork assembly. Using fork mount bolt (55) and two spacer washers (34), install the fork (54). One spacer washer goes on top and one on the bottom between the fork mount bearings (33) and the mount surfaces on the fork. Install the locknut (56) on the bottom of the fork mount bolt (55). NOTE: The locknut should be tightened only until the fork mount bolt is free of up and down movement. Overtightening will cause bearing damage.
- STEP 5:** Bolt the wheel (60) to the front hub (59) using lug nuts (61).
- STEP 6:** Insert one axle bearing (33) into each end of the hub (59).
- STEP 7:** Using the axle shaft (63) and the axle spacers (62), install the wheel and hub assembly between the fork (54). One axle spacer (62) should be between the bearing and the fork tube on each end of the hub.
- STEP 8:** Install one locking collar (64) on each end of the axle shaft (63). Tighten the set screws in the locking collars. It may be necessary to squeeze the fork tubes together as you tighten the second locking collar to remove side play in the hub-spindle assembly.
- STEP 9:** Using the "U" bolts (58) and locknuts (11), install the handlebars (57) on the fork (54). While sitting on the cycle, position the handlebars where they are comfortable but do not interfere with the tank when a maximum turn is attempted. Tighten the "U" bolt nuts (11) securely.
- STEP 10:** With the throttle lever toward the front, slide the throttle assembly (43) onto the right handlebar. Push the hand grip (66) all the way onto the right handlebar. Tighten the throttle assembly. Use cable ties to attach cable to the frame.
- STEP 11:** Slide the hand brake assembly (65) onto the left handlebar. The lever should be towards the front and slightly down. Push the hand grip (66) all the way onto the left handlebar. Tighten the brake assembly. Use cable ties to attach cable to the frame.
- STEP 12:** Adjust the hand brake. See brake adjustment on page 11.
- STEP 13:** Install the belt guard (53) using hex cap screws (86), lockwashers (51) and flatwashers (7) in this sequence; 1) Lower rear mount, 2) Lower front mount, 3) Upper front mount bolt and 4) Upper rear mount bolt.
- STEP 14:** Install the front fender (82) using bolts (10), flatwashers (7) and locknuts (11). Place the washers between the nut and fender. Tighten securely.
- STEP 15:** Position the rear fender (79) on the frame (1), aligning the four holes in the fender with the corresponding holes in the frame. Install the seat (80) and secure in place with lockwashers (51) and nuts (81).
- STEP 16:** (Model 800) Install the rubber bushing (71) into the tank (73) and then insert valve (72) into the bushing. Apply liquid soap to the bushing and valve to reduce friction when installing. Attach the tank (73) to the main frame (1) using bolt (75), flatwasher (7) and locknut (11). Then insert the gas line from the engine (39) onto the valve (72). Be certain to attach the clamp to the end of the gas line.

(Model 500) Attach the center cover (76) to the main frame (1) using bolt (77), flatwashers (7), bushing (78) and locknut (11).



CAUTION

STEP 17:

Check the tire pressure to assure 4-5 lbs. of pressure. Riding on under-inflated tires may cause tire damage. Riding on overinflated tires will cause a rough, bumpy ride. Variations of tire pressure among the three tires may increase the difficulty of turns or cause a tendency to pull to one side or another.

NOTE: Tires should be inflated with a manual tire pump rather than high-pressure systems found in most service stations. New tires may lose air until tire bead seals on the rim.

STEP 18: Peel back the top paper layer covering the decals on the rear fender (70), front fender (82) and the tank (73) or the center cover (76). If the top layer does not easily separate from the decal apply pressure with a straight edge and try again.

SEE ENGINE MANUFACTURER'S MANUAL FOR ENGINE LUBRICATING INSTRUCTIONS AND GASOLINE SERVICING BEFORE TRYING TO START THE ENGINE.

REFERENCE NUMBER	PART NUMBER	DESCRIPTION	NUMBER REQUIRED	
			Model 500	Model 800
	TW420101	Model 500 Roughrider complete		
	TW420102	Model 800 Roughrider complete		
1	TW420125A	Main frame	1	1
2	TW420128	Jack Shaft Bracket	1	1
3	TW420174	Idler Arm	1	1
4	MB17529	3/8 in. NC x 1 in. Gr. 5 Hex Cap Screw	1	1
5	LN17215	3/8 in. NC Locknut	2	2
6	MB1759	3/8 in. NC x 2 in. Gr. 5 Hex Cap Screw	1	1
7	FW1748	5/16 in. Flatwasher	13	12
8	TW420149	Bushing	1	1
9	TW420143	Idler Gear	1	1
10	MB17526	5/16 in. NC x 1 in. Gr. 5 Hex Cap Screw	16	16
11	LN1727	5/16 in. NC Locknut	27	27
12	TW420154	Rear Axle	1	1
13	BE22148	1 in. Locking Collar	2	2
14	BE22147	Flange	4	4
15	BE22146	Bearing	2	2
16	TW420155	Rear Hub	2	2
17	LB171210	1/2 in. NF Lug Bolt	12	12
18	MB17528	5/16 in. NC x 2 in. Gr. 5 Hex Cap Screw	2	2
19	SS17620	3/8 in. NC x 2 1/2 in. Square Head Set Screw	1	1
20	TW420116	Chain With Connecting Link	1	1
21	TW420117	Connecting Link	—	—
22	TW420131	Brake Band	1	1
23	TW420145	Rear Brake Cable	1	1
24	TW420180	3/8 in. Diam. Brake Pin	1	1
25	TW420148	Cable Clip	2	2
26	TW420181	1/4 in. Diam. Brake Pin	1	1
27	CP171112	5/64 in. x 3/4 in. Cotter Pin	4	4
28	TW420146	Front Brake Cable	1	1
29	MB17531	1/4 in. NC x 1 in. Gr. 5 Hex Cap Screw	1	1
30	LN17216	1/4 in. NC Locknut	1	1
31	TW420158	Model 500 Jack Shaft	1	—
31	TW420159	Model 800 Jack Shaft	—	1
32	TW420173	Jack Shaft Tube	1	1
33	BE22151	5/8 in. Bearing Assembly w/Snap Ring	6	6
34	FW17420	5/8 in. Machine Washer	4	4
35	TW420178	3/16 in. Key	2	2
36	TW420142	Drive Gear	1	1
37	TW420133	Model 500 Driven Pulley	1	—
37A	TW420132A	Cup Washer	1	—
37	TW420136	Model 800 Driven Pulley	—	1
38	LN17218	5/8 in. NF Thin Locknut	2	2
39	HC390505	5 h.p. Engine (Model 500)	1	—
39	HC390508	8 h.p. Engine (Model 800)	—	1
40	TW420120	Throttle Clip	—	—
41	TW420187	Spring	—	—
42	MB17824	#10 NF x 5/8 in. Clip Screw	—	—
43	TW420112	Throttle Cable	1	1
44	TW420179	Ground Wire w/Connectors	1	1
45	MB17530	5/16 in. NC x 1-3/4 in. Gr. 5 Hex Cap Screw	4	4
46	TW420177	Bushing (Model 500 only)	1	—
47	TW420132	Model 500 Driver Pulley	1	—
47	TW420135	Model 800 Driver Pulley	—	1
47A	FW17422	5/16 in. Flatwasher (Special) (Model 500)	1	—
47B	FW17421	7/16 in. Flatwasher (Special) (Model 800)	—	1
48	MB17533	5/16 in. NF x 1-3/4 in. Hex Cap Screw (Model 500)	1	—
48	MB17532	7/16 in. NF x 2 in. Hex Cap Screw (Model 800)	—	1
49	TW420157	Belt Cover Bracket	1	1
50	MB17796	5/16 in. NF x 3/4 in. Hex Cap Screw	2	2
51	LW1739	5/16 in. Lockwasher	9	9
52	TW420134	3/4 in. Wide Belt (Model 500)	1	—
52	TW420137	7/8 in. Wide Belt (Model 800)	—	1
53	TW420147	Belt Cover	1	1
54	TW420126	Fork	1	1
55	MB17797	5/8 in. NC x 9 in. Hex Cap Screw	1	1
56	LN17212	5/8 in. NC Locknut	1	1
57	TW420182	Handlebar	1	1
58	TW420119	"U" Bolt	2	2
59	TW420129A	Front Hub	1	1
60	TW420110	Tire and Wheel	3	3
61	HN171211	1/2 in. Lug Nut	12	12
62	TW420176	Axle Bushing	2	2
63	TW420175	Front Axle	1	1
64	TW420115	Locking Collar	2	2
65	TW420113	Brake Lever Assembly	1	1
65A	TW420113A	Brake Lever Screw	—	—
65B	TW420113B	Brake Lever Lock	—	—
66	TW420111	Handle Grip	2	2
67	TW420153	Stop Switch	1	1
68	TW420156	Rear Handle	1	1
69	TW420186	Foam Pad (Model 800)	—	2
70	TW420150	Large Cable Ties (Model 800)	—	2
71	TW420123	Valve Bushing (Model 800)	—	1
72	TW420122	Gas Valve (Model 800)	—	1
73	TW420121	Gas Tank (Model 800 only)	—	1
74	TW420124	Gas Cap (Model 800 only)	—	1
75	MB17792	5/16 in. NC x 3-1/2 in. Hex Cap Screw (Model 800)	—	1
76	TW420141	Center Cover (Model 500 only)	1	—
77	MB17729	5/16 in. NC x 3 in. Hex Cap Screw (Model 500)	1	—
78	TW420183	Spacer (Model 500)	1	—
79	TW420139	Rear Fender	1	1
80	TW420152	Seat	1	1
81	HN17117	5/16 in. NC Hex Nut	4	4
82	TW420140	Front Fender	1	1
83	TW420144	Headlight (Model 800 only)	—	1
84	MB17769	3/8 in. NC x 3/4 in. Hex Cap Screw (Model 800)	—	2
85	LW1731	3/8 in. Lockwasher (Model 800)	—	2
86	MB17798	5/16 in. NC x 3/4 in. Hex Cap Screw	2	2
87	LW1732	7/16 in. Lockwasher	1	1
	TW420151	Short Tie	5	5
	TW420127	Hardware Package for Model 500	1	—
	TW420184	Hardware Package for Model 800	—	1

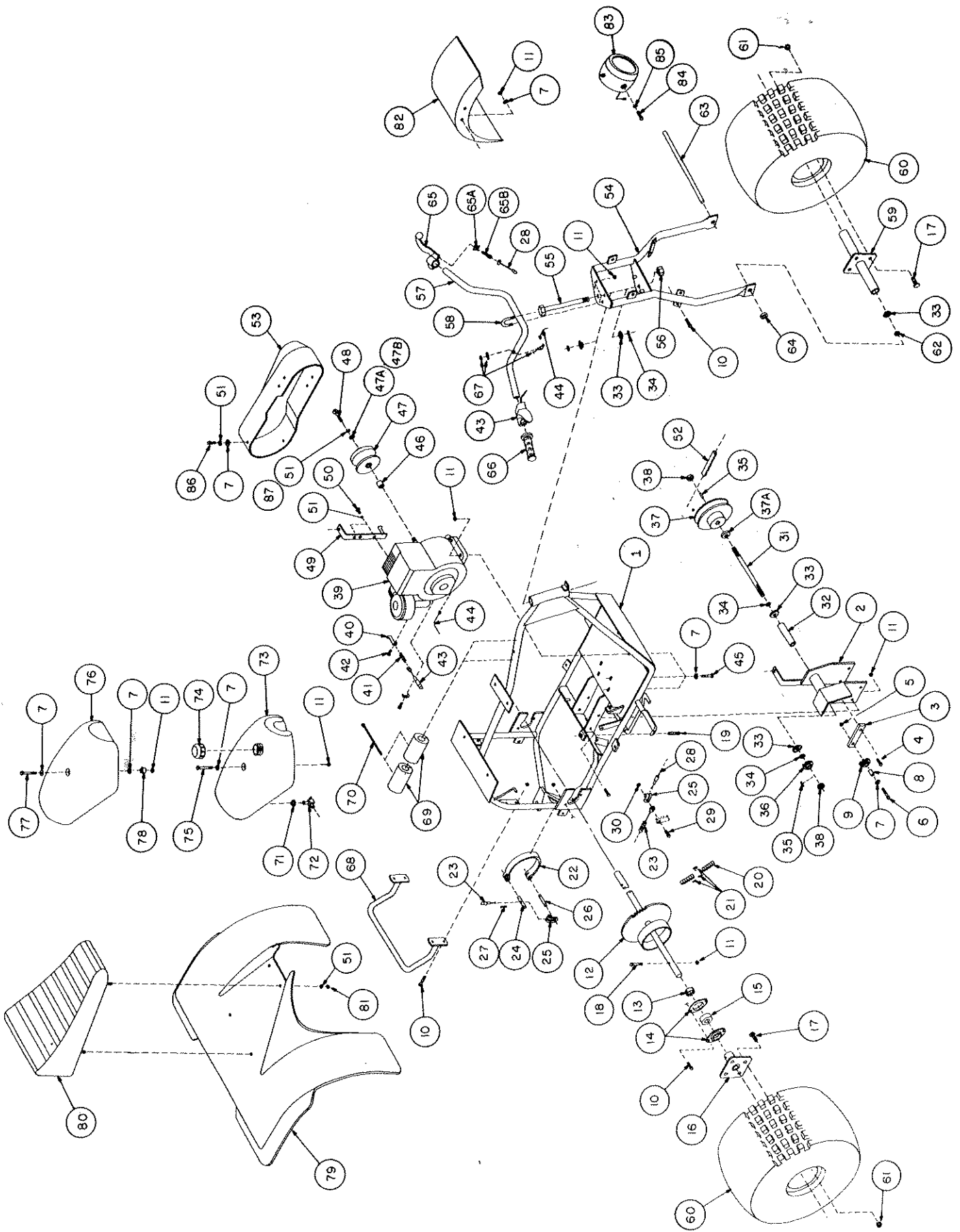



SAFETY

Do not start or run the three-wheeler before reading the complete owner's manual to familiarize yourself with assembly, service and operation. Failure to read and follow these instructions could result in serious damage to the vehicle or personal injury.

- 1) This vehicle is not licensable. It is a violation of the law to operate it on public streets, roads and walkways.
- 2) All operators should be familiar with the vehicle and the owner's manual before operation.
- 3) All operators should be of sufficient age and physical ability to operate the vehicle.
- 4) Always wear approved protective equipment including a safety helmet, eye protection, gloves, boots and protective clothing.
- 5) Operate only on terrain within your riding abilities.
- 6) Before starting or operating check for loose nuts, bolts and make the necessary maintenance adjustments.
- 7) Before starting the vehicle, set the parking brake. Check to assure the throttle is in the idle position. The operator should be seated in the operating position.
- 8) Operators should keep all parts of their body and their clothing away from moving parts.
- 9) This vehicle is intended for single operator use only. Do not carry passengers.
- 10) This vehicle is not designed for racing, competitive sports or stunt riding.
- 11) Do not operate the engine indoors. Exhaust fumes contain carbon monoxide which is a tasteless, odorless, poisonous gas.
- 12) Do not adjust or repair the vehicle with the engine running or while in motion.
- 13) Do not attempt to fill the gasoline tank when the engine is running or hot. All spilled gasoline should be cleaned up before attempting to start the engine.
- 14) Always turn off the engine before dismounting the vehicle.
- 15) Always keep feet on foot pegs while operating the vehicle.
- 16) Always replace missing or defaced decals.



SAFETY DECALS

ALWAYS REPLACE MISSING OR DEFACED DECALS.

PART NUMBER: DL51-1-39
LOCATION: TOP OF GAS TANK OR CENTER COVER
BELOW BOLT HOLE



OPERATING CONTROLS



CAUTION: DO NOT START OR OPERATE THE VEHICLE UNTIL YOU HAVE READ THE OWNER'S MANUAL ON THE CYCLE AND THE ENGINE AND ARE THOROUGHLY FAMILIAR WITH ALL THE CONTROLS. READ THE INSTRUCTIONS FOR THROTTLE CONTROL, BRAKE, ETC.

THROTTLE CONTROL

The throttle is operated by the finger lever on the right handlebar. Pulling the lever increases the engine speed. As engine speed increases, the centrifugal clutch automatically engages moving the vehicle forward. Vehicle speed increases as engine speed increases. To disengage the centrifugal clutch, release the throttle lever allowing the engine to return to idle.

Before starting the engine be certain that the throttle returns freely to the idle position.

BRAKE OPERATION

The brake is operated by either the handle lever on the left handlebar or by the foot lever on the right foot peg. The two levers may be used separately or together.



CAUTION: BEFORE OPERATING THE VEHICLE TEST THE HAND BRAKE AND FOOT BRAKE.

HAND BRAKE TEST: SET THE PARKING BRAKE ON THE HAND LEVER BY PULLING THE LEVER BACK AND LOCKING IT IN POSITION WITH THE LOCK RING. START THE ENGINE AND INCREASE ENGINE RPM GRADUALLY TO ASSURE BRAKE WILL HOLD VEHICLE. IF BRAKE WILL NOT HOLD, READJUST THE CABLE. SEE BRAKE ADJUSTMENT ON PAGE 11.

FOOT BRAKE TEST: SIT ON THE VEHICLE AND RELEASE THE PARKING BRAKE. REPEAT THE ABOVE TEST WHILE USING THE FOOT BRAKE. IF THE BRAKE DOES NOT HOLD, SEE BRAKE ADJUSTMENT ON PAGE 11.

THE BRAKE WILL REQUIRE A SHORT BREAK-IN PERIOD BEFORE IT WILL FUNCTION AT PEAK EFFECTIVENESS.

DO NOT OPERATE THE VEHICLE UNLESS BOTH THE FOOT BRAKE AND THE HAND BRAKE ARE FUNCTIONING PROPERLY.

ENGINE STOP LEVER



CAUTION: DO NOT OPERATE THE VEHICLE UNTIL YOU ARE FAMILIAR WITH THE LOCATION AND OPERATION OF THE ENGINE STOP LEVER.

Location: Stop lever is located on the top right side of the handlebar.

Operation: To stop engine press the lever to the "OFF" position.

Also see Engine Manual.

CHOKE CONTROL

Model 500 (5 h.p.) — The choke control is located to the rear of the carburetor. Pull to choke. Push in to cancel.

Model 800 (8 h.p.) — The choke control is located on the lower rear side of the air breather tube. Lower lever to choke and raise lever to cancel.

Also see Engine Manual.

OPERATING CONTROLS REFERENCE PHOTOS

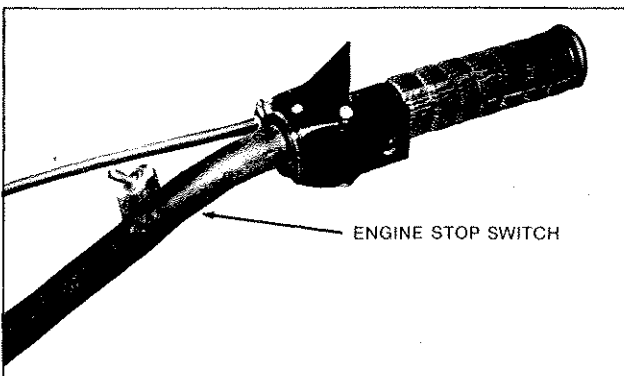
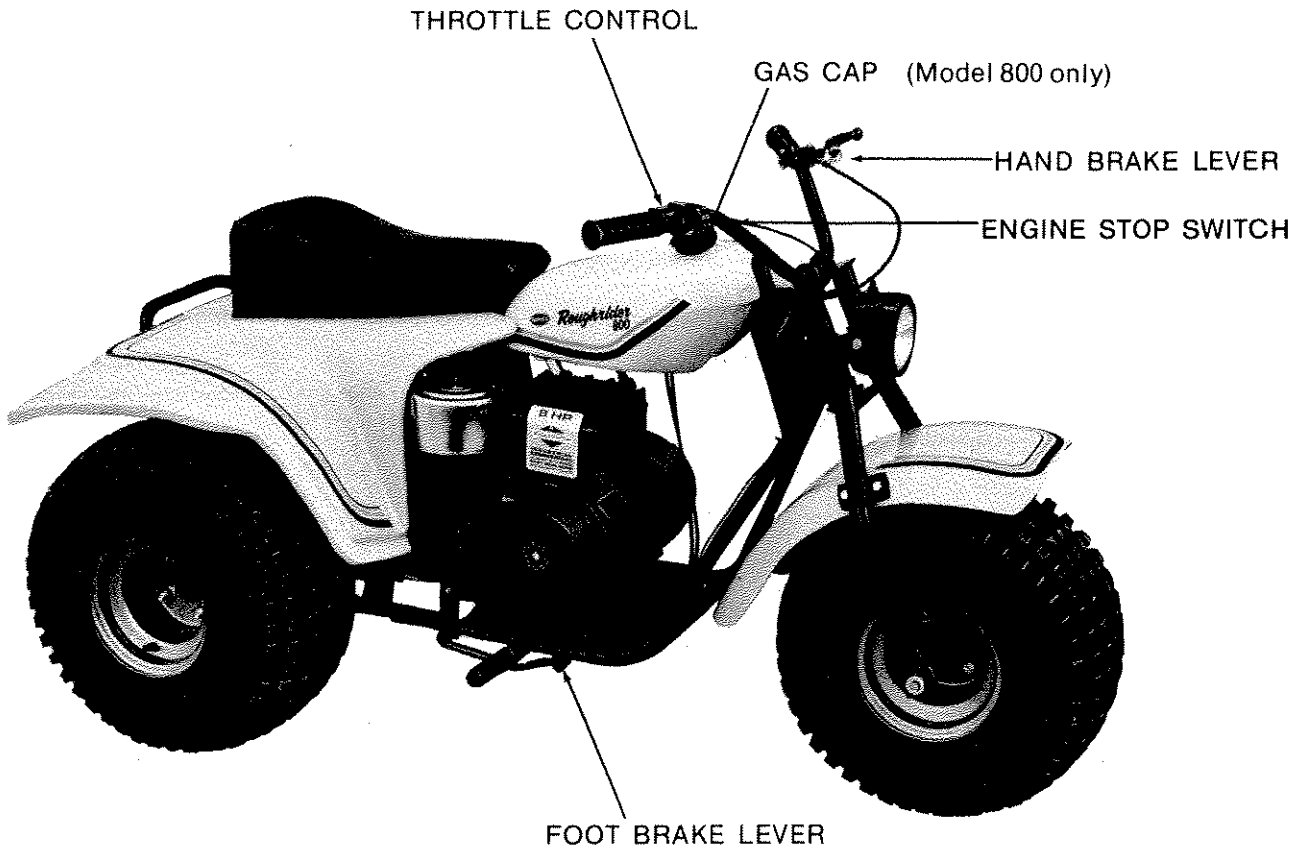

THROTTLE CONTROL

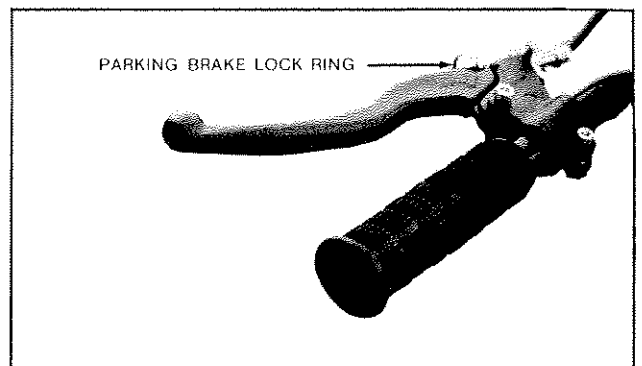

HAND BRAKE LEVER

ENGINE STARTING

- 1) Rider should be seated on the vehicle with the parking brake set.
- 2) Move choke to "ON" position. See engine manual. A warm engine may start without using the choke.
- 3) Assure that the throttle is in the idle position.
- 4) Push the engine stop lever to the "ON" position.
- 5) Pull sharply on the recoil starter rope. Do not allow the rope to snap back.
- 6) After the engine warms up, move the choke to the "OFF" position.

NOTE: Consult the engine manufacturer's manual and operating instructions for additional information concerning engine starting and operation.

RIDING GEAR AND CLOTHING



WARNING: *RIDING WITHOUT PROPER PROTECTIVE CLOTHING IS DANGEROUS.*

- 1) Wear an approved safety helmet.
- 2) Wear eye protection, goggles or safety glasses.
- 3) Wear heavy shoes or boots. Never ride barefoot or with sandals.
- 4) Wear a long sleeve shirt and long pants.
- 5) Wear gloves.



RIDING AND OPERATING INSTRUCTIONS

CAUTION: *BEFORE RIDING IN ANY AREA SURVEY IT FOR HIDDEN HAZARDS, HOLES, AND OBSTACLES. INSPECT THE TERRAIN BEYOND HILLS TO ASSURE SAFE OPERATION.*

NOTE: Attempting to instruct a person in the fundamentals of riding this vehicle by the use of written directions is nearly impossible. This should be considered basic guidance of what to expect.

- 1) Keep your feet on the pegs at all times. If you attempt to place your foot down it can easily come in contact with the rear wheel and cause personal injury.
- 2) Turning

Your initial attempts should be made in an open area free of obstacles and hazards. Choose a dirt or grassy area. Steering on pavement is difficult and requires practice.

Steering the front wheel is not sufficient to accomplish a tight turn. You must assist the vehicle around turns by positioning your body for weight transfer.

Start out by riding in a straight line with large, gradual turns. Start your turn by steering in the direction of the turn. Lean your body to the inside of the turn while supporting your weight on the outside peg. Since the rear axle is solid, it provides equal rotation to both rear wheels at all times. When negotiating a turn, the objective is to reduce the traction on the inside rear wheel, allowing it to slip.

Incorrect turning methods may cause the front wheel to skid sideways with no change in direction. Should this occur, stop or slow down and try again. With practice you will gain enough experience to turn in a very small area.

3) Climbing Hills



CAUTION: *IMPROPER HILL CLIMBING TECHNIQUES MAY CAUSE THE VEHICLE TO TURN OVER BACKWARDS CAUSING DAMAGE OR INJURY.*

Initial attempts to climb hills or slopes should be done on very gradual slopes. As your ability improves, you may progress within the limits of the vehicle and your ability and experience.

Keep your feet on the foot pegs. Lean forward with your body weight raised off the seat. The steeper the hill the more necessary it is to have your body weight forward to keep the front wheel on the ground. Remember to keep your feet on the pegs and to use your body positioning to maintain control.

The steepness and length of the hill will determine the amount of speed or running start necessary to reach the top. As with any vehicle there are limits to the size and length of hill this vehicle will climb. Experience will provide the ability to judge what can and cannot be climbed.

If you cannot complete a climb on a hill or steep incline, dismount while holding the hand brake and then slowly release the brake lever while guiding the vehicle to the bottom of the incline. Do not attempt to turn on a steep incline as this may cause the vehicle to overturn sideways.



WARNING: *DO NOT APPLY THE THROTTLE SUDDENLY WHEN CLIMBING STEEP INCLINES AS THIS SURGE IN POWER MAY LIFT THE FRONT WHEEL AND CAUSE THE VEHICLE TO OVERTURN BACKWARDS.*

4) Descending Hills



CAUTION: *ALWAYS STOP AND OBSERVE THE TERRAIN BELOW BEFORE DESCENDING A HILL.*

Keep your feet on the pegs. Steer directly down the hill whenever possible. With both hands on the handlebars, lean back. Descend with the throttle closed, braking as you go. Keep in mind that hard braking on loose surfaces will cause the vehicle to slide. Sliding wheels may reduce your directional control.

5) Riding in Water

When crossing water pick a place with gradual slopes on both banks. Avoid fast-moving water or water over eight (8 in.) deep. If water is deep enough to contact the spark plug or breather, the engine will stall. Water will reduce the effectiveness of the torque converter drive belt causing slippage. If the belt becomes wet, idle the engine until it dries. Brake bands will also be less effective when wet. Apply brakes several times to heat and dry the drum and band.

6) If the vehicle stops with the engine still running when towing or climbing steep inclines, release the throttle lever as continuous engine torque will cause the belt to overheat and cause damage to the belt.

PRE-RIDE INSPECTION



CAUTION: COMPLETE THIS PRE-RIDE INSPECTION EACH DAY BEFORE STARTING THE ENGINE. FAILURE TO COMPLETE THIS INSPECTION COULD RESULT IN SERIOUS DAMAGE TO THE VEHICLE AND/OR PERSONAL INJURY.

- 1) Check the engine oil level per engine manual instructions.
- 2) Check the fuel level and fill as needed as explained in service instructions on page 10.
- 3) Perform brake tests per instructions on page 6.
- 4) Check tire inflation and condition per instructions on page 2.
- 5) Check and adjust drive chain per instructions on pages 10 and 11.
- 6) Check the throttle for smooth operation and insure that it returns to idle position.
- 7) Check the engine stop button for proper operation per instructions on page 6.
- 8) Check all nuts, bolts, fasteners, lug nuts and screws for tightness.

SERVICE INSTRUCTIONS

ENGINE

Refer to engine manufacturer's owner's manual for engine service instructions including engine oil, air filter, spark plug, regular cleaning and adjustment.

CHASSIS LUBRICATION

Inspect daily and lubricate as needed using a light grade oil.

- Foot brake lever pivot points
- Hand brake lever pivot points
- Throttle pivot lever on engine
- Drive Chain — see chain adjustment and lubrication

CHAIN ADJUSTMENT AND LUBRICATION

NOTE: An improperly adjusted chain will jerk on clutch engagement. An excessively loose chain may jump off of drive sprocket which may cause damage.

- Check chain tension every hour for the first three hours of use. Thereafter, check daily and adjust to 3/8 in. slack at top of chain halfway between the front and rear sprockets.
- To adjust the chain, turn bolt (2), raising or lowering idler arm (1) until the correct tension is reached.

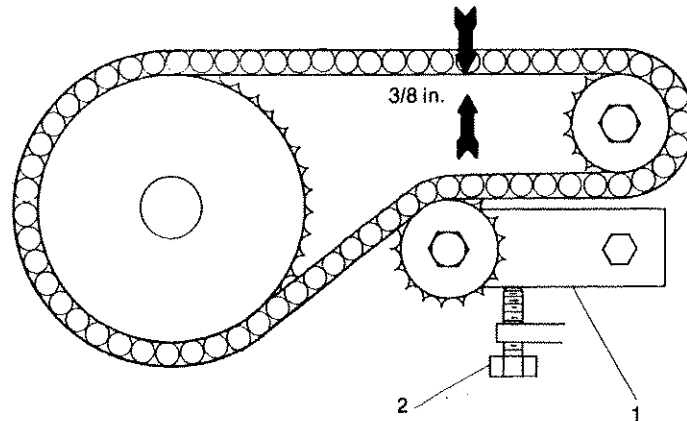

- Lubricate the chain with a graphite type motorcycle chain lubricant spray. This method assures lubricant penetration into moving parts. When oil or grease are used to lubricate the chain, dirt will collect in the lubricant causing rapid wear of the chain and sprocket.
- If the chain becomes dirty or rusty, remove it from the vehicle. Place the chain in a shallow container and cover it with a cleaning solvent. After allowing it to soak and loosen the dirt, work the chain to further loosen dirt. Then allow the solvent to penetrate further. Remove the chain from the solvent and clean the remaining dirt off with a wire brush or a stiff bristle brush. Dry the chain thoroughly with compressed air and apply spray lubricant as explained above. Reinstall chain on the vehicle and adjust the tension.

BRAKE ADJUSTMENT

NOTE: Always adjust the foot brake first.

Foot Brake

Loosen the front hex nut holding the cable in place. Turn the rear nut until slack has been removed from the cable and pedal. Tighten the front hex nut.

Hand Brake

Loosen locknut at hand brake lever. Turn lever adjustment screw to remove slack in the cable. Tighten locknut.

NOTE: Do not adjust the brakes too tightly as this will cause the brake to drag creating unnecessary brake wear. Vehicle should move freely without brake applied.



CAUTION: DO NOT OPERATE THE VEHICLE UNLESS BOTH THE FOOT BRAKE AND HAND BRAKE ARE FUNCTIONING PROPERLY.

TORQUE CONVERTER

- The torque converter clutch (engine-mounted pulley) and driven pulley (rear pulley) should be inspected, cleaned and lubricated every 50 hours and more frequently in dusty or dirty use. If you feel jerky or uneven operation such as slowness to engage or disengage, it is time to inspect, clean and lubricate.
- The pulley surfaces contacting the drive belt must be kept clean and free of dirt, oil and grease.
- Inspect the drive belt daily for signs of wear, fraying, cracking and dirt. Clean or replace as needed. If the sides of the belt become slick or glazed, the performance will be reduced. Glaze may be removed with fine sandpaper to restore the original surface texture.

SERIES 20 DRIVE CLUTCH PARTS BREAKDOWN (MODEL 500)

REFERENCE NUMBER	PART NUMBER	DESCRIPTION	NUMBER REQUIRED
1	TW420132A	Drum, Driver	1
2	TW420132B	Spline Sleeve 5/8 in. Bore	1
3	TW420132C	Shoe Ass'y., Zinc Die Cast	1
4	TW420132D	Spring, Garter, Blue	2
5	TW420132E	Movable Sheave & Splined Hub	1
6	TW420132F	Washer, Stl. 5/8 in. I.D.	2
7	TW420132G	Bushing, Bronze Idler	1
8	TW420132H	Sheave, Fixed 5/8 in. I.D.	1

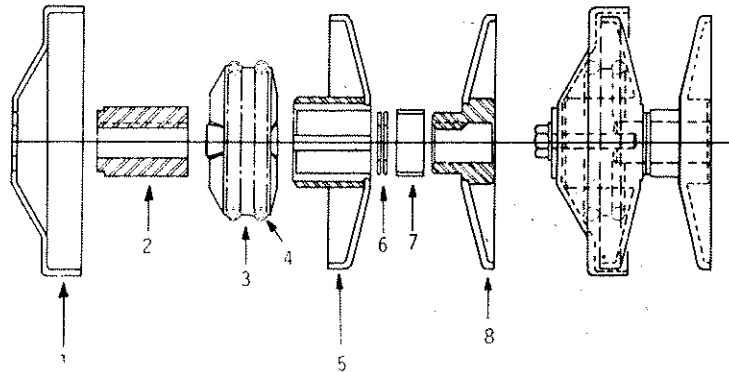

NOTE: Review the above diagram before commencing to remove torque converter. As you remove the torque converter, identify each part and note its exact position to insure proper assembly.

Cover Removal

See cover installation in assembly instructions. Pull the bottom of the cover out slightly and rotate up and over the clutch and pulley. Lift the cover out towards the rear of the vehicle. Do not try to force the cover out towards the front of the vehicle.

Clutch Removal

- 1) Remove bolt and washers securing clutch to engine crankshaft.
- 2) Slide the drum driver (1) off the shaft.
- 3) Slide the shoe assembly (3) off the shaft taking care to note which side faces out.
- 4) Slide the sheave-hub (5) off of shaft.
- 5) Remove the spline sleeve (2).
- 6) Remove washers (6), idler bushing (7) and fixed sheave (8).

Cleaning

Clean all parts in cleaning solvent and dry thoroughly.

Lubrication and Reassembly

Using a light grease or dry lubricant, lubricate with a thin coating the outside of spline sleeve (2), the shoe spring assembly (3& 4) and the inside pulley surfaces (1&5) contacted by the shoe assembly. Reassemble in reverse of disassembly explained above. Do not allow grease to get on drive surfaces of pulleys or on idler bushing.

The driven pulley (rear) should not be removed for cleaning unless excessively dirty. Clean the shaft inside the spring with solvent and allow to dry. Apply a dry lubricant or a few drops of oil to assure free operation.

SERIES 40 DRIVE CLUTCH PARTS BREAKDOWN (MODEL 800)

REFERENCE NUMBER	PART NUMBER	DESCRIPTION	NUMBER REQUIRED
1	TW420135A	Cover & Drive Plate	1
2	TW420135B	Cam, Roller, Std.	3
3	TW420135C	Clip, Spring	3
4	TW420135D	Spring, Extension, Yel., Std.	3
5	TW420135E	Face, Movable & Hub	1
6	TW420135F	Bushing, Guide	2
7	TW420135G	Spring, Compression	1
8	TW420135H	Face, Fixed & Post, 1 In. Bore, 1/4 In. Key	1

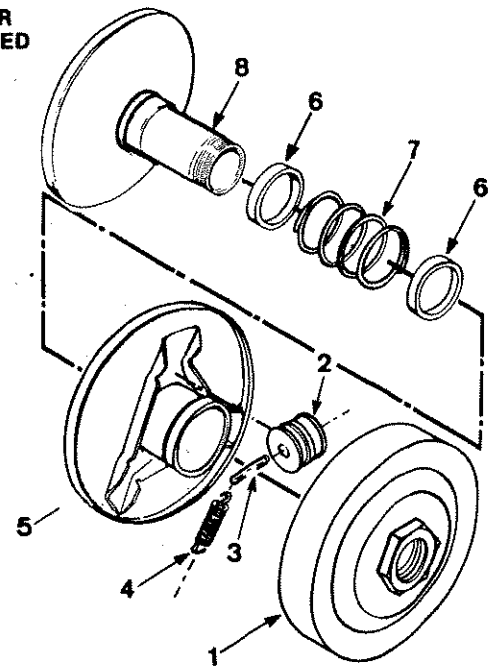

Clutch Removal

- 1) Remove bolt and washers securing clutch to engine crankshaft.
- 2) Place inside pulley face (8) in vise to hold. Do not overtighten as damage to the pulley could occur.
- 3) Loosen cover and drive plate (1) turning counterclockwise.
- 4) Remove components (2) through (7) noting assembly order.

Cleaning

Clean all parts in cleaning solvent and dry thoroughly.

Lubrication and Reassembly

Using a light grease or dry lubricant, lubricate with a thin coating the rollers (2) and the cam surfaces on (1) and (5). Reassemble in reverse of disassembly explained above. Do not allow grease to get on belt drive surfaces of pulleys or on idler center.

Do not remove driven pulley (rear) to clean unless it is excessively dirty. Clean with a cleaning solvent and allow to dry. Lubricate the rear pulley outer slide shaft surface periodically with dry lubricant or a few drops of oil.

Torque Converter Drive Belt Adjustment

The drive belt of the torque converter can be adjusted and should be checked periodically to prevent excessive wear. If the vehicle "creeps" when idling, the belt is too tight and should be loosened. If the engine needs to be run at a relatively high speed to move the vehicle or excessive belt slippage is present under load, the belt is too loose and readjustment is necessary.

To adjust the belt, remove the belt cover, loosen the engine mounting bolts and slide the engine to obtain proper belt adjustment. The belt tension should be adjusted so that with the engine idling, the vehicle will not tend to "creep" forward. Replace the belt cover.

STORAGE INSTRUCTIONS

For winter or other long-term storage perform the following:

- 1) Making sure the engine is cold, empty the gasoline tank. Then start the engine to remove any gasoline from the carburetor. If gasoline is not removed it will build up varnish and gum deposits which will reduce engine performance.
- 2) Lubricate the engine by removing the spark plug and pouring a small amount of motor oil into the cylinder. Then slowly crank the engine to coat all surfaces inside the cylinder with oil. Replace the spark plug.

SPEECO ROUGHRIDER WARRANTY

ENGINE

SpeeCo does not warranty the engine. The engine manufacturer provides his own warranty. See Engine Owner's Manual.

CHASSIS, BODY AND DRIVE TRAIN

SpeeCo guarantees material and workmanship of this vehicle and components for a period of ninety days except as noted below. We will repair or replace at our option any component we determine to be defective.

WARRANTY LIMITATIONS AND COMPONENTS NOT COVERED BY WARRANTY

- Engine — For maintenance, repair or replacement see Engine Owner's Manual.
- Clutch and Driven Pulley — Maximum of thirty days material and workmanship.
- Normal wear is not covered by warranty on such components as tires, brakes, cables, chains, drive belts, sprockets, pulleys, bearings, clutch rotors, etc. They are subject to wear depending on use, maintenance and operation.
- This product and packaging was in good condition when shipped from the factory. Shipping damage claims should be made with the delivering carrier at the time of delivery, Not With SpeeCo.
- Damage due to improper assembly, improper use, failure to read and follow owner's manual, alteration, competitive use, abuse, neglect and improper maintenance is not covered by the warranty.

All freight and transportation charges to return parts and components to the factory for inspection are to be paid by the consumer. Do not send components to the factory for inspection prior to receiving a factory "return authorization" from your dealer or the factory.

SpeeCo, Inc. is not liable for any damage claim or liability claim, personal or otherwise, resulting from the use or operation of this vehicle.



Roughrider

THREE-WHEEL ALL-TERRAIN CYCLES

MODEL 500 5 h.p. - 206cc

MODEL 800 8 h.p. - 319cc

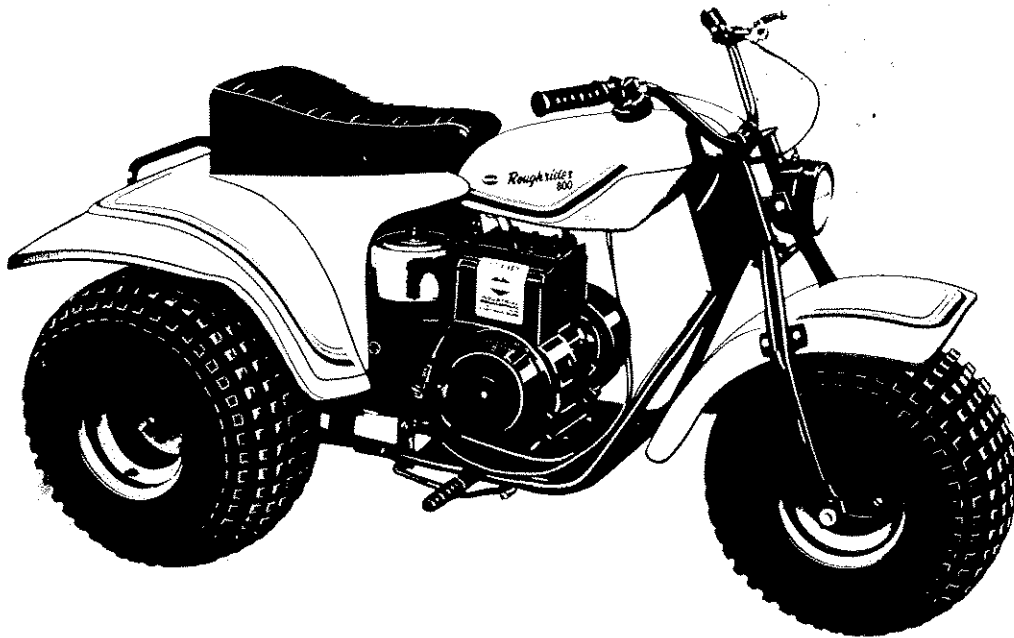

OWNER'S MANUAL

FOR FUTURE REFERENCE WHEN ORDERING PARTS, RECORD THE FOLLOWING DATA FROM YOUR VEHICLE.

_____ MODEL NO.

_____ SERIAL NO. FROM TAG ON MAIN FRAME

_____ ENGINE SERIAL NO. FROM CARBURETOR SIDE OF ENGINE (MODEL 500)
FROM TOP OF ENGINE (MODEL 800)

SPECIAL  PRODUCTS

15000 W. 44TH AVE. GOLDEN, COLO. 80401 • 303-279-5544