

EXPLODED DIAGRAM OF 7116

1.0

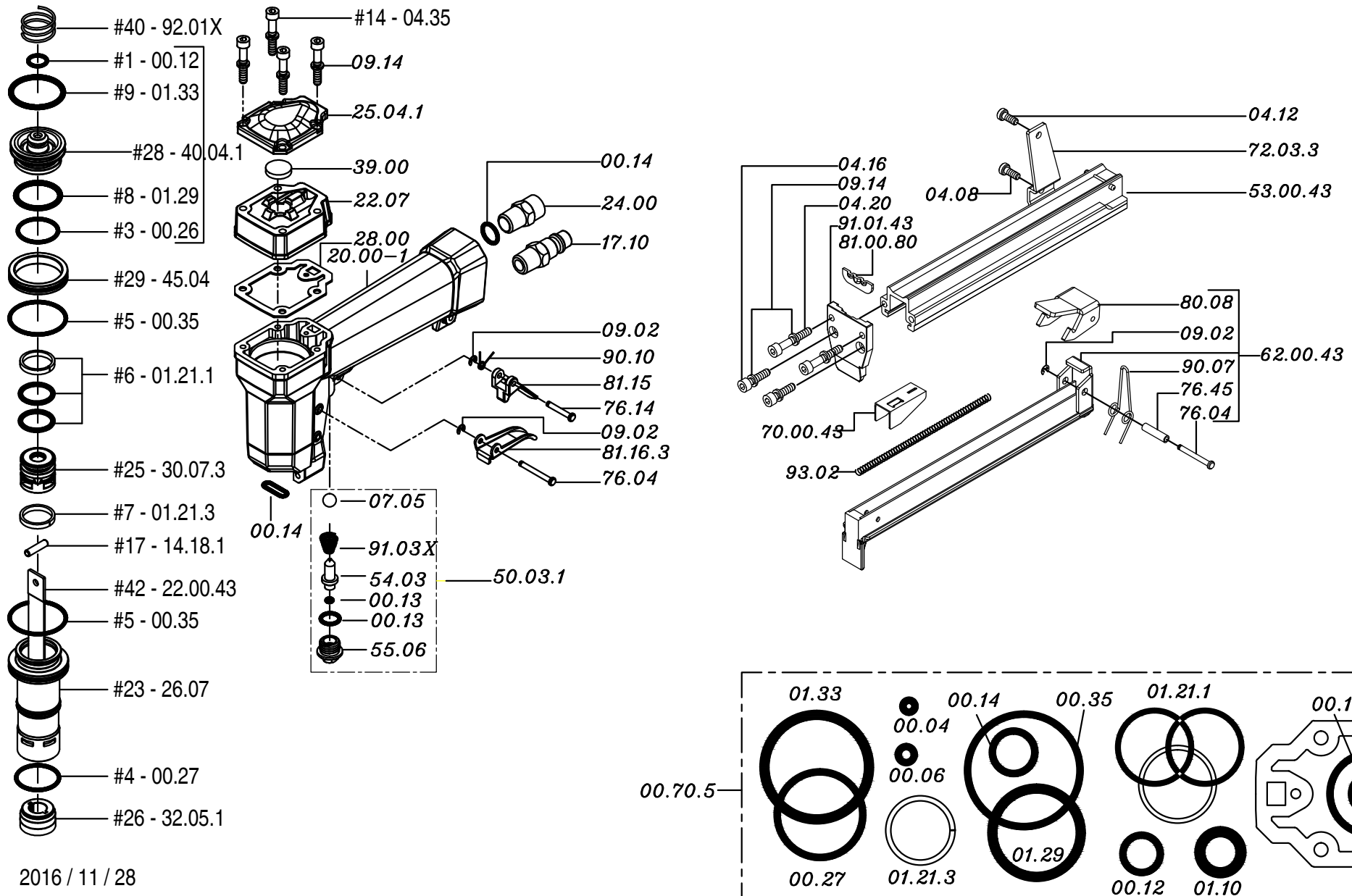

PART LIST OF 7116

| No. | Code. | Description | PRICE | No. | Code. | Description | PRICE |
|-----|---------|------------------------|-------|-----|----------|------------------|-------|
| 1 | 00.12 | O-Ring | | 36 | 81.09 | Trigger | |
| 2 | 00.14 | O-Ring | | 37 | 81.15 | Safety | |
| 3 | 00.26 | O-Ring | | 38 | 90.07 | Spring | |
| 4 | 00.27 | O-Ring | | 39 | 90.10 | Spring | |
| 5 | 00.35 | O-Ring | | 40 | 92.01X | Spring | |
| 6 | 01.21.1 | Gasket | | 41 | 93.02 | Spring | |
| 7 | 01.21.3 | Gasket | | 42 | 22.00.43 | Driver(7116) | |
| 8 | 01.29 | O-Ring | | 43 | 53.00.43 | Slider | |
| 9 | 01.33 | O-Ring | | 44 | 62.00.43 | Magazine(7116) | |
| 10 | 04.08 | Screw | | 45 | 70.00.43 | Pusher(7116) | |
| 11 | 04.12 | Screw | | 46 | 81.00.80 | Nose | |
| 12 | 04.16 | Screw | | 47 | 91.00.43 | Nose Plate(7116) | |
| 13 | 04.20 | Screw | | | 00.70.5 | O-RING KIT | |
| 14 | 04.35 | Screw | | | | | |
| 15 | 09.02 | Elastic Ring | | | | | |
| 16 | 09.14 | Washer | | | | | |
| 17 | 14.18.1 | Pin | | | | | |
| 18 | 17.10 | Air Plug 1/4" | | | | | |
| 19 | 20.00 | Body | | | | | |
| 20 | 22.07 | Head | | | | | |
| 21 | 24.00 | Silencer | | | | | |
| 22 | 25.04.1 | Exhaust deflector | | | | | |
| 23 | 26.07 | Cylinder | | | | | |
| 24 | 28.00 | Gasket | | | | | |
| 25 | 30.07.3 | Piston | | | | | |
| 26 | 32.05 | Bumper | | | | | |
| 27 | 39.00 | Exhaust gasket | | | | | |
| 28 | 40.04.2 | Valve ass'y. | | | | | |
| 29 | 45.04 | Ring | | | | | |
| 30 | 50.03 | Trigger Valve Assembly | | | | | |
| 31 | 72.03.3 | Support | | | | | |
| 32 | 76.04 | Pin | | | | | |
| 33 | 76.14 | Pin | | | | | |
| 34 | 76.45 | Pin | | | | | |
| 35 | 80.08 | Trigger | | | | EX-WORK | |