

Stage One
10 Rifle 10 Pistol 4+ Shotgun

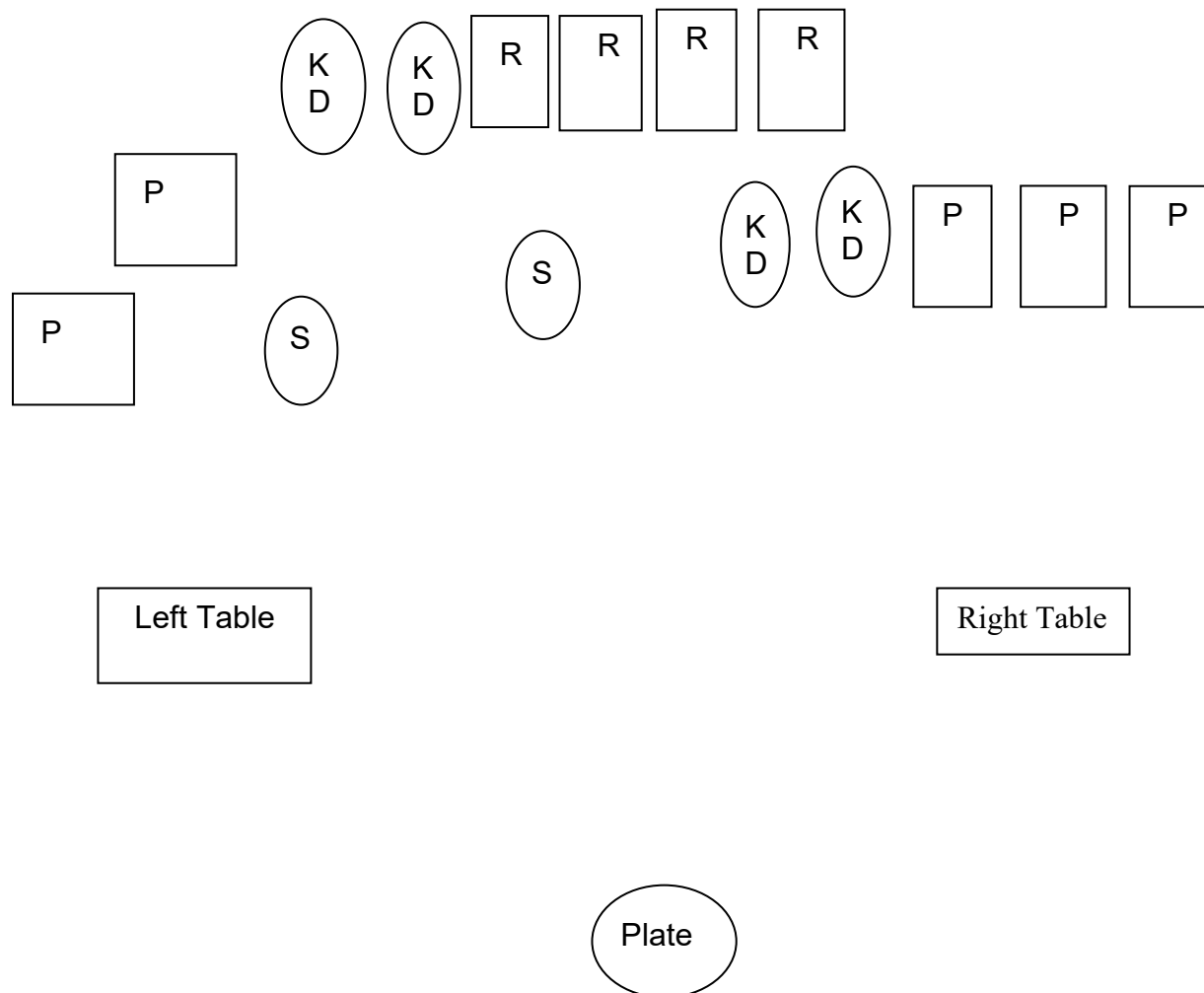

Staging: Pistols holstered, shotgun staged on table of choice rifle in hand.

Gun Order: Rifle, then pistols or shotgun.

Scenario: Standing one foot touching plate, rifle in hand, when ready say “**Lets Go!**” ATB with rifle engage the rectangles with one round each then the knock downs one with one round each then the rectangles with one round each. From the right table with five pistol rounds engage three rectangles and the knock downs with one round each. From the left table with remaining pistol rounds engage the two pistol targets with at least one round each. With shotgun engage shotgun targets until down. Knock downs are a one second bonus. Knock downs left standing are not misses.

Savannah River Rangers 11-21-21

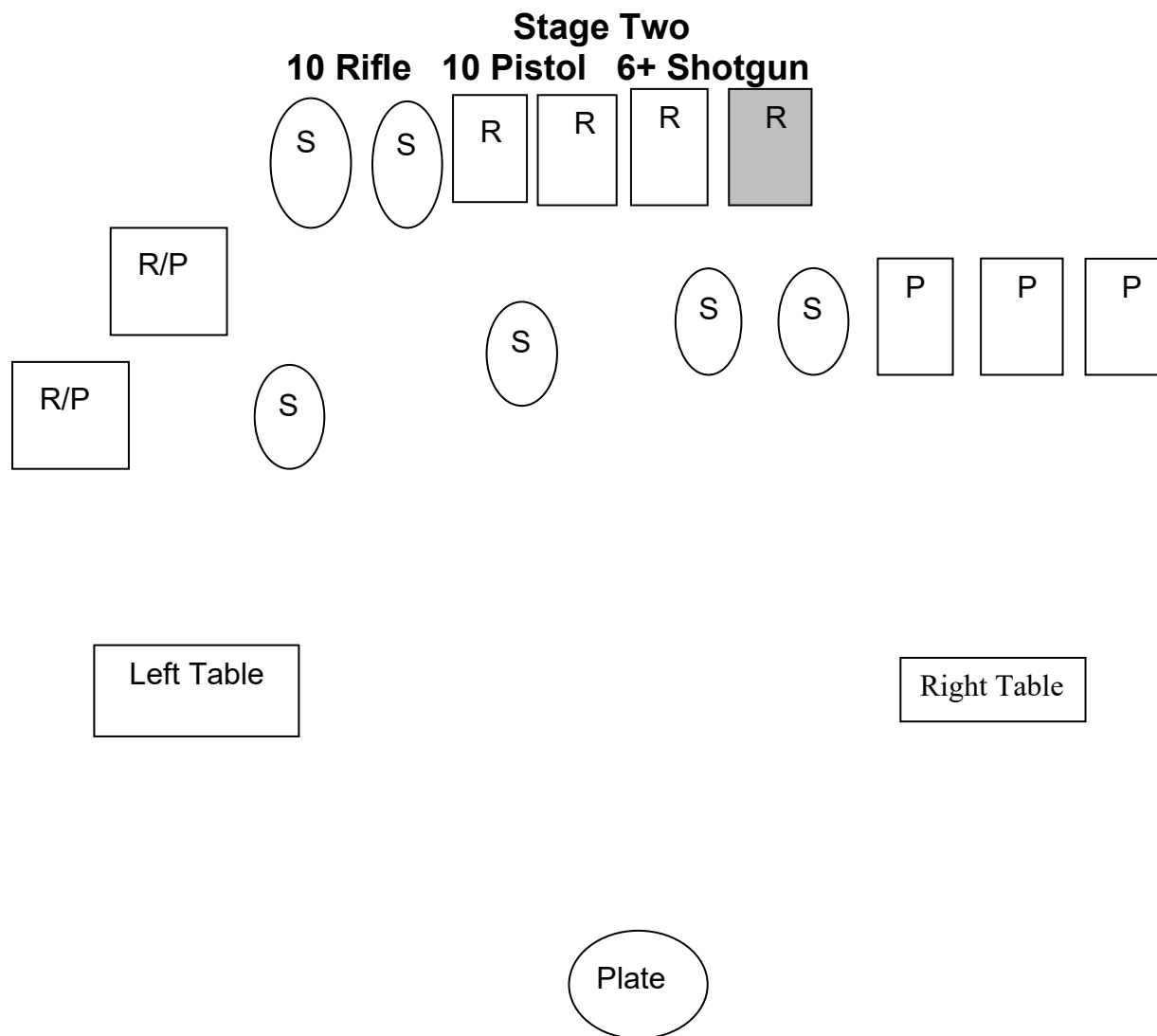

Staging: Pistols holstered, rifle staged on right table, shotgun staged on left table.

Gun Order: Pistol, rifle, shotgun, pistol.

Scenario: Standing behind right table, holding bottle in both hands, when ready say, ***“It’s might dry country”*** ATB With five pistol rounds engage the three right targets in a 1-2-2 sweep. Then with rifle engage the three rear targets in a 1-2-2 sweep and the left two targets in a 1-2-2 sweep. Move to the left table with shotgun knock down shotgun targets in any order. Then with pistols engage the left two targets in a 1-2-2 sweep.

Stage Three
10 Rifle 10 Pistol 1 Shotgun

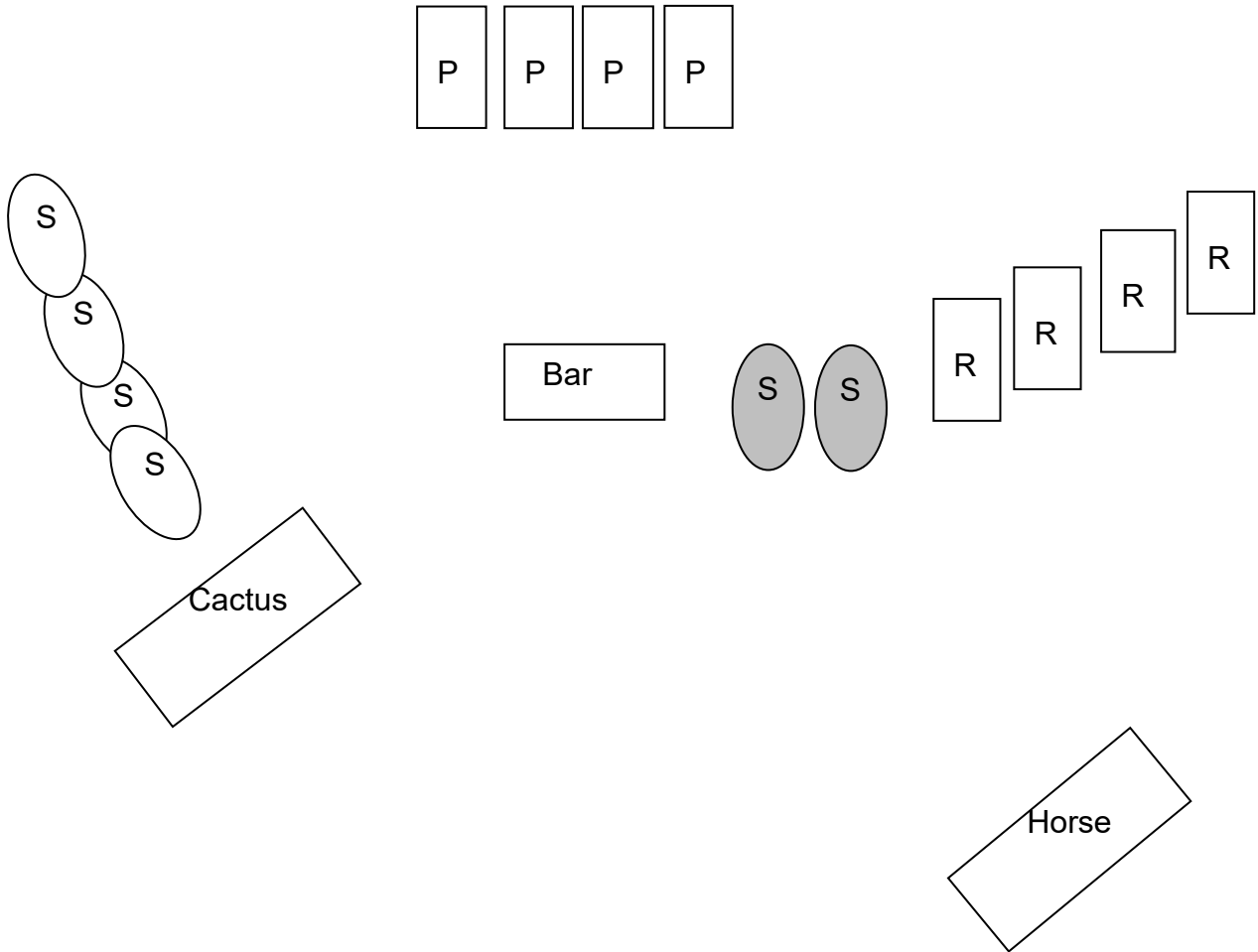

Staging: Pistols holstered, rifle staged on horse, shotgun on cactus.

Gun order: rifle, shotgun, pistols.

Scenario: Standing at the horse with tail in both hands, when ready say ***“Does he kick”*** ATB With rifle engage rifle targets in a progressive sweep. Make rifle safe and move to the cactus. With shotgun engage shotgun targets with ONE round. With pistols engage pistol targets in a progressive sweep. Pistols may be shot anywhere between cactus and bar. Shotgun targets knocked down are a one second bonus. Shotgun targets left standing are not misses.

Stage Four
10 Rifle 10 Pistol 2+ Shotgun

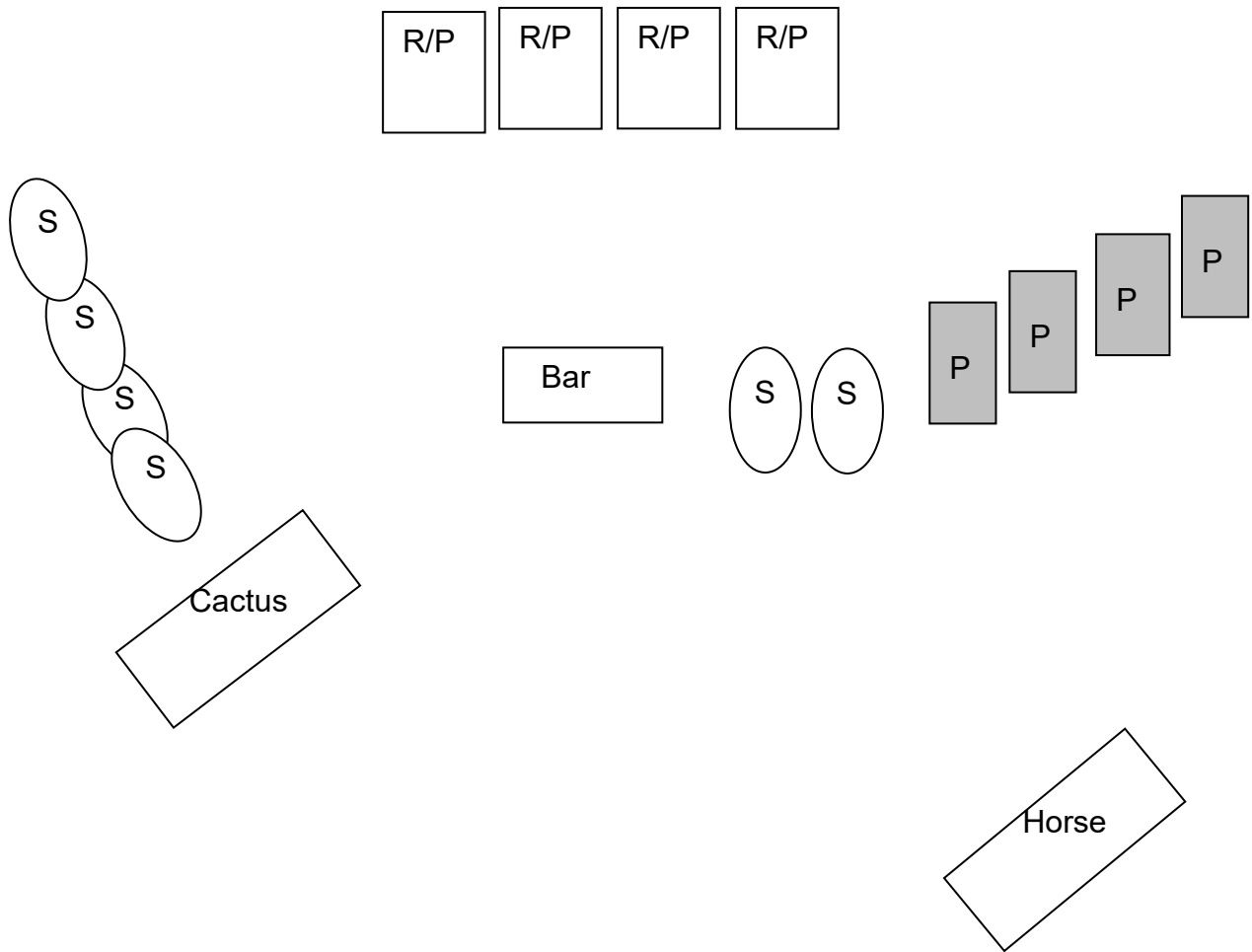

Staging: Pistols holstered, Rifle staged on cactus, shotgun staged on horse.

Gun Orded: Shotgun, rifle, pistols.

Scenario: Standing at the horse. Reins in both hands. When ready say, “**Whoa mule**” ATB With shotgun engage shotgun targets in front of the horse until down. Then move to the cactus and engage remaining shotgun targets until down. Then with rifle engage an outside target with three rounds and the two inside targets with one round each then engage the other outside target with three rounds and the two inside targets with one round each. With pistols engage targets per rifle instructions. Pistols may be shot anywhere between cactus and bar

Stage Five
10 Rifle 10 Pistol 4 Shotgun

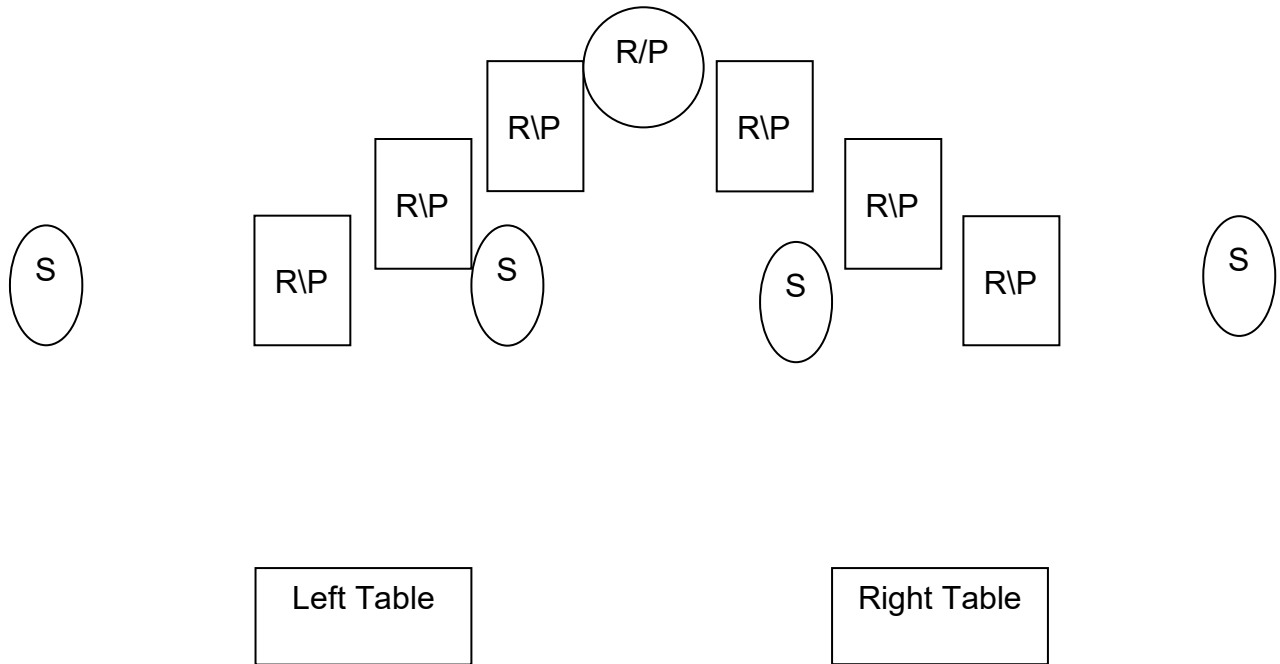

Staging: Pistols holstered, rifle and shotgun staged on table of choice.

Gun order: Rifle not last.

Scenario: Standing behind table of choice, hands on gun of choice, when ready say ***“Rustlers!”*** With rifle engage three rectangles with three rounds each then engage the circle with one round. Move to the other table and with pistols engage the other three rectangles and the circle per rifle instructions. With shotgun engage shotgun targets until down.

Stage Six
10 Rifle 10 Pistol 4+ Shotgun

\

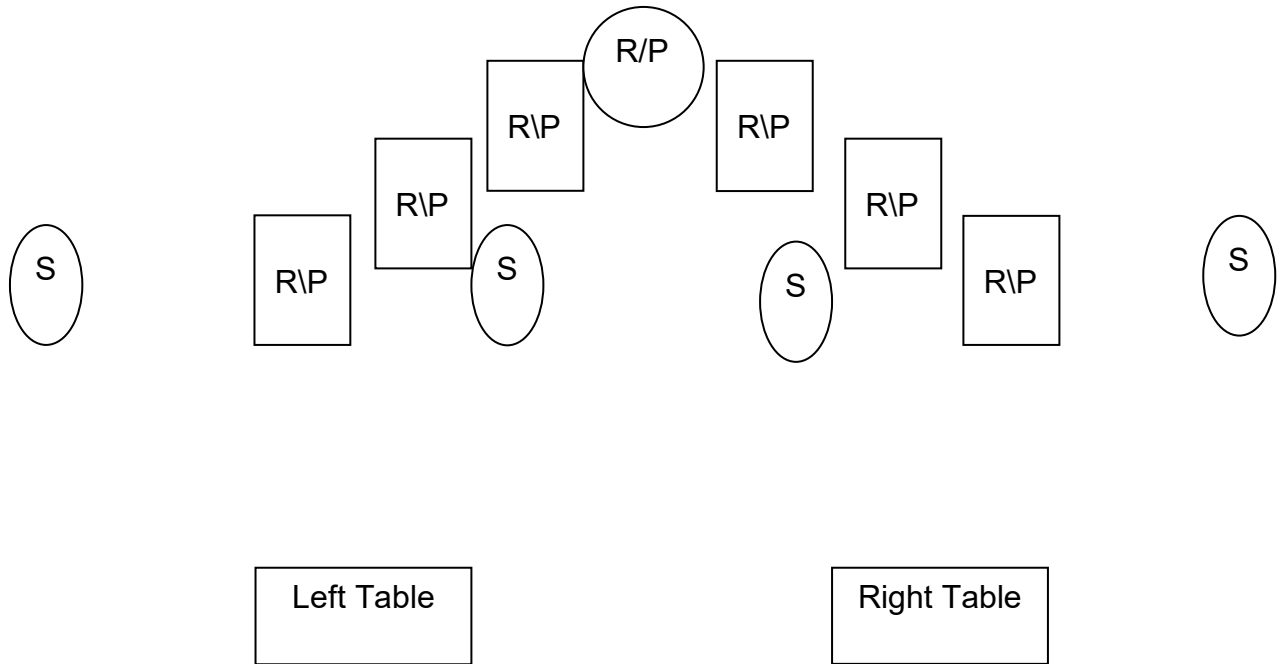

Staging: Pistols holstered, rifle staged on table of choice, shotgun staged on table opposite of rifle.

Gun order: shotgun, rifle pistols

Scenario: Standing behind table of choice hands on hat. When ready say, “***Stampede!***” ATB With shotgun, knock down two shotgun targets. Move to the other table and knock down the remaining shotgun targets. Then with rifle engage the targets in a Nevada sweep double tapping every other target. Then with pistols engage targets per rifle instructions.

Savannah River Rangers 11-21-21