

INDUSTRIAL DIESEL ENGINE

KUBOTA 05 SERIES (3-cylinder)

# D1105-E4B

## RATED POWER

18.5kW @ 3000rpm

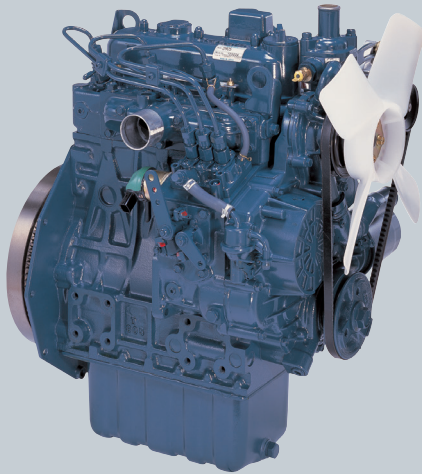

Photograph may show non-standard equipment.

## PERFORMANCE CURVE

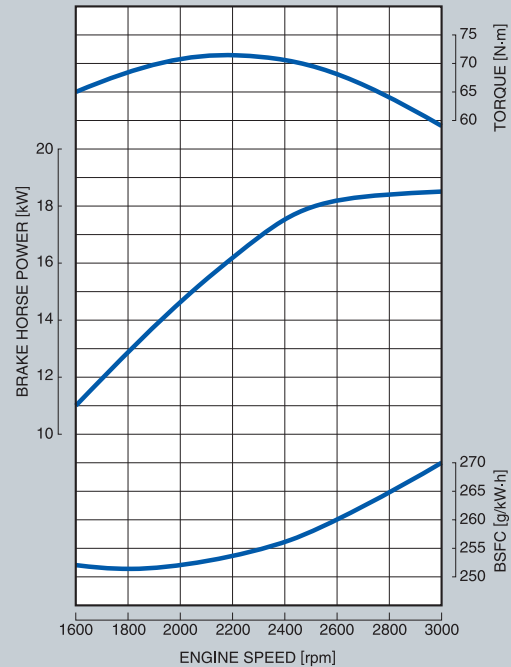

## FEATURES and BENEFITS

### Emissions

Kubota engine less than 19kW meets emission standards over the NRTC and also meets the NTE requirements. By suppressing the output, Kubota 05 series have realized smooth transition from E3 to E4.

### Durable Power

The D1105 is a leading engine model among Kubota 05 series engines and is used for various applications. D1105 offers seamless transition from E3 to E4 by maintaining the same footprint and hardware mounting points.

### Option

A variety of engine accessory options is also available.

# KUBOTA 05 SERIES D1105-E4B

## GENERAL SPECIFICATION

Model		D1105-E4B
Emission Regulation		Tier 4
Type		Vertical 4-cycle Liquid Cooled Diesel
Number of Cylinders		3
Bore	mm (in)	78.0 (3.07)
Stroke	mm (in)	78.4 (3.09)
Displacement	L (cu.in)	1.123 (68.53)
Combustion System		IDI
Intake System		Naturally Aspirated
Maximum Speed	rpm	3000
Output: Gross Intermittent	kW	18.5
	hp	24.8
	ps	25.2
Direction of Rotation		Counterclockwise Viewed on Flywheel
Oil Pan Capacity	L (gal)	5.1 (1.35)
Starter Capacity	V-kW	12-1.2
Alternator Capacity	V-A	12-40
Length	mm (in)	497.8 (19.60)
Width	mm (in)	396.0 (15.59)
Height (1)	mm (in)	608.7 (23.96)
Height (2)	mm (in)	233.5 (9.19)
Dry Weight	kg (lb)	93.0 (205.0)

\*Specification is subject to change without notice.

\*Output: Gross Intermittent SAE J1995

\*Dry weight is according to Kubota's standard specification.  
When specification varies, the weight will vary accordingly.

## DIMENSIONS

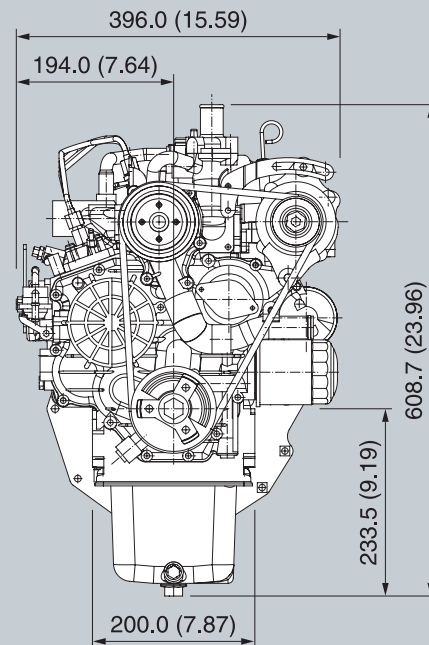
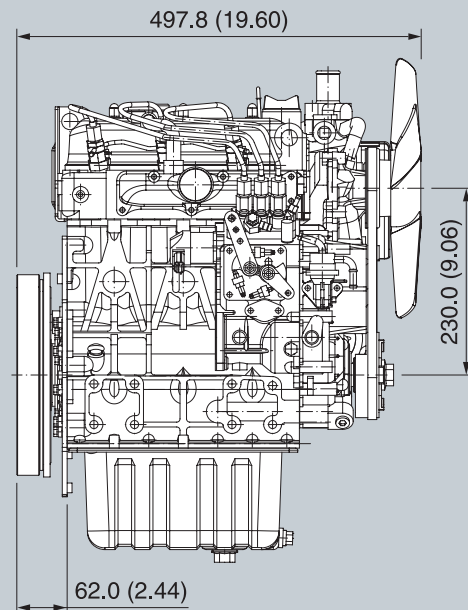

## KUBOTA Engine America Corporation

505 Schelton Road, Lincolnshire, IL 60069

Phone: 847-955-2500 Fax: 847-955-2699

[www.kubotaengine.com](http://www.kubotaengine.com)