

GENERATOR DIESEL ENGINE

Kubota 05 Series (3-Cylinder)

D1005-E4BG



Standby Power¹

9.8 kW @ 1800 RPM

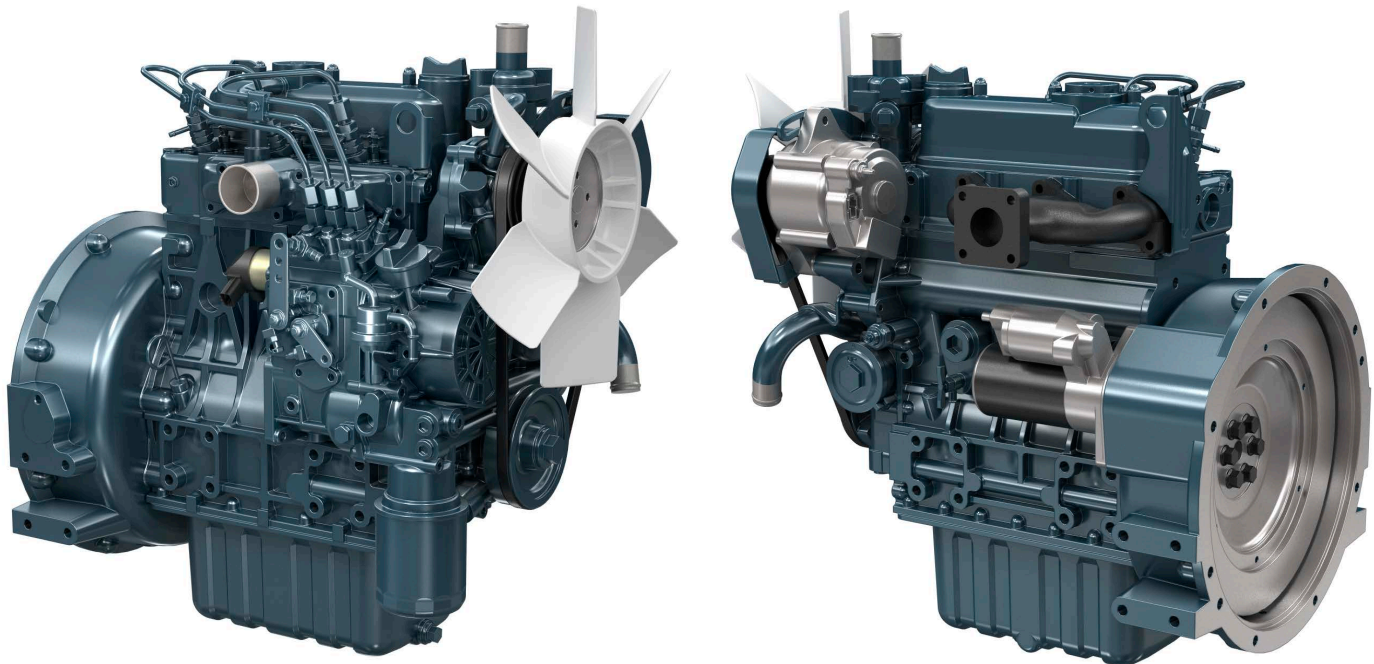

Photograph may show non-standard equipment.

Features and Benefits

Emissions

Kubota's emission department was created to focus exclusively on environmental concerns. We take all possible measures to ensure Kubota engines meet or exceed all required emission regulations for the necessary certifications. Kubota offers multiple solutions with the same engine footprint that meets various emission levels.

Fuel Flexibility

Kubota's engine lineup has a variety of fuel options that include diesel, gasoline, liquid propane and natural gas. By offering these options, customers are guaranteed installation compatibility and fuel flexibility all within the same engine footprint.

Quality

Kubota's generator drive engine solutions are powerful, durable and reliable offering flexible options. Quality components and innovative engineering ensure all Kubota engines provide industrial strength and ultimate performance regardless of fuel choice.

Global Distribution

Because Kubota is continuously expanding our distribution network, we are able to support our customers worldwide. Kubota delivers exceptional service, sales support, engineering support, parts supply and product training everywhere Kubota engines are used.

For Earth, For Life
Kubota

D1005-E4BG

Engine Specifications

Engine model	D1005-E4BG	
Emission regulation	EPA/CARB Tier 4	
Type	Vertical, water cooled 4-cycle diesel engine	
Cylinders	3	
Bore and stroke	mm (in)	76.0 × 73.6 (2.99 × 2.90)
Displacement	L (cu. in)	1.001 (61.1)
Aspiration	Naturally aspirated	
Aftertreatment	NA	
Standby output/speed¹	kW (HP) / rpm	9.8 (13.1) / 1800
Continuous output/speed¹	kW (HP) / rpm	8.7 (11.7) / 1800
Fuel consumption	g / kWh (lb / HPh)	247.0 (0.406)
Combustion system	IDI	
Fuel system	In-line pump	
Length x width x height (Without Aftertreatment)	mm (in)	551.3 x 392.3 x 625.6 (21.7 x 15.4 x 24.6)
Dry weight²	kg (lb)	110 (242)

Specifications are subject to change without notice.
Dimensions and dry weight are according to Kubota's standard specification.
Dimensions and weight depend on completed specifications.

1: SAE J1349 gross intermittent

2: Excludes cooling fan

Dimensions

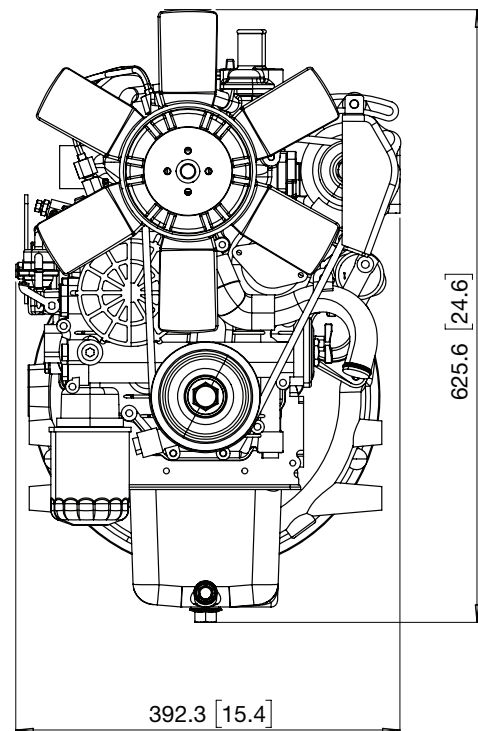
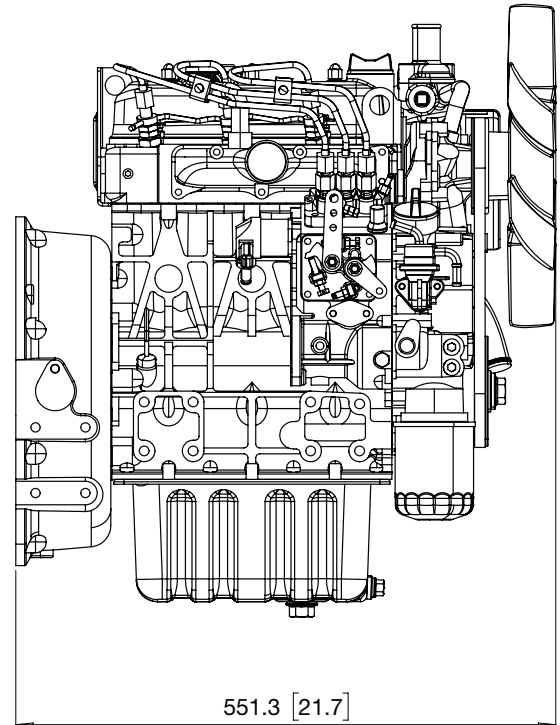

KUBOTA Engine America Corporation

505 Schelster Road, Lincolnshire, IL 60069

P: 847.955.2500 | kubotaengine.com

KEAMKT-0151 07.2023

For Earth, For Life
Kubota