



Achieving High Strength, Ductility, and Durability in Flexural Members Reinforced with Fiber-Reinforced Polymer Rebars by Using UHP-FRC

Shih-Ho (Simon) Chao, Ph.D., P.E.

Professor of Civil Engineering, University of Texas at Arlington



American Concrete Institute

University of Texas at Arlington (2nd largest campus of UT System)



Department of Civil Engineering



Civil Engineering Laboratory Building

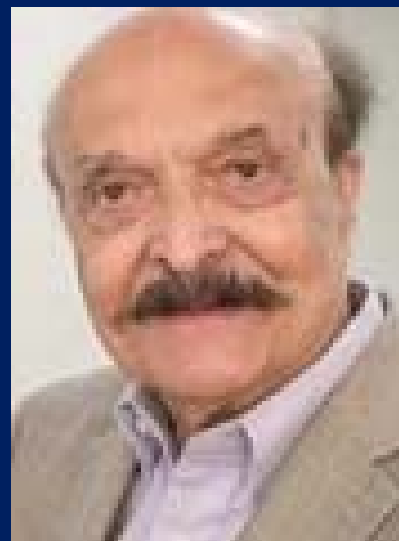

Dr. Surendra P. Shah
Presidential Distinguished Professor of Civil Engineering
Structures and Materials
Member of National Academy of Engineering
Director, Center for Advanced Construction Materials (CACM) at UT Arlington

Ultra-high-performance fiber-reinforced concrete (UHP-FRC)

- High compressive strength
- High compressive ductility
- High cracking resistance
- High shear strength

Fiber-reinforced polymer (FRP) rebars

- High tensile strength
- Noncorrosive

Structural Members

- High durability (highly corrosion resistant)
- High flexural/shear strength
- High stiffness
- High ductility
- High resilience

§ High strength, ductility, durability, and resilience cannot happen simultaneously in conventional RC members design by current design approach

Load vs Deflection behavior

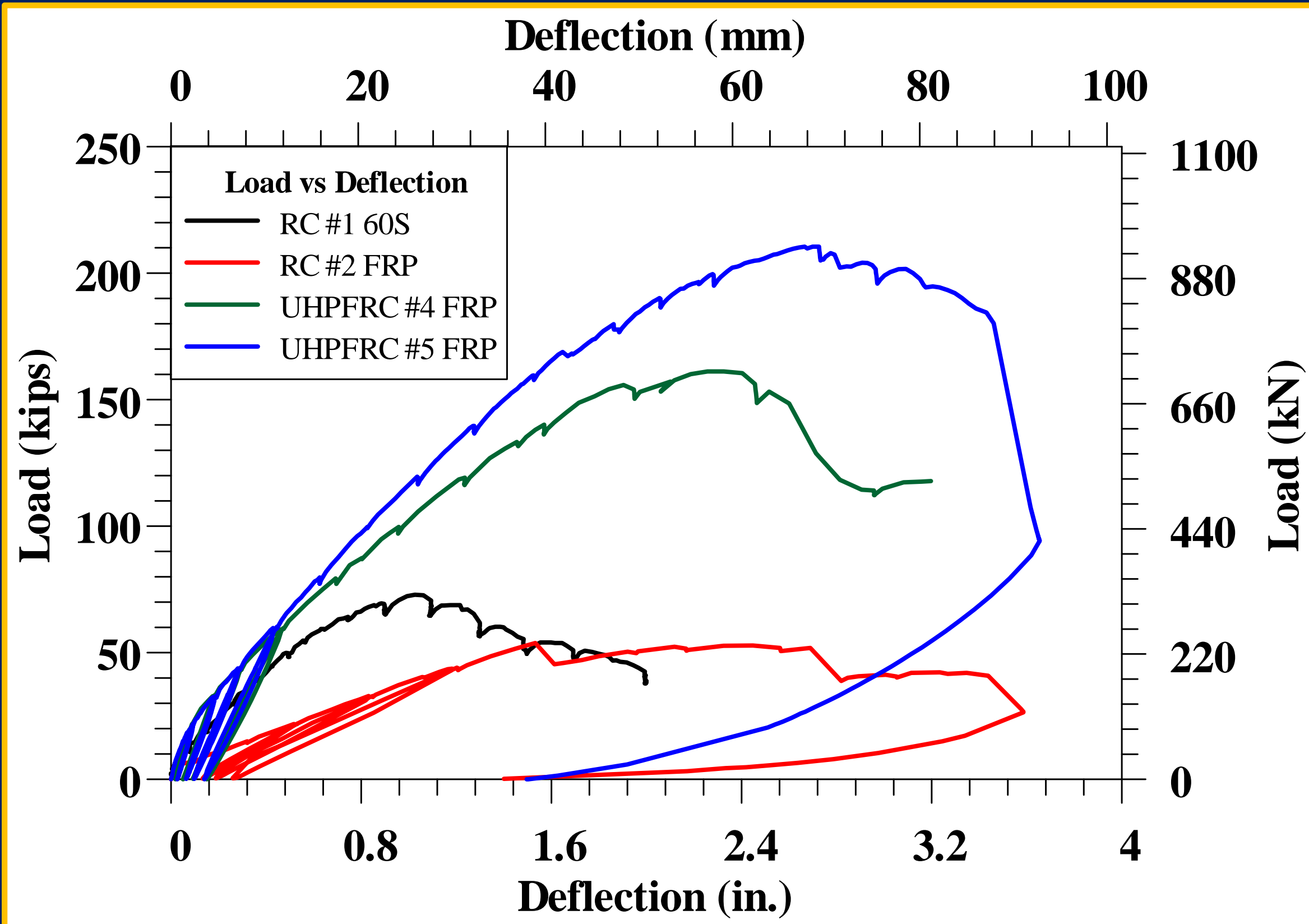

Fiber-Reinforced Polymer (FRP) reinforcing bars

- ✓ High-strength FRP bars can reduce reinforcement congestion.
- ✓ Corrosion resistant – exposure to deicing salts, seawater
- ✓ Lighter than steel (~ 75% lighter).

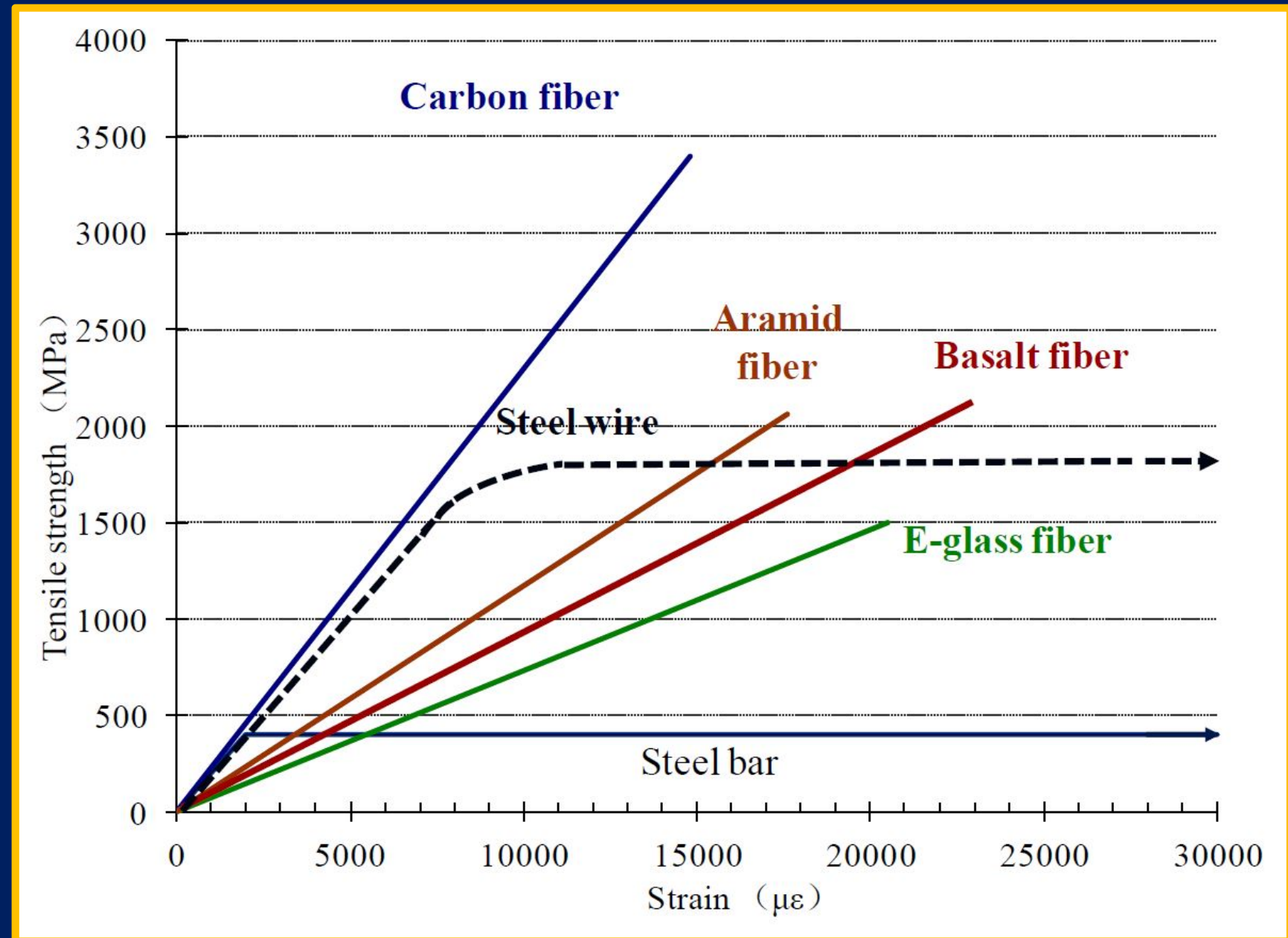

Stress-strain relationship of various FRP bars, Wu et al. 2012

RC #2 beam (Plain Concrete + BFRP bar)



Low rebar axial stiffness \rightarrow large crack width (lower flexural stiffness) and reduced shear resistance (due to reduced aggregate interlock, compression zone, and dowel strength)

FRP rebars with conventional concrete

- The maximum usable compressive strain of plain concrete (at a post-peak stress of approximately 80% of the peak stress), ϵ_{cu} , is 0.003 (ACI 318-19 and 2017 AASHTO LRFD).
- ACI 440 (2015) uses a **conservative design** for concrete members reinforced with FRP bars because both concrete and FRP bars are brittle materials.

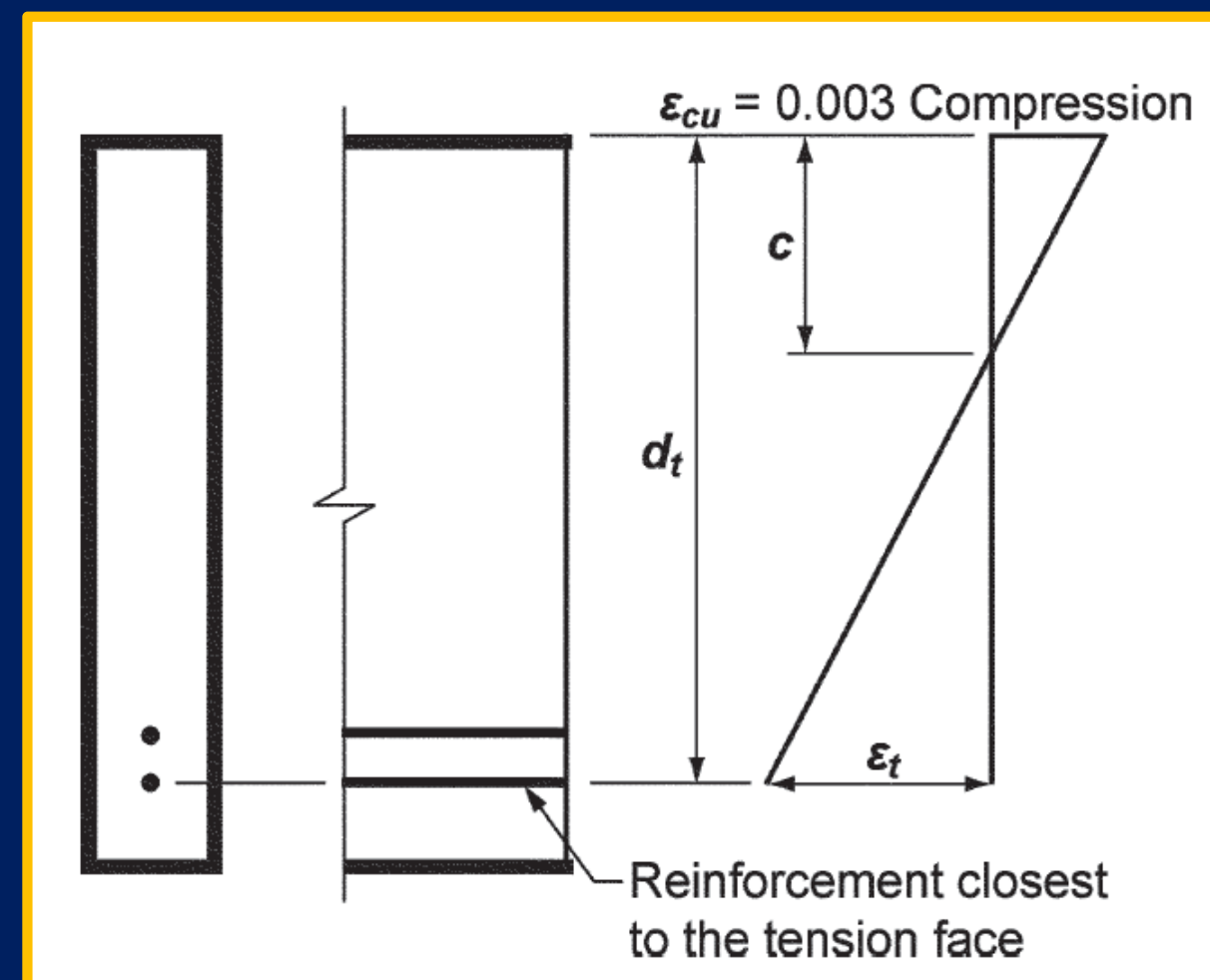
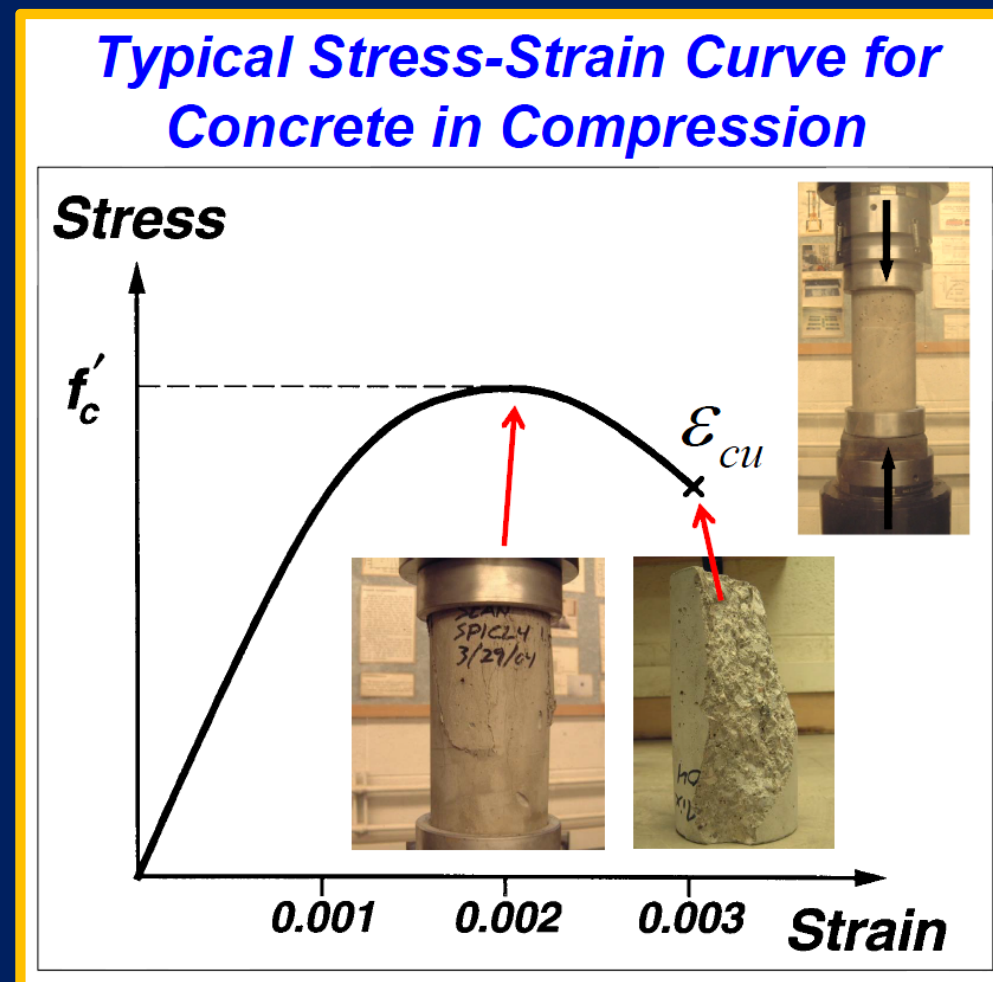

Comparison of typical conventional concrete and UHP-FRC

Properties of Concrete	Conventional Concrete	UHP-FRC
Ultimate Compressive Strength	< 8,000 psi (55 MPa)	18,000 to 30,000 psi (124 to 207 MPa)
Early (24-hour) compressive strength	< 3000 psi (21 MPa)	10,000 – 12,000 psi (69 to 83 MPa)
Flexural Strength	< 670 psi (4.6 MPa)	2,500 to 6,000 psi (17 to 41 MPa)
Shear strength	< 180 psi (1.2 MPa)	> 600 psi (4.1 MPa)
Direct Tension	< 350 psi (2.5 MPa)	up to 1,450 psi (10 MPa)
Rapid Chloride Penetration Test	2000-4000 Coulombs passed	Negligible (< 100 Coulombs passed)
Ductility	Negligible	High ductility
Ultimate Compressive Strain, ϵ_{cu}	0.003	0.015 to 0.03
Confining	Negligible	High confining capability

Traditional Design Concept for Reinforced Concrete

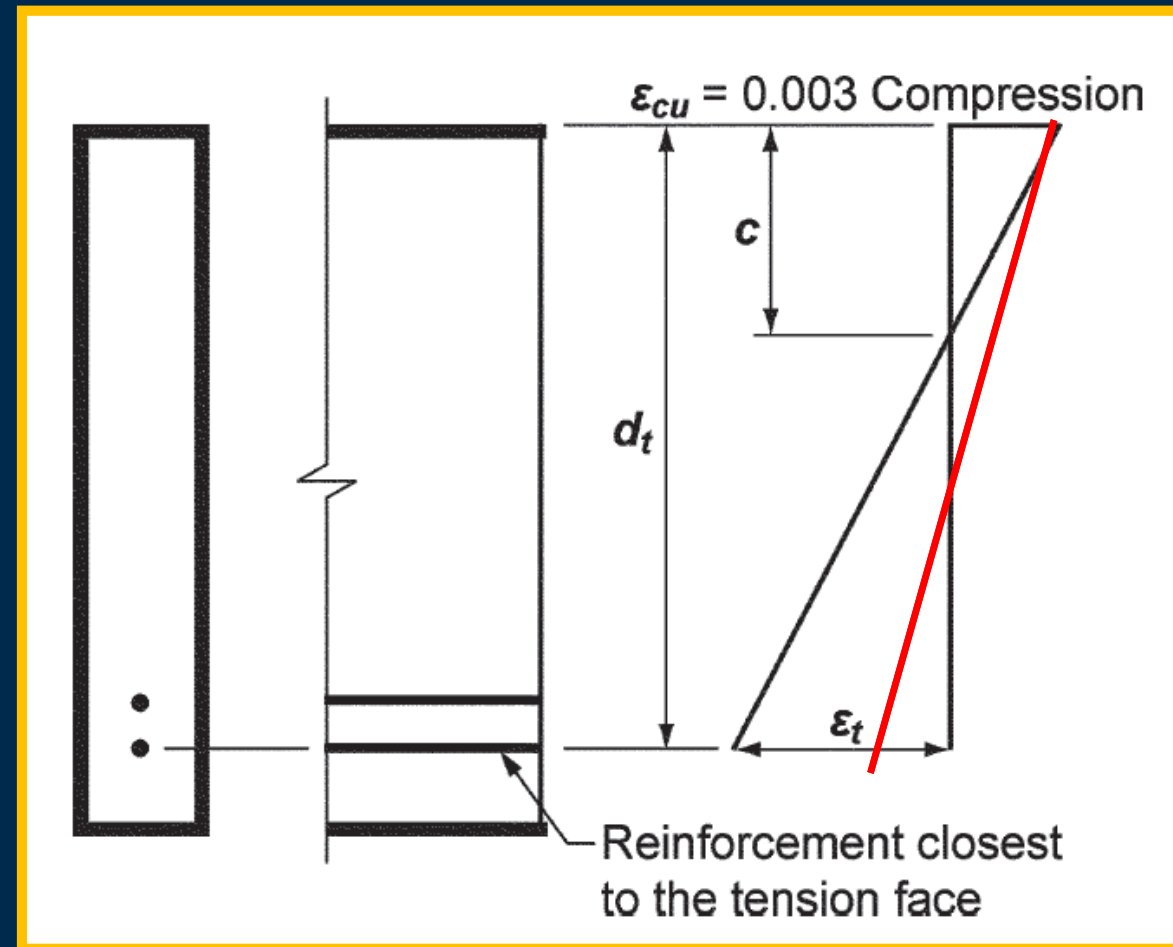
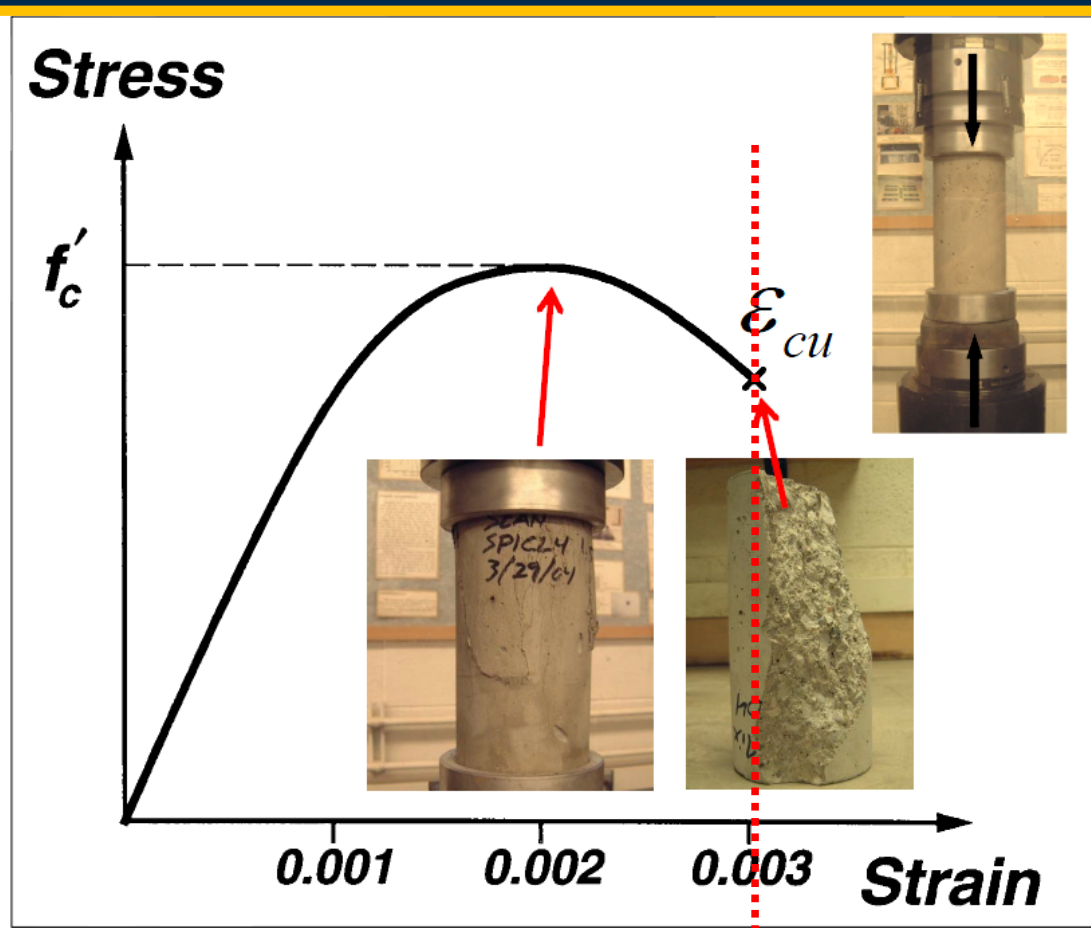

$$\frac{c}{d_t} = \frac{\epsilon_{cu}}{\epsilon_{cu} + \epsilon_t}$$

Value of Ultimate Compressive Strain in concrete (ϵ_{cu}) = 0.003

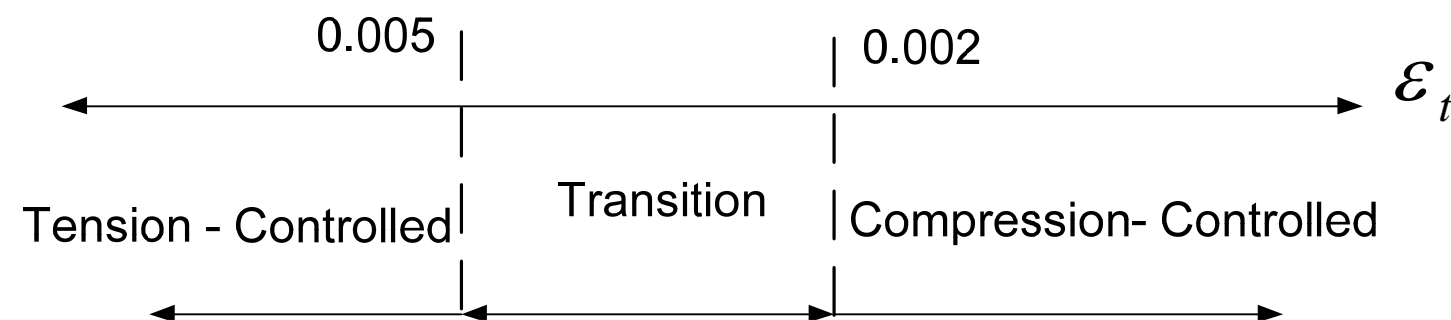

Compressive Ductility of UHP-FRC

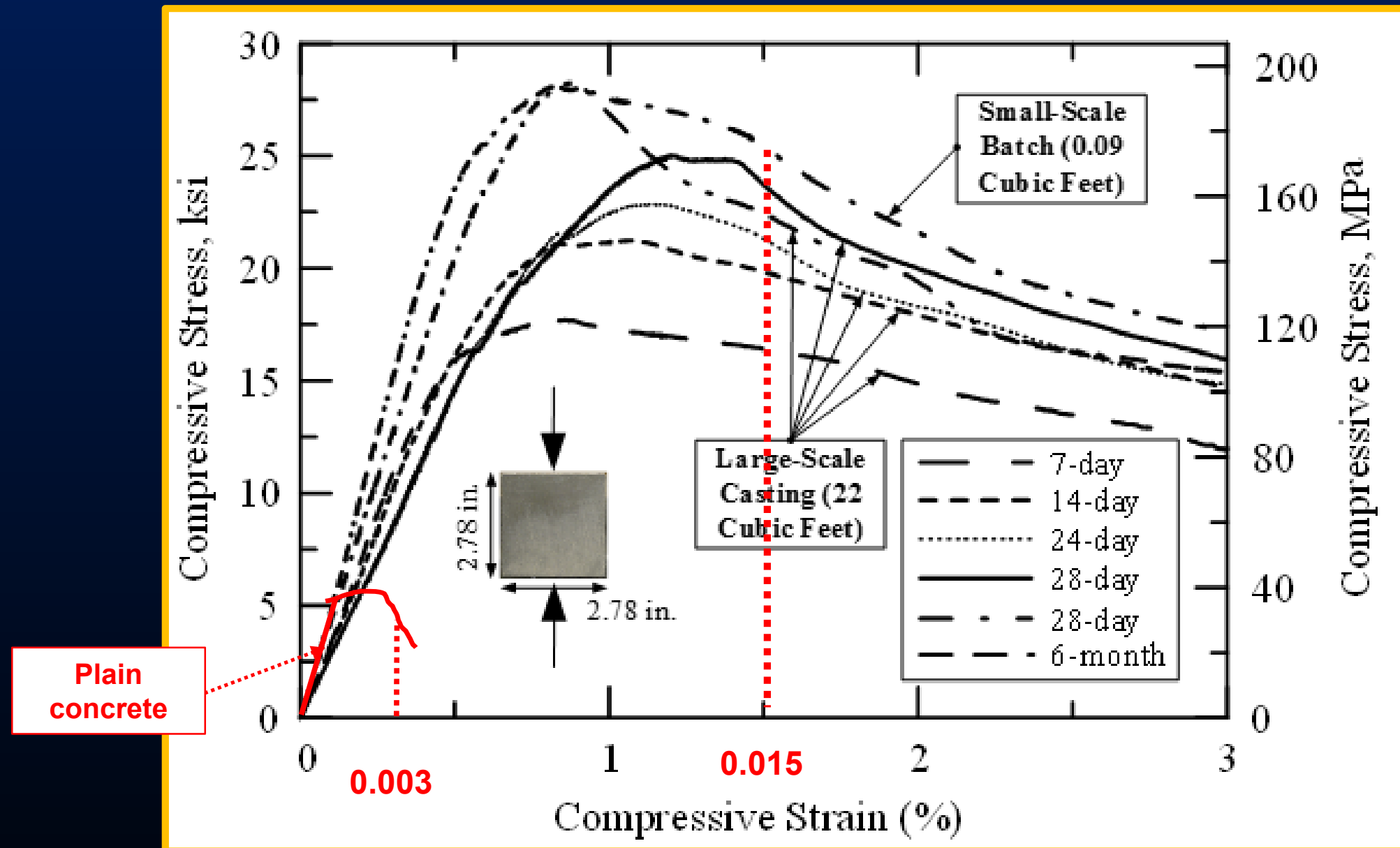

Aghdasi, P., Heid A. E., and Chao, S.-H. (2016). "Developing Ultra-High-Performance Fiber-Reinforced Concrete for Large-Scale Structural Applications," *ACI Materials Journal*, V. 113, No. 5, September-October 2016, pp. 559-570.

1
2 **Strains of UHP-FRC beam measured by high resolution digital image correlation (DIC) technology**

Full-field concrete longitudinal strain (ϵ_x) along moment region for UHP-FRC#1 at an applied load of 317.7 kips (peak load)

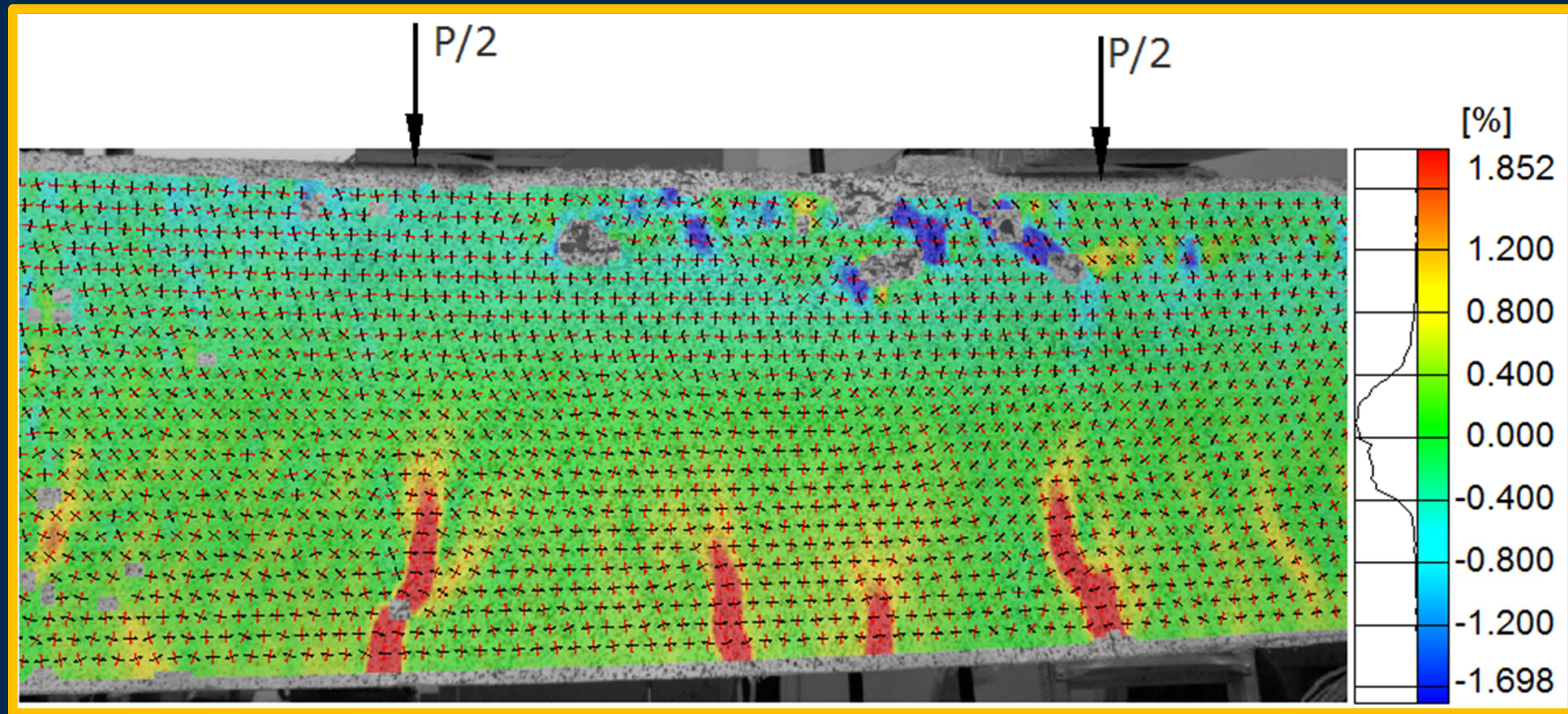

1
3

ϵ_{cu} of Plain Concrete, FRC, and UHP-FRC

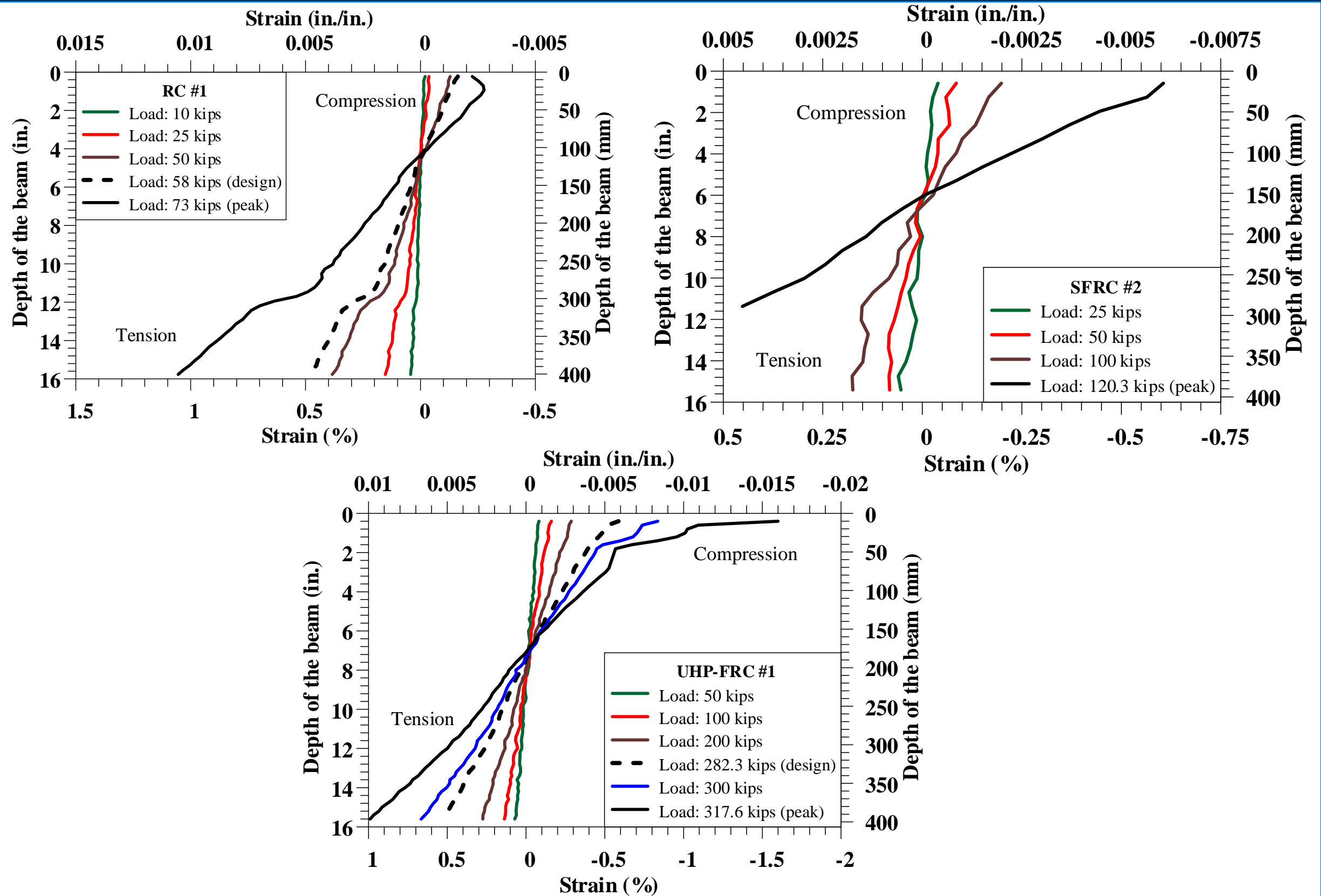

Ultra-High-Performance Fiber-Reinforced Concrete (UHP-FRC): High Compressive Strength & Ductility



Plain concrete

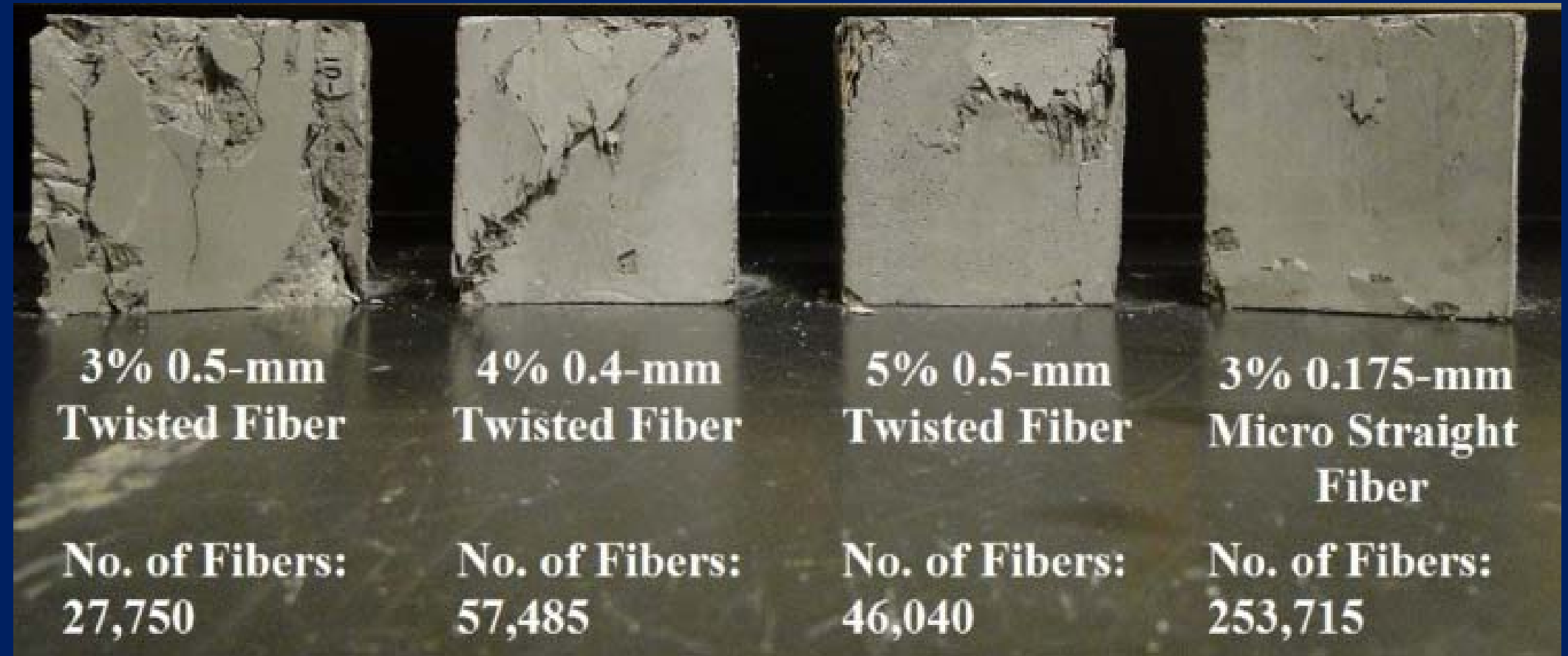

UHP-FRC

Full-scale Column Experimental Results (NSF Award No. 1041633)

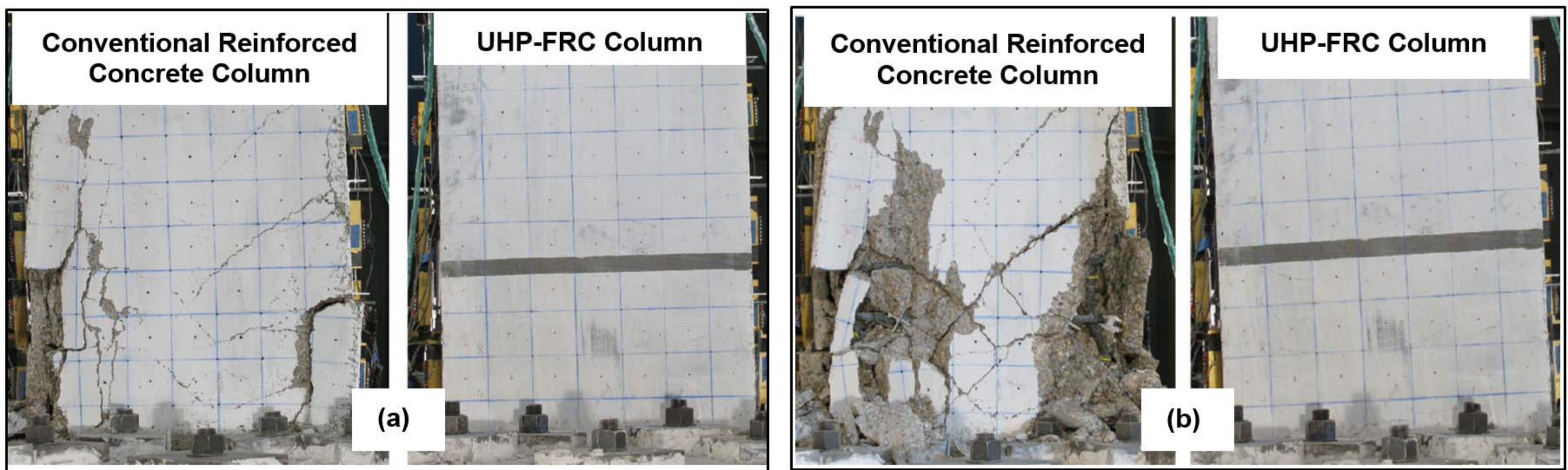

Experimental test results (a) at 2.75% drift ratio and (b) at 5.25% drift ratio (Palacios et al., 2017)

Note: The conventional RC column was designed based on ACI 318-14's seismic provisions.

Effect of UHP-FRC's High Compressive Strain and Strength on A Flexural Member's Curvature Ductility

ϵ_{cu} is approximately 0.015, five times of plain concrete's ϵ_{cu}

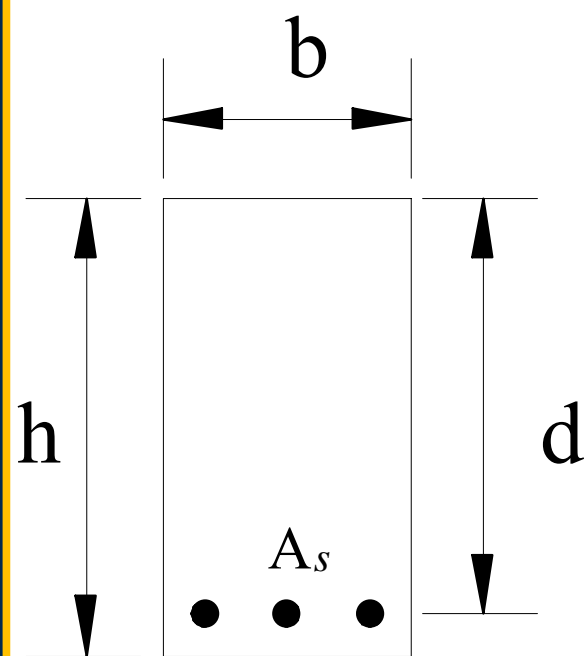

Singly reinforced section

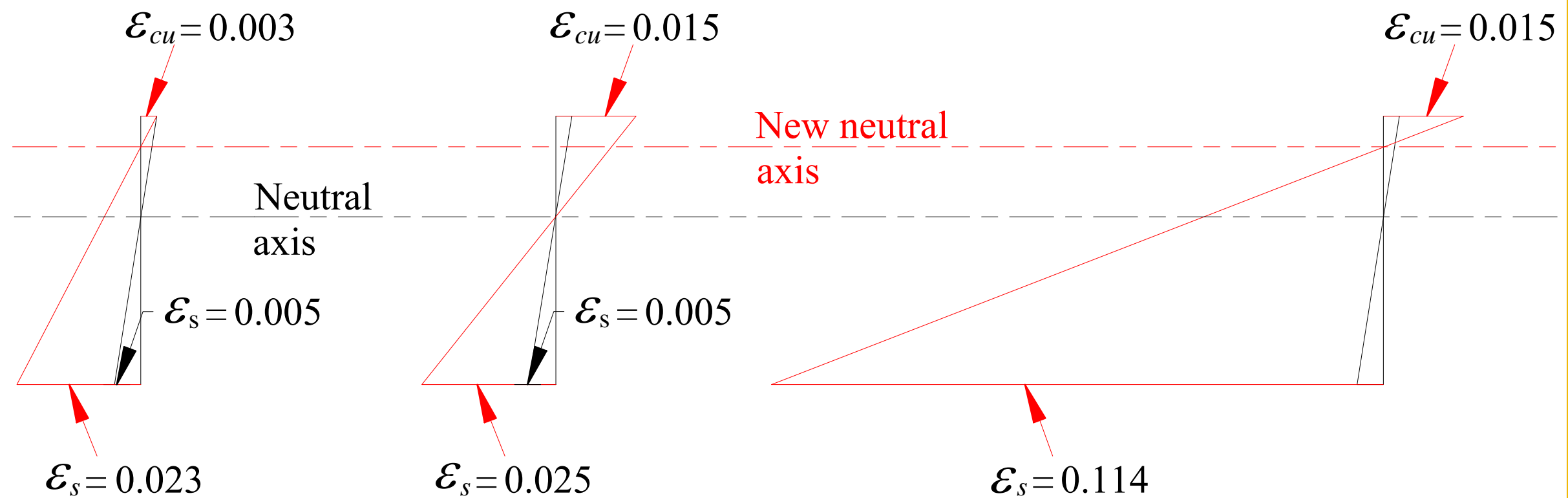

Strain distribution for increased compressive strength

Strain distribution for increased compressive strain

Strain distribution for combined increased compressive strength and strain

New Design Concept : Ductile-Concrete Strong-Reinforcement concept (DCSR design concept)

UHP-FRC (ductile element) + FRP bars (elastic element)



Opposite to conventional RC members

Steel bars (yielding element) + concrete (brittle element, crushed)

Ductile-Concrete Strong-Reinforcement concept (Summary)

- Using high reinforcement ratio of high-strength FRP bars can achieve high structural efficiency (i.e., high flexural strength with a relatively smaller cross-section).
- Keeping rebars elastic can minimize deterioration of bond strength, limit the crack width (thereby maintaining the shear strength and stiffness), and provide restoring force for reducing residual deformation (i.e., self-centering capability).
- The high shear strength of UHP-FRC allows partial or total elimination of shear reinforcement.
- FRP bars + UHP-FRC → a highly durable structural member.

Strain profile and Design Sections

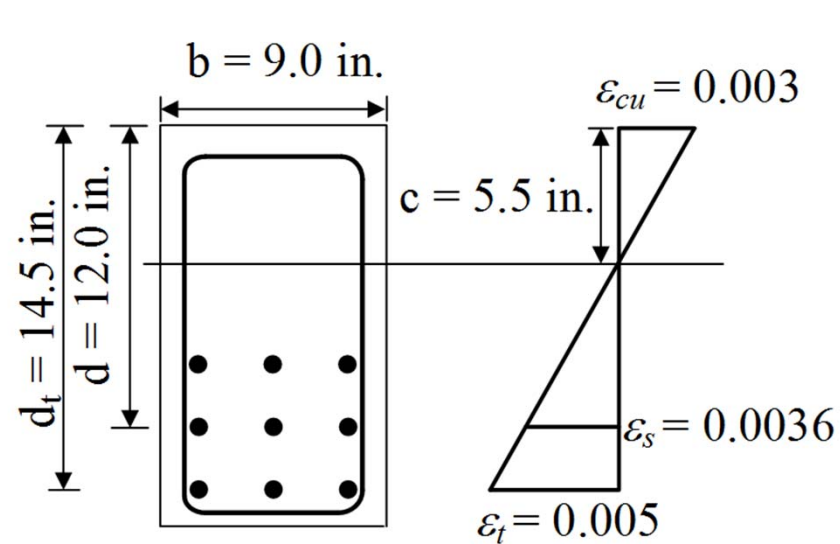

RC #1 (9-#5 Gr. 60 mild steel rebars)

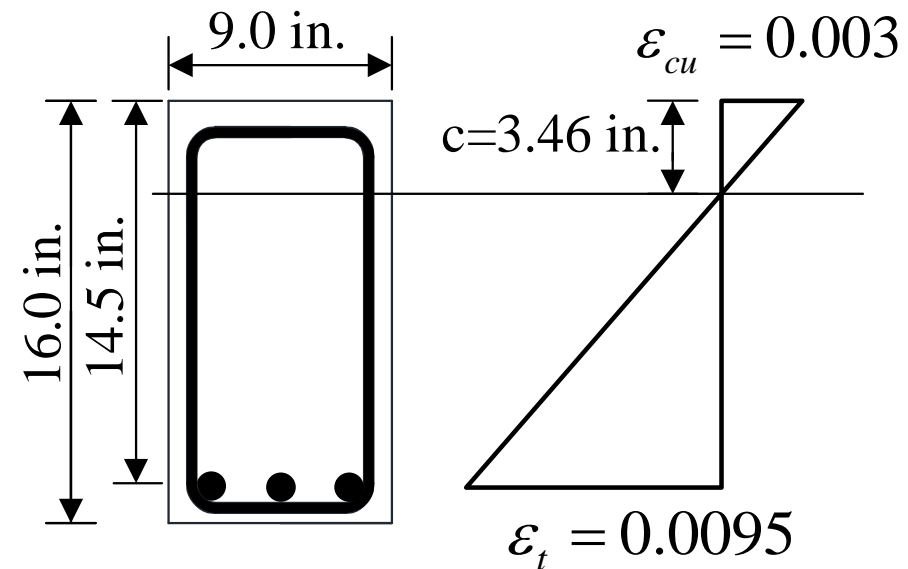

RC #2 (3-#7 BFRP bars)

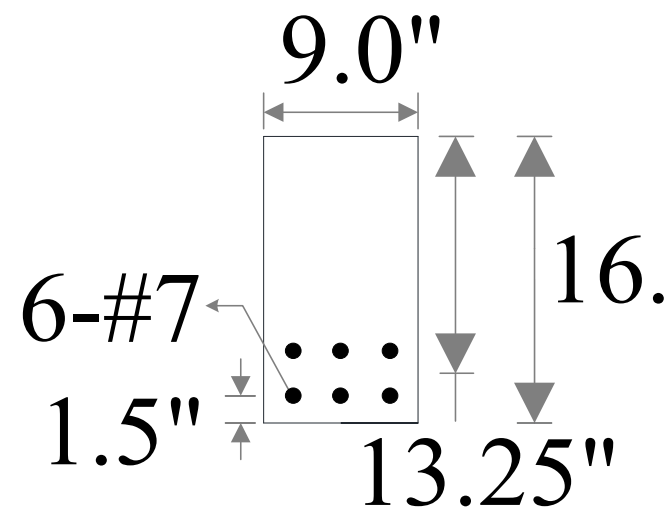

UHP-FRC #4 (6-#7 BFRP bars; no shear reinforcement)

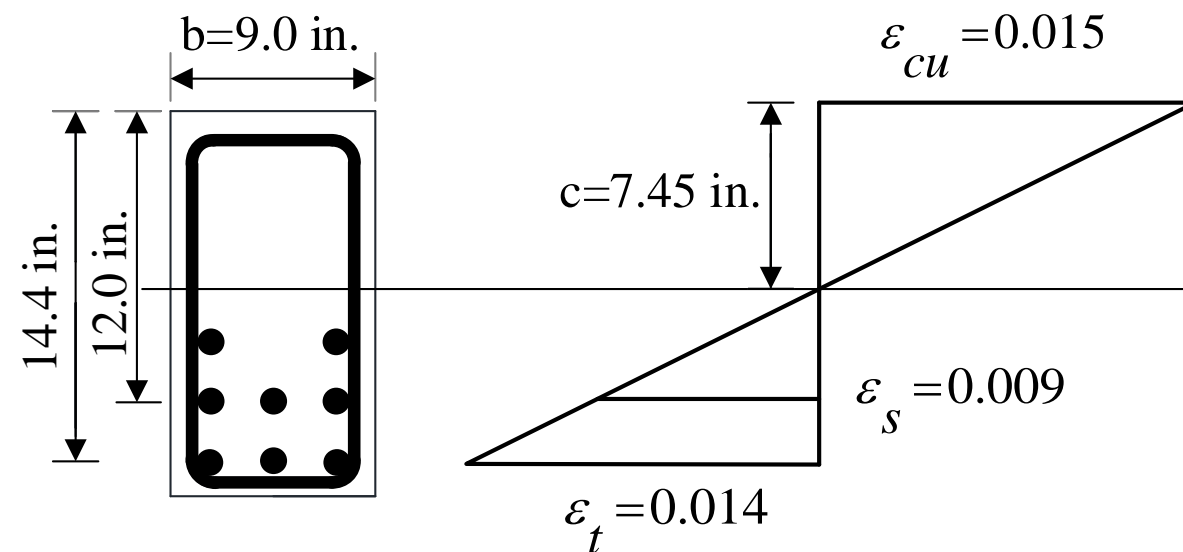

UHP-FRC #5 (8-#8 BFRP bars)

The BFRP (baslt) bars had an ultimate tensile strength of approximately 125 ~ 150 ksi and an ultimate tensile strain of 0.017 to 0.025.

Previous test results : Monotonic Loading

Geometry and reinforcement details

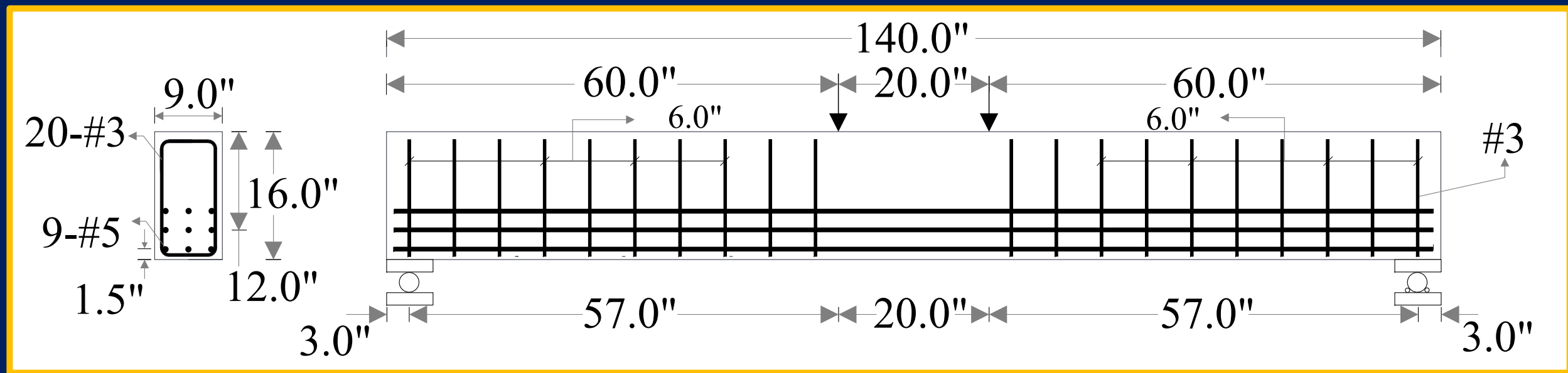

Beam RC #1 (plain concrete + Grade 60 longitudinal rebar)

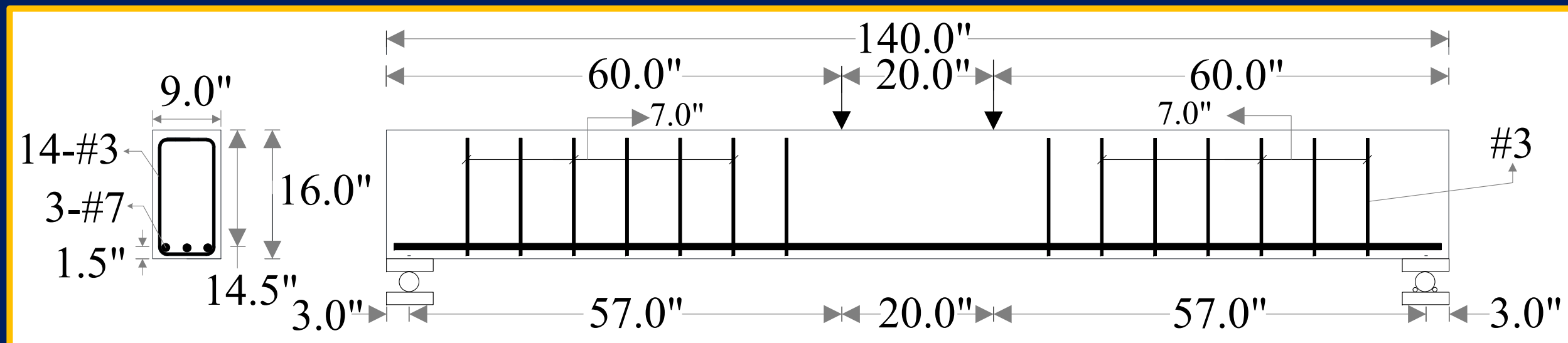

Beam RC #2 (plain concrete + BFRP longitudinal rebar)

Previous test results : Monotonic Loading

Geometry and reinforcement details

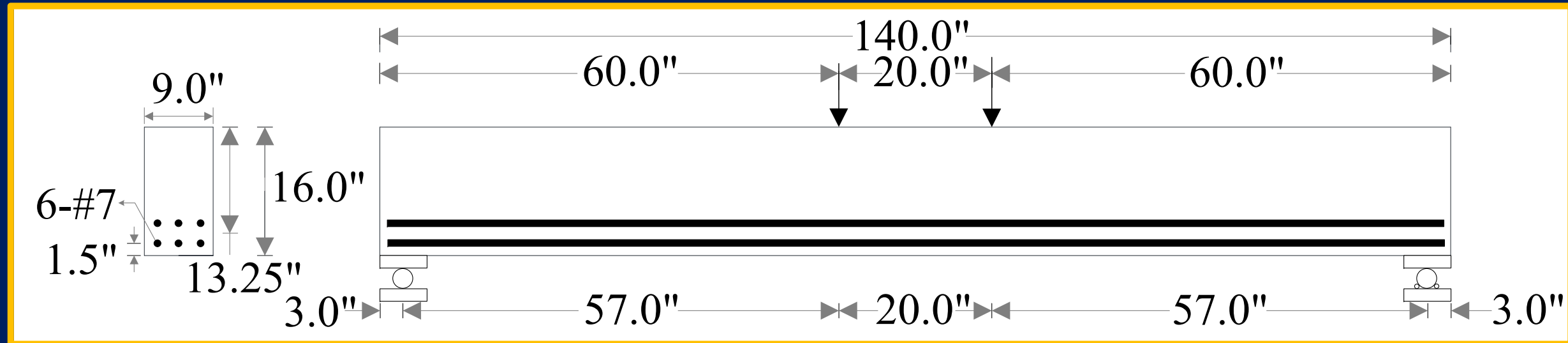

Beam UHP-FRC #4 (BFRP longitudinal rebar)

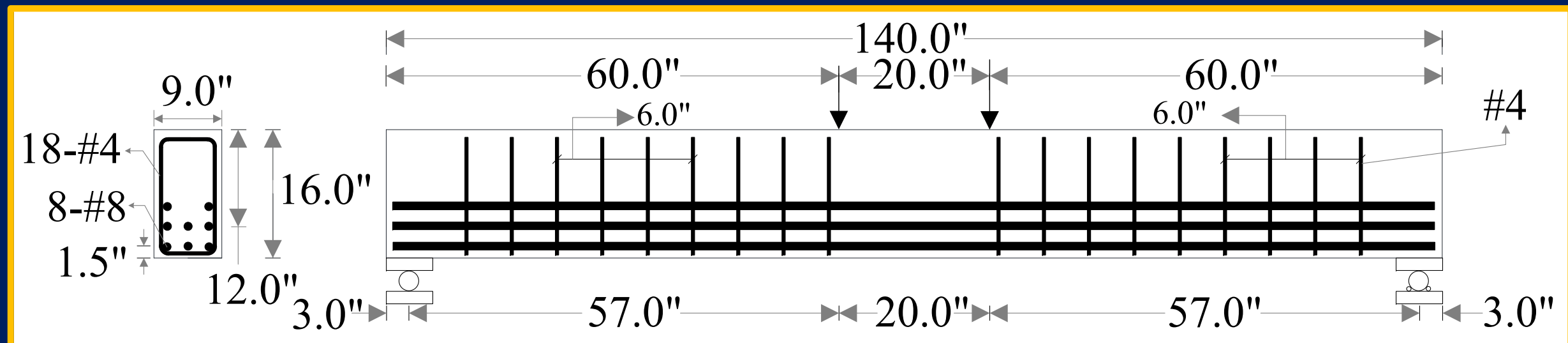

Beam UHP-FRC #5 (BFRP longitudinal rebar)

Load vs Deflection behavior

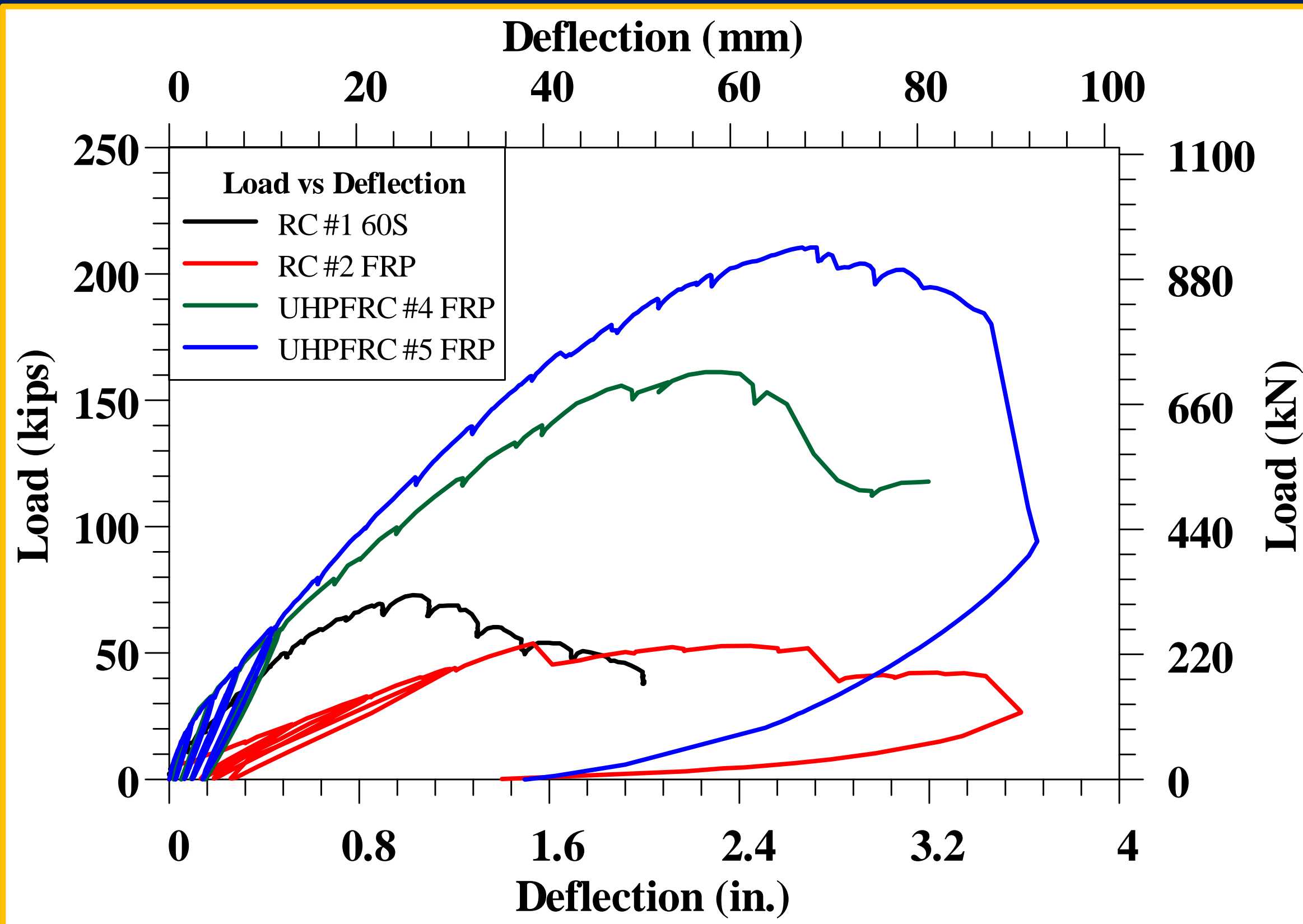

Cracking patterns at the end of test



RC #2 beam (Plain Concrete + BFRP bar)



RC #1 beam (Grade 60 steel)

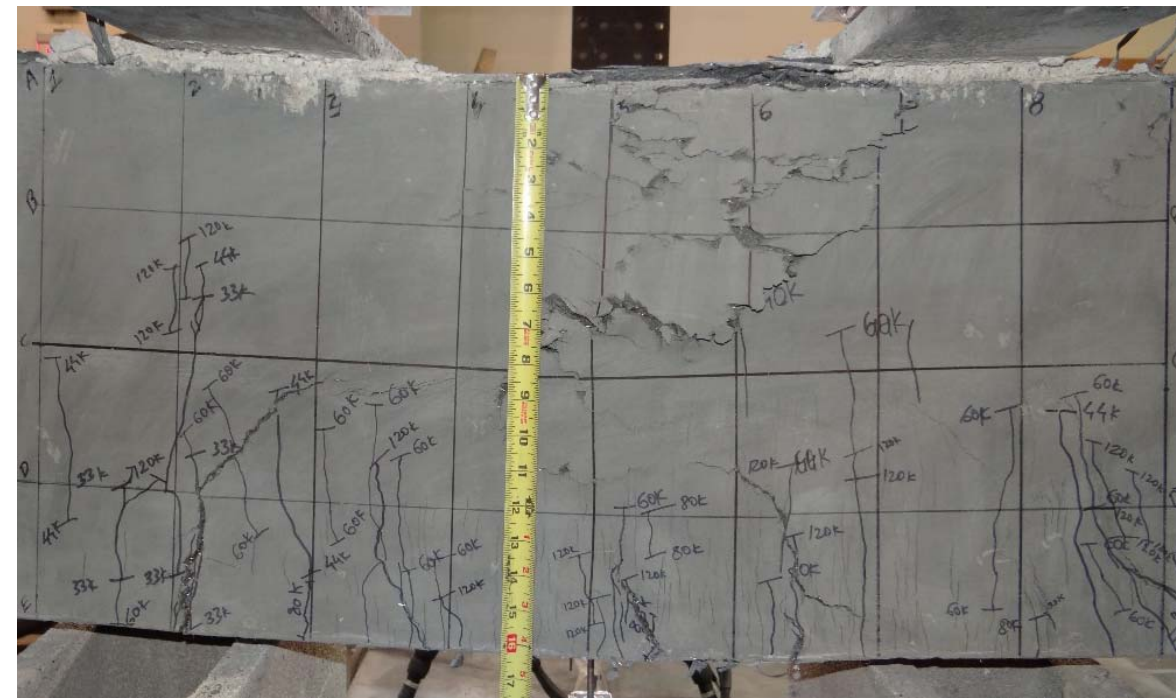

UHP-FRC #5 beam (UHP-FRC+ BFRP bar)

Ductile-Concrete Strong-Reinforcement concept – Cyclic Testing

Design Summary

Specimen	Effective depth (d), in. (mm)	Width of compression face (b), in. (mm)	ρ (%)	Reinforcement type	Fiber type	Effective span, in. (mm)
UHP-FRC #1	4.311 (109)	6 (152)	15.5	MMFX	Steel	49.5 (1257)
UHP-FRC #2	6.375 (162)	6 (152)	13.9	GFRP	Steel	49.5 (1257)
UHP-FRC #3	5.35 (136)	8 (203)	14.8	BFRP	UHMW-PE	34 (864)
UHP-FRC #4	5.35 (136)	8 (203)	14.8	BFRP	Steel	34 (864)

Reinforcement Details

Reinforcement type	Diameter in. (mm)	Tensile strength ksi (MPa)
MMFX (Micro Composite Steel) Grade 100 (ASTM 1035)	1.125 (29)	100 (690)
GFRP (Glass Fiber-Reinforced Polymer)	0.75 (19)	90 (620)
BFRP (Basalt Fiber-Reinforced Polymer)	1.00 (25)	147 (1014)

Ductile-Concrete Strong-Reinforcement concept – Cyclic Testing : Fibers used



	Length (mm)	Diameter (mm)	Tensile Strength (ksi)
Micro Steel Fibers	13	0.12	313
UHMW Polyethylene Fibers	13	0.0015	375

UHP-FRC Beam #3 and #4

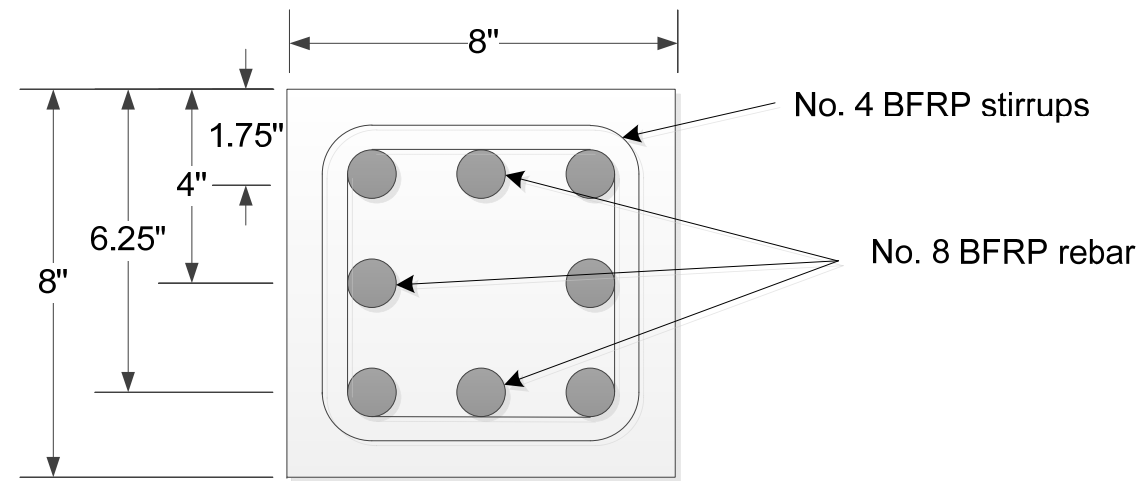

Cross section of beam UHP-FRC #3 and UHP-FRC #4 (BFRP)

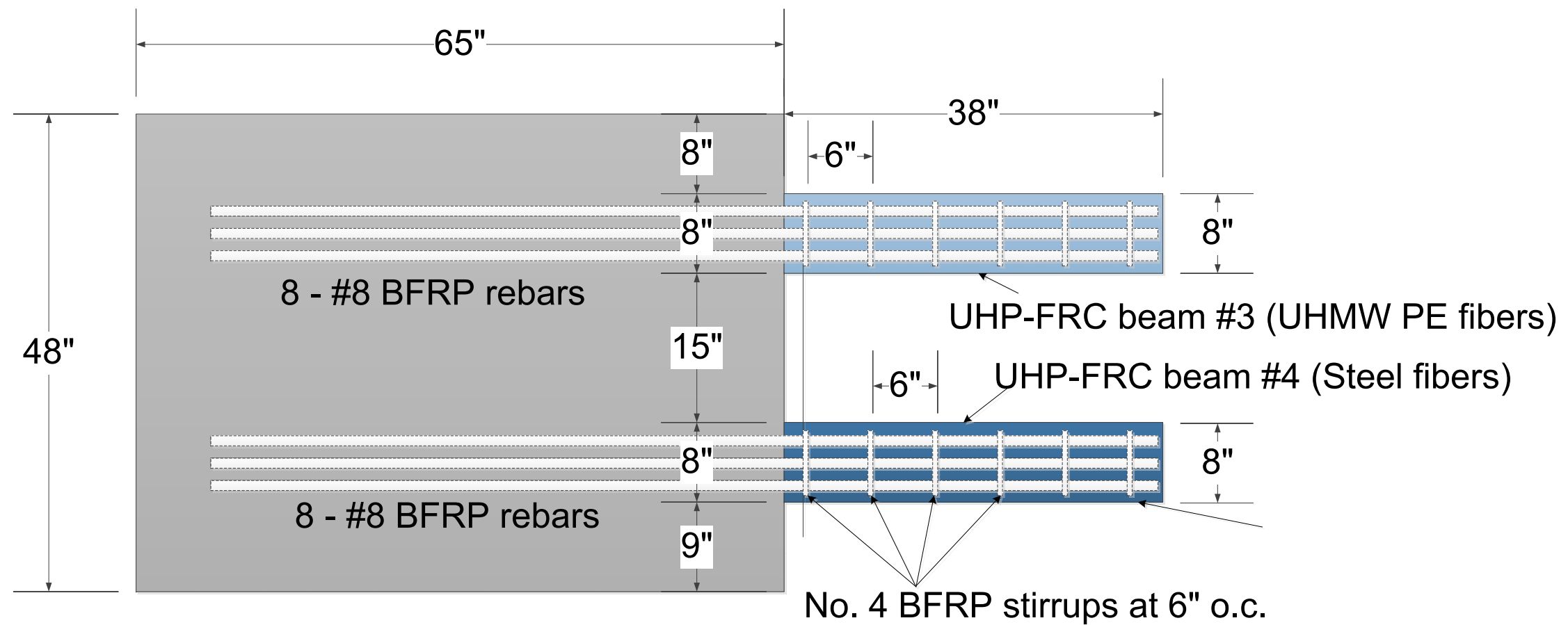

Detailed side view of the specimen showing specimens UHP-FRC #3 and UHP-FRC #4

Loading Protocol

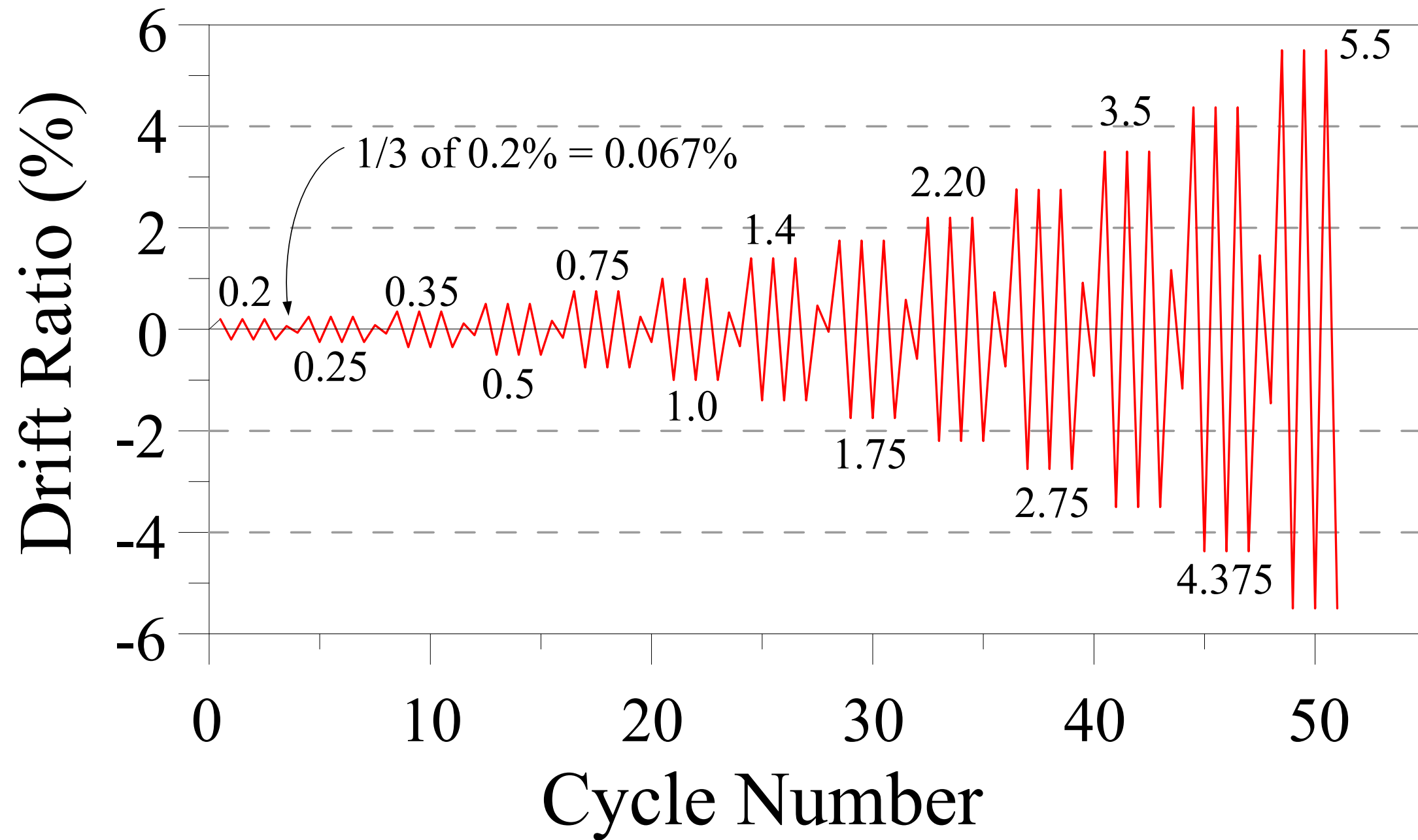

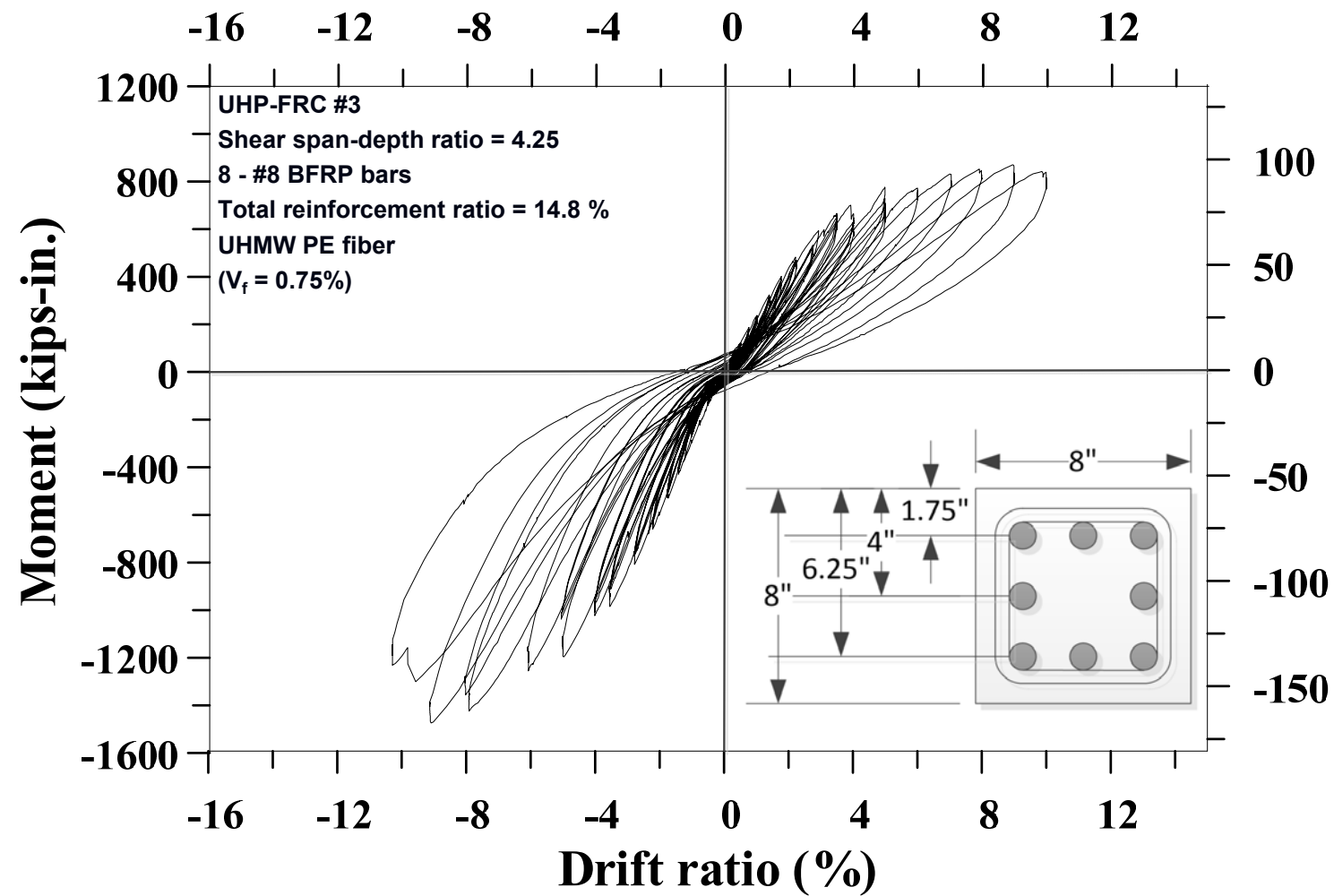

Moment vs Drift ratio for UHP-FRC #3 with UHMW PE fibers (BFRP)

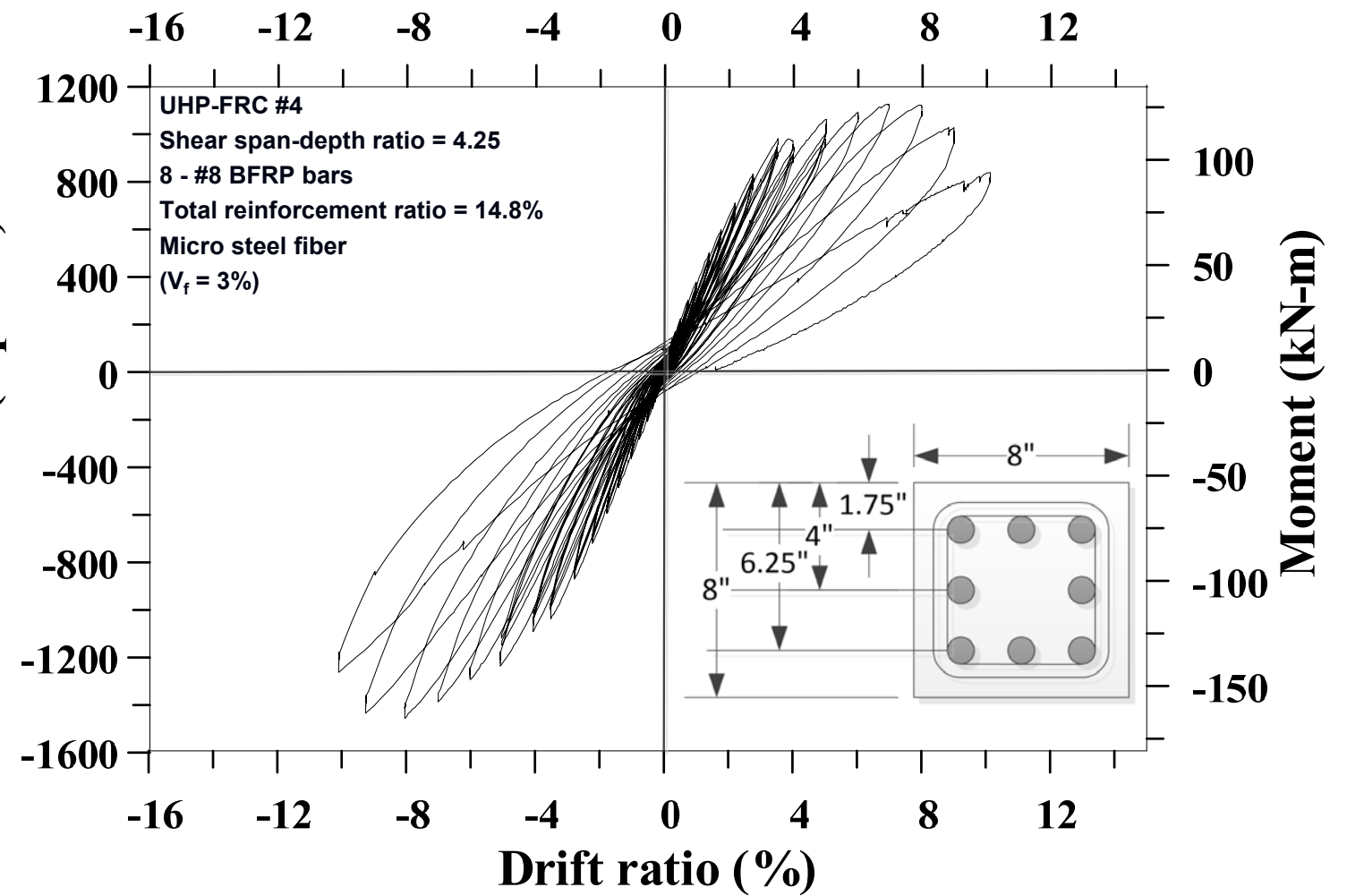

Moment vs Drift ratio for UHP-FRC #4 with steel fibers (BFRP)

BFRP 1% drift ratio (PE)

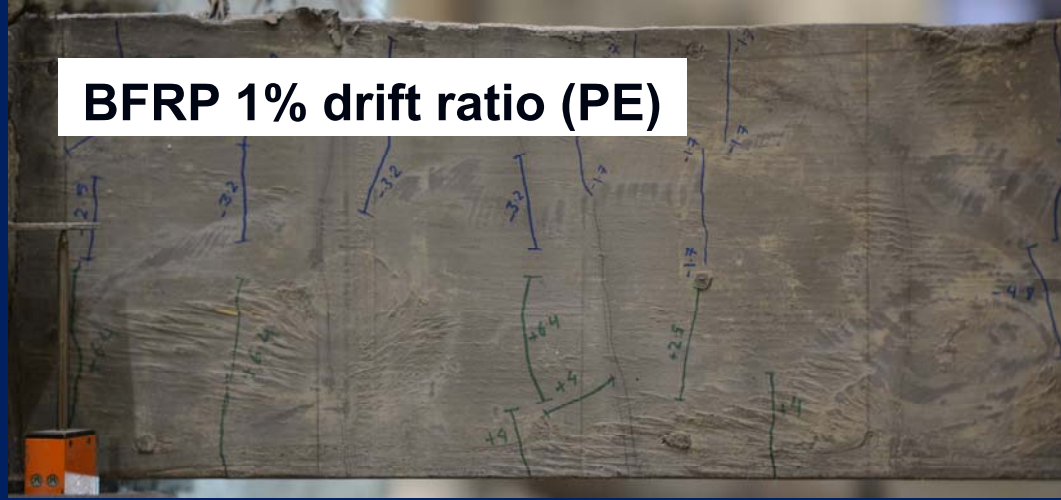

BFRP 1% drift ratio (Steel)



BFRP 3.5% drift ratio (PE)

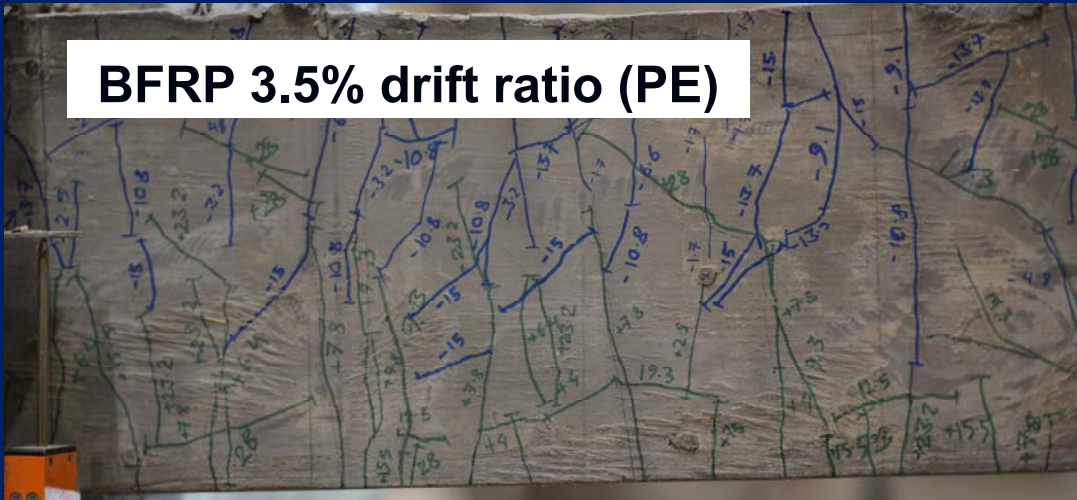

BFRP 3.5% drift ratio (Steel)

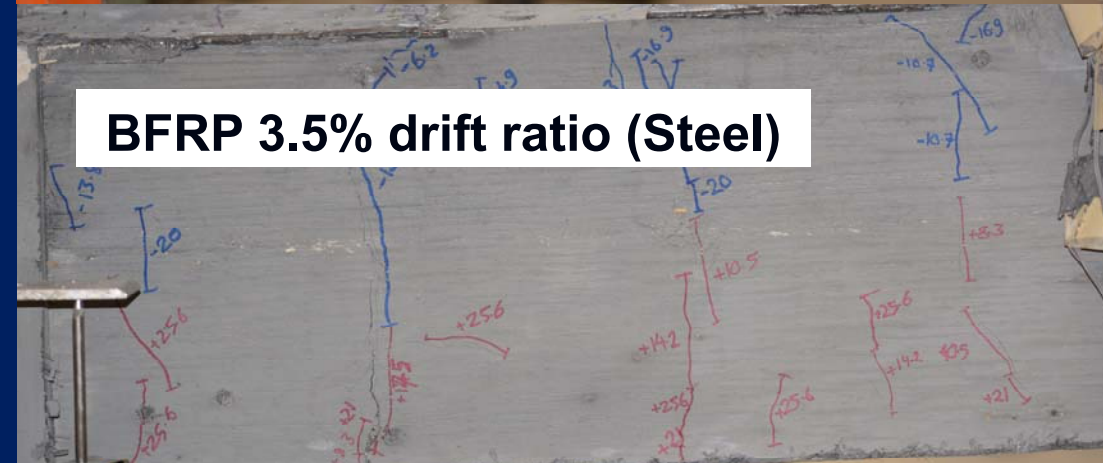

BFRP 5% drift ratio (PE)

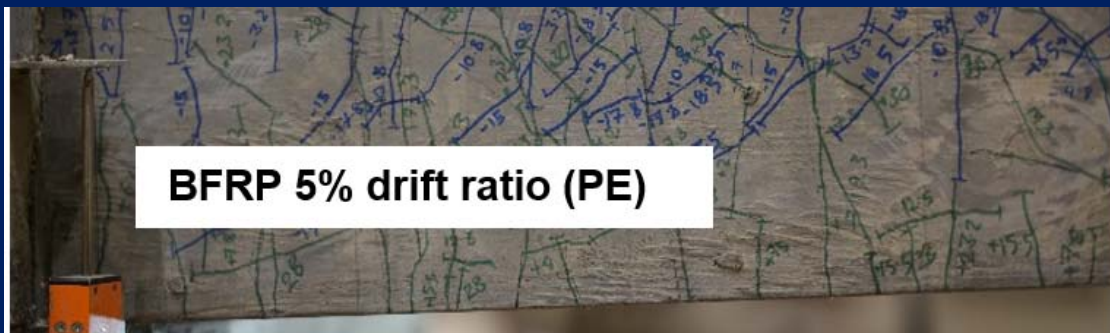

BFRP 5% drift ratio (steel)

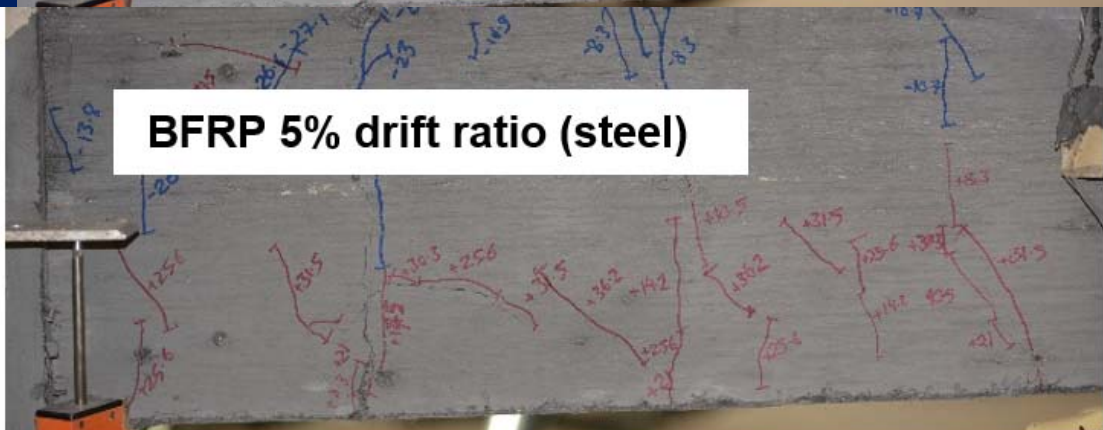

BFRP 10% drift ratio (PE)

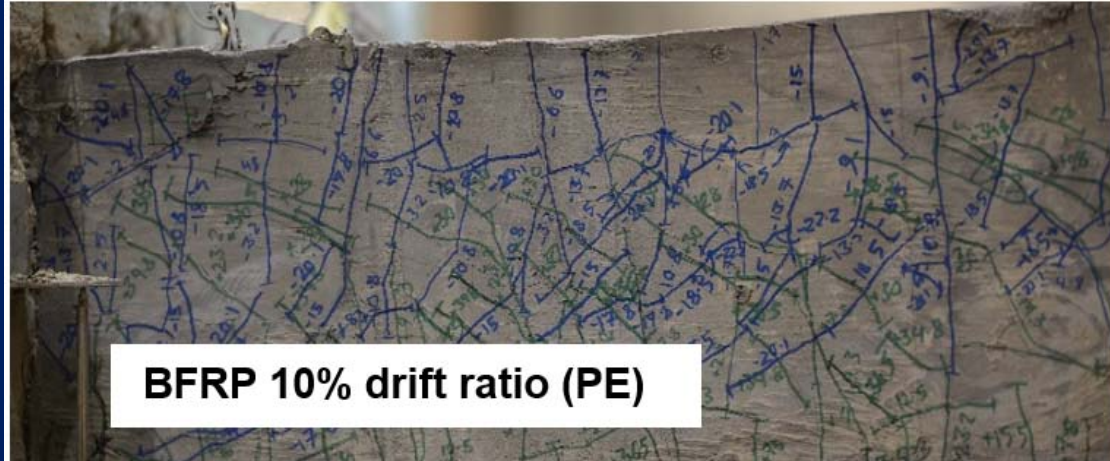

BFRP 9% drift ratio (steel)

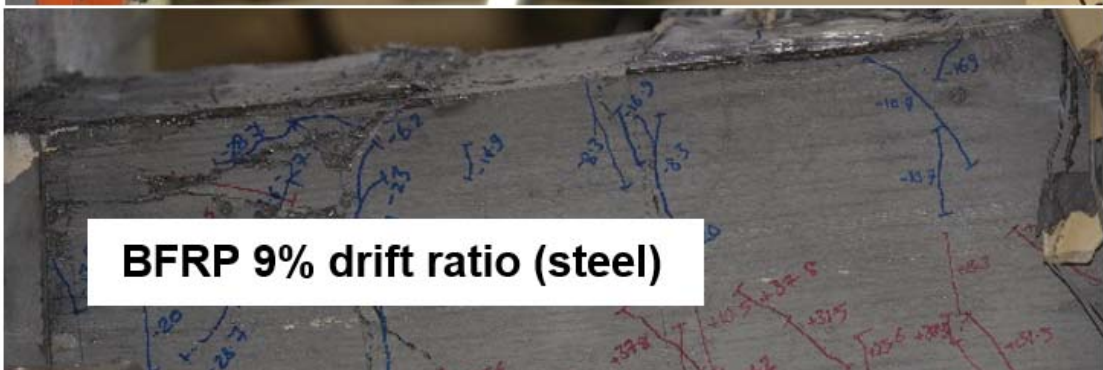

UHP-FRC #3

Shear span-depth ratio = 4.25

8 - #8 BFRP bars

Total reinforcement ratio = 14.8 %

UHMW PE fiber

($V_f = 0.75\%$)

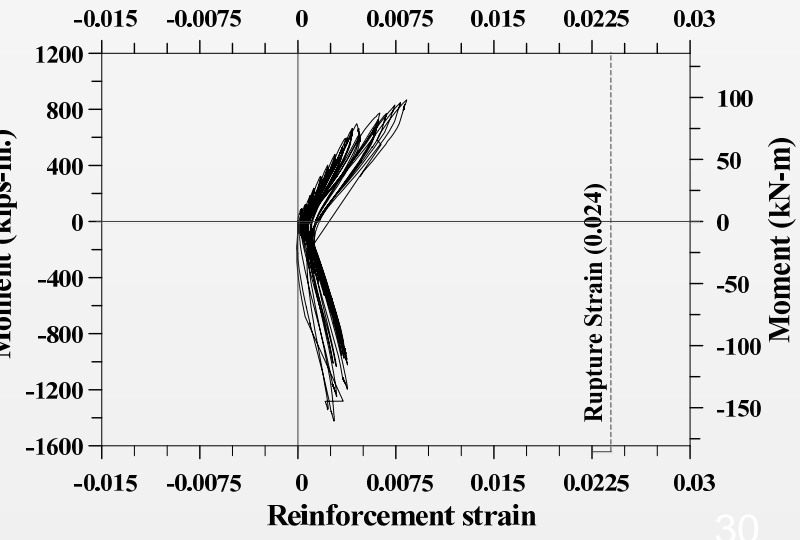
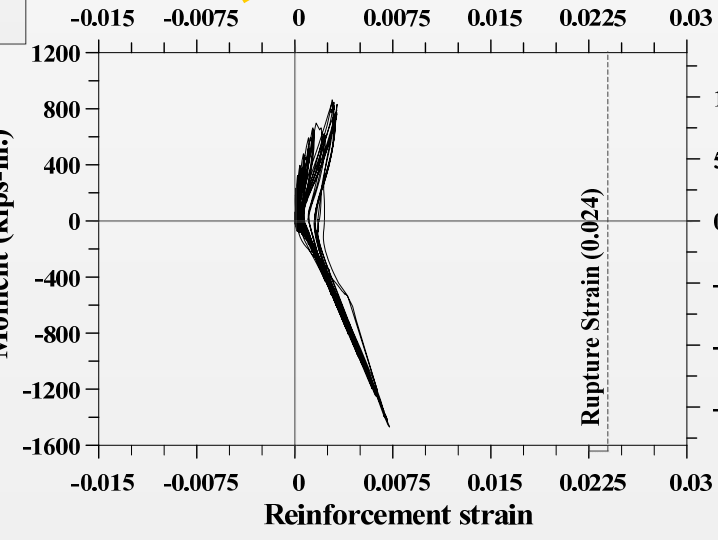
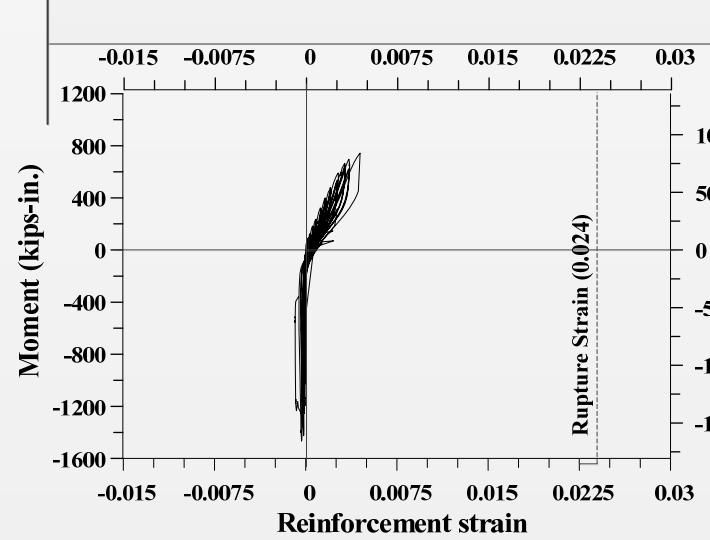
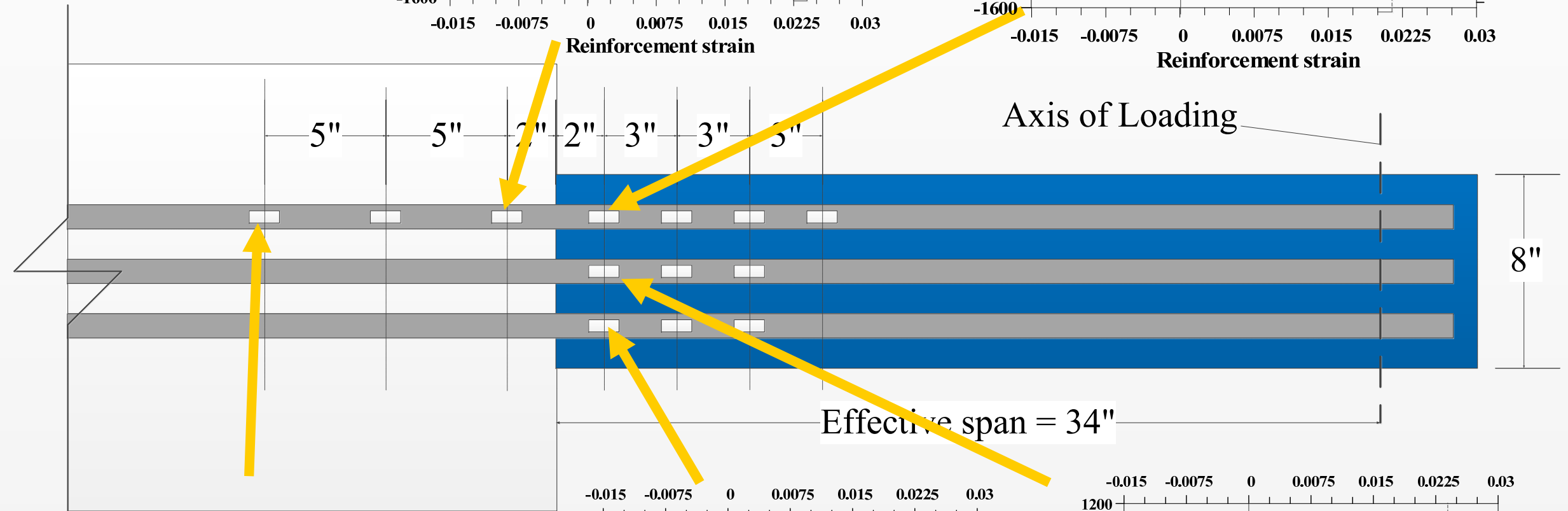
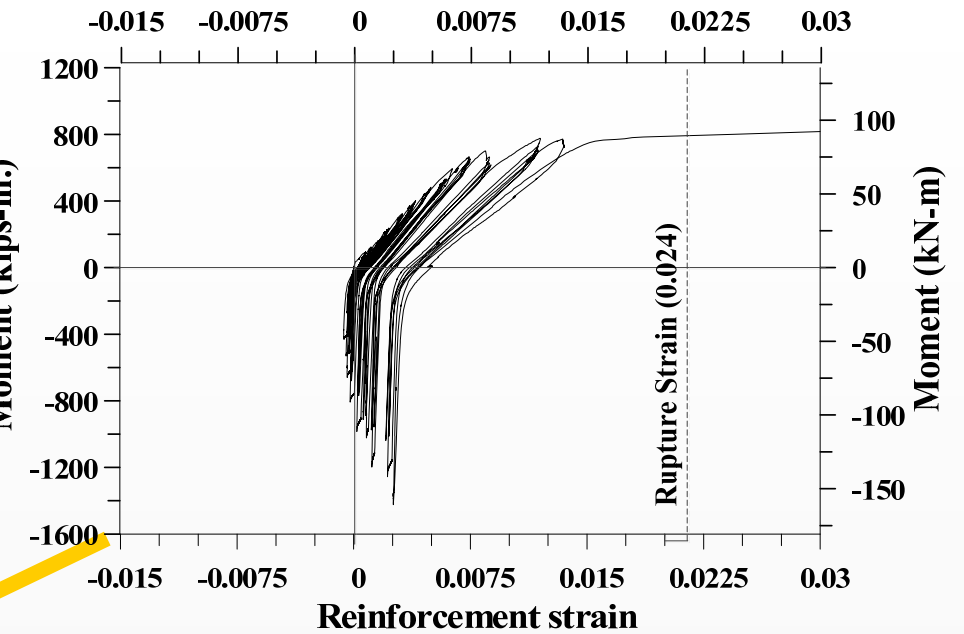
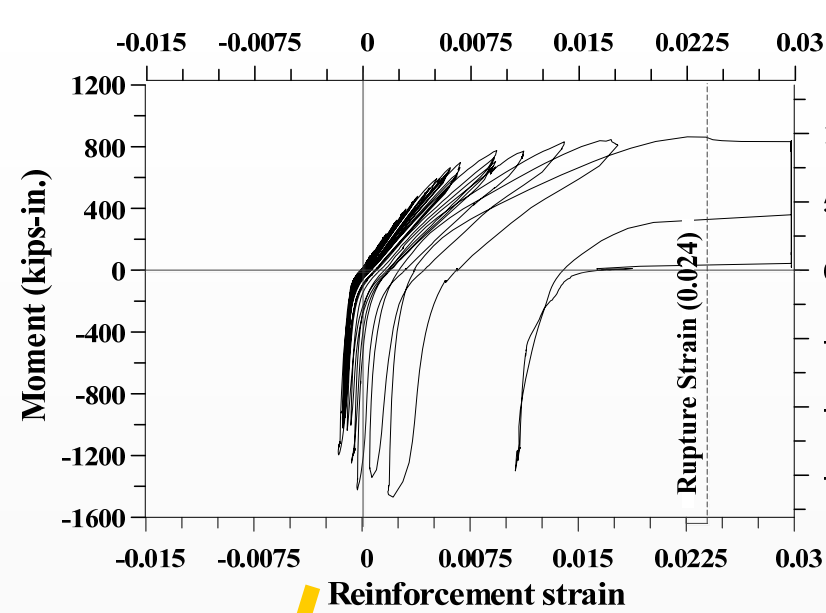

UHP-FRC #4

**Shear span-depth ratio
= 4.25**

8 - #8 BFRP bars

**Total reinforcement
ratio = 14.8 %**

Micro steel fiber

($V_f = 3\%$)

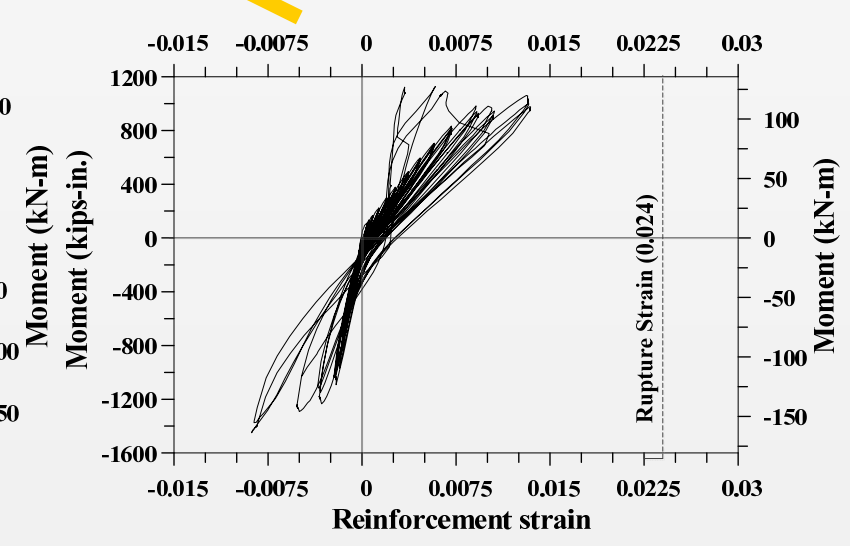
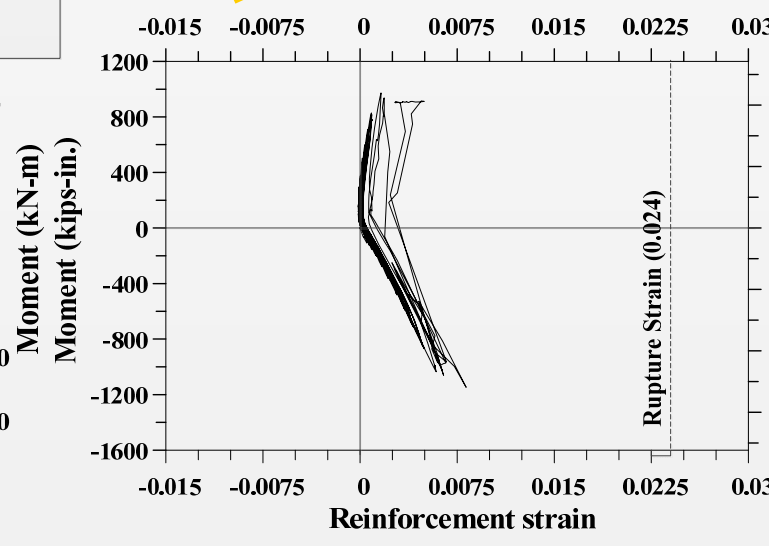
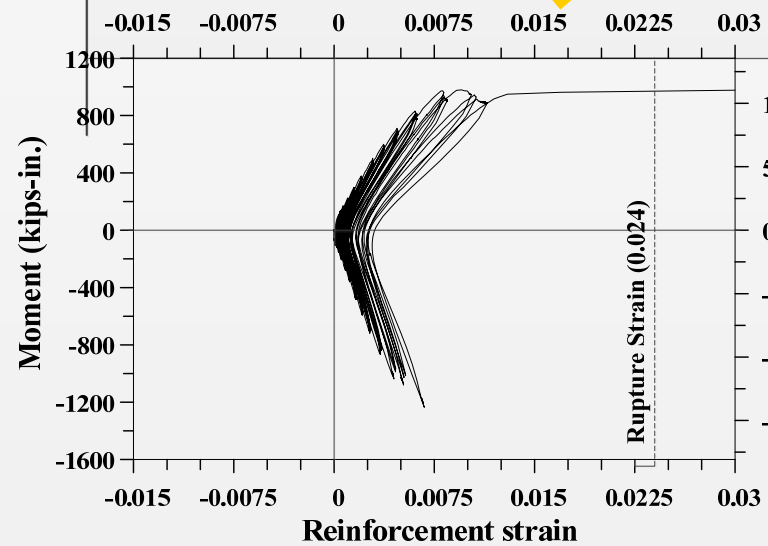
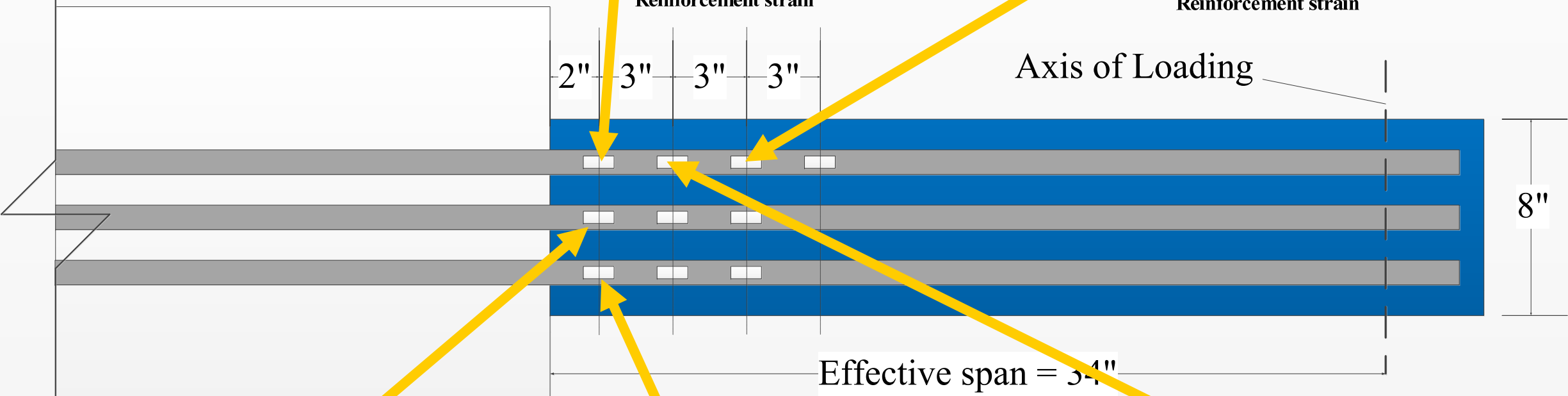
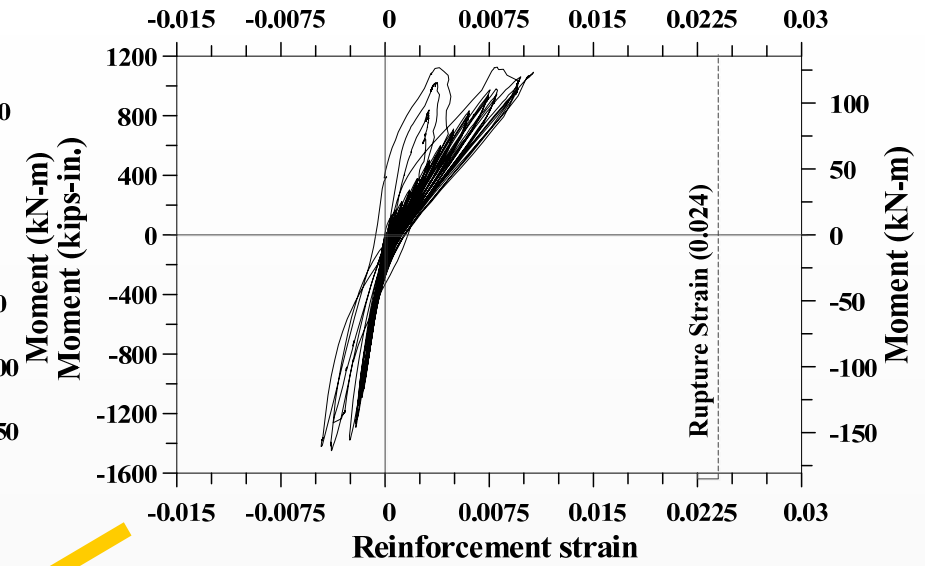
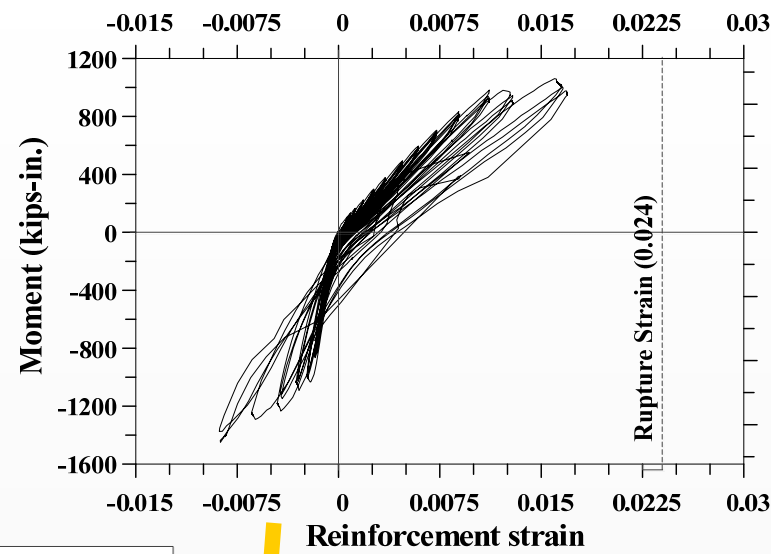

Ultra-high-performance fiber-reinforced concrete (UHP-FRC)

- High compressive strength
- High compressive ductility
- High crack resistance
- High shear strength

Fiber-reinforced polymer (FRP) rebars

- High tensile strength
- Noncorrosive

Structural Members can Simultaneously Achieve All Functions:

- High durability (highly corrosion resistant) → material properties of FRP and UHP-FRC
- High flexural/shear strength → through DCSR design
- High stiffness/→ through DCSR design
- High ductility → through DCSR design (reminder: FRP is a brittle material)
- High resilience (small residual deformation) → through DCSR design