



DIRECT MAIL SOLUTIONS

SE-600-P

Eco-Series

Operation & Parts Manual

12050 49th STREET NORTH - CLEARWATER, FL. 33762-4301

PHONE: 727.571.3330 - FAX: 727.571.3443 - TOLL FREE: 1.800.INSERTER

Pitney Bowes
Direct Mail Solutions

SE 600 PC & PS SERIES

OWNERS MANUAL

Table of Contents

- 1. Set-up instructions**
- 2. Bridge-Tramming Procedure**
- 3. Operation instructions**
- 4. Cleaning**
- 5. Troubleshooting**
- 6. Parts manual**
- 7. Electrical schematic**
- 8. Warranty information**

Pitney Bowes

Direct Mail Solutions

SECTION 1

Pitney Bowes DMS Set-up Instructions

1. Plug the feeder power cord into a 110 VAC grounded outlet.
2. With the feeder ON/OFF switch in the off position, loosen the two side guides and move them all the way to the sides of the feeder. Then loosen the rear guide ramp and move it all the way back out of the way.
3. Place a single piece of the material to be fed on the feeder centering the material relative to the separating device.
4. Move each side guide in to meet the material and then back them off about 1/16".
5. Tighten the bottom thumbscrews on each side guide.
6. If adjustment is required, turn the separator knob clockwise until you can easily pass the single piece of material under the separator. While moving the material back and forth under the separator, turn the separator knob counter-clockwise until you feel resistance from the separator. At this point, you have roughed in the separator setting and will need to tune it in after the completion of the following set-up steps. If the resistance under one separator wheel is not the same as under the separator wheel, the bridge needs to be trammed. See bridge-tramming procedure before proceeding.
7. Place a handful of material in the feeder allowing the material to shingle forward into the separator.
8. Move the back guide forward so as to use the back guide wedge shape to support the back edge of the material stack. At this point, you have roughed in the back guide setting and will need to tune it in later.
9. Add enough material to the stack to fill about half the height of the side guides.
10. Move the top of each side guide out slightly so as to create a funnel effect and then tighten the top adjusting handles on each side guide.

**Pitney Bowes DMS
Set-up Instructions Cont.**

11. You are now ready to feed some material. With the power still off, turn the speed control counter-clockwise to the minimum position.
12. Turn the power switch on and cycle the feeder by holding the red stop button down and pressing green start button. Observe the consistency in which the material is feeding.
13. By turning the separator knob slightly in either direction, you will change the way the material is separating.
14. By moving the back guide in and out, you will quickly find the position that creates the most consistent separation and gap. There must be a gap between pieces when they pass the opposing photo eyes at the discharge of the feeder. If there is no gap, the feeder will not count pieces correctly.
15. One important item to note; There is no substitution for experience. By working with the feeder, you will notice that the combination of separator setting and the back guide adjustment together will have the greatest effect on separation. Generally, the longer the piece of material, the flatter the material stack should be. Conversely, the shorter the piece of material, the closer the back guide adjustment should be to the material, adding wedge to the material stack. You will also notice that by moving the back guide forward (increasing the wedge), you can open the separator and still achieve good separation.

Pitney Bowes DMS Bridge-Tramming Procedure

Normally this is a factory setting that does not require adjustment. However, raising the bridge may be required to run thick material and this adjustment may be required. This setting is critical to the performance of the feeder. This will ensure that the separator wheels are level with respect to the nip rollers. To do this, first loosen the bridge mounting screws (Item 7, Fig. 6-3) on both sides of the bridge. Turn the separator adjustment CCW until the separator wheels are in their lowest position. Now place a thin strip of paper under each separator wheel (it is best to cut one piece of paper into two strips to ensure that the strips are the same thickness). Tighten one screw on each side. Move the paper strips to feel if the resistance is equal under each separator wheel. If one moves with less resistance than the other, loosen the screw on the side that is tighter and raise that side of the bridge slightly and tighten screw. Check the resistance under each separator wheel with the paper strips again and adjust accordingly. This procedure must be followed whenever the bridge is adjusted up or down for materials with different thickness. This adjustment is **“very”** critical when feeding thin materials.

Pitney Bowes DMS Operation Instructions

BATCH COUNTING

- Your Pitney Bowes DMS feeder is equipped with a batch counter. The batch value is pre-set from the factory with a value of 1. To change the batch value, first locate the batch controller on the rear of the feeder. Press the button labeled (P2) once to activate the setting mode. Now by pressing any of the buttons you can change the corresponding digit in the desired batch value. By pressing the P1 button you can change the 0 to 9 values. By pressing the P2 button you can change the 10 to 90 values. P3 changes the 100 to 900 values and so forth. As you change each digit of the value, you will see the LED display change accordingly. When you have displayed the desired batch value press the ENTER button (E) followed by the reset button (R). You are now ready to batch the desired number of pieces. (Note: You must press ENTER followed by RESET or changes will not be saved.) The new value will be stored until a different value is properly set even when the power is turned off to the feeder.
- Another feature associated with your batch counter is a deceleration phase at the end of the batch. . Press the button labeled (P1) once to activate the setting mode. Now by pressing the (P1) button again you can adjust the number of pieces that the feeder decelerates for. For example, if the setting is (1) the feeder slows down during the last piece in the batch. The value of 1 is normally the best setting, however if the feeder is running slow a value of (0) may work better. However, if the feeder is running fast, a deceleration value of (0) may not stop the feeder quick enough. You can extend the life of the feeder by maintaining a deceleration (P1) value of (1) or (2).

Pitney Bowes DMS
Operation Instructions

MANUAL OPERATION

- There are (2) recessed buttons on the back of the feeder. The red button is the Stop / Reset button. The green button will start the feeder manually. Press the green button and the feeder will feed a batch pre-determined by the batch counter. Hold the red button down and press the green button and the feeder will feed a single piece.

ERRORS

- There is a red LED near the manual push buttons. The feeder will stop and This LED will light up or flash if an error has occurred. The LED will flash for a missing piece, out of paper, and excessive batch time. The LED will remain lit for a paper jam.

Pitney Bowes

Direct Mail Solutions

SECTION 4

Pitney Bowes DMS Cleaning Instructions

Clean rollers and belts are very important to the performance of the feeder. Use a clean rag dampened with Isopropyl Rubbing alcohol, 70% by volume (typically available in drug stores) to clean belts and rollers. Do not use any other solvents, cleaners, or abrasive cleaners on the rollers or belts as they may damage the rubber.

Warning: Isopropyl rubbing alcohol is very flammable! Always unplug the machine before cleaning belts and rollers. DO NOT! use near an open flame, sparks, or any other source of ignition. DO NOT! smoke in the vicinity of the alcohol fumes. Allow used rags to air-dry before throwing them in the trash. Dispose of used rags properly.

Other areas of the machine should be wiped clean with a clean dry rag.

**Pitney Bowes DMS
Troubleshooting Guide**

<u>Problem</u>	<u>Solution</u>
Feeder will not run.	Check circuit breaker condition. Check outlet power source. Check power switch.
Feeder runs but no material is being dispensed.	Check material supply. Remove all material and follow setup procedure. Check rollers and belts for excessive wear or dirt.
Feeder does not create a gap between pieces.	Lower separator adjustment and observe. If a gap is not present after this adjustment, return separator to original position and move the back guide forward.
Feeder does not detect material.	Adjust position of the sensor.
Thick material does not feed well.	Decrease the height at the back of the material stack. Increase the opening at the separation device (the thicker the material the less critical the setting is).

**Pitney Bowes DMS
Troubleshooting Guide Cont.**

<u>Problem</u>	<u>Solution</u>
Thin material does not feed.	Adjust separation device as described in section 2. Remove material and fan the stack allowing air to separate the pieces. Raise the rear of the material stack by moving the wedge forward.
Material feeds double.	After confirming set up is correct, inspect the o-rings. If the o-rings are worn past the shoulder of the separator wheel, they will not be effective. Replace the o-rings and reset the gap.

Pitney Bowes
Direct Mail Solutions

SECTION 6

Pitney Bowes DMS
Parts Manual

Pitney Bowes
Direct Mail Solutions

SECTION 6

FEEDER ASSEMBLY (FIG. 6-1)

ITEM	PART NO.	QTY.	DESCRIPTION
1	99000-001	1	BELT, TIMING 90XL
2	99000-041	1	BELT, TIMING 100XL
3	99000-003	1	BELT, TIMING 120XL
4	99000-004	3	BELT, RED GUM
5	SEE FIG. 6-2	1	SEPERATOR ASSEMBLY (ECO)
6	SEE FIG. 6-3	1	SIDE GUIDE ASSEMBLY
7	SEE FIG. 6-4	1	FRONT SHAFT ASSEMBLY
8	SEE FIG. 6-4	1	SUPPORT SHAFT ASSEMBLY
9	SEE FIG. 6-4	1	SUPPORT IDLER SHAFT ASSEMBLY
10	SEE FIG. 6-4	1	MAIN SHAFT ASSEMBLY
11	SEE FIG. 6-5	1	CLUTCH SHAFT ASSEMBLY
12	SEE FIG. 6-6	1	MOTOR ASSEMBLY
13	SEE FIG. 6-5	1	PAPER SLIDE ASSEMBLY
14	SEE FIG. 6-7	1	CHASSIS ASSEMBLY
15	SEE FIG. 6-8	1	ELECTRICAL COMPONENT ASSEMBLY
16	SEE FIG. 6-9	1	TRAILING ARM ASSEMBLY
17	SEE FIG. 6-10	1	ACCELERATOR ASSEMBLY

Pitney Bowes Direct Mail Solutions

SECTION 6

FIG. 6-1

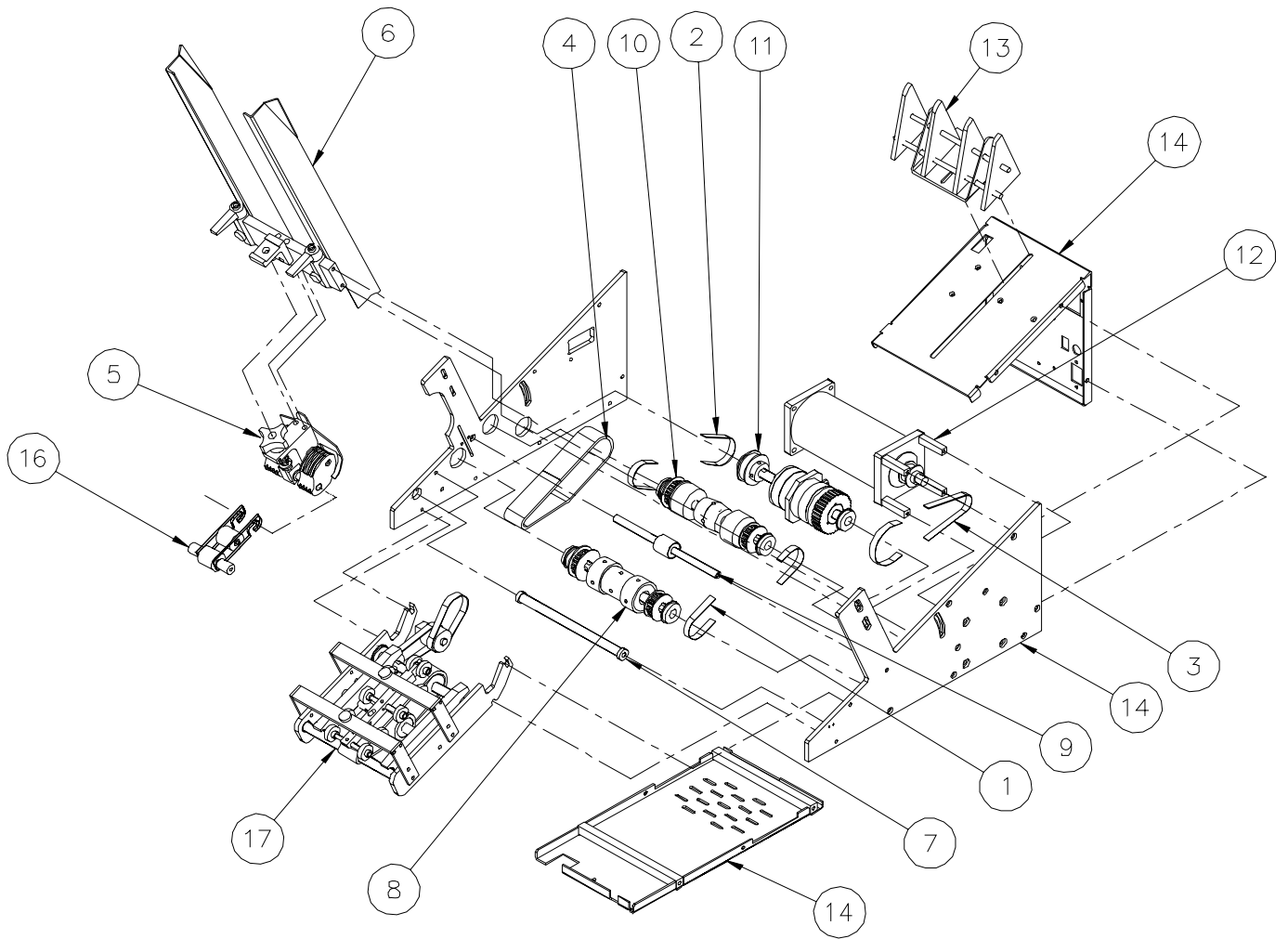

Pitney Bowes
Direct Mail Solutions

SECTION 6

SEPARATOR ASSEMBLY (ECO) (Fig. 6-2)

ITEM	PART NO.	QTY.	DESCRIPTION
1	10007-002	1	BLOCK, FOOTBALL SEPARATOR
2	10004-059	1	SHAFT, FOOTBALL ALIGNING
3	10004-058	1	SHAFT, FOOTBALL SEPARATOR
4	10005-025	1	SHROUD, SEPARATOR
5	10007-005	2	BLOCK, FOOTBALL.
6	10007-012	1	BLOCK, SEPARATOR ADJUSTING
7	10004-028	1	STUD, SEPARATOR ADJUSTING
8	99004-001	1	KNOB 5/16-24 FE
9	10014-010	8	O-RINGS, FOOTBALL SEPARATOR
10	10019-002	1	SPRING, COMPRESSION (FOOTBALL)
11	10012-005	2	SPACER, FOOTBALL SEPERATOR
12		1	NUT, HEX 5/16-24
13		2	WASHER, FLAT 5/16
14		2	SCREW, PAN HD 10-24 X 3/8
15		3	SCREW, FL HD 8-32 X 1
16		2	WASHER, FLAT, #10
17	99003-017	2	WASHER, NYLON 3/8 ID X 1/16
18	99022-003	2	SNAP RING, 3/8
19		2	BOLT, SOCKET HD, 5/16-18 X 2 1/2
20	99003-015	1	WASHER, NYLON, 5/16 X 1/16

Pitney Bowes
Direct Mail Solutions

SECTION 6

FIG 6-2

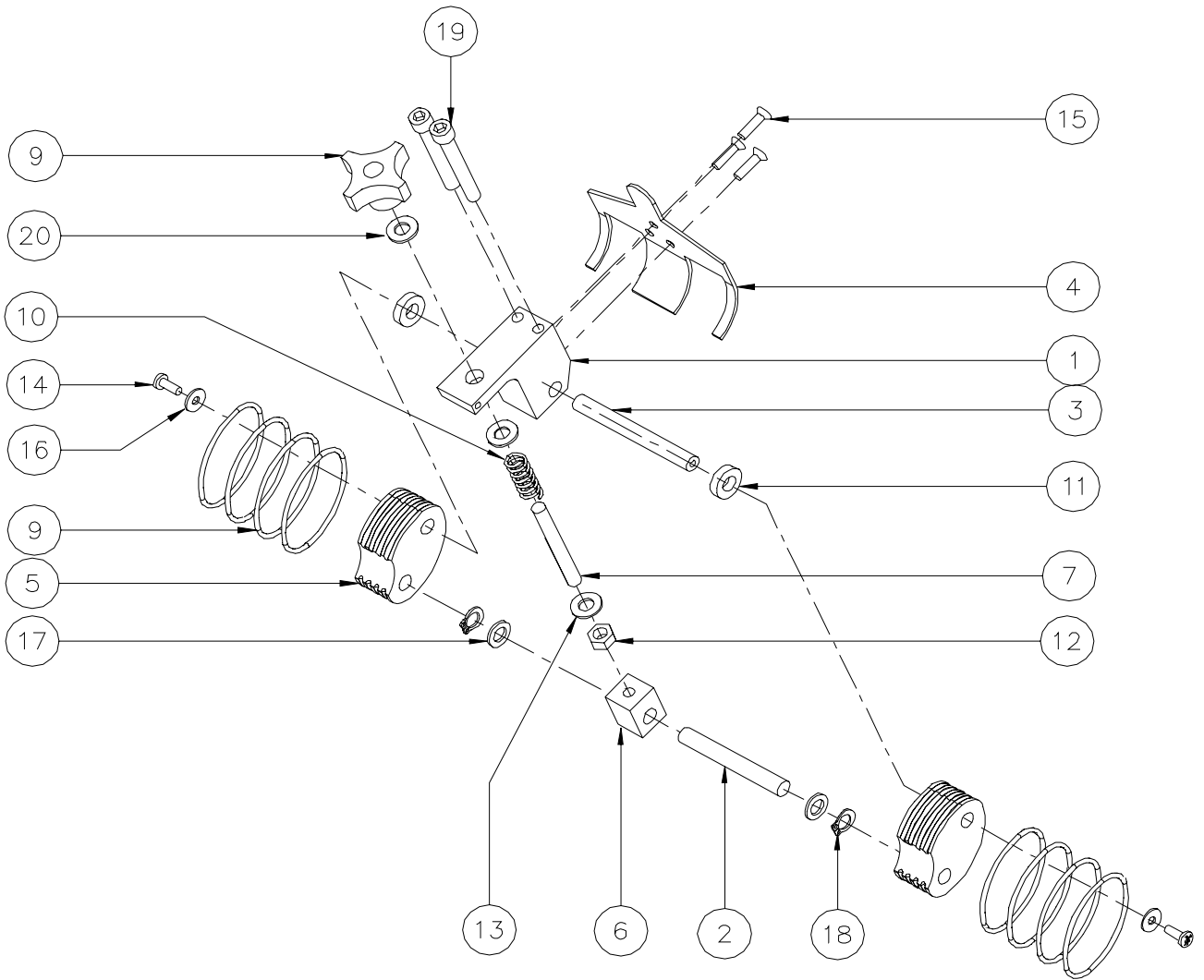

Pitney Bowes
Direct Mail Solutions

SECTION 6

SIDE GUIDE ASSEMBLY (Fig. 6-3)

ITEM	PART NO.	QTY.	DESCRIPTION
1	10009-002	2	BRACKET, SIDE GUIDE MTG
2	10003-006	1	CROSS BAR, SE-600-P
3	10005-009	1	GUIDE, SIDE, RH (TALL)
4	10005-008	1	GUIDE, SIDE, LH (TALL)
5	99004-002	2	KNOB, #10 SCREW
6		4	SCREW, SKT HD, 10-24 X 1/2
7		4	SCREW, BTN HD, 10-24 X 1/2
8		4	SCREW, FLAT HD, 6-32 X 1/2
9	10007-010	1	BLOCK, SEPARATOR ADJ
10	99004-003	2	HANDLE, RATCHET, 10-24

Pitney Bowes
Direct Mail Solutions

SECTION 6

FIG. 3

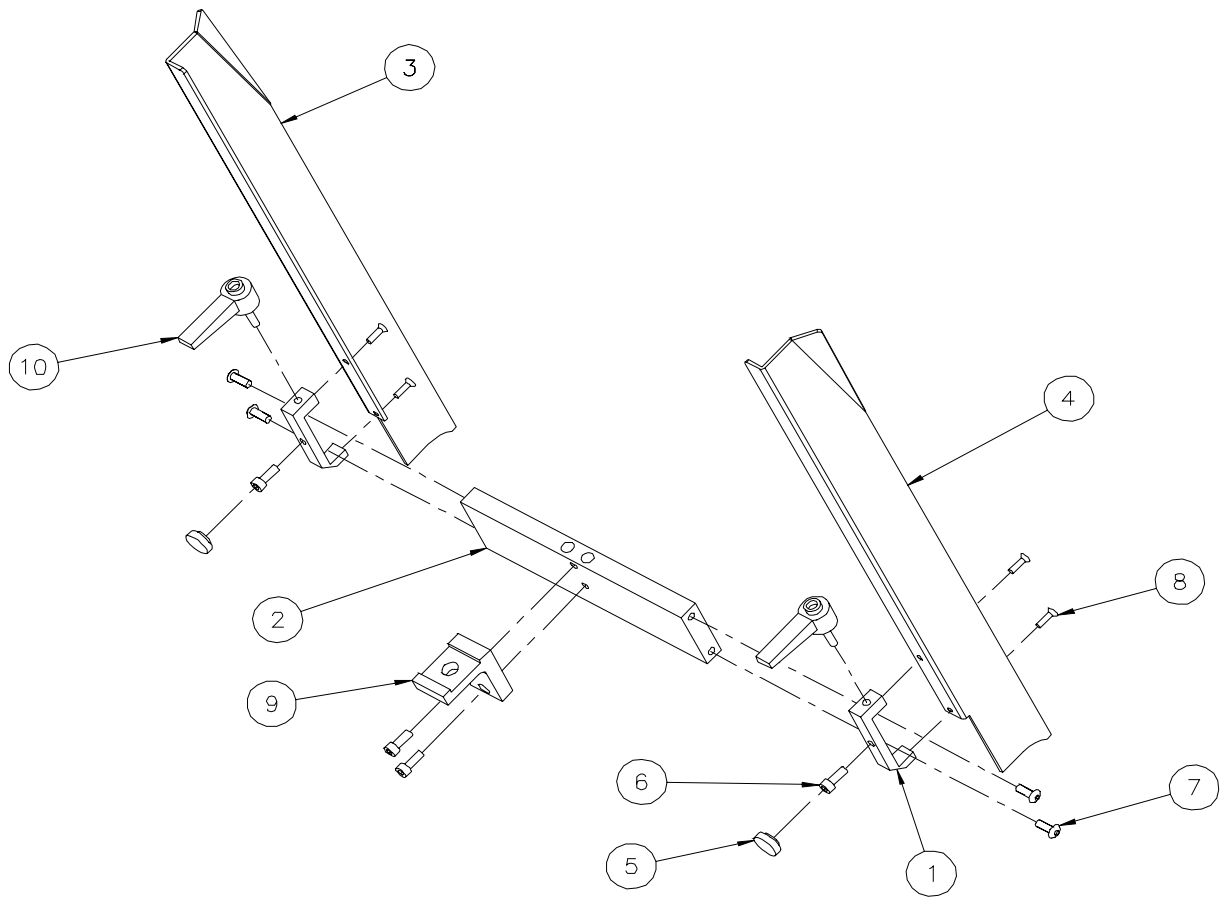

Pitney Bowes
Direct Mail Solutions

SECTION 6

FEEDER SHAFTS ASSEMBLY (Fig. 6-4)

ITEM	PART NO.	QTY.	DESCRIPTION
1	10004-035	1	SHAFT, FRONT, 900-P
2	10004-121	1	SHAFT, NIP ROLLER, 3/4", 900-P
3	10004-064	1	SHAFT, SUPPORT IDLER, 900-P
4	10004-034	1	SHAFT, NIP ROLLER, 900-P
5	10006-070	2	ROLLER, NIP, 3/4 BORE
6	10006-071	1	PULLEY, MATE, 3/4 BORE
7	10006-018	1	PULLEY, CROWNED
8	10006-007	2	FEEDER ROLL
9	99002-006	2	PULLEY, 24XL037
10	99002-003	2	PULLEY, 20XL037
11	10006-012	1	ROLLER, IDLER
12	99003-083	4	BEARING, 1/2" ID X 1-1/8, SHIELDED W/ S.R
13	99003-056	2	BEARING, 1/4" ID X 5/8" OD SEALED
14	99003-001	2	BEARING, 3/8 ID X 7/8 OD, SHIELDED
15	99022-004	2	SNAP RING, 1/2
16	99022-003	2	SNAP RING, 3/8
17	99003-018	5	WASHER, NYLON, 1/2 X 1/16
18		2	SCREW, BTN HD, 10-24 X 1/2
19		8	SCREW, SET, 8-32 X 3/8
20		8	SCREW, SET, 10-24 X 3/8

Pitney Bowes Direct Mail Solutions

SECTION 6

FIG. 4

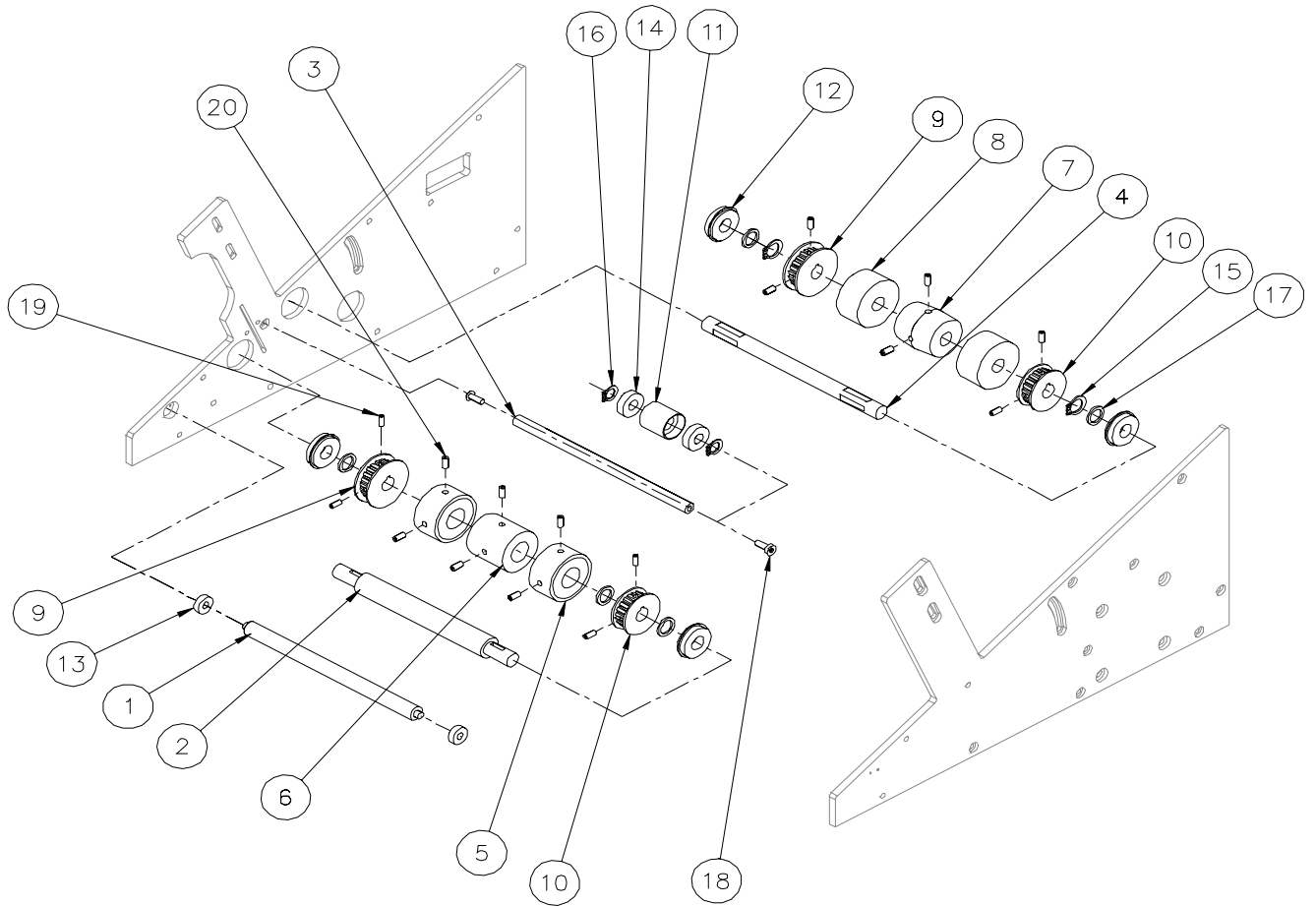

Pitney Bowes
Direct Mail Solutions

SECTION 6

CLUTCH SHAFT AND MOTOR ASSEMBLY (Fig. 6-5)

ITEM	PART NO.	QTY.	DESCRIPTION
1	99001-002	1	MOTOR, 4Z140
2	99008-010	1	CLUTCH / BRAKE, 90 VOLTS
3	10006-077	1	PULLEY, CLUTCH 36XL037
4	99002-004	1	PULLEY, 22XL037
5	99002-007	1	PULLEY, MOTOR 16XL037
6	10004-157	1	SHAFT, CLUTCH SE-600-P
7	10008-006	1	STOP, CLUTCH
8	10012-001	4	STANDOFF, MOTOR
9	99003-083	2	BEARING, 1/2" ID X 1-1/8" SHIELDED W/ S.R.
10	99022-004	2	RETAINING RING, 1/2
11	99003-018	2	WASHER, NYLON, 1/2 X 1/16
12		5	SCREW, BTN HD, 10-24 X 1/2
13		3	SCREW, PAN HD, 6-32 X 1/2
14	99006-021	1	PIN, ROLL, 3/16 X 1 1/4
15		4	SCREW, SET, 1/4-20 X 3/4
16		2	SCREW, SET, 8-32 X 3/8
17		2	SCREW, SET, 8-32 X 1/4

Pitney Bowes Direct Mail Solutions

SECTION 6

FIG.5

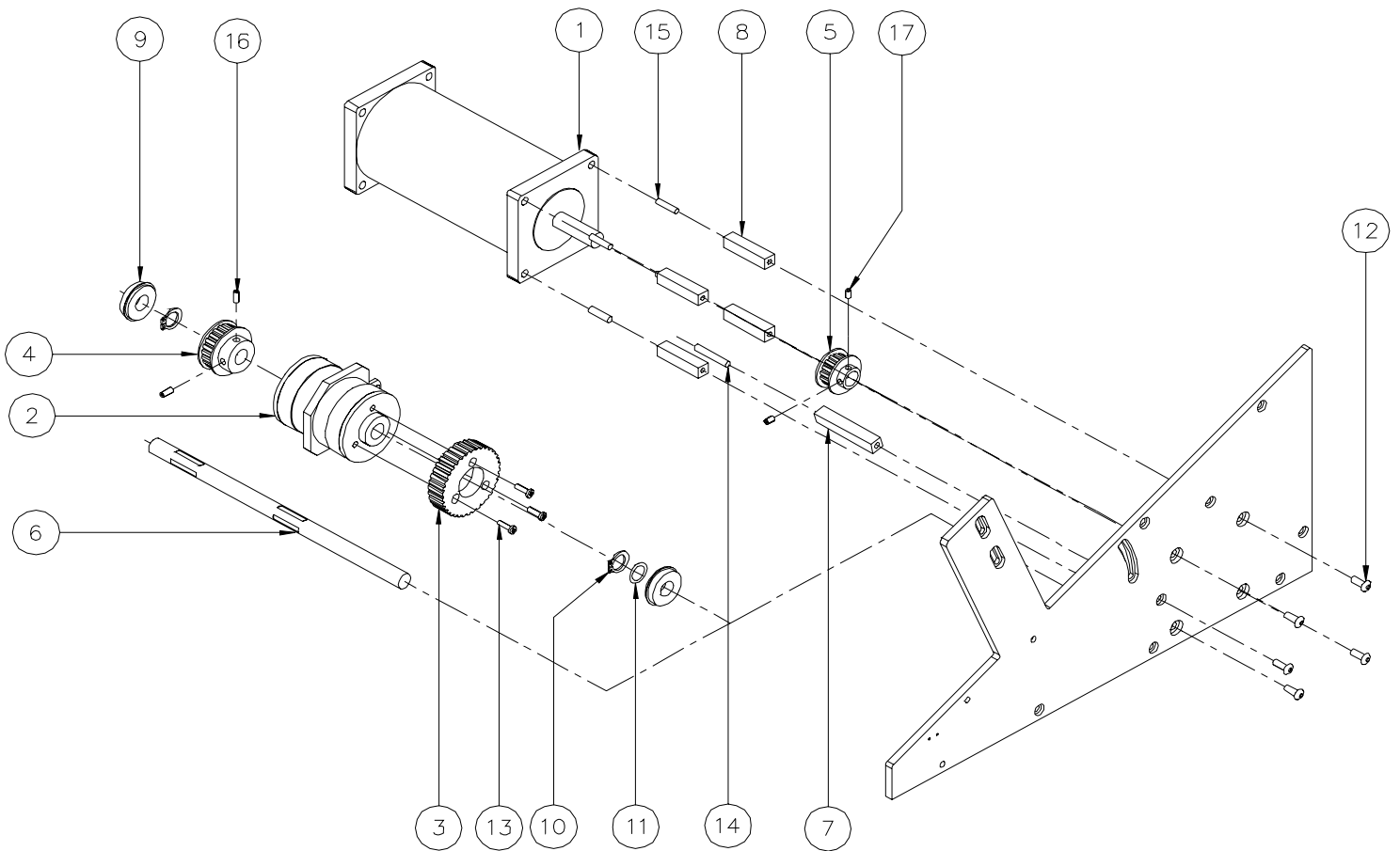

Pitney Bowes
Direct Mail Solutions

SECTION 6

PAPER SLIDE ASSEMBLY (Fig. 6-6)

ITEM	PART NO.	QTY.	DESCRIPTION
1	10009-003	1	BRACKET, PAPER SLIDE
2	10004-014	2	SHAFT, PAPER SLIDE SE-900
3	10005-016	4	SLIDE, PAPER
4	99022-001	8	RETAINING RING, 1/4
5	99004-002	1	KNOB, #10 SCREW
6		1	SCREW, SKT HD, 10-24 X 1/2
7	10007-003	1	NUT, PAPER SLIDE
8	10007-004	1	WASHER, PAPER SLIDE
9	99006-020	1	PIN, ROLL, 5/32 X 3/4
10		1	WASHER, FLAT, #6

Pitney Bowes Direct Mail Solutions

SECTION 6

FIG. 6-6

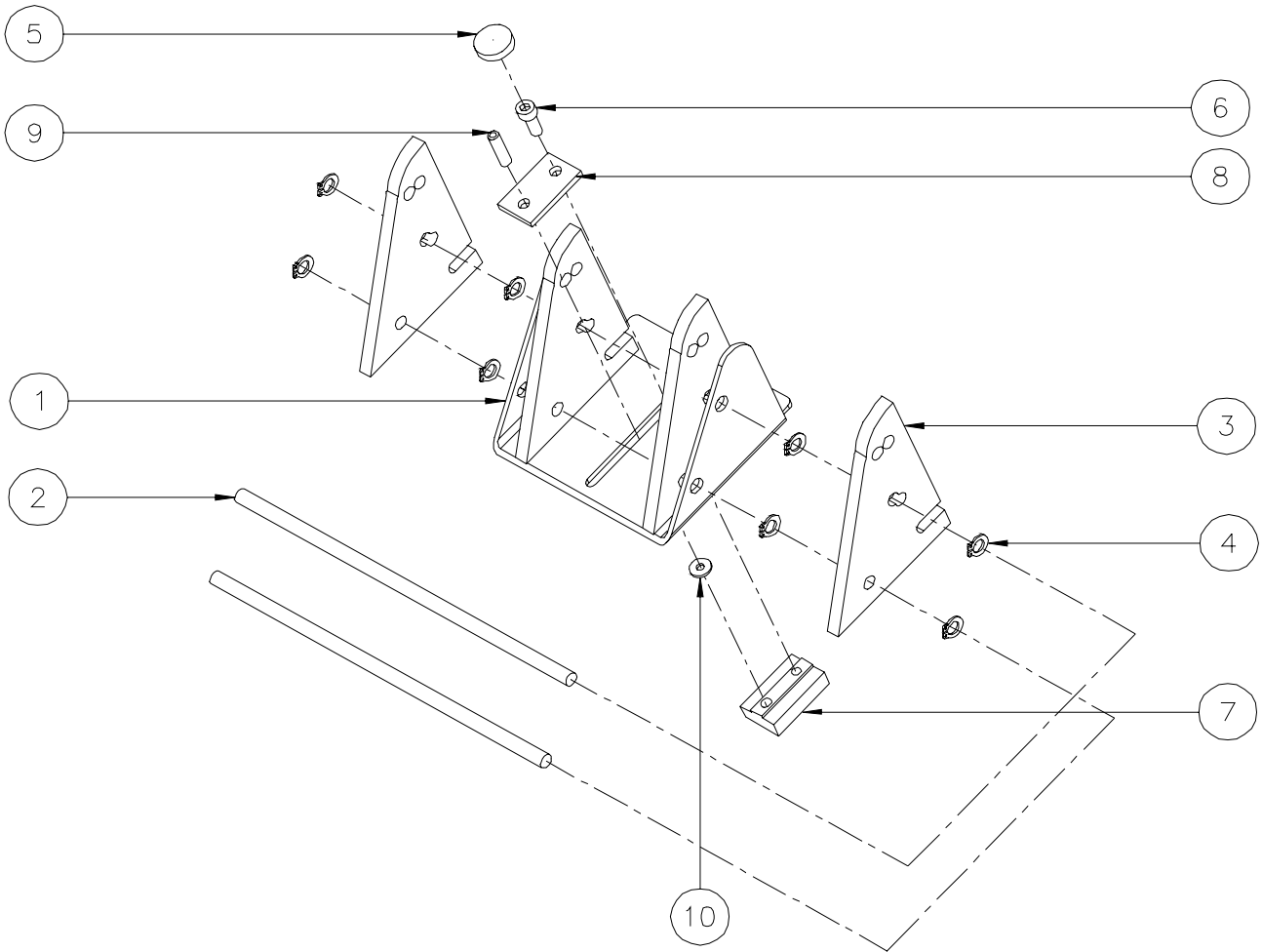

Pitney Bowes
Direct Mail Solutions

SECTION 6

CHASSIS ASSEMBLY (Fig. 6-7)

ITEM	PART NO.	QTY.	DESCRIPTION
1	10000-007	1	SIDE FRAME, LH (SE-600-P)
2	10000-008	1	SIDE FRAME, RH (SE-600-P)
3	10001-008	1	COVER, TOP
4	10002-007	1	COVER, BOTTOM
5	10008-026	2	CROSS BRACE, LOWER
6	10008-027	1	CROSS BRACE, UPPER
7	99007-001	5	SUCTION CUP, FOOT
8		6	SCREW, BTN HD, 10-24 X 1/2
9		8	SCREW, BTN HD, 10-24 X 3/8
10		8	NUT, PEM 10-24
11		4	SCREW, SKT, HD, 10-24 X 1
12	10010-003	5	FOOT, BOTTOM
13		1	SCREW, SKT HD, 10-24 X 1/2

Pitney Bowes Direct Mail Solutions

SECTION 6

FIG. 6-7

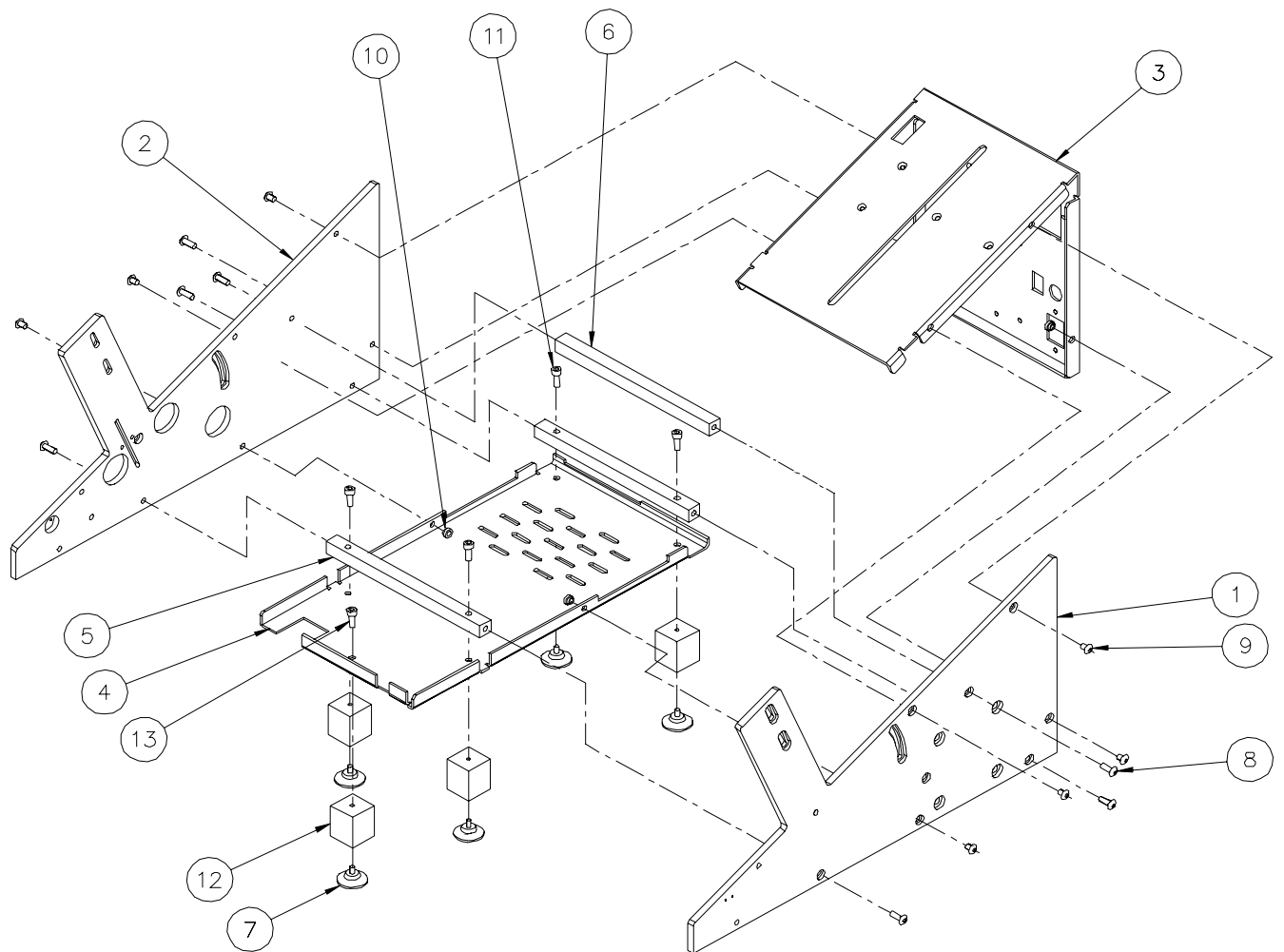

Pitney Bowes
Direct Mail Solutions

SECTION 6

ELECTRICAL COMPONENT ASSEMBLY (Fig. 6-8)

ITEM	PART NO.	QTY.	DESCRIPTION
1	98000-001	1	SWITCH, POWER (RED ROCKER)
2	98001-002	1	TERMINAL STRIP
3	98006-002	1	CIRCUIT BOARD (IO)
4	98006-005	1	CIRCUIT BOARD, SWITCH
5	98006-006	1	CIRCUIT BOARD, BATCH COUNTER (600-PC ONLY)
6	98005-001	1	CONTROLLER, MOTOR, 90V DC W/ SPEED POT
7	98009-009	1	COUNTER, BATCH (600-PC ONLY)
7	98009-010	1	COUNTER, CYCLE (600-PS ONLY)
8	98008-001	1	TRANSFORMER
9	98004-001	1	CIRCUIT BREAKER, 2 AMP
10	98003-001	1	RECEPTACLE, POWER CORD
11	99004-015	2	KNOB, SPEED POT
12	98000-033	1	SWITCH, ROCKER (SMALL, RED)
13	98006-007	1	POT KIT, TIME DELAY (PC) / AUTO RESTART (PS)
	98009-003	1	SENSOR, FREE HANGING (NOT SHOWN)
	98010-001	1	CABLE, SENSOR (YELLOW) (NOT SHOWN)
	98010-007	1	RIBBON CABLE (IO BOARD) (NOT SHOWN)
	98007-005	1	CORD, POWER (NOT SHOWN)
		2	SCREW, PAN HD 6-32 X 3/4
		10	SCREW, PAN HD 6-32 X 1/2
		4	SCREW, FLAT HD 6-32 X 1/2
		14	NUT, HEX 6-32

Pitney Bowes
Direct Mail Solutions

SECTION 6

TRAILING ARM ASSEMBLY (fig. 6-9)

ITEM	PART NO.	QTY.	DESCRIPTION
1	10011-006	2	PLATE, ROLLER MTG. (ECO TONGUE)
2	10012-003	2	SPACER
3	10006-016	2	ROLLER
4	10004-007	2	WEIGHT
5		2	SCREW, PAN HD, 8-32 X 1 1/4
6		2	SCREW, PAN HD, 8-32 X 3/8
7		4	WASHER, LOCK INT. TOOTH #8

Pitney Bowes Direct Mail Solutions

SECTION 6

FIG. 6-9

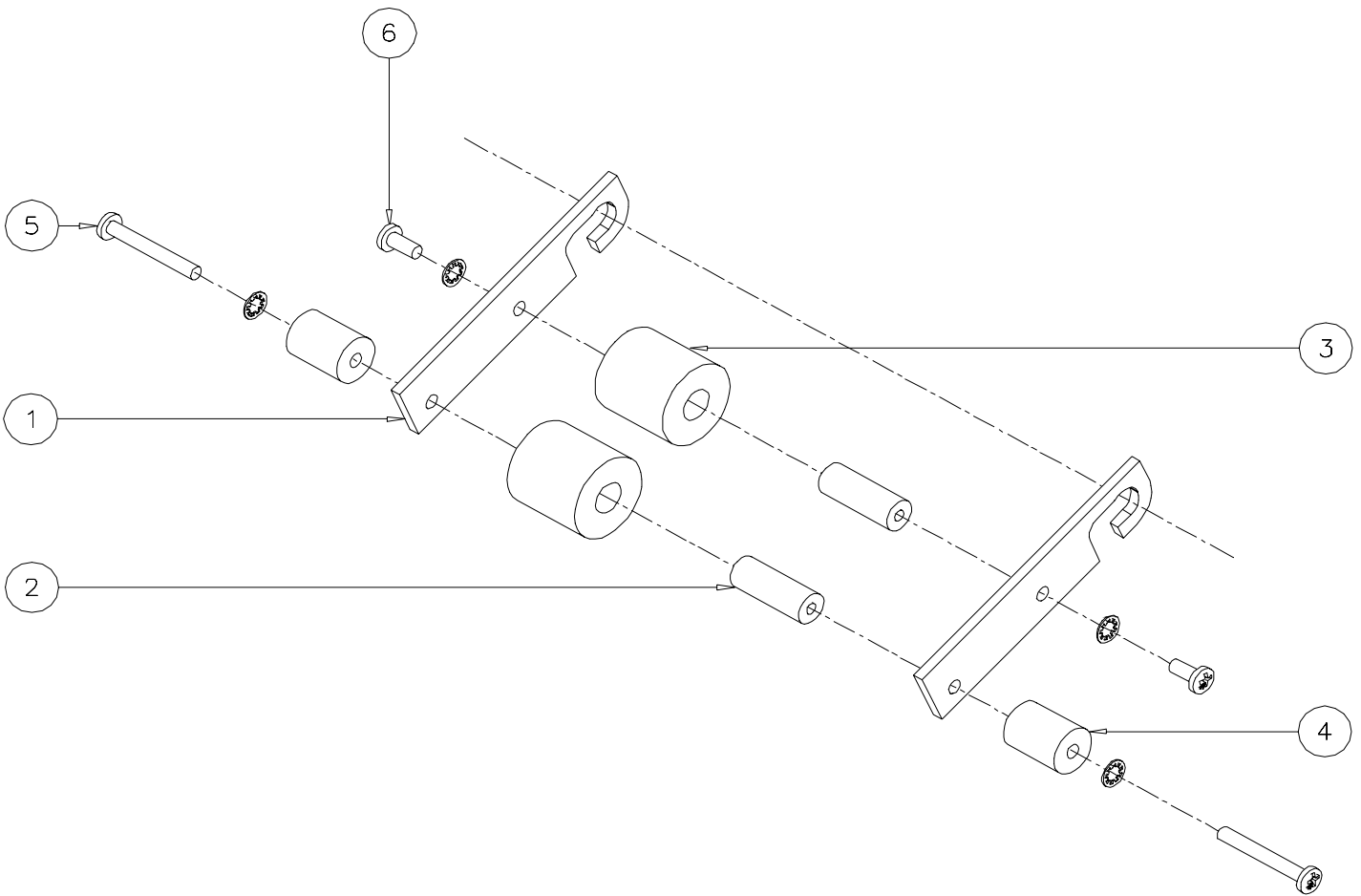

Pitney Bowes
Direct Mail Solutions

SECTION 6

ACCELERATOR ASSEMBLY (fig. 6-10)

ITEM	PART NO.	QTY.	DESCRIPTION
1	SEE FIG. 6-11	1	ACCELERATOR CHASSIS ASSEMBLY
2	SEE FIG. 6-12	1	1 ST ACCELERATOR SHAFT ASSEMBLY
3	SEE FIG. 6-12	1	2 ND ACCELERATOR SHAFT ASSEMBLY
4	SEE FIG. 6-12	1	3 RD ACCELERATOR SHAFT ASSEMBLY
5	SEE FIG. 6-13	1	ROLLER RACK ASSEMBLY
6	SEE FIG. 6-14	1	INTERMEDIATE DRIVE PULLEY ASSEMBLY

Pitney Bowes
Direct Mail Solutions

SECTION 6

FIG 6-10

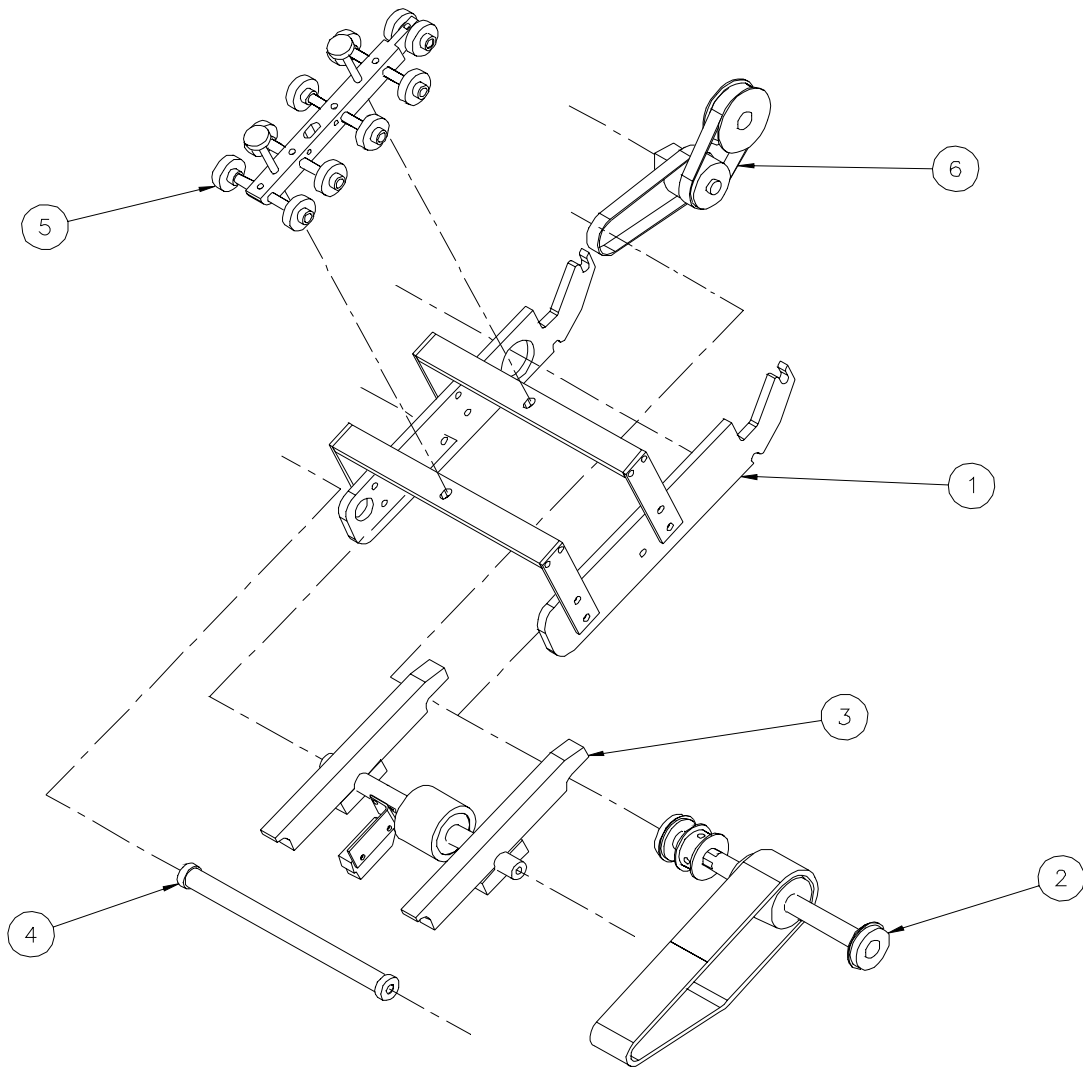

Pitney Bowes
Direct Mail Solutions

SECTION 6

ACCELERATOR CHASSIS ASSEMBLY (fig. 6-11)

ITEM	PART NO.	QTY.	DESCRIPTION
1	10000-011	1	SIDE FRAME, LH ACCELERATOR (PC/PS)
2	10000-012	1	SIDE FRAME, RH ACCELERATOR (PC/PS)
3	10008-013	2	BAR, ROLLER RACK MTG (SE-600-P)
4	10008-009	4	BAR, ROLLER RACK SUPPORT
5	99003-006	4	SCREW, SHOULDER, 1/4X1/4
6		8	SCREW, BTN HD, 10-24 X 3/8
7		8	SCREW, SKT HD, 8-32 X 1/2

Pitney Bowes
Direct Mail Solutions

SECTION 6

FIG. 6-11

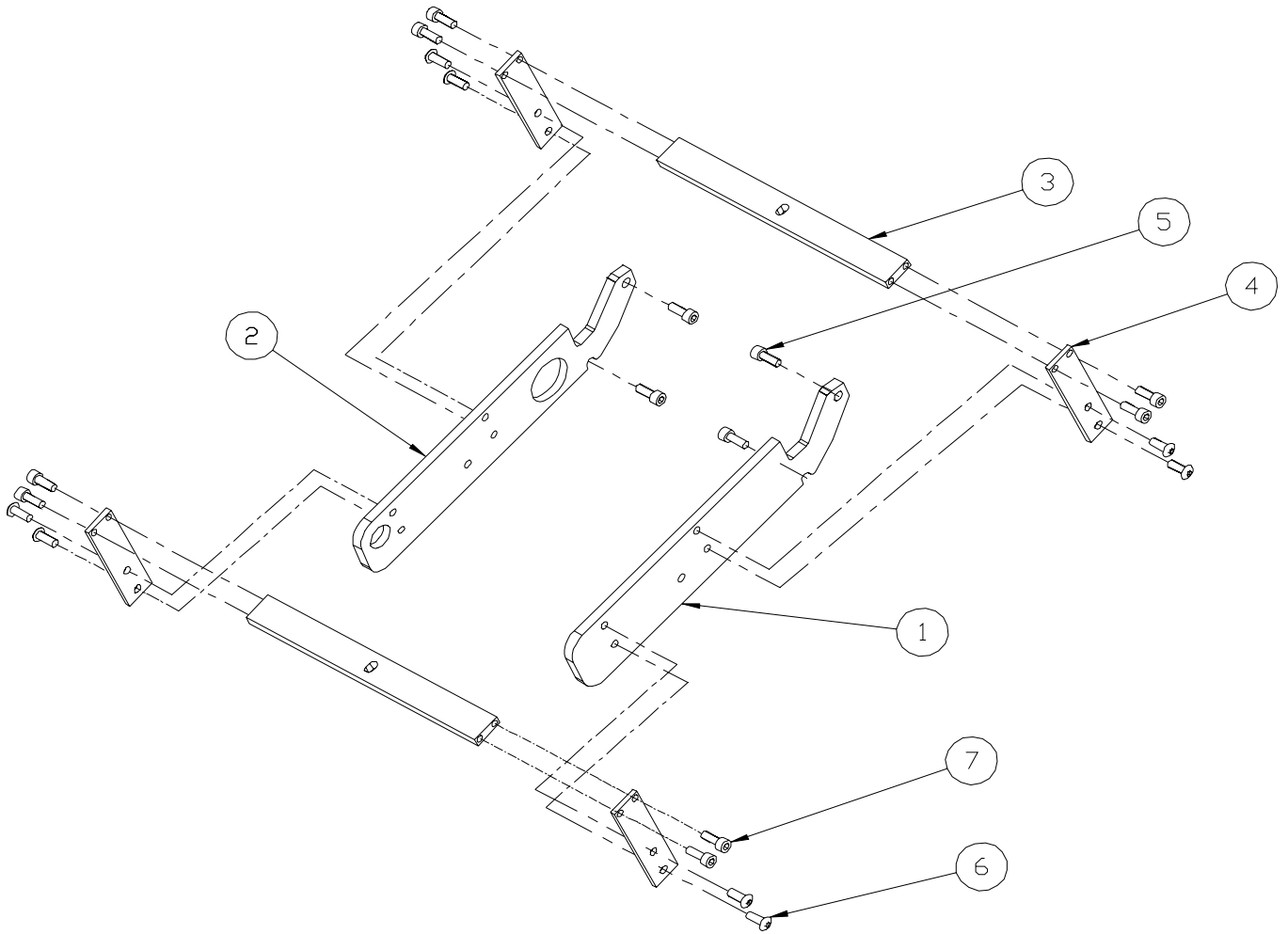

Pitney Bowes
Direct Mail Solutions

SECTION 6

ACCELERATOR SHAFTS ASSEMBLY (fig. 6-12)

ITEM	PART NO.	QTY.	DESCRIPTION
1	10004-031	1	SHAFT, FRONT (ACCELERATOR) SE-600-P
2	10004-029	1	SHAFT, SUPPORT IDLER (ACCELERATOR) SE-600-P
3	10004-032	1	SHAFT, DRIVE (ACCELERATOR) SE-600-P
5	10006-017	1	PULLEY, MATE
6	10006-018	1	PULLEY, CROWNED
7	10005-021	2	PAPER SLIDE
8	10007-009	2	PLATE, CLAMP
9	10009-004	1	BRACKET, SENSOR MOUNTING
10	99003-083	2	BEARING, 1/2 X 1-1/8, SHIELDED W/ S.R.
11	99003-083	2	BEARING, 1/2 X 1-1/8, SHIELDED W/ S.R.
12	99003-056	2	BEARING, 1/4 X 5/8 SEALED
13	99002-028	1	PULLEY, 14XL037
14	99000-004	1	BELT, RED GUM
15	99022-004	4	SNAP RING, 1/2
16	98009-002	1	SENSOR, RECIEVER
17		2	SCREW, BTN HD, 10-24 X 1/2
18		4	SCREW, BTN HD, 10-24 X 3/4
19		2	SCREW, PAN HD, M3 X 5

Pitney Bowes
Direct Mail Solutions

SECTION 6

FIG 6-12

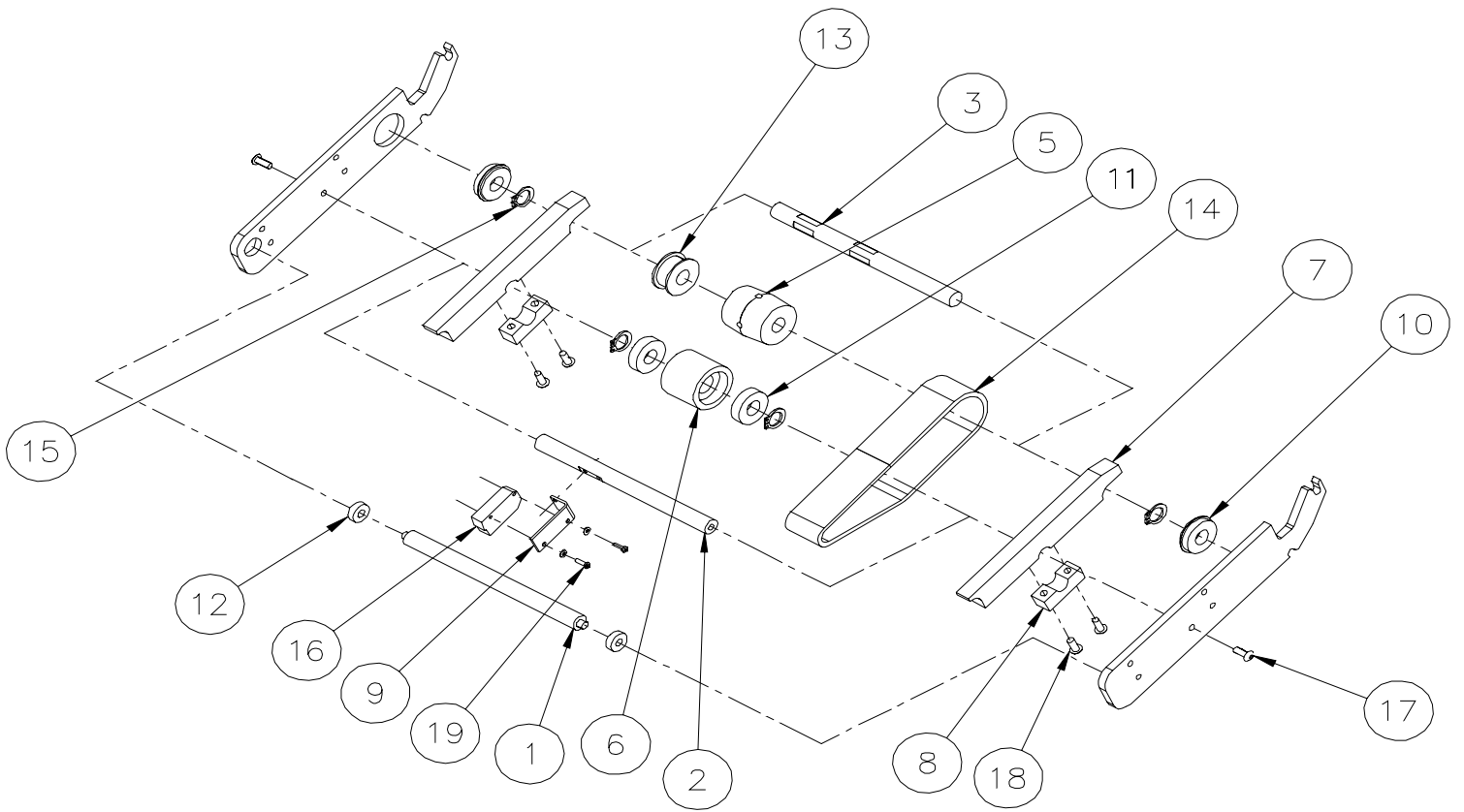

Pitney Bowes
Direct Mail Solutions

SECTION 6

ROLLER RACK ASSEMBLY (Fig. 6-13)

ITEM	PART NO.	QTY.	DESCRIPTION
1	10008-004	1	BAR, ROLLER RACK
2	10004-025	4	SHAFT, ROLLER RACK, 3"
3	10004-062	1	SHAFT, ROLLER RACK 1 1/4
4	99003-001	10	BEARING, 3/8 X 7/8
5	99003-005	10	BUSHING, 1/4 X 3/8 X 5/16
6	10009-005	1	PLATE, SENSOR MOUNTING
7	98009-002	1	SENSOR, SENDER
8	99005-011	2	SPRING
9	99022-001	20	SNAP RING 1/4
10	99004-005	2	KNOB, FEM, 10-32
11	99032-004	2	STUD, 10-32 X 2 1/2
12		5	SCREW, SET, 8-32 X 1/8
13		2	SCREW, SKT HD, 6-32 X 1/4
14		2	SCREW, PAN HD, M3 X 5
15		2	WASHER, FLAT, M3
16		3	NUT, HEX, 10-32
17		6	WASHER, FLAT, #10
18	10005-039	1	GUIDE, SPRING STEEL, ROLLER RACK
19		1	NUT, HEX, 8-32

Pitney Bowes Direct Mail Solutions

SECTION 6

FIG 6-13

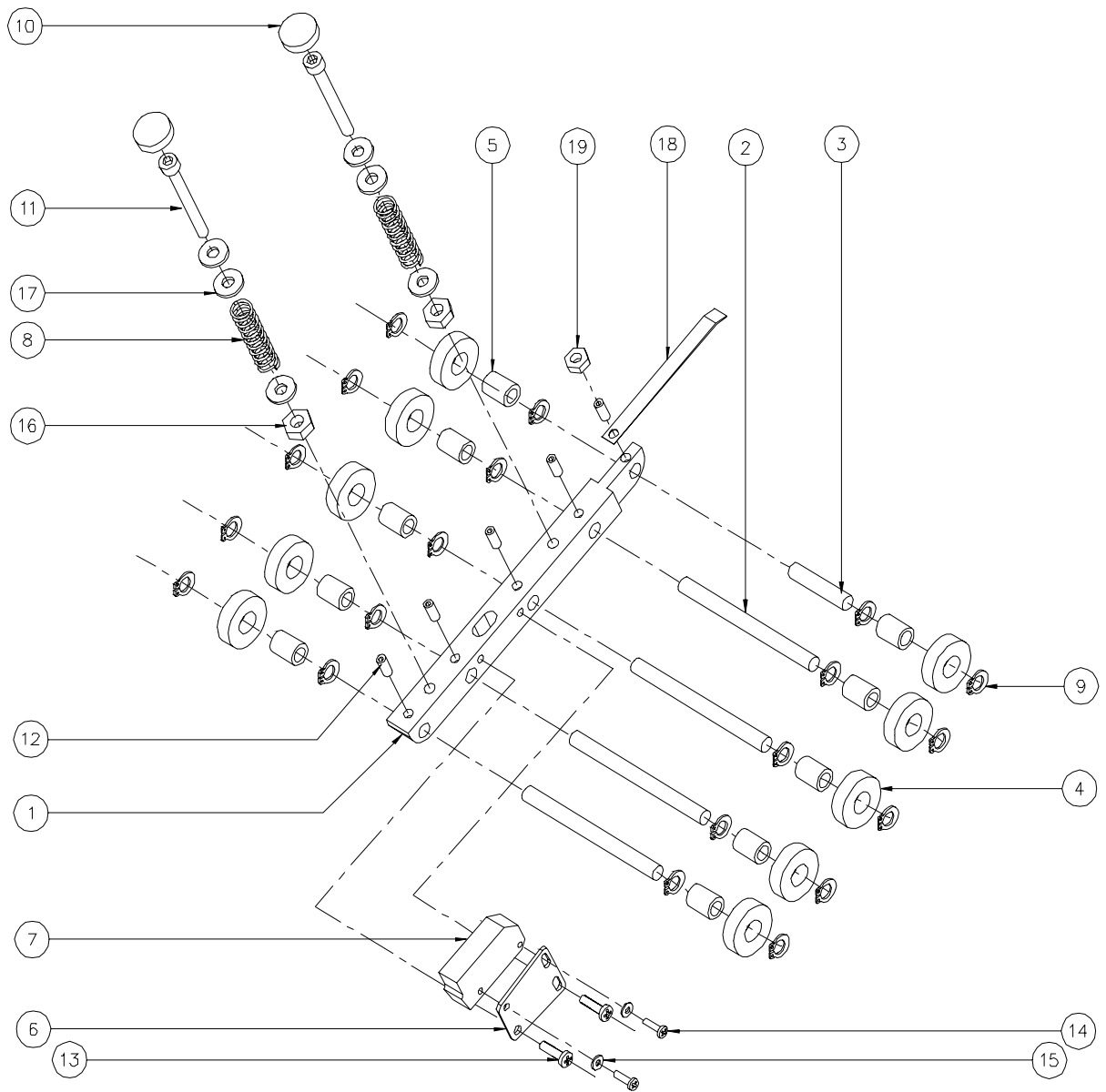

Pitney Bowes
Direct Mail Solutions

SECTION 6

INTERMEDIATE DRIVE PULLEY ASSEMBLY (fig. 6-14)

ITEM	PART NO.	QTY.	DESCRIPTION
1	10004-015	1	SHAFT, IDLER
2	10007-011	1	BLOCK, IDLER SHAFT
3	10006-027	1	PULLEY, 20XL100
4	99000-040	1	BELT, 80XL037
5	99000-001	1	BELT, 90XL037
6	99003-001	2	BEARING, 3/8 X 7/8, SHIELDED
7	99022-003	2	SNAP RING, 3/8
8		1	SCREW, BTN HD, 10-24 X 1/8
9	99003-016	1	WASHER, NYLON, 3/8 X 1/32

Pitney Bowes *Direct Mail Solutions*

SECTION 6

FIG. 6-14

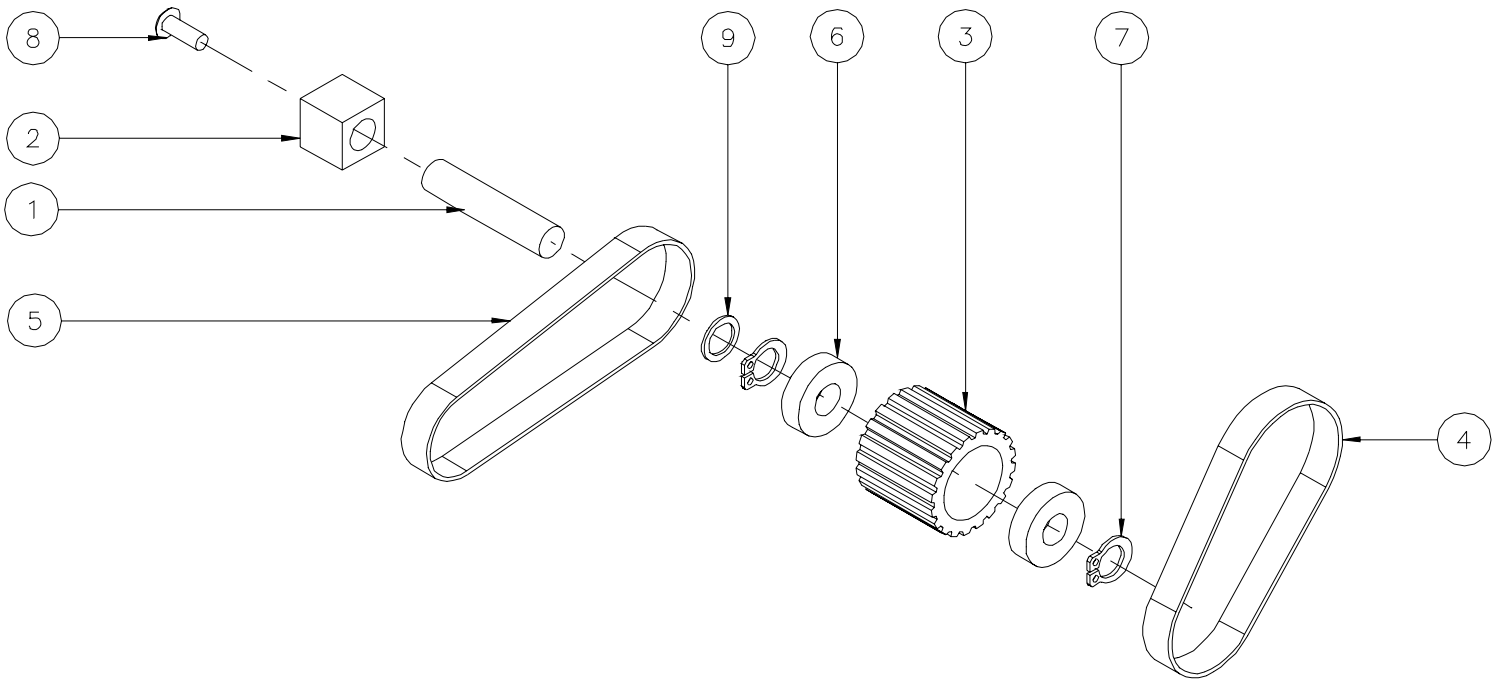

Pitney Bowes
Direct Mail Solutions

SECTION 7

Pitney Bowes DMS
SE 600 PC & PS Electrical Schematics

Pitney Bowes Direct Mail Solutions

600 PC

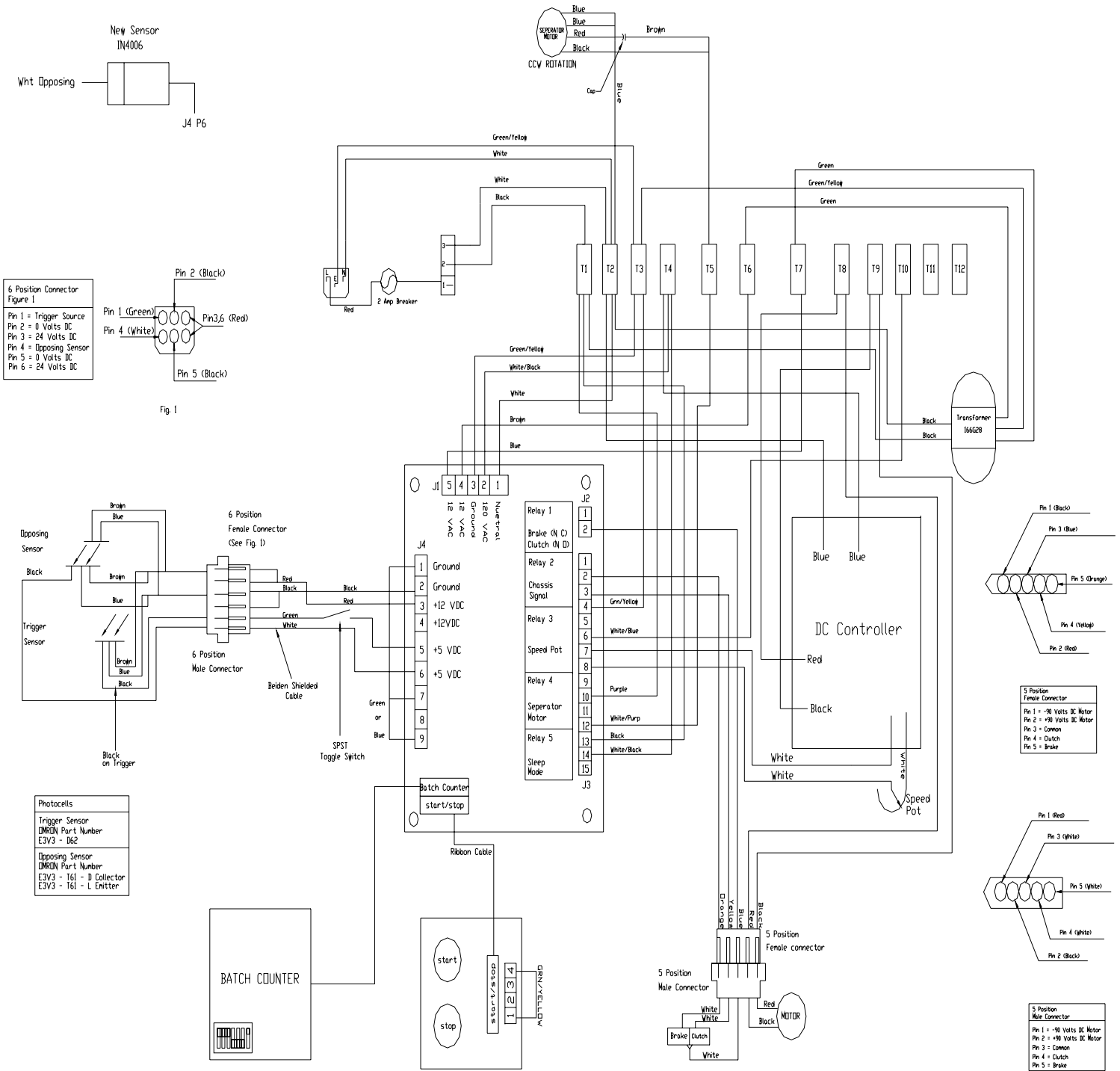

Pitney Bowes Direct Mail Solutions

600 PS

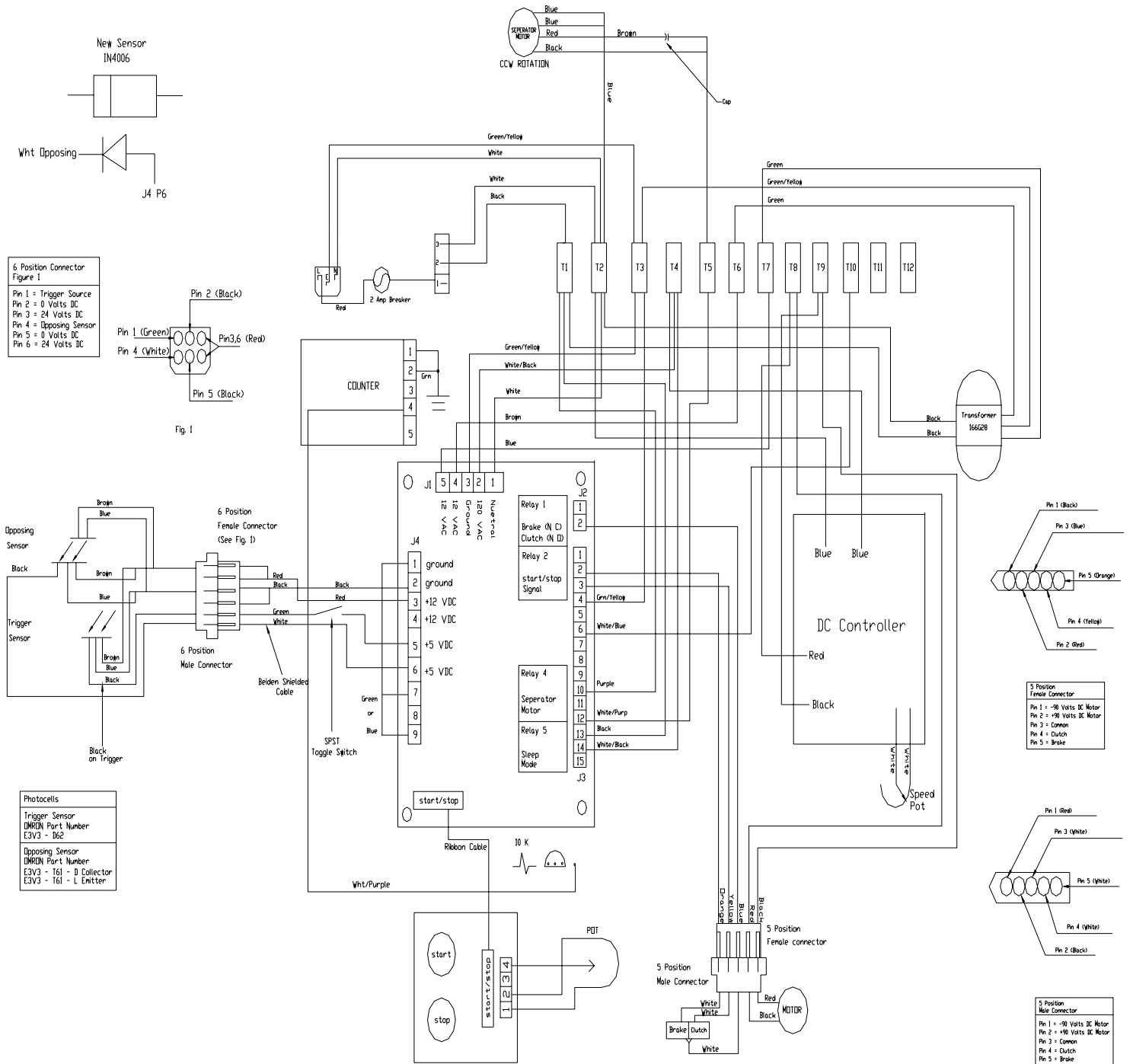

Pitney Bowes DMS
SE 600 P-SERIES

2 Year Limited Warranty

Pitney Bowes DMS warrants this product to be free from defects in materials and workmanship for a period of two years from the date of delivery to the customer. If at any time during this two year period, the customer feels that there is an alleged defect in the equipment, written notice must be provided to Pitney Bowes DMS who will determine a time to have the feeder inspected in the field by a representative of Pitney Bowes DMS or returned to Pitney Bowes DMS corporate headquarters. If the equipment is found to not be in conformity with this warranty, Pitney Bowes DMS will in its sole discretion expeditiously either repair the equipment or supply a replacement.

Please refer to the warranty card included with this manual for additional details of this warranty. Complete the warranty card and return it to Pitney Bowes DMS as soon as possible to activate the warranty on this product.

Procedure

Send all warranty claims to:
Pitney Bowes DMS Warranty Department
12050 49TH Street North
Clearwater, FL 33762
Return freight prepaid.