



FOAM
CONTROL

AQUATURBO® FB

MECHANICAL FOAM REMOVAL SYSTEM



SFA
enviro

TO ASSIST BIO-DIGESTION FB
ASPIRATES AND BREAKS HIGH
VOLUMES OF FOAM FORMING
ON THE SURFACE OF SOME
BIOLOGICAL AND THERMOPHILIC
REACTORS.



Aquaturbo

MAIN CHARACTERISTICS

To assist bio-digestion FB aspirates and breaks high volumes of foam forming on the surface of some biological and thermophilic reactors.

Foam is drawn into the volute where the degassing tube allows air to vent to atmosphere and liquid to re-entrain.

Nothing is discharged from the basin. Applicable in high foam treating biological reactors, high foaming influent, thermophilic reactors, biological treatment of animal waste.



ADVANTAGES

BLOCKAGE FREE + HIGH FLOW VOLUTE

UNIQUE AIR / LIQUID SEPARATION
+ DISCHARGE

RELIABLE + NON CLOGGING IMPELLER

SIMPLE INSTALLATION + REMOVAL

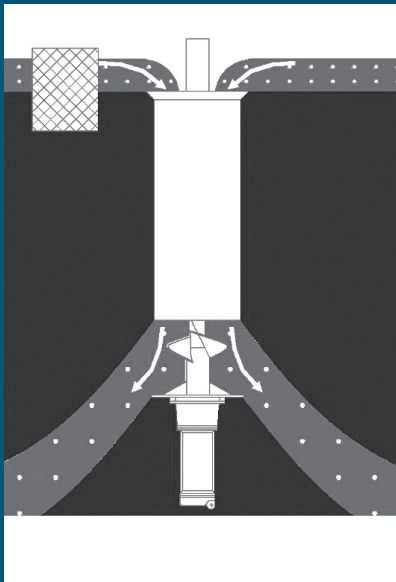

COMPONENTS

- 1.5 - 15KW, submersible motor -IP 68
- 4,6 +8 - Pole Speeds, direct drive
- 2 + 3 float options
- AISI 304/316 or special SS

OPTIONS

- Fixed + float mount options
- Vertical operation only
- 1 x Submerged drive
- Fixed or variable WL options



FOAM BREAKER

FLOATING HIGH FLOW SYSTEM FOR FOAM ASPIRATION AND BREAKING

Model	HP	D1 (inch)	L1 (inch)	H1 (inch)	H2 (inch)	H3 (inch)	Weight (Lbs)
0150-30	2	31	102	66	78	127	590
0220-30	3	31	102	68	80	127	590
0400-30	5	31	102	74	87	134	623
0550-30	7,5	39	129	81	93	142	829
0750-30	10	39	129	92	104	151	869
1100-30	15	39	129	105	118	166	911
1500-30	20	39	129	119	134	181	1093
0150-20	2	31	102	66	79	127	612
0220-20	3	31	102	66	79	127	649
0400-20	5	31	102	86	86	148	750
0550-20	7,5	39	129	94	108	157	1052
0750-20	10	39	129	99	114	161	1056
1100-20	15	39	129	107	120	170	1107
1500-20	20	39	129	121	137	184	1146
0150-20	2	31	102	86	101	148	697
0220-15	3	31	102	86	101	148	700
0400-15	5	39	129	129	108	157	1025
0550-15	7,5	39	129	98	112	160	1049
0750-15	10	39	129	107	122	170	1111
1100-15	15	39	129	121	138	184	1239
1500-15	20	39	129	137	155	200	1562

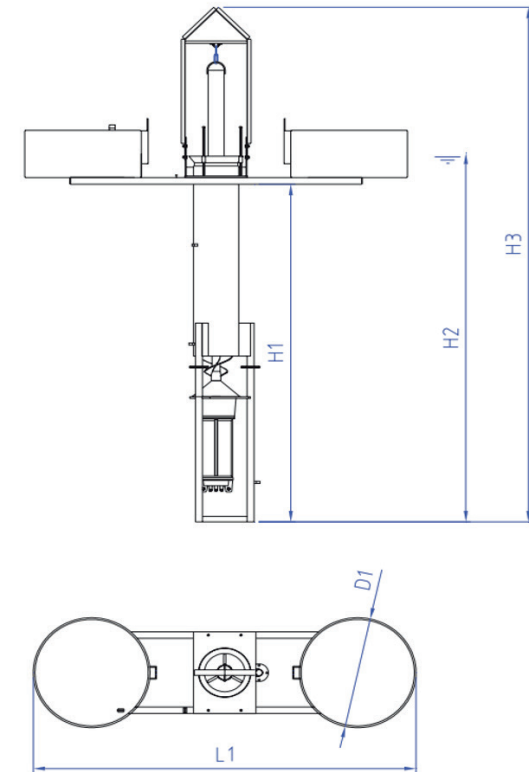

All values are indicative. Aquasystems International N.V. reserves the right to adjust these values at any time.

A STEP AHEAD IN WATER TECHNOLOGY

sfa-enviro.com

 [@sfa_enviro](https://twitter.com/sfa_enviro)

 **SFA** GROUP

