



# A.T. Scouts

Sales·Parts·Service

6250 Moorefield Rd.

Springfield, Ohio 45502

390-0775 or 323-6583



*International*  
MOTOR  
TRUCKS

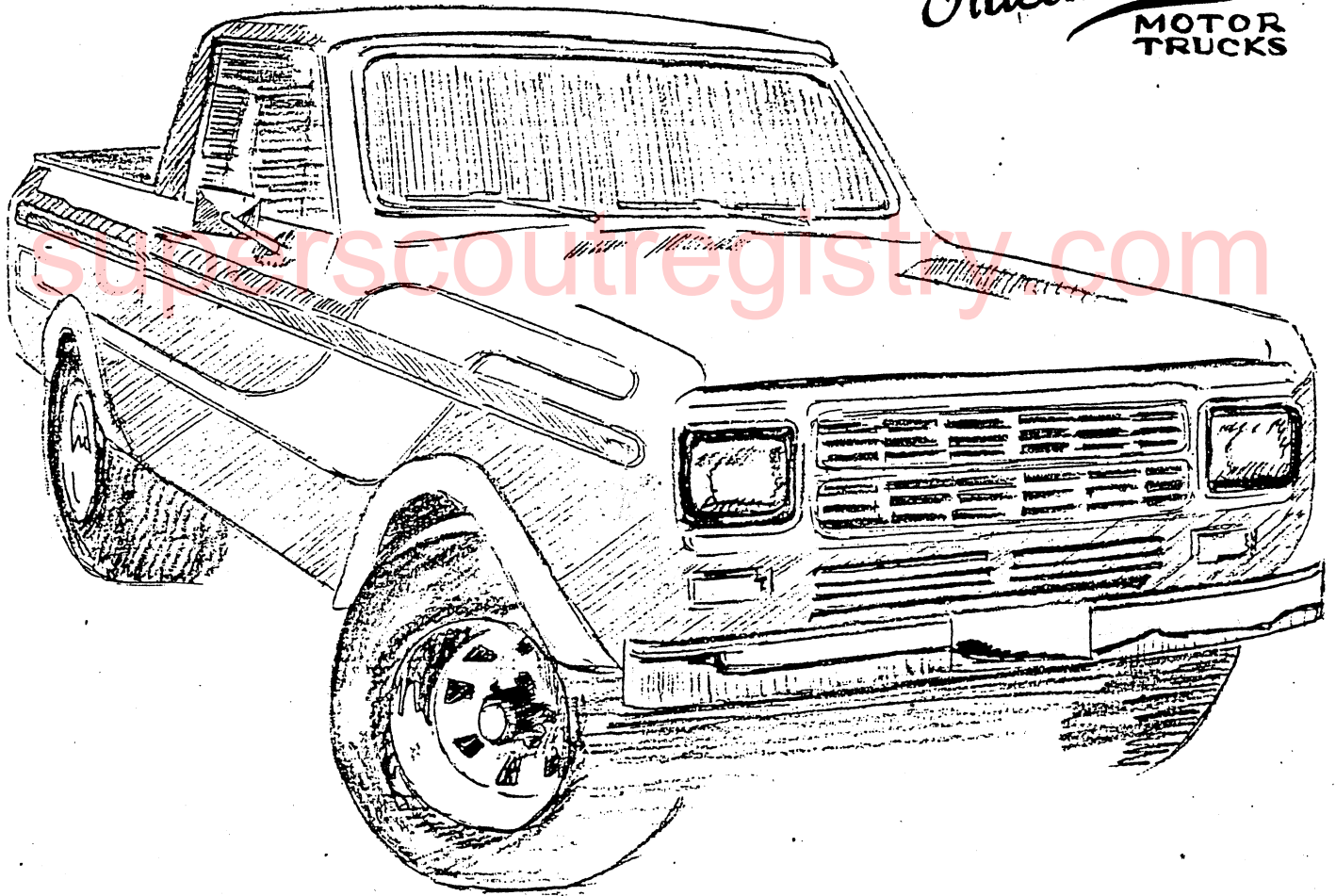

**Save a Scout**  
Custom made Scout parts

**1991**

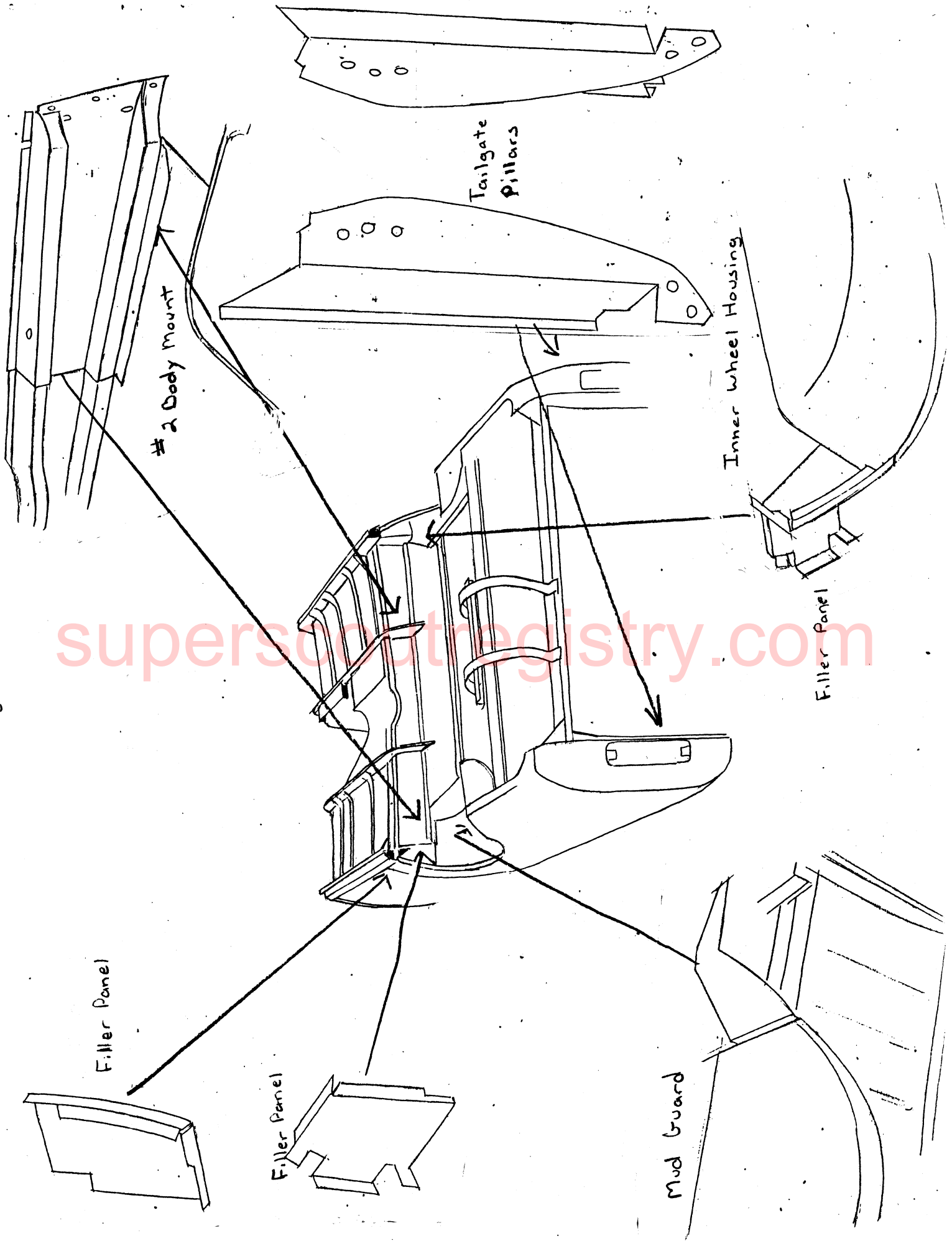

Side View

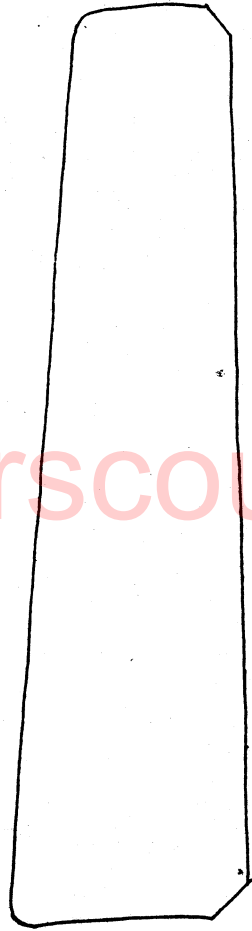
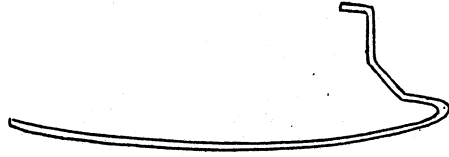

Door Boot

Door Boot takes care of the rusty bottom of the door, inside and out.

superscoutregistry.com

One Piece Body Mounts

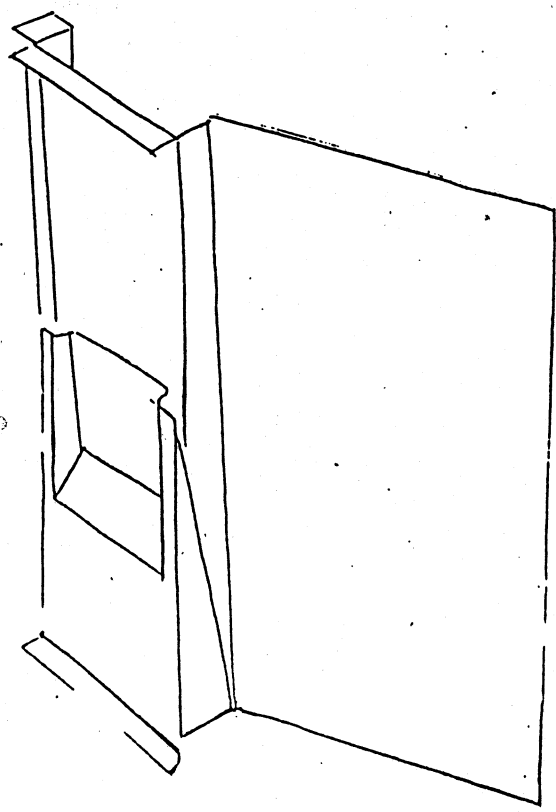
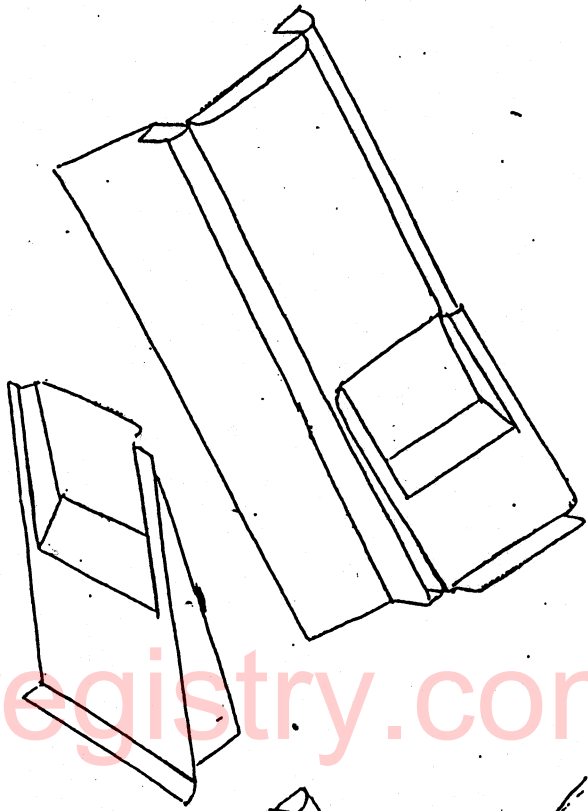
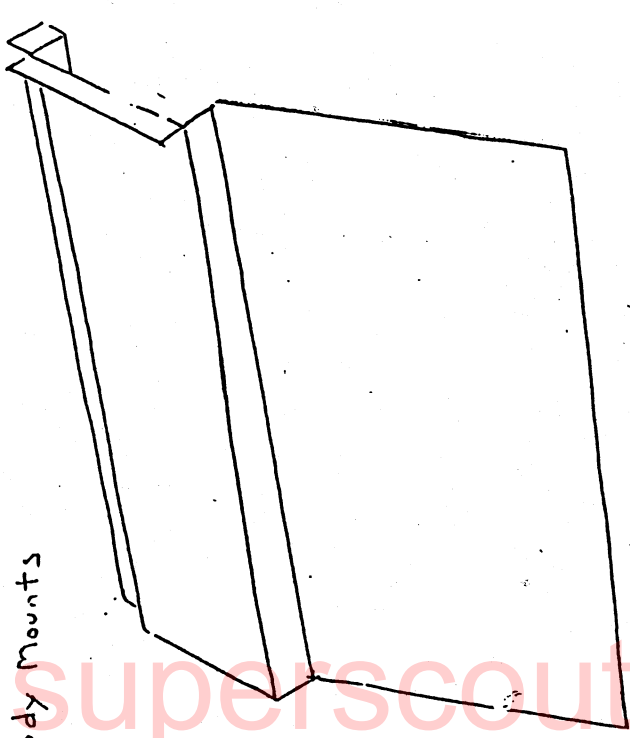

This Piece Flanged Body Mount

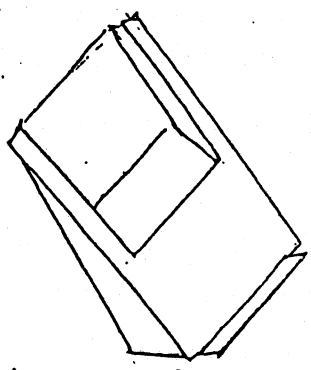
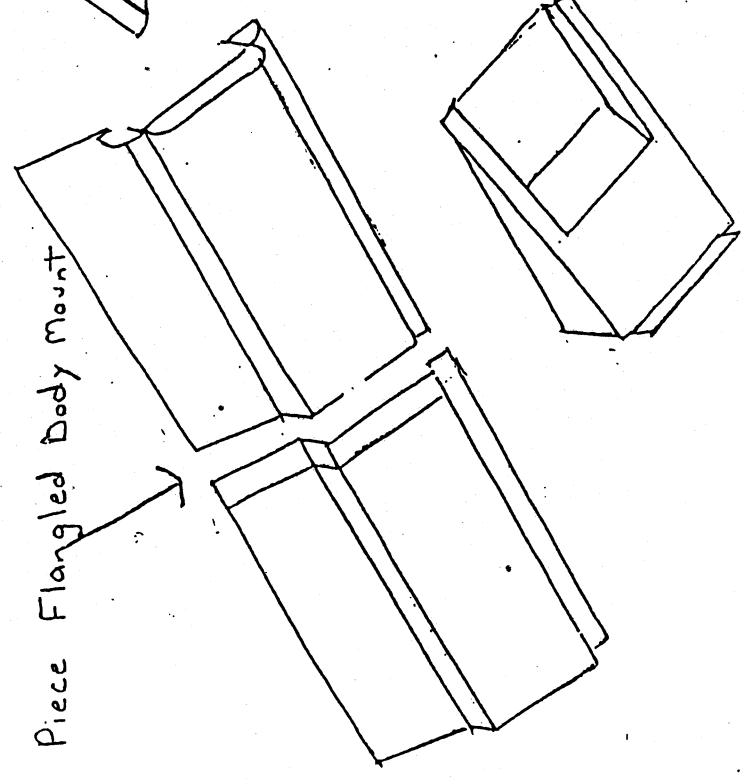

Fiberglass quarter

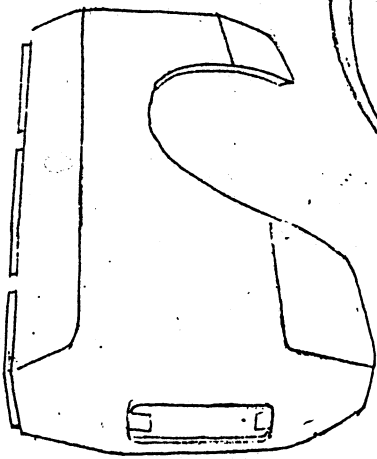

Metal Tailgate

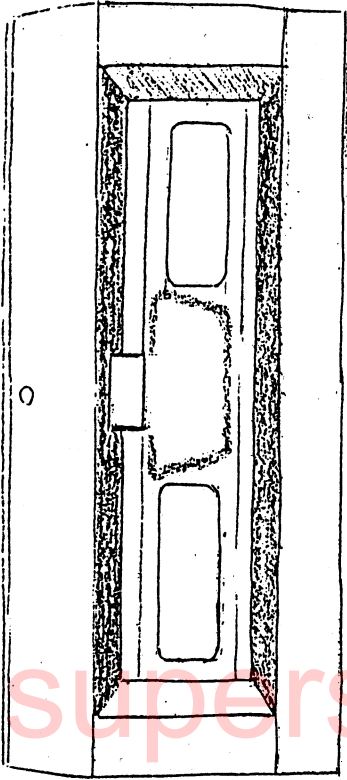

Fiberglass inner wheel well

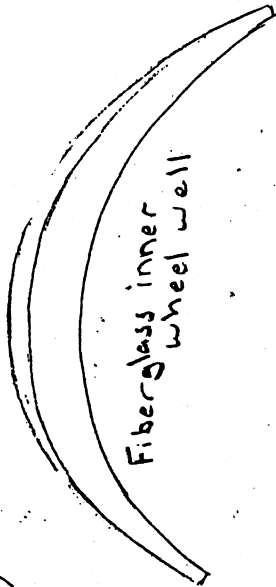

2 piece Rear Floor

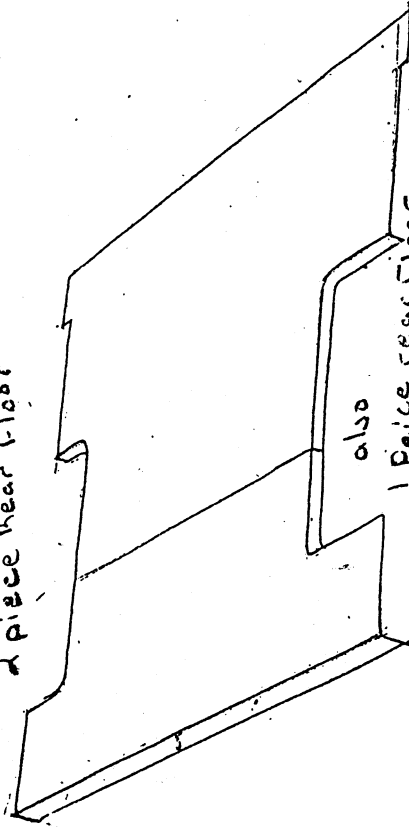

also 1 Piece rear Floor

Metal Windshield

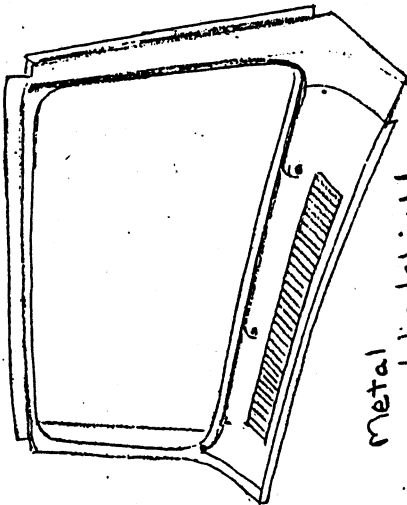

metal Liftgate

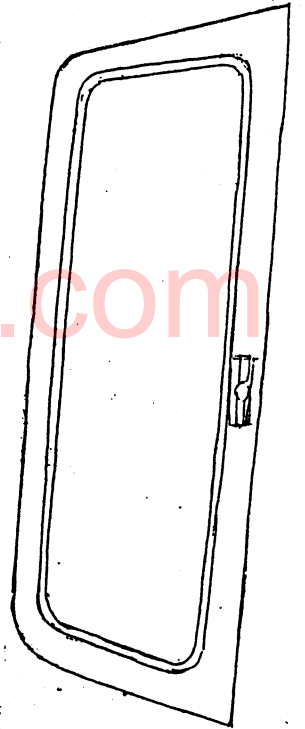

superscoutregistry.com

Filler Panel

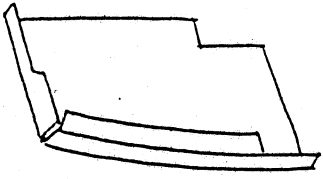

Inner Wheel Housing

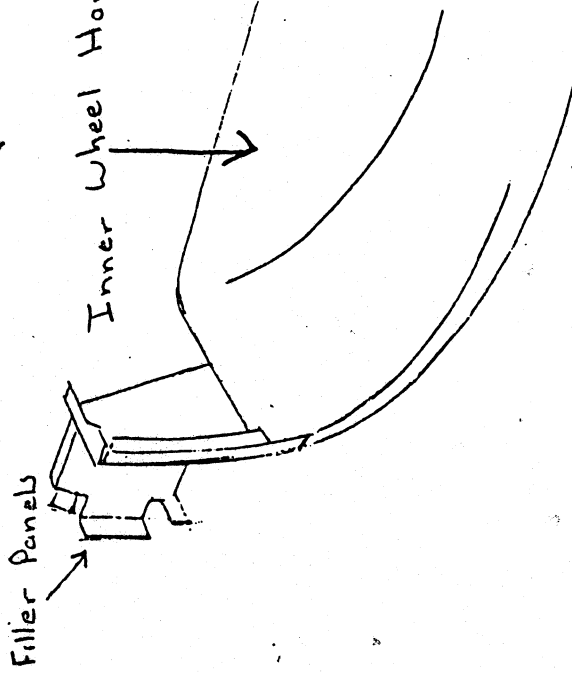

Filler Panels

Filler Panel

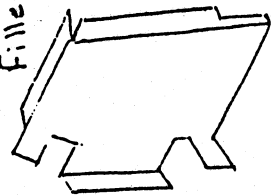

superscoutregistry.com

#2 Body Mount

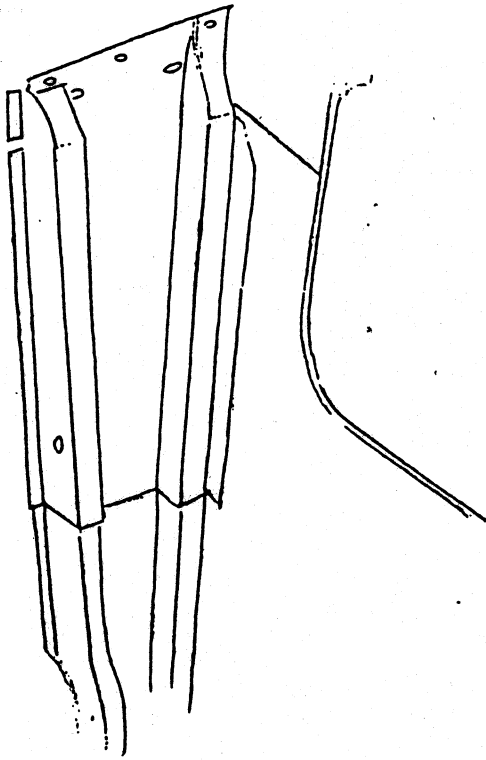

Mud Shield

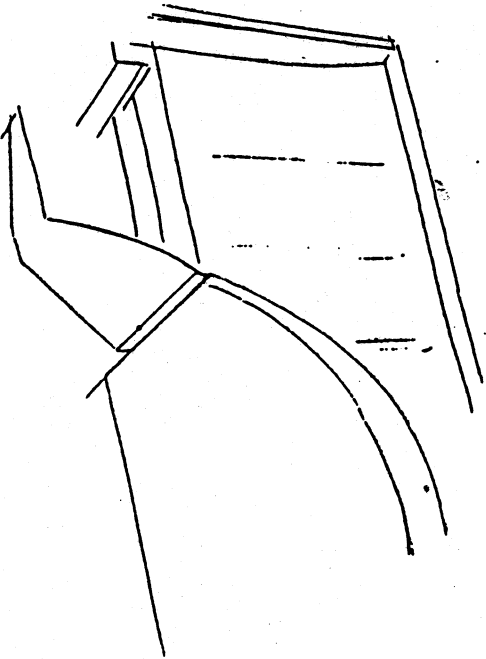

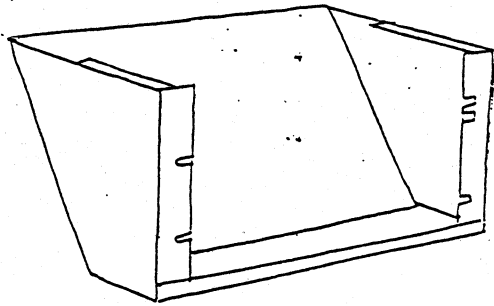

Air Condition Cover

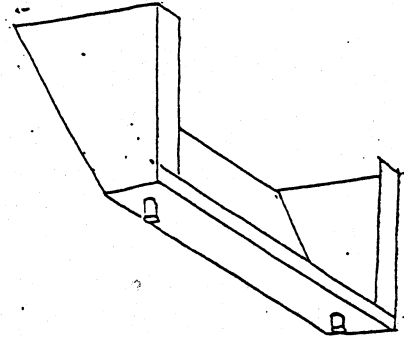

superscoutregistry.com

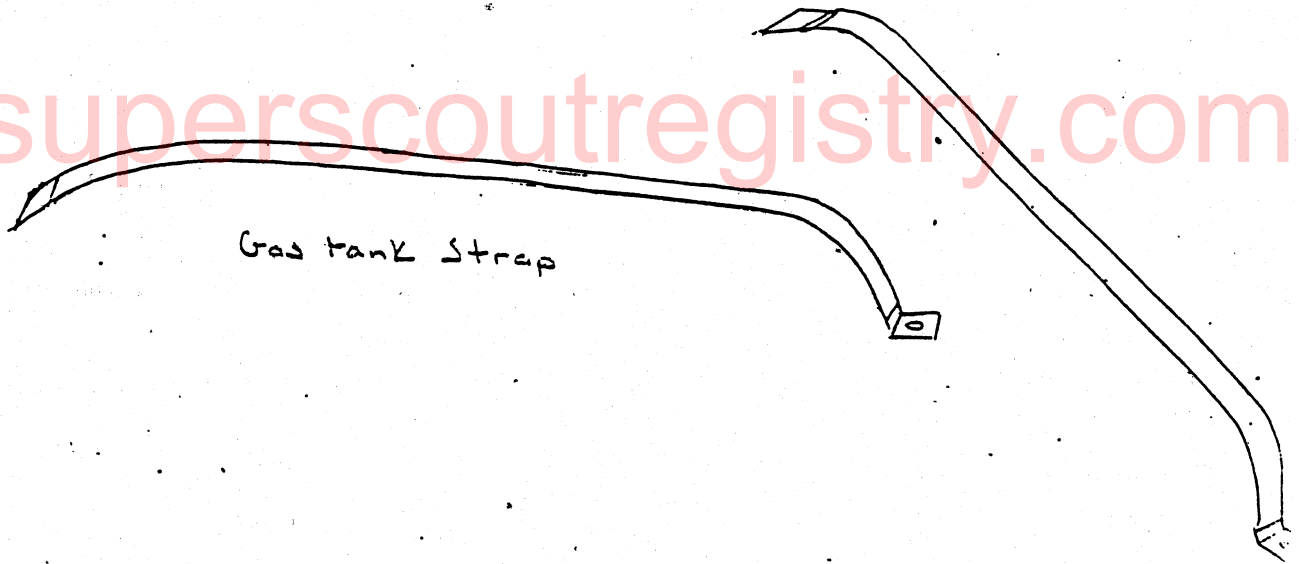

Gas tank Strap

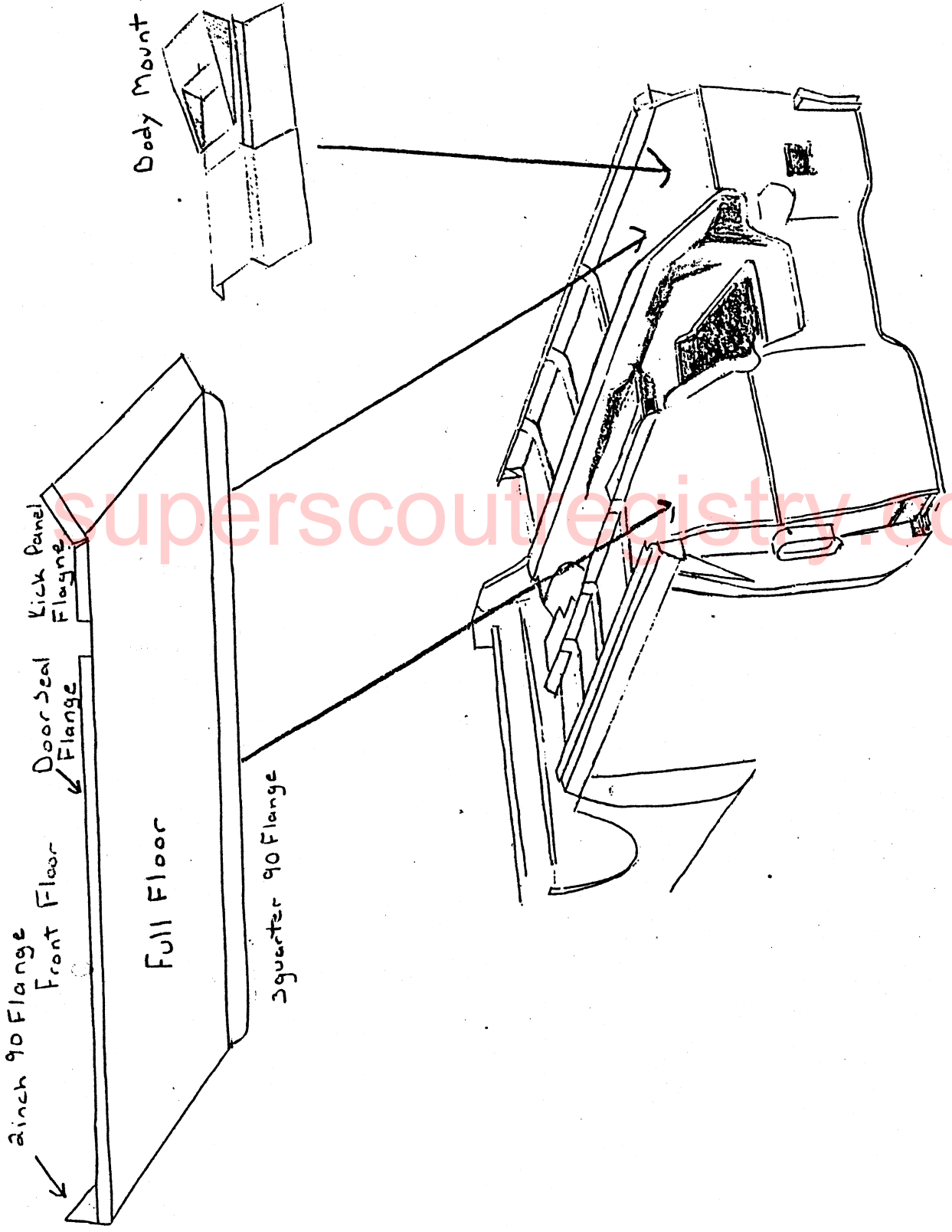

superscoutregistry.com



### Three Different Front Floors

1. App. 14" long, which covers body mount when it rust through floor.
2. It covers the complete floor with a 2" 90 turned up at the rear, has a 1/2" 90 turned up for rocker and door seal to fit into
3. Takes care of total floor, it has a 2" 90 at back, turned up. It has a 1 1/2" on inside floor to join the two floors together and it has 1/2" 90 for rocker and door seal.

Lip Maker, which takes care of the piece that is rusted out for door seal and hold's your rocker in place.

Second Body Mount that goes under body where you step up into the rear floor.

Scout Door boot. Replaces the rusted lower part of your Scout's door. Made from heavy duty metal and made to conform to the original configuration of the door. For all Scouts.

Complete line of carpet, seat upholstery and floor mats.  
Prices upon request to type of material and style of carpet.

super-scout-registry.com

Two Piece Body Mount

Inner Rocker Side

Inner Tunnel Side

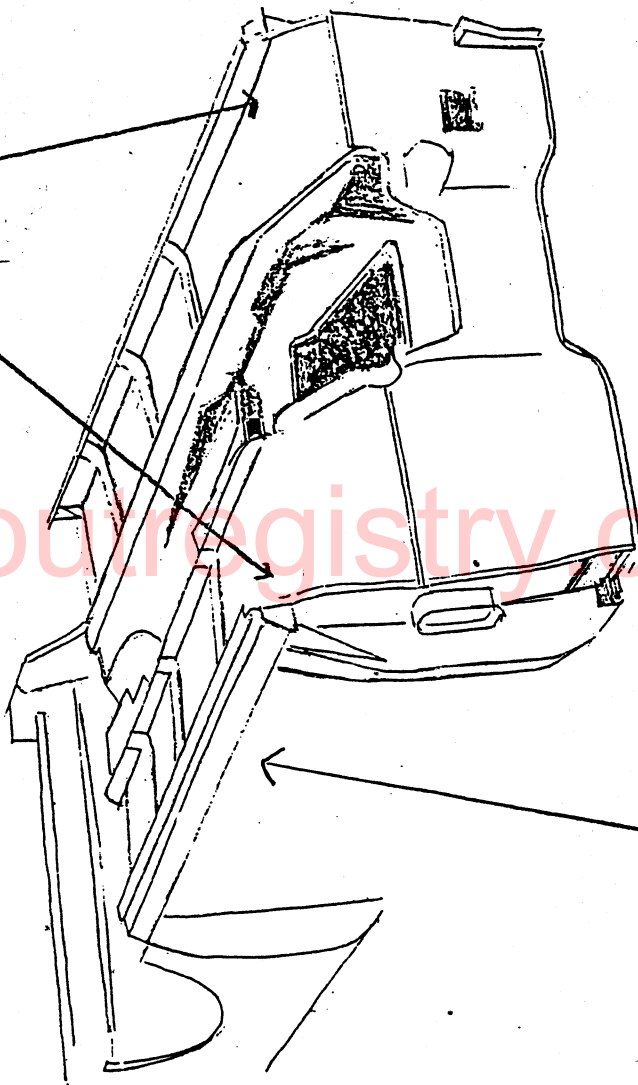

Rocker



Snaps on Door Seal Lip

Slit

Snaps around Inner Rocker

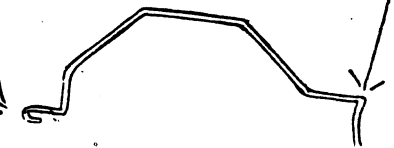

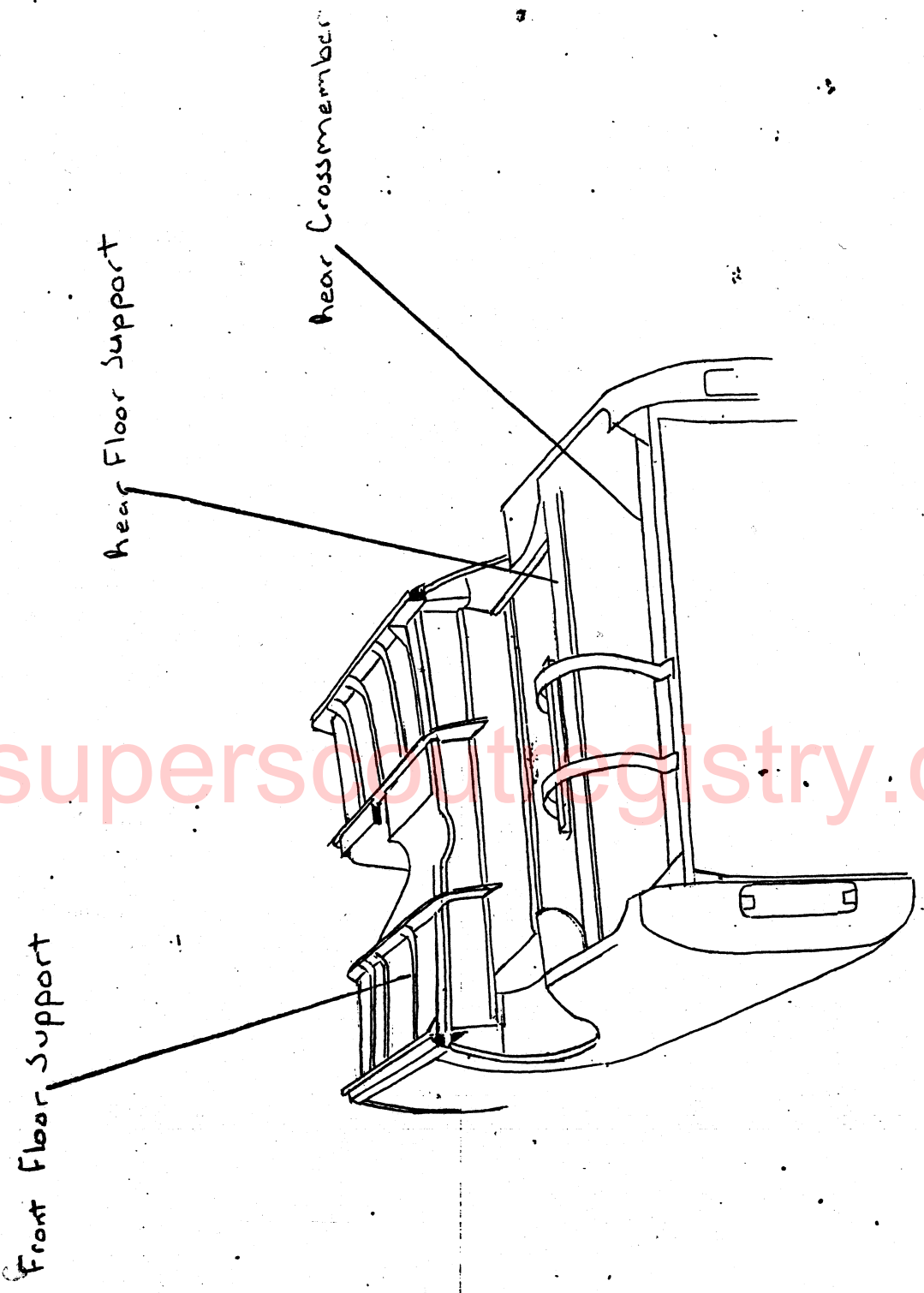

Front Floor Support

Rear Floor Support

Rear Crossmember

superscriptregistry.com

# appearance

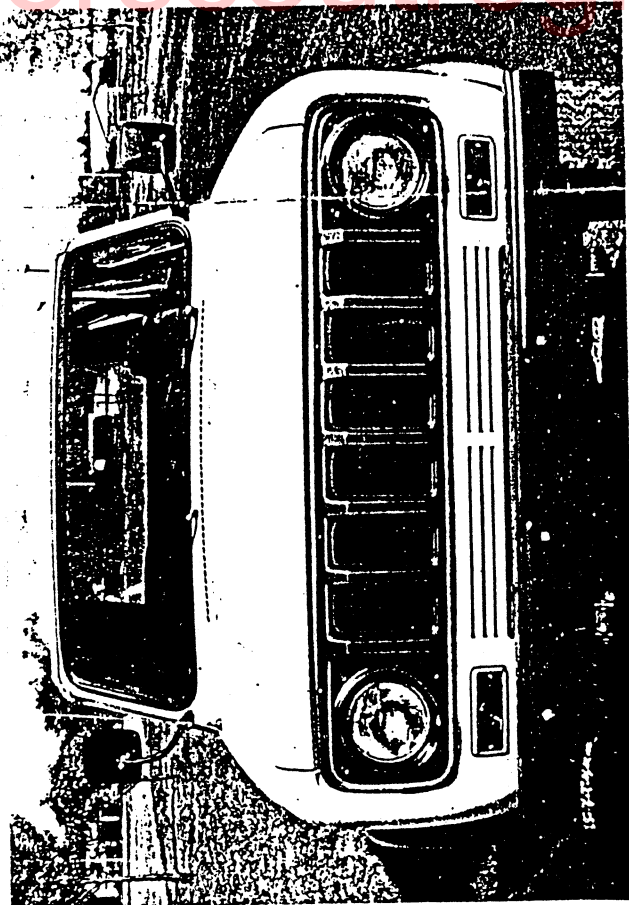

**GRILL INSERT**  
Dress up your Scout with this attractive black plastic grill insert. Fits all Scout II, Traveler, Terra, and SS II models.

Grill insert.....

2



**DOOR OPENING PANELS**  
Jazz up your Scout with these rugged, black Lexan® plastic door panels. Designed for use with the SS II Scout Convertible Top Covers.

superscoutregistry.com

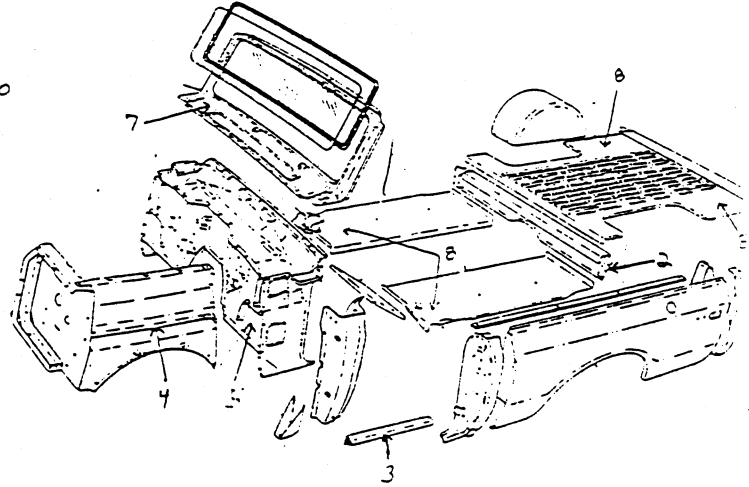
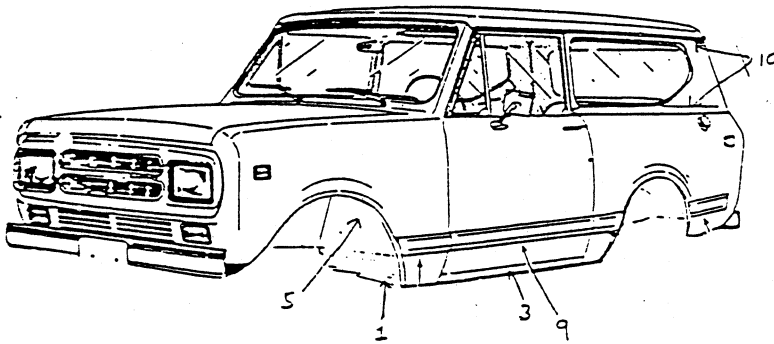

### 10 things to look for when buying a used Scout.

- 1) **FRONT BODY MOUNTS**  
This is the most common spot that rusts.
- 2) **CENTER BODY MOUNTS**  
Look in front of the rear wheels at the mounts for rust.
- 3) **ROCKERS**  
Check the inner rocker and body cross members. The outer rocker is pretty obvious and you can usually see the rust.
- 4) **FRONT INNER FENDERS**  
Check above front wheels and inside at the battery box.
- 5) **FIRE WALL**  
While you are checking the inners look behind the front wheels at the fire wall.
- 6) **REAR CROSSMEMBER**  
Check behind the rear bumper at the rear cross member.
- 7) **WINDSHIELD FRAME**  
Check outside for rust but also look at the inside at the posts.
- 8) **FLOOR BOARDS**  
Check front boards also check rear between the wheel wells and tail gate.
- 9) **DOORS**  
Check inside bottom of each door. Also check hinge area of the lift gate.
- 10) **TOP**  
Check the lower edges and at the seam of the side and roof.

When checking for rust it is a good idea to wear gloves and use a screw driver or hammer. Remember rust is sharp and can cut.

The Front Cab Mounts are replacements for the mounts behind the front wheels. They extend from the tunnel to the rocker panels, with flanges for welding on both ends. They extend 7" up the angled part of the floorboard and are 5" wide under the floor with a 1" formed box section like the original mount. There is a separate box gusset that welds to the rocker panel and extends in to the rubber cab mount.

The Full Floors are 17" wide, extend from 5 inches up on the angled part of the firewall back to the step behind the seat and have a new lip for the seal under the door. The Short Floors cover only the front 13 inches of the floor and are also 17" wide.

The Lipmaker is a 1/2" wide panel for along the outer edge of the floor with a flange to make a new seal lip under the door.

The Tailgate Pillar and Gussets are the panels inside the tailgate opening where the latch striker mounts and the gusset is the small panel forming the rear of the interior, extending from the tailgate out into the quarter panels.

The Rear Wheel Front Gussets are the 6x8" triangular panels below the wheel well above the end of the rocker panels at the front of the rear wheels.

The Rear Quarter Filler panel is a splash panel to fill the open area of the rear fenders behind the rear wheels. A similar panel was incorporated into the 1980 Scout production.

The Rear Quarter Panels are of one piece construction, including the end cap. They are installed by cutting off all of the original fender and pop-riveting them on along the edges. With experience and an air chisel to remove the old fenders, installation can be made in a day's time.

The Front Fenders are a bolt-on duplicate of the original, with slight modifications to provide better fit of the thicker fiberglass.

The SS II Door Filler Panels are a duplicate of the OEM black panels, but of white fiberglass and are somewhat stiffer. They pop-rivet on just as the originals do. A pair consists of 4 pieces, an inner and an outer for both the left and right sides.

[superscoutregistry.com](http://superscoutregistry.com)