

Building a UV Exposure Unit with LED lights

Introduction

About 5 years ago I built my first UV Exposure Unit using 24" UV florescent lights. The first mistake on that unit was that I figured I should be able to print 16x20. Wrong! First of all, I built the unit before I bought the contact print frames. The 16x20 frame did not fit. The width was fine but the depth was not. So, I cut out the back. The next problem was that the florescent bulbs don't emit as much UV at the ends as in the middle. I then rebuilt the unit taller and that reduce the issue, but not completely. The unit is now about 5 years old, one light is failing and the others are not putting out as much UV as they used to. I have been thinking I would like to print larger than 16x20, but my darkroom does not have room for a UV Exposure Unit using 48" florescent bulbs. So I began researching LED lights mounted on strips that can be cut to length. I decided to build a unit that could handle up to 24x36.

Building the large Contact Print Frame first

My original contact frames (8x10, 11x14 and 16x20) were built by Doug Kennedy, so I emailed him about building a 24 x 36 frame. I did not get a response. Therefore, I built my own. It is a very minimalist design. The image height is the same as my other contact frames.

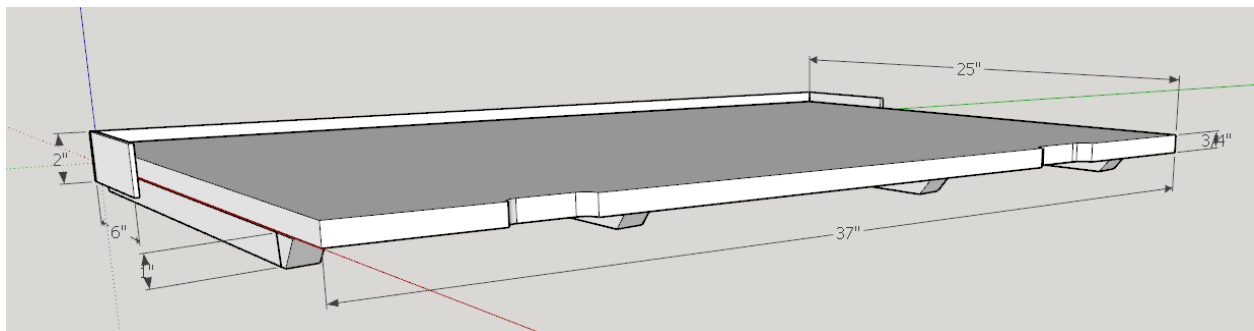

I bought a piece of 3/16" crystal glass (25x37) to place on the top felt surface.



Cardboard Cover to protect Glass



Glass tilt up for placement of paper and negative



Glass down to cover paper and negative

Purchasing the UV LED Strips

In my research of UV LEDs, I found a wide range of LEDs and prices. Most UV LEDs are used in black light settings or for screen printing exposure units. Most sellers had a tremendous lack on technical information. The one exception was www.WaveformLighting.com. Their products are very expensive, but from reading through their website, it was clear the quality of their hardware was excellent. The following list is what I purchased:

realUV LED Strip Lights (365nm)	5 meter	2 rolls	@ \$195 ea.
FilmGrade DC Power Supply for LED		2 units	@ \$49 ea.
PN 3071 LED Strip to Strip Solderless Connectors		1 pack of 10	@ \$18
PN 7094 Female DC Barrel Jack Plug		1 pack of 4	@ \$8.95

Beginning the UV Exposure Unit build

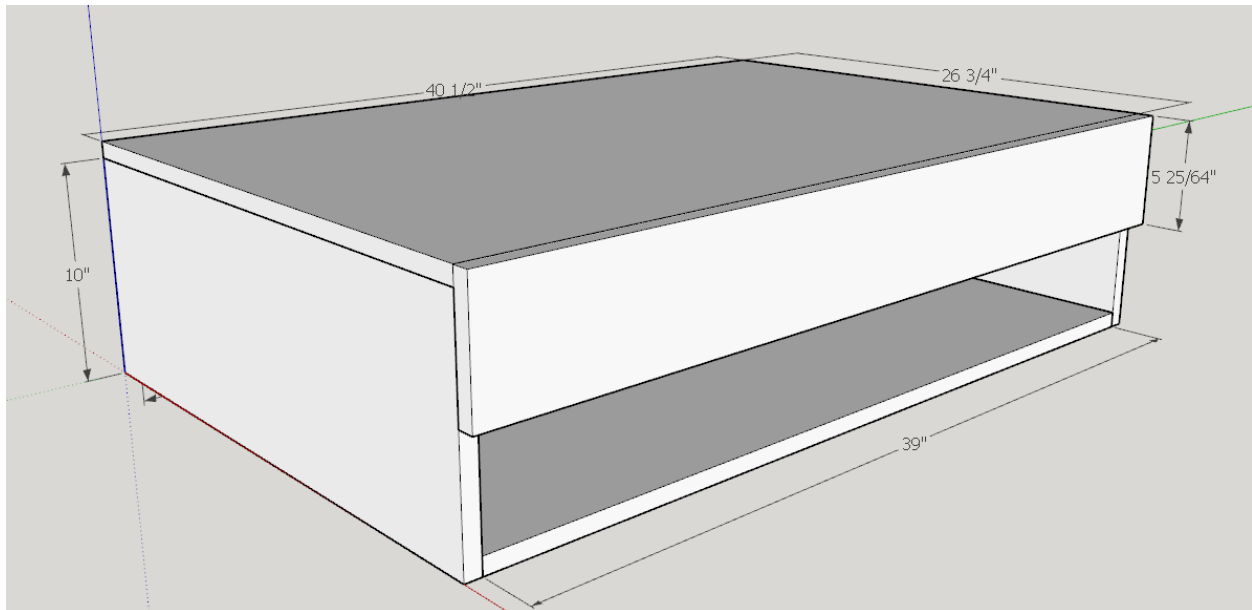

I started by cutting only the bottom and the light panel. My calculations gave me a gap between LED strips of $2 \frac{1}{8}$ " and I was concerned that if the sides of the Unit were too short, that I may get banding in the print. So, I did a temporary install of 5 strips of LEDs on the light panel using double stick tape and not the self-adhesive on the strips. I made up temporary sides with adjustable shelf pin holes so I could test the design. To drill the holes, I used a Rockler jig for the placement of the holes. I drilled 11 sets of holes ($3 \frac{1}{8}$ ", $4 \frac{3}{8}$ ", $5 \frac{5}{8}$ ", $6 \frac{7}{8}$ ", $8 \frac{1}{8}$ ", $9 \frac{3}{8}$ ", $10 \frac{5}{8}$ ", $11 \frac{7}{8}$ ", $12 \frac{3}{8}$ ", $13 \frac{5}{8}$ ", and $14 \frac{7}{8}$ "). For testing I started with the light panel in the sixth hole setting ($9 \frac{3}{8}$ "). I did a test strip running in line with the LED strips and determine MaxD was 10 minutes. Then I printed a second piece of paper turned 90° to the LED strips. No banding was present. I repeated this test procedure at the 4th hole level (6



7/8") and 2nd hole level 4 3/8". At the 4th hole level, MaxD was 9 minutes and at the 2nd hole level it was 8 minutes. At both of these levels there was no banding. I was concerned that at the 2nd hole level there could be a clearance issue where I could clip the LEDs when putting the contact frame into the Unit. So, I shifted the light panel up to the 3rd hole level and tested again.

Testing UV Unit

Finishing the UV Exposure Unit box

With testing complete, I determined that the sides and back should be 10" tall. I drilled the 3rd, 4th and 5th holes in the sides so that I could still make adjustments after the box was complete. I completed the box construction, painted all parts and put it together. The sides and back are attached using Kreg Jig pocket screws without glue.



Wiring the Light Panel



I carefully lined out the placement of the LED strips and drilled hole for the wires to pass to the top side of the light panel. I installed all ten LED strips using the self-adhesive. The pack of LED Strip to Strip Solderless Connectors had 10 pieces. I cut these in half giving me 20 connectors. When installing each connector, I found I needed to peel back the red protective covering of the self-adhesive and the self-adhesive to fit the strip into the connector and make connection to the contacts in the connector. These contacts are quite fragile and when splitting the red and black wires apart, I broke one contact. I was able to solder it back together. Also, the connectors have two ways to be installed. I chose to always have the red wire connect to the + side of the strip.

In my research, I read that over a 5 meter length of strip lights, there is a voltage drop. I was concerned that this aspect may provide uneven UV light. So I planned to power every other strip from one side of the panel and the remaining strips from the other. Also to hopefully reduce voltage drop, I would wire each strip in parallel. I ran this idea past both my brother and brother-in-law, both of whom have more experience in this than I do. The only suggestion to alter my plan was to connect to both ends of each strip. The wiring connections are soldered and covered with heat shrink. The wiring is stapled into place and plastic wire ties are used to anchor the transformers and barrel connectors. The two transformers will be plugged into the extension cord shown notched into the back right corner of the box on the previous page.



Half of the wiring complete

Installing the access cloth



I used some denim like cloth that passed a little light. I sewed it double thickness and longer than the width of the unit. At the bottom of the flap is a pocket containing a length very heavy gage Romex. The flap is long enough so that the flap can be raised up and the weighted edge sits on the top of the unit so it is out of the way when putting the contact frame into the unit. To hinge the cloth, I used a length of "U" shaped adjustable shelf rail, screwing through it and the cloth in into the face piece. The top and face pieces are screwed to the sides and/or back so these parts can be removed for maintenance.

The light panel was installed in the middle adjustment hole and the face plate is long enough to cover the light panel if I choose to use the lower adjustment holes.

Final Install in my Darkroom



The print dryer sits on top of the UV Exposure Unit.

Les Allert

Quail Run Art

530-318-8727

www.QuailRunArt.com

QuailRunArt@gmail.com

#QuailRunArt

Quail Run Art