

# JUMONG GENERAL



## ULTIMATE CHOICE IN CONVENTIONAL SYSTEM

Enhance your workflow with vertical motor driven radiography system  
Available with a variety of options, it is capable of handling a full range of applications

## SUPERIORITY

Great expandability (film, CR, flat panel detector)  
Economic feasibility  
Convenient and compact design

CONVENTIONAL  
RAIDOGRAPHY

FLOATING  
TABLE

FLOOR RAIL  
TUBE STAND

BUCKY  
STAND

OSCILLATING  
GRID

DR  
UPGRADABLE

# SYSTEM CONFIGURATION & SPECIFICATION

\* All specifications are subject to change

		40kW	50kW
Generator	Type	Inverter type HF 200 kHz+	
	Line nominal/phase*	1 Ø 208 / 230 VAC (125 kV) standard	3 Ø 400 / 480 VAC (150 kV) standard
		3 Ø 400 / 480 VAC (125 kV) standard	
	High voltage ripple(typ.)	<1 kV @ 100 kV	
	kV range	40 ~ 125 kV	
	mA range	10 ~ 500mA	10 ~ 630mA
mAs range	0.1 ~ 500mAs	0.1 ~ 630mAs	
Tube	Type	Rotating Anode	
	Maximum voltage	125 kV	150 kV
	Focal spot	Small : 1.0 mm / Large : 2.0 mm	Small : 0.6 mm / Large : 1.2 mm
	Anode target angle	16 °	12 °
	Anode heat capacity	140 kHu	300 kHu
Collimator	Power supply	1Ø 24VAC 50/60Hz	
	Related tube voltage	125 kV	
	Filters	1.2mm Al	
	Intensity of illumination	LED over 160 lux	
Floor rail tube stand	Height	2,300 mm	
	Floor rail width	3,150 mm	
	Vertical movement	400 ~ 1,790 mm (motorized)	
	Horizontal movement	2,080 mm (manual)	
	Tube rotation	±180 ° (Catch point at ±90 °)	
Wall stand	Height	2,100 mm	
	Vertical movement	420 ~ 1,730 mm	
Table	Length	2,010 mm	
	Width	795 mm	
	Height from the floor	705 mm	
	Patient load capacity	350 kg	
	Longitudinal travel	265 mm	
	Transverse travel	± 550 mm	

• UPGRADE AND OPTIONS : AEC Ion chamber interface | DAP interface | PSU (Capacitor bank 200/500)

## PACKING INFORMATION

Weight	165 kg	230 kg	240 kg	150 kg	250 kg
Dimension	1,060 x 910 x 1,400	2,200 x 745 x 760	2,360 x 610 x 760	3,020 x 420 x 360	2,100 x 850 x 930

## TECHNICAL DRAWING

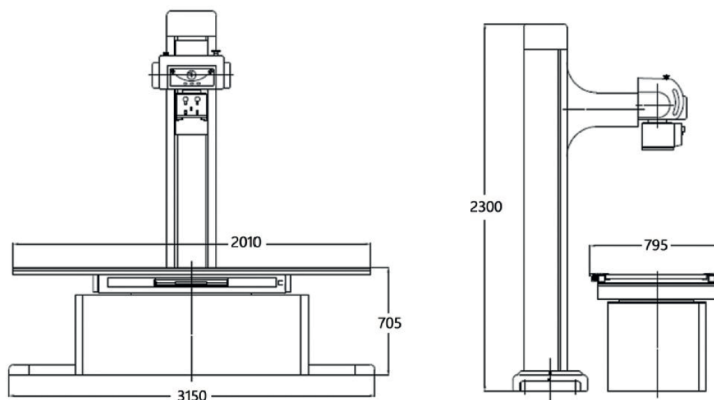

HQ: 113 Jungdae-Ro, Songpa-Gu, Seoul 05718, KOREA | Factory: 10, Yangnyeong-ro, Moga-myeon, Icheon-Si, Gyeonggi-Do, KOREA

US Office: 4801 Wilshire Blvd, Ste. 104 Los Angeles, CA 90010, USA | P +82 (0)2 449 6908 / +82 (0)2 449 6909 | E sales@sghealthcare.com | H www.sghealthcare.com