

JUMONG S

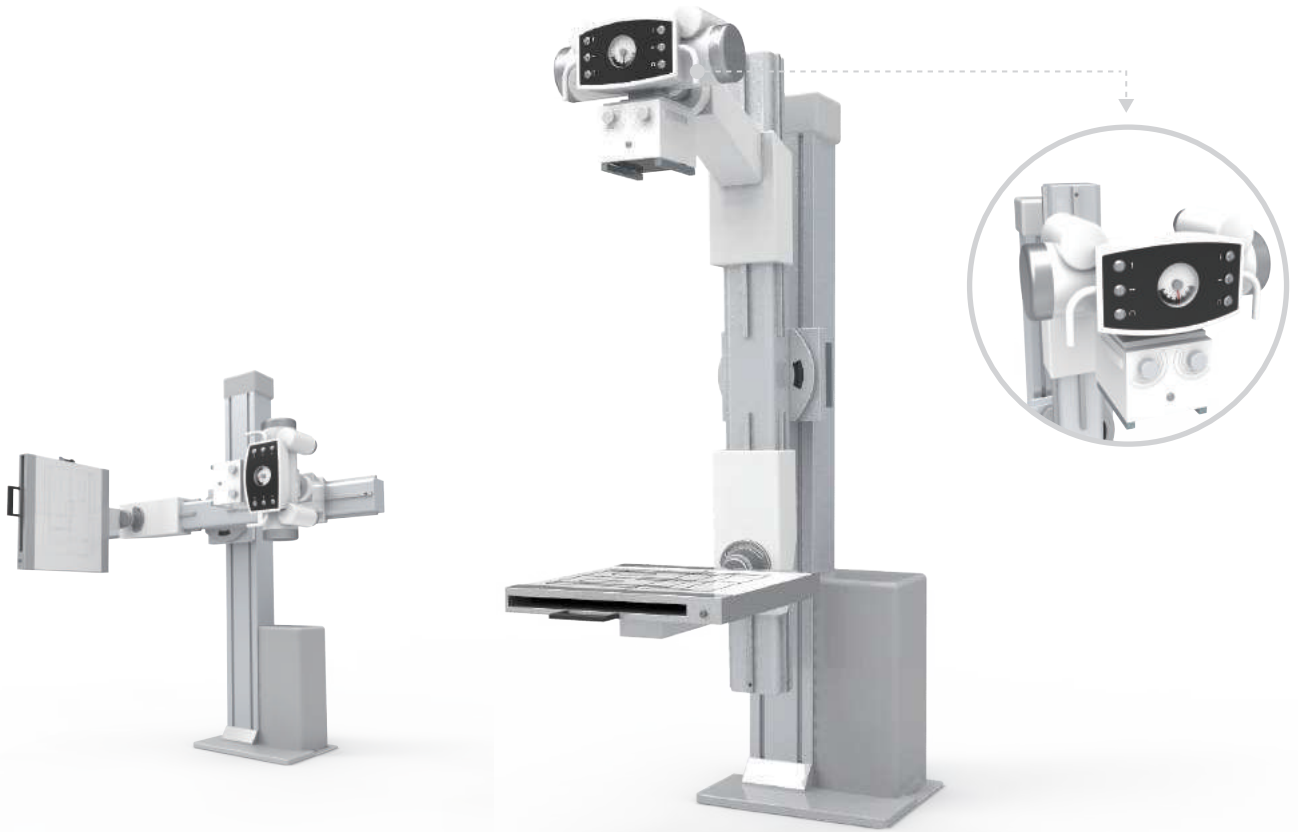

Compact System for More

Digital diagnostic radiography system with a compact straight arm for limited space
High frequency X-ray generator and high quality X-ray output, giving you a high definition images

Single panel multi-purpose straight arm system provides a cost effective
ergonomic solution for the entire range of radiographic examinations

Improvement in speed by stabilizing and optimizing positioning on the straight arm



CONVENTIONAL
RADIOGRAPHY



DIGITAL
RADIOGRAPHY



MOBILE
TABLE



UNIVERSAL
STAND

SYSTEM CONFIGURATION & SPECIFICATION

		40kw	50kw
Generator	Input Power	1Ø 230VAC 3Ø 380VAC	3Ø 380VAC
	kV Range	40 - 150kV	
	Output Frequency	450kHz	
	mAs Range	0.1 -1000mA	
	Tube Current Range	10-500mA	10-630mA
	Exposure time Range	1.0 -6300ms	
	Tube Calibration	Automatic	
	Anode Rotation Drive	Low / Dual Speed Starter	
	Console	Mini Console	
Tube	Type	Toshiba E7239X	Toshiba E7252X
	Focal Spot	1.0 - 2.0	0.6 - 1.2
	Operating Voltage	40 - 125kV	40 - 150 kV
	Anode Heat Capacity	140kHU	300kHU
	Target Angle	16°	12°
Collimator	Power Supply	1Ø 24VAC 50/60Hz	1Ø 24VAC 50/60Hz
	Related Tube Voltage	125 kvp	125 kvp
	Filters	1.2mm Al	1.2mm Al
	Intensity of Illumination	LED over 160 lux	LED over 160 lux
GRID		103L 10:1 150cm	
HVC		10m	
Tube Stand	Heights	2150mm	
	SID Movement (Motorized)	1110 mm - 1926mm	
	Vertical Movement (Motorized)	1700 mm	
	Arm Rotation	+120°/ -30°	
	Tube Head Rotation	±90°	
	Bucky Tilting	±45°	
Mobile Table	Weight Capacity	220 kg	
	Table Size	728W) x 1973mm(L) x 700mm(H)	
	Top Filtration	1.2 Al equivalent	

- UPGRADE AND OPTIONS : AEC Ion chamber Interface | DAP Interface

PACKING INFORMATION

Weight	420kg	660kg
Dimension	2310x770x1470mm	1360x1460x1150mm

TECHNICAL DRAWING

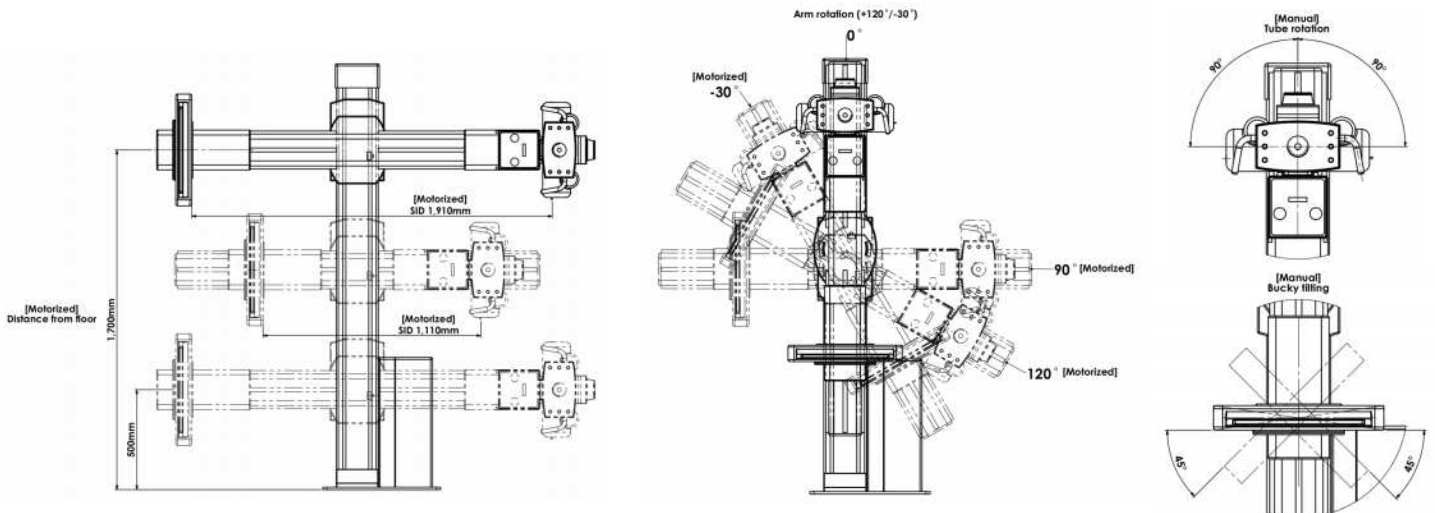

HQ: 113 Jungdae-ro, Songpa-Gu, Seoul 05718, KOREA | Factory: 10, Yangnyeong-ro, Moga-myeon, Icheon-Si, Gyeonggi-Do, KOREA

US Office: 4801 Wilshire Blvd, Ste. 104 Los Angeles, CA 90010, USA | P +82 (0)2 449 6908 / +82 (0)2 449 6909 | E sales@sghealthcare.com | H www.sghealthcare.com