



OF150A

Oceanflo.co.nz

INTRODUCTION

Congratulations on purchasing an Oceanflo Watermaker. All units are fully bench-tested and delivered with Pride. Your Watermaker will provide you with clean and safe drinking water for many years to come. To ensure trouble-free performance please follow the simple instructions in this owners' guide. By understanding the function/ importance and normal operation of each part in the system/ the operator can readily diagnose problems when they first develop. Such problems are easily corrected and require minor adjustments. If left unattended/ a minor problem in one component may affect the rest of the system and can lead to your unit needing repair. If you have any questions regarding the installation/ operation or maintenance of your Watermaker, please contact your Dealer.

SPECIFICATIONS

Reverse Osmosis performance varies with the feed water temperature, voltage and salinity.

The rated performance is tested at 26C / 80F water temperature and 33g NaCl/ltr.

Rated performance: 150 LPH @ 13 vdc.

RO Membrane Type: Standard size high rejection TFC Polyamide/ thin film composite/ spiral wound, single pass reverse osmosis element.

Product Water Quality: Minimum 500 ppm TDS

Feed Water Salinity Range: Up to 50,000 ppm TDS

Chlorine Tolerance: 1000 hours @ 0.1 PPM

Feed Water Pressure: 3 psi to 60 psi

Operating Pressure: 600 to 850 psi

Feed Water Temperature Range: min. 50F / 10C/ max 113F / 45C

ELECTRICAL POWER REQUIREMENTS

Voltage	12	24
Running Amps Approx	45	22
Circuit Breaker Size	60	30

STANDARD SYSTEM COMPONENTS

1. High-efficiency self-pressure regulating pump and motor.
2. Dual Carbon fiber pressure vessels with dual membranes.
3. Jumbo5 micron pre filter housing assembly.
4. Powder coated control panel with salinity control.
5. High output dual impeller brushless mag drive boost pump.
6. Remote control Panel.
7. Fresh water flush with carbon filter and solenoid valve Assembly.
8. Product water filter Assembly.



INSTALLATION INSTRUCTIONS

Install the plumbing according to the provided diagrams, following the notes below. Standard hoses and fittings are not included as they will differ depending on the boat.

Pump and motor assembly.

Mount the pump and motor assembly on a flat surface. It is advisable to have the pump in a well-ventilated area that does not get too hot, this will extend the motor life.

Note: It is normal for the motor to reach temperatures of 70 degrees Celsius.

Pre-Filters

Install the pre-filter assembly in an accessible area away from equipment to avoid water damage during filter changes.

Saltwater supply lines *(19mm and 16mm Pressure flex not supplied)*

Thru-Hull and strainer *(not supplied)*

The designated intake thru-hull fitting of the boat should be positioned in an area that remains submerged under normal operating conditions. A strainer scoop thru-hull fitting, installed with the opening facing forward, can be beneficial as it typically generates a small amount of pressure while the boat is in motion. Drilling a small hole in the back of the scoop will facilitate the escape of air when underway. It is crucial not to place the thru-hull fitting directly in front of a speedometer pickup. Additionally, it is advisable to avoid positioning the intake thru-hull fitting immediately aft of the output from the holding tank, head, or galley sink overboard discharge.

STEP 1
Plumb the salt water lines as per diagram below.
Connections can be taken from either side of the pump.
 $\frac{5}{8}$ " or 16mm and $\frac{3}{4}$ " or 19mm pressure flex is used.

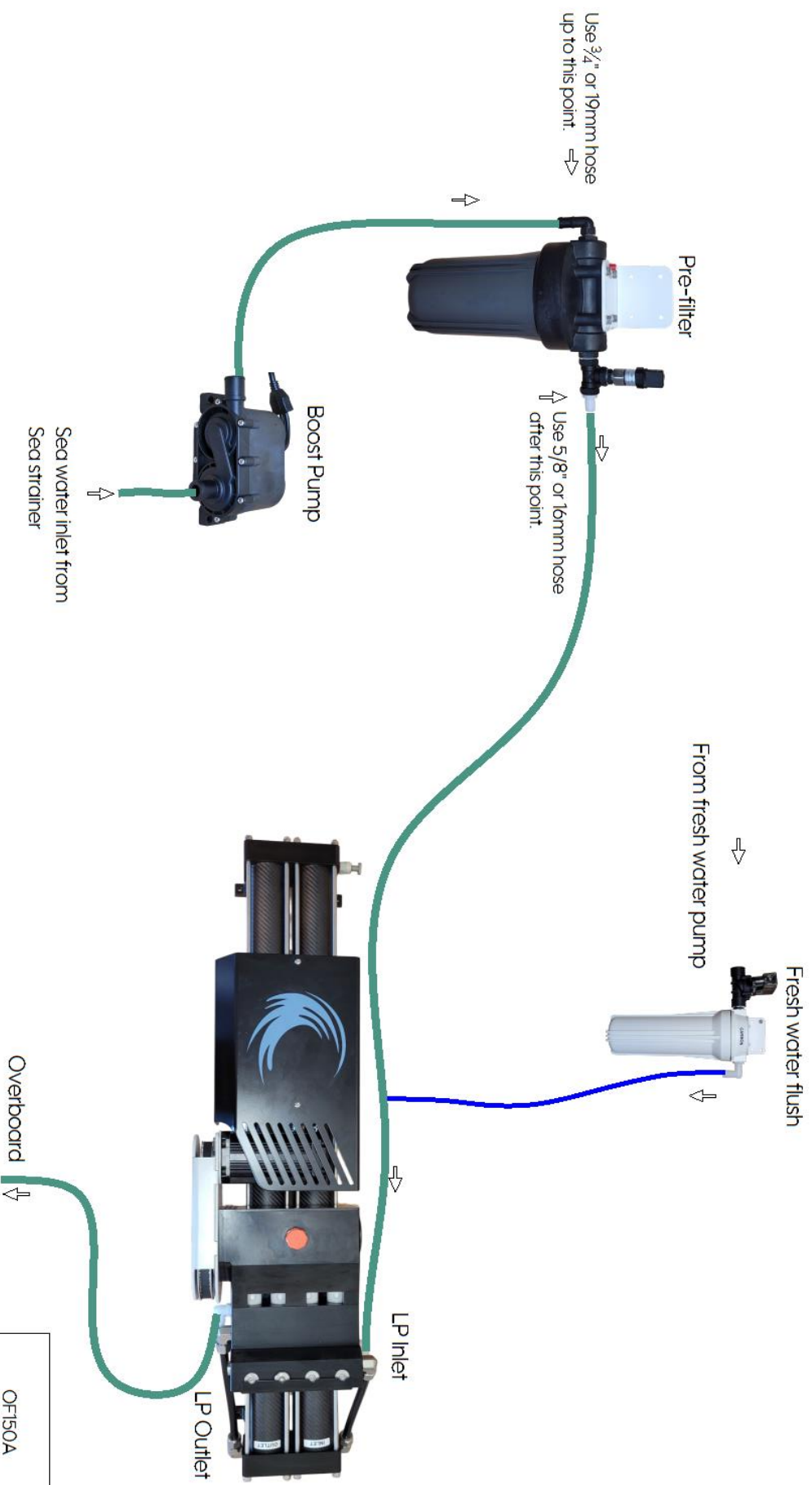

OFT50A
Oceanflo

STEP 2

Instal the high pressure line as per diagram below. This 1/4 black high pressure line connects the HP gauge to the remaining HP pump outlet on the pump.

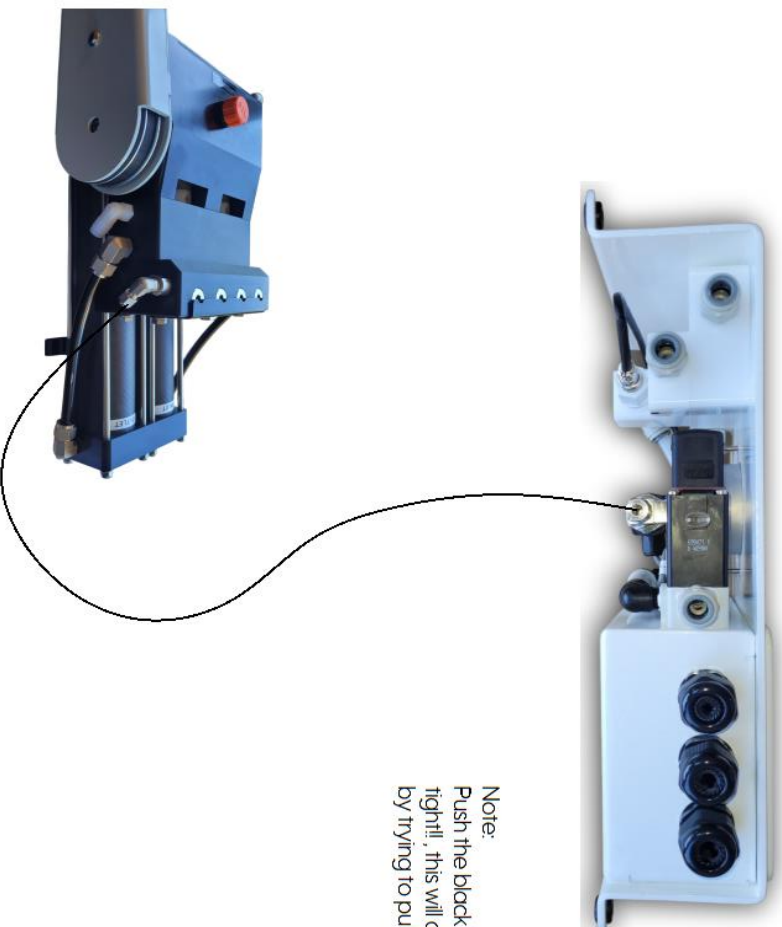

Note:
Push the black hose all the way in to the fitting. Do up the nut tight!!; this will compress the olive. Ensure the nut is tight enough by trying to pull the black line out from the fitting.

STEP 3

Install the 3/8 clear tube as per diagram below.

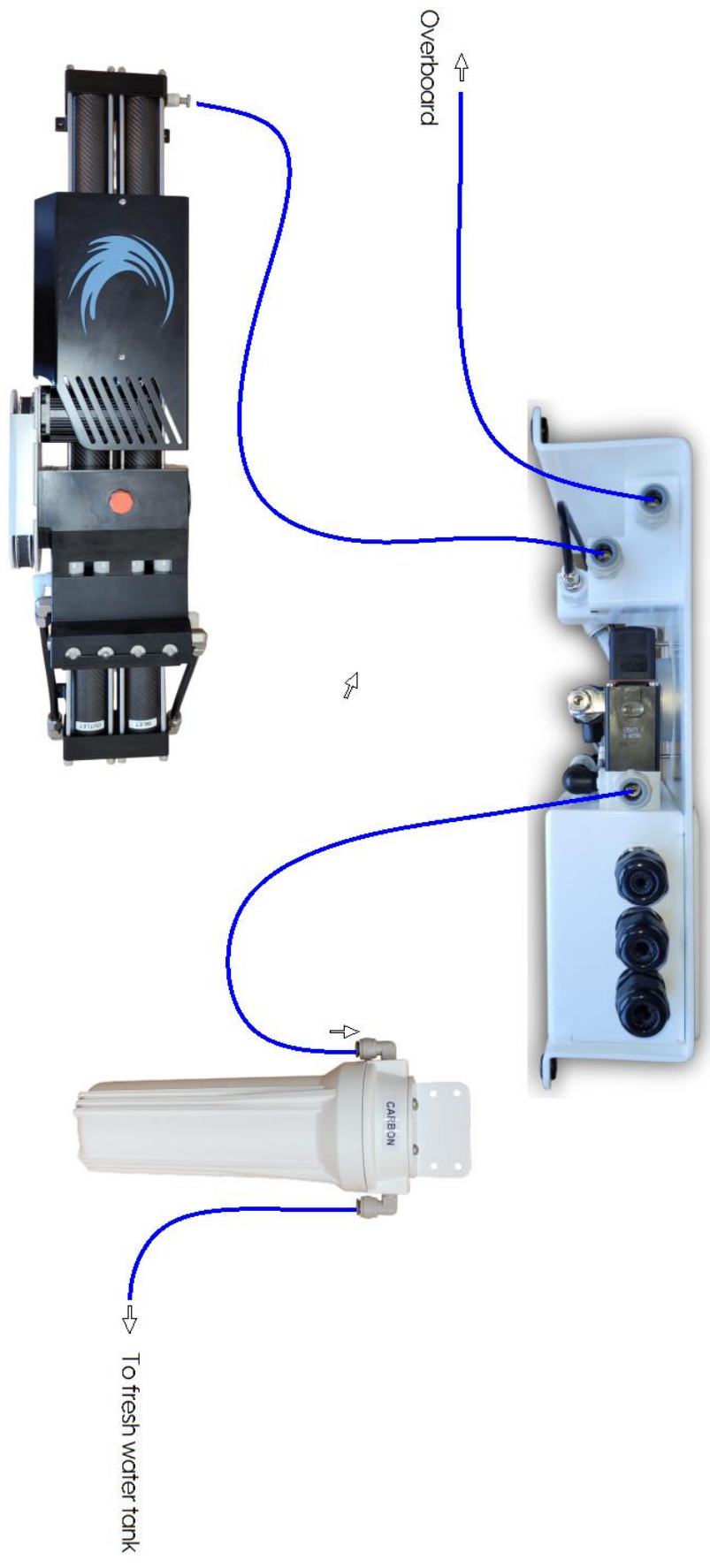

OF150A
Oceanflo

ELECTRICAL

Wiring the components

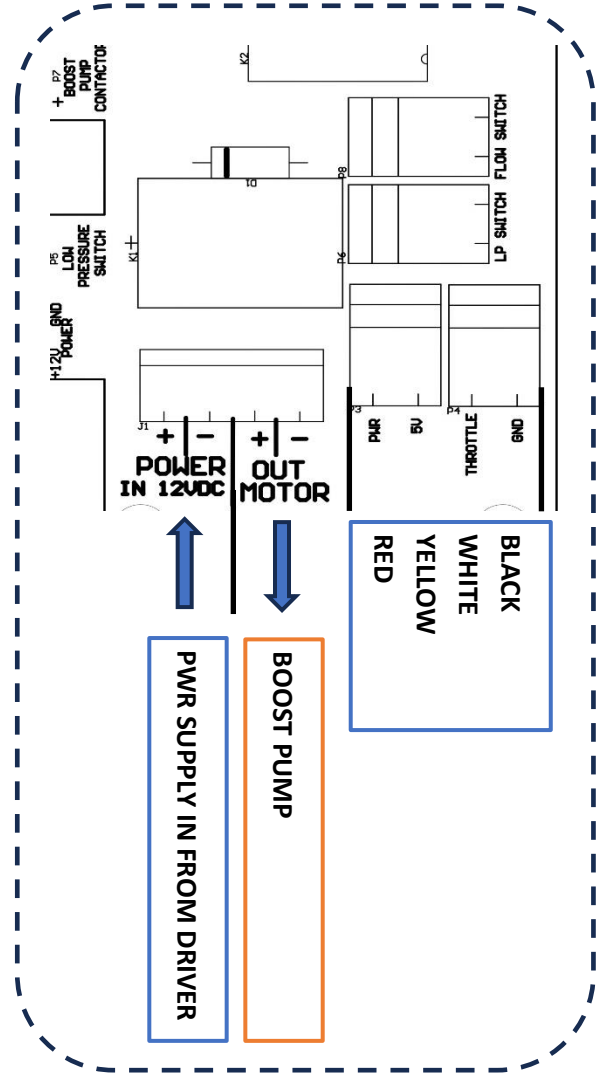
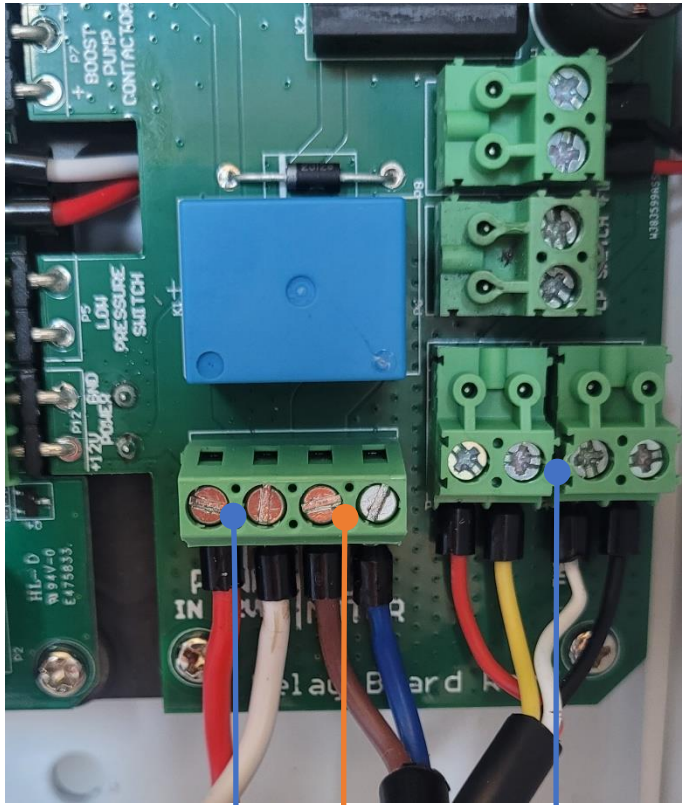

BOOST PUMP

DRIVER CONTROLLER

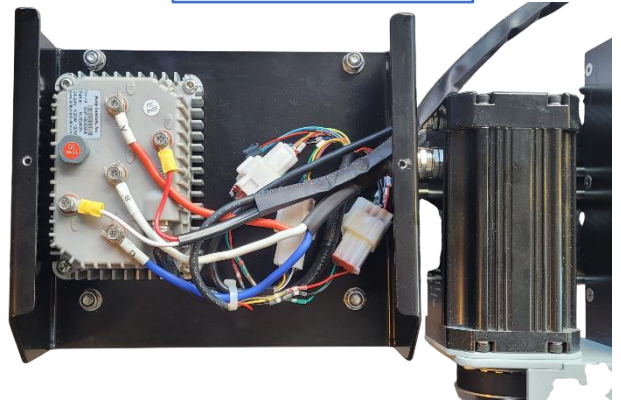

Pre Filter and Fresh water flush Filter

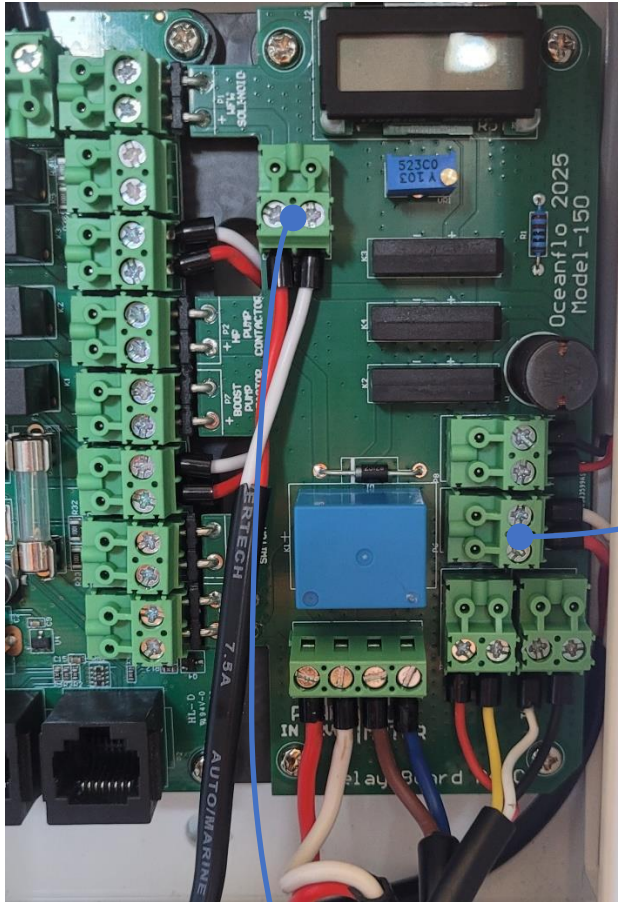

PRE FILTER



FWF FILTER



POWER SUPPLY

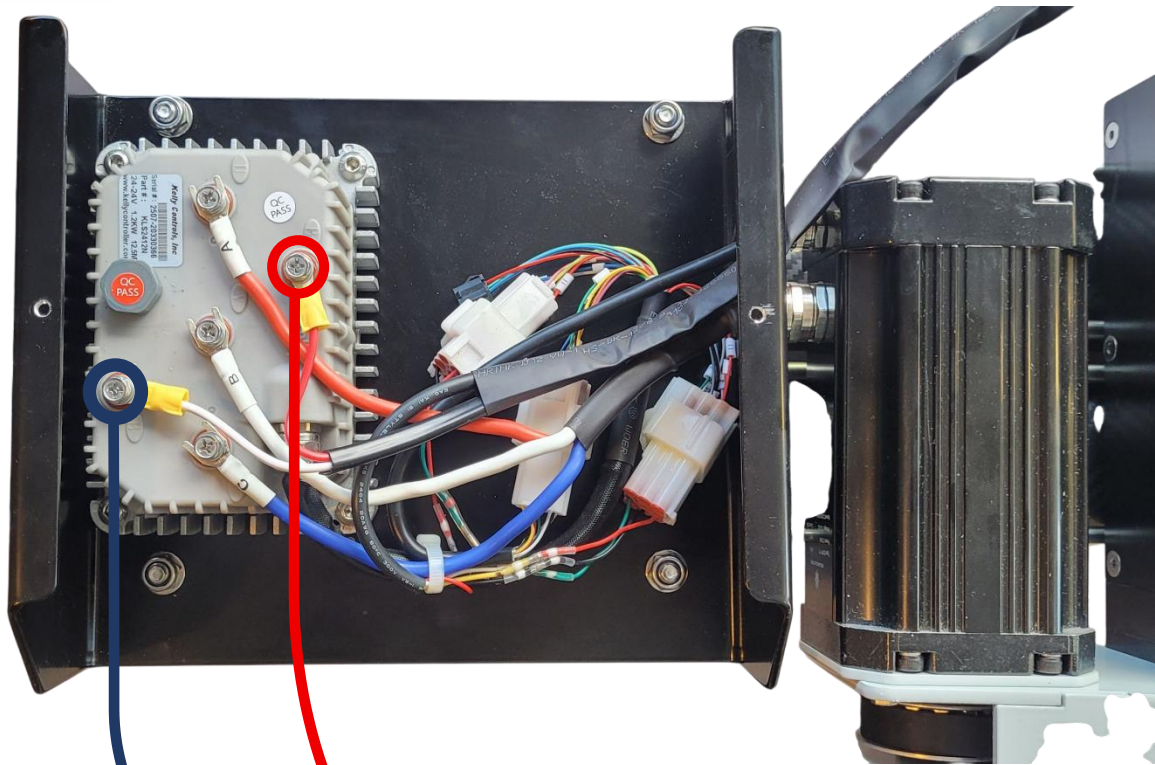

+
-

Power Supply from Circuit Breaker
60 Amp Breaker on 12 VDC Supply
30 Amp Breaker on 24 VDC Supply

Minimum Power Supply Cable Wire Size @12VDC

Lenth Of Run (M)	3	5	6	8	10	12	15
Wire Size (AWG)	6	6	4	4	2	2	1
Wire Size (mm2)	16	16	25	25	35	35	50

Minimum Power Supply Cable Wire Size @24VDC

Lenth Of Run (M)	3	5	6	8	10	12	15
Wire Size (AWG)	10	8	6	6	6	4	4
Wire Size (mm2)	6	10	16	16	16	25	25

COMMISSIONING

Before operating the Watermaker for the first time, the storage chemical in the membranes must be flushed out. This must be done under low pressure with non-chlorinated water.

1. Disconnect and remove the high-pressure fitting (black 6mm HP line) from the side of the pump.
2. Install the decompression fitting as per photo below.
3. Run the 1/8" line from the decompression fitting into a bucket.
4. Press and hold the "START" button for 4 secs. (*This starts the pump and bypasses the low-product water switch*)
5. Run for 10mins. (*This flushes the chemicals from the membranes*)
6. Remove the decompression fitting and reinstall the black 6mm HP line.
7. Again, Press and hold the "START" button for 4 secs. (*This starts the pump, but it will now build pressure, no water will be diverted to tank*)
8. Run for 10 mins. (*This will remove any storage chemical from the product water side of the membrane*)
9. Press the stop button. The flushing is complete.

Notes- Discard the first 10 mins of product water after flushing storage chemicals from the membranes. The decompression fitting is also used when storing the membranes on your Watermaker.



OPERATION

Start-up

1. Ensure the intake and overboard valve is open.
2. If it is the first time being used or there is a storage chemical in the system, ensure the commissioning procedure is followed to remove the storage chemical from the system.
3. Press the "START" button. (*See below for Indication lights*).
4. Press the "STOP" button when the required amount of water is produced.
5. If required press the "FWF" button to flush if the unit is not to be used for at least 3 days.

Flushing

Flush the Watermaker if you intend on not using it for longer than 3 days. There is no need to flush it if it is being used regularly. For the freshwater flush to work, the vessels freshwater pump must be turned on.

1. Press the freshwater flush button. (A solid blue light will come on)
2. Once the freshwater flush is complete, it will now go into its 7-day cycle indicated by a flashing blue light on the control panel.

INDICATION LIGHTS

RUNNING-Green light

- Flashing when product water is above set-point
- Solid green when product water is below set-point

FWF/TANK-Blue Light

- When running a Solid blue light indicates product water is being diverted to tank.
- When flushing a Solid blue indicates Flushing in progress while a Flashing Blue light indicates it will automatically flush every 7 days.

FAULT-Red light

- Flashing when not enough product water is produced (Low flow). If flashing for more than 10 secs it will stop the Watermaker.
- Solid Red light is a high-pressure fault and will instantly stop the Watermaker.

STOPPED-Red Light

- Solid Red when the Watermaker has been stopped via user or one of the faults.

Fault Light

There are two possible causes of a fault light.

1. The pressure has reached 950 psi as soon as this happens the unit will stop, and the fault light will be a solid red. The most likely case is the membrane has been fouled and will need replacing.
2. When there has been no product water flow detected the fault light flash for approx. 12 seconds after which the unit will stop. Blocked pre filters are the normally the cause or air has entered the system.

EMERGENCY OPERATION OPTIONS

Salinity Probe override

While running, Press and hold the FWF button for 4 secs.

This will manually divert the product water to tank overriding the salinity probe.

Manual mode- Low Flow product water switch and salinity probe override

1. Press and hold the START button for 4 secs. (*Low flow product water switch override*)
2. Press and hold the FWF button for 4 seconds (*Operates diversion valve which sends water to tank*)

Operation via Dip switches on circuit board - Caution-All safety features will be disabled!

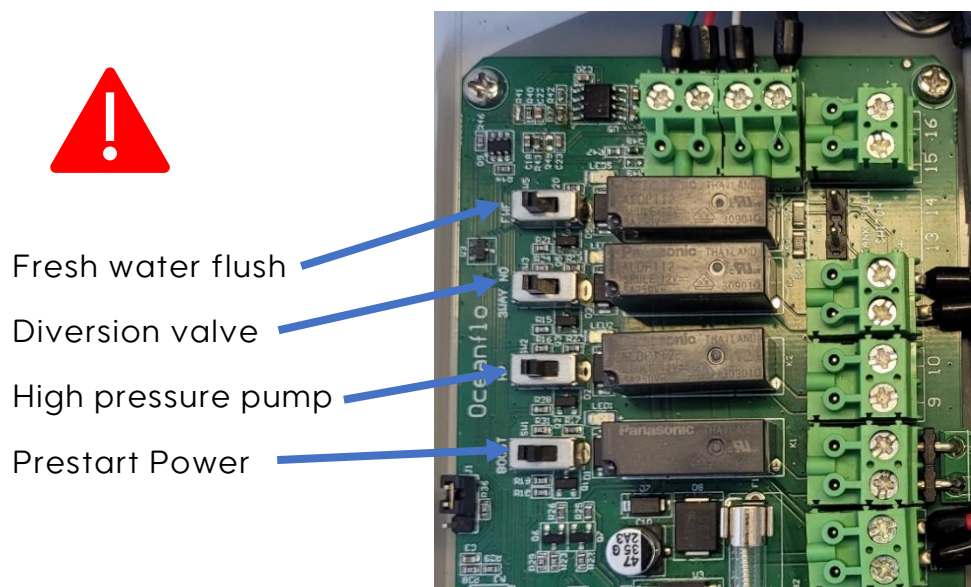

MAINTENANCE TIMETABLE

This maintenance timetable is an estimate. Adjust it based on usage frequency, intake water condition, seawater exposure, and total running time.

Component	Maintenance required	Time interval
Sea strainer	Inspect, clean screen and house	Every 100 hours or when fouled
Seawater Pre filter	Replace or clean elements	When the pump fails to build pressure and is noisy in operation
Carbon filters	Replace elements	Every six months
High pressure pump	Replace the crankcase oil	After the first 50hrs then every 500 hrs. ISO68 weight hydraulic oil is used. 0.6L 15-20mm from top of crankcase
High pressure pump	Change HP seals	When the pump fails to build sufficient pressure
Membranes	Flush with non-chlorinated water	Every week

Belt Tension

If the belt is too tight, it will become noisy and cause excessive bearing wear. The belt deflection when pressed should be 5-10mm as pictured.



ADJUSTMENTS

Salinity Setpoint

Adjustable from 200 to 800PPM

Fresh water flush time

Adjustable from 30 seconds to 3 mins.

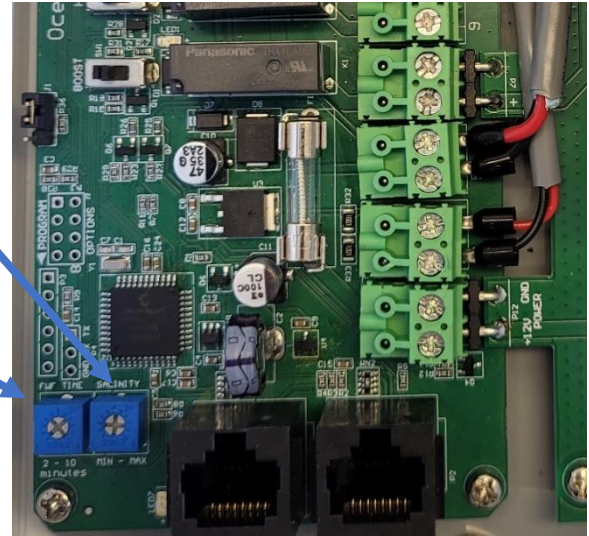

Fresh water flush Pump Speed

Adjust so the freshwater pump can keep up with supply.
(Anti clockwise slows the pump down)



FILTERS

Seawater intake filter 5 Micron (Red)

5 Micron Pleated Sediment filter 10" Long x 4.5" OD

To be changed when the pump fails to build pressure, or the HP is noisy in operation.

Carbon filter (For both the flush and product water)

5 Micron Carbon Block Filter 10" Long x 2.5" OD

To be changed every 6 months.



5 Micron Pleated Sediment



5 Micron Carbon Block

STORING

If the Watermaker needs to be stored for an extended time (3 months plus), storage chemicals must be used (PPG). This must be done under low pressure with non-chlorinated water. Only Propylene Glycol (PPG) is used.

1. Isolate sea intake.
2. Perform at least 2 freshwater flushes to remove all sea water from the system.
3. Remove the high-pressure gauge and install the decompression fitting as pictured.



4. Mix 3L of non-chlorinated water and 3L of PPG in a bucket.
5. Put the Intake, Brine outlet and decompression fitting hose in the bucket.
6. Press and hold "START" for 4 secs and run for 1 minute. This will circulate the PPG through the system and result in approx. 35% PPG concentration.
7. Following the commissioning process to re-commission the water maker and replace all the filters.

Notes



Storage chemicals: Under no circumstances should **sodium metabisulphite** be used in the pump. This may lead to irreversible damage to the pump internals. Always use food grade Propylene Glycol (PPG) with no Ethyl Alcohol at 33% or greater concentration.

Problem	Cause	Solution
Inability to build up pressure	<ul style="list-style-type: none"> -Air in the system -Blocked prefilters -Seals and pump failed -Non return valves in pump jammed 	<p>Allow more time to prime.</p> <p>Replace or clean filters.</p> <p>Replace seals.</p> <p>Remove and inspect 8 non-Return valves in pump</p>
Product output below specification	<ul style="list-style-type: none"> -Low voltage -Blocked prefilters -Worn pump seals -Non return valves fouled/obstruction 	<p>Charge batteries</p> <p>Replace or clean filters.</p> <p>Replace HP seals.</p> <p>Remove and inspect 8 non-Return valves in pump</p>
High product water salinity	<ul style="list-style-type: none"> -Membrane has reached its service life. -High seawater temperature 	<p>Replace the membranes.</p> <p>This is normal</p>
High Operating Pressure	<ul style="list-style-type: none"> -Membrane Fouling -Worn Piston seals -Very cold Sea temp 	<p>Replace Membranes</p> <p>Replace Piston seals</p> <p>This is normal</p>

NOTES

Effects of voltage: With an increase in voltage the pump will increase in speed drawing more current and producing more water with a decrease in voltage the pump will slow in speed and draw less current and produce less water. 150 liters per hour is calculated at a voltage of 13 Volts DC.

Effects of water temperature: A increase in water temperature will result in a decrease in pressure and slight decrease in water quality. A decrease in water temperature will have the opposite effect. Please contact Oceanflo desalination if you wish to use the Watermaker in temperatures below 10 degrees Celsius.

Effects of seawater salinity: With an increase in sea water salinity will result in higher operating pressures and more current draw. In areas with decreased salinity, such as areas close to rivers, will result in lower pressures and lower current draw.

Sea water intake: The unit should not be used where the seawater intake can take in a large amount of air. Example, when heeled while sailing. This will result in poor water quality and possible damage to the pump. Always ensure that the water maker has an uninterrupted supply.



Storage chemicals: Under no circumstances should **sodium metabisulphite** be used in the pump. This may lead to irreversible damage to the pump internals. Always use food grade Propylene Glycol (PPG) at 33% or greater concentration.

WARRANTY

Oceanflo Desalination warrants for a period of one year from the date of shipment.

Oceanflo Desalination liability under this warranty shall be limited to repair or replacement of the Oceanflow Watermaker at Oceanflo Desalination option. Under no circumstances shall Oceanflo Desalination be liable for consequential damages arising out of or in any way connected with the failure of the system to perform as set forth herein. This limited warranty is in lieu of all other expressed or implied warranties, including those of merchantability and fitness for a particular purpose.

In event of a defect malfunction or failure during the warranty. Oceanflo Desalination will repair, replace, in it's option the product or component therein which upon examination by Oceanflo Desalination shall appear to be defective, or not up to factory specifications.

To obtain warranty service, the defective product or part must be returned to Oceanflo Desalination service center. The purchaser must pay any transportation or labor expenses incurred in removing and returning the product. A return authorization must be obtained before any part or component is shipped.

The limited warranty does not extend to any system component that has been subject to misuse, neglect, accident, and proper installation, or used in violation of instructions by Oceanflo Desalination. That warranty does not extend to components on which the serial number is being removed, defaced or changed.

Oceanflo Desalination reserves the right to make changes or improvements to its product during subsequent production without incurring the obligation to install such changes or improvements on previously manufactured equipment.

The implied warranties, which the law imposes on the sale of this product, are expressly limited in duration to the time above. Oceanflo Desalination shall not be liable for damages, consequential or otherwise, resulting from the use and operation of this product or from the breach of its limited warranty.

This limited warranty service does not apply to normal reoccurring user maintenance as described below.

Filters
 Pump valve assemblies
 Pre-filter cartridges
 Gauge/instrument calibration

Pump crankcase oil
 Pump seals and packings
 Pump bushings/bearings