



1111 Davis Dr., Unit 23 Newmarket, Ont L3Y 9E5

Tel: 905 716-5856

Email: info@martechsales.com

URL: www.martechsales.com

FA76

Pneumatic Magnetic Gripper



Technical Specifications and Features

Max Hold Force (kgf)	256
Air Port Thread Size	G1/8
Net Weight (kg)	2.1
Max Air Pressure (MPa)	0.7
Normal Actuation Pressure (MPa)	0.5
ON/OFF Position Sensor	Fluxus Sensor, M8 4-Pin Male Connector N.O. (Wiring Diagram on Page 3)
ON/OFF Position Sensor Power Supply	150 mA MAX @ 10-30 VDC
ON/OFF Position Sensor Wire Length (m)	2.4
Maximum Operating Temperature (C)	70
Actuation Time (s)	0.5
Fastest Complete Cycle Frequency (Hz)	0.5

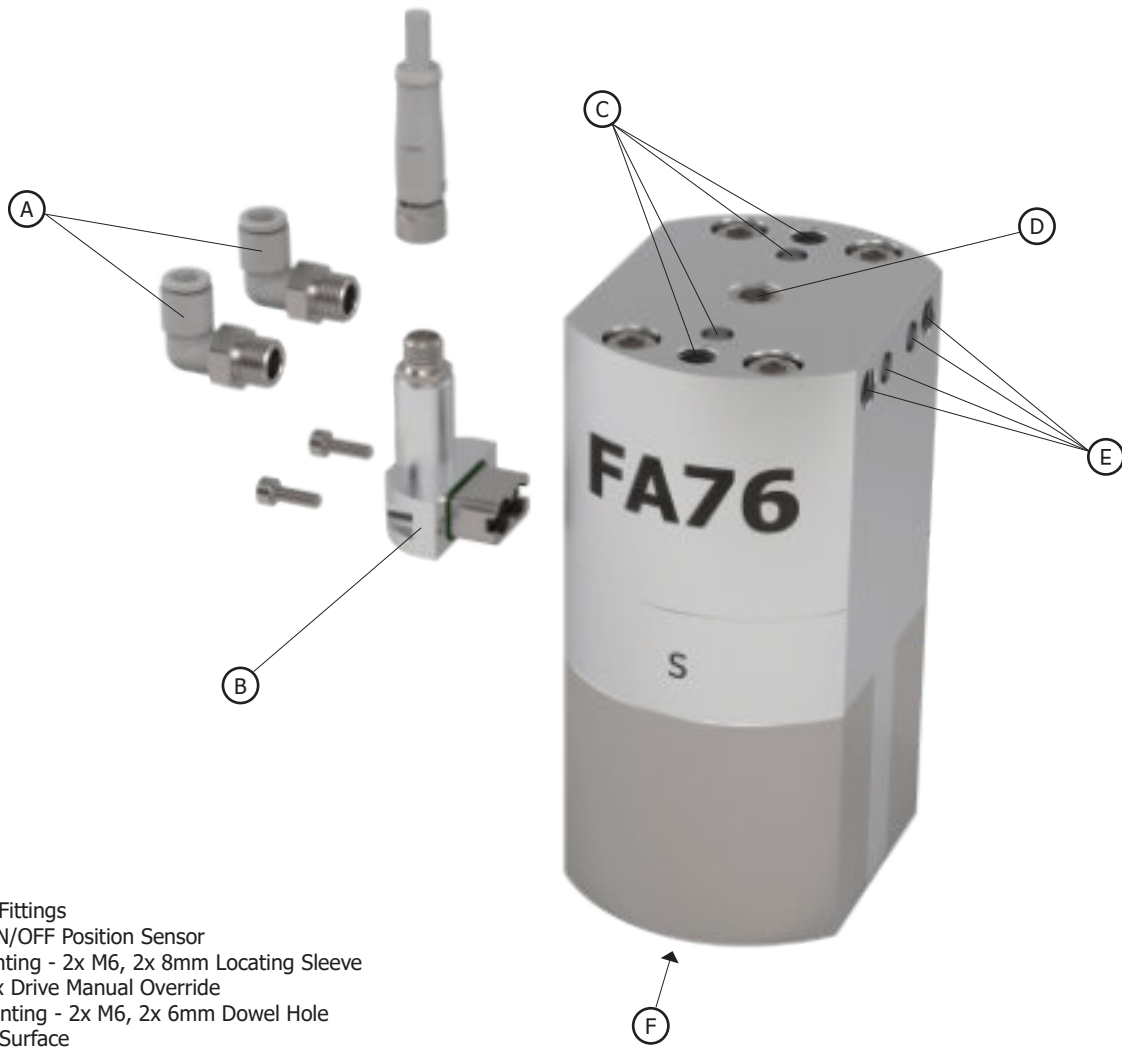

- A. G1/8 Air Fittings
- B. Fluxus ON/OFF Position Sensor
- C. Top Mounting - 2x M6, 2x 8mm Locating Sleeve
- D. 4mm Hex Drive Manual Override
- E. Side Mounting - 2x M6, 2x 6mm Dowel Hole
- F. Gripping Surface

DISCLAIMERS AND WARRANTY

This product should be operated using clean, dry air and within the specified operating parameters. It should only be actuated when in direct contact with a steel target. When adhering to these guidelines, the product is covered under warranty for a period of one (1) year or up to one and a half (1.5) million cycles, whichever occurs first.

Performance

Flux Force and Recommended Safe Working Loads

Target Thickness (mm)	0.4	0.5	0.6	0.8	1.0	1.2	1.5	2.0	2.5	3	3.5	4	4.5	5	5.5	7	8	>10
Flux Force (kgf)	8.3	11.3	14.4	22.0	27.4	34.5	41.8	67.1	94.5	116.6	134.5	155.0	190.9	217.3	233.8	242.1	256.0	256.0
Normal Work Load (kg)	1.7	2.3	2.9	4.4	5.5	6.9	8.4	13.4	18.9	23.3	26.6	31.0	38.2	43.5	46.8	48.4	51.2	51.2
Shear Work Load (kg)	0.8	1.1	1.4	2.2	2.7	3.4	4.2	6.7	9.5	11.7	13.4	15.5	19.1	21.7	23.4	24.2	25.6	25.6

- Flux Force is the amount of gripping force generated by the product on a target part.
- Normal Work Load is the max target part weight recommended for handling in the normal or horizontal orientation.
- Shear Work Load is the max target part weight recommended for handling in shear or vertical orientation
- Derating factors can be used to make calculations to estimate the final Flux Force in an application.

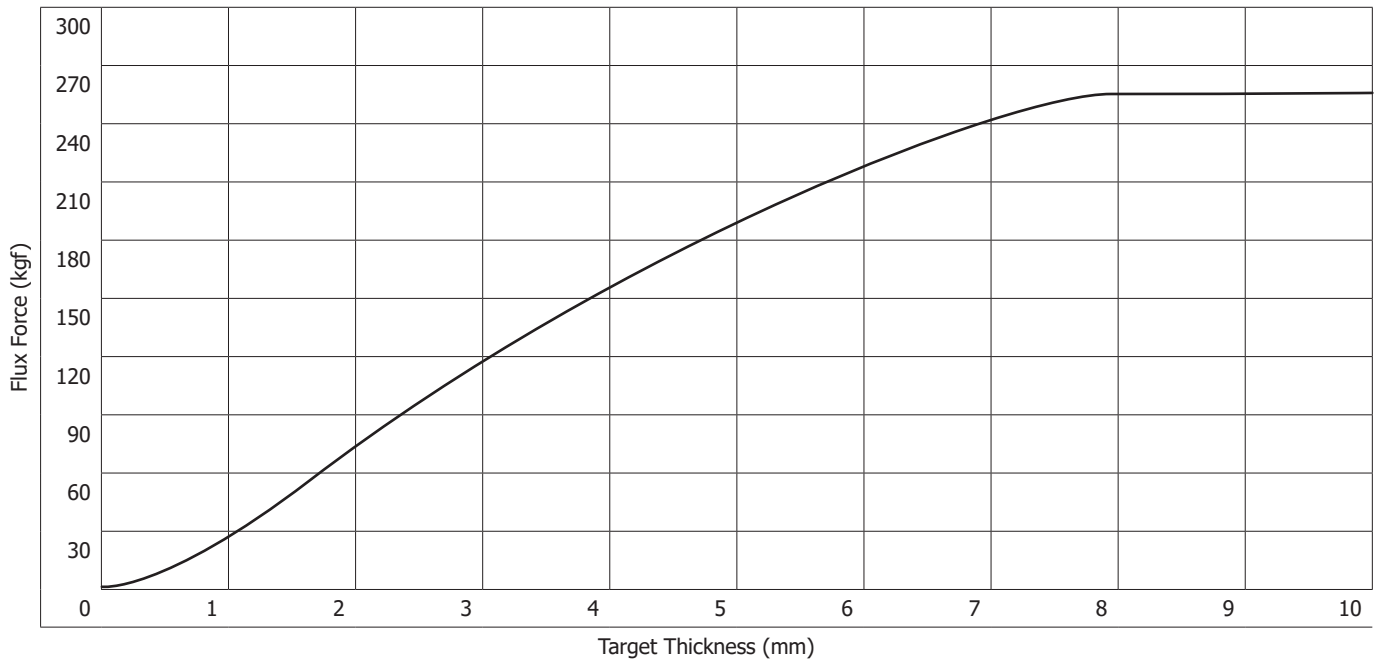

Flux Force Deratings for Material and Contact Condition

Condition	Derating Factor
Target Material - Low Carbon Steel	1.0
Target Material - High Carbon Steel	0.9
Target Material - Ferritic Stainless Steel	0.5
Target Material - Cast Iron	0.45
Contact - Perfect Flat	1.0
Contact - Imperfect Flat / Rough Surface	0.9
Contact - V Pole on Round	0.5
Contact - Multi-Point	0.5
Orientation - Normal	1.0
Orientation - Shear	0.5

Calculation Examples

Example A - FA46 with V poles handling a 2mm thick mild steel tube that weighs 3kg in normal orientation only.

(FA46 Flux Force on 2mm) x (V Pole on Round) x (Low Carbon Steel) = Estimated Flux Force

$$47.5 \times 0.5 \times 1.0 = 23.75\text{kgf Flux Force}$$

Example B - FA76 with flat poles handling a 10mm thick rough surface cast iron part that weighs 10kg in shear orientation.

(FA76 Flux Force on 10mm) x (Rough Surface) x (Cast Iron) x (Shear) = Estimated Flux Force

$$256.0 \times 0.9 \times 0.45 \times 0.5 = 51.8\text{kgf Flux Force}$$

Dimensions

FA76 Base Dimensions with No Poles and No Sensors

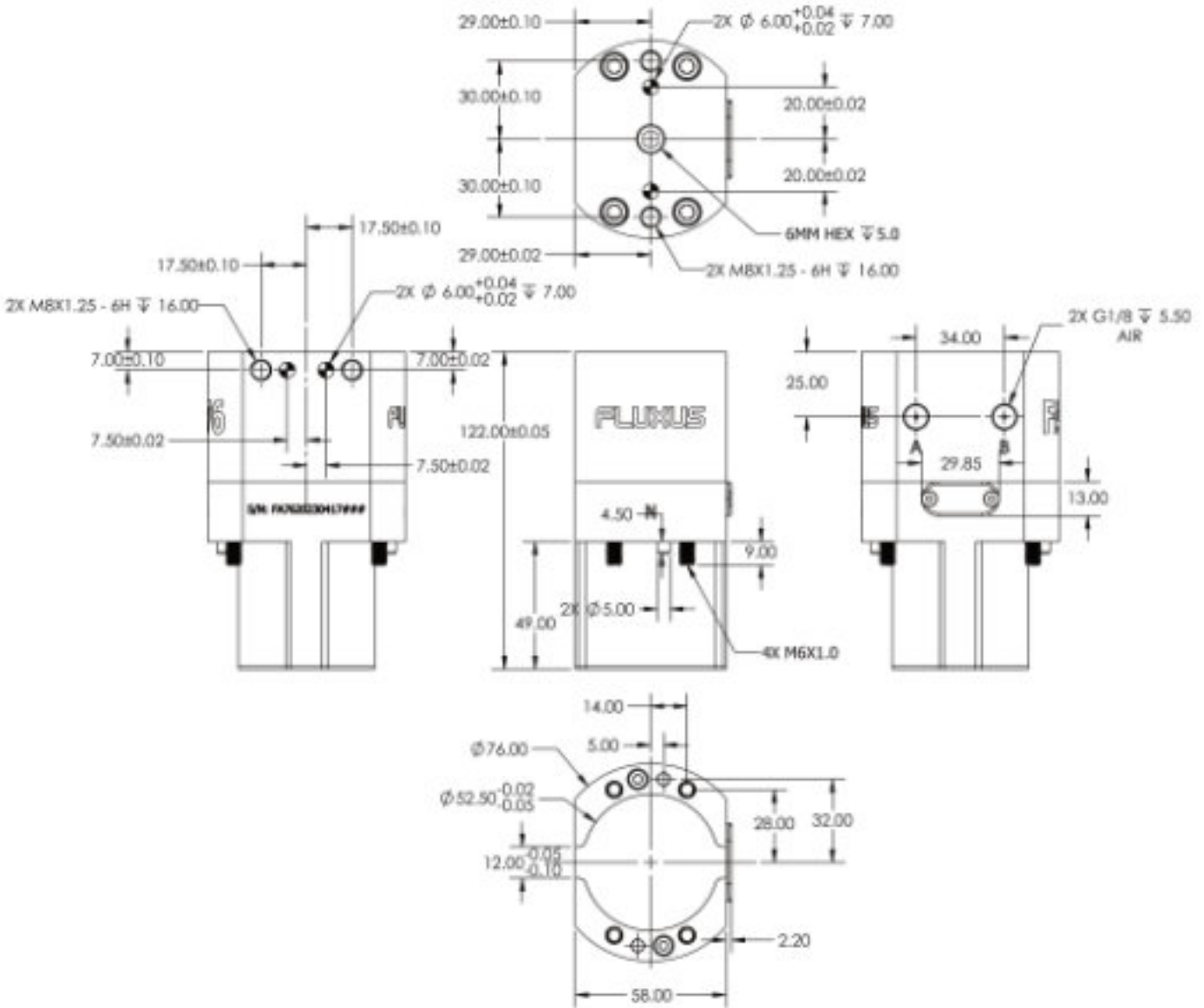

FA76 Standard Sensor Dimensions & Wiring Diagram

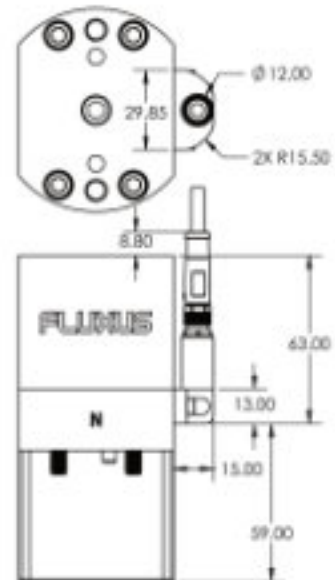
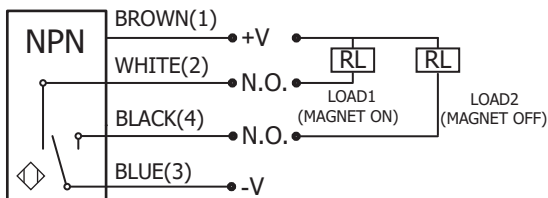
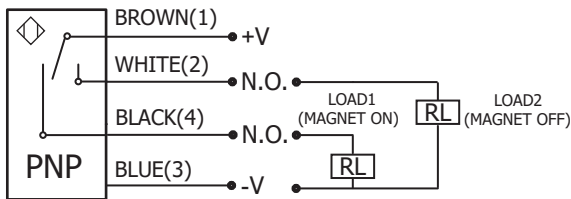

Dimensions

FA76 Standard Flat Pole

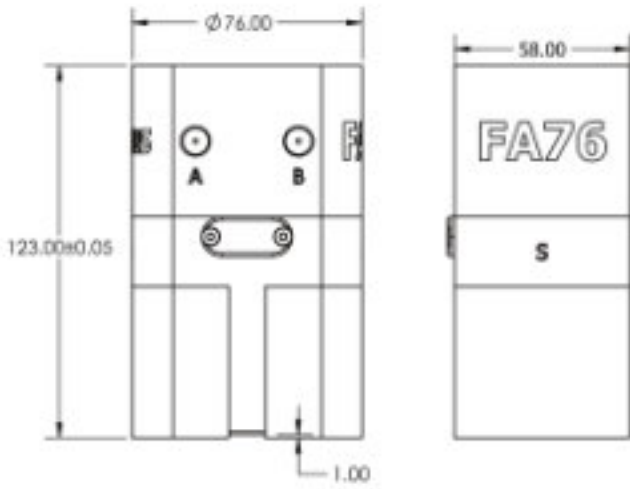

FA76 Standard V Pole

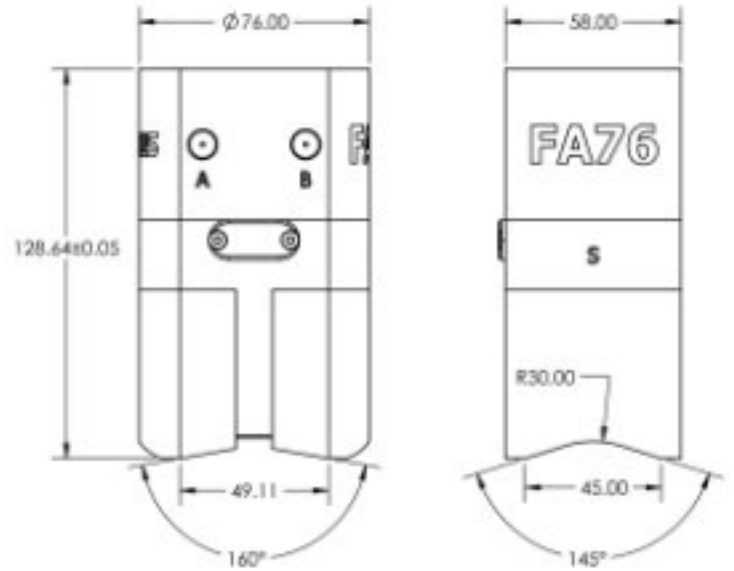

*Optimized for round targets
120mm - 240mm OD*

*Optimized for round targets
30mm - 120mm OD*

FA76 Standard Pin Pole

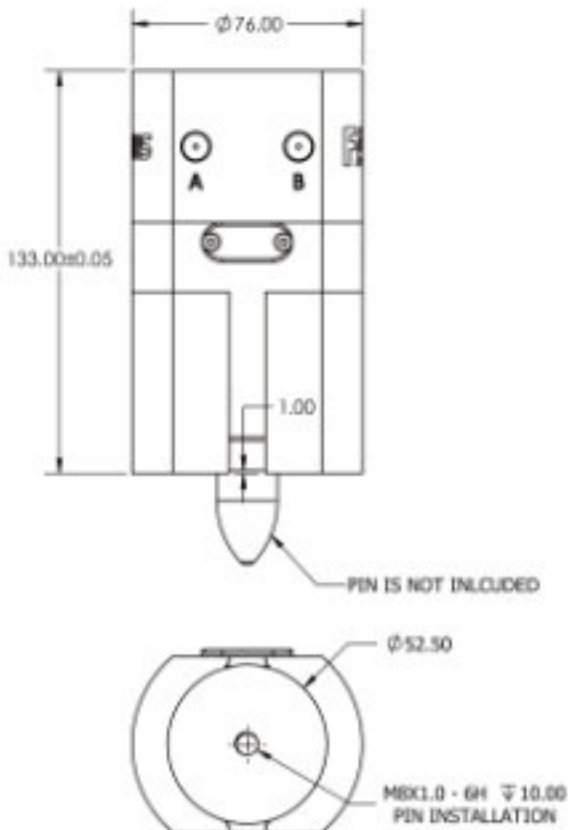

FA76 Standard Blank Pole

