



1111 Davis Dr., Unit 23, Newmarket, Ont L3Y 9E5
Tel: 905 716-5856
Email: info@martechsales.com
URL: www.martechsales.com

FA28

Pneumatic Magnetic Gripper



Technical Specifications and Features

Max Hold Force (kgf)	16.5
Air Port Thread Size	M5
Net Weight (kg)	0.2
Max Air Pressure (MPa)	0.7
Normal Actuation Pressure (MPa)	0.2
ON/OFF Position Sensor	4mm C-Slot Magnetic Sensor, 3-Wire Pigtail, N.O. (Wiring Diagram on Page 3)
ON/OFF Position Sensor Power Supply	40 mA MAX @ 4.8-28 VDC
ON/OFF Position Sensor Wire Length (m)	3
Maximum Operating Temperature (C)	60
Actuation Time (s)	0.1
Fastest Complete Cycle Frequency (Hz)	2

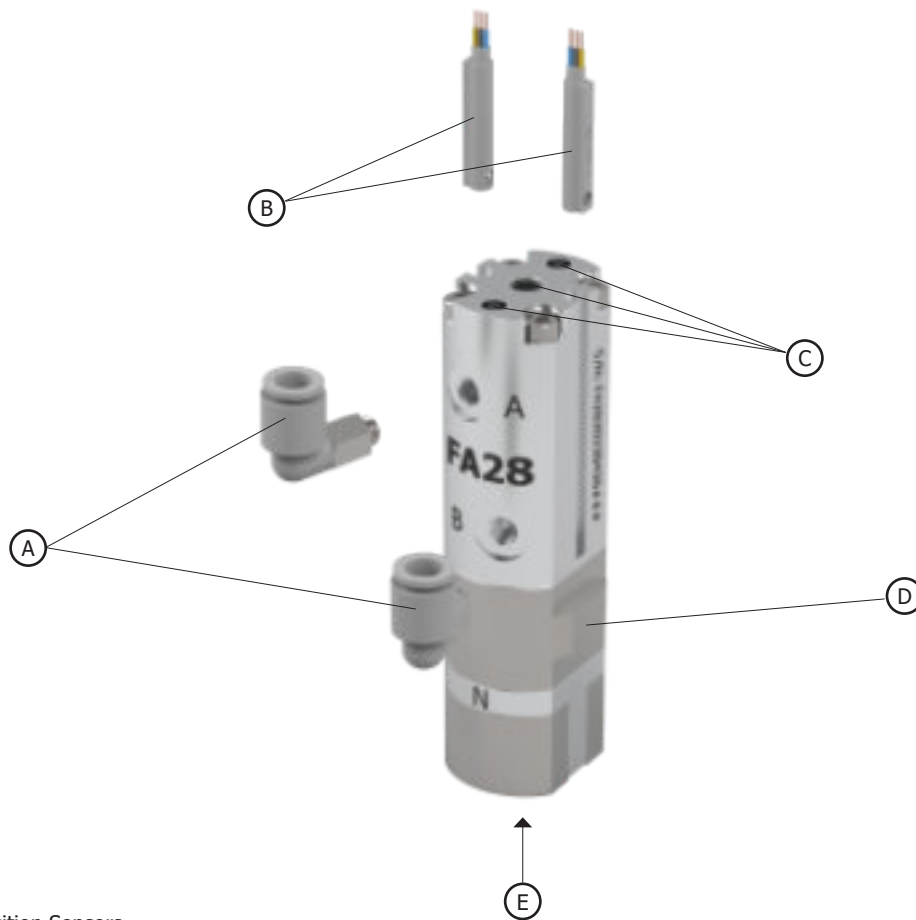

- A. M5 Air Fittings
- B. 4mm C-Slot Position Sensors
- C. Top Mounting - 1x M6, 2x 8mm Locating Sleeve
- D. Side Mounting - 2x M6, 2x 6mm Dowel Hole
- E. Gripping Surface

DISCLAIMERS AND WARRANTY

This product should be operated using clean, dry air and within the specified operating parameters. It should only be actuated when in direct contact with a steel target. When adhering to these guidelines, the product is covered under warranty for a period of one (1) year or up to one and a half (1.5) million cycles, whichever occurs first.

Performance

Flux Force and Recommended Safe Working Loads

Target Thickness (mm)	0.4	0.5	0.6	0.8	1.0	1.2	1.5	2.0	2.5	>3
Flux Force (kgf)	2.3	3.6	4.0	7.7	8.8	11	13.6	15.5	16.5	16.5
Normal Work Load (kg)	0.46	0.72	0.8	1.54	1.76	2.2	2.72	3.1	3.3	3.3
Shear Work Load (kg)	0.23	0.36	0.4	0.77	0.88	1.1	1.36	1.55	1.65	1.65

- Flux Force is the amount of gripping force generated by the product on a target part.
- Normal Work Load is the max target part weight recommended for handling in the normal or horizontal orientation.
- Shear Work Load is the max target part weight recommended for handling in shear or vertical orientation
- Derating factors can be used to make calculations to estimate the final Flux Force in an application.

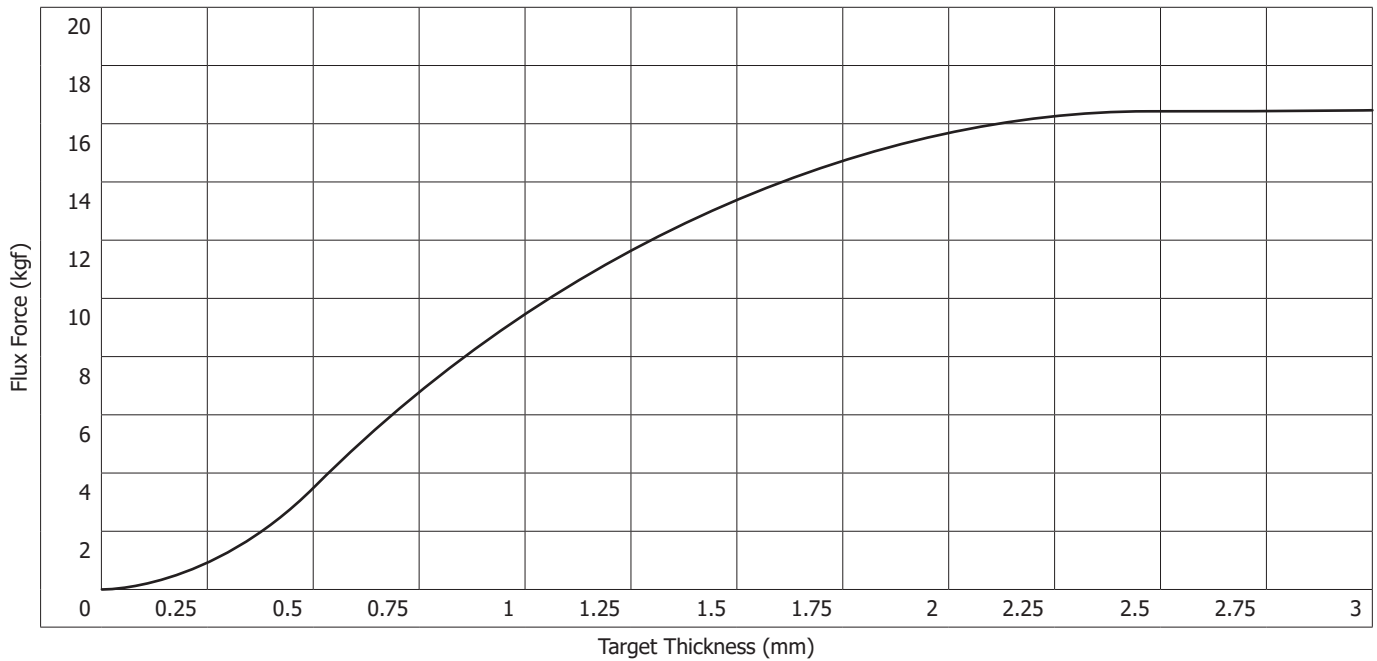

Flux Force Deratings for Material and Contact Condition

Condition	Derating Factor
Target Material - Low Carbon Steel	1.0
Target Material - High Carbon Steel	0.9
Target Material - Ferritic Stainless Steel	0.5
Target Material - Cast Iron	0.45
Contact - Perfect Flat	1.0
Contact - Imperfect Flat / Rough Surface	0.9
Contact - V Pole on Round	0.5
Contact - Multi-Point	0.5
Orientation - Normal	1.0
Orientation - Shear	0.5

Calculation Examples

Example A - FA46 with V poles handling a 2mm thick mild steel tube that weighs 3kg in normal orientation only.

(FA46 Flux Force on 2mm) x (V Pole on Round) x (Low Carbon Steel) = Estimated Flux Force

$$47.5 \times 0.5 \times 1.0 = 23.75\text{kgf Flux Force}$$

Example B - FA76 with flat poles handling a 10mm thick rough surface cast iron part that weighs 10kg in shear orientation.

(FA76 Flux Force on 10mm) x (Rough Surface) x (Cast Iron) x (Shear) = Estimated Flux Force

$$256.0 \times 0.9 \times 0.45 \times 0.5 = 51.8\text{kgf Flux Force}$$

Dimensions

FA28 Base Dimensions with No Poles and No Sensors

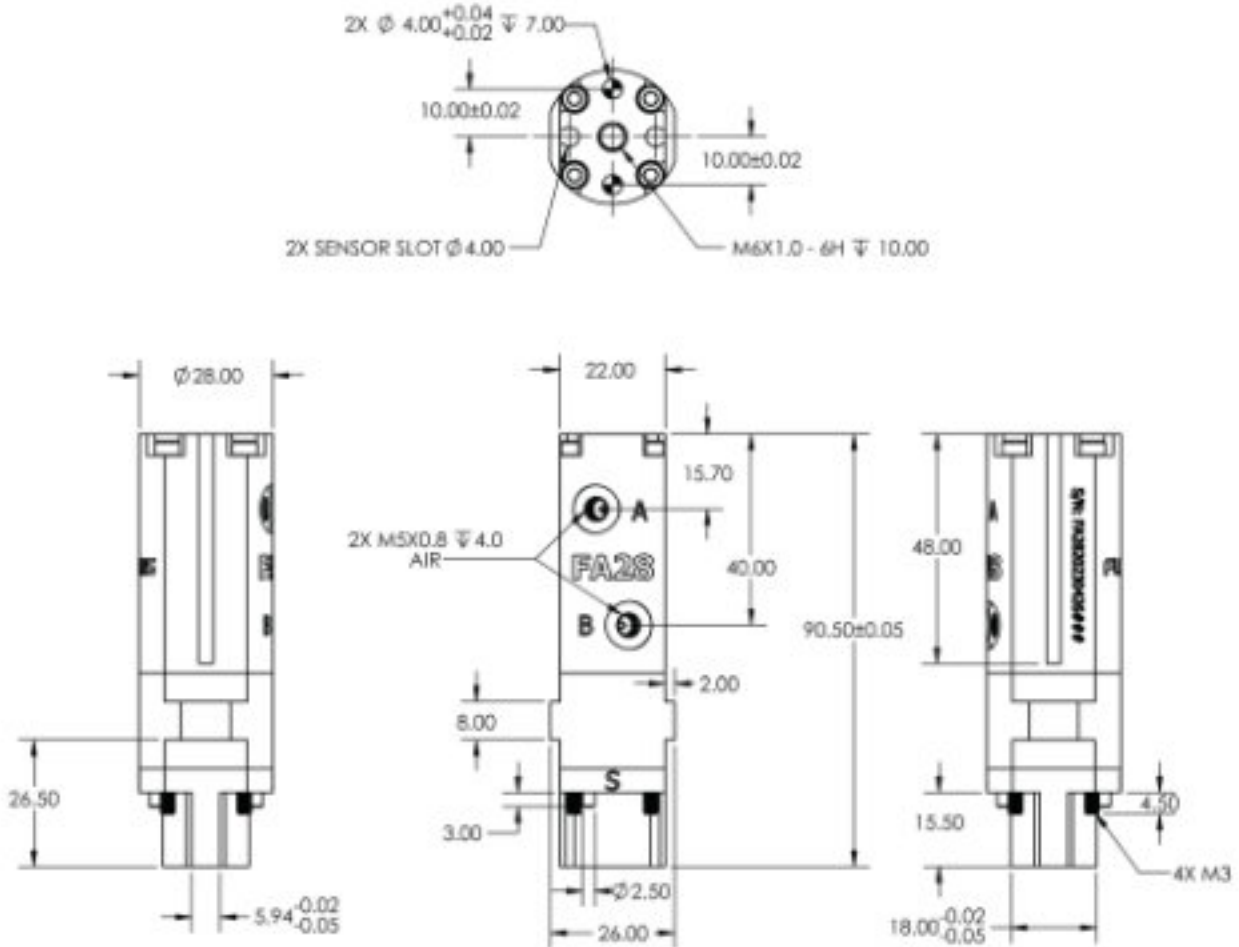

FA28 Standard Sensor Dimensions & Wiring Diagram

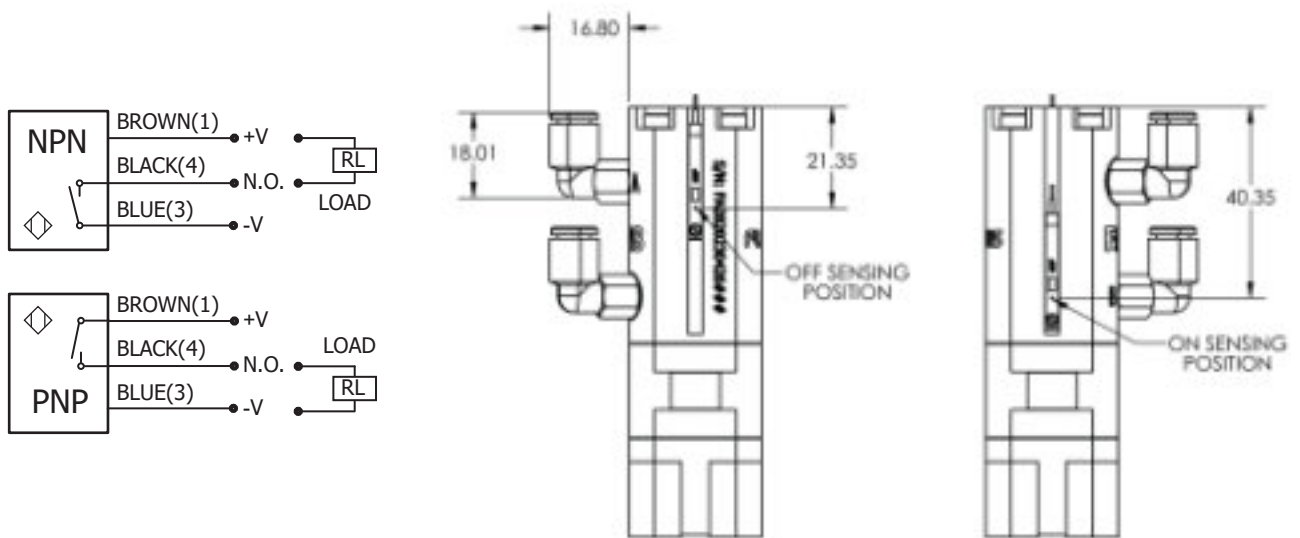

Upper sensor is for sensing magnet OFF. Lower sensor is for sensing magnet ON. Various sensor models could have slightly different mounting locations.

Dimensions

FA28 Standard Flat Pole

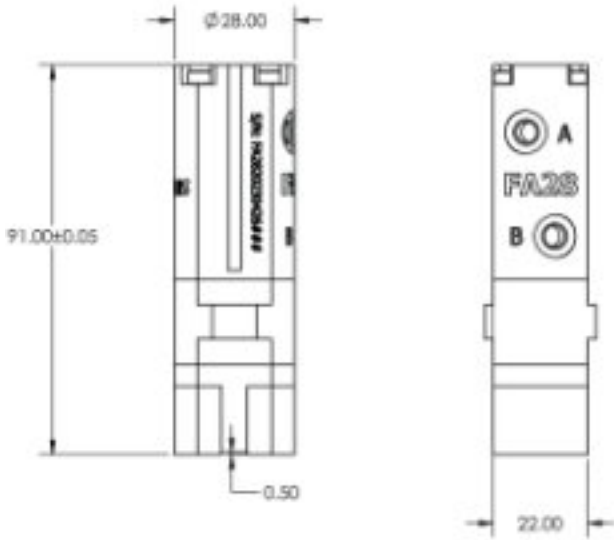

FA28 Standard V Pole

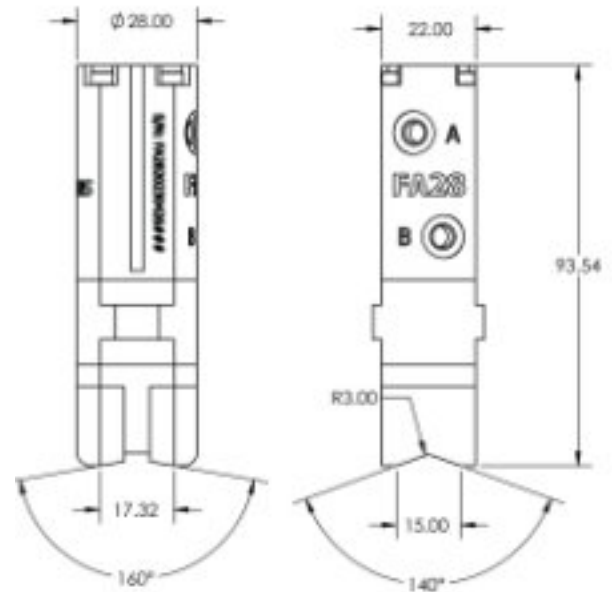

*Optimized for round targets
35mm - 70mm OD*

*Optimized for round targets
6m - 35mm OD*

FA28 Standard Pin Pole

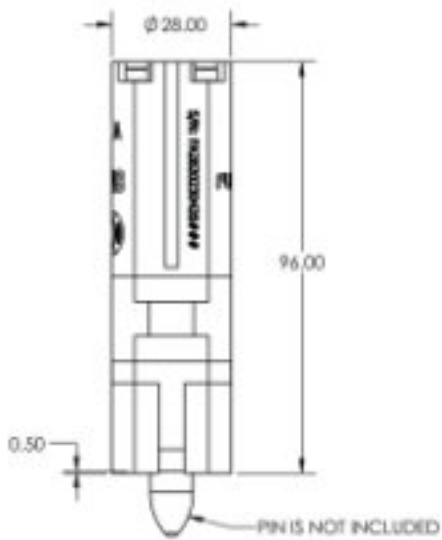

FA28 Standard Blank Pole

