

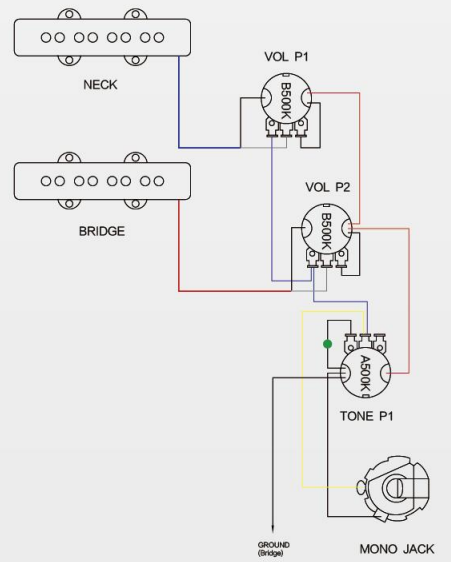

PB STYLE
ASSEMBLY DIAGRAM

JB-JB,2V/1T



YOU NEED A SCREWDRIVER



YOU NEED A WRENCH



**YOU NEED TO USE
WIRE CUTTERS**



**PAY ATTENTION TO
ASSEMBLING**

1



11



10



9



6



2

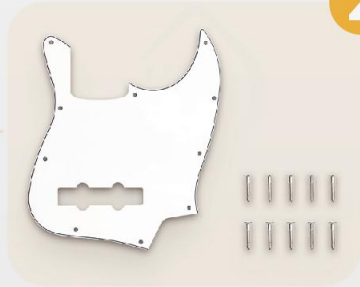

3

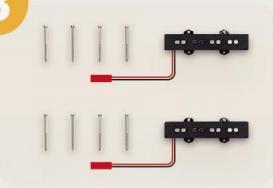

4

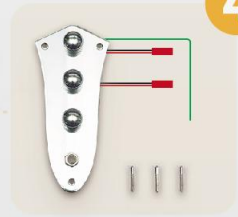

5



8



LIST OF ALL PARTS
SUGGESTED ASSEMBLY SEQUENCE



B

A



C

D

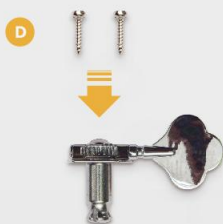
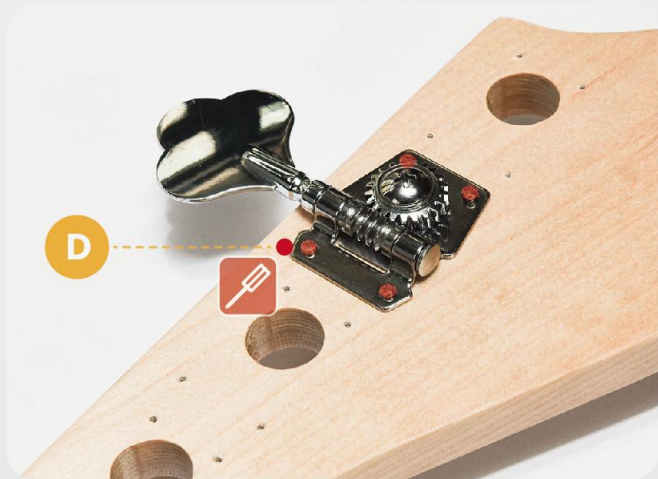



A



B

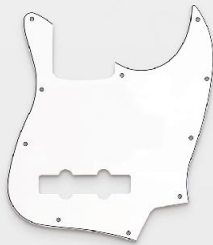

C

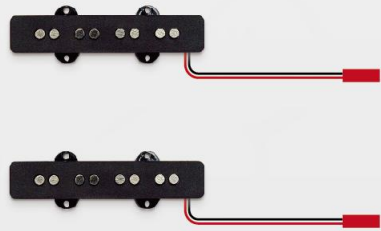

D

E

B



A



C



Wiring diagram

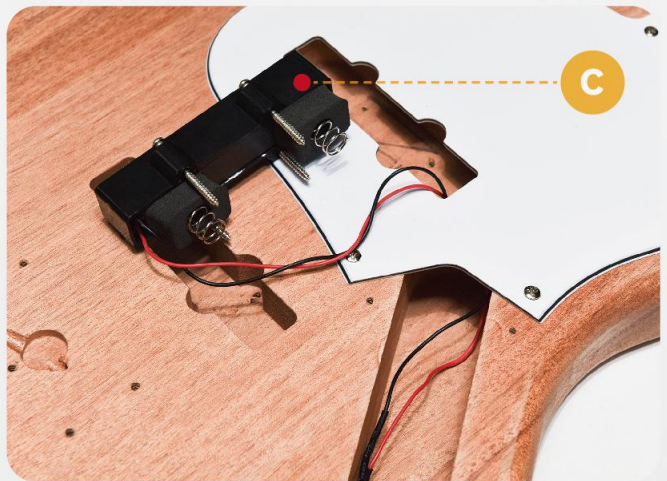

E





Wiring diagram

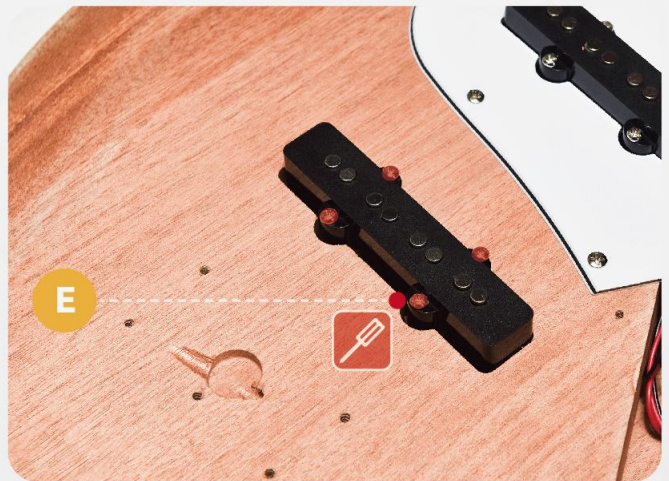
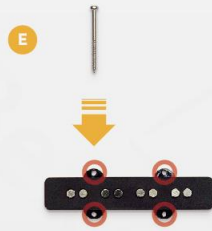
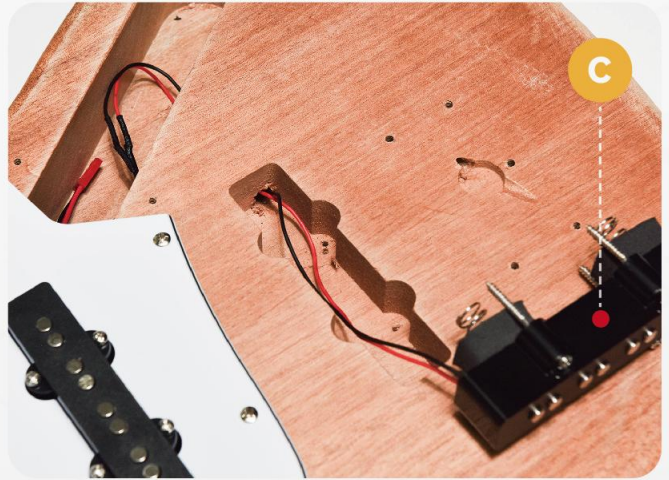



A

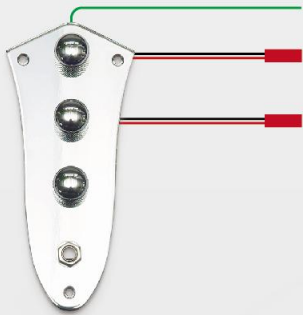

B



C



D



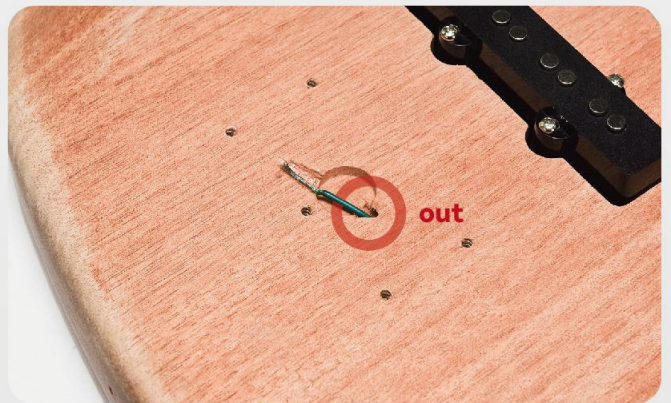
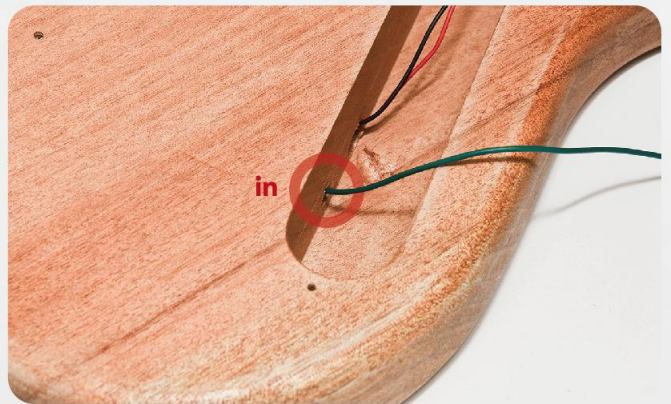
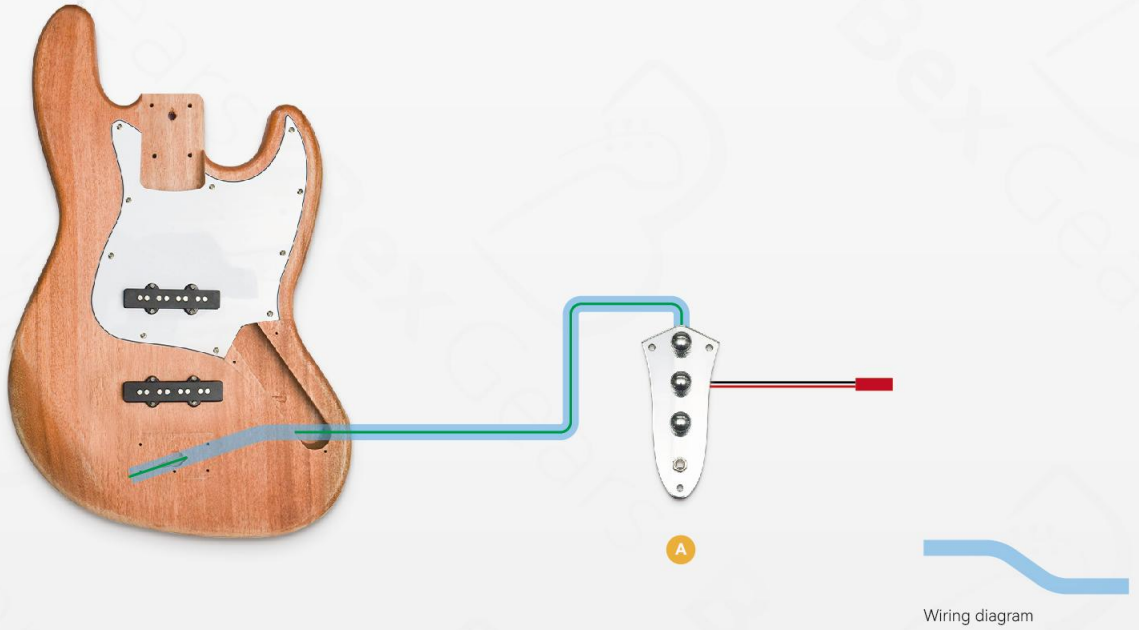

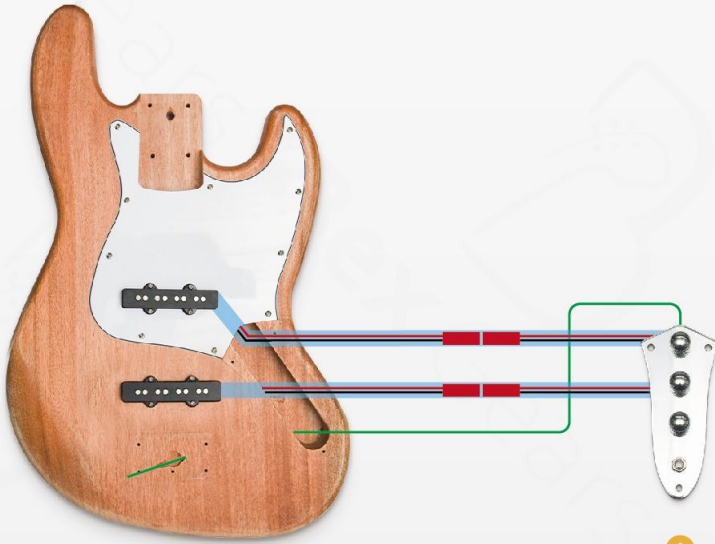

A



Wiring diagram



B

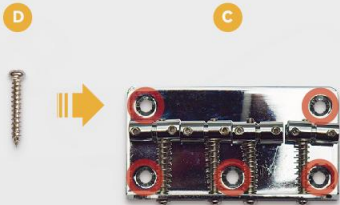

D



A



B



C



D



E



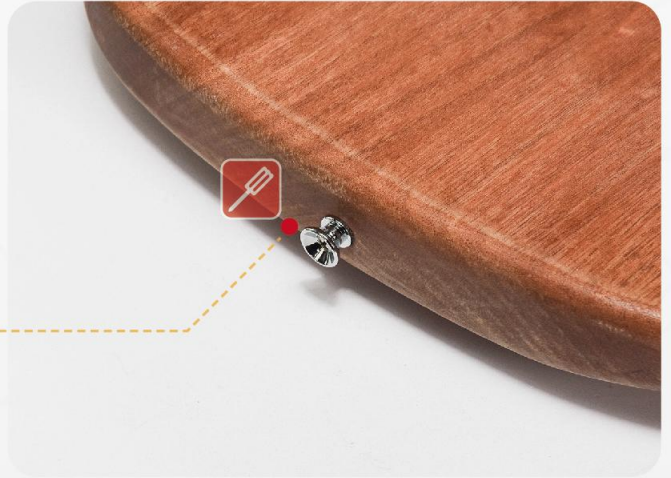



A



B



C



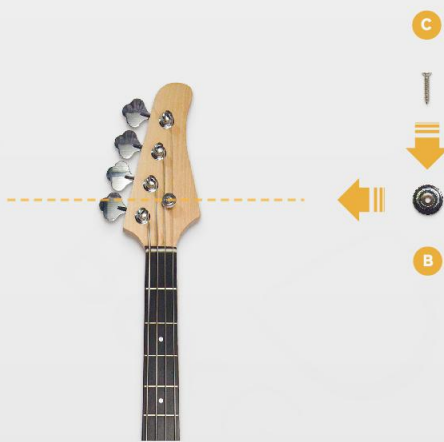
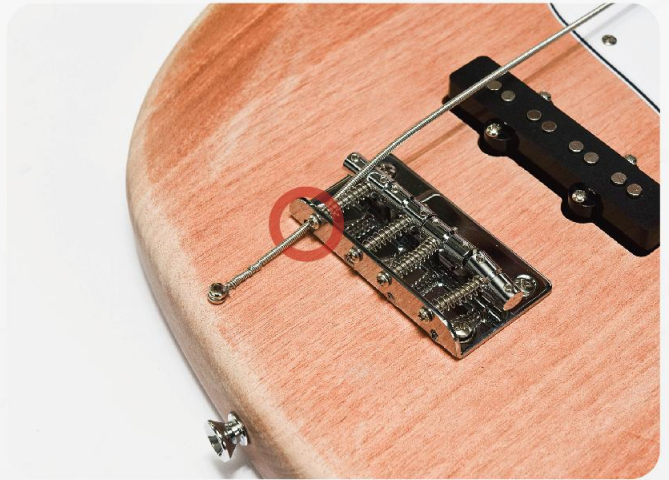

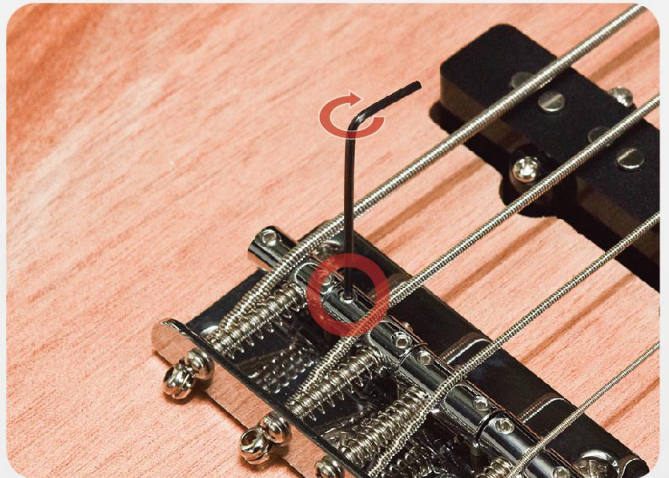



ENJOY



Bex Gears