

EC4-ZR3

Multi-input signal panel meter and control with universal power supply

Multisignal digital panel meter with 4 relays and analog output. Configurable to read AC and DC voltages (up to 600 V), AC and DC amperes (up to 5 A), process signals (mA and Vdc) with and without excitation voltage, thermocouples K, J, E, N, L, R, S, B, T and C, temperature probes Pt100 with 2 and 3 wires, Pt500, Pt1000, Ni100, Ni200, Ni1000, PTC and NTC, resistances, potentiometers and frequency. AC measures in True RMS. Standard 96 x 48 mm (1/8 DIN) size. Scalable reading with 4 digits (9999 to -1999) and configurable decimal point. 'Fast access' function to alarm setpoints, external contact for special functions, 'Eco' mode for reduced consumption, 5 brightness levels. Single universal power supply 18 to 265 Vac/dc. Includes 4 relays SPST and 1 analog output 4/20mA isolated.

Technical specifications

Digits	4
Reading	9999 / -1999
Decimal point	configurable
Led color	red
Digit height	14 mm
Accepted signal ranges	<i>see tables at page 3 for more information</i>
• AC voltages and AC currents	~600 Vac, ~200 Vac, ~20 Vac, ~2 Vac ~200 mVac, ~60 mVac, ~5 Aac, ~20 mAac (True RMS measure) (accepts phase-neutral and phase-phase measure) (frequency up to 150 Hz)
• DC voltages and DC currents	±600 Vdc, ±200 Vdc, ±20 Vdc, ±2 Vdc ±200 mVdc, ±60 mVdc, ±5 Adc, ±20 mAac
• thermocouples	K, J, E, N, L, R, S, B, T and C (automatic cold junction compensation)
• resistive 'Pt' probes	Pt100 with 2 and 3 wires, Pt500, Pt1000
• resistive 'Ni' probes	Ni100, Ni200, Ni1000
• resistive NTC probes	<i>see table at page 3</i>
• resistive PTC probes	families KTY-121, KTY-210 and KTY-220
• process	4/20 mA, 0/10 Vdc (+15 Vdc @30 mA exc. voltage. Configurable at terminal 5)
• frequency	up to 100 Hz (minimum 15 Hz). Vac and Aac ranges.
• resistances	ranges 0/5 K and 0/50 K
• potentiometers	with nominal values from 500 R up to 20 K
Thermal drift offset+span	150 ppm/°C
Readings	3 readings / second
Refresh	3 refresh / second
Response time	<300 mSec. (0 % to 99 % of signal)
Universal Power Supply	18 to 265 Vac/dc (isolated 1500 Veff @60 seconds)

How to order

Series	Model	Customization
EC4	ZR3	XXXX
<p>↑</p> <p>-XXXX (customized execution) -(empty)</p>		



Dimensions (mm)

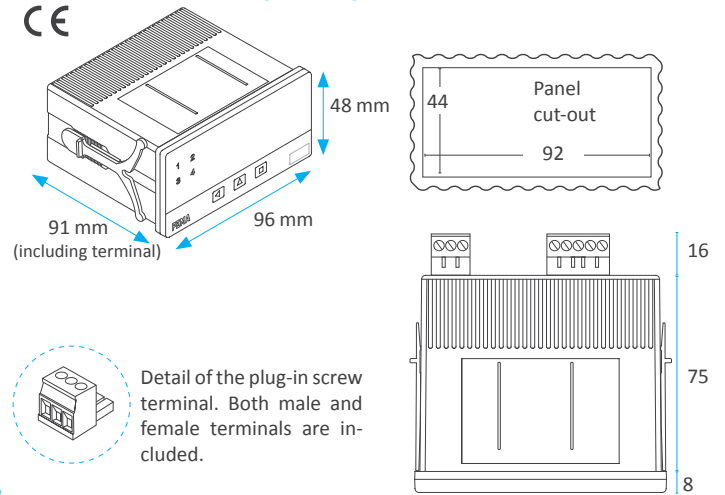

Relay outputs	4 relays isolated (2500Veff) SPST, 2 terminals, pitch 5.08 mm up to 250 Vac @6 Amperes
Analog output	4/20 mA isolated (1000Vdc) analog output active output (change internal jumper for 'passive')
Protection	IP65 front protection
Consumption (normal mode)	<4.0 W
Connections	plug-in screw terminals
Weight	<200 grams
Package box	paperboard 15x12x5 cm
Temperature of operation	0 to 55 °C



Additional documentation

User's manual EC4-ZR3 www.fema.es/docs/4608_EC4-ZR3_manual_en.pdf
 Datasheet EC4-ZR3 www.fema.es/docs/4609_EC4-ZR3_datasheet_en.pdf
 Quick installation guide EC4-ZR3 www.fema.es/docs/4610_EC4-ZR3_installation_en.pdf

Functions included

- 'Fast access' menu press the 'UP' ('▲') front key to access and modify the alarm setpoints, and / or the maximum and minimum memory. Configurable menu
- 'External control' function. external contact at multifunctional terminal 5, configurable for : 'hold' the reading, activate the maximum or minimum memory
- 'Eco' mode. automatic turn off of the display leds, to reduce the consumption of the instrument when the operator is not using it
- Alarms 4 alarms, independent, configurable as maximum or minimum, with setpoint and hysteresis
- Fail safe mode. An upper and lower limit can be configured to disable all alarms
- Reading offset. this function allows to configure a fixed number of counts to be added to the reading
- Display filters. recursive filter for noisy signals and configurable steps for minimum predefined changes on the reading
- 20 segment linearization linearization of process signals up to 20 points
- Brightness configurable 5 levels of brightness intensity
- Password blocks the configuration menu
- Memory memory of maximum and minimum
- Front labeling set of measure units labeling 'Units7' included

Connections and rear view

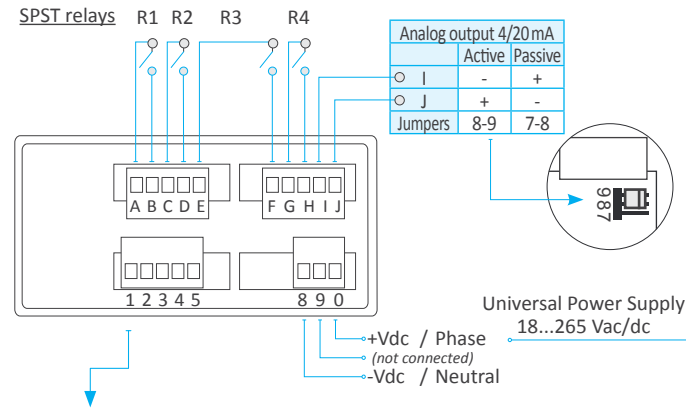

1	2	3	4	5	Ranges
~Vac +Vdc			~Vac -Vdc		~600 Vac, ±600 Vdc, ~200 Vac, ±200 Vdc
	~Vac +Vdc		~Vac -Vdc		~20V, ~2V, ~200 mV, ~60 mV, ~20 mA ±20V, ±2V, ±200 mV, ±60 mV, ±20 mA
		~Aac +Adc	~Aac -Adc		~5 Aac ±5 Adc
	tc+		tc-		Thermocouple
	+		-		Pt (2 wires), Ni, NTC, PTC
	pt+		pt-	Sense	Pt100 (3 wires)
	mA			Vexc.	4/20 mA passive
	mA+		mA-		4/20 mA active
	+Vdc		common	Vexc.	0/10 Vdc passive
	+Vdc		common		0/10 Vdc active
	res+		res-		Resistance
	signal		pot-	pot+	Potentiometer

⚡ Risk of electric shock. The 'EK' external control function shares terminal 4 with the common of the input signal connection. When measuring dangerous voltages AND using 'EK' external control contact, apply the appropriate protections to isolate the operator from dangerous voltages.

As requested by security regulations EN-61010-1, add a protection fuse to the power line, with value :
 250 mA time-lag for power voltage > 50 Vac/dc
 400 mA time-lag for power voltage < 50 Vac/dc

Internal structure and jumpers for range selection

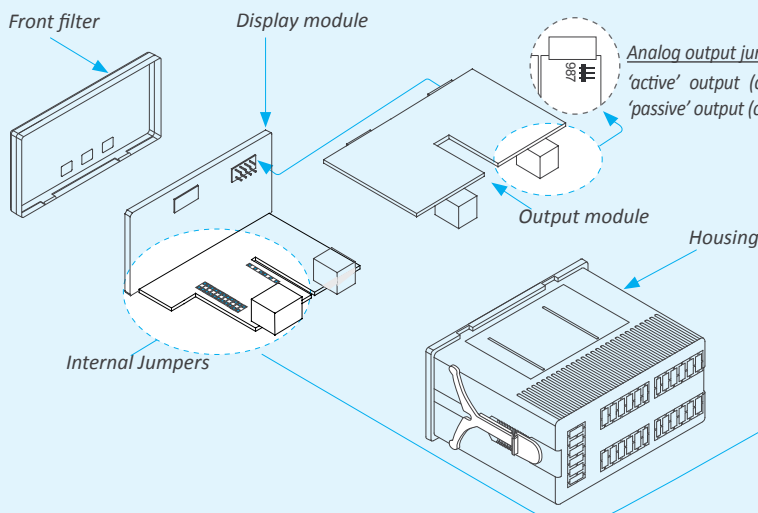

Example #1
 Jumpers 'S' placed for the range of ±600Vdc, jumpers G & I.
 Jumper 'T' between 4-5 for EK external control function.
 Jumper not used placed between A-B of non-use.

Example #2
 Jumpers 'S' placed for the range of 4/20mA, jumper D.
 Jumper 'T' between 1-2 for +15Vdc excitation voltage.
 Jumpers not used placed between A-B and E-F of non-use.

Input signal ranges - Technical specifications

Vac ranges (Veff.)	Scale by default	Scalable	Jumpers 'S'	Jumper 'T'	Accuracy (% FS)	Max. oversignal	Z _{in}
~600 Vac*	600	from 9999 to -1999	G & I	4-5	<0.30% (up to 150Hz)	800 Vac	12 MOhm
~200 Vac	200.0		I			800 Vac	12 MOhm
~20 Vac	20.00		A & I			150 Vac	1 MOhm
~2 Vac	2.000		B & I			100 Vac	100 KOhm
~200 mVac	200.0		C & I			30 Vac	10 KOhm
~60 mVac	60.0		E & I			3 Vac	1 MOhm

* measure 300V CAT-III , 600V CAT-II. Measure of frequency available for all ranges.

Vdc ranges	Scale by default	Scalable	Jumpers 'S'	Jumper 'T'	Accuracy (% FS)	Max. oversignal	Z _{in}
±600 Vdc	600	from 9999 to -1999	G	4-5	<0.20%	800 Vdc	12 MOhm
±200 Vdc	200.0		---			800 Vdc	12 MOhm
±20 Vdc	20.00		A			150 Vdc	1 MOhm
±2 Vdc	2.000		B			100 Vdc	100 KOhm
±200 mVdc	200.0		C			30 Vdc	10 KOhm
±60 mVdc	60.0		E			3 Vdc	1 MOhm

Aac ranges (Aeff.)	Scale by default	Scalable	Jumpers 'S'	Jumper 'T'	Accuracy (% FS)	Max. oversignal	Z _{in}
~5 Aac	5.00	from 9999 to -1999	I	4-5	<0.50% (up to 150Hz)	7 Aac (max. 7 sec.)	20 mOhm
~20 mAac	20.00		D & I			25 mAac	4.7 Ohm

Adc ranges	Scale by default	Scalable	Jumpers 'S'	Jumper 'T'	Accuracy (% FS)	Max. oversignal	Z _{in}
±5 Adc	±5.00	from 9999 to -1999	---	4-5	<0.25%	7 Adc (max. 7 sec.)	20 mOhm
±20 mAac	±20.00		D			25 mAac	4.7 Ohm

Process signals	Scale by default	Scalable	Jumpers 'S'	Jumper 'T'	Accuracy (% FS)	Max. oversignal	Z _{in}
4/20 mA	0/100.0	from 9999 to -1999	D	1-2'	<0.15%	25 mA	4.7 Ohm
0/10 Vdc	0/100.0		A		<0.20%	25 Vdc	1 MOhm

* Place jumper 'T' at position 1-2 for +15 Vdc excitation voltage at terminal 5. Optionally, place jumper 'T' at position 4-5 to work with 'external contact' at terminal 5.

NTC probes 'R ₂₅ '* (configurable)	Jumpers 'S'	Jumper 'T'	Range of measure	Accuracy (% of reading)	Beta* (configurable)
10K	F & K	4-5	-60 °C to 150 °C	<1.5% of reading	3500

*'Beta' configurable (2000 to 5500). R25 configurable. Resistance measure from 100R to 1MR.

PTC probes Family	Jumpers 'S'	Jumper 'T'	Range in °C (in °F)	Total error
KTY-121	F	4-5	-55 / 150 °C (-67 / 302 °F)	<1 °C
KTY-210	F & H & K			
KTY-220	F & H & K			

Thermocouples	Jumpers 'S'	Jumper 'T'	Range in °C (in °F)	Total error (cold junction included)
tc. K	E	4-5	-100 / 1350 °C (-148 / 2462 °F)	<3 °C
tc. J			-100 / 1200 °C (-148 / 2192 °F)	
tc. E			-100 / 1000 °C (-148 / 1832 °F)	
tc. N			-100 / 1300 °C (-148 / 2372 °F)	
tc. L			-100 / 900 °C (-148 / 1652 °F)	
tc. R			0 / 1768 °C (32 / 3214 °F)	
tc. S	E & J	0 / 1768 °C (32 / 3214 °F)	<5 °C	
tc. T	-100 / 400 °C (-148 / 752 °F)			
tc. C	E	0 / 2300 °C (32 / 4172 °F)		
tc. B	E & J	700 / 1820 °C (1292 / 3308 °F)		

Pt and Ni probes	Jumpers 'S'	Jumper 'T'	Range in °C (in °F)	Total error	Current at sensor
Pt100 (3 wires)	F & H & J	5-6	-200 / 700 °C (-328 / 1292 °F)	<1°C	< 900 uA
Pt100 (2 wires)	F & H	4-5	-200 / 700 °C (-328 / 1292 °F)		< 900 uA
Pt500	F		-150 / 630 °C (-238 / 1166 °F)		< 90 uA
Pt1000	F		-190 / 630 °C (-310 / 1166 °F)		< 90 uA
Ni100	F & H		-60 / 180 °C (-76 / 356 °F)		< 900 uA
Ni200	F & H		-60 / 120 °C (-76 / 248 °F)		< 900 uA
Ni1000	F		-60 / 180 °C (-76 / 356 °F)		< 90 uA

Resistance ranges	Scale by default	Scalable	Jumpers 'S'	Jumper 'T'	Accuracy (% of reading)
0 a 5 KOhm	5.000	from 9999 to -1999	F & H & K	4-5	<1.5% of reading
0 a 50 KOhm	50.00		F & K		

Potentiometers nominal value	Scale by default	Scalable	Jumpers 'S'	Jumper 'T'	Accuracy (% FS)
500 Ohm to 20 KOhm	0/100.0	from 9999 to -1999	A	2-3	<0.5%

Frequency signals	Scale by default	Scalable	Jumpers 'S'	Jumper 'T'	Accuracy (% reading)
15 Hz to 100 Hz	0/100.0	from 9999 to -1999	Vac or Aac ranges	4-5	<0.15% of reading

 'Max. oversignal' is the maximum signal accepted by the instrument. Higher signal values may cause instrument damage. Lower values are not destructive but may be out of accuracy specifications.

Options and accessories

Benchtop housing

Reference THM



Option without keypad

Reference NBT
 Buttons are still available to the installer rear the filter.



DIN rail mount adapter

Reference DRA-M



Wall mount housing

Reference WME



Set of Units (included)

Reference Set of labels Units7

Description	Vdc	Vac	Adc
	Aac	mVdc	mVac
	mAdc	mAac	%
	°C	°F	ph
	m	cm	mm
	bar	psi	Pa
	N	Ω	KΩ
	W	kW	MW
	kV	kA	m/min
	rpm	l	(empty)

Option 'customized'

Customization of standard instruments

- improved technical performances
- custom configurations
- special functions
- ...



Other FEMA meters

Series B

4 and 6 digits

digit height 60 and 100 mm
 color red, green
 reading 25 and 50 meters
 formats B24, B26, B44, B46



Series M

4, 5 and 6 digits

digit height 14 mm
 color red, green
 reading 5 meters
 size 96 x 48 mm

DIGITAL PANEL METER
SERIES M
 Full Signal Ranges Available



Series K

Further view

digit height 20 mm
 color red
 reading 8 meters
 size 96 x 48 mm

DIGITAL PANEL METERS
SERIES K
 20 mm Digit Size



Series S

Compact size

digit height 14 mm
 color red, green
 reading 5 meters
 size 72 x 36 mm

DIGITAL PANEL METERS
SERIES S
 Compact Size 72x36 mm



Other signals

