

HEAVY INDUSTRY PRODUCTS AND SOLUTIONS



**ALL EQUIPMENT SOLUTIONS**

[allequipmentsolutions.com](http://allequipmentsolutions.com)



# // HI-VIS= ACTIVE DETECTION

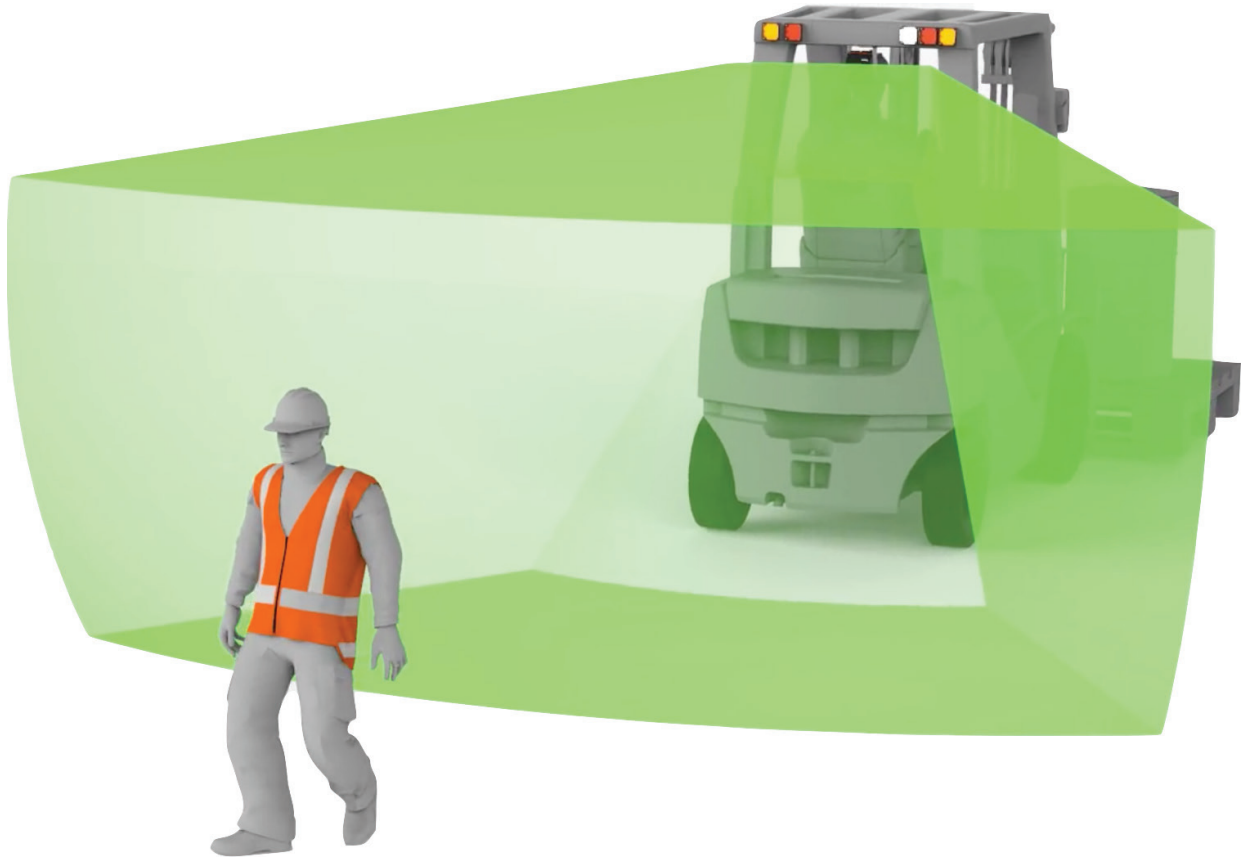

**IRIS 860 Sensor** is an effective safety solution that will enhance all safety programs!

- Easily installed on mobile equipment allowing effective detection of high-visibility clothing.
- Critical infrastructure and mobile equipment with high-visibility labeling will be identified by IRIS 860 sensors to minimize costly equipment damage.
- Reliable detection in dirty, wet, dusty, and poorly lit environments.



**AFFORDABLE**



**SIMPLE**



**EFFECTIVE**



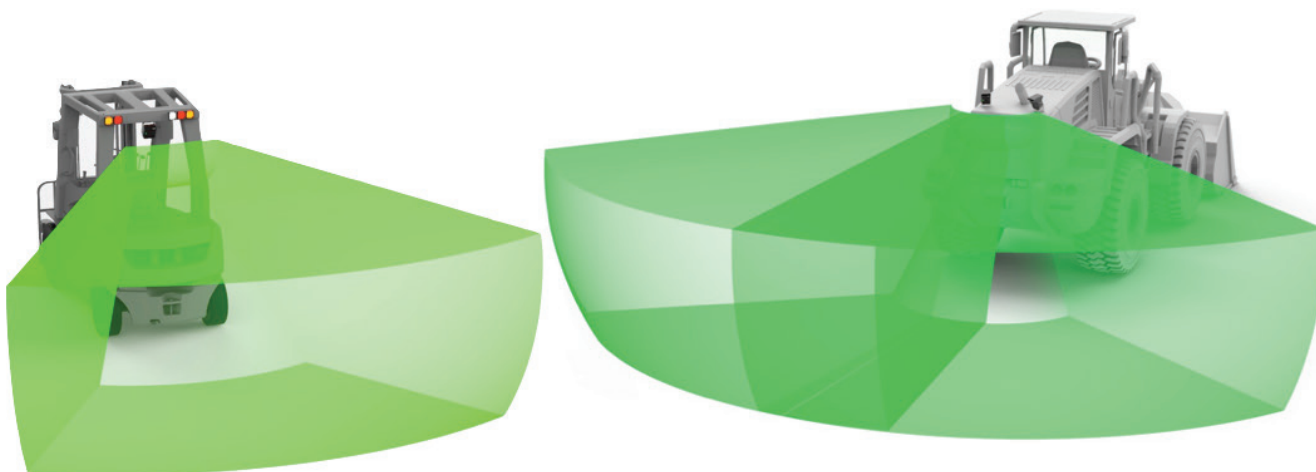

**IRIS 860 Sensor** has a 60° X 45° field of view, and can be attached anywhere on the machine, with a maximum detection range of 26 feet.

Multiple sensors can be used to achieve a 120° field of view. The detection area can be configured with two alert zones, a pre-alert zone (beeping audible alert), and the critical risk zone (continuous audible alert). The pre-alert gives the operator and pedestrian time to modify their behavior before they enter the critical risk zone.

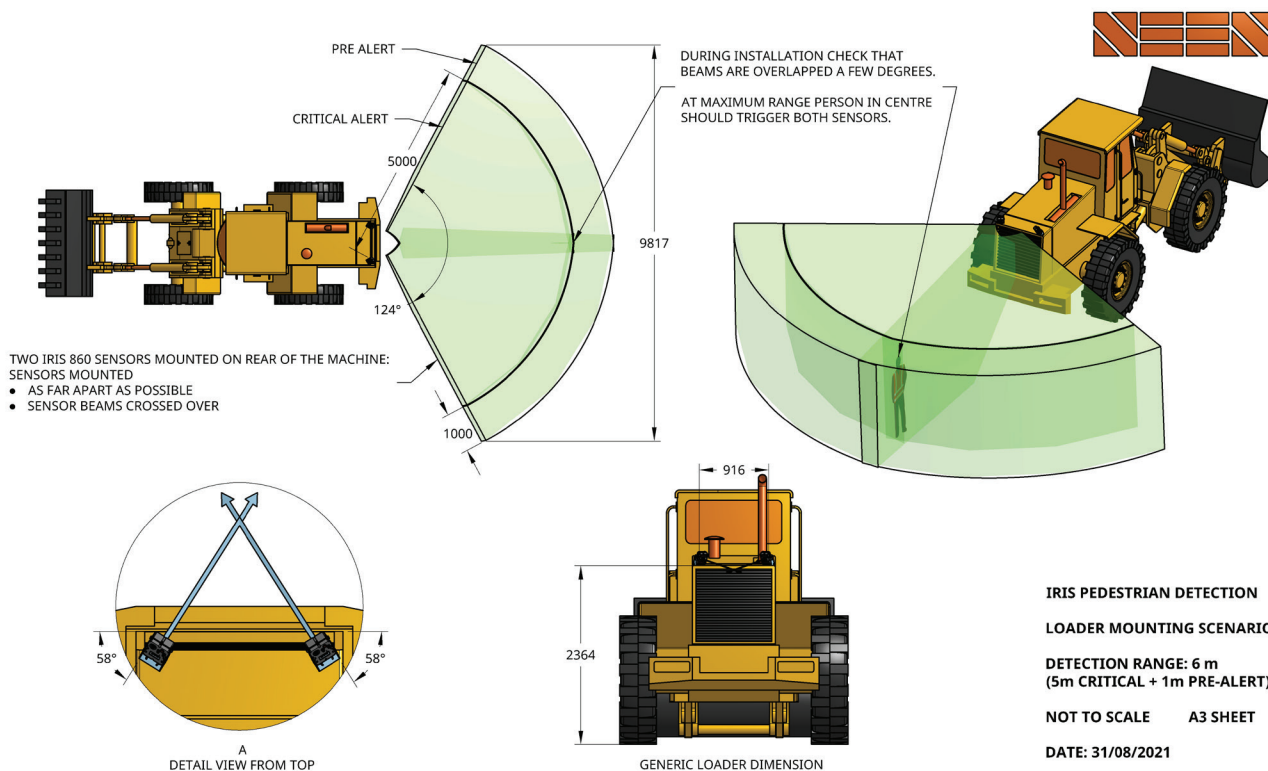

# // IRIS 860 + SAFETY INSIGHT

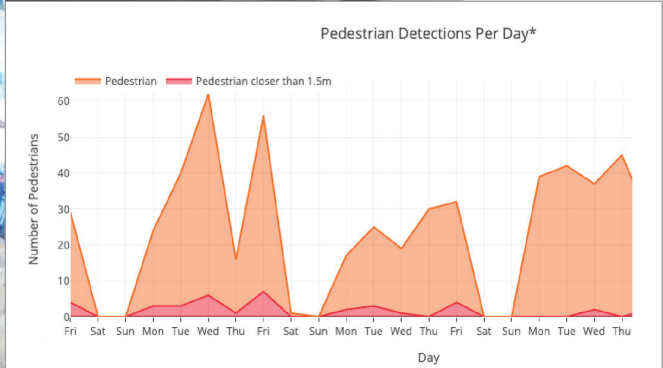
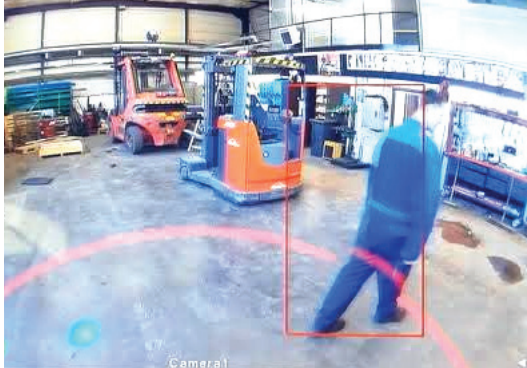

Pair the **IRIS 860 Sensor** with an **IRIS-i camera** for a reliable eyewitness when the sensor makes a detection.

The camera records the detection event, along with relevant data such as time, date, duration, and the detection distance. The data and video are uploaded to designated management via cellular network, providing valuable insights about near-miss accidents, pedestrian traffic patterns, and high-risk areas. This critical information enables swift continuous improvement to your safety program.





# MICRO BRIGHT™ BEACON



BE SAFE, BE SEEN //

## MICRO BRIGHT BEACON

The MicroBright Beacon is the most rugged, durable, and brightest available for industrial applications. MicroBright is your solution to safety alertness and awareness in your industry.



Sealed Flush Mount      Sealed Riser Mounts



Magnetic Mount      Pole Mount



DIN Pole Mount



MicroBright Beacon



Leading Competitor

Rugged	<input checked="" type="checkbox"/>	<input type="checkbox"/>
Compact	<input checked="" type="checkbox"/>	<input type="checkbox"/>
Brightest (Proven)	<input checked="" type="checkbox"/>	<input type="checkbox"/>
Made in:		
Most Expensive (Avg.)	<input type="checkbox"/>	<input checked="" type="checkbox"/>





**PERIMETERSAFE™**  
Focused Illumination Protection



## PERIMETER SAFE

PerimeterSAFE illuminates a perimeter around your machinery that will promote visibility, vehicle awareness, and identify NO-GO zones. Increased alertness will prevent accidents, equipment damage, and injuries.

Can be used in multiple applications: Delivery Trucks, Emergency Vehicles, Off Road Equipment, Road Construction Equipment, School Buses, Street Sweepers, and many more.







**PERIMETERSAFE™**  
Focused Illumination Protection

Each School Bus requires:  
2 x AIG005-FH-EX-4.5R  
1 x AIG005-FH-EX-UB



SCHOOL BUS ILLUMINATION

**Protect your school students who use the school bus in early morning/low light conditions!**

**Technical Specifications:**

Focused Illuminated Projection technology as exhibited by PerimeterSAFE zone lighting is not a laser or variation of laser technology.

Light Course: 2 x 3W LED

Producing: 18W

Color: Red

Operating Voltage: 10-80DCV

Certificate: E9/IP67

Material: housed in an aluminum die-cast housing, PC Cover,

Stainless Steel Bracket

Lifetime: >50,000hrs

Working Environment: -40degC-80degC

Regulatory Allowance & approval provided by:\*



*\*Does not constitute/imply endorsement of product.*

allequipmentsolutions.com





## Solutions

- ▶ Fleet Evaluation and Recommendations
- ▶ Equipment Sourcing
- ▶ Sell Your Equipment
- ▶ Mobile Equipment and Scrap Processing Equipment Valuation
- ▶ Maintenance Program Improvement Strategy

Exclusive Distributor of:



**AIGSAFETY™**  
Mobile Access & Safety Equipment



**ALL EQUIPMENT SOLUTIONS**  
LLC

**Len Lawrence**  
704.957.3991

**David Coslov**  
219.771.8602

[allequipmentsolutions.com](http://allequipmentsolutions.com)