

DATASHEET

Thermal Protector CYH

Type series YH

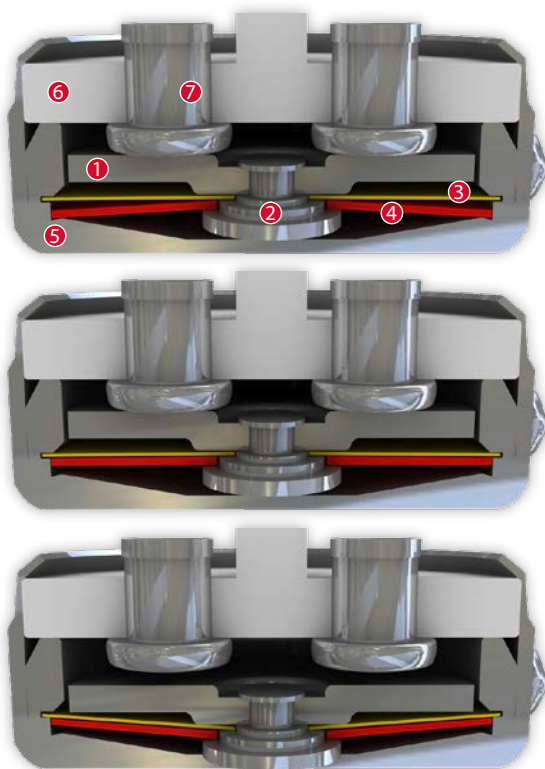

Construction and function

Switchgear consisting of a mobile and circumferential contact bridge (1), a contact bearing pin (2), a spring snap-in disc (3) and a bimetallic disc (4) which is riveted into one another, undetachable and fixed in a positive lock and self-aligning between the floor of a conductive housing (5) and an insulating ceramic bearing (6) with two integrated stationary contacts (7) as electrodes. At the same time, the switchgear is supported by the spring snap-in disc (3) with the contact bridge (1) acting as a transfer element for electric current which is held between a supporting collar and a circumferential ring. As such, the bimetallic disc (4) underlying it, that is also stuck out from the contact bearing pin (2), can continuously work (exposed) by mechanical loads without the contact pressure defined by the spring snap-in disc (3) diminishing. As soon as the bimetallic disc (4) reaches its rated switching temperature, it effectively springs against the throw force of the spring snap-in disc (3) into its inverted position. The contacts are abruptly opened. The temperature will now fall. The bimetallic disc (4) will only snap back upon reaching a defined reset temperature and the contacts will be abruptly closed again. As the contact bearing pin (2) is appropriately dimensioned, an easy, circular rotation of the circle-shaped contact bridge (1) is enabled with every switch so that transfer resistances remain constantly below the minimum limit after many switch cycles and the long term stability is sustained even under high levels of stress. Through an additional outer connection to the switch housing, the Thermal protectors can be operated in a three-phase arrangement. In this case the current flow is interrupted during operation through each phase.

Features:

Compact design with high pressure stability

For star connection

to use without any relay

Quick response sensitivity

featured by the metal housing and small protector mass

Excellent long term performance

due to fine silver contacts. Reproducible switching temperature values due to tempered, mechanically and electrically unstressed bimetallic disc

Very short bounce times

< 1 ms

Instantaneous switching

with always constant contact pressure up to the nominal switching point, resulting in low contact stress

Temperature resistance

by use of high temperature resistant materials and components

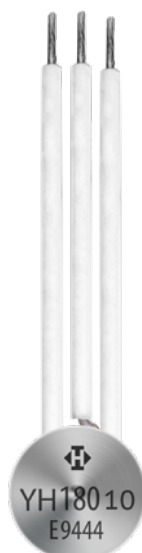

CYH

Type: Three-pole (normally closed) for three phase AC current use in the star point; resets automatically; with epoxy; without insulation

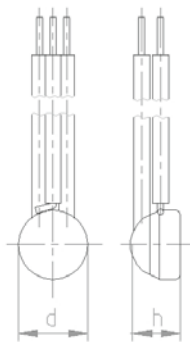
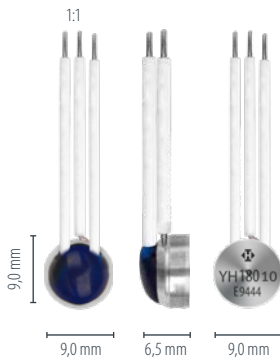

Installation height h from 6,5 mm
Diameter d 9,0 mm

Nominal switching temperature (NST) in 5 °C increments	70 °C - 180 °C
Tolerance (standard)	±10 K
Reverse Switch Temperature (defined RST is possible at the customer's request)	UL ≥ 35° C (≤ 95° C NST) -50 K ± 15 K (≥ 100° C ≤ 180° C NST)
Installation height	from 6,5 mm
Diameter	9,0 mm
Resistance to impregnation *	suitable
Suitable for installation in protection class	I
Pressure resistance to the switch housing *	600 N
Standard connection	Lead wire 1,0 mm ² / AWG18
Operating voltage range AC	up until 440 V AC
Rated voltage AC	3x 440 V 50/60 Hz
Rated current AC cos φ = 1.0/cycles	2,5 A / 10.000
Max. switching current AC cos φ = 1.0/cycles	12 A / 3.000
Total bounce time	< 1 ms
Contact resistance (according to MIL-STD. R5757)	≤ 50 mΩ
Vibration resistance at 10 ... 60 Hz	100 m/s ²

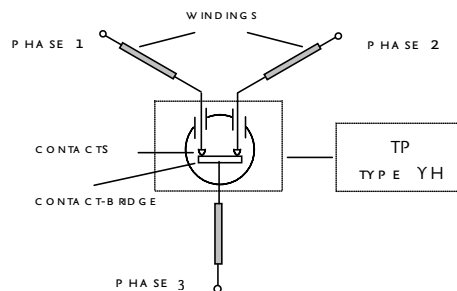

Ordering example:

CYH - 120. 10 0100 / 0100 / 0100
 Type / version ————
 NST [°C] ————
 Tolerance [K] ————
 Lead lengths [mm] ———— L₁ L₂ L₃

Marking example:

 thermik
 Trade mark ————
 Type / version ———— YH
 NST [°C] . Tolerance [K] — 120.10

More varieties of the type series YH:

• SYH – resets automatically; with epoxy; insulation: Mylar®-Nomex®

www.thermik.de/en/data/SYH

*In accordance with the Thermik test. Specifications relating to part applications (on the part of the buyer) which deviate from our standards are not checked for their capacity to support an application and/or conformity with standards. The responsibility for testing the suitability of Thermik products for such applications rests upon the user. - Slight deviations are possible in terms of dimensions/ values, depending on the embodiment of the product. - We reserve the right to make technical changes in the course of further development. - Details concerning certain data, measurement methods, applications, approvals, etc. can be supplied upon request.