

# DATASHEET

## Thermal Protector P06

### Type series 06

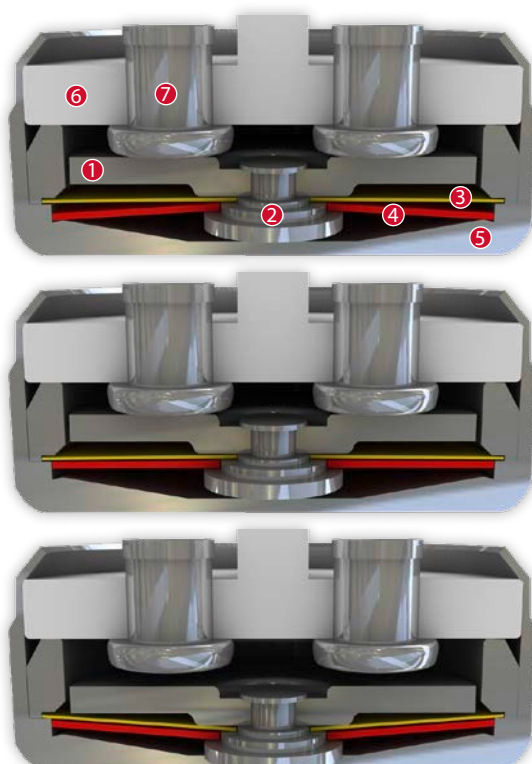

### Construction and function

Switchgear consisting of a mobile and circular contact bridge (1), a contact bearing pin (2), a spring snap-in disc (3) and a bimetallic disc (4) which is riveted into one another, undetachable and fixed in a positive lock and self-aligning between a non-conductive floor of a housing (5) and an insulating ceramic bearing (6) with two integrated stationary contacts (7) as electrodes. At the same time, the switchgear is supported by the spring snap-in disc (3) with the contact bridge (1) acting as a transfer element for electric current which is held between a supporting collar and a circumferential ring. As such, the bimetallic disc (4) underlying it, that is also stuck out from the contact bearing pin (2), can continuously work (exposed) by mechanical loads without the contact pressure defined by the spring snap-in disc (3) diminishing. As soon as the bimetallic disc (4) reaches its rated switching temperature, it effectively springs against the throw force of the spring snap-in disc (3) into its inverted position. The contacts are abruptly opened. The temperature will now fall. The bimetallic disc (4) will only snap back upon reaching a defined reset temperature and the contacts will be closed again. As the contact bearing pin (2) is appropriately dimensioned, an easy, circular rotation of the circle-shaped contact bridge (1) is enabled with every switch so that transfer resistances remain constantly below the minimum limit after many switch cycles and the long term stability is sustained even under high levels of stress.



### Features:

|                                 |  |
|---------------------------------|--|
| Contact opening                 | with constant distance of the contacts in the whole range between switching temperature and reset temperature                                    |
| Ceramic deck-plate              | as contact-carrying part   |
| Very short bounce time          | < 1 ms   |
| Instantaneous switching         | with always constant contact pressure up to the nominal switching point, resulting in low contact stress   |
| Excellent long term performance | due to fine silver contacts; reproducible switching temperature values due to tempered, electrically and mechanically unstressed bimetallic disc |

P06

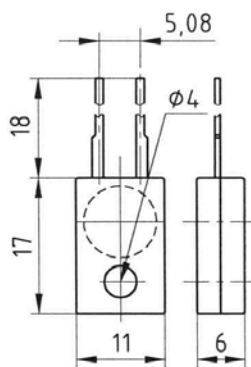
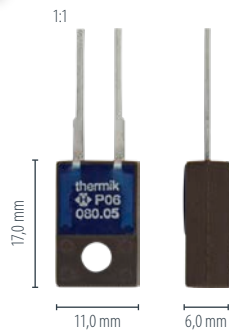

|                               |                   |
|-------------------------------|-------------------|
| Installation height h         | from 6,0 mm       |
| Housing size (length/width)   | 17,0 mm / 11,0 mm |
| Length of the connection pins | 18,0 mm           |
| Fixing/Max. torque            | 3,0 Nm            |

Type: Normally closed; resets automatically; with connection pins; with epoxy; fully insulated in the attachment housing

|  |                              |                                      |
|--|------------------------------|--------------------------------------|
| Nominal switching temperature (NST) in 5 °C increments                         | 70 °C - 200 °C               |                                      |
| Tolerance (standard)   | ±5 K                         |                                      |
| Reverse Switch Temperature (defined RST is possible at the customer's request) | UL                           | ≥ 35° C (≤ 95° C NST)                |
|  |                              | -50 K ± 15 K (≥ 100° C ≤ 180° C NST) |
|  |                              | -65 K ± 15 K (≥ 185° C ≤ 200° C NST) |
|  | VDE                          | ≥ 35 °C                              |
| Installation height  | from 6,0 mm                  |                                      |
| Housing size (length/width)  | 17,0 mm / 11,0 mm            |                                      |
| Length of the connection pins  | 18,0 mm                      |                                      |
| Fixing/Max. torque   | 3,0 Nm                       |                                      |
| Resistance to impregnation *   | suitable                     |                                      |
| Suitable for installation in protection class                                  | I + II                       |                                      |
| Pressure resistance to the switch housing *                                    | 600 N                        |                                      |
| Available approvals (please state)   | IEC; ENEC; VDE; UL; CSA; CQC |                                      |
| Operational voltage range AC/DC  | up until 500 V AC / 28 V DC  |                                      |
| Rated voltage AC   | 250 V (VDE) 277 V (UL)       |                                      |
| Rated current AC cos φ = 1.0/cycles  | 10,0 A / 10.000              |                                      |
| Rated current AC cos φ = 0.6/cycles  | 6,3 A / 10.000               |                                      |
| Max. switching current AC cos φ = 1.0/cycles                                   | 25,0 A / 100                 |                                      |
| Rated voltage DC   | 24 V                         |                                      |
| Max. switching current DC/cycles   | 40,0 A / 3.000               |                                      |
| High voltage resistance  | 2,0 kV                       |                                      |
| Total bounce time  | < 1 ms                       |                                      |
| Contact resistance (according to MIL-STD. R5757)                               | ≤ 50 mΩ                      |                                      |
| Vibration resistance at 10 ... 60 Hz   | 100 m/s <sup>2</sup>         |                                      |

Current sensitivity characteristic at I<sub>nom</sub>:

dependent of...

- Thermal coupling
- Application area
- Built-in conditions
- Outer influences
- Wiring length / wiring diameter

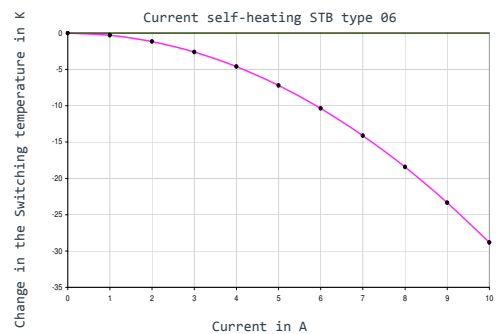

\*In accordance with the Thermik test - Specifications relating to part applications (on the part of the buyer) which deviate from our standards are not checked for their capacity to support an application and/or conformity with standards. The responsibility for testing the suitability of Thermik products for such applications falls upon the user. - Slight deviations are possible in terms of dimensions/ values, depending on the embodiment of the product. - We reserve the right to make technical changes in the course of further development. - Details concerning certain data, measurement methods, applications, approvals, etc. can be supplied upon request.

Ordering example:

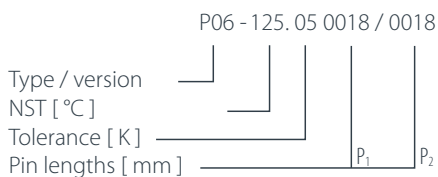

Marking example:



More varieties of the type series 06:  
[www.thermik.de/en/products/baureihen-en/06/](http://www.thermik.de/en/products/baureihen-en/06/)