

DECLARATION OF CONDOMINIUM

OF

OCEAN VILLAS CONDOMINIUM

OFF REC 565 PAGE 538

82 17438

KNOW ALL MEN BY THESE PRESENTS THAT:

OCEAN VILLAS CONDOMINIUM INVESTORS, LTD., a Florida limited partnership (the "Developer"), hereby submits to condominium ownership pursuant to Chapter 718, Florida Statutes, as amended (the "Condominium Act"), the land and all improvements now existing thereon and/or hereafter erected thereon all equipment, furnishings, and fixtures now or hereafter located thereon (herein the "Property"), located in St. Johns County, Florida, and more particularly described as follows:

See Attached Exhibit "A"

The Property and any additional property added to the condominium by amendment to this Declaration, shall hereafter be known as Ocean Villas Condominium and shall be subject to provisions, restrictions, reservations, covenants, and conditions and easements hereinafter set forth, all of which shall constitute covenants running with the land, binding upon owners and lessees of any part of the Property, and their heirs, successors, administrators and assigns.

ARTICLE I

DEFINITIONS

1. Association is Ocean Villas at St. Augustine Beach Condominium Association, Inc., a non-profit Florida corporation

EXHIBIT II

organized to administer this condominium. A copy of the Articles of Incorporation is attached hereto as Exhibit "B" OFF REC 565 PAGE 539

2. Dwelling Unit is a Unit as defined by the Condominium Act, subject to the boundary description in Article II of this Declaration. Unless otherwise stated, the term Unit used herein means a Dwelling Unit.

3. Condominium Parcel is a Dwelling Unit in this condominium together with the undivided interest in the Common Elements appurtenant thereto and an undivided share in the Common Surplus, and includes an obligation to bear a portion of the Common Expenses.

4. Owner is the person or entity owning in fee simple a Condominium Parcel.

5. Condominium Property is all of the property subjected to condominium ownership.

6. Common Elements are all of the Condominium Property except the Dwelling Units and shall include but not be limited to:

(a) All improvements and parts of the Condominium Property not included within a Unit, which do not serve a particular Unit;

(b) Easements through the Unit for conduits, ducts, plumbing, wiring and other facilities for furnishing utility services to the various Units and to the Common Elements;

(c) All structural beams, posts and members within a Unit and an easement of support in every portion of a Unit which contributes to the support of the building;

OFF REC 565 PAGE 540

(d) All utility lines, equipment and installations which serve more than one Unit or the Common Elements;

(e) All parking areas, driveways, sidewalks and entranceways and all other means of egress and ingress to the Condominium Property;

(f) All electrical appliances, apparatus and wiring, plumbing, pipes and apparatus, telephone wires, and all other ducts, conduits, cables, wires or pipes (except television cables) which are outside of the boundaries of the Units; and

(g) All personal property located on the Property used for the maintenance and operation of the condominium and for the common use and enjoyment of the Owners except personal property owned by Unit Owners.

7. Common Expenses are:

OFF REC 565 PAGE 541

(a) Expenses of administration, insurance, maintenance, operation, repair and replacement of the Common Elements and of the portions of the Units to be maintained by the Association and costs of carrying out the powers and duties of the Association, including professional fees and expenses.

(b) Expenses declared Common Expenses by provisions of this Declaration or the Bylaws.

(c) Any valid charge against the Condominium Property as a whole.

8. Common Surplus is all amounts held by the Association in excess of estimated current operating expenses and reserve funds.

9. Board of Directors is the Board of Directors of the Association which shall have the powers and duties specified in the Bylaws of the Association, a copy of which is attached hereto as Exhibit "C".

ARTICLE II

DESCRIPTION OF CONDOMINIUM; PHASES

The Developer is constructing the seventy-two (72) Units described in Article IV hereof and in Exhibit A on the land described in Exhibit A. Twenty-four units will be two bedroom, two bath flats with approximately 1200 square feet. Forty-eight units will be two bedroom, two bath townhouses with approximately

1200 square feet. Phase I has commenced and will be completed April 13, 1983. Developer reserves the right to expand the condominium at any time prior to December 31, 1989 to add Phase II, which is shown on Exhibit E. Phase II will, if built, contain sixty-six (66) Units. Twenty-two will be two bedrooms, two bath, flats with approximately 1200 square feet. Forty-four will be two bedroom, two bath townhouses, with approximately 1200 square feet. If Phase II is added, each Unit will have as an appurtenance thereto an equal share with all other Dwelling Units in the Common Elements.

Phase II may be added at any time prior to December 31, 1989 without consent of any Unit Owner or any mortgagee of a Unit by executing and recording an amendment to this Declaration adding the Phase as described on Exhibit E.

ARTICLE III

OWNERSHIP OF UNITS AND BOUNDARIES

3.1 Each Unit together with all appurtenances thereto, shall, for all purposes, constitute a separate parcel of real property which may be owned in fee simple and which may be conveyed, transferred and encumbered in the same manner as any other parcel of real property subject only to the provisions of the Condominium Documents and other covenants, restrictions and easements of records. Each Owner shall be entitled to exclusive possession of his Unit subject to the provisions of the Condominium Documents.

3.2 The boundaries of each Unit shall be determined as follows:

(a) The upper horizontal boundary shall be the lower surface of the unfinished ceiling of the uppermost level of each part of the Unit.

OFF REC 565 PAGE 543

(b) The lower horizontal boundary shall be the plane or upper surface of the unfinished floor of the lowest floor level of each part of the Unit.

ARTICLE IV

UNITS AND APPURTENANCES

The Units are identified below by number. Each Unit shall include the following as appurtenances, whether or not separately described, which shall pass with that Unit whenever it is conveyed:

4.1 Common Elements, Common Surplus and Common Expenses.

Each Condominium Parcel shall include an undivided interest in the Common Elements and the Common Surplus as provided below and shall bear the same proportion of the Common Expenses as its ownership interest in the Common Elements and Common Surplus:

Dwelling Units. Each Dwelling Unit now included or hereafter added to this Condominium shall own an equal interest in the Common Elements and the Common Surplus. The Units initially included in this Condominium are Units One (1) through seventy-two (72) inclusively as shown on Exhibit A.

Each Owner, the Developer and the Association may use the Common Elements for the purposes for which they are maintained but no such use shall hinder or encroach upon the lawful rights of other Owners. The Common Elements shall remain undivided and no Owner or any other person shall bring any action for partition or division of the whole or any part thereof. Shares of Owners in the Common Elements as stated in this Declaration may be altered only by amendment of the Declaration executed by all the Owners of Units in the Condominium. No such change shall materially affect the lien of a prior recorded mortgage without the consent of the mortgagee.

4.2 Membership in the Association. Ownership of a Unit shall entitle the Owner to membership in the Association and an interest in the funds and assets of that corporation equal to his percentage interest in the Common Elements.

4.3 Voting Rights. Each Owner shall have a vote in the Association equal to the number of Dwelling Units he owns.

4.4 Easements. Each unit shall have as an appurtenance, the following easements.

(a) An exclusive easement for the use of the air space occupied by the Unit as it exists in any particular time.

(b) Easement through all Common Elements for ingress, egress, maintenance, repair and replacement.

(c) Easements through Units for maintenance, repair and replacement of the Unit and Common Elements and for other necessary purposes. Such access shall be only during reasonable hours except in case of emergency.

ARTICLE V

DEVELOPER'S UNITS AND PRIVILEGES

5.1 Right to Own and Sell. Notwithstanding anything herein to the contrary, the Developer (which term shall include its officers and directors) has the irrevocable power to sell, lease or rent Units to any person. Developer shall have the right to transact on the Condominium Property any business necessary to consummate the sale, lease or rental of Units, including but not limited to the right to maintain models, have signs, maintain an office and employees on the Property and use the Common Elements to show Units. A sales and rental office, signs and all items pertaining to sales and rentals shall not be considered Common Elements and shall remain the property of the Developer.

5.2 Assessments Against Unbuilt or Unsold Units.

(a). The Developer shall be excused from payment of his share of the common expense

assessed against those units of the condominium owned by the Developer subsequent to recordation of this Declaration of Condominium. However, the period during which the Developer is excused from payment of Common Expenses shall terminate no later than the first day of the fourth calendar month following the month in which the closing of the purchase and sale of the first condominium unit occurs.

(b) During the time period the Developer is excused from payment of Common Expenses assessed against units in the Condominium, Developer shall pay the portion of Common Expenses incurred which exceed the total amount of Common Expenses assessed against other unit owners.

5.3 Right to Change, Divide or Combine Units. The Developer reserves the right to change the interior design

and arrangement of, and to divide or combine one or more Units or portions thereof at any time prior to the sale of such Units by the Developer, provided that the share of the Common Elements, Expenses and Surplus applicable to such divided or combined Units shall include all of the shares of ownership interest in the Common Elements and Surplus attributed to the Units affected.

5.4 Easement for Access and Utilities. The Developer expressly reserves a perpetual easement for ingress and egress for all utility installation and maintenance over, across and under all the roadways and parking areas as shown on Exhibit A.

5.5 Developer's Right to Manage. Developer hereby reserves unto itself the right to manage all of the affairs of this Condominium and all of the affairs of the Association including naming all directors and officers of the Association as long as the Developer owns more than eighty-five percent (85%) of the Units in the Condominium. Thereafter, the Unit Owners shall be entitled to elect directors of the Association as specified at this time in Section 719.301, Florida Statutes.

5.6 Prohibited Actions. So long as the Developer is the Owner of record title to any Unit, and holds that Unit for sale in the ordinary course of business, none of the following actions may be taken without approval in writing from the Developer:

- (a) Assessments of the Developer as a Unit Owner for capital improvements;
- (b) Any action that would be detrimental to the sale of Units by the Developer; provided, however, that a uniform increase in assessments for common expenses without discrimination against the Developer shall not be deemed detrimental.

ARTICLE VI

THE ASSOCIATION

6.1 Duties. The Association shall administer, manage, maintain and repair the Condominium and the Condominium Property (except for the portions of Units to be maintained and repaired by Owners).

6.2 Members and Voting. All persons owning a vested present interest of record in the fee title to any Condominium Parcel shall automatically be members of the Association and their respective membership shall terminate as their vested interest in the fee title to the Condominium Parcel terminates. Membership in the Association cannot be transferred, assigned or pledged in any manner except as an appurtenance to the respective unit.

6.3 Powers. Each owner shall be entitled to one vote in the Association for each Condominium Parcel owned by him, which shall be exercised only by that Owner or his proxy. If a person owns more than one Unit, he shall be entitled to one vote for each Unit owned. In the event a Unit is owned by more than one person or by a corporation, trust or other entity, the individual entitled to cast the vote for that Unit shall be designated by a certificate filed with the Secretary of the Association and signed by all joint owners of the Unit or by an authorized agent of the corporation or other entity. The Association has all of the rights and powers available to a non-profit corporation under the laws of the State of Florida, and the powers created by the Condominium Act, the rights, powers and duties accorded to it by this Declaration

6.4 Expenses. All expenses of the Association shall be assessed as Common Expenses of the Owners, as provided in the Bylaws.

ARTICLE VII

MAINTENANCE, ALTERATION AND REPAIR

The responsibility of the maintenance and repair of the Condominium Property shall be as follows:

7.1 Association. The Association shall maintain, repair and replace:

(a) All Common Elements, including but not limited to all boundary walls of the Units except interior surfaces, all portions of the Unit contributing to the support of the building,

the outside walls of buildings, floor and ceiling slabs, load bearing walls, and floor slabs of patios, and all fixtures on the exterior.

(b) All conduits, ducts, plumbing, wiring and other facilities for the furnishing of utility services to the Units, except those facilities which are the responsibility of the Owners to maintain, and all facilities contained within a Unit that service parts of the condominium other than Units in which they are contained.

(c) All other items which the Board of Directors of the Association determines shall be maintained, repaired or replaced by the Association in accordance with uniform policies, consistently applied.

The Association shall have access to each Unit during reasonable hours as may be necessary for repair or maintenance of any Common Elements located therein or accessible therefrom and shall have such rights of access in emergencies as are necessary to prevent damage to a Unit or to the Common Elements.

7.2 Owner. The Owner shall:

(a) Maintain, repair and replace all portions of each Unit except the portions to be repaired and replaced by the Association. The areas to be maintained by the Owners shall include but not be limited to:

(i) Heating and air-conditioning equipment within the Unit, and the ducts, pipes, wiring, controls, and

other apparatus serving only that Unit, even though located outside the Unit boundary.

OFF REC 565 PAGE 551

(ii) All kitchen and bathroom fixtures, apparatus and equipment

(iii) All electrical, plumbing, telephone and television fixtures, apparatus, equipment, outlets; switches, wires, pipes, and conduits within the unfinished surfaces of the boundary walls of the Unit, and any such items serving only one Unit, even though located outside the Unit boundary

(iv) All doors within the Unit including those which open to the Unit from an entranceway or the outside, interior walls and partitions, wall decorations and built-in furniture, windows, and window apparatus and glass, sliding glass doors, screens and screen supports.

(b) Not install any mechanical equipment which causes annoyance to the occupants of other Units.

(c) Not paint or otherwise decorate or change any portion of the exterior of the Unit building.

(d) Promptly report to the Association any defects or need for repairs for which the Association is responsible.

If the Owner shall fail to commence and diligently pursue the maintenance and repair required by this paragraph within ten (10) days after receiving written notice of his failure to do so from the Association, the Association shall have the right to make such repairs, maintenance or replacement at the expense of the Owner. If the Owner fails to reimburse the Association for such expenses upon demand, the Association shall have a lien for such expenses upon that Owner's Condominium Parcel.

7.3 Alterations and Improvements. Neither an Owner nor the Association nor any other party (except the Developer as specifically set forth herein) shall make any alteration or additions or removals in the portions of a Unit that are to be maintained by the Association or do anything that will jeopardize the safety or soundness of the building or impair any easements without first obtaining unanimous approval in writing of the Owners and mortgagees of record of all Units in which such work is to be done and of the Board of Directors of the Association. A copy of plans for such work prepared by an architect licensed to practice in Florida shall be filed with the Association prior to the start of any such work, the cost of which exceeds \$5,000.00. Alterations, additions or removals to the Common Elements may be made upon the approval of the Owners of two-thirds (2/3) of the votes in the Association

7.4 Reconstruction or Repair After Casualty.

OFF REC 565 PAGE 553

(a) Determination of Reconstruct or Repair. If any part of the Condominium Property shall be damaged by casualty or taken by Eminent Domain, the Board of Directors shall determine as to each Unit whether or not it is tenantable after the casualty. If Units to which fifty percent (50%) or more of the Common Elements are appurtenant are found to be tenantable, the damaged property shall be reconstructed or repaired as provided herein. If Units to which less than fifty percent (50%) of the Common Elements are appurtenant are found to be tenantable, the Board of Directors shall:

- (i) Obtain reliable and detailed estimates of the costs to rebuild or repair, and the amount of insurance proceeds available to pay such costs.
- (ii) Give all Owners notice of the casualty, specifying the above information, and calling a meeting of Owners to be held within thirty (30) days from the date of the notice.

At the meeting, the Owners shall consider whether to repair or replace the damage or to terminate the Condominium. If Owners of sixty-six and two-thirds percent (66-2/3%) of the votes

of the Association vote to repair or replace the damaged property, it shall be repaired or replaced. Otherwise, the Condominium shall be terminated without agreement as provided in Article VIII, Paragraph 1.

(b) Responsibility. The responsibility for reconstruction and repair after casualty, shall be the same as for maintenance and repair of the Condominium Property and the Association shall have the same rights as therein provided (Article VII, Paragraph 2) to make repairs which are the responsibility of an Owner if that Owner fails to do so.

(c) Proceeds. If the damage or taking is to be repaired, the Association shall make available the proceeds of insurance or from Eminent Domain as provided herein to repair or replace the damage. If the proceeds are not sufficient to reconstruct and repair the damaged property, assessments shall be made against the Owners responsible for the repair, in sufficient amounts to provide funds for payment of such costs. Assessments for repair of a particular Unit shall be made against the Owner of that Unit. Assessments for repair of Common Elements shall be made against Owners in proportion to each Owner's share in the Common Elements.

(d) Disbursements of Funds. If the amount of the estimated costs of reconstruction and repair is less than \$10,000.00 and does not involve damage to structural parts of a building, the Board of Directors shall disburse funds for repair

(insurance proceeds plus assessments) immediately upon their receipt. If the amount is \$10,000.00 or more, or involves damage to structural parts of a building, funds shall be disbursed by the Board of Directors:

- (i) Only after the Board of Directors has approved the contractor to perform the repair work and the terms of the repair contract;
- (ii) Only to the extent that work is, in the judgement of the Board of Directors, satisfactorily completed.

Funds to repair damages for which the individual Owner is responsible shall be disbursed directly to that Owner, unless there is a mortgagee endorsement as to any part of the insurance proceeds in which event such insurance proceeds shall be disbursed jointly to the Owner and the mortgagee. All such disbursements shall be received in trust for use in the repair or replacement of the damaged Unit. All funds to repair damage for which the Association is responsible shall be disbursed directly by the Association for such repairs or replacements.

It shall be presumed that the first money disbursed in payment of costs of reconstruction and repair shall be from insurance proceeds. If funds remain after payment of all costs of the reconstruction and repair, they shall be distributed to the

beneficial owners, except that distributions of insurance proceeds to Owners whose mortgagees have a mortgage endorsement as to the insurance proceeds shall be made payable jointly to the Owner and the mortgagee.

ARTICLE VIII

INSURANCE

The Association shall obtain and maintain policies of insurance covering the Condominium Property and the real property of the Unit Owners. Subject to the following, the Board of Directors shall have discretion in obtaining such policies:

8.1 Casualty Insurance. The Association shall obtain casualty insurance covering all buildings, improvements and personal property included in the Common Elements in an amount equal to its maximum insurance value, if desirable, with deductible provisions against loss or damage by fire and other hazards covered by standard fire and extended coverage policies and such other risks including, but not limited to, flooding, vandalism and malicious mischief and such other insurance for the Association as is desirable.

8.2 Public Liability Insurance. The Association shall obtain insurance insuring the Association and each owner against liability for accidents occurring on any of the Condominium Property.

8.3 Premiums. Premiums for insurance policies purchased by the Association shall be paid by the Association as a Common

Expense, except that any increase in premiums caused by use of a Unit for purposes other than as a residence, or by misuse, occupancy or abandonment of a Unit shall be assessed against the responsible Owner. If requested to do so, the Association shall furnish evidence of payment of premiums to Owners or mortgagees.

8.4 Proceeds. All proceeds of insurance policies purchased by the Association shall be payable to the Association and the Unit Owners. The Association shall hold the proceeds it receives in trust, to be distributed as provided herein.

8.5 Association as Agent. The Association is irrevocably appointed agent for each Owner and for each mortgagee or other lienholder and for each owner of any other interest in the Condominium Property to adjust all claims affecting the Common Elements arising under insurance policies purchased by the Association and to execute and deliver releases upon payment of claims.

8.6 Notice of Actions. If any action shall be brought against the Association which might result in a judgment for an amount greater than the insurance coverage carried by the Association, then the Association shall promptly notify the Unit Owners and they shall have the right to intervene and defend their interest.

ARTICLE IXCOMMON EXPENSES: ASSESSMENTS AND LIENS

9.1 Common Expenses. Each Unit Owner shall pay his portion of the Common Expenses for the Condominium and the Association.

9.2 Budget. The Board of Directors shall approve annual budgets of projected expenses for each fiscal year and assess each Owner for his proportionate share of such expenses; provided, however, that so long as the Developer is in control of the Board, it shall not, without the consent of a majority of Unit Owners, impose an assessment for any year which is greater than one hundred fifteen percent (115%) of the amount for the previous fiscal year.

9.3 Payment. Each Unit Owner's assessment for his Condominium Parcel shall be due and payable to the Association in twelve (12) equal monthly installments in advance unless some other less frequent payment schedule is adopted by the Board of Directors. If necessary to cover unanticipated expenditures which may be incurred during the fiscal year, the Board of Directors may levy special assessments against Unit Owners in proportion to their share of the Common Expenses. In addition, the Board of Directors may assess Owners for certain expenses attributable solely to their Unit. Such assessments may be for costs specifically provided herein (such as reconstruction or repair after casualty) or may be in the discretion of the Board of Directors.

9.4 Liens and Late Charges. Any assessments provided for in this Declaration which are not paid when due shall bear interest from the due date until paid at the maximum rate allowed by law or such lower rate as the Board of Directors shall determine, shall be subject to a late charge as may be set and uniformly applied by the Board of Directors and shall entitle the Association to an attorney's fee in the collection thereof. The Association shall have a lien on each Condominium Parcel as provided in Section 718.116, Florida Statutes, and any amendments thereto for any assessment, interest, late charge, expenses, and attorney's fees provided for in this Declaration. Such liens shall not attach until a notice of lien is recorded in the public records of the County in which the Property is located, and a copy thereof is furnished to the record Owner of the Condominium Parcel. In addition, the Association shall have all other remedies provided by the Condominium Act and other applicable laws for the collection of the above, or the enforcement of its lien. The Board of Directors may require Owners to maintain a minimum balance on deposit with the Association for working capital and other contingent expenses.

ARTICLE X

USE RESTRICTIONS

The Condominium Property shall be used for residential purposes only, subject to the following:

10.1 Lawful Use; Nuisances. All Owners and occupants of Dwelling Units shall comply with all applicable laws, ordinances and regulations of all governmental bodies having jurisdiction over the Condominium Property. No nuisances shall be allowed on the Condominium Property, nor any use or practice which annoys or interferes with residents. No loud or objectionable noises or odors which may disturb adjacent Units shall be permitted. All parts of the Condominium Property shall be kept in a clean and sanitary condition, and no rubbish, refuse or garbage allowed to accumulate, nor any fire hazard allowed to exist. No Owner shall make or permit any use of his Condominium Parcel which will increase the rate of insurance upon the Condominium Property.

10.2 Dogs. All dogs which are outside of a Unit shall at all times be on leashes and accompanied by their Owner. Dogs may be curbed only in designated areas. The size and number of dogs may be controlled by rules and regulations.

10.3 Parking. All parking areas and all driveways shall be used only for parking and driving. No boats, trailers, trucks or recreational vehicles may be kept or stored in any such areas without the prior written approval of the Association.

10.4 Rules and Regulations. The Board of Directors shall adopt reasonable rules and regulations for the use of the Condominium Property which may be amended from time to time, provided that the rules and regulations do not conflict with this Declaration or the Bylaws of the Association. The Association shall furnish copies of the rules and regulations to all Owners and residents of the Condominium. The Board of Directors may enforce

the regulations by reasonable means including imposing fines which shall become assessments against the Unit Owners. All Owners and residents shall abide by the rules and regulations and Bylaws of the Association. The Board of Directors or its designated agent shall have the right, without a breach of the peace, to enter any Unit after reasonable advance notice at any reasonable time to determine compliance with the Condominium Act, this Declaration, the Bylaws and the regulations of the Association.

10.5 Signs. No signs, other than those of Developer, shall be displayed from a Unit or on the Common Elements except those which have advance written approval from the Association.

ARTICLE XI

TRANSFER OF UNITS

To maintain the Condominium as a community of congenial residents, the transfer of all Units, other than those owned by the Association or the Developer, its officers or directors, shall be subject to the following restrictions:

11.1 Transfers Subject to Approval. All transfers of a Condominium Parcel or any interest therein (including without limitation sales, leases, assignments or other transfers) shall be subject to the approval of the Association, which shall act through the Board of Directors, except the following:

- (a) Transfer of a Condominium Parcel of interest therein by gift without consideration; and
- (b) Transfer of a Condominium Parcel of interest therein by devise or intestate succession.

11.2 Notice. An Owner desiring to sell, convey, lease for a period of more than one (1) year, or otherwise transfer his Condominium Parcel (the Transferring Owner) shall first give the Board of Directors written notice of the proposed transfer specifying the name and address of the intended transferee, his business or occupation, financial and character references, the terms of the proposed transfer including copies of contracts providing for the transfer, and such other information as the Board of Directors may reasonably request (all such information is herein called the "Notice").

11.3 Options of Association. The Board of Directors have thirty (30) days from receipt of the Notice to hold a meeting and either approve or disapprove the transfer. If the transfer is approved, the Board shall promptly furnish a certificate of approval to the Transferring Owner and the transaction shall be consummated as stated in the Notice. If the transaction is not so consummated, then the approval shall terminate. If the Board disapproves the transfer, the Association shall have the following options:

(a) If the proposed transfer is a sale, the Association shall either purchase the Transferring Owner's interest in the Parcel upon the same terms as provided in the Notice or assign such right to a third party.

(b) If the proposed transfer is a lease, assignment or transfer other than a sale, the Association may acquire the

Transferring Owner's interest on the same terms as stated in the Notice, assign its rights to acquire the Transferring Owner's interest or require that the transfer not be made.

Upon election of its options, the Board of Directors shall give written notice of its election to the Transferring Owner. If the election is other than that a transfer other than a sale not be made, the transfer to the Association or its assignee shall be closed within thirty (30) days thereafter, or on such later date for closing as may be specified in the Notice, upon the same terms as stated in the Notice. The Board of Directors shall have authority to obtain a mortgage or other financing to make assessments proportionately upon the Owners and to do other acts as may be necessary to close and consummate the transfer of the Condominium Parcel to the Association.

11.4 Failure to Notify. If the Board of Directors fails to give the Transferring Owner any notice within thirty (30) days after it receives the Notice, the Transferring Owner may proceed to close the proposed transfer with the named transferee only, at any time within the next ninety (90) days at the price and on the terms stated in the Notice. The Board shall within a reasonable time after the transfer furnish to the transferee a certificate of approval of the transfer which he may record in the public records of the county in which the property is located, at his expense. If the Transferring Owner fails to close the transaction within the ninety (90) day period, upon the terms stated in the Notice, his Condominium Parcel shall again become subject to the Association's right of approval as herein provided.

11.5 Form of Documents; Association Expenses. No Owner shall enter into any contract or other document providing for transfer of any interest in a Unit unless such document specifically provides that the transfer is subject to the rights of the Association contained in this Article, and further provides that the contracting parties shall indemnify the Association against any costs or expenses, including reasonable attorney's fees at trial or upon appeal, incurred by the Association and arising out of such documents, or disputes relating thereto. If any Owner fails to include such provisions in any contract or other document, that Owner shall so indemnify the Association, and the Association shall have a lien upon that Owner's Unit for its costs and expense, including reasonable attorneys fees at trial or upon appeal.

All deeds, leases or other instruments by which any interest in a Condominium Parcel is transferred in a transaction subject to this Article shall expressly provide that the transferee shall comply with all the rules and regulations of the Association and the terms of this Declaration so long as he owns any interest in the Condominium Parcel, and that he shall not sell, lease or otherwise transfer his interest in the Condominium Parcel without first granting to the Association the same rights as are contained herein.

11.6 Costs. No fees shall be charged in connection with approval or disapproval of any transfer of a Unit, except that an

Owner required to give the Notice, may be required to pay the expenses of the Association in obtaining a credit report upon the prospective purchaser. Such expenses for which the Owner is responsible shall not exceed fifty dollars (\$50.00).

11.7 Unauthorized Transactions. If any Owner shall attempt to transfer any interest in his Condominium Parcel without complying with the foregoing provisions, the Association shall have all of the remedies provided herein or under the laws of the State of Florida, including without limitation, the right to specific performance of the right of first refusal, and the right to injunctive relief preventing the proposed transfer. The Association shall also have the right to purchase or acquire the transferred interest from the new Owner, upon the same terms and conditions as those by which the new Owner acquired such interest. If the Association elects to exercise this right, it may require the purchaser or lessee to convey his interest in the Condominium Parcel to the Association or its duly selected assignee, upon the terms and conditions herein set forth.

11.8 Exceptions. The foregoing provisions of this Article shall not apply to a transfer to or purchase by a mortgagee of record which acquires its title as the result of foreclosure of a mortgage, whether the title is acquired by deed from the mortgagor, his successors or assigns, or through foreclosure proceedings; nor shall such provisions apply to a transfer, sale or lease by

that mortgagee. In addition, the foregoing provisions shall not require approval of a purchaser who acquires title to a Condominium Parcel at a duly advertised public sale with open bidding which is provided by law, including but not limited to execution sale, foreclosure sale, judicial sale or tax sale.

ARTICLE XII

AMENDMENTS TO DECLARATION

The rights of Developer in Article II as to Phasing and Article V and any other article in this Declaration affecting the rights of the Developer shall not be subject to amendment without the consent of the Developer, and shall not be subject to the provisions of this Article XII. Article XIII entitled "Termination" may not be amended without the consent of all owners and mortgagees of record. Except as provided in Article II, Paragraph 2, no amendment shall change any Unit or its appurtenant share in the Common Elements unless the Owner and all mortgagees of record shall join in the execution of the amendment. No amendment may change Article VIII entitled "Insurance" nor Article VII, Paragraph 4, entitled "Reconstruction or Repair After Casualty", unless all mortgagees of record shall join in the execution of the amendment.

Subject to the above provisions, this Declaration of Condominium may be amended as follows:

1. Until the election of a majority of the Board of Directors by the Owners, this Declaration may be amended by vote

of all of the Board of Directors provided that the amendment does not increase the number of Units nor alter the boundaries of the Common Elements. In that event, the amendment must be approved by two-thirds (2/3) of the votes of the Owners regardless of whether the Owners have elected a majority of the Board of Directors.

2. After the election of a majority of the Board of Directors by the Owners, this Declaration may be amended at a meeting of the members of the Association. Amendments may be proposed by the Board of Directors or by individual members of the Association. Proposals shall be submitted in writing to the President of the Association who, upon receipt, shall call a meeting of the Association to consider the proposed amendment. The meeting shall be held within thirty (30) days after receipt by the President of the proposed amendment. Notice of the meeting specifying the proposed amendment shall be furnished in accordance with the Bylaws of the Association. At the meeting, the proposed amendment shall be adopted if approved by not less than seventy-five percent (75%) of the votes of the entire membership of the association.

After adoption of any amendment pursuant to this Article, the officers of the Association shall execute and record in the public records of the County in which the Property is located, a certificate certifying that the amendment was duly adopted. The amendment shall be effective when the certificate and a copy of the amendment are duly recorded.

ARTICLE XIII

TERMINATION

The Condominium may be terminated in the following ways:

1. Destruction. In the event it is determined pursuant to Article VII, Paragraph 4a, that the Condominium buildings shall not be reconstructed, the Condominium will be thereby terminated without agreement of the Owners and mortgagees of record.

2. Agreement. The Condominium may be terminated by the approval in writing of all of the Owners and mortgagees of record.

3. Termination by Purchase of Dissenting Owner's Units. If members holding a majority of votes in the Association desire termination, they may make a written request to the President of the Association for a meeting of the members to consider termination. Notice of the meeting shall be furnished as provided in the Bylaws. If the termination is approved at the meeting by a vote of not less than seventy-five percent (75%) of the votes of the Owners, and if the consent of all mortgagees on record is obtained in writing not later than sixty (60) days from the date of the meeting, then the approving Owners shall have an option to buy all (but not less than all) of the Condominium Parcels of the non-approving Owners for the period ending on the sixtieth (60th) day from the date of the meeting. Approval of termination by an Owner at such a meeting shall be irrevocable until the expiration of the option, and if the option is exercised, the approval shall be irrevocable.

The above option shall be exercised by delivery of the following instruments in person or by registered mail to each Owner of the Condominium Parcels to be purchased.

(a) A certificate executed by the President and Secretary of the Association certifying that the option to purchase has been exercised as to all Condominium Parcels owned by non-approving Owners. The certificate shall state the names of the Owners exercising the option, the Parcels owned by them and the Parcels being purchased by each of them.

(b) An agreement to purchase upon the terms herein stated, the Condominium Parcel of the Owner receiving the notice, which agreement shall be signed by the purchasing Owner.

The price for each Condominium Parcel purchased pursuant to this Article shall be its fair market value determined by agreement between the seller and purchaser within thirty (30) days from the delivery or mailing of the items specified above. In the absence of agreement as to price, it shall be determined by arbitration in accordance with Article XIV below, and the then

existing rules of the American Arbitration Association, except that the arbitrators shall be two appraisers appointed by the American Arbitration Association. If the appraisers cannot reach agreement upon the market value of the Condominium Parcel, then the market value shall be the average of the values reached by the two appraisers. All judgement of specific performance of the purchased based upon the determination of the arbitrators may be entered in any court of competent jurisdiction. The expense of the arbitration shall be paid equally by the purchaser and seller. The sale price shall be paid in cash, or upon terms approved by the seller and the Association and the sale shall be closed within twenty (20) days following the determination of the sale price. The closing of the purchase of all the Condominium Parcels subject to the above option shall effect a termination of the Condominium without further act except the filing of a certificate hereafter required.

4. Certificate. The termination of the Condominium in any of the foregoing ways shall be evidenced by a certificate of the Association executed by the President and Secretary certifying as to facts effecting the termination, which certificate shall become effective upon being recorded in the public records.

5. Shares of Owners After Termination. After termination of the Condominium, the Owners shall own the Condominium Property and all assets of the Association, including the right to insure proceeds, if any, as tenants in common in undivided shares, and their respective mortgagees and lienors shall have mortgages and

liens upon the respective undivided shares of the Owners. Such undivided shares of the Owners shall be the same as the undivided shares in Common Elements appurtenant to the Owners' Units prior to the termination. Following termination, any Owner may request distribution to him of his proportionate share in all liquid assets of the Association, but Owners shall not have the right to partition the Property and by their acceptance of this Declaration shall be deemed to have waived such right to partition.

ARTICLE XIV

ARBITRATION

1. When Used. The process of arbitration as herein set forth shall be used to determine the fair market value of a Unit for purposes of sale pursuant to Article XIII and when any controversy arises as to the construction of or compliance with any provision of this Declaration.

2. Procedure. Any party to a controversy subject to arbitration hereunder may institute proceedings upon written notice delivered to the other parties in person or by certified mail, which shall reasonably identify the subject of controversy. Within fifteen (15) days from receipt of such notice, each party shall name and appoint one arbitrator. If any party fails to appoint an arbitrator within the above period, the party having made his appointment shall appoint a second arbitrator. The two appointed arbitrators shall then appoint a third. Upon their failure to appoint a third arbitrator within a reasonable time,

application may be made by either party to the Circuit Court of the county in which the Property is located for such appointment.

The arbitrators shall select the time and place for hearing on the controversy, and shall notify the parties of the time and place by written notice delivered in person or by registered mail at least five (5) days prior to the hearing. The hearing shall be conducted by all of the arbitrators, but a majority may determine any questions and render a final decision and award. The arbitration shall be conducted according to the rules of the American Arbitration Association except where they specifically override or contradict the laws of the State of Florida.

The decision and award of the arbitrators shall be in writing signed by all of the arbitrators and delivered to the parties in person or by certified mail within a reasonable time after the final hearing day. Such decision shall be binding on all parties and shall be specifically enforceable in any court of competent jurisdiction. The fees of the arbitrators and the costs and expenses incurred in the arbitration shall be paid equally by the parties. Each party shall be responsible for paying the fee of his own counsel.

ARTICLE XVI

SEVERABILITY

The invalidity in whole or in part of any covenant or restriction, or any article, paragraph, section, subsection, sentence, clause, phrase or word, or other provision of this Declaration, the Articles of Incorporation, Bylaws or Regulation

of the Association, or any other document governing the Condominium shall not affect the validity of the remaining portions thereof.

IN WITNESS WHEREOF, the Developer has executed this Declaration this 20th day of October, 1982.



OCEAN VILLAS CONDOMINIUM INVESTORS, LTD.

[Signature]
General Partner, Ocean Villas, Inc.,
President

STATE OF FLORIDA
COUNTY OF DUVAL

Before me personally appeared R.V. HARVEY, JR. the General Partner of Ocean Villas Condominium Investors, Ltd., a Florida limited partnership to me well known to be the individual and officer described in and who executed the foregoing instrument and acknowledged the execution thereof to be his own free act and deed as such officer thereunto duly authorized; and that the official seal of said corporation is duly affixed thereto, and the said instrument is the act and deed of said corporation.

IN WITNESS WHEREOF, I have hereunto set my hand and seal this 20th day of October, 1982, at Opakosville in the State and County aforesaid.

[Signature]
Notary Public
State of Florida at Large
My Commission Expires:
NOTARY PUBLIC, STATE OF FLORIDA
My commission expires Jan. 7, 1985

Description for access road to Phase I, Ocean Villas, St. Augustine Beach, Florida

DESCRIPTION:

A PARCEL OF LAND IN THE SOUTH 220 FEET OF THE NORTH 1,320 FEET OF GOVERNMENT LOT 3, SECTION 3, TOWNSHIP 8 SOUTH, RANGE 30 EAST, ST. JOHNS COUNTY, FLORIDA AND IN THE NORTH 200 FEET OF GOVERNMENT LOT 5 OF SAID SECTION 3; SAID PARCEL OF LAND BEING MORE FULLY DESCRIBED AS FOLLOWS:

COMMENCING AT THE INTERSECTION OF THE EAST RIGHT OF WAY LINE OF STATE ROAD NO. A-1-A (SAID RIGHT OF WAY LINE BEING 50 FEET EAST OF THE CENTER LINE OF SAID ROAD) WITH THE NORTH LINE OF SAID SOUTH 220 FEET OF THE NORTH 1,320 FEET OF GOVERNMENT LOT 3; THENCE NORTH 89 DEGREES 38 MINUTES 10 SECONDS EAST, ON SAID NORTH LINE OF THE SOUTH 220 FEET OF THE NORTH 1,320 FEET OF GOVERNMENT LOT 3, A DISTANCE OF 303.83 FEET; THENCE SOUTH 00 DEGREES 21 MINUTES 50 SECONDS EAST 25 FEET TO THE POINT OF BEGINNING OF THE HEREIN DESCRIBED PARCEL OF LAND; THENCE CONTINUING SOUTH 00 DEGREES 21 MINUTES 50 SECONDS EAST 22 FEET; THENCE SOUTH 89 DEGREES 38 MINUTES 10 SECONDS WEST 250.79 FEET TO THE POINT OF A CURVE TO THE LEFT WITH RADIUS OF 10 FEET; THENCE, ON SAID CURVE TO THE LEFT THROUGH A CENTRAL ANGLE OF 73 DEGREES 00 MINUTES, AN ARC DISTANCE OF 12.74 FEET TO THE POINT OF TANGENCY OF SAID CURVE; THENCE SOUTH 16 DEGREES 38 MINUTES 10 SECONDS WEST 131.35 FEET TO A POINT; THENCE, ON A CURVE EASTERLY, SOUTHERLY AND SOUTHWESTERLY ON A CURVE WITH RADIUS OF 30.5 FEET (BEARING FROM SAID LAST NAMED POINT TO THE CENTER OF SAID CURVE BEING SOUTH 00 DEGREES 16 MINUTES 24 SECONDS WEST), THROUGH A CENTRAL ANGLE OF 179 DEGREES 21 MINUTES 46 SECONDS, AN ARC DISTANCE OF 95.48 FEET TO THE END OF SAID CURVE; THENCE SOUTH 89 DEGREES 38 MINUTES 10 SECONDS WEST, TANGENT TO SAID CURVE, 12.93 FEET; THENCE SOUTH 16 DEGREES 38 MINUTES 10 SECONDS WEST 52.08 FEET TO THE POINT OF A CURVE TO THE LEFT WITH RADIUS OF 108 FEET; THENCE, ON SAID CURVE TO THE LEFT,

(CONT. ON SHEET 2 OF 2)

THROUGH A CENTRAL ANGLE OF 17 DEGREES 00 MINUTES, AN ARC DISTANCE OF 32.04 FEET TO THE POINT OF TANGENCY OF SAID CURVE; THENCE SOUTH 00 DEGREES 21 MINUTES 50 SECONDS EAST 41.32 FEET TO THE POINT OF A CURVE TO THE LEFT WITH RADIUS OF 10 FEET; THENCE, ON SAID CURVE TO THE LEFT THROUGH A CENTRAL ANGLE OF 90 DEGREES 00 MINUTES, AN ARC DISTANCE OF 15.71 FEET TO THE POINT OF TANGENCY OF SAID CURVE; THENCE NORTH 89 DEGREES 38 MINUTES 10 SECONDS EAST 306.97 FEET; THENCE SOUTH 00 DEGREES 21 MINUTES 50 SECONDS EAST 22 FEET; THENCE SOUTH 89 DEGREES 38 MINUTES 10 SECONDS WEST, 25 FEET NORTH OF AND PARALLEL WITH THE SOUTH LINE OF SAID NORTH 200 FEET OF GOVERNMENT LOT 5, A DISTANCE OF 306.97 FEET TO THE POINT OF A CURVE TO THE RIGHT WITH RADIUS OF 32 FEET; THENCE, ON SAID CURVE TO THE RIGHT THROUGH A CENTRAL ANGLE OF 90 DEGREES 00 MINUTES, AN ARC DISTANCE OF 50.27 FEET TO THE POINT OF TANGENCY OF SAID CURVE; THENCE NORTH 00 DEGREES 21 MINUTES 50 SECONDS WEST 41.32 FEET TO THE POINT OF A CURVE TO THE RIGHT WITH RADIUS OF 130 FEET; THENCE, ON SAID CURVE TO THE RIGHT THROUGH A CENTRAL ANGLE OF 17 DEGREES 00 MINUTES, AN ARC DISTANCE OF 38.57 FEET TO THE POINT OF TANGENCY OF SAID CURVE; THENCE NORTH 16 DEGREES 38 MINUTES 10 SECONDS EAST 31.13 FEET TO THE POINT OF A CURVE TO THE LEFT WITH RADIUS OF 10 FEET; THENCE, ON SAID CURVE TO THE LEFT THROUGH A CENTRAL ANGLE OF 107 DEGREES 00 MINUTES, AN ARC DISTANCE OF 18.68 FEET TO THE POINT OF TANGENCY OF SAID CURVE; THENCE SOUTH 89 DEGREES 38 MINUTES 10 SECONDS WEST 21.00 FEET; THENCE NORTH 17 DEGREES 04 MINUTES EAST, ON SAID EAST RIGHT OF WAY LINE OF STATE ROAD, 8.65 FEET TO THE POINT OF A CURVE TO THE LEFT WITH RADIUS OF 3,085.15 FEET; THENCE, ON SAID CURVE TO THE LEFT AND ON SAID RIGHT OF WAY LINE THROUGH A CENTRAL ANGLE OF 1 DEGREE 01 MINUTE 25 SECONDS, AN ARC DISTANCE OF 55.12 FEET; THENCE NORTH 89 DEGREES 38 MINUTES 10 SECONDS EAST 21.74 FEET TO THE POINT OF A CURVE TO THE LEFT WITH RADIUS OF 10 FEET; THENCE, ON SAID CURVE TO THE LEFT THROUGH A CENTRAL ANGLE OF 73 DEGREES 00 MINUTES, AN ARC DISTANCE OF 12.74 FEET TO THE POINT OF TANGENCY OF SAID CURVE; THENCE NORTH 16 DEGREES 38 MINUTES 10 SECONDS EAST 130.68 FEET TO THE POINT OF A CURVE TO THE RIGHT WITH RADIUS OF 32 FEET; THENCE, ON SAID CURVE TO THE RIGHT THROUGH A CENTRAL ANGLE OF 73 DEGREES 00 MINUTES, AN ARC DISTANCE OF 40.77 FEET TO THE POINT OF TANGENCY OF SAID CURVE; THENCE NORTH 89 DEGREES 38 MINUTES 10 SECONDS EAST 250.79 FEET TO THE POINT OF BEGINNING.

Prepared by: Loren N. Jones, P.E./L.S.
St. Augustine, Florida

Description Phase I, Ocean Villas, St. Augustine Beach, Florida

DESCRIPTION:

A PARCEL OF LAND IN THE SOUTH 220 FEET OF THE NORTH 1,320 FEET OF GOVERNMENT LOT 3, SECTION 3, TOWNSHIP 8 SOUTH, RANGE 30 EAST, ST. JOHNS COUNTY, FLORIDA AND IN THE NORTH 200 FEET OF GOVERNMENT LOT 5 OF SAID SECTION 3; SAID PARCEL OF LAND BEING MORE FULLY DESCRIBED AS FOLLOWS:

COMMENCING AT THE INTERSECTION OF THE EAST RIGHT OF WAY LINE OF STATE ROAD NO. A-1-A (SAID RIGHT OF WAY LINE BEING 50 FEET EAST OF THE CENTER LINE OF SAID ROAD) WITH THE NORTH LINE OF SAID SOUTH 220 FEET OF THE NORTH 1,320 FEET OF GOVERNMENT LOT 3; THENCE NORTH 89 DEGREES 38 MINUTES 10 SECONDS EAST, ON SAID NORTH LINE OF THE SOUTH 220 FEET OF THE NORTH 1,320 FEET OF GOVERNMENT LOT 3, A DISTANCE OF 303.83 FEET TO THE POINT OF BEGINNING AT THE NORTHWEST CORNER OF THE HEREIN DESCRIBED PARCEL OF LAND; THENCE CONTINUING NORTH 89 DEGREES 38 MINUTES 10 SECONDS EAST, ON SAID NORTH LINE OF THE SOUTH 220 FEET OF THE NORTH 1,320 FEET OF GOVERNMENT LOT 3, A DISTANCE OF 605 FEET MORE OR LESS TO THE APPROXIMATE MEAN HIGH WATER LINE OF THE ATLANTIC OCEAN; THENCE SOUTHERLY, ON SAID MEAN HIGH WATER LINE, 421 FEET MORE OR LESS TO THE SOUTH LINE OF SAID NORTH 200 FEET OF GOVERNMENT LOT 5; THENCE SOUTH 89 DEGREES 38 MINUTES 10 SECONDS WEST, ON SAID SOUTH LINE OF THE NORTH 200 FEET OF GOVERNMENT LOT 5, A DISTANCE OF 655 FEET MORE OR LESS TO A POINT WHICH IS NORTH 89 DEGREES 38 MINUTES 10 SECONDS EAST 410.97 FEET FROM SAID EAST RIGHT OF WAY LINE OF STATE ROAD NO. A-1-A; THENCE NORTH 00 DEGREES 21 MINUTES 50 SECONDS WEST 65 FEET; THENCE NORTH 89 DEGREES 38 MINUTES 10 SECONDS EAST 20 FEET; THENCE NORTH 31 DEGREES 08 MINUTES 10 SECONDS EAST 170.28 FEET; THENCE NORTH 31 DEGREES 51 MINUTES 50 SECONDS WEST 170.29 FEET; THENCE SOUTH 89 DEGREES 38 MINUTES 10 SECONDS WEST 5 FEET; THENCE NORTH 00 DEGREES 21 MINUTES 50 SECONDS WEST 65 FEET TO THE POINT OF BEGINNING.

(CONT. ON SHEET 2 OF 2)

TOGETHER WITH ALL ALLUVION, AVULSION, RELICTION AND ACCRETIONS WHICH NOW, HERETOFORE, OR HEREAFTER MAY BELONG TO ANY OF THE ABOVE DESCRIBED LANDS, AND ALSO ALL RIPARIAN AND LITTORAL RIGHT, NOW, HERETOFORE, AND HEREAFTER APPERTAINING TO SAID LANDS WHICH LIE EAST OF AND ADJOINING THE ABOVE DESCRIBED LANDS.

Prepared by: Loren N. Jones, P.E./L.S.
St. Augustine, Florida

Description Phase I, Ocean Villas, St. Augustine Beach, Florida

DESCRIPTION:

A PARCEL OF LAND IN THE SOUTH 220 FEET OF THE NORTH 1,320 FEET OF GOVERNMENT LOT 3, SECTION 3, TOWNSHIP 8 SOUTH, RANGE 30 EAST, ST. JOHNS COUNTY, FLORIDA AND IN THE NORTH 200 FEET OF GOVERNMENT LOT 5 OF SAID SECTION 3; SAID PARCEL OF LAND BEING MORE FULLY DESCRIBED AS FOLLOWS:

COMMENCING AT THE INTERSECTION OF THE EAST RIGHT OF WAY LINE OF STATE ROAD NO. A-1-A (SAID RIGHT OF WAY LINE BEING 50 FEET EAST OF THE CENTER LINE OF SAID ROAD) WITH THE NORTH LINE OF SAID SOUTH 220 FEET OF THE NORTH 1,320 FEET OF GOVERNMENT LOT 3; THENCE NORTH 89 DEGREES 38 MINUTES 10 SECONDS EAST, ON SAID NORTH LINE OF THE SOUTH 220 FEET OF THE NORTH 1,320 FEET OF GOVERNMENT LOT 3, A DISTANCE OF 303.83 FEET TO THE POINT OF BEGINNING AT THE NORTHWEST CORNER OF THE HEREIN DESCRIBED PARCEL OF LAND; THENCE CONTINUING NORTH 89 DEGREES 38 MINUTES 10 SECONDS EAST, ON SAID NORTH LINE OF THE SOUTH 220 FEET OF THE NORTH 1,320 FEET OF GOVERNMENT LOT 3, A DISTANCE OF 605 FEET MORE OR LESS TO THE APPROXIMATE MEAN HIGH WATER LINE OF THE ATLANTIC OCEAN; THENCE SOUTHERLY, ON SAID MEAN HIGH WATER LINE, 421 FEET MORE OR LESS TO THE SOUTH LINE OF SAID NORTH 200 FEET OF GOVERNMENT LOT 5; THENCE SOUTH 89 DEGREES 38 MINUTES 10 SECONDS WEST, ON SAID SOUTH LINE OF THE NORTH 200 FEET OF GOVERNMENT LOT 5, A DISTANCE OF 655 FEET MORE OR LESS TO A POINT WHICH IS NORTH 89 DEGREES 38 MINUTES 10 SECONDS EAST 410.97 FEET FROM SAID EAST RIGHT OF WAY LINE OF STATE ROAD NO. A-1-A; THENCE NORTH 00 DEGREES 21 MINUTES 50 SECONDS WEST 65 FEET; THENCE NORTH 89 DEGREES 38 MINUTES 10 SECONDS EAST 20 FEET; THENCE NORTH 31 DEGREES 08 MINUTES 10 SECONDS EAST 170.28 FEET; THENCE NORTH 31 DEGREES 51 MINUTES 50 SECONDS WEST 170.29 FEET; THENCE SOUTH 89 DEGREES 38 MINUTES 10 SECONDS WEST 5 FEET; THENCE NORTH 00 DEGREES 21 MINUTES 50 SECONDS WEST 65 FEET TO THE POINT OF BEGINNING.

(CONT. ON SHEET 2 OF 2)

TOGETHER WITH ALL ALLUVION, AVULSION, RELICTION AND ACCRETIONS WHICH NOW, HERETOFORE, OR HEREAFTER MAY BELONG TO ANY OF THE ABOVE DESCRIBED LANDS, AND ALSO ALL RIPARIAN AND LITTORAL RIGHT, NOW, HERETOFORE, AND HEREAFTER APPERTAINING TO SAID LANDS WHICH LIE EAST OF AND ADJOINING THE ABOVE DESCRIBED LANDS.

Prepared by: Loren N. Jones, P.E./L.S.
St. Augustine, Florida

Description for access road to Phase I, Ocean Villas, St. Augustine
Beach, Florida

DESCRIPTION:

A PARCEL OF LAND IN THE SOUTH 220 FEET OF THE NORTH 1,320 FEET OF GOVERNMENT LOT 3, SECTION 3, TOWNSHIP 8 SOUTH, RANGE 30 EAST, ST. JOHNS COUNTY, FLORIDA AND IN THE NORTH 200 FEET OF GOVERNMENT LOT 5 OF SAID SECTION 3; SAID PARCEL OF LAND BEING MORE FULLY DESCRIBED AS FOLLOWS:

COMMENCING AT THE INTERSECTION OF THE EAST RIGHT OF WAY LINE OF STATE ROAD NO. A-1-A (SAID RIGHT OF WAY LINE BEING 50 FEET EAST OF THE CENTER LINE OF SAID ROAD) WITH THE NORTH LINE OF SAID SOUTH 220 FEET OF THE NORTH 1,320 FEET OF GOVERNMENT LOT 3; THENCE NORTH 89 DEGREES 38 MINUTES 10 SECONDS EAST, ON SAID NORTH LINE OF THE SOUTH 220 FEET OF THE NORTH 1,320 FEET OF GOVERNMENT LOT 3, A DISTANCE OF 303.83 FEET; THENCE SOUTH 00 DEGREES 21 MINUTES 50 SECONDS EAST 25 FEET TO THE POINT OF BEGINNING OF THE HEREIN DESCRIBED PARCEL OF LAND; THENCE CONTINUING SOUTH 00 DEGREES 21 MINUTES 50 SECONDS EAST 22 FEET; THENCE SOUTH 89 DEGREES 38 MINUTES 10 SECONDS WEST 250.79 FEET TO THE POINT OF A CURVE TO THE LEFT WITH RADIUS OF 10 FEET; THENCE, ON SAID CURVE TO THE LEFT THROUGH A CENTRAL ANGLE OF 73 DEGREES 00 MINUTES, AN ARC DISTANCE OF 12.74 FEET TO THE POINT OF TANGENCY OF SAID CURVE; THENCE SOUTH 16 DEGREES 38 MINUTES 10 SECONDS WEST 131.35 FEET TO A POINT; THENCE, ON A CURVE EASTERLY, SOUTHERLY AND SOUTHWESTERLY ON A CURVE WITH RADIUS OF 30.5 FEET (BEARING FROM SAID LAST NAMED POINT TO THE CENTER OF SAID CURVE BEING SOUTH 00 DEGREES 16 MINUTES 24 SECONDS WEST), THROUGH A CENTRAL ANGLE OF 179 DEGREES 21 MINUTES 46 SECONDS, AN ARC DISTANCE OF 95.48 FEET TO THE END OF SAID CURVE; THENCE SOUTH 89 DEGREES 38 MINUTES 10 SECONDS WEST, TANGENT TO SAID CURVE, 12.93 FEET; THENCE SOUTH 16 DEGREES 38 MINUTES 10 SECONDS WEST 52.08 FEET TO THE POINT OF A CURVE TO THE LEFT WITH RADIUS OF 108 FEET; THENCE, ON SAID CURVE TO THE LEFT,

(CONT. ON SHEET 2 OF 2)

THROUGH A CENTRAL ANGLE OF 17 DEGREES 00 MINUTES, AN ARC DISTANCE OF 32.04 FEET TO THE POINT OF TANGENCY OF SAID CURVE; THENCE SOUTH 00 DEGREES 21 MINUTES 50 SECONDS EAST 41.32 FEET TO THE POINT OF A CURVE TO THE LEFT WITH RADIUS OF 10 FEET; THENCE, ON SAID CURVE TO THE LEFT THROUGH A CENTRAL ANGLE OF 90 DEGREES 00 MINUTES, AN ARC DISTANCE OF 15.71 FEET TO THE POINT OF TANGENCY OF SAID CURVE; THENCE NORTH 89 DEGREES 38 MINUTES 10 SECONDS EAST 306.97 FEET; THENCE SOUTH 00 DEGREES 21 MINUTES 50 SECONDS EAST 22 FEET; THENCE SOUTH 89 DEGREES 38 MINUTES 10 SECONDS WEST, 25 FEET NORTH OF AND PARALLEL WITH THE SOUTH LINE OF SAID NORTH 200 FEET OF GOVERNMENT LOT 5, A DISTANCE OF 306.97 FEET TO THE POINT OF A CURVE TO THE RIGHT WITH RADIUS OF 32 FEET; THENCE, ON SAID CURVE TO THE RIGHT THROUGH A CENTRAL ANGLE OF 90 DEGREES 00 MINUTES, AN ARC DISTANCE OF 50.27 FEET TO THE POINT OF TANGENCY OF SAID CURVE; THENCE NORTH 00 DEGREES 21 MINUTES 50 SECONDS WEST 41.32 FEET TO THE POINT OF A CURVE TO THE RIGHT WITH RADIUS OF 130 FEET; THENCE, ON SAID CURVE TO THE RIGHT THROUGH A CENTRAL ANGLE OF 17 DEGREES 00 MINUTES, AN ARC DISTANCE OF 38.57 FEET TO THE POINT OF TANGENCY OF SAID CURVE; THENCE NORTH 16 DEGREES 38 MINUTES 10 SECONDS EAST 31.13 FEET TO THE POINT OF A CURVE TO THE LEFT WITH RADIUS OF 10 FEET; THENCE, ON SAID CURVE TO THE LEFT THROUGH A CENTRAL ANGLE OF 107 DEGREES 00 MINUTES, AN ARC DISTANCE OF 18.68 FEET TO THE POINT OF TANGENCY OF SAID CURVE; THENCE SOUTH 89 DEGREES 38 MINUTES 10 SECONDS WEST 21.00 FEET; THENCE NORTH 17 DEGREES 04 MINUTES EAST, ON SAID EAST RIGHT OF WAY LINE OF STATE ROAD, 8.65 FEET TO THE POINT OF A CURVE TO THE LEFT WITH RADIUS OF 3,085.15 FEET; THENCE, ON SAID CURVE TO THE LEFT AND ON SAID RIGHT OF WAY LINE THROUGH A CENTRAL ANGLE OF 1 DEGREE 01 MINUTE 25 SECONDS, AN ARC DISTANCE OF 55.12 FEET; THENCE NORTH 89 DEGREES 38 MINUTES 10 SECONDS EAST 21.74 FEET TO THE POINT OF A CURVE TO THE LEFT WITH RADIUS OF 10 FEET; THENCE, ON SAID CURVE TO THE LEFT THROUGH A CENTRAL ANGLE OF 73 DEGREES 00 MINUTES, AN ARC DISTANCE OF 12.74 FEET TO THE POINT OF TANGENCY OF SAID CURVE; THENCE NORTH 16 DEGREES 38 MINUTES 10 SECONDS EAST 130.68 FEET TO THE POINT OF A CURVE TO THE RIGHT WITH RADIUS OF 32 FEET; THENCE, ON SAID CURVE TO THE RIGHT THROUGH A CENTRAL ANGLE OF 73 DEGREES 00 MINUTES, AN ARC DISTANCE OF 40.77 FEET TO THE POINT OF TANGENCY OF SAID CURVE; THENCE NORTH 89 DEGREES 38 MINUTES 10 SECONDS EAST 250.79 FEET TO THE POINT OF BEGINNING.

Prepared by: Loren N. Jones, P.E./L.S.
St. Augustine, Florida

PHASE II

OFF REC 565 PAGE 582

The South 220 feet of the North 1320 feet of Government Lot 4, Section 3, Township 8 South, Range 30 East of State Road No. A-1-A, in St. Johns County, Florida, as described in deed recorded in Deed Book 194, Page 259, public records of said county, together with all rights as described in deed recorded in Official Records Book 46, Page 548, said public records. Together with all alluvion, avulsion, reliction and accretions which now, heretofore, or hereafter may belong to any of the above described lands, and also all riparian and littoral right, now, heretofore, and hereafter appertaining to said lands which lie east of and adjoining the above described lands, and

The North two hundred (200) feet of Government Lot 5 of Section 3, Township 8 South of range 30 East, which lies East of a line running parallel with and 50 feet East of the Center Line of State Road No. 140 as now located. Together with all alluvion, avulsion, reliction and accretions, which now, heretofore, or hereafter may belong to the above described lands, and also all riparian and littoral rights now, heretofore and hereafter to said land, together with all right, title and interest of the Grantors in and to any lands which lie east of and adjoin the above described land. The above mentioned State Road No. 140 being now known as State Road A-1-A less and except the property described on the attachment hereto.

OF

OCEAN VILLAS AT ST. AUGUSTINE BEACH
CONDOMINIUM ASSOCIATION, INC.

(A corporation not for profit)

We, the undersigned, being desirous of forming a corporation not for profit under the provisions of Chapter 617, Florida Statutes, do hereby agree to the following Articles of Incorporation:

ARTICLE I - Name

The name of this corporation is OCEAN VILLAS AT ST. AUGUSTINE BEACH CONDOMINIUM ASSOCIATION, INC. (herein referred to as the "Association").

ARTICLE II - Purposes

The purposes and objectives of the Association shall be to administer the operation and management of OCEAN VILLAS AT ST. AUGUSTINE BEACH CONDOMINIUM (the "Condominium"), established pursuant to Chapter 718, Florida Statutes (the "Condominium Act"), on the real property in St. Johns County, Florida and described in the Declaration of Condominium of OCEAN VILLAS AT ST. AUGUSTINE BEACH CONDOMINIUM, (the "Declaration") and to undertake and perform all acts and duties incident to the administration, operation and management of the Condominium, in accordance with the terms, provisions, conditions and authorizations contained herein and in the Declaration; and to own, operate, lease, sell, manage and otherwise deal with such real and personal property as may be necessary or convenient for the administration of

EXHIBIT III

the Condominium Association shall be conducted as a non-profit organization for the benefit of its members.

ARTICLE III - Powers

OFF REC 565 PAGE 584

The Association shall have all of the powers and privileges granted to a corporation not for profit under the laws of Florida pursuant to which this Association is chartered, all of the powers and duties set forth in the Condominium Act and the Declaration of Condominium, and all other powers reasonably necessary to effectuate the purposes of the Association set out herein, together with, but not limited to, the following powers:

1. To make and establish rules and regulations governing the use and activities of the Condominium.
2. To levy and collect assessments against members of the Association in accordance with the terms of the Declaration of Condominium and such By Laws of this Association as may be adopted, including the right to use the proceeds of assessments to operate and manage the Condominium and for other purposes set forth in the Declaration of Condominium.
3. To make contracts and incur liabilities, borrow or lend money at such rates of interest as the Association may determine, issue its notes, bonds and other obligations, and secure any of its obligations by mortgage and pledge of all or any of its property, franchises or income.

4. To purchase, lease, take by gift, devise or bequest, or otherwise acquire, own, hold, improve, use or otherwise deal in and with real or personal property, or any interest therein.

5. To maintain, repair, replace, operate and manage the Condominium, and the real and personal property comprising it including the right to reconstruct improvements and replace personal property after damage by casualty and to make further improvement of the condominium property and to purchase replacements and additional property and improvements.

6. To enter into contracts for management, operation, insurance coverage and maintenance of the Condominium Property.

7. To contract for the management and maintenance of the condominium property and to authorize a management agent to assist the association in carrying out its powers and duties by performing such functions as the submission of proposals, collection of assessments, preparation of records, enforcement of rules and maintenance, repair and replacement of the common elements with funds as shall be made available by the association for such purposes. The association and its officers shall, however, retain at all times the powers and duties granted by the condominium documents and the Condominium Act, including but not limited to the making of assessments, promulgation of rules and

execution of contracts on behalf of the association.

8. To employ personnel to perform the services required for the operation of the Condominium.

9. To enforce the provisions of the Declaration of Condominium, these Articles of Incorporation, the By Laws of the Association which may be hereafter adopted, and the rules and regulations governing the use of the Condominium as may be hereafter established.

10. To exercise, undertake and accomplish all of the rights, duties and obligations which may be granted to or imposed upon the Association pursuant to the Declaration of Condominium.

ARTICLE IV

Qualification of Members

The qualification of the members, of their admission to membership, termination of membership and voting by members shall be as follows:

1. Members of the Association shall consist of all of the owners of condominium dwelling units in the Condominium, and no other persons or entities shall be entitled to membership.

2. A person shall become a member by the acquisition of a fee ownership interest in a dwelling unit in the

Condominium, whether by conveyance, devise, judicial decree or otherwise. The membership of any person shall be automatically terminated upon his being divested of his title to or interest in the dwelling unit. Transfer of membership shall be recognized by the Association upon its being provided with a certified copy of the recorded deed conveying title to a dwelling unit to the new members. If a corporation is the recorded owner of a dwelling unit, the corporation shall designate one officer or director as the member.

3. Except as an appurtenance to his dwelling unit, no member can assign, hypothecate or transfer in any manner, his membership in the Association or his interest in the funds and assets of the Association. The funds and assets of the Association shall belong solely to the Association subject to the limitation that the same be expended, held or used for the benefit of the membership and for the purposes authorized herein, in the Declaration of Condominium, and in the By Laws which may be hereafter adopted.

4. On all matters on which the membership shall be entitled to vote, there shall be only one vote for each condominium parcel in the Condominium. A vote may be exercised or cast by the owner or owners of each condominium parcel in such manner as may be provided in the By Laws hereafter adopted by the Association.

ARTICLE V

Term of Existence

The Association is to exist perpetually.

ARTICLE VI

Officers

1. The officers of the Association shall be a President, a Vice President, a Secretary, a Treasurer and such other officers, including a General Manager, as may be deemed desirable or necessary by the Board of Directors.

2. The persons who are to serve as officers of the Association until their successors are chosen are:

<u>Officer</u>	<u>Name</u>
President & Treasurer	Edwin K. Martin
Vice President & Secretary	Nancee Sue McGinnis

3. The officers shall be elected by the Board of Directors at their annual meeting as provided in the By-Laws. Any vacancies in any office shall be filled by the Board of Directors at any meeting duly held.

ARTICLE VII - Board of Directors

DEF 565 PAGE 589
REC

1. The business affairs of this Association shall be managed by the Board of Directors. This Association shall have five (5) directors initially. The number of directors may be increased or decreased from time to time as provided by the By-Laws but shall never be less than five (5) nor greater than nine (9).

2. Each director shall be a member of the Association; provided, however, that until the first meeting of the membership of the Association as provided in the By-Laws, directors need not be members of the Association.

3. Subject to the Declaration of Condominium, the Board of Directors shall be elected by the members of the Association from among the membership at the annual meeting as provided in the By-Laws. Vacancies on the Board may be filled by the remaining directors at any duly called meeting.

4. The names and addresses of the persons who are to serve as directors until their successors are chosen are:

Edwin K. Martin	No. 2 D Street St. Augustine Beach, FL 32084
Nancee Sue McGinnis	No. 2 D Street St. Augustine Beach, FL 32084
Jeffrey L. Meldon	35 North Main Street, Suite 25 Gainesville, FL 32601
Harry Meldon	24260 Shaker Boulevard Shaker Heights, Ohio 44122
Charles G. Brackins	35 North Main Street, Suite 25 Gainesville, FL

ARTICLE VIII - By Laws

OFF REC 565 PAGE 590

1. The Board of Directors of this Association may provide such By Laws for the conduct of its business and the carrying out of its purposes as it may deem necessary from time to time.

2. The By Laws may be amended, altered or rescinded upon the proposal of a majority of the Board of Directors and approval in person or in writing of the members of the Association holding a majority of votes present at a regular or special meeting of the members, the notice of which shall state that such proposal is to be voted upon at the meeting.

ARTICLE IX - Amendments

These Articles of Incorporation may be amended as follows:

1. Amendments shall be proposed by the Board of Directors of the Association acting upon a vote of a majority of the directors.

2. Such proposed amendments shall become effective when approved by an affirmative vote of members owning at least 75% of the votes. The membership shall vote on the proposed amendments at any regular or specially called meeting for such purpose, the notice of which shall describe the amendment or amendments being proposed. Votes may be in person or by written proxy.

ARTICLE X - Location

The location of this Association shall be 1041 South Ala, St. Augustine Beach, Florida 32084, or at such other place or places as the Board of Directors may designate.

ARTICLE XI - Non Profit Status

1. No part of the net earnings of the Association shall inure to the benefit of any individual or member.
2. The Association shall not carry on propaganda, or otherwise act to influence legislation.

ARTICLE XII - Indemnity

Every director and every other officer of the Association shall be indemnified by the Association against all expenses and liabilities, including attorneys' fees, reasonably incurred by or imposed upon him in connection with any proceeding to which he may be a party, or in which he may become involved, by reason of his being or having been a director or officer of the Association, whether or not he is a director or officer at the time such expenses are incurred, except in such cases wherein the director or officer is adjudged by a court of competent jurisdiction to be guilty of willful misfeasance or malfeasance in the performance of his duties. The foregoing right of indemnification shall be in addition to and not exclusive of all other rights to which such director or officer may be entitled.

The names and addresses of the subscribers to these Articles are:

OFF REC 565 PAGE 592

Jeffrey L. Meldon	35 North Main Street Gainesville, Florida 32601
Edwin K. Martin	No. 2 D Street St. Augustine Beach, FL 32084
Nancee Sue McGinnis	No. 2 D Street St. Augustine Beach, FL 32084

IN WITNESS WHEREOF, we, the undersigned, subscribing incorporators, have hereunto set our hands and seals this 9th day of Oct., 1980, for the purpose of forming this corporation not for profit under the laws of the State of Florida.

[Signature] (Seal)

[Signature] (Seal)

[Signature] (Seal)

STATE OF FLORIDA)
COUNTY OF DUVAL)

BEFORE ME, a Notary Public duly authorized in the State and County aforesaid to take acknowledgements, personally appeared Jeffrey L. Meldon, Edwin K. Martin and Nancee Sue McGinnis, to me known to be the persons described as subscribers in and who executed the foregoing Articles of Incorporation, and they acknowledged before me that they executed and subscribed to these Articles of Incorporation.

WITNESS my hand and official seal this 9 day of Oct., 1980, in the State and County aforesaid.

[Signature]
Notary Public, State of Florida

My Commission Expires: Oct 22, 1983

BY LAWS OF
OCEAN VILLAS AT ST. AUGUSTINE BEACH
CONDOMINIUM ASSOCIATION, INC.

ARTICLE I

Members

(Unit Members)

Section 1. The members of Ocean Villas at St. Augustine Beach Condominium Association, Inc. (the "Association"), a corporation not for profit organized under the laws of the State of Florida, shall consist of the respective owners of condominium parcels ("Units") of Ocean Villas Condominium, located in St. Augustine Beach, Florida.

Section 2. The membership of each unit owner shall terminate when he ceases to be a unit owner, and upon the sale, transfer or other disposition of his ownership interest in a unit, membership in the Association shall automatically be transferred to the new unit owner succeeding to such ownership interest. The Association may issue certificates evidencing membership therein.

Section 3. Each unit shall be entitled to one vote at Association meetings, which shall be exercised by the unit owner. A majority of votes shall decide all questions at Association meetings, unless specified otherwise in these By Laws, the Articles of Incorporation, or the Declaration of Condominium of Ocean Villas Condominium (the "Declaration"). If a person owns more than one unit, he shall be entitled to one vote for each unit owned. In the event that a unit is owned by more than one

EXHIBIT IV

person, or by a corporation, trust or other entity, the person entitled to cast the vote for that unit shall be designated by a certificate filed with the Association and signed by all joint owners or an authorized agent of the corporation or other entity.

Section 4. A quorum at membership meetings shall consist of attendance in person or by proxy of members entitled to cast a majority of the votes of the entire membership. The joinder of a member in the action of a meeting by signing and concurring in the minutes thereof shall constitute the presence of such person for the purposes of determining a quorum.

Section 5. Votes may be cast in person or by proxy. Proxies shall be in writing, shall be valid only for the particular meeting designated thereon and must be filed with the secretary before the appointed time of the meeting.

ARTICLE II.

Meetings of Membership

Section 1. The meetings of the membership shall be held in accordance with the provisions of the Declaration and subject to that Declaration, in accordance with these By Laws. Persons owning an interest in a Unit other than the designated members may attend all membership meetings but shall not be entitled to notice thereof.

Section 2. The annual meeting of the membership of the Association shall be held at the offices of the Association or at such other place in the State of Florida, as shall be designated by the Board of Directors or the President of the

Association. The annual meeting shall be held in March of each year, unless otherwise determined by the Board of Directors.

Section 3. Unless specifically provided otherwise herein, special meetings of the membership shall be held when directed by the President of the Board of Directors or when requested in writing by members holding a majority of the votes having the right to vote at such meeting. A meeting requested by the membership shall be called for a date not less than fourteen (14) or more than sixty (60) days after the request is made. The call for the meeting shall be issued by the Secretary.

Section 4. Notice of all members' meetings, regular or special, shall be given by the President, Vice President or Secretary of the Association, to each member, unless waived in writing. Such notices shall be written or printed, shall state the time, place and purpose for the meeting, and shall be mailed or personally delivered to each member as follows:

(a) For special meetings, not less than forty-eight (48) hours prior to the date of the meeting, unless the Board determines an emergency, in which event the Board shall give such notice as is reasonable under the circumstances;

(b) For annual meetings, not less than fourteen (14) nor more than sixty (60) days prior to the date set for the meeting; and

(c) For any meetings at which the budget of common expenses will be considered, not less than thirty (30) nor more than sixty (60) days prior to the date of the meeting.

All notices may be sent to members by regular mail. In addition, except in an emergency, when such notice requirement shall be waived, written notice shall be posted at a conspicuous place on the condominium property not less than forty-eight (48) hours prior to any special meeting and not less than fourteen (14) days prior to the annual meeting.

Section 5. Any unit owner may waive notice of a meeting or consent to the holding of a meeting without notice of consent to action taken without a meeting, by execution of a waiver or consent in writing. Such waiver or consent may be executed prior to, at, or subsequent to the meeting of Association action to which the waiver or consent relates.

ARTICLE III

Board of Directors

Section 1. The Board of Directors of the Association shall initially consist of the five (5) persons named in the Articles of Incorporation of the Association and the number may be increased or decreased from time to time but shall not be less than five, nor more than nine persons. Thereafter, subject to the provisions of the Declaration, the directors shall be elected at the annual membership meeting, and shall hold office for a term of one year or until their successors shall be elected and qualified. At each election for directors, each member shall be entitled to vote for as many persons as there are directors to be elected. No cumulative voting shall be permitted. The candidates receiving the highest number of votes shall be declared elected.

Section 2. After the first election of all directors by the membership, each director shall be a unit owner or the spouse of a unit owner (or, if a unit owner is a corporation, partnership, or trust, a director may be an officer, partner or beneficiary of such unit owner). If a director shall cease to meet such qualifications during his term, he shall thereupon cease to be a director and his place on the Board shall be deemed vacant.

Section 3. Any vacancy occurring in the Board may be filled by a majority vote of the remaining members thereof.

Section 4. An annual meeting of the Board shall be held immediately following the annual meeting of the membership and at the same place. Special meetings of the Board shall be held upon call by the President or a majority of the Board on not less than forty-eight (48) hours notice in writing to each director, unless the Board determines an emergency to exist, in which event the Board shall give such notice as is reasonable under the circumstances. All meetings of the Board of Directors shall be open to unit owners and, except in an emergency as provided above, notices of all meetings shall be posted in a conspicuous place on the condominium property at least forty-eight (48) hours prior to the meeting. However, unit owners shall not be entitled to vote or participate in any other way at the meeting.

Section 5. Any director or unit owner may waive notice of a meeting or consent to the holding of a meeting

without notice or consent to any action of the Board without a meeting. Such waiver or consent may be executed prior to, at or subsequent to, the meeting or Board action, to which the waiver or consent relates.

Section 6. A quorum for the transaction of business shall consist of a majority of the directors. However, less than a quorum may adjourn a meeting from time to time. A majority of directors who are present at any meeting where a quorum is present, may decide any question before the meeting.

Section 7. Any director may be removed from office, with or without cause, by at least a majority vote of all unit owners, at a duly called meeting of unit owners. Notwithstanding any other provisions herein, a special meeting of unit owners to remove a director or directors from office may be called by 10% of all unit owners giving notice to all owners of the meeting, which notice shall state the purpose of the meeting and shall be given to all unit owners in writing in the same manner as required by these By Laws for special meetings of unit owners.

Section 8. Directors shall receive no compensation for their services, unless expressly provided for in resolutions duly adopted by the unit owners.

Section 9. The Board shall have the following powers and duties:

(a) To elect the officers of the Association as hereinafter provided;

(b) To administer the affairs of the Association and the condominium;

(c) To employ a general manager or management company who shall manage and operate the condominium for all of the Unit Owners, upon such terms and for such compensation and with such authority as the Board may approve;

(d) To formulate policies for the administration, management and operation of the condominium;

(e) To adopt administrative rules and regulations governing the administration, management, operation and use of the condominium, and to amend such rules and regulations from time to time;

(f) To provide for the maintenance, repair and replacement of the common elements and limited common elements, if any, and payments therefor;

(g) To provide for the designation, hiring and removal of employees and other personnel, including accountants; to engage or contract for the services of other; to make purchases for the maintenance, repair, replacement, administration, management and operation of the condominium and the condominium property; and to delegate any such powers to the employees or agents of the Association;

(h) To estimate the amount of the annual budget, and to provide the manner of assessing and collecting from the unit owners their respective shares of such estimated expenses as hereinafter provided and to assess any supplemental assessment as the Board shall deem necessary;

(i) Unless otherwise provided herein or in the Declaration, to comply with the instructions of a majority of the unit owners, as expressed in a resolution duly adopted at any annual or special meeting of the unit owners;

(j) To exercise all other powers and duties of the Board provided for in the Declaration, the Certificate of Incorporation of the Association and Chapter 718, Florida Statutes, the Condominium Act of the State of Florida, as amended from time to time.

ARTICLE IV

Officers

Section 1. Subject to the provisions of the Declaration, at each annual meeting of the Board, the Board shall elect from the membership of the Association the following officers of the Association:

(a) A President, who shall be a director, shall preside over the meetings of the Board and of the unit owners, and shall be the chief executive officer of the Association. Subject to direction of the Board of Directors, the President shall have general control and management of the business and affairs of this Association.

(b) A Vice President, who shall, in the absence or disability of the President, perform the duties and exercise the powers of the President;

(c) A Secretary, who shall keep the minutes of all meetings of the Board and of the membership and who shall

perform all the duties generally incident to the office of Secretary;

(d) A Treasurer, who shall cease to be properly kept, the financial records and books of account of the Association; and

(e) Such additional officers as the Board desires to elect.

Section 2. Each officer shall hold office for the term of one year and until his successor shall have been elected and qualified.

Section 3. Vacancies in any office shall be filled by the Board at special meetings thereof. Any officer may be removed at any time, with or without cause, by the affirmative vote of a majority of the whole Board.

Section 4. Officers shall receive no compensation for their services, unless expressly provided for in a resolution duly adopted by the unit owners.

ARTICLE V.

Assessments

Section 1. The Board shall cause an estimated annual budget for each fiscal year of the Association to be prepared prior to the beginning of the fiscal year. The budget shall take into account the estimated common expenses and cash requirements for the year including salaries, wages, payroll taxes, supplies, materials, parts, services, utilities, maintenance,

repairs, replacements, landscaping, insurance, fuel, power and other common expenses (as distinguished from individual mortgage payments, real estate taxes and individual telephone, electricity and other individual utility expenses billed or charged to the unit owners on an individual or separate basis rather than a common basis). The annual budget shall also take into account the estimated net available cash income for the year and a reserve for replacements in reasonable amounts as determined by the Board. To the extent that the assessments and other cash income collected from the unit owners during the preceding year shall be more or less than the expenditures for such preceding year, the surplus or deficit, as the case may be, shall also be taken into account.

Section 2. The estimated annual budget for each fiscal year as prepared by the Board, shall be approved by a majority of all unit owners. A copy of the proposed annual budget shall be mailed to unit owners not less than thirty (30) days prior to the meeting at which the budget is to be considered, together with notice of the meeting, specifying the time and place at which it will be held.

Section 3. Each unit owner shall pay, on or before the first day of each month, as his respective monthly assessment for the common expenses, one-twelfth (1/12) of his proportionate share of the annual budgeted common expenses. Each Unit Owner's proportionate share shall be in accordance with

his respective ownership interest in the common elements as set forth in the Declaration. The Board may send to each unit owner on or before the first day of each month a statement of the monthly assessment of such unit owner for such month, but the failure to receive such monthly statement shall not relieve any unit owner of his obligation to pay his monthly assessment. In the event that the Association shall not approve an estimated annual budget or shall fail to determine new monthly assessments for any year, or shall be delayed in doing so, each unit owner shall continue to pay each month the amount of his respective monthly assessment as last determined. No unit owner shall be relieved of his obligation to pay his assessments for common expenses by abandoning or not using his condominium parcel or the common elements.

Section 4. If it shall appear to the Board during a fiscal year that the monthly assessments, determined in accordance with the estimated annual budget for such year, are insufficient or inadequate to cover the estimated common expenses for the remainder of such year, then the Board shall prepare and approve a supplemental budget covering the estimated deficiency for the remainder of such year, furnish copies to each unit owner, and make a supplemental assessment to each unit owner for his proportionate share of such supplemental budget; provided, however, that no supplemental budget shall require assessment greater than 115% of assessments for the previous fiscal year, without approval of a majority of the

unit owners. If the Board determines that a supplemental budget is required which will exceed the above limitations, it shall call a meeting of unit owners to consider such budget, giving notice of such meeting as required in these By Laws for any meeting at which a budget is to be considered.

Section 5. The Board may from time to time require each unit owner to deposit with the Association a reasonable deposit for working capital or contingent expenses to be the same proportion of the total deposit as his percentage ownership in the common elements.

Section 6. If the first fiscal year of the Association, or any succeeding fiscal year, shall be less than a full calendar year, then the monthly assessments for each unit owner shall be proportionate to the number of months and days in the period covered by such budget. A unit owner shall pay his assessment commencing with the date of purchase of his condominium parcel for the following month or fraction of a month, which assessment shall be in proportion to his respective ownership interest in the common elements and the number of months and days remaining of the period covered by the current annual budget.

Section 7. The Board shall maintain adequate accounting records according to approved accounting practices, which records shall be open to inspection by unit owners at reasonable times and upon reasonable notice. These accounting records shall include a record of receipts and expenditures and

a separate account for each unit owner showing the assessments charged to and paid by such owner. Within ninety (90) days after the end of each budget year, or as soon thereafter as shall be practicable, the Board shall furnish to each unit owner a statement for that year, showing the receipts and expenditures and such other information as the Board may desire.

Upon reasonable notice to the Board, any unit owner shall be furnished a statement of his account setting forth the amount of any unpaid assessments or other charges due and owing from him.

Section 8. Without the approval of the unit owners holding a majority of the votes of the Association, the Board shall not approve any capital expenditures in excess of five thousand dollars (\$5,000.00) other than rebuilding, repairing or replacing damaged property and exercising the Association's right of first refusal to purchase units.

Section 9. Every unit owner shall pay his proportionate share of the common expenses, in the same ratio as his percentage of ownership in the common elements as set forth in the Declaration and any special assessments assessed against his condominium parcel in the manner herein provided. If any unit owner shall fail or refuse to make any such payment of the common expenses or any special assessments when due, the amount thereof shall constitute a lien on the interest of such unit owner in his unit and its appurtenances. The Association and the Board shall have the authority to exercise

and enforce any and all rights and remedies as provided for in the Condominium Act, the Declaration or these By Laws or otherwise available at law or in equity, for the collection of all unpaid assessments.

Section 11. The Board of Directors may cause the Association to discharge any mechanic's lien or other encumbrance which in the opinion of the Board may constitute a lien against the common elements or limited common elements, if any, of the condominium. When less than all the unit owners responsible for the existence of any such lien, the unit owners responsible shall be jointly and severally liable for the amount necessary to discharge the same and for all costs and expenses (including attorney's fees) incurred by reason of such lien.

Section 12. The Board of Directors may levy special assessments against one or more of the condominium parcels to pay to improvements, repairs or replacements which are attributable only to those condominium parcels in accordance with the terms of the Declaration. Special assessments shall be due and payable within fifteen (15) days after notice thereof is given unless the notice shall specify a longer period.

ARTICLE VI

Use and Occupancy Restrictions

Section 1. No part of the condominium shall be used for other than residential purposes for which the condominium was designed. Each occupant, whether owner or tenant, shall

comply with all the restrictions upon use set out in the Declaration.

Section 2. Uniform Rules and Regulations governing the use of the condominium and the conduct of persons entitled to so use the condominium property shall be promulgated from time to time by the Board of Directors. All unit owners shall obey the Rules and Regulations as promulgated by the Board.

ARTICLE VII

Amendment

These By Laws may be amended, altered or rescinded by members having a majority of the votes of the Association either in writing or by vote at a regular or special meeting of the members, notice of which shall state that such proposed amendment is to be voted upon at the meeting. All amendments of these By Laws shall be duly recorded as an Exhibit to the Declaration, in the public records of the county in which the condominium property is located.

EXHIBIT 4

DEF REC 565 PAGE 608

OCEAN VILLAS CONDOMINIUM
 ESTIMATED INITIAL 12-MONTH
 OPERATING BUDGET
 (Phase I - 72 Units)

	<u>Monthly</u>	<u>Annually</u>
Operating Expenses - Administrative		
Management Expenses	\$ 1,200	\$ 14,400
Telephone	50	600
Printing; Postage	35	420
Dues and Fees (1)	10	120
Legal and Accounting	50	600
Operating Expenses - Buildings		
Electricity	250	3,000
Trash Removal	160	1,920
Building Maintenance/Supplies	50	600
Insurance (multiperil/wind/ storm/flood)	1,300	15,600
Water, sewage, cable TV	1,620	19,440
Operating Expenses - Grounds		
Grounds/Landscaping	450	5,400
Pool Supplies/Repairs	250	3,000
Reserves (2)		
Roof Replacement	200	2,400
Parking Lot, Driveways	250	3,000
Painting	200	2,400
Contingency	<u>300</u>	<u>3,600</u>
TOTAL:	\$ 6,375	\$ 76,500

Notes:

- (1) Includes \$.50 per year per unit to Division
 (2) Based on replacement costs

The assessment for each unit will be \$88.54 per month or \$1,062.50 per year.

The Developer shall be excused from payment of his share of the common expense assessed against those units of the condominium owned by the Developer subsequent to recordation of this Declaration of Condominium. However, the period during which the Developer is excused from payment of Common Expenses shall terminate no later than the first day of the fourth calendar month following the month in which the closing of the purchase and sale of the first condominium unit occurs.

During the time period the Developer is excused from payment of Common Expenses assessed against units in the Condominium, Developer shall pay the portion of Common Expenses incurred which exceed the total amount of Common Expenses assessed against other unit owners.

OCEAN VILLAS CONDOMINIUM
ESTIMATED OPERATING BUDGET
(Phases I and II - 138 Units)

OFF REC 565 PAGE 609

	<u>Monthly</u>	<u>Annually</u>
Operating Expenses - Administrative		
Management Expenses	\$ 2,355	\$ 28,260
Telephone	96	1,152
Printing; Postage	68	816
Dues and Fees (1)	19	228
Legal and Accounting	95	1,140
Operating Expenses - Buildings		
Electricity	479	5,748
Trash Removal	306	3,672
Building/Maintenance/Supplies	95	1,140
Insurance (multiperil/wind/storm flood)	2,493	29,916
Water, sewage, Cable TV	3,100	37,200
Operating Expenses - Grounds		
Grounds/Landscaping	863	10,356
Pool Supplies/Repairs	479	5,748
Reserves (2)		
Roof Replacement	384	4,608
Parking Lot/Driveways	479	5,748
Painting	384	4,608
Contingency	<u>435</u>	<u>5,220</u>
TOTAL:	\$12,130	\$ 145,560

Notes:

- (1) Includes \$.50 per year per unit to Division
- (2) Based on replacement costs

The assessment for each unit will be \$87.90 per month or \$1,054.78 per year.

The Developer shall be excused from payment of his share of the common expenses assessed against those units of the condominium owned by the Developer subsequent to recordation of this Declaration of Condominium. However, the period during which the Developer is excused from payment of Common Expenses shall terminate no later than the first day of the fourth calendar month following the month in which the closing of the purchase and sale of the first condominium unit occurs.

During the time period the Developer is excused from payment of Common Expenses assessed against units in the Condominium, Developer shall pay the portion of Common Expenses incurred which exceed the total amount of Common Expenses assessed against other unit owners.

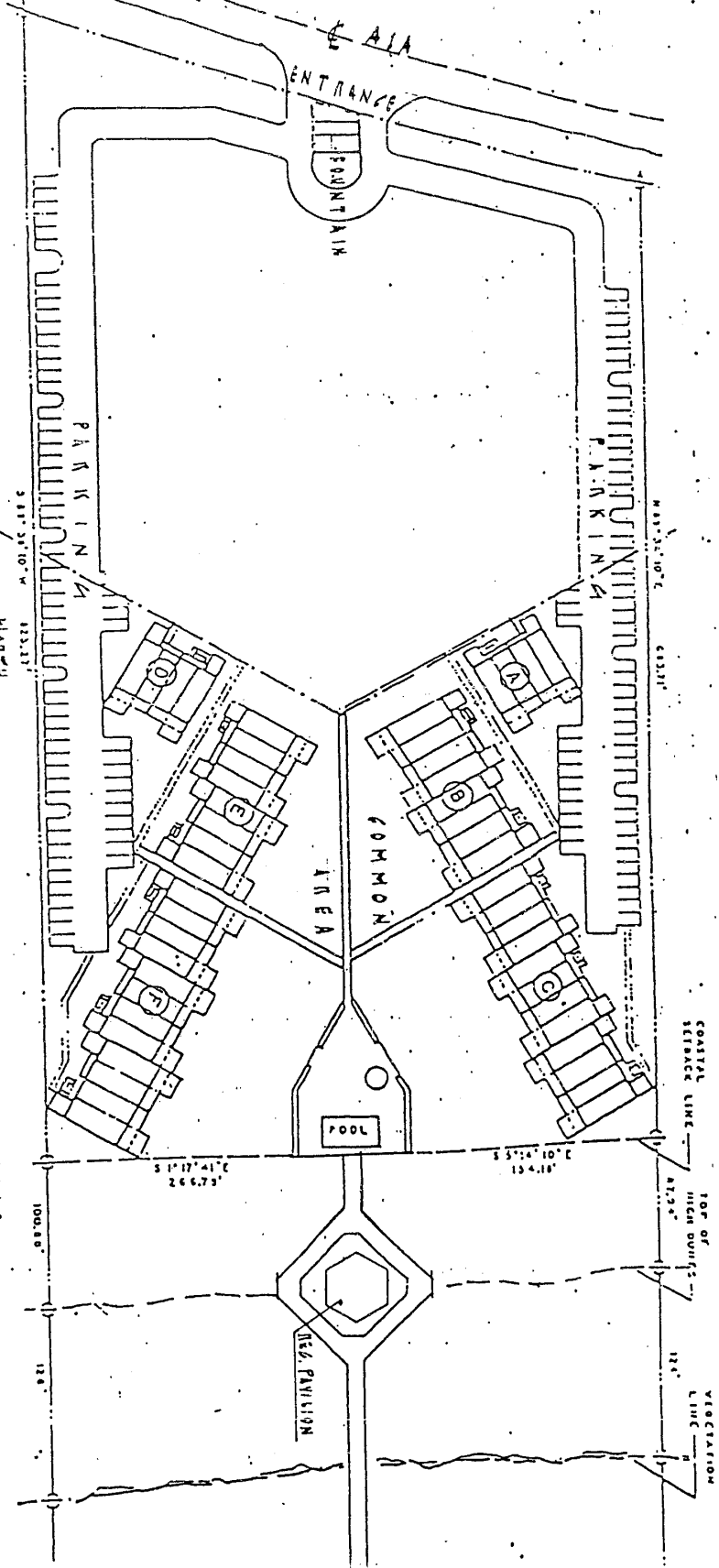

PROPOSED SITE PLAN PHASE I
 OCEAN VILLAS CONDOMINIUM
 NORTH

SCALE: 0 50' 100'
 9/27/82

M.K. HUNTER & ASSOCIATES ARCHITECTS
 1606 NW 6 ST. KALAMAZOO MI 49001
 ALL STRUCTURES ON SITE ARE PROPOSED

NOTE: MAXIMUM BUILDING
 HEIGHT: 36'0" ABOVE 1ST FLOOR SLAB

41A

ENTRANCE

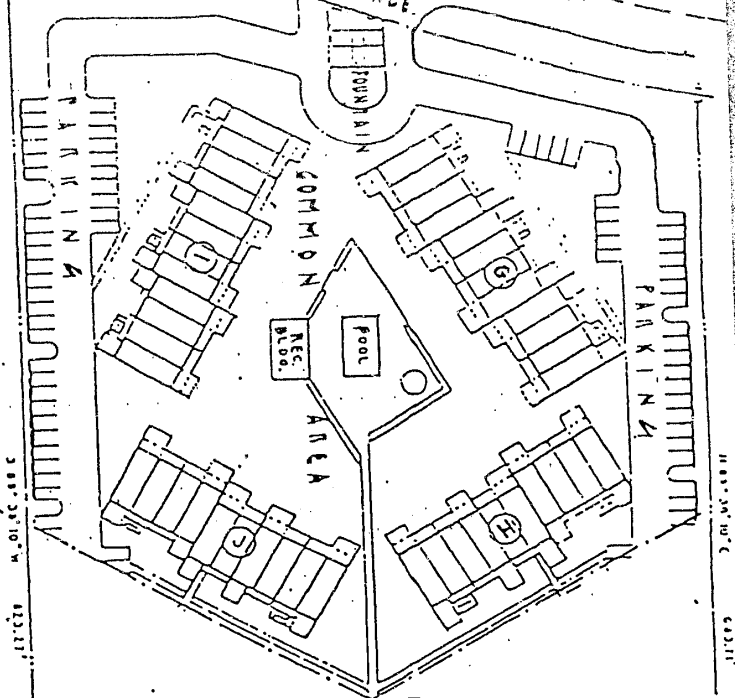

PHASE I

PROPOSED SITE PLAN PHASE I
OCEAN VILLAS CONDOMINIUM

SCALE 1" = 50' 1/8" 9/27/82

J. K. HUNTER, JR., AIA ARCHITECT
1606 NW 6 ST., GAINESVILLE, FLORIDA 32601

ALL STRUCTURES ON SITE ARE PROPOSED

NOTE: MAXIMUM BUILDING
HEIGHT: 36' 0" ABOVE 1ST FLR SLAB

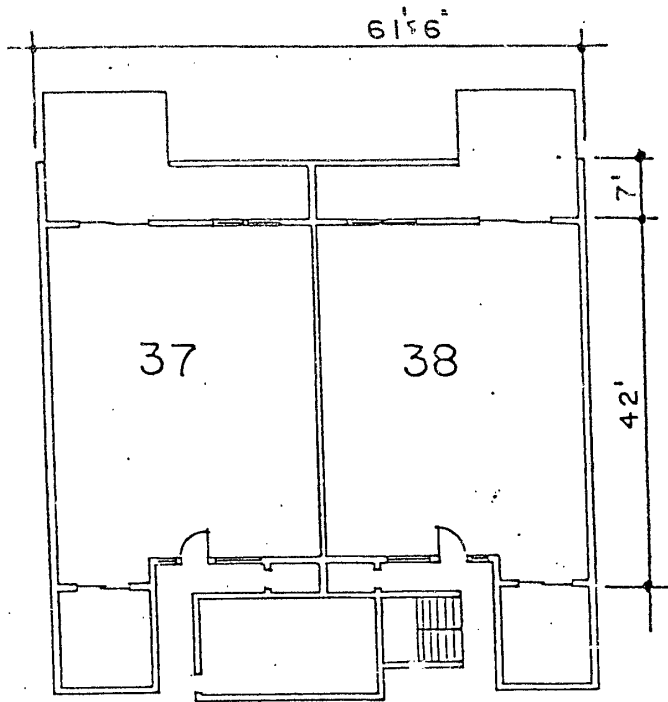

BUILDING "A"

FIRST FLOOR

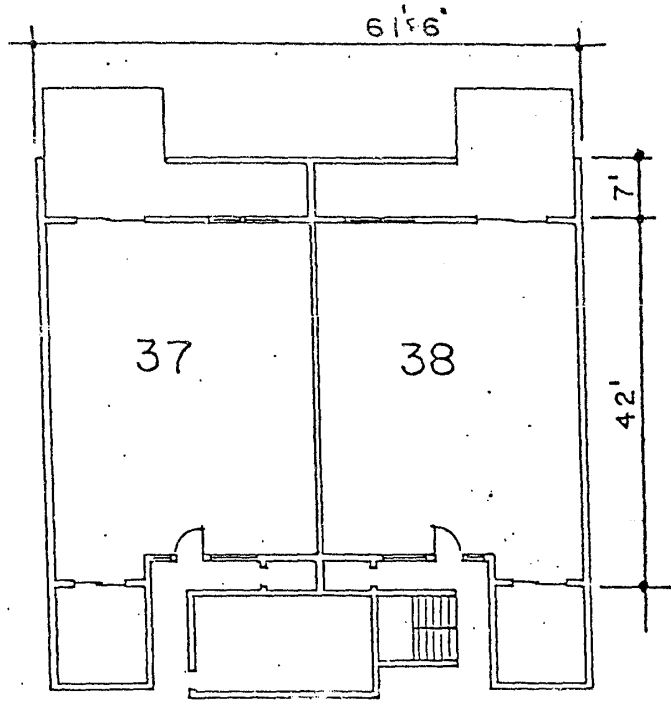

BUILDING "A"

FIRST FLOOR

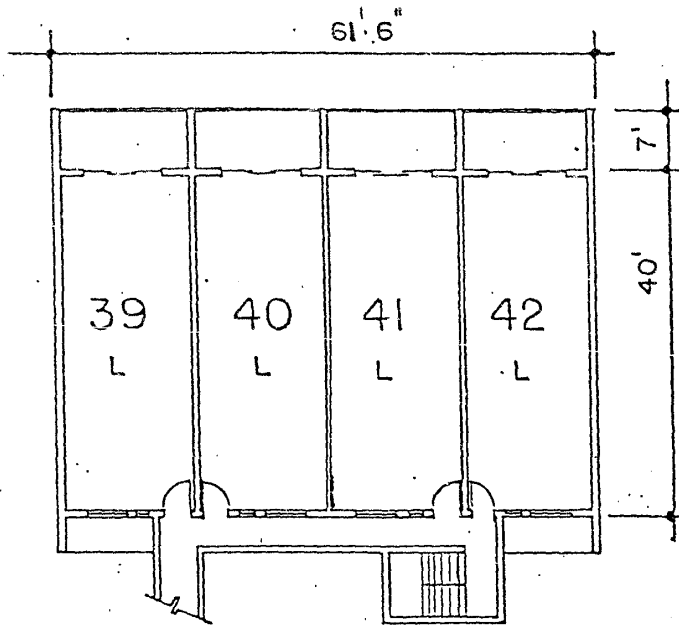

BUILDING "A"

SECOND FLOOR

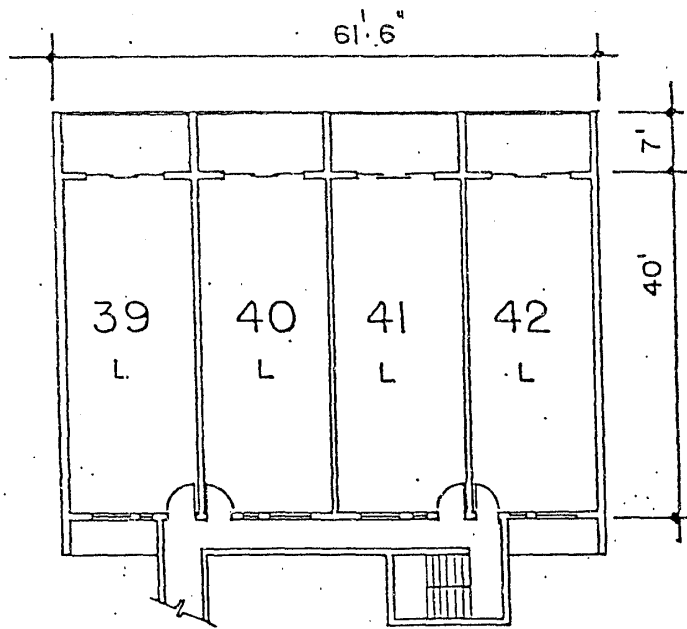

BUILDING "A"

SECOND FLOOR

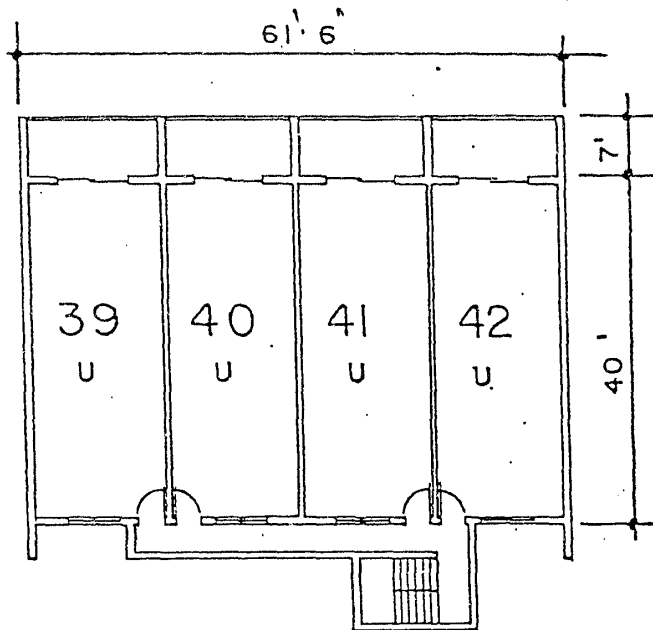

BUILDING "A"

THIRD FLOOR

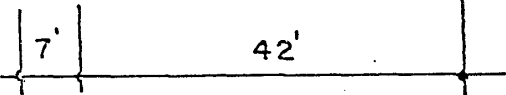
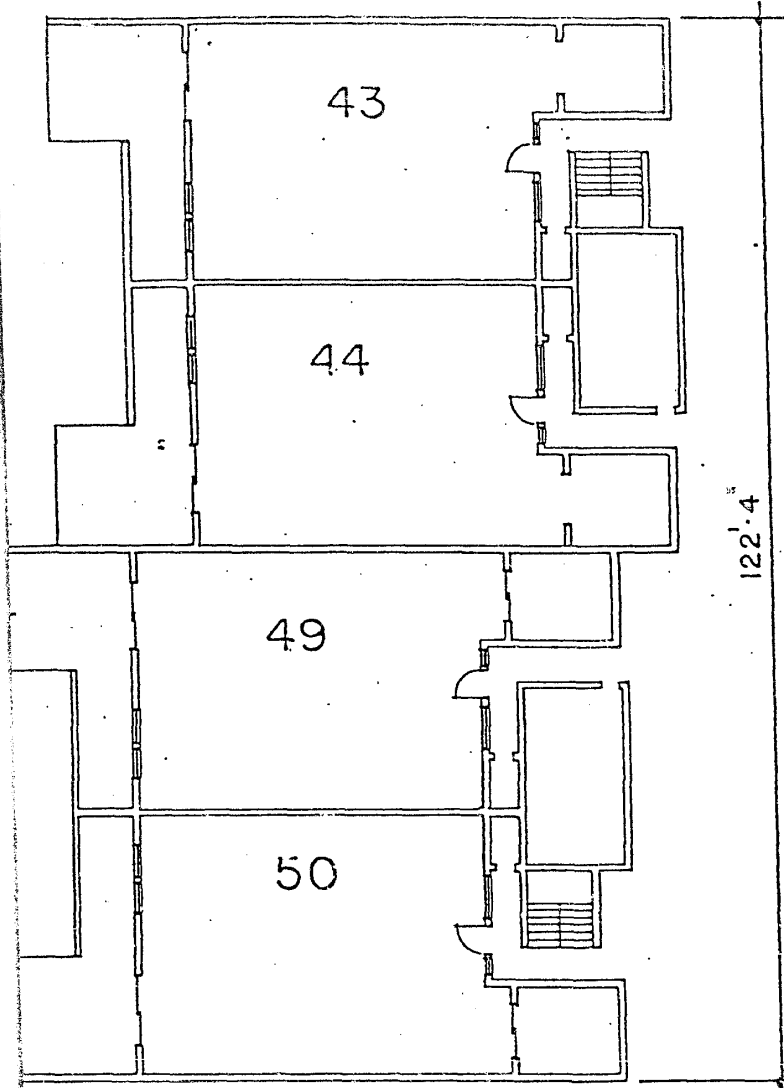

BUILDING "B"

FIRST FLOOR

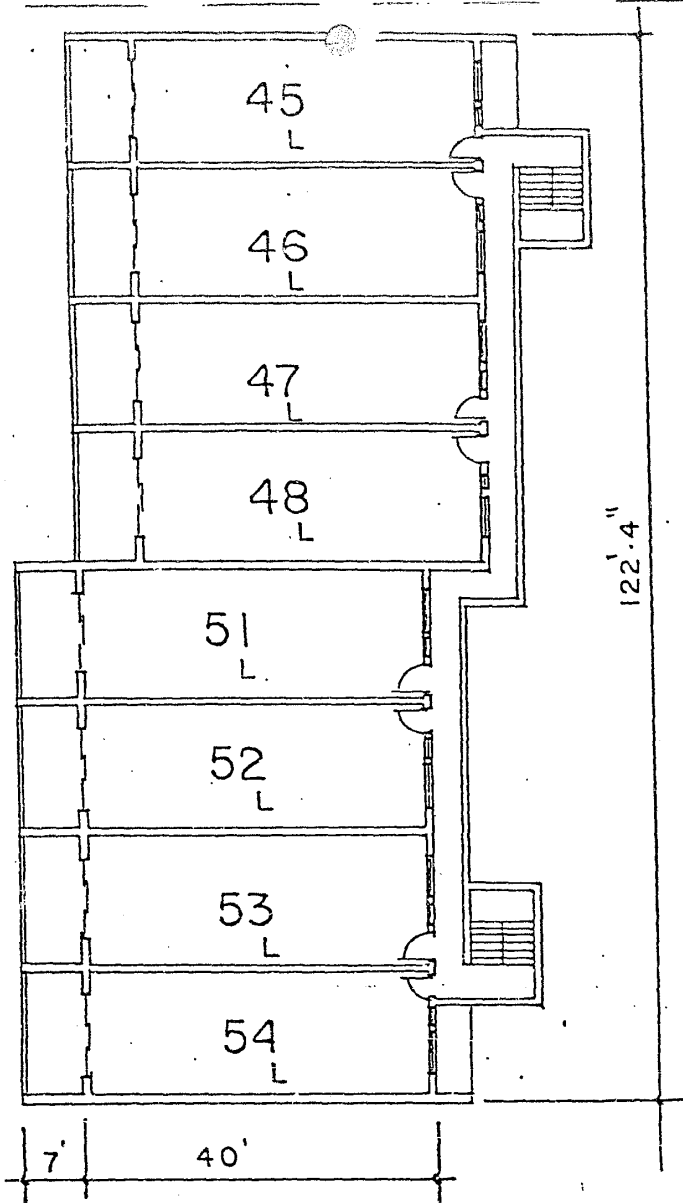

BUILDING "B"

SECOND FLOOR

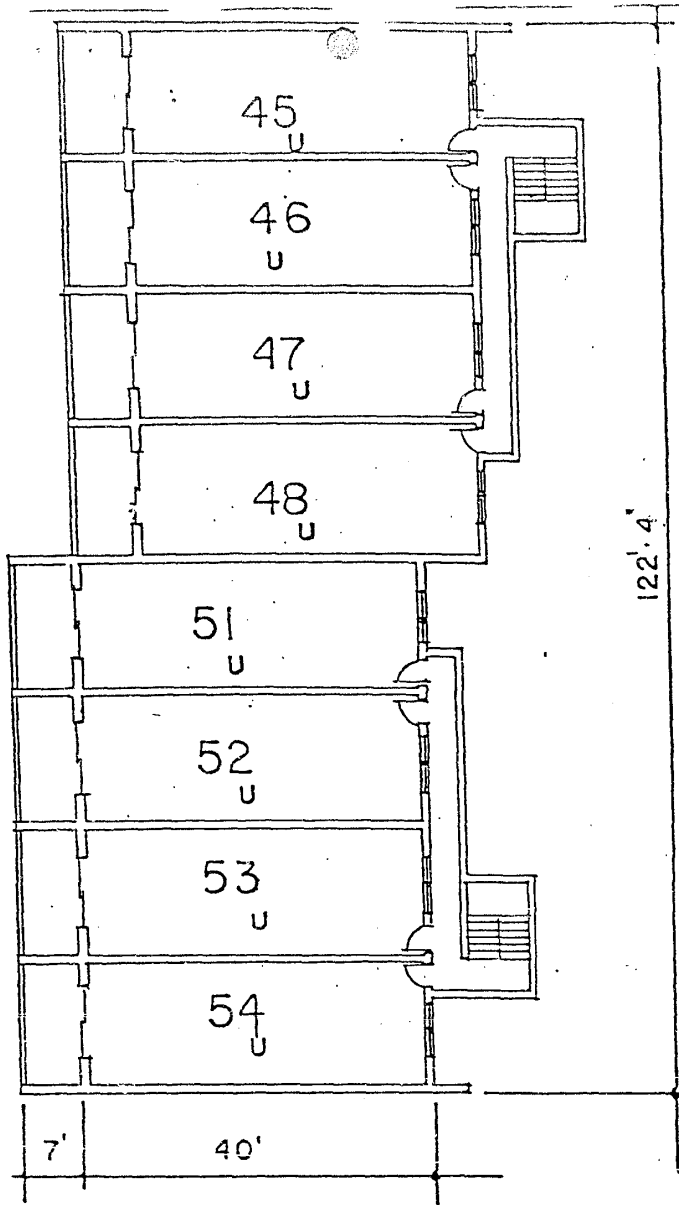

BUILDING "B"

THIRD FLOOR

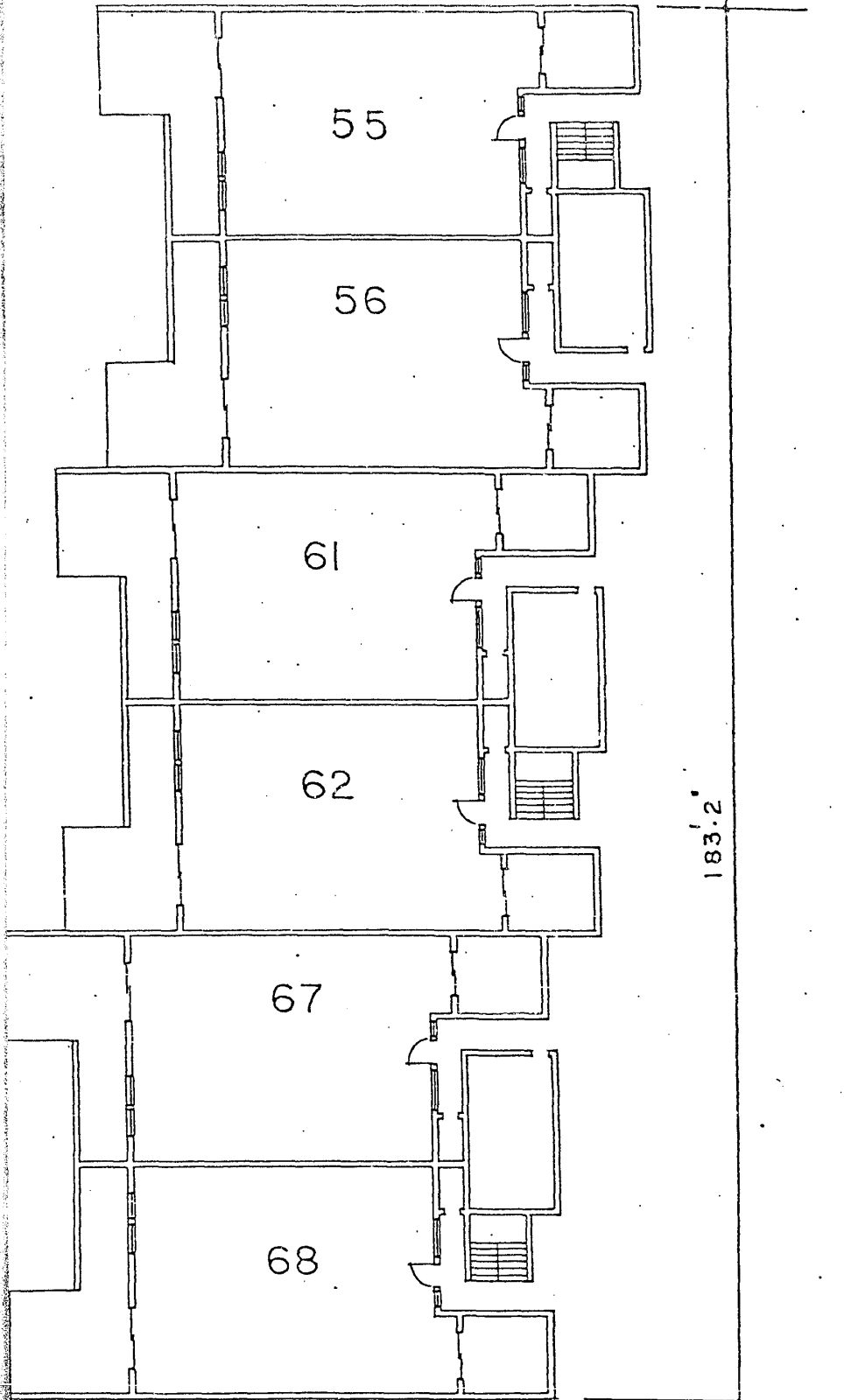

183'-2"

7' 42'

BLDG. "C"

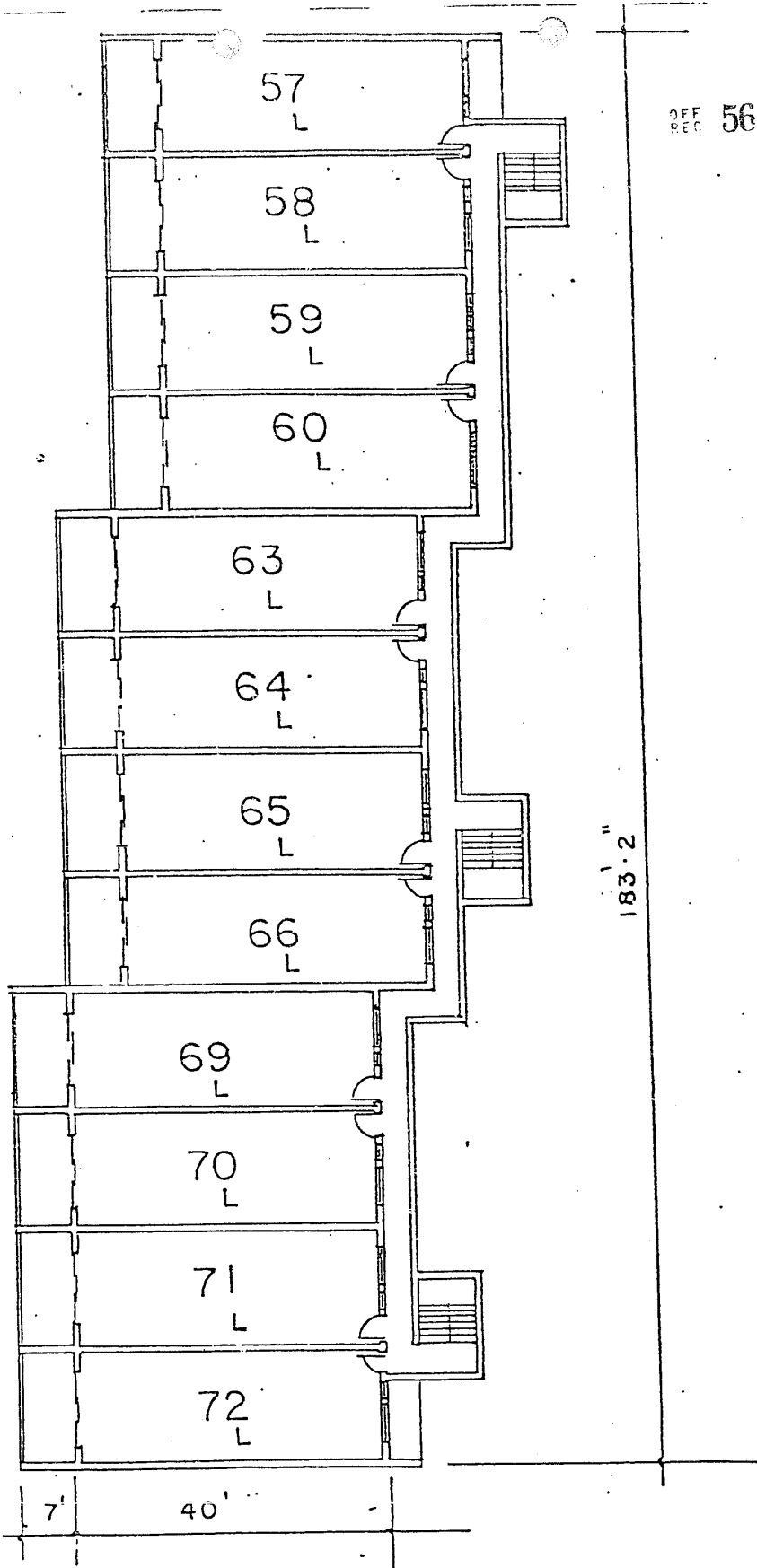

183'-2"

BLDG. "C"

SECOND FLOOR

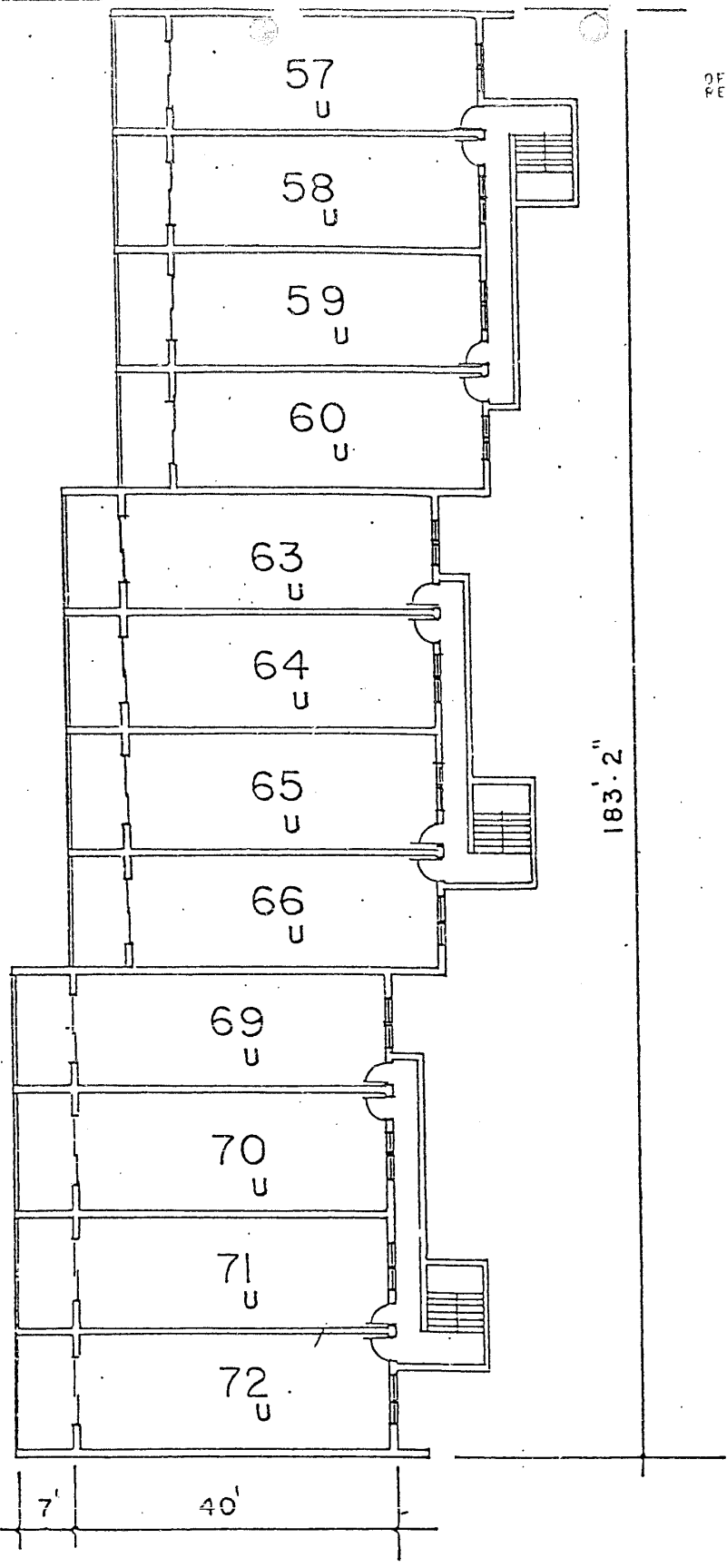

BLDG. "C"

THIRD FLOOR

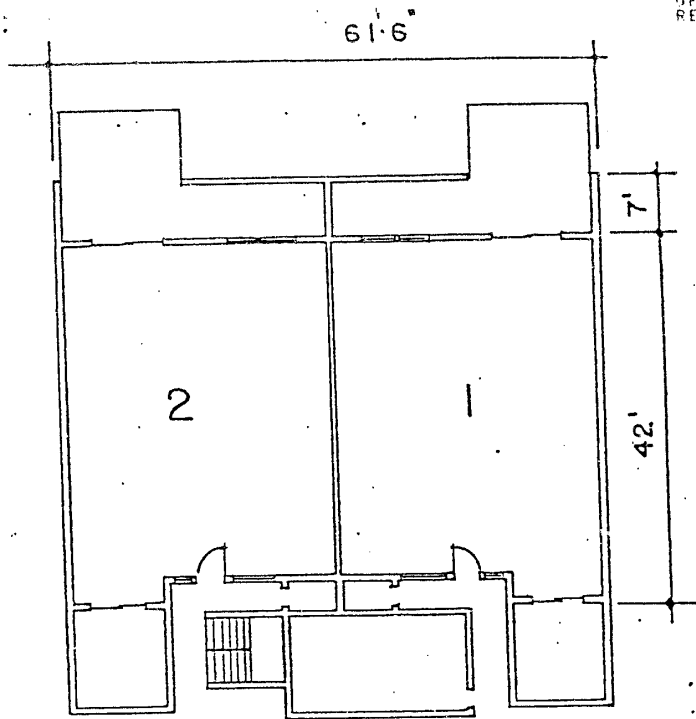

BUILDING "D"
FIRST FLOOR

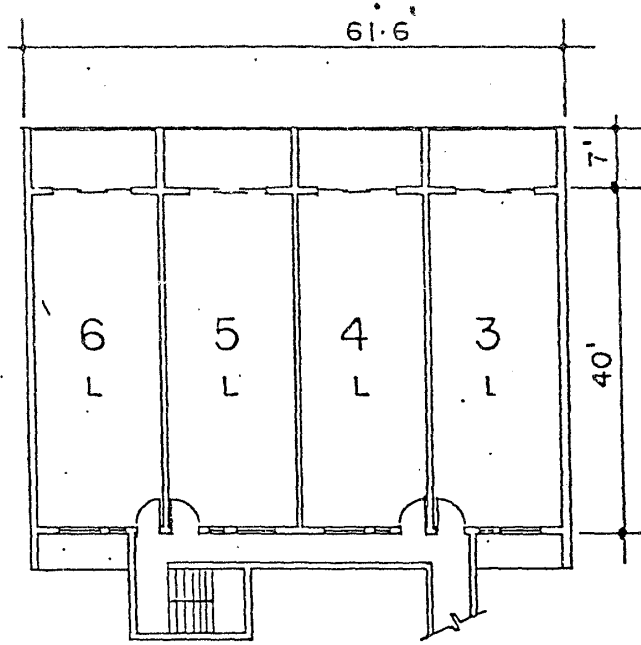

BUILDING "D"

SECOND FLOOR

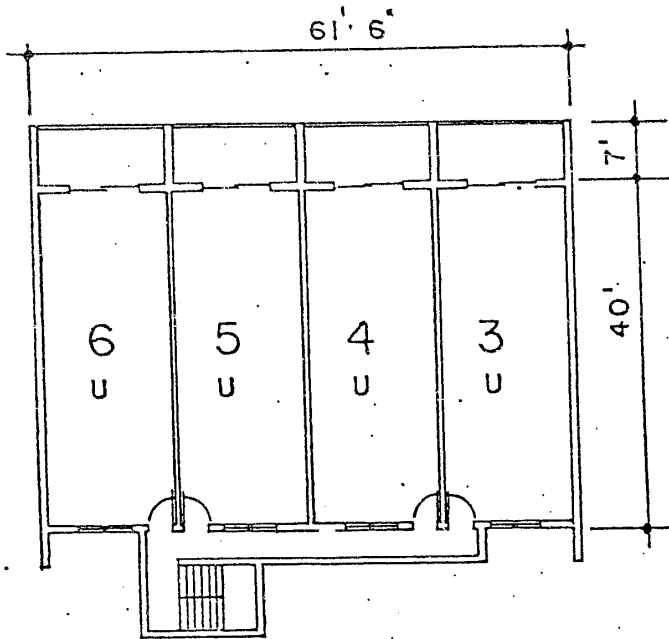

BUILDING "D"

THIRD FLOOR

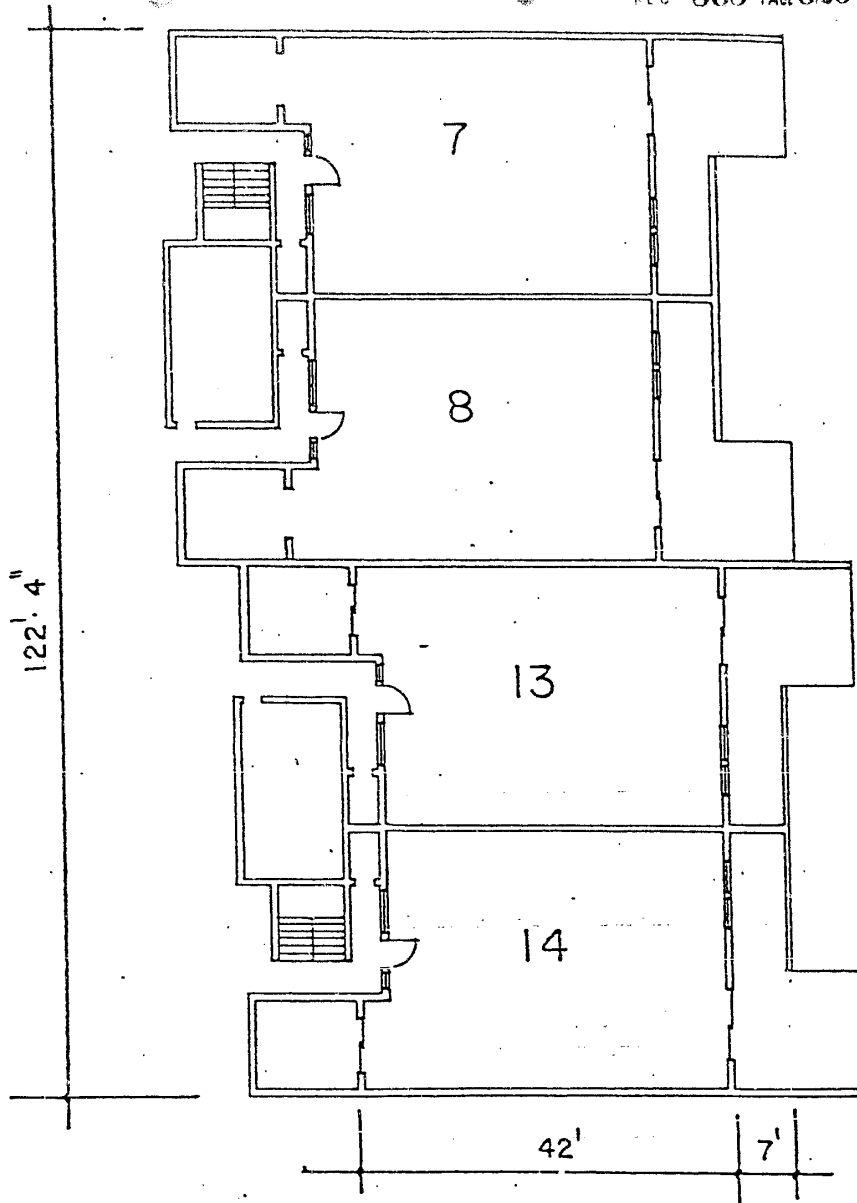

BUILDING "E"

FIRST FLOOR

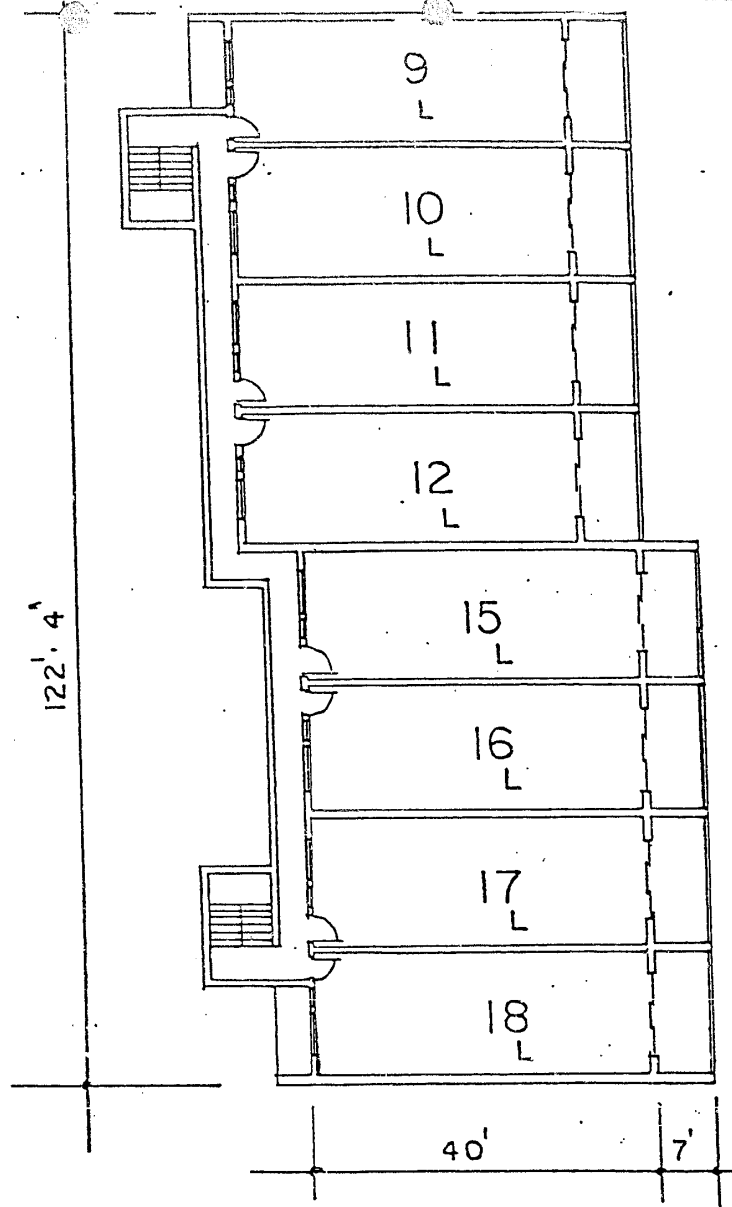

BUILDING "E"
SECOND FLOOR

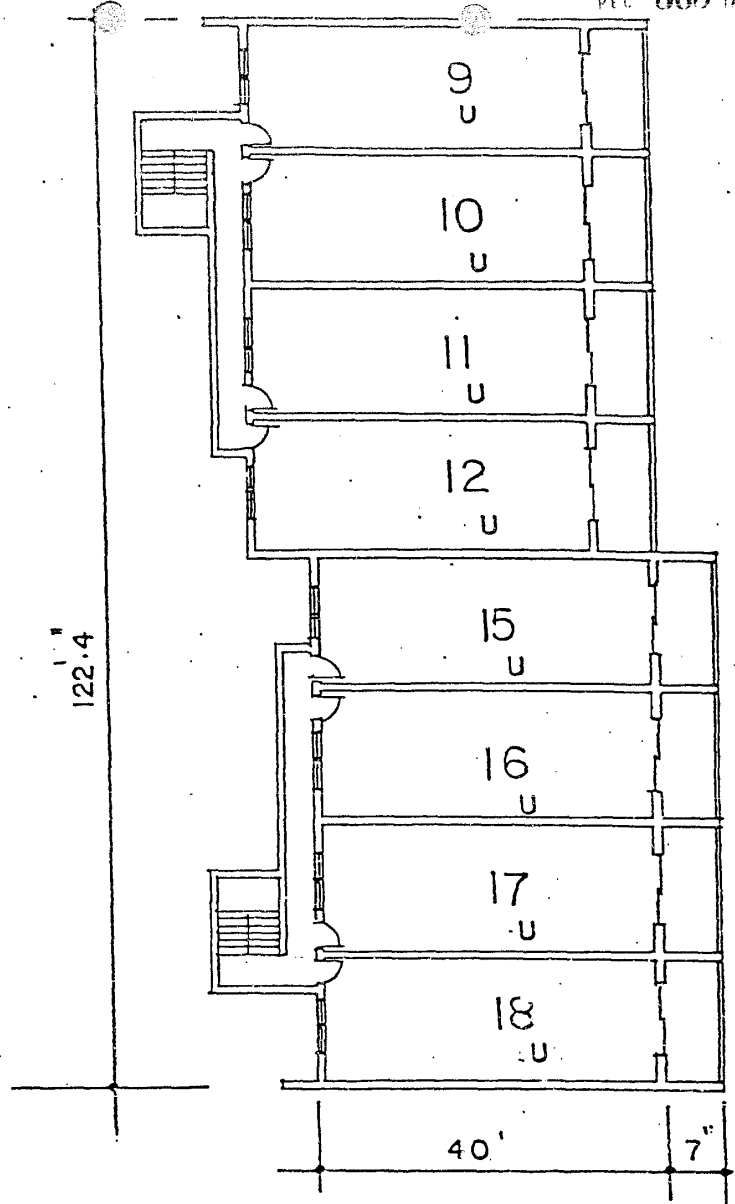

BUILDING "E"

THIRD FLOOR

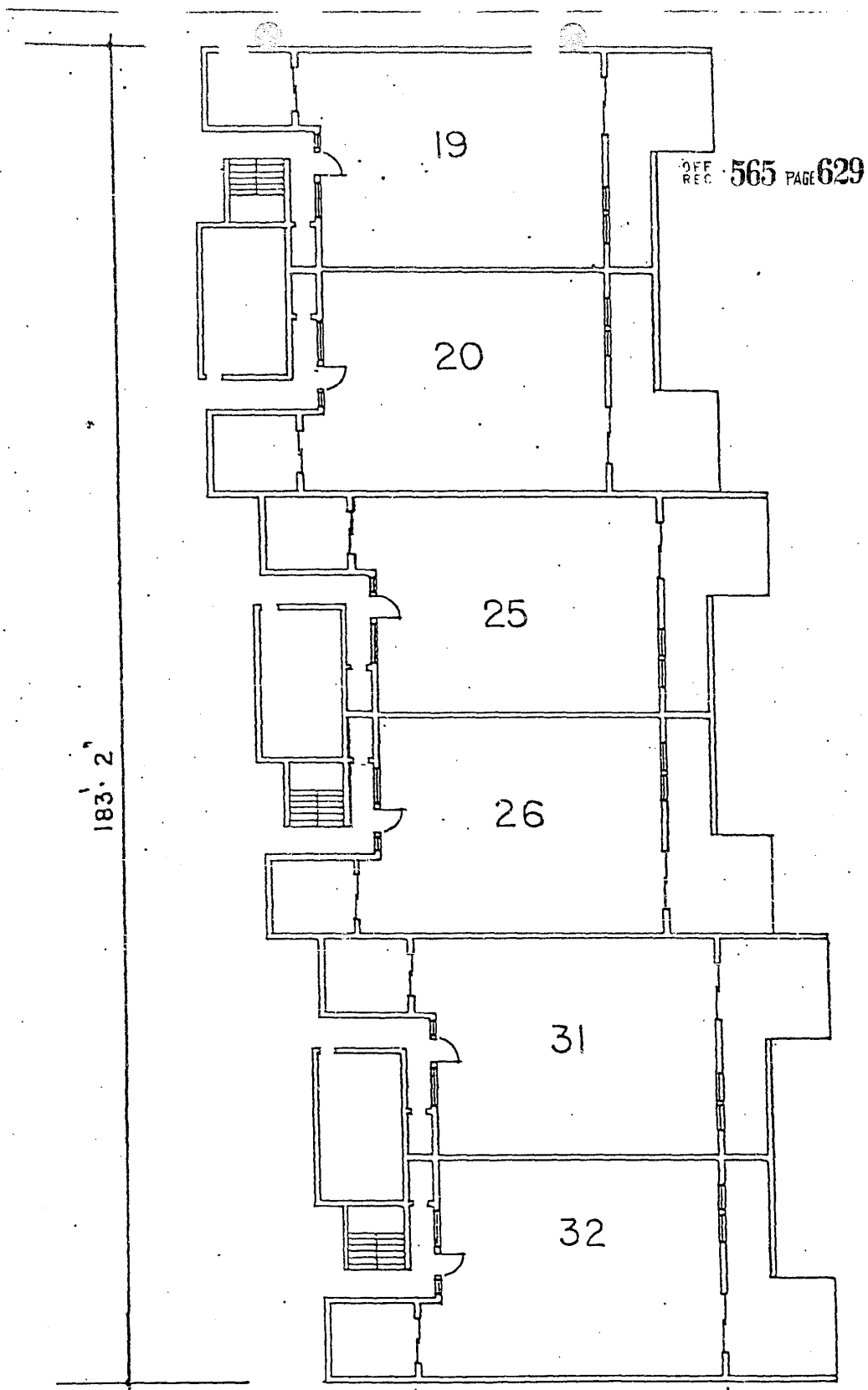

BLDG. "F"

FIRST FLOOR

183' 2"

BLDG. "F"

SECOND FLOOR

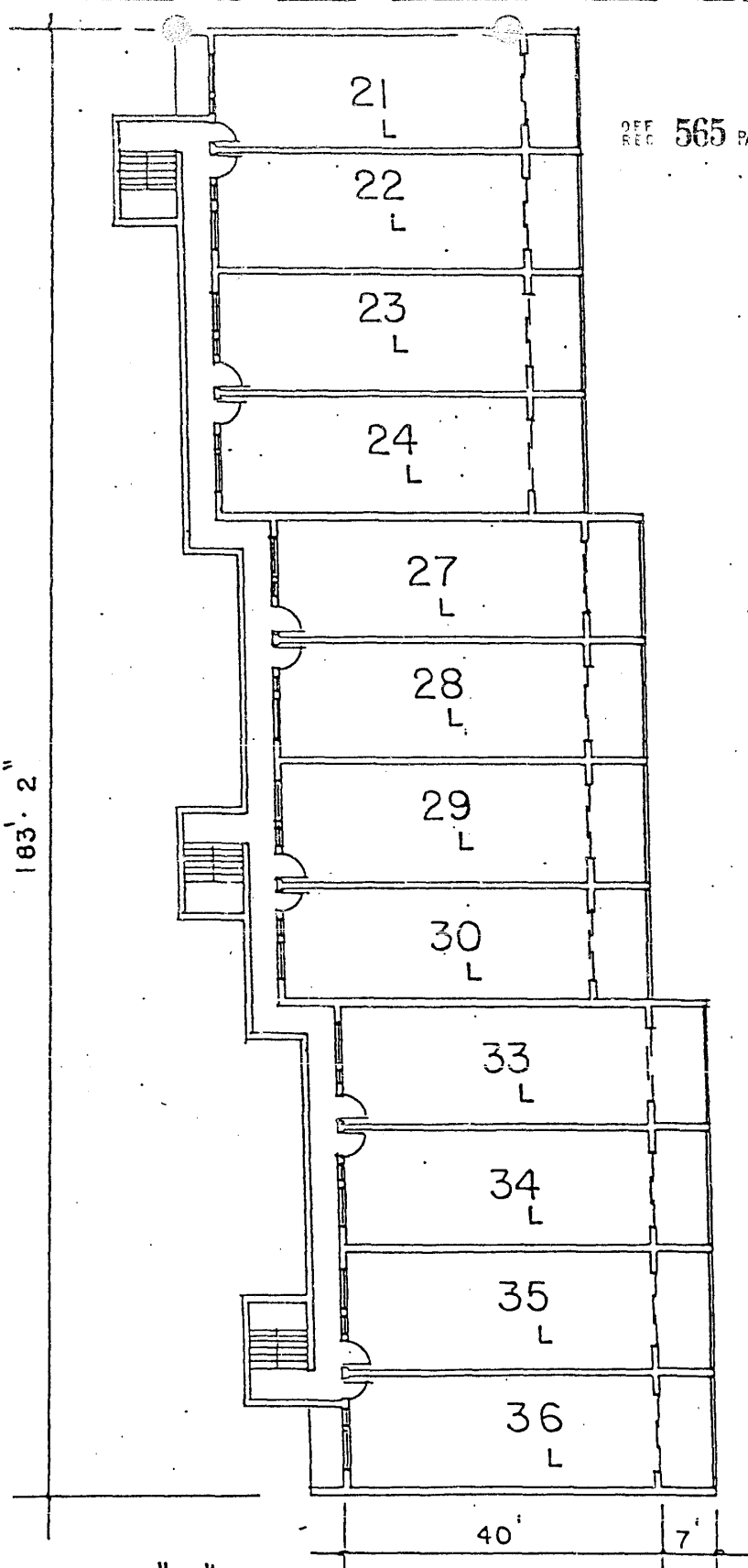

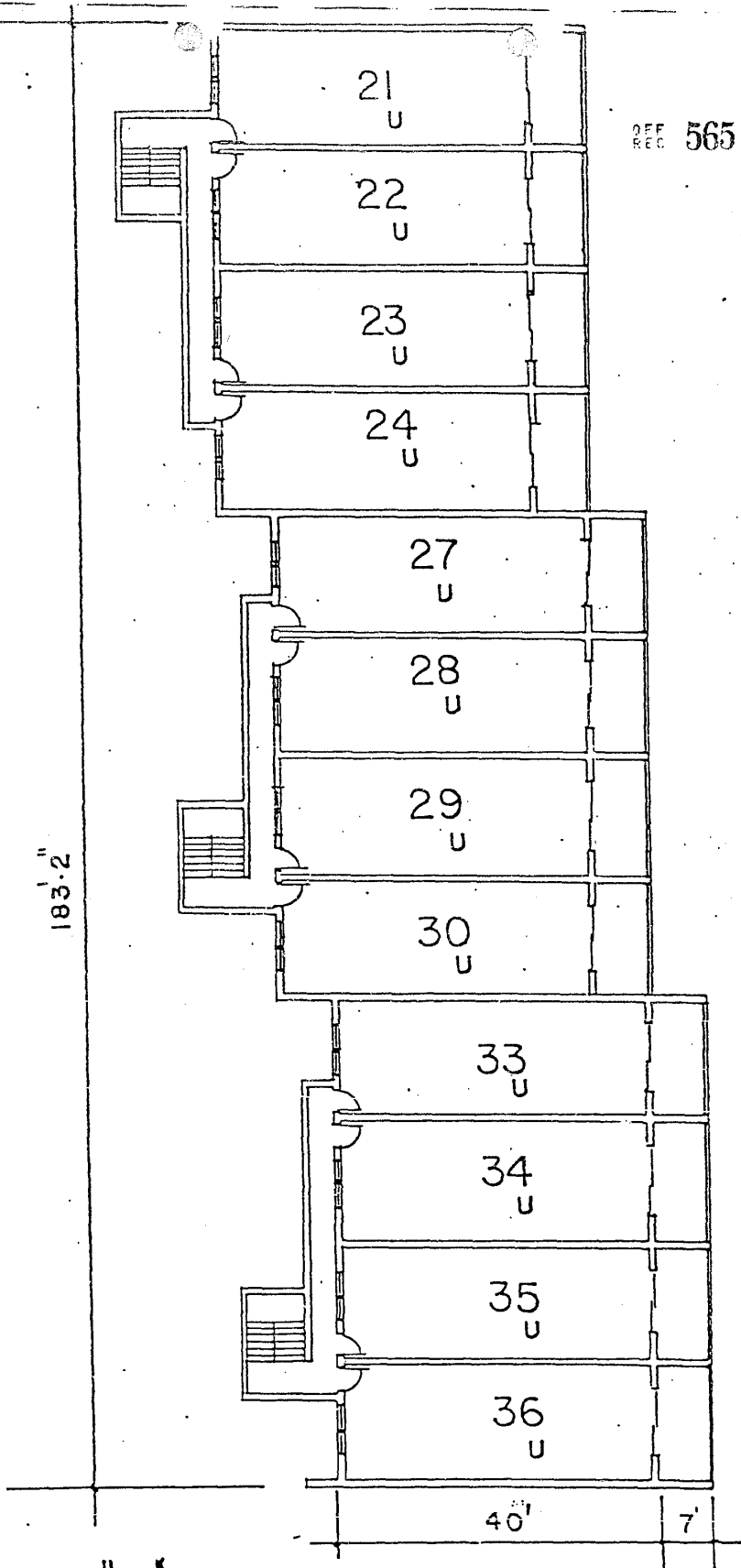

BLDG. "F"

THIRD FLOOR

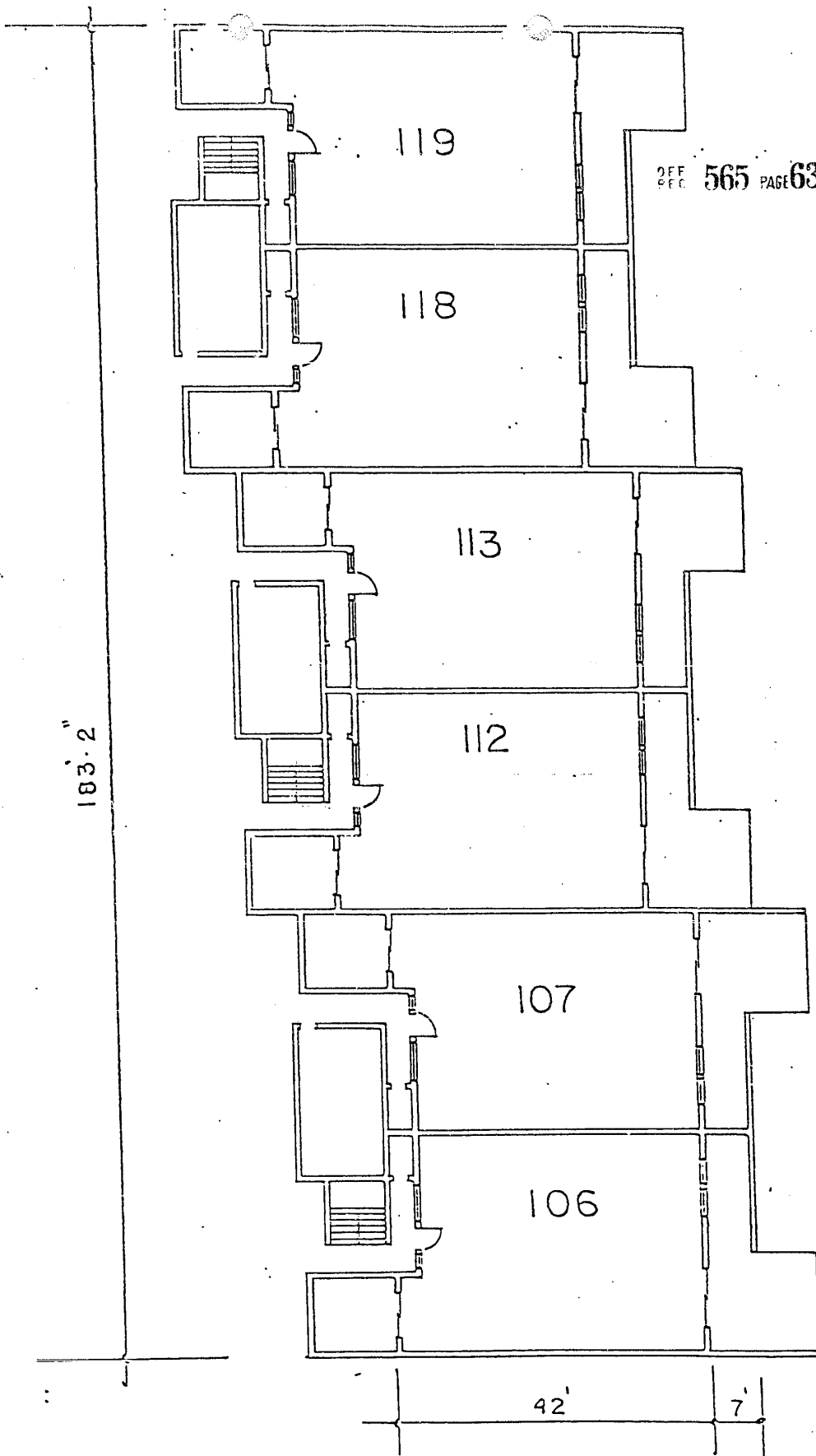

2 FF
2 FC 565 PAGE 632

183' 2"

42'

7'

ELDC G

REF. 565 PAGE 633

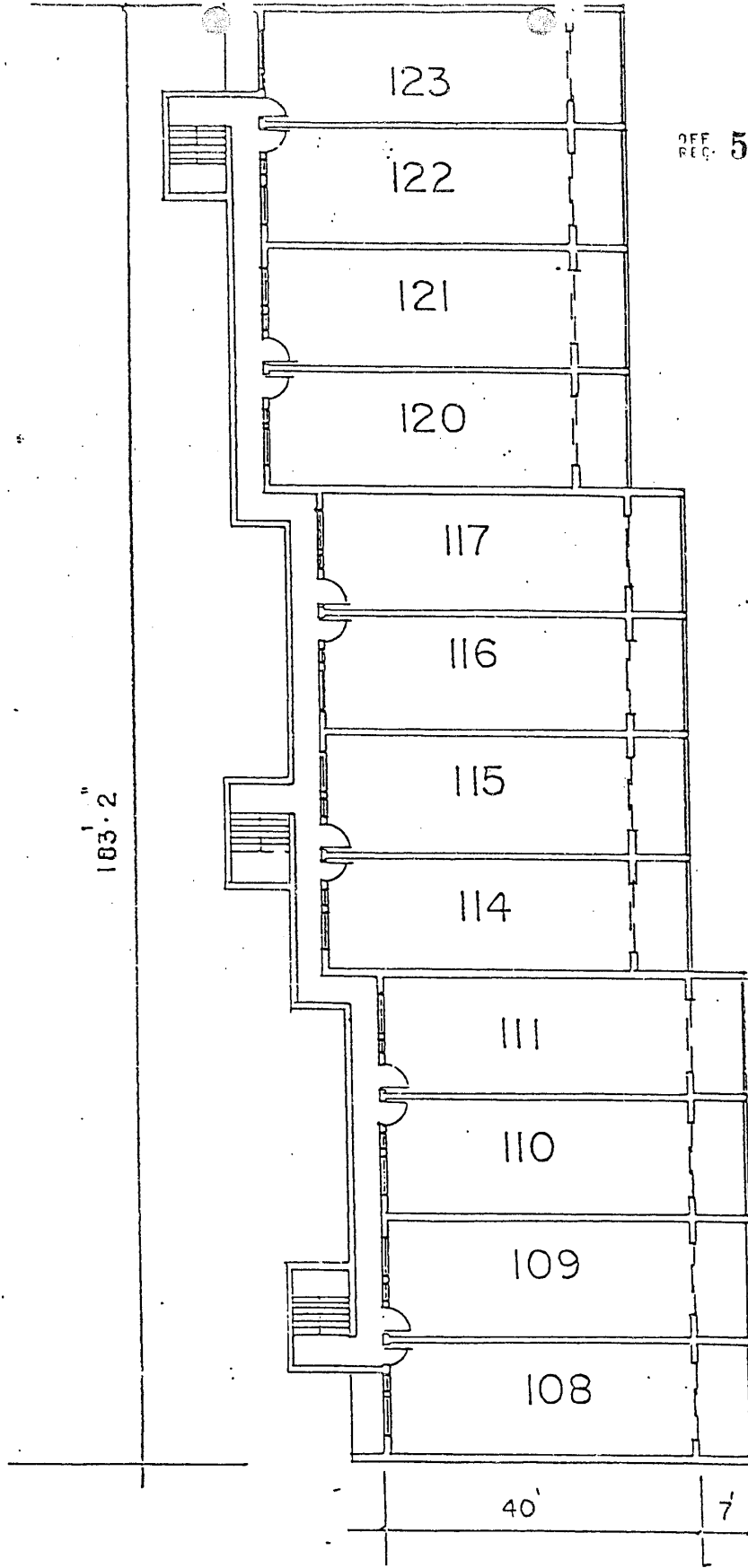

103'-2"

40'

7'

BLDG G

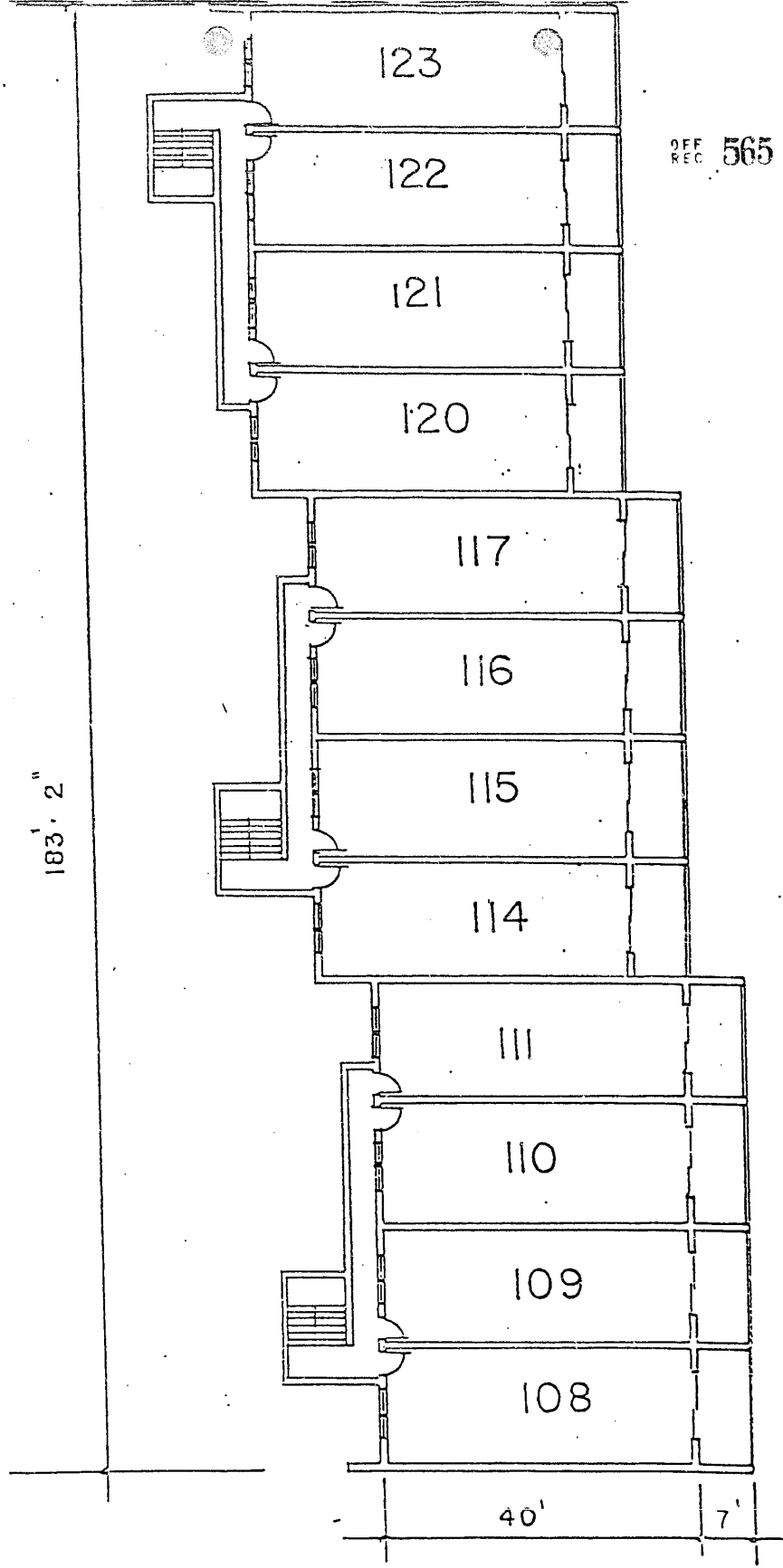

OFF REC 565 PAGE 634

183' 2"

40' 7"

ELDG

3RD FLOOR

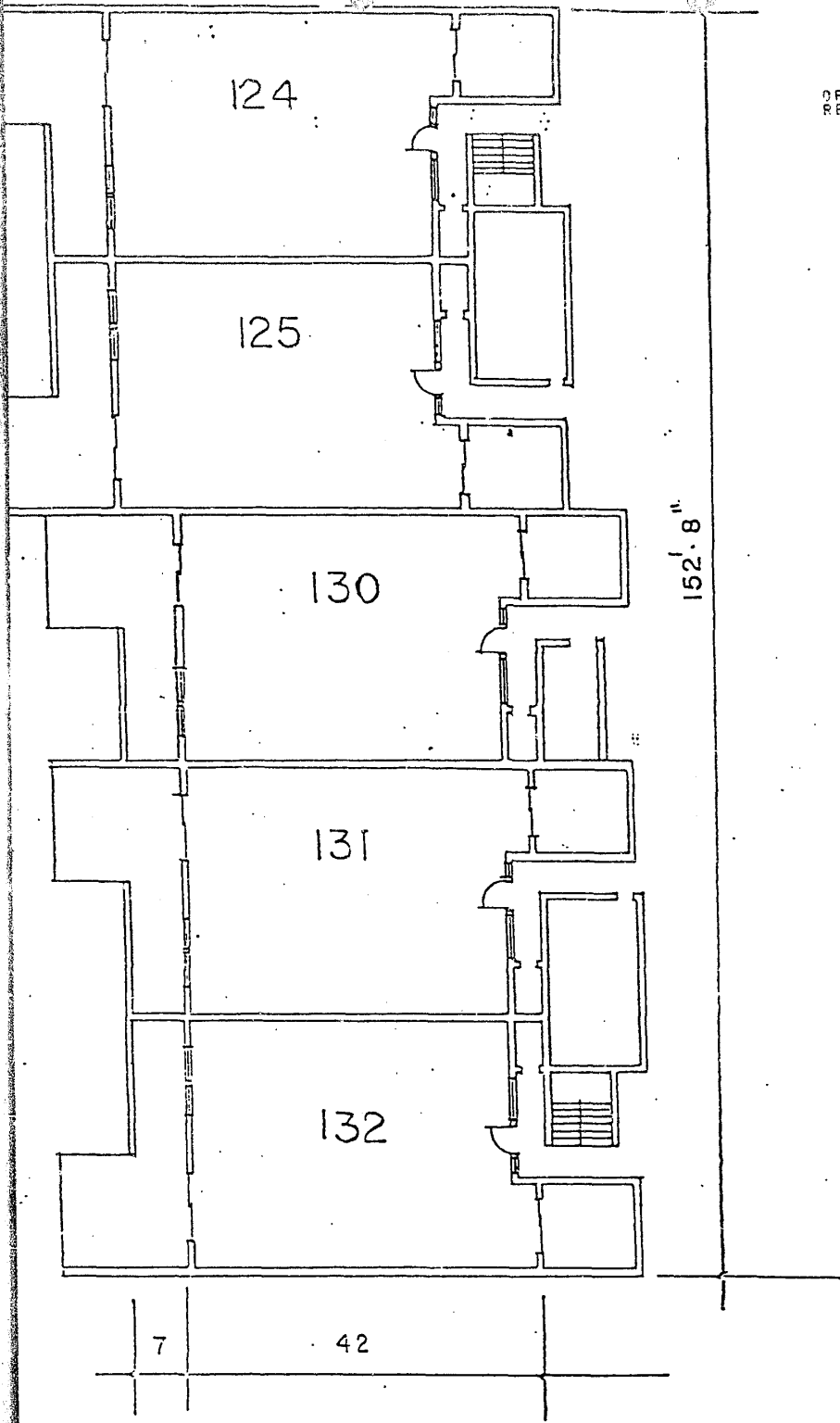

BLDG. "K"

FIRST FLOOR

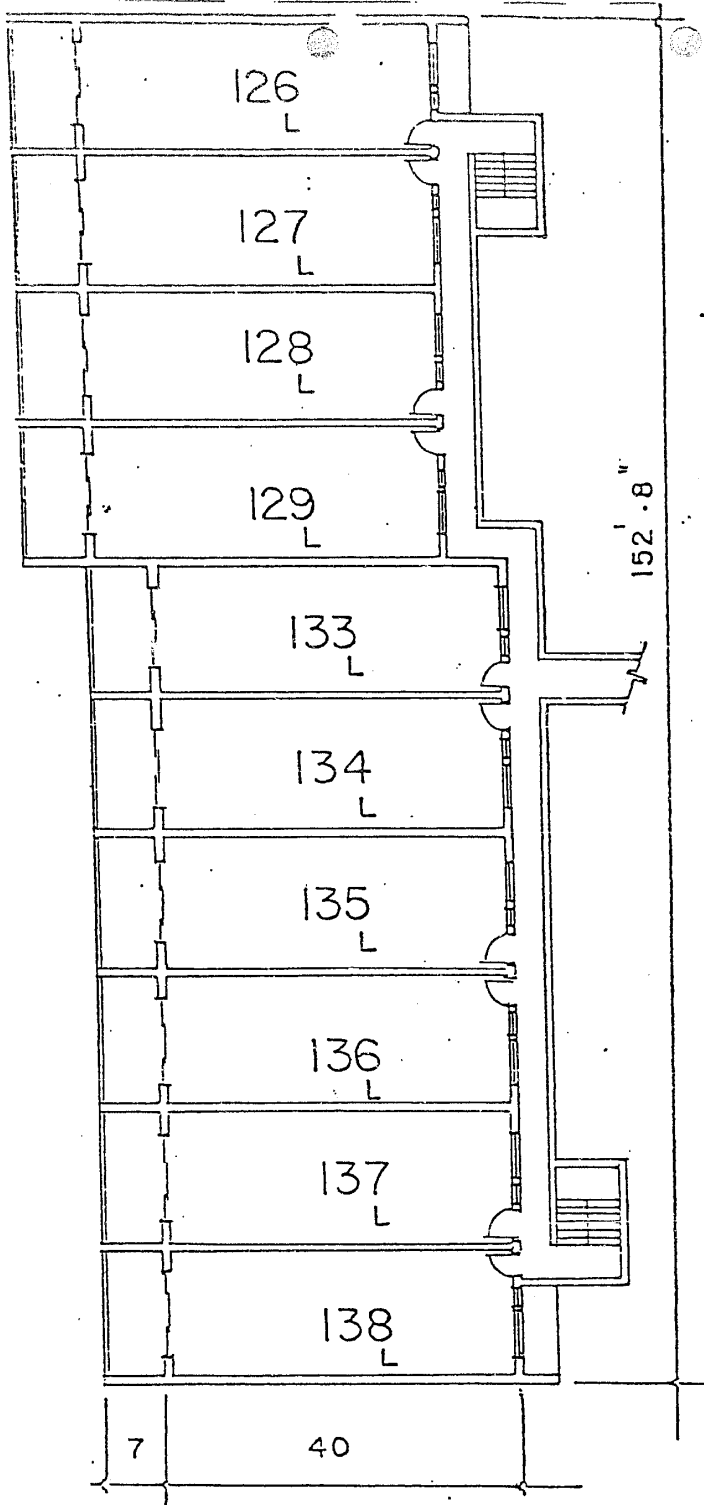

BLDG. "H"

SECOND FLOOR

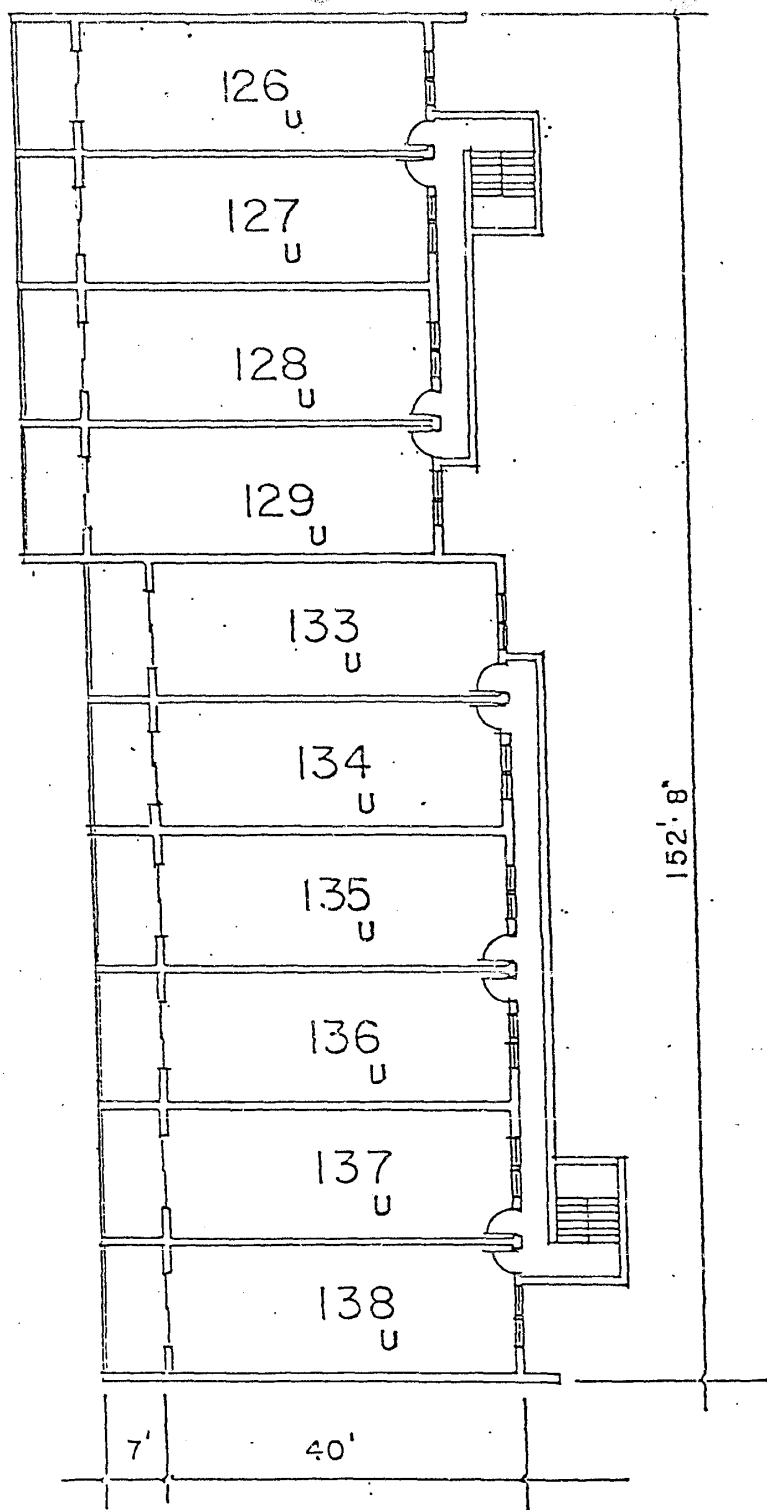

BLDG. "H"

THIRD FLOOR

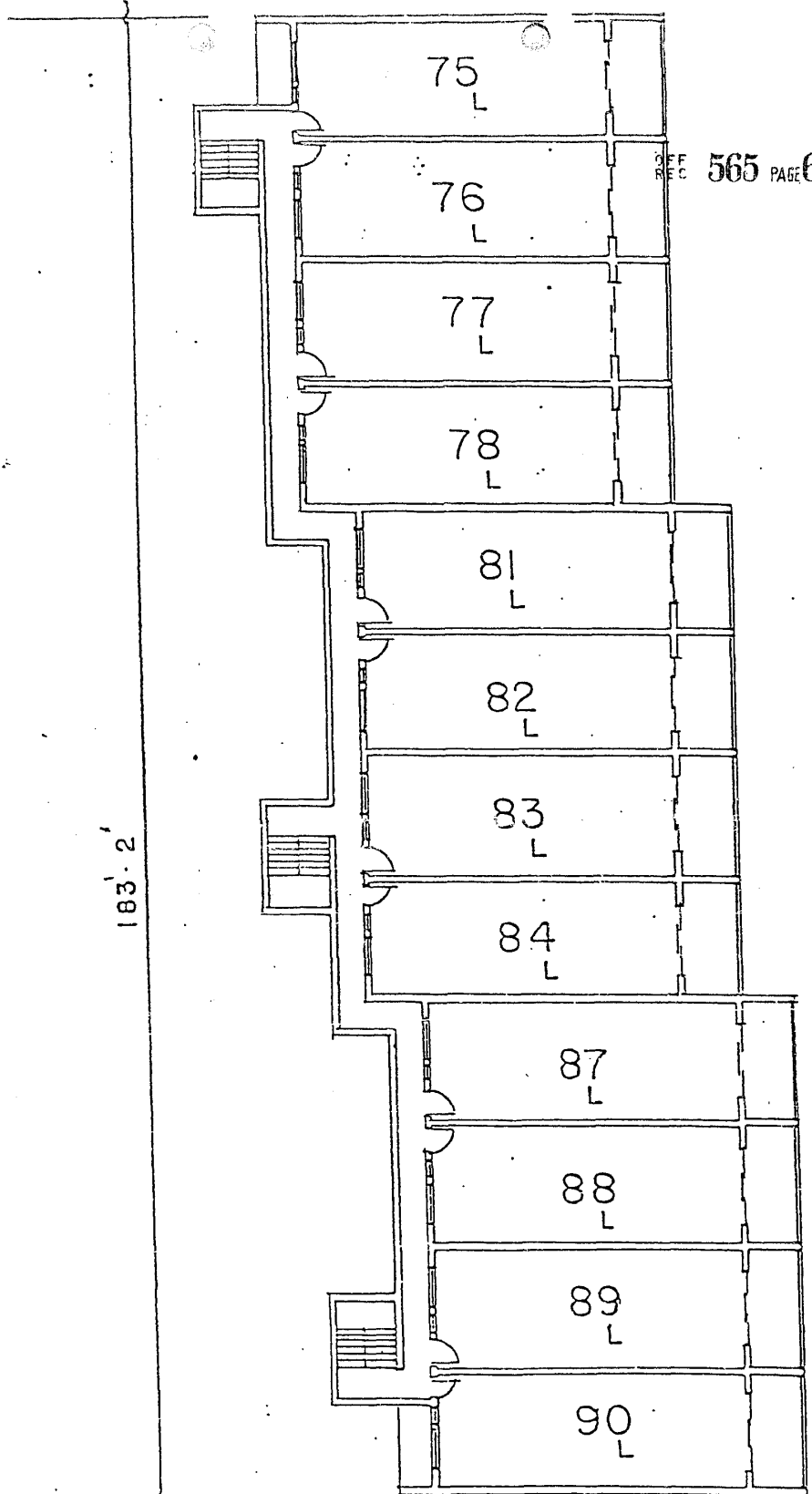

OFF REC 565 PAGE 638

183'-2"

40' 7'

BLDG. "I"

SECOND FLOOR

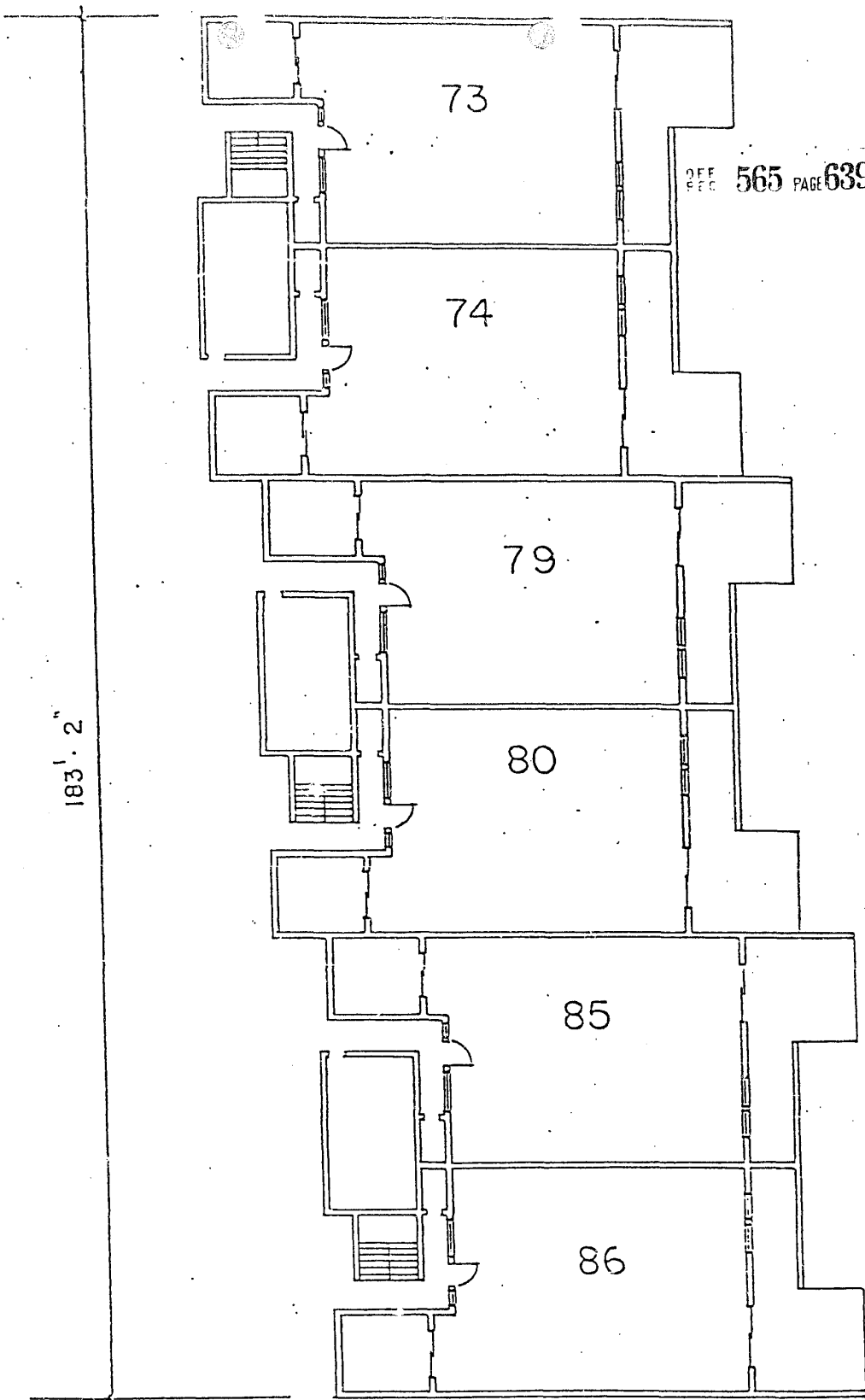

OFF REC 565 PAGE 639

BLDG. "I"

FIRST FLOOR

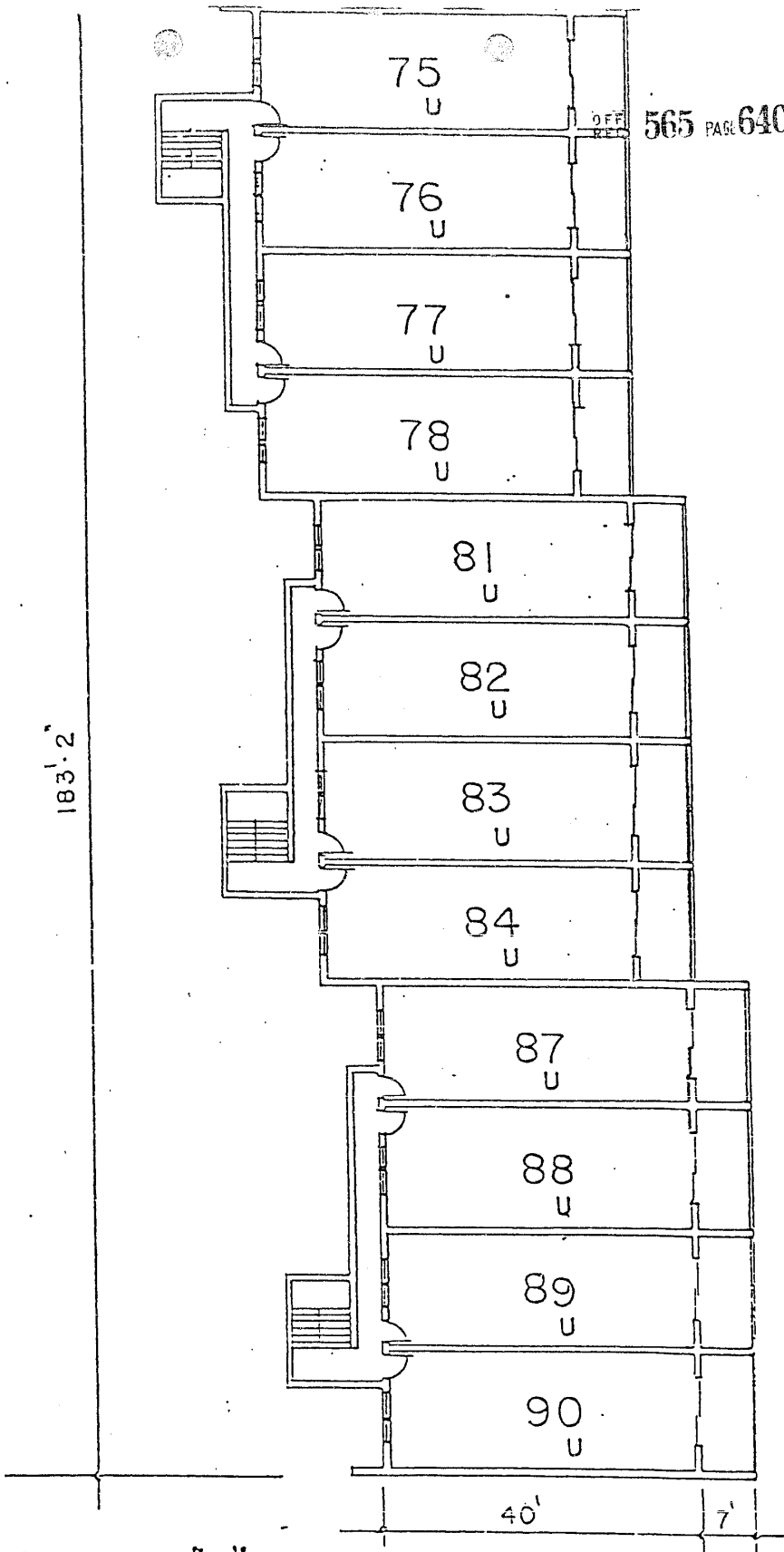

BLDG. "I"

THIRD FLOOR

DEF REC 365 PAGE 641

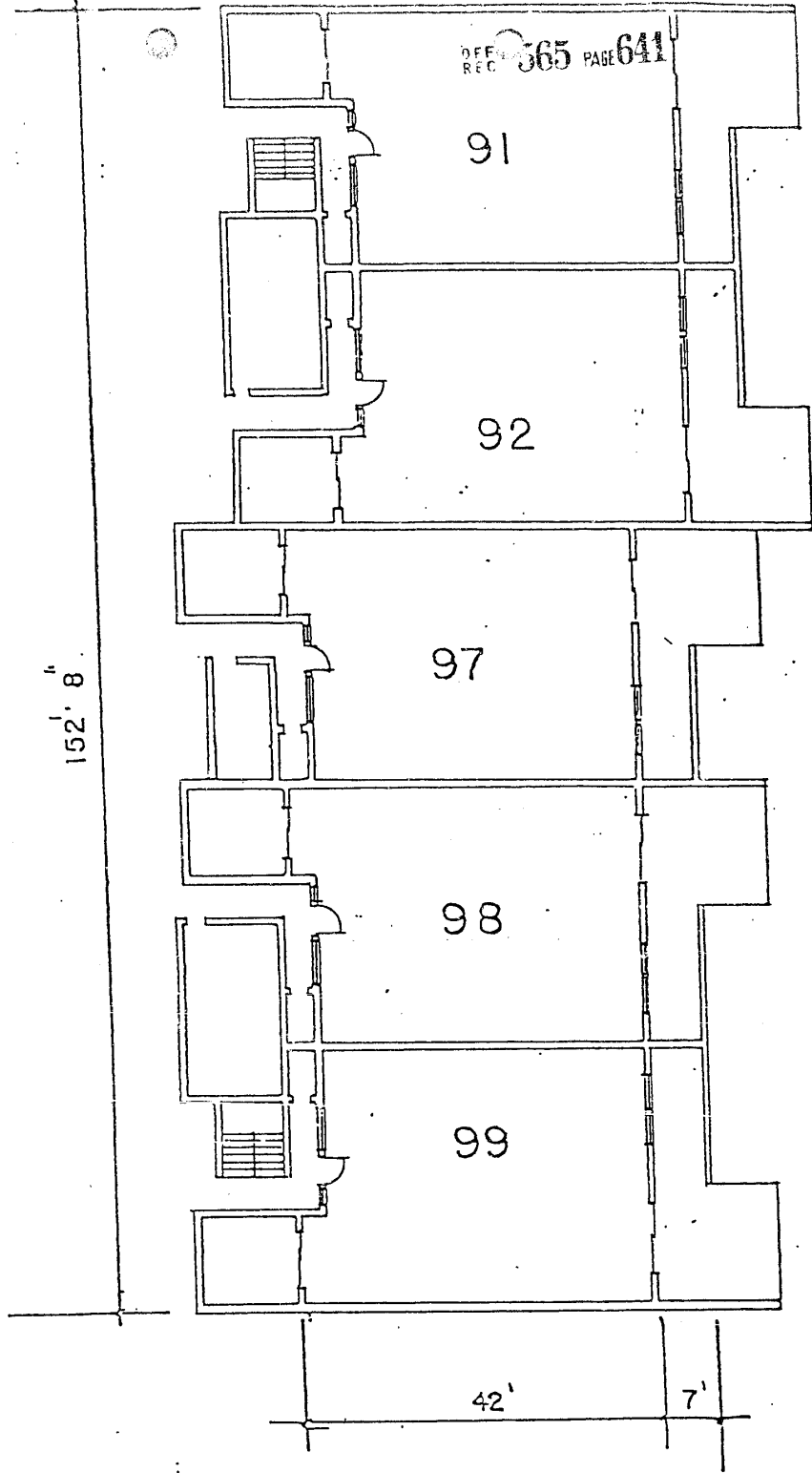

BLDG. "J"

FIRST FLOOR

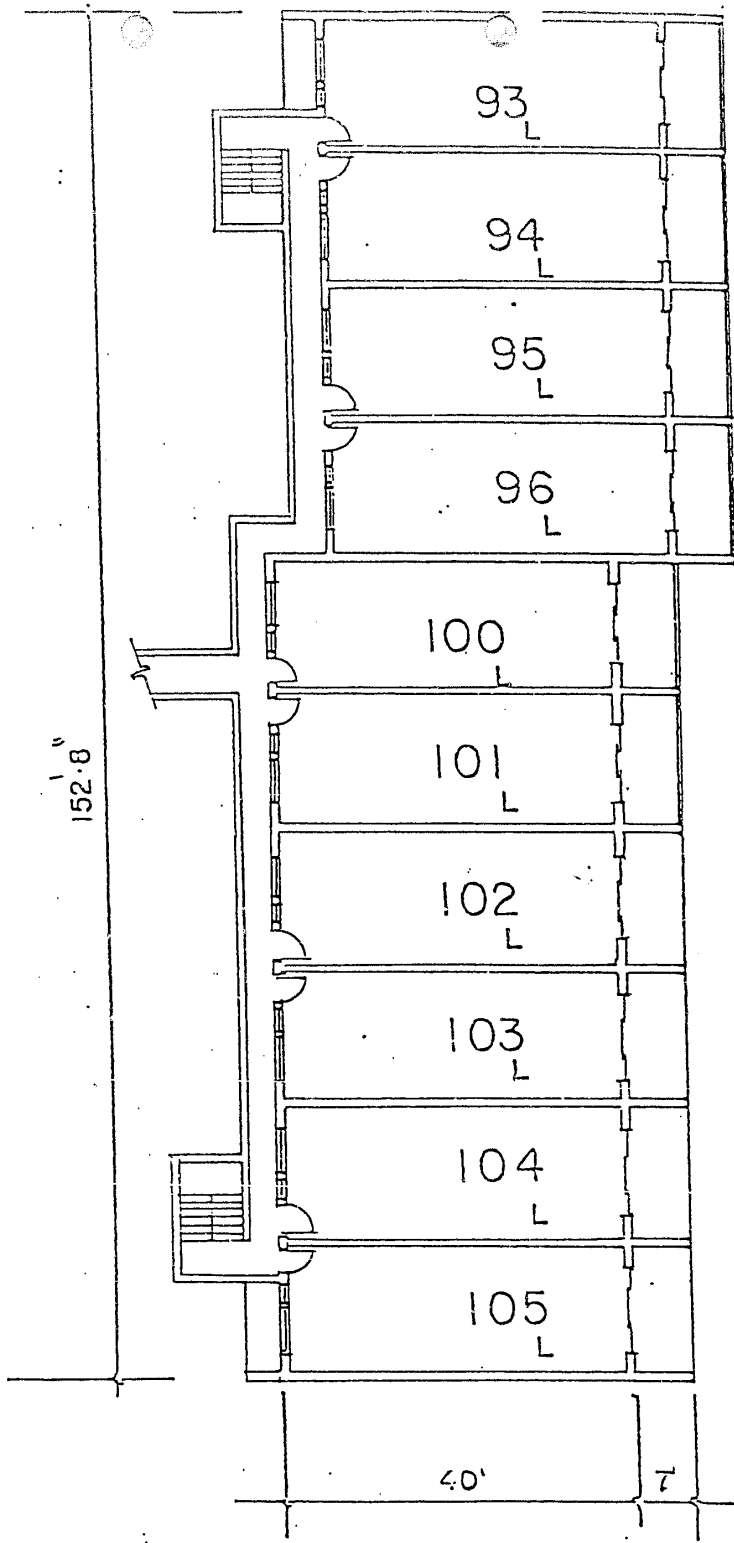

OFF REC 565 PART 642

BLDG. "J"

SECOND FLOOR

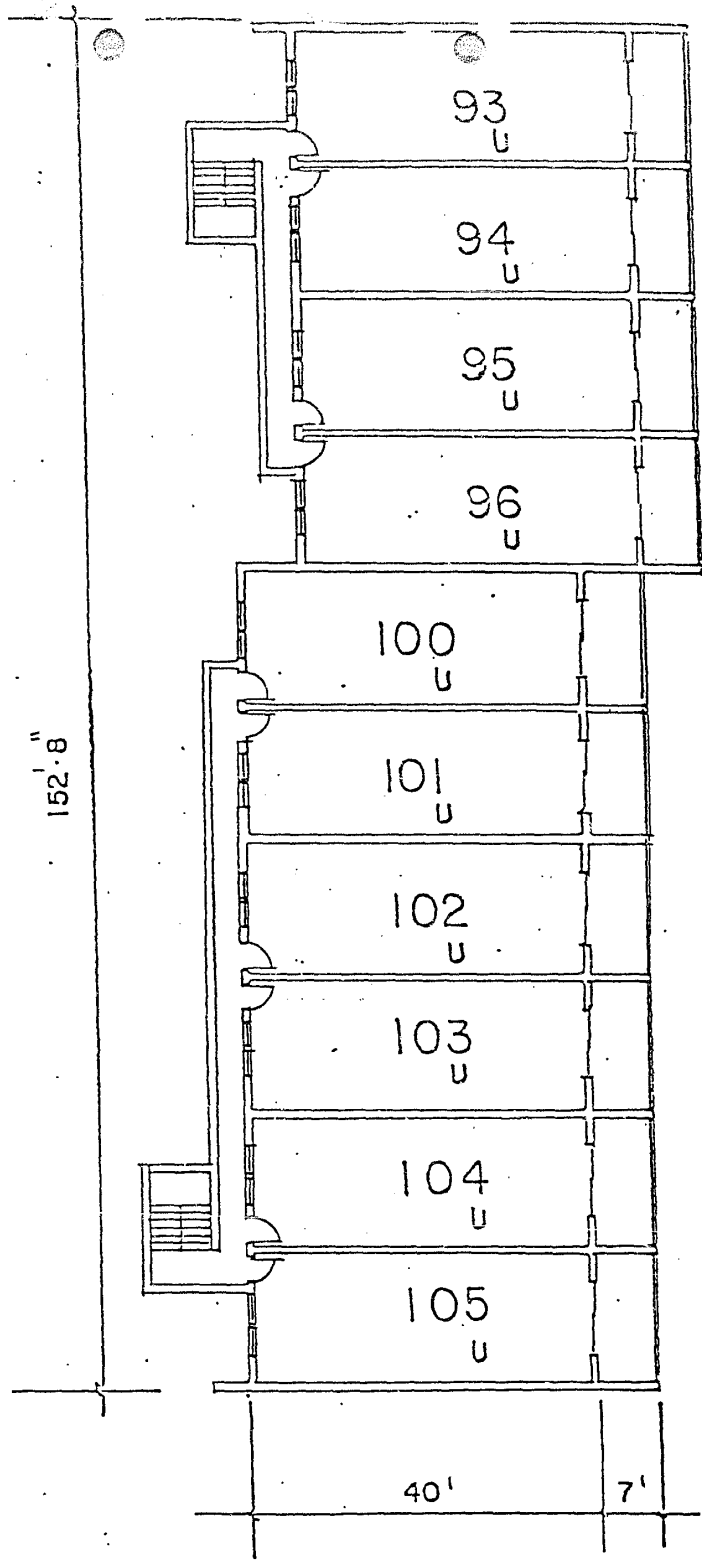

SEE 565 PAGE 643

BLDG. "J"

THIRD FLOOR

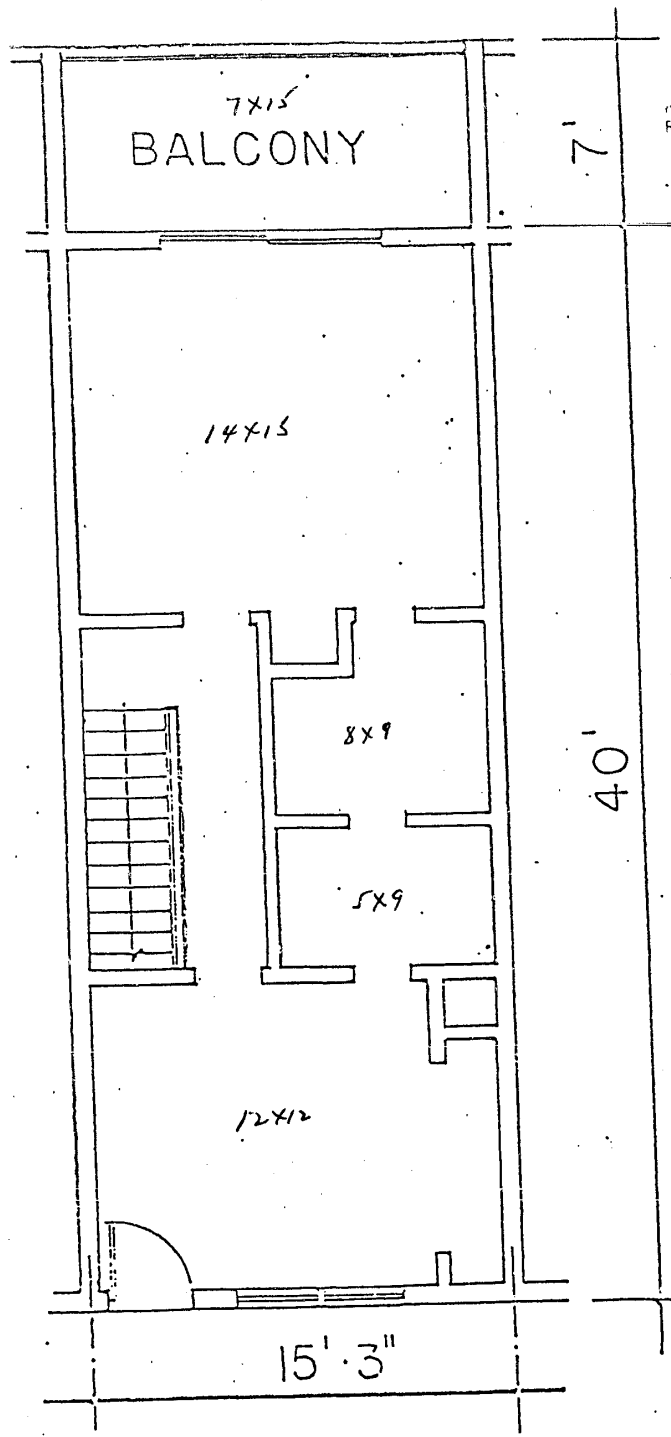

OFF REC 565 PAGE 64

DIMENSIONS SUBJECT TO NORMAL VARIATIONS

TYPICAL UNIT

UPPER (U)

- # 4, 6, 10, 12, 16, 18, 22, 23, 28, 30, 34
 36, 40, 42, 71, 69, 65, 63, 57, 57, 53, 51
 47 45

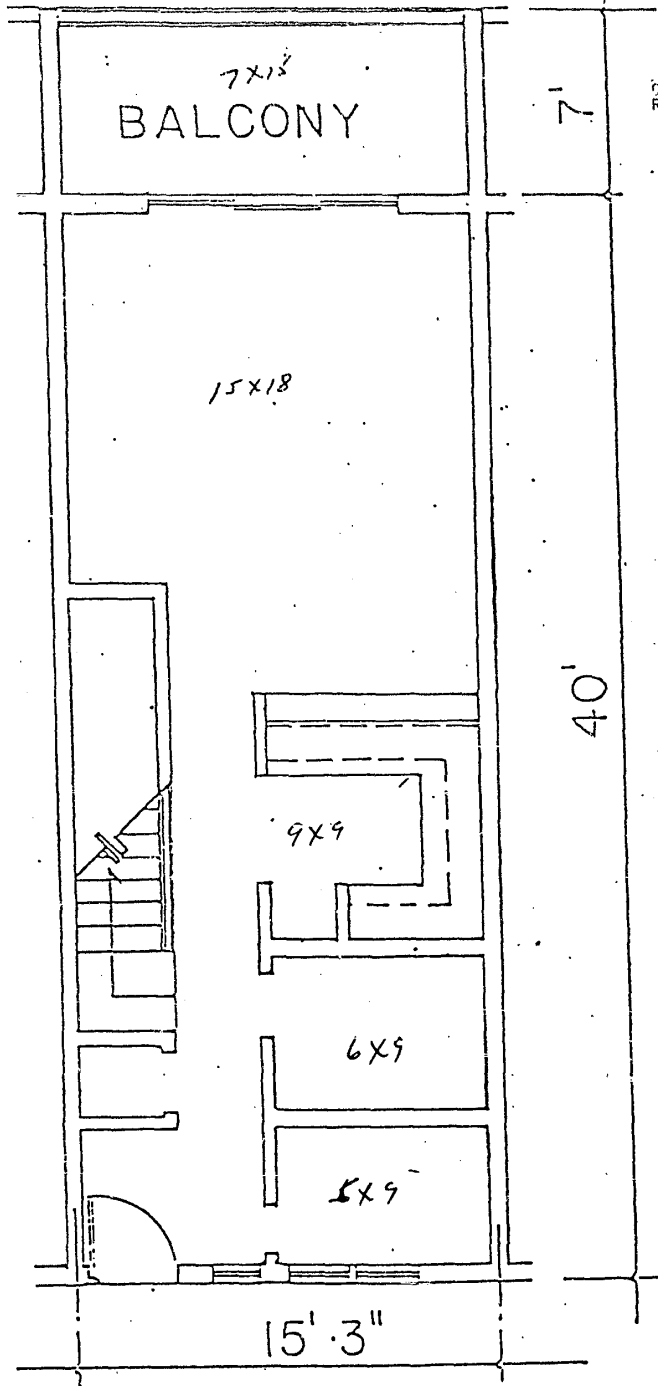

OFF REC 565 PAGE 645

DIMENSIONS SUBJECT TO NORMAL VARIATIONS

TYPICAL UNIT

LOWER (L)

- # 4, 6, 10, 12, 16, 18, 22, 23, 28, 30, 34, 36, 40, 42, 44, 46, 48, 51, 53, 57, 59, 61, 63, 65, 67, 69, 71, 73, 75, 77, 79, 81, 83, 85, 87, 89, 91, 93, 95, 97, 99, 101, 103, 105, 107, 109, 111, 113, 115, 117, 119, 121, 123, 125, 127, 129, 131, 133, 135, 137, 139, 141, 143, 145, 147, 149, 151, 153, 155, 157, 159, 161, 163, 165, 167, 169, 171, 173, 175, 177, 179, 181, 183, 185, 187, 189, 191, 193, 195, 197, 199, 201, 203, 205, 207, 209, 211, 213, 215, 217, 219, 221, 223, 225, 227, 229, 231, 233, 235, 237, 239, 241, 243, 245, 247, 249, 251, 253, 255, 257, 259, 261, 263, 265, 267, 269, 271, 273, 275, 277, 279, 281, 283, 285, 287, 289, 291, 293, 295, 297, 299, 301, 303, 305, 307, 309, 311, 313, 315, 317, 319, 321, 323, 325, 327, 329, 331, 333, 335, 337, 339, 341, 343, 345, 347, 349, 351, 353, 355, 357, 359, 361, 363, 365, 367, 369, 371, 373, 375, 377, 379, 381, 383, 385, 387, 389, 391, 393, 395, 397, 399, 401, 403, 405, 407, 409, 411, 413, 415, 417, 419, 421, 423, 425, 427, 429, 431, 433, 435, 437, 439, 441, 443, 445, 447, 449, 451, 453, 455, 457, 459, 461, 463, 465, 467, 469, 471, 473, 475, 477, 479, 481, 483, 485, 487, 489, 491, 493, 495, 497, 499, 501, 503, 505, 507, 509, 511, 513, 515, 517, 519, 521, 523, 525, 527, 529, 531, 533, 535, 537, 539, 541, 543, 545, 547, 549, 551, 553, 555, 557, 559, 561, 563, 565, 567, 569, 571, 573, 575, 577, 579, 581, 583, 585, 587, 589, 591, 593, 595, 597, 599, 601, 603, 605, 607, 609, 611, 613, 615, 617, 619, 621, 623, 625, 627, 629, 631, 633, 635, 637, 639, 641, 643, 645

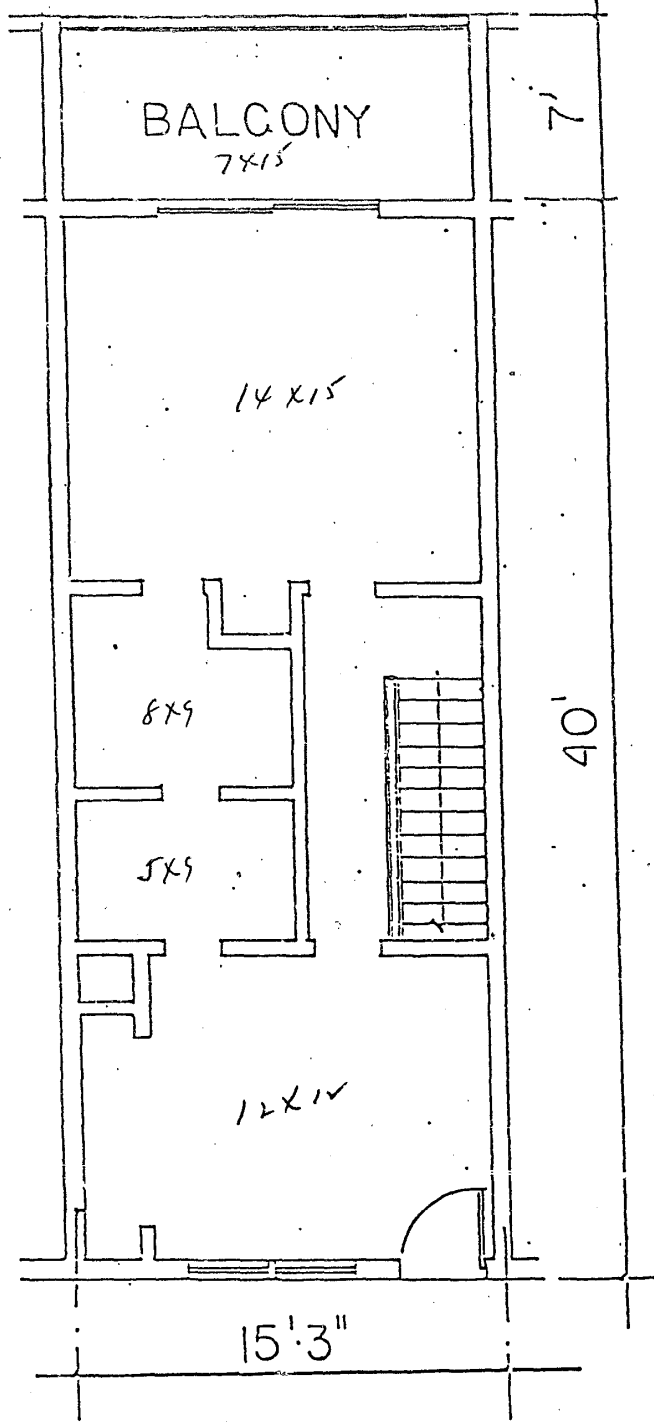

DIMENSIONS SUBJECT TO NORMAL VARIATIONS

TYPICAL UNIT
UPPER (U)

- # 3, 5, 7, 11, 15, 17, 21, 23, 27, 29, 33, 35, 37, 41, 42, 46, 48, 50, 52, 54, 56, 58, 60, 62, 64, 66, 68, 70, 72, 74, 76, 78, 80, 82, 84, 86, 88, 90, 92, 94, 96, 98, 100

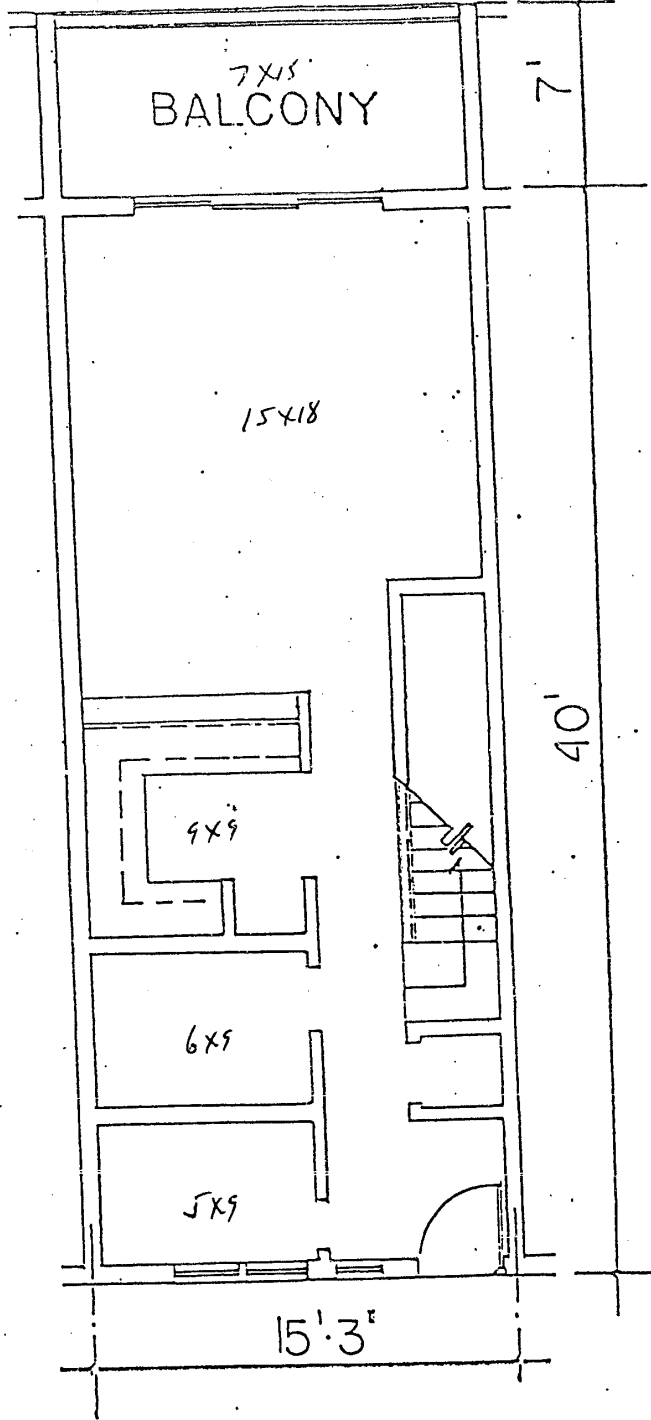

DIMENSIONS SUBJECT TO NORMAL VARIATIONS

TYPICAL UNIT
LOWER (L)

- 3, 5, 9, 11, 15, 17, 21, 23, 27, 27, 33, 35, 37, 41
- 72, 70, 66, 64, 60, 58, 54, 52, 48, 46

30' 5"

REF 565 PAGE 648

17 x 30

PATIO

12 x 15

15 x 18

5 x 9

5 x 9

9 x 9

12 x 11

11 x 13

DIMENSIONS SUBJECT TO NORMAL VARIATIONS

PATIO

9 x 11

TYPICAL UNIT

30' 5"

REF REC 565 PAGE 649

PATIO

17x30

7'

~~25x8~~

~~12x15~~

5x9

6x9

9x9

40'

11x13

12x11

2'

9x11
PATIO

TYPICAL UNIT

DIMENSIONS SUBJECT TO NORMAL VARIATIONS

1 7 13 19 25 31 37

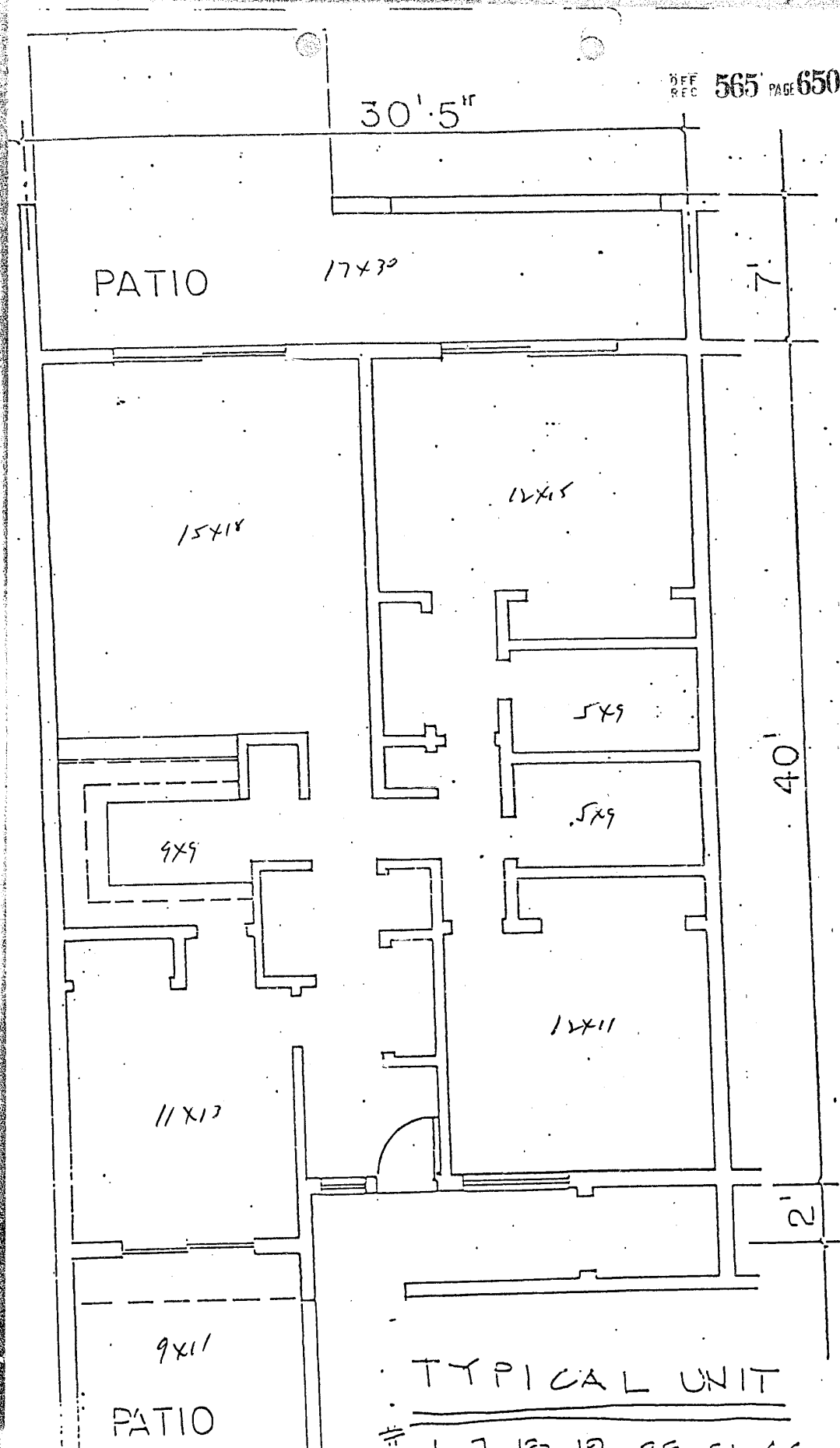

DIMENSIONS SUBJECT TO NORMAL VARIATIONS

TYPICAL UNIT

- # 1 7 13 19 25 31 37

30' 5"

PATIO

17x70

7'

15x18

12x15

5x9

4x9

5x9

40'

11x12

12x11

2'

9x14

PATIO

TYPICAL UNIT

1 7 13 19 25 31 37

DIMENSIONS SUBJECT TO NORMAL VARIATIONS

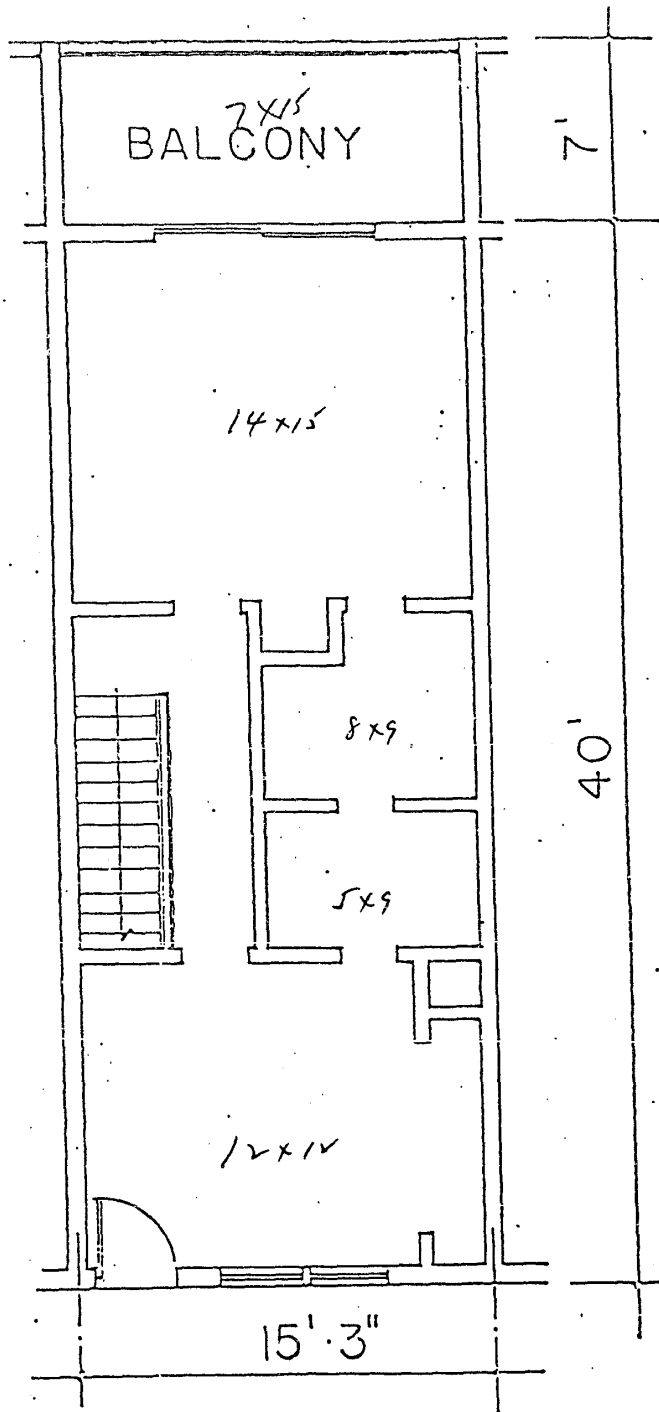

DIMENSIONS SUBJECT TO NORMAL VARIATIONS

TYPICAL UNIT
UPPER (U)

#

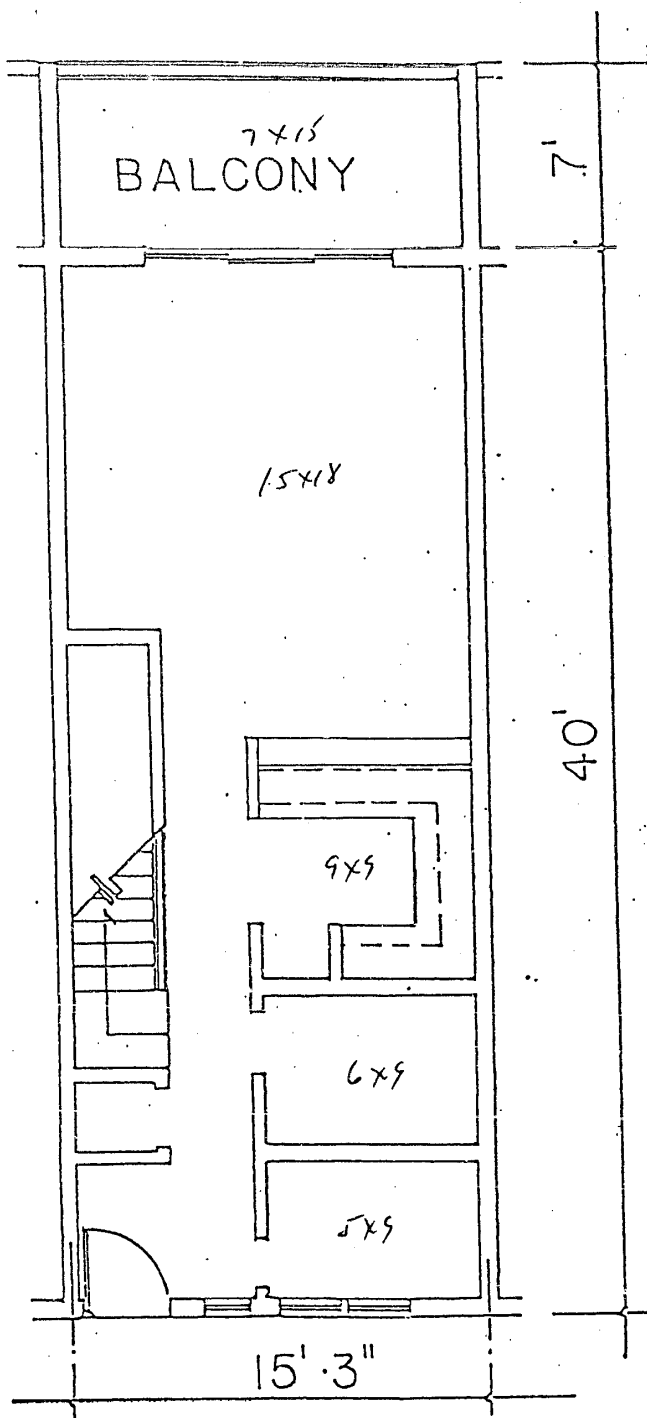

DIMENSIONS SUBJECT TO NORMAL VARIATIONS

TYPICAL UNIT
LOWER (L)

#

76, 78, 82, 84, 88, 90, 94, 96, 101, 103, 105

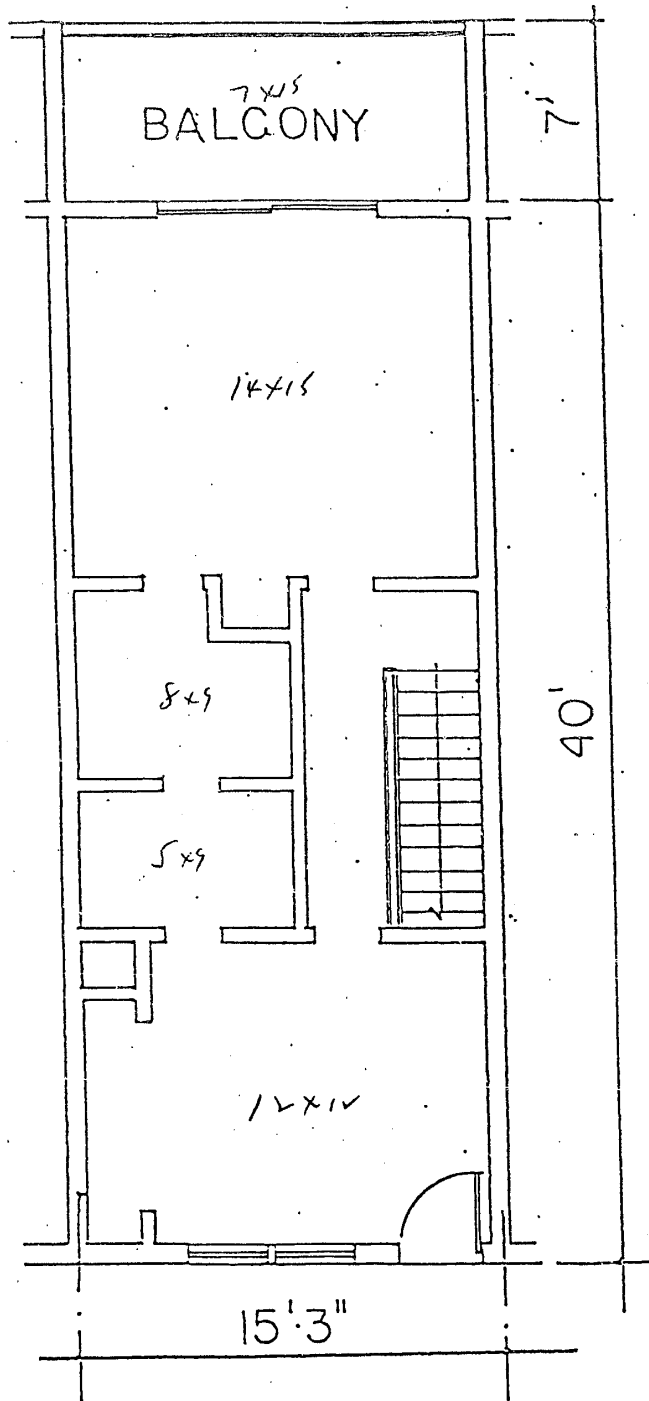

DIMENSIONS SUBJECT TO NORMAL VARIATIONS

TYPICAL UNIT
UPPER (U)

#

- 75, 77, 81, 83, 87, 89, 93, 95, 100, 102,
- 104, 123, 121, 117, 115, 111, 109, 138, 136, 134,

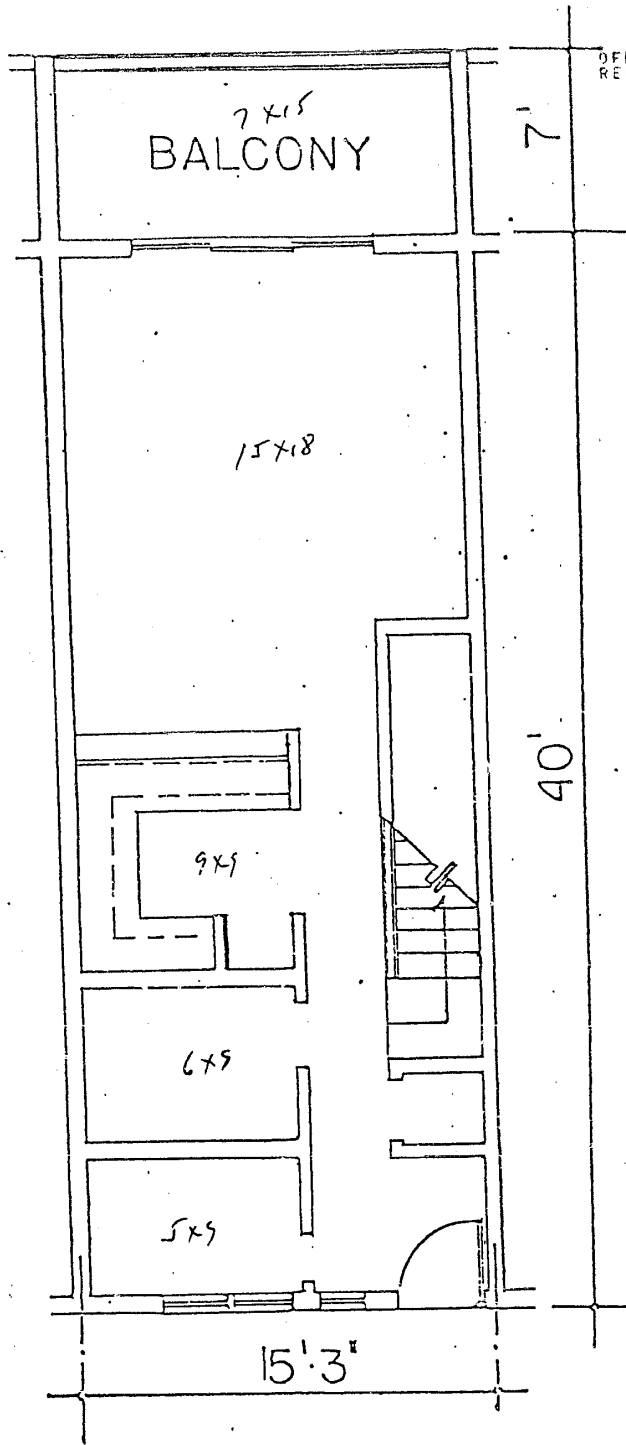

DIMENSIONS SUBJECT TO NORMAL VARIATIONS

TYPICAL UNIT
LOWER (L)

11.

30' 5"

17 x 30 PATIO

DIMENSIONS SUBJECT TO NORMAL VARIATIONS

12 x 15

15 x 18

5 x 9

5 x 9

9 x 9

12 x 11

11 x 13

PATIO

9 x 11

TYPICAL UNIT

11

30' 5"

PATIO

17x30

7'

15x18
~~15x18~~

12x15
~~15x15~~

5x9

5x9

40'

9x9

12x11

11x13

2'

9x11
PATIO

TYPICAL UNIT

#

DIMENSIONS SUBJECT TO NORMAL VARIATIONS

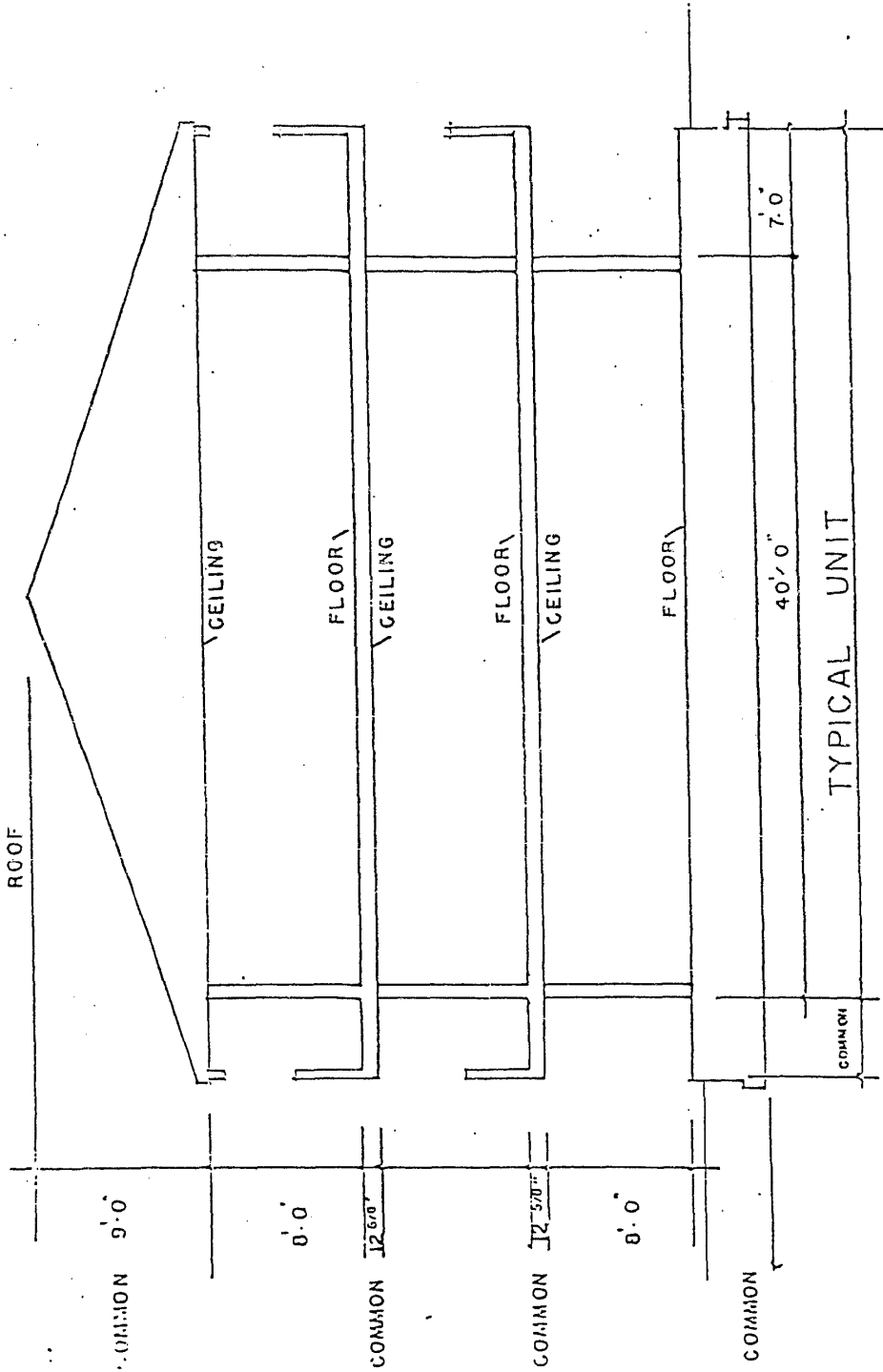

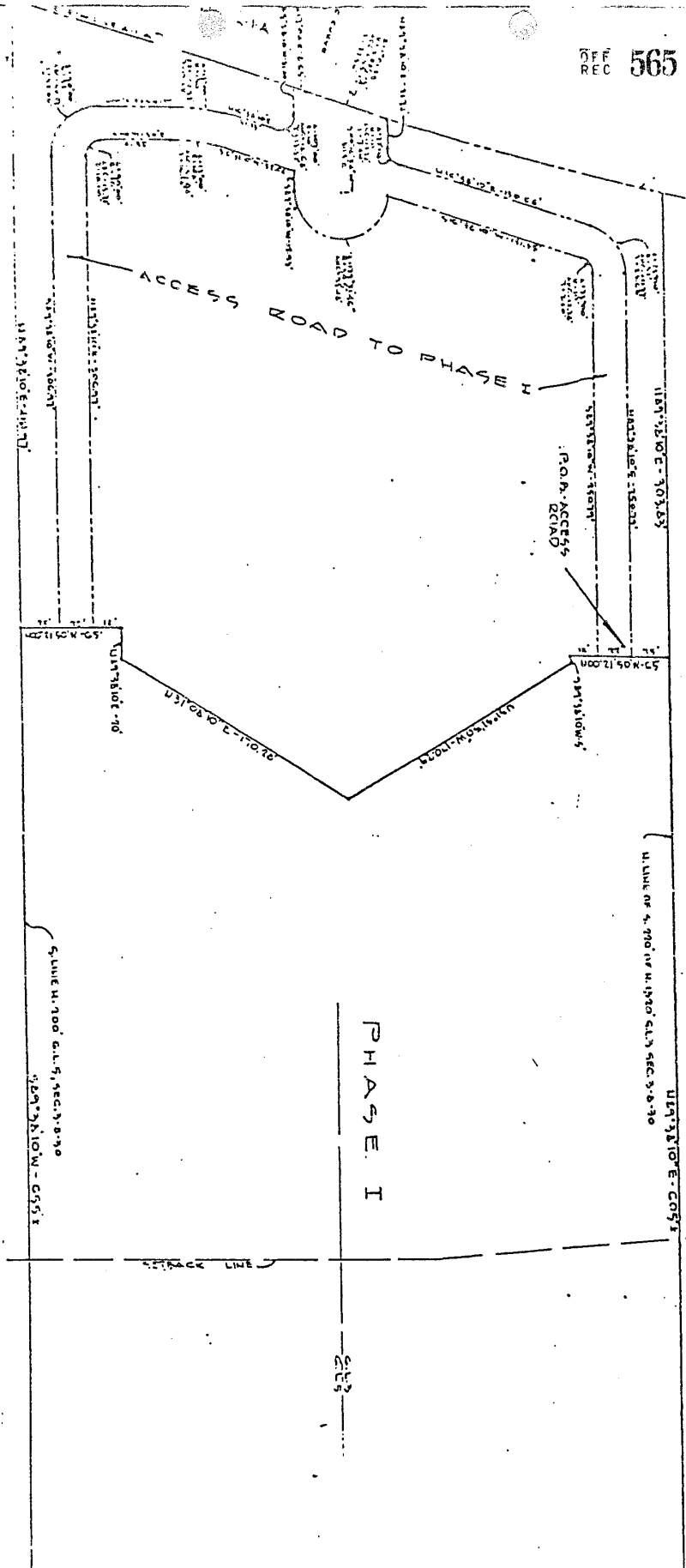

Scale 1" = 100'

North Arrow

5/11/70

100'

CONSENT OF MORTGAGEE

KNOW ALL MEN BY THESE PRESENTS, that:

FIDELITY FEDERAL SAVINGS & LOAN ASSOCIATION (Jacksonville, Florida)

("Mortgagee"), the owner and holder of a mortgage from OCEAN VILLAS AT ST. AUGUSTINE BEACH CONDOMINIUM ASSOCIATION, INC. in the original amount of \$4,500,000.00** recorded in Official Records Vol. 544, page 796, current public records of St. Johns County, Florida, hereby consents to the Declaration of Condominium of OCEAN VILLAS CONDOMINIUM, dated _____, and the recording of such Declaration in the public records of St. Johns County, Florida, and the Mortgagee agrees that the lien of its mortgage shall hereafter be upon all of the Units of OCEAN VILLAS CONDOMINIUM, according to the Declaration of Condominium together with all of the appurtenances thereto, including but not limited to all of the undivided shares in the Common Elements.

DATED this 27th day of October, 1982

FILED AND RECORDED IN PUBLIC RECORDS OF JOHN'S COUNTY, FLA. 1982 DEC 20 PM 12:23

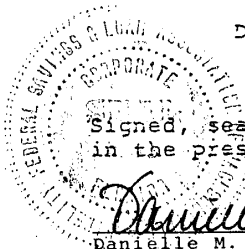

Signed, sealed and delivered in the presence of:

Danielle M. French
Danielle M. French, Secretary
Lina J. Griffin

Paul [unclear]
CLERK OF DISTRICT COURT

FIDELITY FEDERAL SAVINGS & LOAN ASSOCIATION OF JACKSONVILLE

By: *Robert A. York*
Robert A. York, Executive Vice President

EXHIBIT X