



# Low-Level Access

888-569-4050  
low-levelaccess.com



**ECOLIFT 1100**  
11' Non-Powered, Powered Access

**ECOLIFT 1300**  
13' Non-Powered, Powered Access



**BATTERY FREE  
POWER FREE  
OIL FREE  
EASY! FAST! SAFE!  
AWARD WINNING**



1. STEP IN



2. TURN THE HANDLE



3. 11' WORKING HEIGHT IN 11 SECONDS

**CALL TODAY FOR PRICE AND AVAILABILITY**



Can be specified with ATEX approval for Zones 1 and 21.

# ECOLIFT 1100

11' Non-Powered, Powered Access

## OPERATING SPECIFICATIONS

Working Dimensions	Standard	Wind Rated
Maximum working height:	10 ft 11 in	
Maximum platform height:	4'11"	
Basket dimensions:	28" x 24"	
Working footprint:	39 in x 26.5 in	<b>43 in x 43 in</b>
Safe working load:	330 lb (1 person + tools)	
Maximum manual force:	200 N	
Maximum gradient for operation:	0 degrees	<b>3°</b>
Maximum wind force:	Internal use only, 0 (zero) mph	<b>Internal/ External Use. 28mph. 429 lb 429 lb</b>
Maximum wheel force:	275 lb	
Maximum castor point load:	275 lb	
Sound pressure level:	Less than 70DbA	

Closed Dimensions	Standard	Wind Rated
Length:	3 ft 3 in	<b>3 ft 7 in</b>
Width:	2 ft 4 in	<b>3 ft 7 in</b>
Height:	5 ft 1 in	<b>5 ft 1 in</b>
Weight:	396 lb	<b>530 lb</b>

Lift Cycles	Standard	Wind Rated
	Unlimited	Unlimited



10' 11"

4' 11"



From here to full working height in 11 seconds



**WIND RATED**  
Available as an option to the standard machine, Pecolift Wind Rated is operable on gradients up to 3° and in winds up to 28mph.

# ECOLIFT 1300

13' Non-Powered, Powered Access

## OPERATING SPECIFICATIONS

Working Dimensions	Standard	Wind Rated
Maximum working height:	13 ft 3 in	
Maximum platform height:	7 ft 3 in	
Basket dimensions:	33 x 25 in	
Working footprint:	4 ft 2 in x 29 in	<b>50 in x 38 in</b>
Safe working load:	330 lb (1 person + tools)	
Maximum manual force:	200 N	
Maximum gradient for operation:	0 degrees	<b>3°</b>
Maximum wind force:	Internal use only, 0 (zero) mph	<b>Internal/ External Use. 28mph. 540 lb 540 lb (2.4kN)</b>
Maximum wheel force:	515 lb	
Maximum castor point load:	515 lb (2.29 kN)	
Sound pressure level:	Less than 70DbA	

Closed Dimensions	Standard	Wind Rated
Length:	4 ft 2 in	<b>4 ft 2 in</b>
Width:	2 ft 4 in	<b>3 ft 2 in</b>
Height:	6 ft 5 in	<b>6 ft 5 in</b>
Weight:	672 lb	<b>672 lb</b>

Lift Cycles	Standard	Wind Rated
	Unlimited	Unlimited



13' 3"

7' 3"

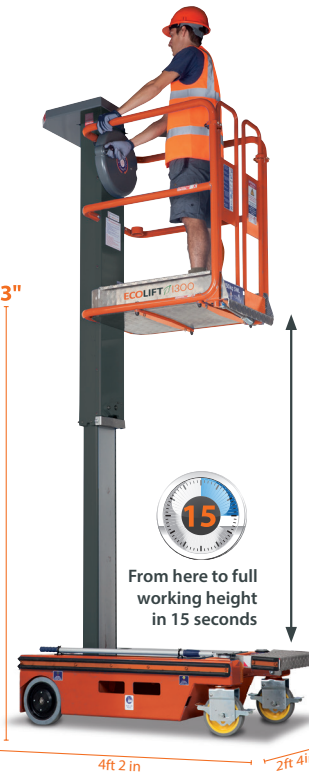

From here to full working height in 15 seconds



**WIND RATED**  
Available as an option to the standard machine, Ecolift Wind Rated is operable on gradients up to 3° and in winds up to 28mph.

# Work Smart ...IT PAYS TO SPECIFY POWER TOWERS

Power Towers' products offer proven productivity gains - up to 8 times faster than traditional methods of access using podiums and towers.



Non-powered Powered Access! ...  
A major step change in low-level access.

It's so easy, fast and efficient to use, it's intuitive. Just step in and turn the handle! And you don't need power; no batteries to charge or mains power consumption. We call it 'non-powered powered access!'<sup>©</sup>

Gone are the days of climbing steps or podiums, no more slips, trips or having to balance!

Stop wherever you want up to 13'3" working height.

You're always safe, fully guarded from the ground up. And its low maintenance, in fact it's virtually maintenance free, it's so simple!



- Step into the platform, no climbing.
- Intuitive to operate - turn handle to elevate. Patented\* lift mechanism, no power required.
- 'Auto-lok' brake on elevation.
- Lightweight, easy to manoeuvre.
- Small footprint
- Unlimited lift cycles, can be used 24/7.
- Robust design for years of trouble free service.
- Minimal operational costs, virtually maintenance free.

## eco compliant

Power Towers is committed to eco friendly manufacture. Our Eco range of products are hydraulic oil and battery free, and with no need to charge, have no energy consumption. They are an Eco friendly solution to your Powered Access needs.

This brochure and associated data is intended as a guide only and as such is not legally binding, nor does it form part of any contract. All dimensions are approximate. Power Towers' products are 100% designed and manufactured in the UK. \*Patent applied for.

 **Low-Level Access**  
888-569-4050  
[low-levelaccess.com](http://low-levelaccess.com)

CALL TODAY FOR PRICE AND AVAILABILITY

