



An Oshkosh Corporation Company

---

# ***Operation and Safety Manual***

*Original Instructions - Keep this manual with the machine at all times.*

***Models***

***EcoLift50***

***EcoLift70***



***ANSI***

---

***P/N - 3121740***

*May 26, 2016*



## **FOREWORD**

This manual is a very important tool! Keep it with the machine at all times.

The purpose of this manual is to provide owners, users, operators, lessors, and lessees with the precautions and operating procedures essential for the safe and proper machine operation for its intended purpose.

Due to continuous product improvements, JLG Industries, Inc. reserves the right to make specification changes without prior notification. Contact JLG Industries, Inc. for updated information.

## **SAFETY ALERT SYMBOLS AND SAFETY SIGNAL WORDS**



This is the Safety Alert Symbol. It is used to alert you to the potential personal injury hazards. Obey all safety messages that follow this symbol to avoid possible injury or death

### **⚠ DANGER**

INDICATES AN IMMINENTLY HAZARDOUS SITUATION. IF NOT AVOIDED, WILL RESULT IN SERIOUS INJURY OR DEATH. THIS DECAL WILL HAVE A RED BACKGROUND.

### **⚠ WARNING**

INDICATES A POTENTIALITY HAZARDOUS SITUATION. IF NOT AVOIDED, COULD RESULT IN SERIOUS INJURY OR DEATH. THIS DECAL WILL HAVE AN ORANGE BACKGROUND.

### **⚠ CAUTION**

INDICATES A POTENTIALITY HAZARDOUS SITUATION. IF NOT AVOIDED, MAY RESULT IN MINOR OR MODERATE INJURY. IT MAY ALSO ALERT AGAINST UNSAFE PRACTICES. THIS DECAL WILL HAVE A YELLOW BACKGROUND.

### **NOTICE**

INDICATES INFORMATION OR A COMPANY POLICY THAT RELATES DIRECTLY OR INDIRECTLY TO THE SAFETY OF PERSONNEL OR PROTECTION OF PROPERTY.

### **WARNING**

**THIS PRODUCT MUST COMPLY WITH ALL SAFETY RELATED BULLETINS. CONTACT JLG INDUSTRIES, INC. OR THE LOCAL AUTHORIZED JLG REPRESENTATIVE FOR INFORMATION REGARDING SAFETY RELATED BULLETINS WHICH MAY HAVE BEEN ISSUED FOR THIS PRODUCT.**

### **NOTICE**

**JLG INDUSTRIES, INC. SENDS SAFETY RELATED BULLETINS TO THE OWNER OF RECORD OF THIS MACHINE. CONTACT JLG INDUSTRIES, INC. TO ENSURE THAT THE CURRENT OWNER RECORDS ARE UPDATED AND ACCURATE.**

### **NOTICE**

**JLG INDUSTRIES, INC. MUST BE NOTIFIED IMMEDIATELY IN ALL INSTANCES WHERE JLG PRODUCTS HAVE BEEN INVOLVED IN AN ACCIDENT INVOLVING BODILY INJURY OR DEATH OF PERSONNEL OR WHEN SUBSTANTIAL DAMAGE HAS OCCURRED TO PERSONAL PROPERTY OR THE JLG PRODUCT.**

### **For :**

- Accident Reporting
- Product Safety Publications
- Current Owner Updates
- Questions Regarding Product Safety
- Standards and Regulations Compliance Information
- Questions Regarding Special Product Applications
- Questions Regarding Product Modifications

### **Contact:**

Product Safety and Reliability Department  
JLG Industries, Inc.  
1 JLG Drive  
McConnellsburg, PA 17233

or Your Local JLG Office  
(See addresses on manual rear cover)

### **In USA:**

Toll Free: 877-JLG-SAFE (877-554-7233)

### **Outside USA:**

Phone: 717-485-5161  
E-mail: [ProductSafety@JLG.com](mailto:ProductSafety@JLG.com)

**REVISION LOG**

---

**REVISION LOG**

Original Issue of Manual .....May 26, 2016

## TABLE OF CONTENTS

<b>SECTION - PARAGRAPH, SUBJECT</b>	<b>PAGE</b>	<b>SECTION - PARAGRAPH, SUBJECT</b>	<b>PAGE</b>
FOREWORD .....	A	1.6 MAINTENANCE.....	1-12
SAFETY ALERT SYMBOLS AND SAFETY SIGNAL WORDS .....	B	Maintenance Hazards .....	1-12
Contact:.....	C		
In USA:.....	C	<b>SECTION - 2 - PREPARATION AND INSPECTION</b>	
Outside USA:.....	C	2.1 PERSONNEL TRAINING.....	2-1
REVISION LOG.....	D	Operator Training .....	2-1
		Training Supervision .....	2-1
		Operator Responsibility .....	2-1
<b>SECTION - 1 - SAFETY PRECAUTIONS</b>		2.2 PREPARATION, INSPECTION, AND MAINTENANCE .....	2-2
1.1 GENERAL.....	1-1	2.3 PRE-START INSPECTION .....	2-4
1.2 TRANSPORTING .....	1-2	2.4 DAILY WALK-AROUND INSPECTION.....	2-4
Tipping Hazards.....	1-2	General .....	2-4
1.3 PRE-OPERATION.....	1-4	2.5 FUNCTION CHECK.....	2-8
Operator Training and Knowledge .....	1-4		
Workplace Inspection .....	1-4	<b>SECTION - 3 - MACHINE OPERATION</b>	
Machine Inspection .....	1-5	3.1 GENERAL .....	3-1
1.4 OPERATION .....	1-6	3.2 MACHINE DESCRIPTION .....	3-1
General .....	1-6	3.3 MACHINE COMPONENT LOCATIONS .....	3-2
Trip and Fall Hazard .....	1-7	3.4 MACHINE OPERATION .....	3-4
Electrocution Hazard .....	1-8	Positioning and Leveling Machine .....	3-4
Tipping Hazards.....	1-9	Entering/Exiting The Platform .....	3-5
Crushing and Collision Hazards .....	1-10	Elevating/Lowering Platform .....	3-6
1.5 MOVING, LIFTING AND REPOSITIONING .....	1-11	3.5 TRANSPORTING, LIFTING AND TIE-DOWN PROCEDURES ..	3-6
General .....	1-11		
Additional Safety Information.....	1-11		

## TABLE OF CONTENTS

SECTION - PARAGRAPH, SUBJECT	PAGE
Loading.....	3-6
Vehicle Transport.....	3-6
Storage.....	3-7
3.6 DECAL INSTALLATION (ECOLIFT 50).....	3-8
3.7 DECAL INSTALLATION (ECOLIFT 70).....	3-10

### SECTION - 4 - EMERGENCY PROCEDURES

4.1 GENERAL INFORMATION.....	4-1
4.2 EMERGENCY OPERATION.....	4-1
Operator Unable to Control Machine.....	4-1
Platform Caught Overhead.....	4-1
Righting of Tipped Machine.....	4-1
4.3 INCIDENT NOTIFICATION.....	4-2
4.4 EMERGENCY LOWERING OPERATION.....	4-2

### SECTION - 5 - GENERAL SPECIFICATIONS

5.1 GENERAL SPECIFICATIONS.....	5-2
Machine Specifications.....	5-2

### SECTION - 6 - INSPECTION AND REPAIR LOG

SECTION - PARAGRAPH, SUBJECT	PAGE
<b>LIST OF FIGURES</b>	
2-1. Daily Walk-Around Inspection (EcoLift50).....	2-6
2-2. Daily Walk-Around Inspection (EcoLift70).....	2-7
2-3. Rear Wheel Auto Locking Brake.....	2-9
3-1. Machine Component Locations(EcoLift 50).....	3-2
3-2. Machine Component Locations(EcoLift 70).....	3-3
3-3. Bubble Level Indicator.....	3-4
3-4. Machine Positioning.....	3-5
3-5. Transport.....	3-7
3-6. Decal Installation (EcoLift 50).....	3-8
3-7. Decal Installation (EcoLift 70).....	3-10
4-1. Emergency Lowering Tool (EcoLift 50).....	4-3
4-2. Emergency Lowering Tool (EcoLift 70).....	4-3
4-3. Emergency Lowering (Ecolift 50 and Ecolift 70).....	4-4
5-1. Operating Specifications (EcoLift 50).....	5-3
5-2. Operating Specifications (EcoLift 70).....	5-3

### LIST OF TABLES

1-1 Minimum Approach Distances (M.A.D.).....	1-8
2-1 Inspection and Maintenance Table.....	2-3
3-1 Decal Installation Chart (See Figure 3-6.).....	3-9
3-2 Decal Installation Chart (See Figure 3-7.).....	3-11
5-1. Machine Specifications.....	5-2
5-2. Machine Dimensions.....	5-2
6-1 Inspection and Repair Log.....	6-1



## **SECTION 1. SAFETY PRECAUTIONS**

### **1.1 GENERAL**

This section outlines the necessary precautions for proper and safe machine usage and maintenance. In order to promote proper machine usage, it is mandatory that a daily routine is established based on the content of this manual. A maintenance program, using the information provided in the Service and Maintenance section, must also be established by a qualified person and must be followed to ensure that the machine is safe to operate.

The owner/user/operator/lessor/lessee of the machine must not accept operating responsibility until this manual has been read, training is accomplished, and operation of the machine has been completed under the supervision of an experienced and qualified operator.

These sections contain the responsibilities of the owner, user, operator, lessor, and lessee concerning safety, training, inspection, maintenance, application, and operation. If there are any questions with regard to safety, training, inspection, maintenance, application, and operation, please contact JLG Industries, Inc. (“JLG”).

### **WARNING**

**FAILURE TO COMPLY WITH THE SAFETY PRECAUTIONS LISTED IN THIS MANUAL COULD RESULT IN MACHINE DAMAGE, PROPERTY DAMAGE, PERSONAL INJURY OR DEATH.**

## SECTION 1 - SAFETY PRECAUTIONS

---

### 1.2 TRANSPORTING

#### Tipping Hazards

#### **⚠ WARNING**

FAILURE TO COMPLY WITH THE FOLLOWING TIPPING HAZARD INSTRUCTIONS COULD CAUSE THE UNIT TO TIP OVER OR BE HARD TO CONTROL WHEN BEING MOVED, WHICH COULD RESULT IN SERIOUS INJURY OR DEATH.



- Check travel path for persons, holes, bumps, drop-offs, obstructions, debris, and coverings which may conceal other hazards.
- Before placing machine on floors, trucks and other surfaces, check allowable capacity of surfaces.

- On a level surface, always push machine from the platform end with the mast end leading the way.
- Watch for obstructions around machine and overhead.

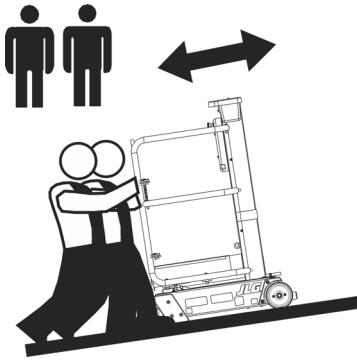

- Two persons are required on slopes up to 5°. A forklift must be used when moving units on slopes greater than 5°.
- Always travel up or down a slope with the platform end of the machine positioned towards the low side of the slope. The operator and assistant must walk side by side to guide the machine.



- Never position the unit sideways on a slope.
- Do not elevate the platform or move the machine on a soft surface.
- Use caution and check clearances when moving machine in restricted or close quarters.
- Always use an assistant when moving machine in areas where vision is obstructed.
- Keep non-operating personnel at least 6 ft. (1.8m) away from machine during moving operations.

## SECTION 1 - SAFETY PRECAUTIONS

---

### 1.3 PRE-OPERATION

#### Operator Training and Knowledge

- This manual must be read and understood in its entirety before operating the machine. For clarification, questions, or additional information regarding any portions of this manual, contact JLG Industries, Inc.

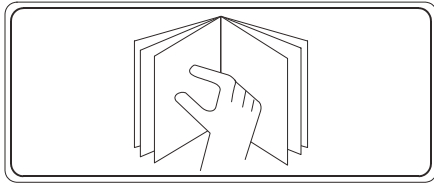

- An operator must not accept operating responsibilities until adequate training has been given by competent and authorized persons.
- Allow only those authorized and qualified personnel to operate the machine who have demonstrated that they understand the safe and proper operation and maintenance of the unit.
- Read, understand, and obey all DANGERS, WARNINGS, CAUTIONS, and operating instructions on the machine and in this manual.

- Ensure that the machine is to be used in a manner which is within the scope of its intended application as determined by JLG.
- All operating personnel must be familiar with the emergency controls and emergency operation of the machine as specified in this manual.
- Read, understand, and obey all applicable employer, local, and governmental regulations as they pertain to your utilization and application of the machine.

#### Workplace Inspection

- Precautions to avoid all hazards in the work area must be taken by the user before and during operation of the machine.
- Do not operate or raise the platform from a position on trucks, trailers, railway cars, floating vessels, scaffolds or other equipment unless the application is approved in writing by JLG.
- Before operation, check work area for overhead hazards such as electric lines, bridge cranes, and other potential overhead obstructions.
- Check floor surfaces for holes, bumps, drop-offs, obstructions, debris, concealed holes, and other potential hazards.

- Check the work area for hazardous locations. Do not operate the machine in hazardous environments unless approved for that purpose by JLG.
- Ensure that the ground conditions are adequate to support the maximum tire load indicated on the tire load decals located on the chassis adjacent to each wheel.
- Ensure all safety devices are operating properly. Modification of these devices is a safety violation.

### **WARNING**

**MODIFICATION OR ALTERATION OF AN AERIAL WORK PLATFORM SHALL BE MADE ONLY WITH PRIOR WRITTEN PERMISSION FROM THE MANUFACTURER.**

### **Machine Inspection**

- Do not operate this machine until the inspections and functional checks have been performed as specified in Section 2 of this manual.
- Do not operate this machine until it has been serviced and maintained according to the maintenance and inspection requirements as specified in the Service and Maintenance section of this manual.
- Do not operate any machine on which the safety or instruction placards or decals are missing or illegible.
- Check the machine for modifications to original components. Ensure that any modifications have been approved by JLG.
- Avoid accumulation of debris on platform deck. Keep mud, oil, grease, and other slippery substances from footwear and platform deck.

## **SECTION 1 - SAFETY PRECAUTIONS**

---

### **1.4 OPERATION**

#### **General**

- Machine operation requires your full attention. Bring the machine to a full stop before using any device, i.e. cell phones, two-way radios, etc. that will distract your attention from safely operating the machine.
- Do not use the machine for any purpose other than positioning personnel, their tools, and equipment.
- Before operation, the user must be familiar with the machine capabilities and operating characteristics of all functions.
- Never operate a malfunctioning machine. If a malfunction occurs, shut down the machine. Remove the unit from service and notify the proper authorities.
- Do not remove, modify, or disable any safety devices.
- Do not allow personnel to tamper with or operate the machine from the ground with personnel in the platform, except in an emergency.
- Do not carry materials directly on platform railing unless approved by JLG.
- Always ensure that power tools are properly stowed and never left hanging by their cord from the platform work area.
- Fully lower platform before leaving machine.
- Remove all rings, watches, and jewelry when operating machine. Do not wear loose fitting clothing or long hair unrestrained which may become caught or entangled in equipment.
- Persons under the influence of drugs or alcohol or who are subject to seizures, dizziness or loss of physical control must not operate this machine.

### Trip and Fall Hazard

- Prior to operation, ensure all gates and rails are fastened and secured in their proper position.

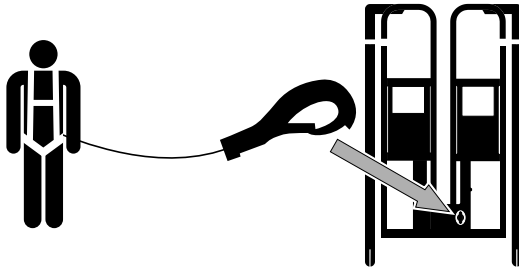

- JLG recommends that the operator utilizes a fall/travel restraint system in the platform with a lanyard attached to an authorized lanyard anchorage point. For further information regarding fall protection requirements on JLG products, contact JLG.
- Identify the designated lanyard anchorage point at the platform and securely attach the lanyard. Attach only one (1) lanyard per lanyard anchorage point.
- Enter and exit only through gate area. Use extreme caution when entering or leaving platform. Ensure that the platform assembly is fully lowered. Face the machine when entering

or leaving the platform. Always maintain “three point contact” with the machine, using two hands and one foot or two feet and one hand at all times during entry and exit.

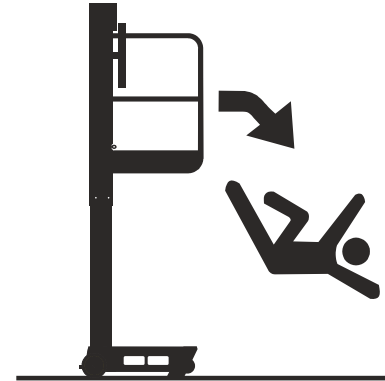

- Keep both feet firmly positioned on the platform floor at all times. Never position ladders, boxes, steps, planks, or similar items on unit to provide additional reach for any purpose.
- Never use the mast assembly to gain access to or leave the platform.
- Keep oil, mud, and slippery substances cleaned from footwear and the platform floor.

### Electrocution Hazard

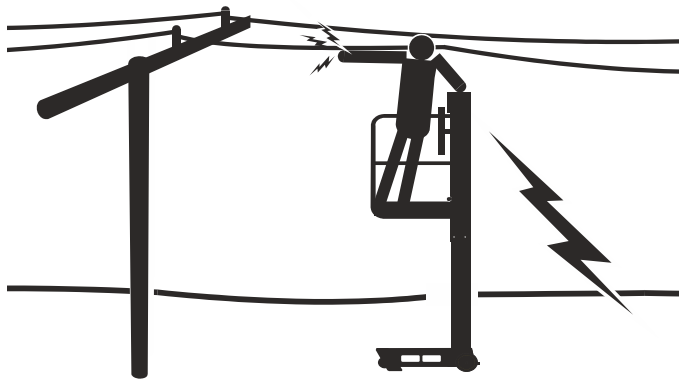

equipment from any electrical line or apparatus carrying up to 50,000 volts. One foot additional clearance is required for every additional 30,000 volts or less.

**Table 1-1. Minimum Approach Distances (M.A.D.)**

VOLTAGE RANGE (Phase to Phase)	MINIMUM APPROACH DISTANCE in Feet (Meters)
0 to 50 KV	10 (3)
Over 50KV to 200 KV	15 (5)
Over 200 KV to 350 KV	20 (6)
Over 350 KV to 500 KV	25 (8)
Over 500 KV to 750 KV	35 (11)
Over 750 KV to 1000 KV	45 (14)

**NOTE:** *This requirement shall apply except where employer, local or governmental regulations are more stringent.*

- This machine is not insulated and does not provide protection from contact or proximity to electrical current.
- Maintain distance from electrical lines, apparatus, or any energized (exposed or insulated) parts according to the Minimum Approach Distance (MAD) as shown in Table 1-1.
- Allow for machine movement and electrical line swaying.
- Maintain a clearance of at least 10 ft. (3m) between any part of the machine and its occupants, their tools, and their

- The minimum approach distance may be reduced if insulating barriers are installed to prevent contact, and the barriers are rated for the voltage of the line being guarded. These barriers shall not be part of (or attached to) the machine. The minimum approach distance shall be reduced to a distance within the designed working dimensions of the insulating barrier. This determination shall be made by a qualified person in accordance with the employer, local,



or governmental requirements for work practices near energized equipment.

### **⚠ DANGER**

**DO NOT MANEUVER MACHINE OR PERSONNEL INSIDE PROHIBITED ZONE (MAD). ASSUME ALL ELECTRICAL PARTS AND WIRING ARE ENERGIZED UNLESS KNOWN OTHERWISE.**

### **Tipping Hazards**

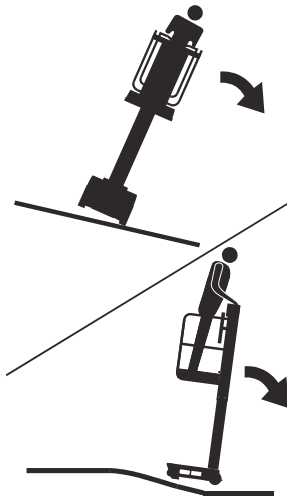

- Ensure that the ground conditions are adequate to support the maximum tire load indicated on the tire load decals located on the chassis adjacent to each wheel. Do not operate machine on unsupported surfaces.
- Do not elevate platform while on or near a sloping, uneven, or soft surface. Ensure machine is positioned on a firm, level and smooth surface before elevating platform.
- Before operating on floors, bridges, trucks, and other surfaces, check allowable capacity of the surfaces.
- Never exceed the maximum work load as specified on the platform. Keep all loads within the confines of the platform, unless authorized by JLG.
- Keep the chassis of the machine a minimum of 2 ft. (0.6m) from holes, bumps, drop-offs, obstructions, debris, concealed holes, and other potential hazards at the ground level.
- Never operate machine in high wind, rain or snow.
- Do not perform work that will subject unit to a horizontal force or create a swaying motion of the platform.
- Never attempt to use the machine as a crane. Do not tie-off machine to any adjacent structure. Never attach wire, cable, or any similar items to platform.
- Do not cover the platform sides or carry large surface area items in the platform. The addition of such items increases the exposed wind area of the machine.

## SECTION 1 - SAFETY PRECAUTIONS

---

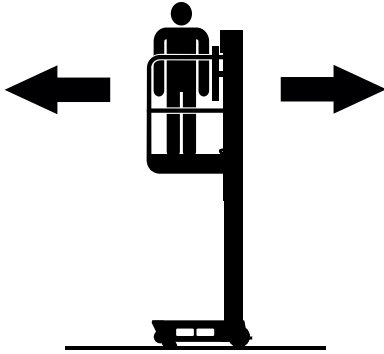

- Do not increase the platform size with unauthorized deck extensions or attachments.
- If the mast assembly or platform is caught so that one or more wheels are off the ground, platform personnel must be removed before attempting to free the machine. Use cranes, forklift trucks, or other appropriate equipment to stabilize machine and remove personnel.

### Crushing and Collision Hazards

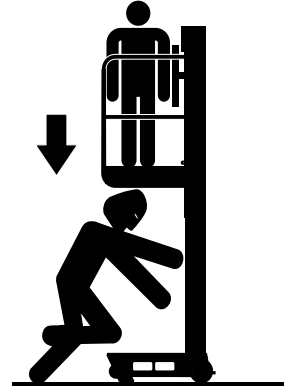

- Approved head gear must be worn by all operating and ground personnel.
- Check clearances above, on sides, and bottom of platform when lifting or lowering platform.
- During operation, keep all body parts inside platform railing.
- Keep non-operating personnel at least 6 ft. (1.8m) away from machine during all operations.

- When moving the machine, the operator must limit travel speed according to conditions of ground surface, congestion, visibility, slope, location of personnel, and other factors.
- Exercise extreme caution at all times to prevent obstacles from striking or interfering with operating controls and persons in the platform.
- Ensure that operators of other overhead and floor level machines are aware of the aerial work platform's presence. Disconnect power to overhead cranes. Barricade floor area if necessary.
- Do not operate over ground personnel. Warn personnel not to work, stand, or walk under a raised platform. Position barricades on floor as necessary.

### 1.5 MOVING, LIFTING AND REPOSITIONING

#### General

- Never allow personnel in platform while moving, lifting or repositioning the machine.
- This machine shall not be towed by a vehicle.
- Do not move assembled unit on wheels over soft or uneven surfaces, or over obstructions, bumps, debris, etc.
- Disassemble unit to transport over uneven or sloped ground, or in a vehicle.
- Ensure platform is fully retracted and completely empty of tools prior to disassembly, lifting or hauling.
- Refer to the Machine Operation section of this manual for lifting information.

#### Additional Safety Information

- Do not use machine as ground for welding.

## **SECTION 1 - SAFETY PRECAUTIONS**

---

### **1.6 MAINTENANCE**

This sub-section contains general safety precautions which must be observed during maintenance of this machine. It is of utmost importance that maintenance personnel pay strict attention to these precautions to avoid possible injury to personnel or damage to the machine or property. A maintenance program must be established by a qualified person and must be followed to ensure that the machine is safe.

#### **Maintenance Hazards**

- Ensure that all moving parts are secured from inadvertent motion prior to performing any adjustments or repairs.
  - Never work under an elevated platform until it has been fully lowered to the full down position, if possible, or otherwise supported and restrained from movement with appropriate safety props, blocking, or overhead supports.
  - Ensure replacement parts or components are identical or equivalent to original parts or components.
  - Never attempt to move heavy parts without the aid of a mechanical device. Do not allow heavy objects to rest in an unstable position. Ensure adequate support is provided when raising components of the machine.
  - Use only approved non-flammable cleaning solvents.
- Do not replace items critical to stability, with items of different weight or specification. Do not modify unit in any way to affect stability.

#### **WARNING**

**MODIFICATION OR ALTERATION OF AN AERIAL WORK PLATFORM SHALL BE MADE ONLY WITH PRIOR WRITTEN PERMISSION FROM THE MANUFACTURER.**

### SECTION 2. PREPARATION AND INSPECTION

#### 2.1 PERSONNEL TRAINING

The aerial platform is a personnel handling device; so it is necessary it be operated and maintained only by trained personnel.

Persons under the influence of drugs or alcohol or who are subject to seizures, dizziness or loss of physical control must not operate this machine.

##### **Operator Training**

##### **Operator training must cover:**

1. Use and limitations of the controls in the platform and at the ground, emergency controls and safety systems.
2. Control labels, instructions, and warnings on the machine.
3. Rules of the employer and government regulations.
4. Use of approved fall protection device.
5. Enough knowledge of the mechanical operation of the machine to recognize a malfunction or potential malfunction.
6. The safest means to operate the machine where overhead obstructions, other moving equipment, and obstacles, depressions, holes, drop-offs are present.

7. Means to avoid the hazards of unprotected electrical conductors.
8. Specific job requirements or machine application.

##### **Training Supervision**

Training must be done under the supervision of a qualified person in an open area free of obstructions until the trainee has developed the ability to safely control and operate the machine.

##### **Operator Responsibility**

The operator must be instructed that he/she has the responsibility and authority to shut down the machine in case of a malfunction or other unsafe condition of either the machine or the job site.

## **SECTION 2 - PREPARATION AND INSPECTION**

---

### **2.2 PREPARATION, INSPECTION, AND MAINTENANCE**

The following table covers the periodic machine inspections and maintenance recommended by JLG Industries, Inc. Consult local regulations for further requirements for aerial work platforms. The frequency of inspections and maintenance must be increased as necessary when the machine is used in a harsh or hostile environment, if the machine is used with increased frequency, or if the machine is used in a severe manner.

#### **NOTICE**

**JLG INDUSTRIES, INC. RECOGNIZES A FACTORY-TRAINED SERVICE TECHNICIAN AS A PERSON WHO HAS SUCCESSFULLY COMPLETED THE JLG SERVICE TRAINING SCHOOL FOR THE SPECIFIC JLG PRODUCT MODEL.**

## SECTION 2 - PREPARATION AND INSPECTION

**Table 2-1. Inspection and Maintenance Table**

TYPE	FREQUENCY	PRIMARY RESPONSIBILITY	SERVICE QUALIFICATION	REFERENCE
Pre-Start Inspection	Before using each day; or whenever there's an Operator change.	User or Operator	User or Operator	Operator and Safety Manual
Pre-Delivery Inspection <i>(See Note)</i>	Before each sale, lease, or rental delivery.	Owner, Dealer, or User	Qualified JLG Mechanic	Service and Maintenance Manual and applicable JLG inspection form
Frequent Inspection	In service for 3 months or 150 hours, whichever comes first; or; Out of service for a period of more than 3 months; or Purchased used.	Owner, Dealer, or User	Qualified JLG Mechanic	Service and Maintenance Manual and applicable JLG inspection form
Annual Machine Inspection	Annually, no later than 13 months from the date of prior inspection.	Owner, Dealer, or User	Factory Trained Service Technician <i>(Recommended)</i>	Service and Maintenance Manual and applicable JLG inspection form
Preventative Maintenance	At intervals as specified in the Service and Maintenance Manual.	Owner, Dealer, or User	Qualified JLG Mechanic	Service and Maintenance Manual
<b>NOTE:</b> <i>Inspection forms are available from JLG. Use the Service and Maintenance Manual to perform inspections.</i>				

## SECTION 2 - PREPARATION AND INSPECTION

---

### 2.3 PRE-START INSPECTION

The Pre-Start Inspection should include each of the following:

1. **Cleanliness** – Check all surfaces for leakage, debris or foreign objects.
2. **Decals and Placards** – Check all for cleanliness and legibility. Make sure none of the decals and placards are missing. Make sure all illegible decals and placards are cleaned or replaced. (Reference Section 3 - Decal Installations).
3. **Operation and Safety Manual** – Make sure a copy of the Operation and Safety Manual, AEM Safety Manual, and ANSI Manual of Responsibilities is enclosed in the weather resistant manual storage container.
4. **Daily Walk-Around Inspection** – Refer to Section 2.4.
5. **Function Check** – Once the Walk-Around Inspection is complete, perform a function check of all systems in an area free of overhead and ground level obstructions. Refer to Section 2.4 for more specific instructions.

### 2.4 DAILY WALK-AROUND INSPECTION

#### General

Begin the Walk-Around Inspection at item 1 (*See Figure 2-1. on page 2-6 and Figure 2-2. on page 2-7*). Continue around machine checking each item in check list.

#### **NOTICE**

**DO NOT OVERLOOK VISUAL INSPECTION OF THE BASE FRAME UNDERSIDE. CHECK THIS AREA FOR OBJECTS OR DEBRIS WHICH COULD CAUSE EXTENSIVE MACHINE DAMAGE.**

#### **INSPECTION NOTE:**

*On each item, make sure there are no loose or missing parts, they are securely fastened, no visible damage exists in addition to any other criteria mentioned.*

1. **Front Swivel Castor Wheels** - Properly secured, undamaged, wheels and castor turn freely.
2. **Platform** - See Inspection Note.
3. **Auto-Lock - Rear Wheel Brakes** - Check for any debris stuck to or around wheels. Look under the brush strip at the rear of the chassis, Check brake cam plates are undamaged and that the two attaching screws are tight, Check that the brake pins are not bent or broken.



4. **Gates** - Platform railings; entry gate in proper working order, closing properly.
5. **Tool Tray** - See Inspection Note.
6. **Flywheel Handle** - See Inspection Note.
7. **Flywheel** - See Inspection Note.
8. **Emergency Lowering Tool** - Check emergency lowering tool is attached on the chassis.
9. **Bubble Level Indicator** - Check bubble level Indicator is clean, secure and responds to movement.
10. **Mast Assembly** - See Inspection Note.
11. **Lanyard Attach Point** - See Inspection Note.
12. **Rubber Foot (Pad) (EcoLift50)** - Check that the front rubber chassis feet (pads) are undamaged and secured.
13. **Fold-Down Platform Step (EcoLift 70)** - See Inspection Note.

## SECTION 2 - PREPARATION AND INSPECTION

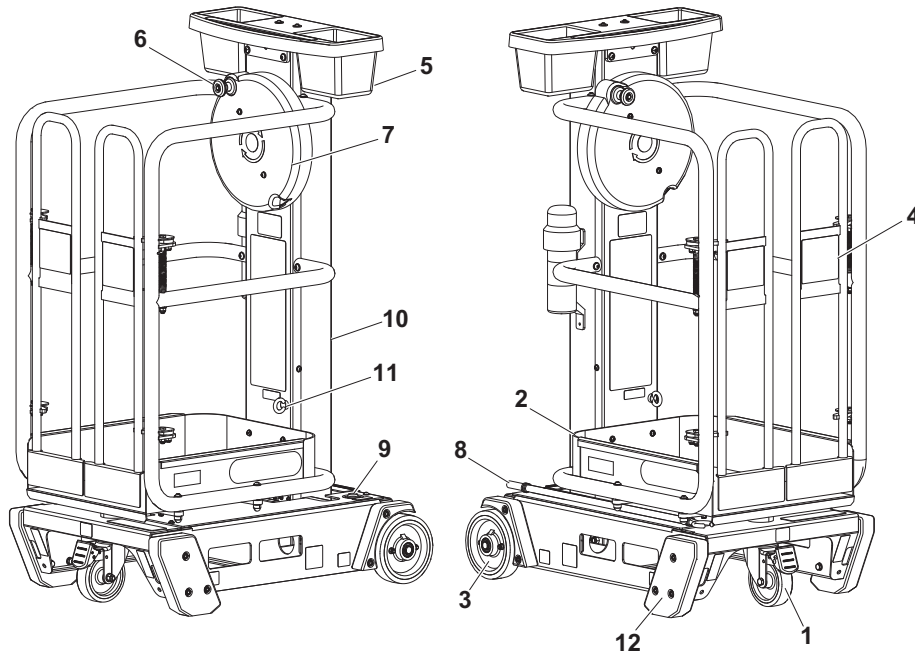

1. Swivel Castor
2. Platform
3. Auto-Lock Braked Wheels
4. Gates
5. Tool Tray
6. Flywheel Handle
7. Flywheel
8. Emergency Lowering Tool
9. Bubble Level Indicator
10. Mast Assembly
11. Lanyard Attach Point
12. Rubber Foot (Pad)

**Figure 2-1. Daily Walk-Around Inspection (EcoLift 50)**

## SECTION 2 - PREPARATION AND INSPECTION

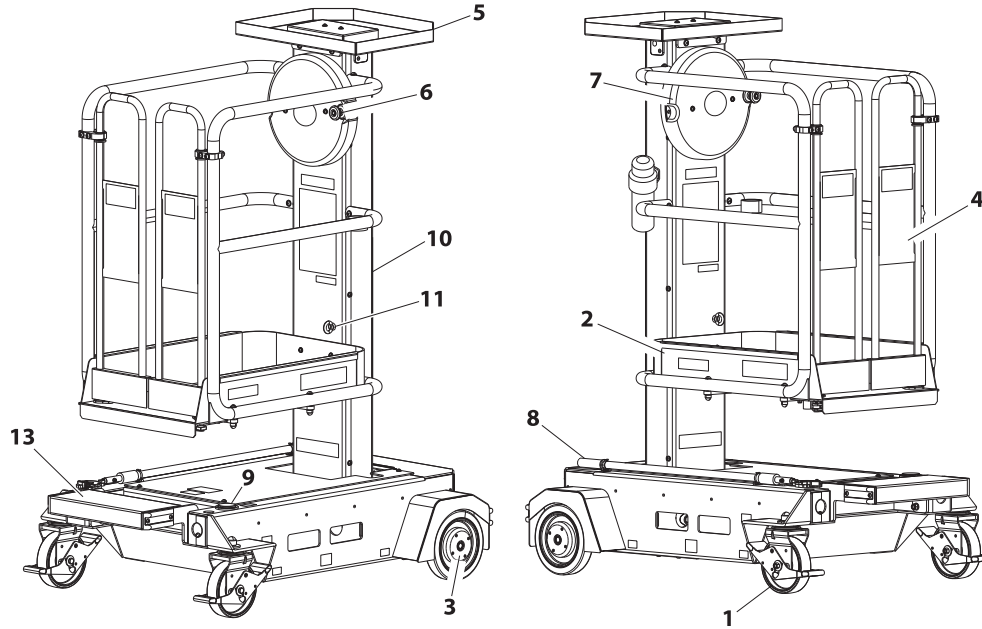

1. Swivel Castor
2. Platform
3. Auto-Lock Braked Wheels
4. Gates
5. Tool Tray
6. Flywheel Handle
7. Flywheel
8. Emergency Lowering Tool
9. Bubble Level Indicator
10. Mast Assembly
11. Lanyard Attach Point
12. Not Used
13. Fold-Down Platform Step

**Figure 2-2. Daily Walk-Around Inspection (EcoLift 70)**

## SECTION 2 - PREPARATION AND INSPECTION

---

### 2.5 FUNCTION CHECK

The function check of all systems should be performed in an area free of overhead and ground level obstructions. Perform a function check as follows:

1. Set-up machine for operation according to instructions in Section 3.
2. **EcoLift 70** - Check front caster wheels lock when engaged and keep machine from rolling.
3. **Enter platform:** Check that platform entry gates automatically close completely while in platform.
4. **EcoLift 50** - When you step into the platform, the front caster wheel should retract and machine should be resting on the front foot pads.
5. Check 'fly-wheel' operating handle works correctly. Hold handle firmly and pull operating knob towards you, release, knob should spring back to lock wheel.
6. While in platform, raise and lower platform 2 ft. to 3 ft. (0.61m to 0.92m) several times. Check for smooth elevation and lowering of platform.
7. With the aid of an assistant, check the operation of the rear wheel auto locking brake mechanism. When the platform is elevated and the mast is clear of the chassis, observe the action of the brake cams and movement of the brake pins, ensure the pins fully engage the rear wheel brake disks when the platform is elevated and release when the platform is fully lowered. (See Figure 2-3.)

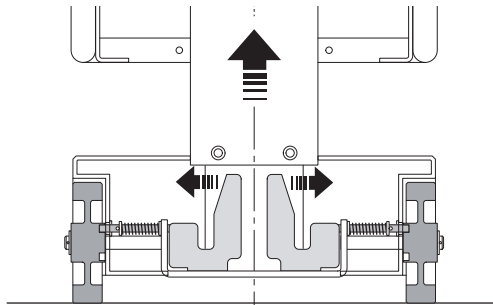

**Rear Wheel Auto Locking Brake - Engaged**

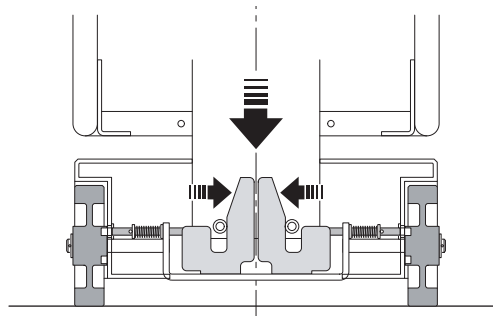

**Rear Wheel Auto Locking Brake - Disengaged**

**Figure 2-3. Rear Wheel Auto Locking Brake**



## **SECTION 3. MACHINE OPERATION**

### **3.1 GENERAL**

#### **NOTICE**

**THE MANUFACTURER HAS NO DIRECT CONTROL OVER MACHINE APPLICATION AND OPERATION. THE USER AND OPERATOR ARE RESPONSIBLE FOR CONFORMING WITH GOOD SAFETY PRACTICES.**

This section provides the necessary information needed to understand control function and operation.

### **3.2 MACHINE DESCRIPTION**

The machine is manually propelled push-a-round machine, with a work platform mounted to an elevating mast mechanism. The personnel lift's intended purpose is to provide personnel (with their tools & supplies) access to areas above ground level.

On a firm, level surface, the machine can be pushed around on its wheels from work area to work area, transported by forklift truck, or loaded onto a suitable vehicle.

From the platform the operator can manually raise and lower the platform using the flywheel cranking mechanism mounted on the front of the mast. The mast is belt driven and extended with the help of an internal pressurized gas cylinder. The platform must **ONLY** be elevated on a **FIRM, LEVEL, and UNIFORM SURFACE.**

**3.3 MACHINE COMPONENT LOCATIONS**

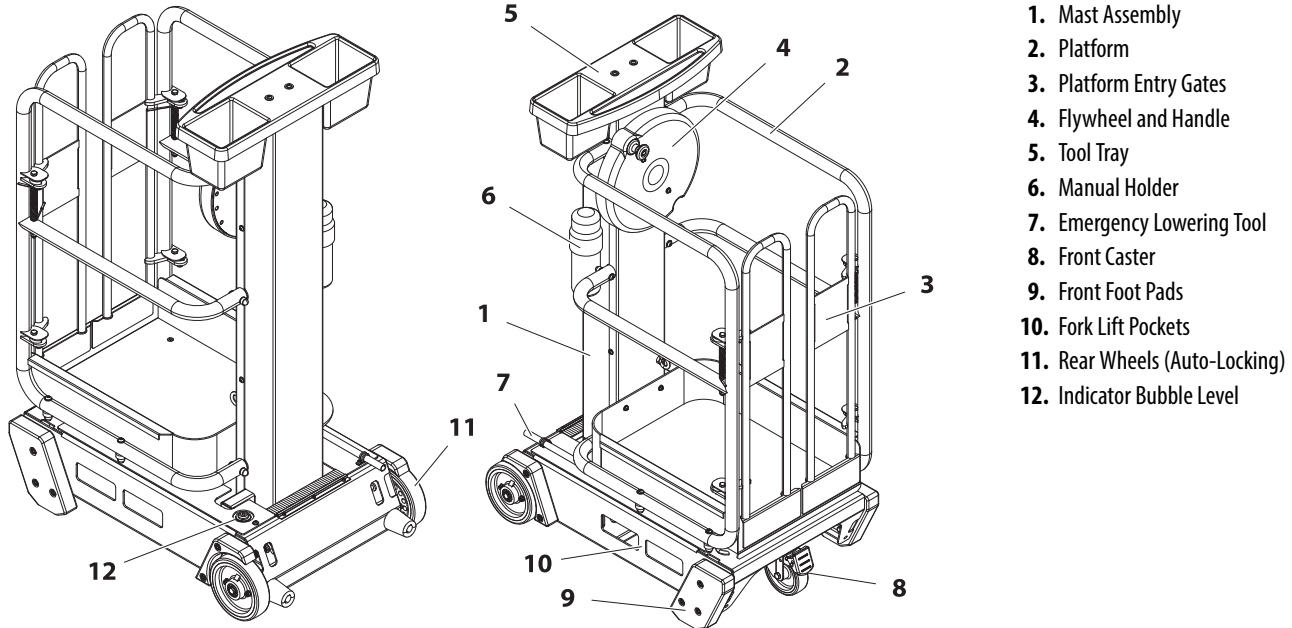

**Figure 3-1. Machine Component Locations(EcoLift 50)**



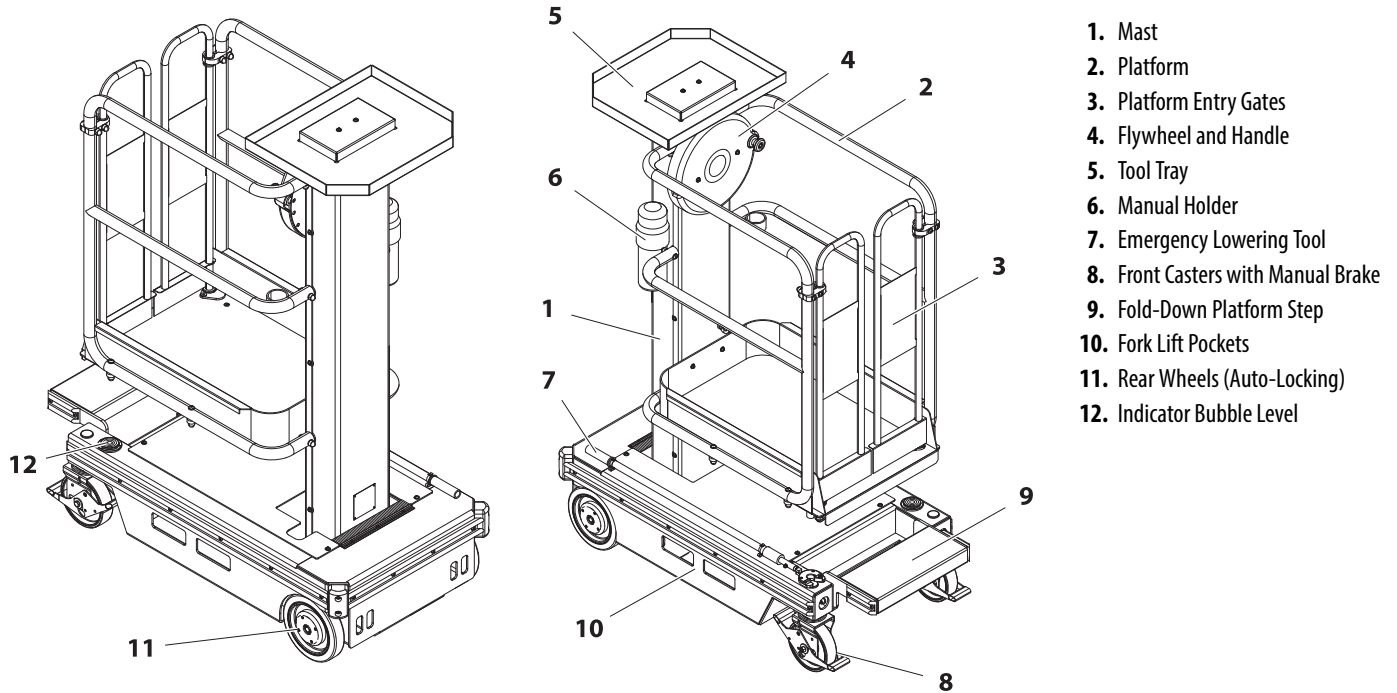

**Figure 3-2. Machine Component Locations(EcoLift 70)**

## SECTION 3 - MACHINE OPERATION

### 3.4 MACHINE OPERATION

#### **CAUTION**

**NEVER ATTEMPT TO USE THE FLYWHEEL HANDLE TO RAISE OR LOWER THE PLATFORM WHILE STANDING NEXT TO THE MACHINE, OR WITH AN EMPTY PLATFORM.**

The following control conditions must be met before elevating the platform:

- Make sure the pre-start inspection (Section 2) has been completed **and** the machine is safe to use.
- Check that machine base is level and is set up properly for operation.
- Both platform swing-in entry gates must be closed once the operator is in the platform.

#### **NOTICE**

**JLG RECOMMENDS THAT THE OPERATOR UTILIZES A FALL/TRAVEL RESTRAINT SYSTEM IN THE PLATFORM WITH A LANYARD ATTACHED TO THE AUTHORIZED LANYARD ANCHORAGE POINT IN THE PLATFORM.**

### Positioning and Leveling Machine

1. Position machine under work area on a firm, level, and uniform, supporting surface
2. Ensure the level indicator is centered and machine is level. (See Figure 3-3.)

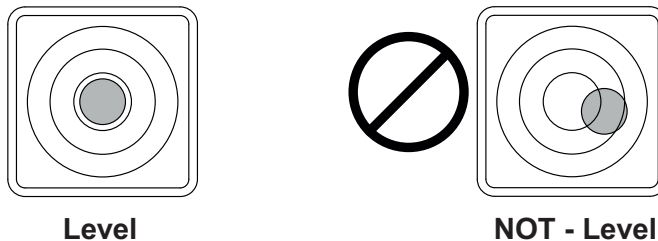

**Figure 3-3. Bubble Level Indicator**

3. Check that ALL wheels/support pads on the front/rear of machine are resting on the supporting surface.
4. **EcoLift 50** - Once you have entered the platform check that the front castor has retracted and machine is resting on the front rubber foot pads.  
**EcoLift 70** - Lock each of the front castor wheels before entering the platform. (See Figure 3-4.)

### Entering/Exiting The Platform

#### **⚠ WARNING**

**DO NOT EXCEED MAXIMUM PLATFORM CAPACITY. MAXIMUM CAPACITY INCLUDES PERSONNEL IN PLATFORM PLUS WEIGHT IN TOOL TRAY OR ANY OTHER WEIGHT PLACED IN PLATFORM.**

1. Always maintain “three point contact” with the machine, using two hands and one foot or two feet and one hand at all times during entry and exit.
2. Attach your lanyard to the lanyard attachment point in the lower right hand corner of the Mast.
3. Make sure entry gates are closed behind you.
4. Once in the platform and the entry gates have fully closed the platform is ready for the operation.

#### **⚠ WARNING**

**BEFORE OPERATING PLATFORM CHECK AROUND AND OVERHEAD FOR ANY OBSTACLES OR PERSONNEL THAT MAY COME INTO CONTACT WITH MACHINE WHILE ELEVATING OR LOWERING THE PLATFORM. IF NECESSARY, EXIT MACHINE AND REPOSITION BEFORE PROCEEDING.**

5. Before exiting the platform, be certain platform is fully lowered.

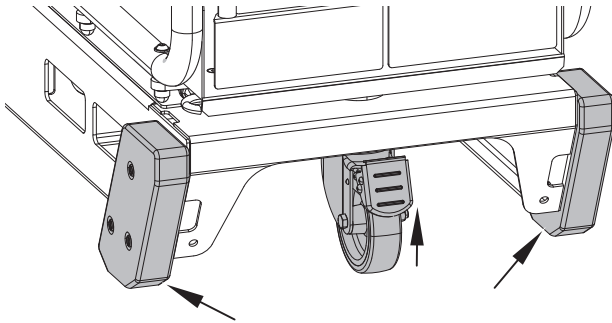

**EcoLift 50 - Swivel Castor and Rubber Foot Pads**

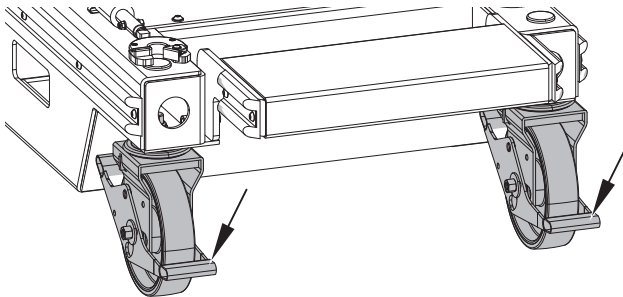

**EcoLift 70 - Lock Castor Brakes**

**Figure 3-4. Machine Positioning**

## SECTION 3 - MACHINE OPERATION

---

### Elevating/Lowering Platform

1. Check there are no overhead obstructions.
2. To elevate the platform, pull out on the flywheel handle and turn flywheel clockwise.
3. To lower the platform, pull out on the flywheel handle and turn flywheel counterclockwise.
4. To stop elevating and lowering operation, stop turning the flywheel and release the handle, continue to turn flywheel slightly to lock handle in place when released.

#### **WARNING**

**CRUSHING HAZARD - BE AWARE OF DESCENDING PLATFORM WHEN LOWERING THE PLATFORM. KEEP HANDS OR FEET OFF THE MAST ASSEMBLY AND FROM BENEATH PLATFORM.**

### 3.5 TRANSPORTING, LIFTING AND TIE-DOWN PROCEDURES

#### Loading

If loading machine up a ramp onto a trailer with the aid of a winch, connect the winch cable to the castor/gate end of the chassis using the tie-down holes provided. First run a strap through the holes, and then connect the winch cable to the strap. (See Figure 3-5.)

Ensure the castor(s) are rolling freely, and that the platform is fully lowered in the transport position. Before disconnecting the machine from the winch cable, engage each castor brake.

#### Vehicle Transport

Always ensure that the machine is transported in the upright position. Never lay flat.

Ensure the transport vehicle is parked on a level surface.

The machine can be loaded via a forklift, tail-lift, or winch. Never push the machine up a slope greater than 5° without the aid of a winch or forklift.

**EcoLift 70** - Ensure the castor wheel locks are engaged and that the forklift tines are fully engaged through the forklift pockets on the base frame.

Use at least two straps, with one strap over the chassis, around the mast section and out to the rear of the machine. The other strap should be fed through the front of the chassis and the straps taken forward, so that the machine is tied down in four diagonal directions. (See Figure 3-5.)

#### **NOTICE**

**NEVER PLACE A STRAP THROUGH THE PLATFORM OR HANDRAILS THIS COULD RESULT IN MACHINE DAMAGE. DO NOT USE EXCESSIVE FORCE WHEN TIGHTENING STRAPS.**

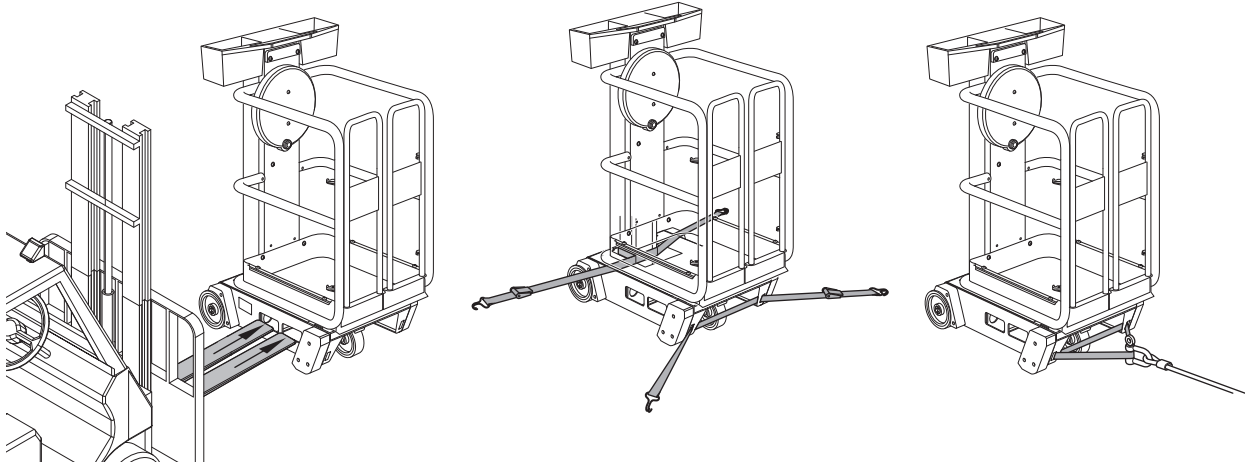

**Figure 3-5. Transport**

**Storage**

If the machine is due to be stored for periods in excess of one month, the following precautions should be taken:

- ensure the platform is fully lowered and
- place a cover over the machine

Store or transport the machine in an upright position only.

Upon removal from storage and prior to returning to use, ensure machine pre-operation checks are carried out thoroughly.

3.6 DECAL INSTALLATION (ECOLIFT 50)

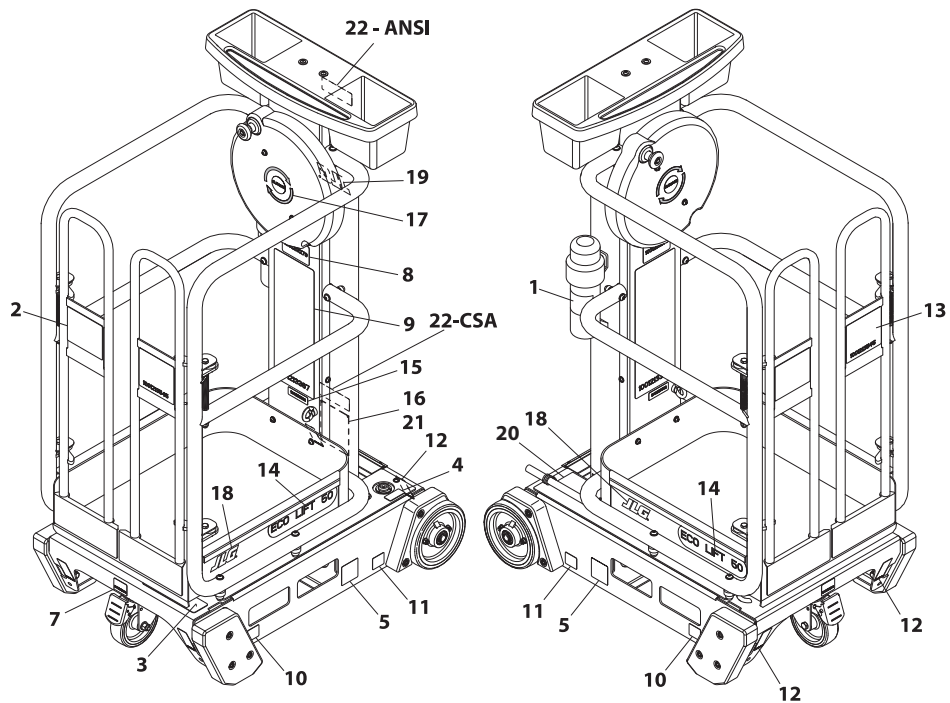

Figure 3-6. Decal Installation (EcoLift 50)

**Table 3-1. Decal Installation Chart (See Figure 3-6.)**

<b>EcoLift 50</b>		
<b>Item</b>	<b>Part Number ANSI - English (1001213427)</b>	<b>Part Number CSA - French (1001215011)</b>
<b>1</b>	1701509	
<b>2</b>	1703781	1704795
<b>3</b>	1703786	1704039
<b>4</b>	1703789	1704041
<b>5</b>	1703817	
<b>6</b>	—	
<b>7</b>	1001213208	
<b>8</b>	1001213279	
<b>9</b>	1001213367	1001215007
<b>10</b>	1001213439	
<b>11</b>	1001213440	
<b>12</b>	1001213442	
<b>13</b>	1001213545	1001215010
<b>14</b>	1001213548	
<b>15</b>	1001213582	

**Table 3-1. Decal Installation Chart (See Figure 3-6.)**

<b>EcoLift 50</b>		
<b>Item</b>	<b>Part Number ANSI - English (1001213427)</b>	<b>Part Number CSA - French (1001215011)</b>
<b>16</b>	1001213621	
<b>17</b>	1001213997	
<b>18</b>	1001214108	
<b>19</b>	1001214109	
<b>20</b>	1001214125	
<b>21</b>	—	
<b>22</b>	1001215043	1706351

## SECTION 3 - MACHINE OPERATION

### 3.7 DECAL INSTALLATION (ECOLIFT 70)

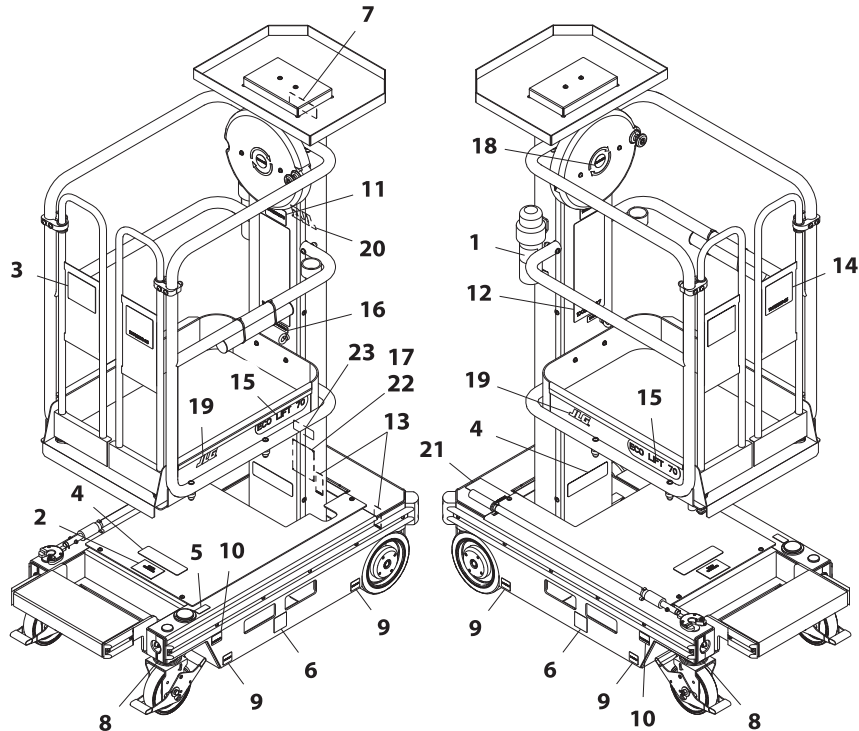

Figure 3-7. Decal Installation (EcoLift 70)



**Table 3-2. Decal Installation Chart (See Figure 3-7.)**

EcoLift 70		
Item	Part Number ANSI - English (1001213185)	Part Number CSA - French (1001215012)
1	1701509	
2	1702391	1001215113
3	1703781	1704795
4	1703786	1704039
5	1703789	1704041
6	1703817	
7	1001215043	1001214049
8	1001213202	
9	1001213205	
10	1001213208	
11	1001213279	
12	1001213367	1001215007
13	1001213442	
14	1001213545	1001215010
15	1001213549	

**Table 3-2. Decal Installation Chart (See Figure 3-7.)**

EcoLift 70		
Item	Part Number ANSI - English (1001213185)	Part Number CSA - French (1001215012)
16	1001213582	1001215009
17	1001213621	
18	1001213997	1001215005
19	1001214108	
20	1001214109	
21	1001214125	
22	—	
23	—	1706351



## **SECTION 4. EMERGENCY PROCEDURES**

### **4.1 GENERAL INFORMATION**

This section explains the steps to be taken in case of an emergency situation during operation.

### **4.2 EMERGENCY OPERATION**

#### **Operator Unable to Control Machine**

IF THE PLATFORM OPERATOR IS PINNED, TRAPPED OR UNABLE TO OPERATE OR CONTROL THE MACHINE, USE THE FOLLOWING INSTRUCTIONS AS A GUIDELINE:

1. Other personnel should operate the machine from ground as required.
2. Only qualified personnel in the platform may use the platform controls. **DO NOT CONTINUE OPERATION IF CONTROLS DO NOT FUNCTION PROPERLY.**

Cranes, forklift trucks or other equipment can be used to remove the platform occupant and stabilize motion of the machine.

#### **Platform Caught Overhead**

If the platform becomes jammed or snagged in overhead structures or equipment, rescue the platform occupant prior to freeing the machine.

#### **Righting of Tipped Machine**

Before righting a tipped machine, check machine for any damage which may prevent it from setting properly on its base wheels once in a vertical position, (i.e. base wheels damaged, base frame distorted, etc.). Use a crane, forklift or other suitable lifting equipment and carefully lift the machine to an upright position.

### **NOTICE**

**FOLLOWING ANY ACCIDENT, THOROUGHLY INSPECT THE MACHINE AND TEST ALL FUNCTIONS. DO NOT ELEVATE PLATFORM UNTIL YOU ARE SURE THAT ALL DAMAGE HAS BEEN REPAIRED, IF REQUIRED AND THAT ALL CONTROLS ARE OPERATING CORRECTLY.**

## SECTION 4 - EMERGENCY PROCEDURES

---

### 4.3 INCIDENT NOTIFICATION

JLG Industries, Inc. must be notified immediately of any incident involving a JLG product. Even if no injury or property damage is evident, the factory should be contacted by telephone and provided with all necessary details.

USA: 877-JLG-SAFE (554-7233)

Outside USA: 717-485-5161

E-mail: productsafety@jlg.com

Failure to notify the manufacturer of an incident involving a JLG Industries product within 48 hours of such an occurrence may void any warranty consideration on that particular machine.

### 4.4 EMERGENCY LOWERING OPERATION

#### **WARNING**

**DO NOT CLIMB OUT OF THE PLATFORM WHILE ELEVATED. THIS MAY AFFECT THE MACHINE'S BALANCE, CAUSING IT TO TIP OVER. ONLY EXIT THE PLATFORM VIA THE PLATFORM GATES. DO NOT ATTEMPT TO CLIMB DOWN MAST.**

#### **CAUTION**

**THE MAST IS PRE-LOADED FOR UPWARD MOVEMENT BY THE INTERNAL PRESSURIZED GAS CYLINDER, NEVER ATTEMPT TO ENGAGE THE EMERGENCY LOWERING TOOL WITHOUT AN OCCUPANT IN THE PLATFORM.**

To lower the platform in the event of the operator being incapacitated (unable to operate the flywheel handle in the basket):

1. Locate emergency lowering tool on chassis, remove from machine. (See Figure 4-1. and Figure 4-2.)
2. Stand to side of machine (1), attach 'hook' end of emergency lowering tool to flywheel handle in platform (2), releasing handle (3) turn the flywheel counter-clockwise (4), to bring platform down. (See Figure 4-3.)

- 3. Keep clear of platform as it descends.
- 4. Depending on the height of the elevated platform, it may be necessary to extend the shaft of the lowering tool.
- 5. Turn the shaft lock counter-clockwise to extend and retract the lowering tool shaft, and clockwise to lock to the desired position.

**NOTE:** Step 4 & 5 are applicable only for EcoLift 70.

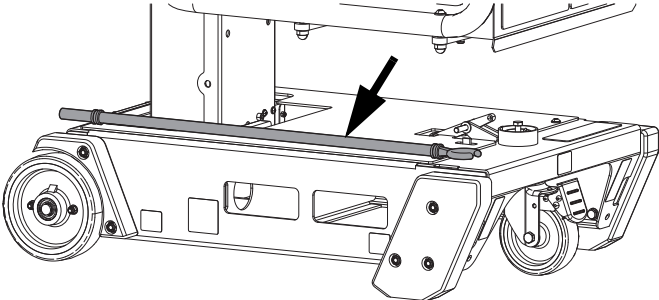

**Figure 4-1. Emergency Lowering Tool (EcoLift 50)**

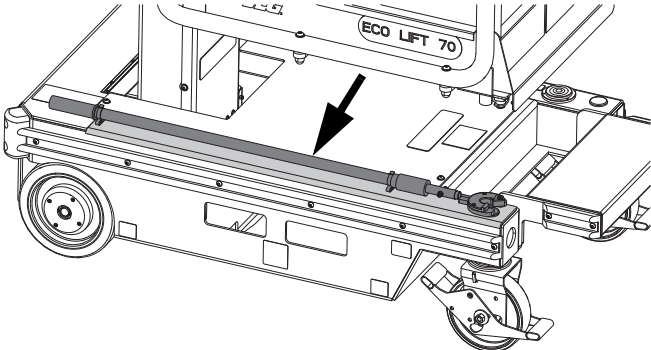

**Figure 4-2. Emergency Lowering Tool (EcoLift 70)**

## SECTION 4 - EMERGENCY PROCEDURES

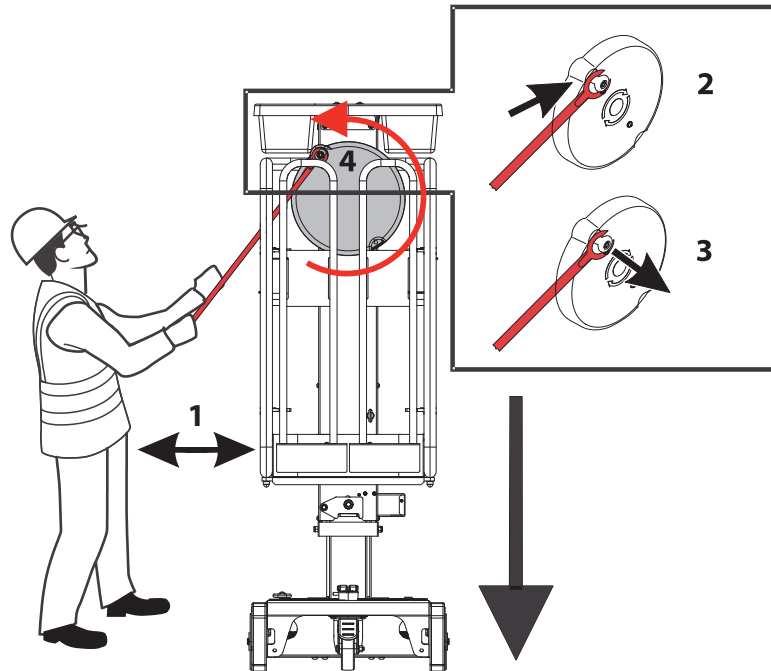

Figure 4-3. Emergency Lowering (Ecolift 50 and Ecolift 70)

**SECTION 5. GENERAL SPECIFICATIONS**

**Other Publications Available Specific to this Machine:**

Illustrated Parts Manual

ANSI..... 3121743

Service and Maintenance Manual

ANSI..... 3121748

## SECTION 5 - GENERAL SPECIFICATIONS

### 5.1 GENERAL SPECIFICATIONS

#### Machine Specifications

**Table 5-1. Machine Specifications**

DESCRIPTION	EcoLift 50	EcoLift 70
Maximum Working Height	11.5 ft. (3.50 m)	14 ft. (4.20 m)
Maximum Platform Height	4.9 ft. (1.50 m)	7.21 ft. (2.20 m)
Platform Dimensions	28.3 in. (L) x 23.6 in. (W) (720 mm (L) x 600 mm (W))	33.4 in. (L) x 25.3 in. (W) (850 mm (L) x 644 mm (W))
Working Footprint	38.8 in. x 28.3 in. (985 mm x 700 mm)	50.3 in. x 29.1 in. (1280 mm x 740 mm)
Max. Platform Capacity (Platform and Tool Tray Combined)	330 lb. (150 kg) (1 person + tools)	
Max. Tool Tray Capacity	33 lb. (15 kg)	
Maximum Manual Side Force	45 Lb. (200 N)	
Maximum Gradient For Operation	0 degrees	

**Table 5-1. Machine Specifications**

DESCRIPTION	EcoLift 50	EcoLift 70
Maximum Wind Force	Indoor use only	
Maximum Wheel Load	260 lb. (118 kg)	320 lb. (145 kg)
Maximum Ground Bearing Pressure	168 psi (11.81 kg/cm <sup>2</sup> )	171 psi (12 kg/cm <sup>2</sup> )

**Table 5-2. Machine Dimensions**

DESCRIPTION	EcoLift 50	EcoLift 70
Length	38.8 in. (985mm)	50.3 in. (1280 mm)
Width	28.3 in. (700mm)	29.1 in. (740mm)
Height	61 in. (1550mm)	76.77 in. (1950mm)
Weight	397 lb. (180kg)	672 lb. (305 kg)



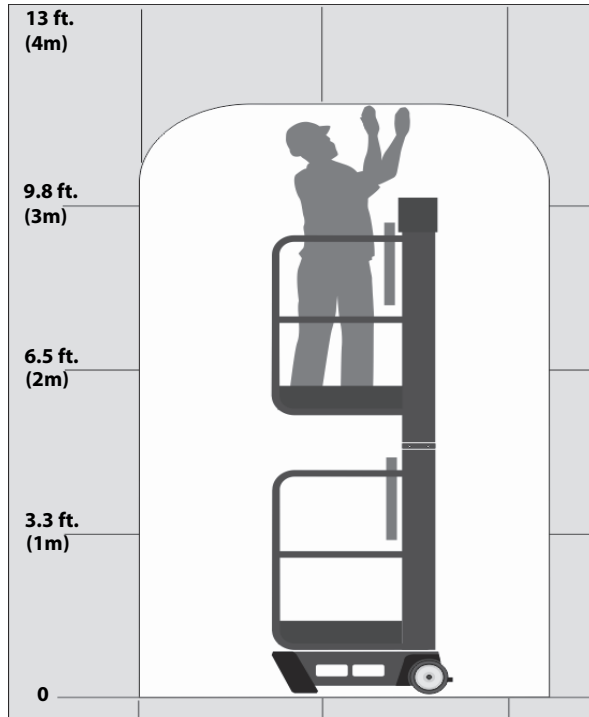

**Figure 5-1. Operating Specifications (EcoLift 50)**

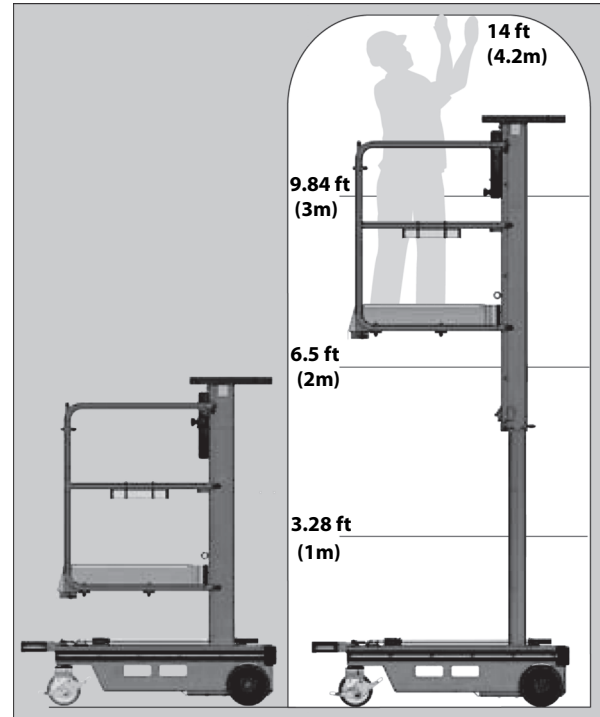

**Figure 5-2. Operating Specifications (EcoLift 70)**









An Oshkosh Corporation Company

# TRANSFER OF OWNERSHIP

## To Product Owner:

If you now own but ARE NOT the original purchaser of the product covered by this manual, we would like to know who you are. For the purpose of receiving safety-related bulletins, it is very important to keep JLG Industries, Inc. updated with the current ownership of all JLG products. JLG maintains owner information for each JLG product and uses this information in cases where owner notification is necessary.

Please use this form to provide JLG with updated information with regard to the current ownership of JLG products. Please return completed form to the JLG Product Safety & Reliability Department via facsimile or mail to address as specified below.

Thank You,

Product Safety & Reliability Department

*JLG Industries, Inc.*

13224 Fountainhead Plaza  
Hagerstown, MD 21742  
USA

Telephone: +1-717-485-6591  
Fax: +1-301-745-3713

**NOTE:** Leased or rented units should not be included on this form.

Mfg. Model: \_\_\_\_\_

Serial Number: \_\_\_\_\_

Previous Owner: \_\_\_\_\_

Address: \_\_\_\_\_

Country: \_\_\_\_\_ Telephone: (\_\_\_\_) \_\_\_\_\_

Date of Transfer: \_\_\_\_\_

Current Owner: \_\_\_\_\_

Address: \_\_\_\_\_

Country: \_\_\_\_\_ Telephone: (\_\_\_\_) \_\_\_\_\_

Who in your organization should we notify?

Name: \_\_\_\_\_

Title: \_\_\_\_\_







An Oshkosh Corporation Company

**JLG Industries, Inc.**  
1 JLG Drive  
McConnellsburg PA. 17233-9533  
USA

(717) 485-5161 (Corporate)  
 (800) 544-5438 (Service)  
 (717) 485-6417  
**www.jlg.com**



**3121740**

## JLG Worldwide Locations

JLG Industries  
358 Park Road  
Regents Park  
NSW 2143  
Sydney 2143  
Australia  
 +6 (12) 87186300  
 +6 (12) 65813058  
Email: techservicesauc@jlg.com

JLG Ground Support Oude  
Bundurs 1034  
Breitwaterstraat 12A  
3630 Maasmechelen  
Belgium  
 +32 (0) 89 84 82 26  
Email: emeaservice@jlg.com

JLG Latino Americana LTDA  
Rua Antonia Martins Luiz, 580  
Distrito Industrial Joao Narezzi  
Indiaatuba-SP 13347-404  
Brasil  
 +55 (19) 3936 7664 (Parts)  
 +55(19)3936 9049 (Service)  
Email: comercialpecas@jlg.com  
Email: servicios@jlg.com

Oshkosh-JLG (Tianjin) Equipment  
Technology LTD  
Shanghai Branch  
No 465 Xiao Nan Road  
Feng Xian District  
Shanghai 201204  
China  
 +86 (21) 800 819 0050

JLG Industries Dubai  
Jafza View  
PO Box 262728, LB 19  
20th Floor, Office 05  
Jebel Ali, Dubai  
 +971 (0) 4 884 1131  
 +971 (0) 4 884 7683  
Email: emeaservice@jlg.com

JLG France SAS  
Z.I. Guillaume Mon Amy  
30204 Fauillet  
47400 Tonniens  
France  
 +33 (0) 553 84 85 86  
 +33 (0) 553 84 85 74  
Email: pieces@jlg.com

JLG Deutschland GmbH  
Max Planck Str. 21  
27721 Ritterhude - Ihlpohl  
Germany  
 +49 (0) 421 69350-0  
 +49 (0) 421 69350-45  
Email:german-parts@jlg.com

JLG Equipment Services Ltd.  
Rm 1107 Landmark North  
39 Lung Sum Avenue  
Sheung Shui N. T.  
Hong Kong  
 +(852) 2639 5783  
 +(852) 2639 5797

JLG Industries (Italia) S.R.L.  
Via Po. 22  
20010 Pregnana Milanese (MI)  
Italy  
 +39 (0) 2 9359 5210  
 +39 (0) 2 9359 5211  
Email: ricambi@jlg.com

JLG EMEA B.V.  
Polaris Avenue 63  
2132 JH Hoofdorf  
The Netherlands  
 +31 (0) 23 565 5665  
Email: emeaservice@jlg.com

JLG NZ Access Equipment & Services  
2B Fisher Crescent  
Mt Wellington 1060  
Auckland, New Zealand  
 +6 (12) 87186300  
 +6 (12) 65813058  
Email:techservicesaus@jlg.com

JLG Industries  
Vahutinskoe shosse 24b.  
Khimki  
Moscow Region 141400  
Russia Federation  
 +7 (499) 922 06 99  
 +7 (499) 922 06 99

Oshkosh-JLG Singapore Technology  
Equipment Pte Ltd.  
35 Tuas Avenue 2  
Jurong Industrial Estate  
Singapore 639454  
 +65 6591 9030  
 +65 6591 9045  
Email: SEA@jlg.com

JLG Iberica S.L.  
Trapadella, 2  
Pol. Ind. Castellbisbal Sur  
08755 Castellbisbal Barcelona  
Spain  
 +34 (0) 93 772 47 00  
 +34 (0) 93 771 1762  
Email:parts\_iberica@jlg.com

JLG Sverige AB  
Enkopingsvagen 150  
176 27 Jarfalla  
Sweden  
 +46 (0) 8 506 595 00  
 +46 (0) 8 506 595 27  
Email: nordicsupport@jlg.com

JLG Industries (UK) Ltd.  
Bentley House  
Bentley Avenue  
Middleton, Greater Manchester  
M24 2GP  
United Kingdom  
 +44 (0) 161 654 1000  
 +44 (0) 161 654 1003  
Email: ukparts@jlg.com