



Mark V (Model 500) Saw Guard System Retrofit Kit 505875

Introduction

The Saw Guard System mounts on the Shopsmith Mark V (Model 500) and provides a physical barrier between you and the blade both above and underneath the worktable no matter what height or angle you adjust the worktable.

Some of the features of the saw guard system are:

- The upper guard is mounted on a splitter that keeps the saw kerf from closing and binding the blade. On this splitter are two anti-kickback pawls that help keep the blade from kicking the stock back towards you.
- The upper guard is clear so that you can see the blade. There's a removable plastic insert that can be easily cleaned or replaced so that you can keep your line of sight clear.
- The lower saw guard has a spring-loaded side that automatically adjusts to the height of the table and a dust chute for attaching a hose from your dust collection system.
- The tie bar shield has a second dust chute for attaching a second hose from your dust collection system for high efficiency dust collection.

Modify the Tie Bar

Before you install this saw guard system on your Mark V, you'll have to cut off a portion of the tie bar, and drill and tap four holes in the tie bar.

Tools and Supplies Required: 5/32", 3/16" Allen wrenches; hand-held electric drill; #7 (.201) and #21 (.159) drill bits; taps — 1/4"-20 and #10-32; tap handle or Mark V drill chuck; scratch awl; center punch; medium blade screwdriver; straightedge; hacksaw (24 teeth max.); coarse, double-cut metal file; flat file; light-weight oil; silicone.

WARNING

Turn the speed dial to 'Slow', turn off and unplug the Mark V.

1. Remove the old upper and lower saw guards from your Mark V. Discard these parts.

2. Cut off a portion of Mark V tie bar.

a. Set the worktable to the '0' position. Then remove the worktable from the carriage and place the top face down on your workbench.

b. Place the template over both table tubes with the words "THIS SIDE UP" facing up and the angled slot at the outfeed tube. (See Figure 1.)

c. Use a scratch awl to scribe a line through the template slot and onto the tube boss. Remove the template.

d. Securely clamp the worktable to your workbench in such a way that you can easily align yourself and the hacksaw with the scribed line. Be sure that the hacksaw frame will not interfere with any part of the table or tie bar.

CAUTION

The cut must be vertical (parallel to the support tube) and not tapered in toward the tube. If the cut is tapered, the tie bar will be weakened.

e. Use a hacksaw with a sharp blade to cut vertically through the tube boss but not into the horizontal part of the tie bar. (See Figure 2.)

f. After the cut is made, file the sawn surface with a coarse, double-cut, metal file. Apply Shopsmith touch-up paint if desired.

3. Drill and tap holes in the tie bar.

a. Hold the mounting block (17) against the outfeed end of the tie bar and slide it up until it fits snug against the tie bar shoulder. It should not ride up on the shoulder. Align the face of the mounting block parallel with the rear edge of the worktable by sighting along the face of the mounting block and the edge of the table.

b. Hold the mounting block firmly in place. Use a scratch awl to mark the two screw positions onto the tie

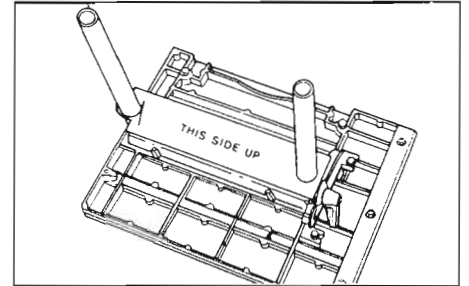

Figure 1. Positioning the template.

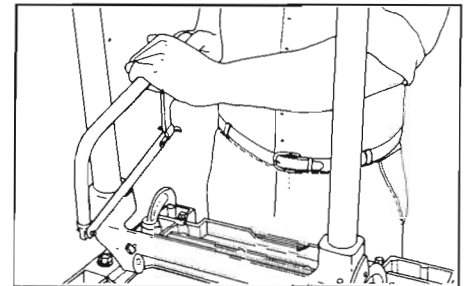

Figure 2. Cutting the tube boss.

bar. Remove the mounting block and center punch the hole positions.

c. Using a hand drill with #7 drill bit, drill the two through holes. Keep the bit horizontal. Do not drill at an angle. Drill the lower hole only through to the center of the tube.

d. Tap the holes using a 1/4"-20 tap. Apply a generous coat of light-weight oil to the drilled holes and tap. Be sure the tap is aligned with the holes. After the tap has penetrated past the tapered end, use a half turn forward/quarter turn back motion to clear chips and prevent the tap from binding. Do not force the tap through the tie bar. Taps are brittle and will break if forced. Keep the tap well lubricated at all times.

e. Hold the tie bar shield (20) centered against the tie bar. Center punch the two hole positions in the center of the tie bar slots. Remove the shield. Use a #21 bit to drill the holes. Keep the bit perpendicular to the table supports. Tap the holes using a #10-32 tap in the same manner as above. When done tapping, wipe off all the oil from the tie bar. Install the two thumbscrews (21) into the holes and position the heads horizontal.

f. Remount the worktable on the Mark V. Tighten the table height lock. Mount the mounting block (17) onto the tie bar using two screws (19).

Installation

1. Position the headstock so that you can reach the main spindle. **Tighten the quill lock.**

2. Mount the lower saw guard on the quill so that the collar on the guard butts up against the stop collar on the quill. With a $5/32$ " Allen wrench, tighten the two screws (27) on the collar. (See Figure 3.) Tighten each screw equally.

3. Mount the saw blade and arbor onto the main spindle. Secure the setscrew properly against the flat of the spindle by rocking the Allen wrench as you tighten the setscrew.

4. Mount the tie bar shield (20) over the two thumbscrews on the tie bar. Tighten the thumbscrews.

5. Raise the worktable as high as it will go. Slide the carriage toward the headstock until it butts up against the rubber spacer. Lower the worktable. If the tie bar shield interferes with the lower guard, loosen the thumbscrews and adjust the tie bar shield accordingly. Retighten the thumbscrews. **Secure the table height and carriage locks.** Set the table to the "0" position.

6. Install the upper saw guard by sliding the upper guard from left to right into the slots in the mounting block (17).

7. Align the splitter. Raise the upper guard and lay a straightedge on the worktable so that it touches the blade and the splitter (8). Move the upper guard to the right or left, as needed, so the straightedge rests flush against both the blade and the splitter. (See Figure 4.) Then install and tighten the locking knob (18). The splitter **must** be aligned every time you mount the upper guard or adjust the saw blade position using the quill.

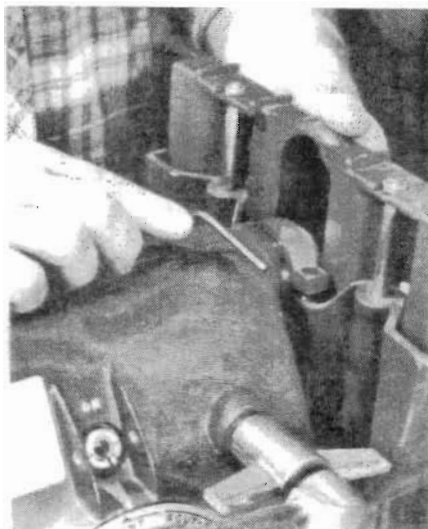

Figure 3. Place the lower saw guard on the quill, then tighten the Allen screws on the saw guard collar.

NOTE

After you've aligned the splitter, you can make a simple template to help simplify this task in the future. (See Figure 5.) Rip part way up the middle of the stock, about 14" or until the back of the stock just clears the back of the splitter. Turn off the machine, wait for the blade to stop and then remove the stock. Use the kerf in the stock to align the splitter each time you mount the upper guard or to adjust the blade position using the quill.

8. Check all locks. The table tilt, carriage, table height, headstock and quill locks should be secure.

9. Attach the two elbows to the outer guard (24) and the tie bar shield (20). Then connect the dust collection hose(s).

For high efficiency dust collection, connect one hose from the Shopsmith Dust Collector or other dust collection system to the elbow on the outer guard. Connect a second hose to the elbow on the tie bar shield. If your dust collection system



Figure 4. Using a straightedge, move the upper saw guard to the right or left until the splitter is directly in line with the saw blade.

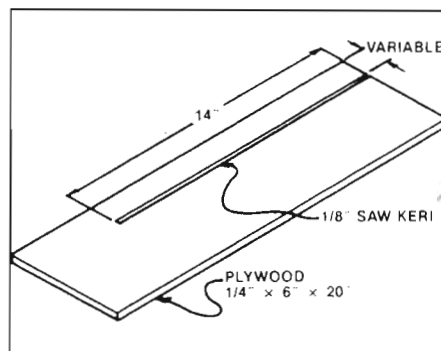

Figure 5. Make a template to quickly align the splitter with the blade.

has only one hose, connect it to the outer guard elbow. You'll get adequate dust collection using just one hose.

Operations

Table saw accidents are most often caused by kickbacks. Kickback is the ejection of the stock from the saw back toward the operator. Kickback causes loss of control and your hand could be thrown into the blade or you could be hit by flying stock. Never stand directly in the line of rotation of a moving blade. This lessens your chances of being hit by flying stock if a kickback occurs. Kickback is caused by:

- the kerf of the stock closing up and pinching the rear of the saw blade.

- the stock wedging between the rip fence and the rear of the saw blade.
- the stock binding against the sides of the blade as it passes through the stock.

To help prevent kickbacks and other table saw accidents, read and follow the safety information below before operating the Mark V with the saw guard system installed.

WARNING

- Follow the Mark V Owners Manual.
- Keep the upper and lower saw guards in place whenever you operate the Mark V in the table saw mode. The only exception is when you saw part way through stock — such as when cutting a rabbet or groove, or when using the dado or molder accessory. Then you must remove the upper guard. However, KEEP the lower guard in place and work with extreme caution. Use safety devices to move the stock past the unguarded blade. NEVER place your hands over the blade even if the blade is covered by the stock.
- Position the saw blade so it doesn't protrude more than 1/4" above the stock.
- Prevent kickback: Never make freehand cuts; Never reach over the saw blade while the machine is running; Keep blades sharp, properly set and free of pitch; Avoid cutting wet or pitchy wood; When crosscutting always use the miter gauge with safety grip. If you use the rip fence with the miter gauge, always clamp a stop block to the rip fence; When ripping, always

use the rip fence and make sure that it is parallel to the blade; When beveling, always mount the rip fence or the miter gauge on the downward side of the worktable. Always cut with the smooth, hard surface of the stock against the worktable; Make sure that the splitter on the saw guard is properly aligned with the saw blade and the pawls are sharp.

- Do not rip large sheets of plywood or similar materials by yourself. Get at least one helper.
- Do not use saw blades larger than 10" in diameter because they won't fit in the guards.
- Always use the proper table insert for the operation.
- Position the elbows so that the stock will not hit them or the dust collection hoses when the table is tilted to make 45° bevel cuts.
- Use ONLY the 5/8" saw arbor (555118) to mount 10" blades with 5/8" arbor holes. DO NOT use the 5/8" molder/dado arbor (also known as the universal arbor).

Also, remember when setting the table tilt, be sure to install the upper guard first; otherwise after the table tilt is set, the upper guard cannot be installed. Also, when using the Mark V in the horizontal boring mode, remove the tie bar shield. After using the molder or dado accessory, be sure to raise the table to a height that clears not only the accessory, but also the lower guard before moving the worktable.

Maintenance

The saw guard system requires a minimum of maintenance. Perform the following as needed:

- Brush and blow away the sawdust that accumulates in the upper and lower guards.
- Wax and buff the splitter with paste furniture or paste floor wax. This will make your stock slide easier and keep resin from sticking to the splitter. Do not wax plastic parts.
- Keep the anti-kickback pawls sharp. The pawls prevent kickbacks. Use a file to sharpen the pawls.
- If the lower guard spring mechanism responds slowly, apply silicone to the rods and the sliding deflectors in the lower guard.

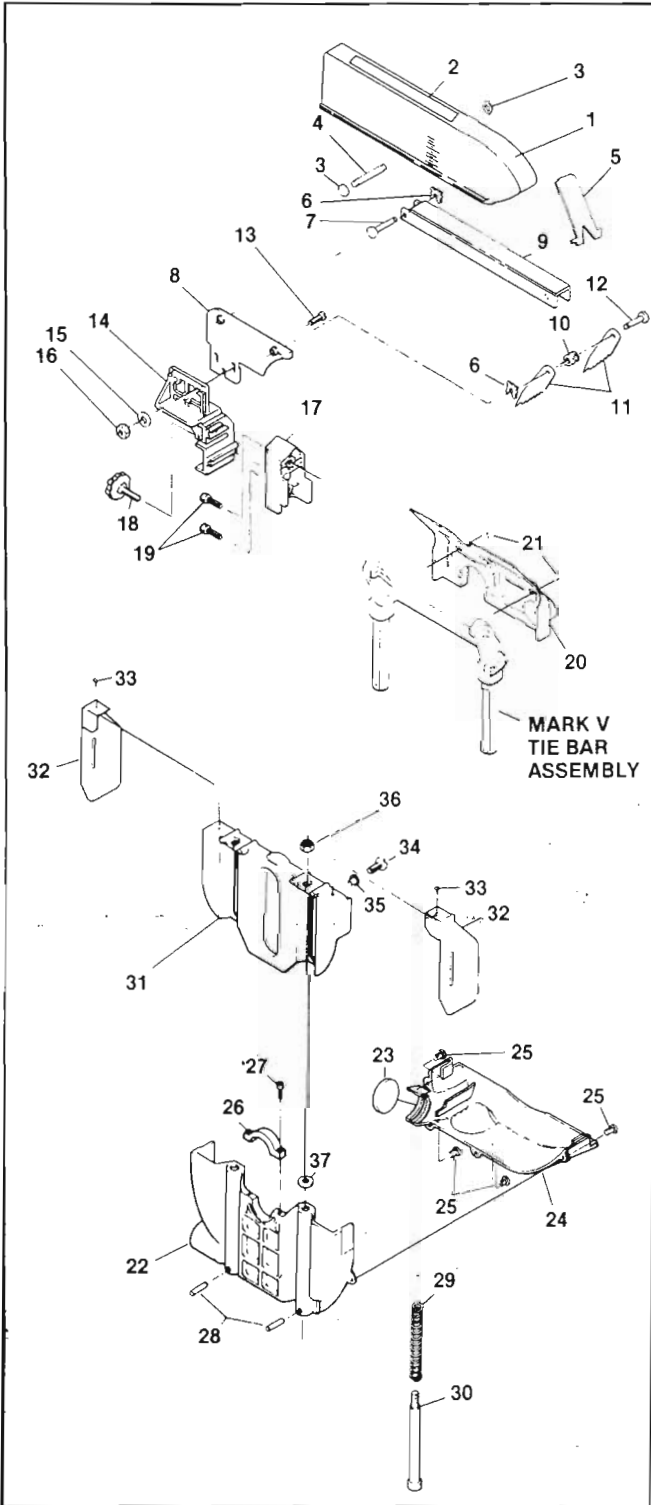

Parts List

Ref. No.	Part No.	Description	Qty.
—	513483	Upper Saw Guard Assembly (Incl. 1-16)	
1	513835	Upper Saw Guard and Insert (Incl. 2-4)	1
2	514595	Label	1
3	513486	Speed Nut	2
4	513485	Hinge Pin	1
5	505975	Upper Saw Guard Insert (5 per pkg. when ordered separately)	1
—	513831	Splitter Assembly (Incl. 6-12)	
6	513524	Special Split Washer	2
7	514029	Rear Hinge Pin	1
8	513493	Splitter	1
9	513718	Top Support Link	1
10	513504	Torsion Spring	1
11	513494	Anti-Kickback Pawl	2
12	514028	Front Hinge Pin	1
13	513490	Buttonhead Screw	3
14	513499	Support Bracket	1
15	120392	Flat Washer	3
16	120375	Hex Nut	3
17	513500	Mounting Block	1
18	513496	Locking Knob	1
19	513201	Hex Socket Screw	2
20	515288	Tie Bar Shield	1
21	513495	Thumbscrew	2
—	513484	Lower Saw Guard Assembly (Incl. 22-37)	
—	515290	Lower Saw Guard (Incl. 22-25)	
22	513515	Inner Guard, Bottom	1
23	515263	Plug	1
24	514877	Outer Guard	1
25	514832	Pan Head Screw	4
26	513492	Retainer	1
27	513513	Screw	2
28	513512	Spring Pin	2
29	513511	Spring	2
30	513507	Retainer Rod	2
31	513506	Inner Guard, Top	1
32	515370	Deflector	2
33	514881	Self-Tapping Screw	2
34	513514	Truss Head Screw	2
35	513642	Special Shoulder Washer	2
36	513585	Hex Nut	2
37	513865	Flat Washer	2
—	514521	Elbow, 2-1/2" Dia.	2
—	PL-5198	Template	1

Shopsmith Inc.

6530 Poe Avenue
Dayton, Ohio 45414

© Copyright 1987 Shopsmith, Inc. All rights reserved.
Shopsmith is a registered trademark of Shopsmith, Inc.

845202 Rev 2/88
Printed in U.S.A



Information Update for the Mark V Model 500 Saw Guard System Retrofit Kit

The following information updates the product literature (PL-5202) for the Saw Guard System Retrofit Kit for the Shopsmith Mark V Model 500:

• Page 1, Tools and Supplies Required:

Delete the #21 (.159) drill bit, and delete the #10-32 tap. Neither are used.

Instead, on **page 1, Step 3e** where it calls for the above bit or tap, use the already-noted **#7** drill bit, and the already-noted **1/4"-20** tap.

• Page 1, Step 3e and page 2, Step 5 (Installation section):

Delete references to thumbscrews (Ref.#21).

They have been replaced by button head socket screws (Part No. 517829). Use a 5/32" Allen wrench to tighten or loosen these socket screws.

• Parts List, Ref# 21:

NEW		
Part No.	Description	Qty.
517829	Button head socket screw	2

Shopsmith Inc.

3931 Image Drive
Dayton, Ohio 45414

Note: If you have further questions or need help, visit the Shopsmith Store in your area, or call Customer Service: Toll Free 1-800-762-7555 (in Canada, 1-800-268-3998).

TL-7048 5/92
Printed in the U.S.A.