

Cal Offroad

4X4 SUSPENSION



PRODUCT GUIDE



CalOffroad

With decades of experience, CalOffroad stands at the forefront of 4x4 and offroad suspension systems, offering the highest quality and best performing products and the best customer service available in the market.



Our strong roots in offroad vehicles date back to the early '80s, forged through collaborations with industry leaders in the USA and extensive testing in iconic locations like Moab, Utah, and Colorado. With a family history deeply intertwined with Australia's remote and outback destinations, our offroad testing facility ensures cutting-edge products, continuous refinement and extensive local development.

Our company has a rich heritage as a 4x4 enthusiast-driven product supplier. We embrace a new era of performance with our comprehensive range of suspension components. CalOffroad redefines the offroad experience - our suspension range, lift kits and accessories deliver unparalleled handling, performance and control. All of our products are meticulously tuned and tested by our expert development team.

CalOffroad operates on three core principles, Performance, Innovation, and People. We challenge boundaries through innovation, always pushing the limits of what's possible to the best solution available for our customers. Our premium products and a strong connection to 4x4 enthusiasts allows our customers to confidently explore any on and offroad terrain. Through a commitment to innovation and continuous improvement, we aim to be the first choice for 4x4 suspension components in Australia and worldwide.

At the heart of CalOffroad is a dedication to our customers and communities. We are focused on customer satisfaction and we offer best-in-class after-sales service and product support. Our award-winning products not only provide solutions to your 4x4 needs, they will elevate your 4x4 ability and performance.

Join us in the relentless pursuit of excellence, where CalOffroad transforms the impossible into the achievable, setting new standards in 4x4 suspension technology.



4 X 4 S U S P E N S I O N **PRODUCT** GUIDE





CalOffroad has strong roots with offroad trucks that began in the early 80's. Spending time in the USA with industry leaders enabled us to understand and acquire access to the latest in vehicle design and best offroad suspension technology.

CalOffroad develops and refines 4x4 suspension technology at our Snowy Mountains based testing facility and follows through with all products pushed to the limit at some of Australia's most punishing outback destinations. This thorough process allows us to create the most advanced 4x4 suspension components available in Australia and anywhere in the world.

CalOffroad has been developing and producing some of the world's most advanced 4x4 and offroad suspension systems for decades, providing the best quality and performance you can rely on. Our development team has tested and expertly tuned every product to uncover your vehicle's hidden performance, allowing you to head offroad confidently and discover how good your vehicle can be.

CalOffroad's complete line of hassle-free, bolt-on suspension components, including Coilover Struts, Shocks, Springs, Control arms and Steering stabilisers, are designed to maximise your 4x4 performance on and off the road. Our Lift Kits and Suspension ranges offer unmatched handling, performance, and control for your 4x4.

Discover the ride you've been looking for with CalOffroad's 4x4 suspension products.

WORLD LEADING BRANDS

CalOffroad

A passion for off-road travel and the development of 4x4 suspension products is what drives CalOffroad. For over 30 years, CalOffroad has been developing and producing the most advanced, high performing 4x4 and offroad suspension systems available in Australia and anywhere in the world.

Experience world-class suspension for your 4x4 with the CalOffroad Platinum and Nitro Pro series of 4x4 suspension.

Our products are developed, tested and refined in a private off-road testing facility right here in Australia.



At BILSTEIN, driving dynamics is a passion. Achieving the perfect driving behaviour and building the ideal shock absorber for your 4x4 is the motivation.

Even then, it was understood that tomorrow's driving experience counts more than yesterday's performance and that the next innovation is always more important than the last. BILSTEIN shape and enhance the present and future of 4x4 chassis engineering by enabling it with high quality suspension and underbody solutions.

CalOffroad is an authorised BILSTEIN offroad suspension distributor.



FOX Shocks are world renowned as a premium brand 4x4 off road and racing shocks.

For over three decades, FOX has been an industry leader in designing and developing extreme high-performance shock absorbers and racing suspension products for, 4x4s, utes, trucks, SUVs, ATVs, motorcycles and mountain bikes.

CalOffroad is an authorised Fox offroad suspension distributor and service centre.



SHOCK ABSORBER



CALOFFROAD NITRO PRO

Performance upgrade from original equipment

Tuned in Australia for local conditions

Low pressure Nitrogen gas

Double welded eyes & pins

Twin tube construction

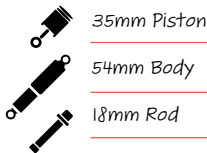

35mm Piston

54mm Body

18mm Rod

AUSTRALIAN DESIGN AND MANUFACTURE



BILSTEIN

Performance upgrade from original equipment

High pressure Nitrogen gas

Mono tube construction

Adjustable ride height



46mm Piston

52mm Body

18mm Rod

GERMAN DESIGN AND MANUFACTURE



CalOffroad
NITRO PRO

BILSTEIN



SELECTION



CALOFFROAD PLATINUM

High Performance upgrade

Tuned for Australian conditions

Mono tube construction

Adjustable ride height



46mm Piston



52mm Body



18mm Rod

AUSTRALIAN
DESIGN AND
GERMAN
MANUFACTURE



CalOffroad
PLATINUM



FOX PERFORMANCE

Race developed high performance upgrade

Mono tube construction

Aluminium body

Adjustable ride height

Serviceable



45mm Piston



50mm Body



16mm Rod

USA DESIGN AND
MANUFACTURE



FOX

SHOCK ABSORBERS, STRUTS AND COILOVERS





CALOFFROAD NITRO PRO SERIES

Embrace a new era of 4x4 performance with the CalOffroad Nitro Pro range of suspension. If you require a suspension upgrade, higher load carrying capacity, more comfort for touring, better 4x4 capability or a lift of up to 2 inches on your vehicle, The CalOffroad Nitro Pro range has you covered.

The Nitro Pro suspension range has been designed, engineered and manufactured in Australia.

The CalOffroad Nitro Pro series shocks are designed to deliver exceptional performance in on and off-road environments. With advanced features and meticulous design, these shocks provide unmatched performance, durability, and comfort for enthusiasts seeking quality suspension with direct fit application.

Each shock in the Nitro Pro series boasts a twin tube design that is cold drawn over a mandrel. This manufacturing process ensures the shocks possess high strength and precise diameter control. The result is a robust and reliable shock that can withstand the demands of rugged terrains.

Engineered with a larger oil capacity, Nitro Pro shocks can hold more oil for faster heat dissipation. This design enhancement allows for optimal performance over extended periods, even in the most challenging off-road adventures.

The shock is designed with a large internal bore and piston diameter to increased rebound damping. This innovative design allows for better control and a smoother ride over bumps and uneven surfaces.

The piston rods are induction hardened and hard chrome plated, making them incredibly robust. This level of durability ensures the shocks can handle heavy-duty tasks and the harshest of conditions.

Each Nitro Pro series shock is equipped with full-displaced valving, providing precise control over rebound and increased compression damping capabilities. This valving design improves control when load-carrying and towing.

Inside the shocks, a slip ring rod guide, Teflon impregnated bronze bearing and T-shaped slip ring work together to control damping forces and meter flow to the seal. This ensures optimal performance and a smooth ride in any environment.

To enhance performance and mitigate common issues like foaming and noise, all CalOffroad Nitro Pro series shocks are gas pressurised to 60 psi. This pressurisation reduces the chance of fade and allows for consistent performance in all conditions.

CalOffroad applies a 2-part epoxy paint coating to every Nitro Pro shock. This coating provides superior resistance against stone chips and corrosion, keeping the shocks in excellent condition.

Nitro Pro series shocks offer a plastic dirt shield made from Polypropylene material. This shield effectively safeguards the seal from dust and debris and reduces noise levels.



*Performance upgrade
from original equipment*

*Tuned in Australia for local
conditions*

Low pressure Nitrogen gas

Double welded eyes & pins

Twin tube construction

35mm Piston

54mm Body

18mm Rod



**AUSTRALIAN DESIGN
AND MANUFACTURE**



BILSTEIN B6 OFFROAD

For the most advanced Bilstein shock absorber solution for your 4x4, look no further than CalOffroad. CalOffroad works closely with BILSTEIN'S head engineers and ensure all shocks go through rigorous R&D testing to ensure that the CalOffroad supplied Bilstein shocks live up to their reputation for being the best in the world.

Using a mono-tube design, the BILSTEIN B6 OFFROAD shock absorber offers greater performance reserves and an extended service life, even when put through strenuous driving conditions, such as towing or off-road applications. You can expect optimum road adhesion and enhanced lane change stability in day-to-day applications as well as extreme situations thanks to BILSTEIN'S adjustable damper settings, both aspects that often leave a lot to be desired in large 4WDs.

Built in Germany to meet CalOffroad's stringent quality requirements, CalOffroad Platinum Bilstein Series Shock Absorbers feature proprietary valving and IFP (internal floating piston technology). This IFP separates high-pressure nitrogen gas from oil, eliminating shock fade and oil foaming.

Designed specifically to suit off-road vehicles, the BILSTEIN B6 Offroad gas-pressure shock absorber is the perfect suspension solution and has been tuned to suit the harshest or Australian 4x4 driving conditions. The BILSTEIN B6 off road shock absorber has been developed to reduce uncontrolled movements that are inherent in many 4x4 vehicles due to their high structure.

The vehicle-specific upper mounts include a rotating crush tube to allow for more wheel travel without causing shock bind. Both ends run a low-maintenance bush system that isolates road noise and vibration.

Extensive testing and fine tuning has been undertaken by Bilstein to ensure that fitting BILSTEIN B6 Offroad shock absorbers to your 4WD improves handling performance across all vehicle applications. Offering a higher load carrying capacity as well as a higher degree of vehicle control, the BILSTEIN B6 Offroad shock absorber increases 4WD capability across all driving conditions, from the black top to the off-road trails.

The CalOffroad Bilstein shocks can be used at stock height or lifted with both options finely tuned for specific vehicle applications. They provide a safer and more enjoyable driving experience, reducing fatigue during long hauls and smooth ride in any off road conditions.

CalOffroad offers a wide range of Bilstein suspension solutions, including strut, shock, coil-over, spring and leaf products individually or in kits and are complimented by the rest of the CalOffroad ancillary range to ensure you have all of the products you need to upgrade your 4x4 vehicle. All CalOffroad Bilstein products offer direct fit application to your vehicle.

BILSTEIN

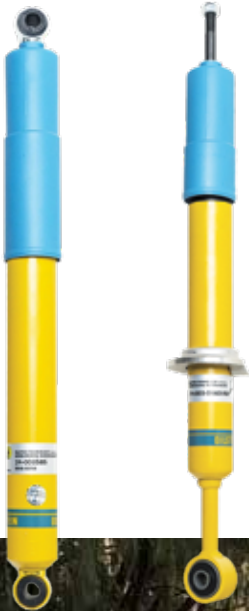

*Performance upgrade
from original equipment*

BILSTEIN monotube technology

High pressure Nitrogen gas

Individually fine-tuned

Height Adjustable & Long
Travel option



46mm Piston



52mm Body



18mm Rod



**GERMAN
DESIGN AND
MANUFACTURE**



CALOFFROAD PLATINUM SERIES

CalOffroad Platinum Series provides the ultimate off-road ride over any terrain. From potholes and corrugations to long stretches of gravel and dirt, this 4x4 suspension has been built with German technology and tuned especially for the harsh Australian conditions.

CalOffroad Platinum Series shocks have been developed through many years of testing and collaboration with Bilstein. CalOffroad Platinum Series offers ride height adjustment struts with race and performance style valving. CalOffroad Platinum Series are one of the world's most advanced shocks for off-road reliability, whether outback, touring, daily driving or racing.

The CalOffroad Platinum Series shock absorbers are equipped with exclusive valving technology and IFP (internal floating piston technology). This innovative IFP design effectively separates the high-pressure nitrogen gas from the oil, eradicating issues like shock fade and oil foaming. Additionally, these shock absorbers are completely rebuildable, adding to their longevity and potential for customisation.

Utilising monotube gas-pressure technology, CalOffroad Platinum shocks have been individually fine-tuned through rigorous road testing for maximum comfort and control, both on and off-road. The digressive valving instantly adapts to changing road surface conditions, providing a stable and comfortable ride.

To enhance the shock absorbers' performance even further, vehicle-specific upper mounts are included in the design. These mounts feature a rotating crush tube, enabling extended wheel travel without causing any shock bind.

All CalOffroad Platinum products are designed to offer the perfect combination of performance and reliability. Built to the highest quality standards, our shocks provide enhanced stability in everyday and extreme driving conditions. Featuring high gas pressure and a longer service life, the CalOffroad Platinum Series shocks perform when driving on-road, off-road or towing.

The CalOffroad Platinum shocks can be used at stock height or lifted with both options finely tuned for specific vehicle applications. They provide a safer and more enjoyable driving experience, reducing fatigue during long hauls and smooth ride in any off road conditions.

CalOffroad offers a wide range of suspension solutions, including strut, shock, coil-over, spring and leaf products individually or in kits and are complimented by the rest of the CalOffroad ancillary range to ensure you have all of the products you need to upgrade your 4x4 vehicle. All CalOffroad Platinum Series products offer direct fit application to your vehicle.

CalOffroad PLATINUM



High performance
upgrade from original
equipment

Tuned for Australian
conditions

Mono tube construction

Adjustable ride height
struts

Serviceable

-  46mm Piston
-  52mm Body
-  18mm Rod



AUSTRALIAN
DESIGN AND
GERMAN
MANUFACTURE



FOX PERFORMANCE SERIES

Move to premium off road performance with FOX 2.0 Performance series shocks through CalOffroad. FOX products are a premium off road solution that is designed to provide the ultimate ride in upgraded, lifted and specialised applications to a wide range of vehicles.

FOX shocks are built from high grade aluminium that will dissipate heat four times better than conventional materials. All FOX shocks are fully serviceable and resistant to corrosion and harsh environments. FOX Performance Series coil-overs will give you the damping performance, suspension control and proper spring rate to get the job done, whatever it is.

The use of high-quality materials in every FOX product ensures consistent and fade-resistant performance. FOX shocks contain race-developed main pistons and a true internal floating piston (IFP) that effectively separates gas and oil. The IFP eliminates oil aeration, allowing maximum performance from the factory-tuned precision valving.

The race-developed high-flow damping piston is matched with application-specific valving provides the Performance Series 2.0 IFP shock with a predictable ride quality capable of handling the roughest road conditions.

These durable components are torture-tested and race-proven, offering a lifetime of great rides.

The shocks utilise FOX's race-proven damping control to provide a comfortable on-road ride and predictable off-road handling in even the most challenging conditions.

Durability is a priority with all FOX shocks. A serviceable sealing pack and a beefy 5/8" shaft ensure longevity even in demanding situations. Additionally, the fully-rebuildable design allows for maintenance and adaptation through different internal tuning options to accommodate the ongoing changes of your vehicle.

FOX Performance Series shocks are designed to be used at stock height all the way up to 5.5" and will provide a safer and more enjoyable driving experience in any off road conditions.

CalOffroad offers a wide range of FOX suspension solutions, including strut, shock, coil-over, spring and leaf products individually or in kits and are complimented by the rest of the CalOffroad ancillary range to ensure you have all of the products you need to upgrade your 4x4 vehicle. All CalOffroad FOX products offer direct fit application to your vehicle.



Race developed high performance upgrade

Mono tube construction

Aluminium body

Adjustable ride height

Serviceable



 45mm Piston

 50mm Body

 16mm Rod

USA DESIGN AND
MANUFACTURE





LIFT KITS





LIFT KITS

Lift kits are available in 2" / 3" / 4"

ACCESSORY WEIGHT GUIDE.

VEHICLE PROTECTION	NUDGE BAR	10 - 15KG
	STEEL BAR	75 - 115KG
	ALLOY BAR	50 - 75KG
	SIDE BARS	15 - 20KG
	SIDE STEPS	35 - 45KG
	REAR BAR	45 - 75KG
WINCHES	WINCH 9500LB ROPE	35KG
	WINCH 9500LB STEEL	40KG
ROOF TRAY	STEEL	35 - 50KG
	ALLOY	20 - 25KG
CANOPY		75 - 85KG*
ROOF TOP TENT		55 - 60KG
UNDERBODY PROTECTION	FRONT	10 - 15KG
	SUMP	5 - 10KG
	TRANSMISSION	10 - 15KG
	TRANSFER	5 - 10KG
ADDITIONAL ACCESSORIES	AWNING	15KG
	RECOVERY JACK	20KG
	RECOVERY KIT	20KG
	DRIVING LIGHT 220MM	3KG
	SECOND BATTERY	30KG
	TOOL BOX 1200X500X700 ALLOY (EMPTY)	30KG
	80L FRIDGE (EMPTY)	30KG
	WAGON - REAR TYRE CARRIER (NO TYRE)	80KG

SPRING RATE OPTIONS



Light Duty.....0 to 100 KG



Medium Duty100 to 300 KG



Heavy Duty300 to 500 KG



Extra Heavy Duty..600 KG Plus



*Weight capacity & guide for illustration purposes only, weights are an approximation.

†CalOffroad recommends contacting your state registration department or certified engineer for compliance requirements when upgrading your vehicle.

CALOFFROAD NITRO PRO TOURING 0" – 2" LIFT

The spring and shock absorber rates of the Nitro Pro kit have been engineered to enhance your ride comfort, minimise body roll, and improve overall stability. The Nitro Pro kit is uniquely designed to upgrade your original 4x4 suspension, offering up to 2 inches of lift options, all while improving your vehicle's load-carrying capability.

COMPATIBILITY:

The Nitro Pro kit is perfect for vehicles used for work, commuting, long-distance trips and off-road adventures. It's tailored to meet the needs of carrying slightly heavier loads or the fitment of accessories, including roof and bike racks, bull bars, winches, cargo and storage systems.



CALOFFROAD PLATINUM TOURING 1" – 3" LIFT

The Platinum touring lift kit is developed for those seeking improved offroad performance with an increase in ride height up to 3", allowing fitment of larger wheels and tyres, improved articulation, and enhanced offroad and load-carrying capabilities, all while improving stability and reducing body roll ensuring optimal ride comfort. The kits are designed to improve vehicle braking and steering capability in off-road situations.

COMPATIBILITY:

The Platinum kit is perfect for towing or carrying heavy loads and enjoying weekends in the bush. This kit suits vehicles carrying heavier loads or filled with accessories, including roof and bike racks, bull bars, winches, cargo and storage systems.





FOX 4X4 LIFT KIT & TOUR PACK 2" – 3" LIFT

Developed using Fox Suspension's offroad racing experience, CalOffroad has designed these kits to suit Australian vehicles and conditions. The spring and shock combinations are selected to significantly improve your vehicle's ground clearance and suspension travel, increasing vehicle stability across all terrains. The kits improve the ability of the wheels to maintain contact with the ground on uneven surfaces, increasing the vehicle's performance in offroad conditions. The increased ride height ensures 4x4 enthusiasts improved capability when negotiating extreme terrain.

COMPATIBILITY:

The Fox Kit is the perfect upgrade for those wanting to get the most out of their ride on and off-road. Increased ride height allows fitment of larger wheel and tyre combinations and improved load carrying and towing capabilities.

The Fox lift kits enhance your vehicle performance when equipped with accessories like bullbars, bash plates, roof racks, spare wheel carries, toolboxes and storage systems.



SUSPENSION COMPONENTS

COMPONENTS



ON



Coil Springs

CalOffroad

A pivotal component of the 4WD suspension system is the coil springs. They are crucial for supporting the vehicle's weight and dampening shocks from road bumps and maintaining the vehicle's level on uneven terrain.

CalOffroad Platinum and Nitro Pro Series coil springs are developed and manufactured in Australia using high-grade Australian-made steel.

CalOffroad utilises the latest tapered wire technology that allows us to tune a rebound rate into the coil, assisting the shock for a less aggressive rebound and less shock fade under extreme conditions.

All CalOffroad coil designs are dyno tested to ensure the coil rate is tuned to match the shock valving, achieving the smoothest possible ride.

CalOffroad coil springs are a must-have if you are installing a lift kit or if your 4x4 is carrying additional weight and needs to reduce compression and maintain its desired height and stance.



- 1000°C Hot Rolled,
- Hardened And Tempered
- Shot Peened To Ensure Maximum Strength And Minimise Fatigue
- Load Tested To Eliminate Sag
- Long Lasting Silver Epoxy Powder Coated Finish.





Leaf Springs

CalOffroad Leaf Springs are meticulously designed, engineered, and produced in Australia, adhering to the highest quality standards to guarantee a comfortable ride both on and off-road.

CalOffroad leaf springs feature exclusive wear pads positioned between each leaf, significantly minimising vibration and road noise to enhance the overall ride comfort.

Unlike conventional leaf springs prone to issues such as squeaking and rubbing due to leaf-on-leaf contact, CalOffroad has effectively addressed these concerns with our specialised wear pads, preventing direct contact between the leaves.

Our leaf spring packs are available with various weight options, allowing you to customise your setup based on specific needs, whether it's carrying no load, work tools, or embarking on a desert trip.

CalOffroad shackles are meticulously engineered to the highest standards, ensuring the longevity of your 4x4 by offering a convenient replacement for original shackles with the inclusion of greaseable pins.

These top-tier greaseable pins facilitate easier and more efficient re-lubrication of the bush. The greasing point consists of an easily accessible grease nipple, reducing both cost and time during disassembly and service.

Essential for vehicles facing rugged environments, CalOffroad greaseable shackles safeguard the bush against premature wear, dust, and dirt infiltration, elevating the overall reliability and performance of your ride, enabling you to conquer off-road terrain with confidence.

CalOffroad Extended Greaseable Shackles go beyond merely protecting your bushes from premature wear; they also enhance your vehicle's flexibility and provide a rear lift for your 4x4. This presents a simple and cost-effective alternative to a suspension lift. Featuring high-grade greaseable pins, these shackles streamline the service process of your 4x4 suspension.





Australian designed.
Manufactured From High
Strength Spring Steel
increases strength &
durability

Graphite Coated
Reduces Friction For
Supple Performance.

Zinc coated insert to
increase bush life and
enhance load distribution

Various load ratings
available to suit your
vehicle & application



Coated with premium
finish to reduce friction
and increase performance

Wear pads between each leaf
to reduce vibration & noise



UPPER CONTROL ARMS

When a 4x4 suspension lift kit is installed, it displaces the original suspension caster and camber specifications beyond acceptable limits. This results in the loss of caster, leading to vague steering and the introduction of positive camber, which contributes to uneven and accelerated tyre wear.

CalOffroad Upper Control arm technology provides bolt-on solutions for your lifted 4x4 to correct the wheel position and eliminate misalignment.

CalOffroad's range of upper control arms, includes built-in Caster and Camber adjustment on some models, ensures your wheels stay straight and narrow and enhances your vehicle's stability and handling. This technology corrects the wheel alignment, reducing tyre wear and improving your off-road driving experience.

They are designed and tested on Australian terrain, forged from high-grade materials and manufactured with the accuracy to be bolt-on replacements of original equipment. CalOffroad's control arms go beyond correcting your alignment. They are designed to maximise tyre-to-arm clearance and increase chassis space clearances to ensure a hassle-free off-road adventure.

To complement this, wheel travel is increased with heavy-duty, high-angle, greaseable ball joints.

For an added layer of durability, all CalOffroad Upper Control Arms are coated with a double-layer shield to protect against corrosion, ensuring your arms resist all the elements.

Low noise, long life original equipment style rubber bushes are built into our upper control arms. They're not just quiet, they're maintenance-free which adds an extra layer of comfort to your ride.



RADIUS ARMS

CalOffroad's innovative radius arm design enables a host of benefits to your off-road experience. The increased clearance to the steering track rod ensures improved maneuverability and responsiveness.

These radius arms also provide superior ground clearance compared to other brands, a valuable advantage when navigating through challenging terrains like mud, sand, or rocks.

CalOffroad radius arms are crafted with a high grade chromoly through a special forging technique. These radius arms exhibit exceptional strength of 1.5 times that of original equipment radius arms while adding a mere 700 grams over the original equipment product.

The CalOffroad radius arms not only offer durability but also extend by 15mm to enhance wheel travel and stability. This extension also aids in correcting the wheelbase length.

Another feature of the CalOffroad radius arms is the built-in caster correction that ensures precise steering and improved handling. Rigorous testing has been conducted to ensure these radius arms are capable of supporting the heaviest GVM upgrades available in Australia.

The inclusion of Australian made rubber bushes adds another layer of quality and performance. CalOffroad's radius arms a reliable and robust choice for off-road enthusiasts seeking top-notch performance and durability.





CalOffroad



DIFF DROP KITS



CalOffroad diff drop kits are a bolt-in kit that allows the factory front differential to be lowered to reduce CV angles on higher-lifted vehicles.

Once fitted, this kit will lower the differential from 12mm to 36mm, depending on the vehicle make and model. The differential brackets also ensure the vehicle maintains the correct CV geometry. CalOffroad Diff drops are finished in a durable black coating to reduce stone chips and assume a stealth appearance.



BALL JOINTS AND BUSH KITS

CalOffroad offers an integrated solution to enhanced the performance of your 4x4 with our Upper Control Arm Ball Joints and Bush Kits.

Our Upper Control Arm Ball Joints are a perfect fit to CalOffroad Upper Control Arms and a bolt-on replacement for original equipment. Constructed from SCM435 Molybdenum and Chromium Alloy steel, the ball pins undergo heat treatment which improves their wear resistance and extends product life. Employing a Mirror treatment process, the ball stud surfaces are polished to an ultra-smooth finish, facilitating fluid rotation. With options for fixed and adjustable configurations, our ball joints cater to diverse needs.

Complementing our ball joints, the CalOffroad Upper Control Arm Bush Kits ensure peak vehicle stability, braking efficiency, and steering precision. Utilising CalOffroad's advanced composition bushings, these kits offer exceptional elasticity, memory, and unparalleled durability. Compatible with a range of control arms, our bush kits represent a substantial upgrade over stock components, promising superior performance and reliability.

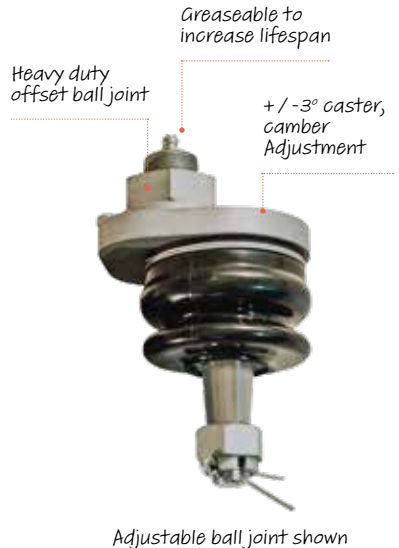

AIR SUSPENSION

BELLOWS LOAD ASSIST KITS

While having a correctly sprung vehicle for constant loads is recommended, leaf springs can exceed daily carrying capacities which could result in a rough, uncomfortable ride when not loaded.

You may also observe a drop in the rear end, leading to adverse effects on safety and handling. To address these issues, installing a set of Polyair Bellows could prove to be an effective solution.

Polyair Bellows load assist kits are meticulously crafted to cater to leaf-sprung vehicles, offering a tailored solution to eliminate any negative loading scenarios.

The bellows kit is air-adjustable, providing the flexibility to customize the level of support based on different load types and weights. The adjustable Polyair Bellows ensure a smooth ride when unloaded and adjustable pressure when towing or hauling, providing a simple yet efficient solution.

Key Features of Polyair Bellows Load Assist Kits:

- **Air Adjustability:** The kits are air adjustable, allowing you to fine-tune the pressure within the range of 5-100psi based on your specific load requirements.
- **Quick Connecting Air Fittings:** Featuring quick-connecting air fittings, the Polyair Bellows load assist kits offer ease of use, ensuring a straightforward and efficient setup.
- **Superior Construction:** Built with a superior 2-ply fabric-reinforced rubber, these kits are designed for durability and reliability, providing robust support for various loading scenarios.
- **Versatile Kit Design:** The kits are thoughtfully designed for both standard height and raised applications, offering versatility to cater to different vehicle setups.
- **Ultra High Strength:** Equipped with ultra-high strength and corrosion-proof Zytel Nylon end caps, the Polyair Bellows demonstrate resilience and longevity in diverse conditions.
- **Drilling Not Required:** For the convenience of installation, most popular kits in the Polyair Bellows lineup do not require drilling into the chassis, simplifying the setup process.
- **Height Options:** The load assist kits are available in both standard height and a 2-inch raised height variant, allowing you to choose the one that best suits your vehicle's specifications.
- **Easy Installation:** The Polyair Bellows load assist kits are designed for easy installation, with illustrated instructions provided to guide you through the process seamlessly.



ON-BOARD AIR COMPRESSOR SYSTEM

Choosing the right air compressor for your needs is a straightforward process considering our range of compressor features designed to complement all Polyair spring kits.

The Polyair compressor system allows you to manage the airbags using an analogue gauge from within the cab area, offering straightforward and user-friendly controls.

Additionally, the wireless alternative takes convenience to the next level. You have the flexibility to control the airbags remotely or via Bluetooth, utilising a free app from either inside or outside the vehicle.

Polyair compressor kits offer a choice between a Single Path System and a Dual Path System. The Single Path System involves routing the airbags together for equal inflation so the two springs inflate simultaneously at the same rate. Alternatively, the Dual Path System allows independent control of the airbags. Each bag has its line, enabling different pressures when dealing with uneven loads.



FIND MY4X4

FORD

Ranger

Everest

HOLDEN

Colorado

Rodeo

ISUZU

Dmax

MU-X

JEEP

Wrangler

MAZDA

BT50

MITSUBISHI

Triton

Challenger

Pajero

NISSAN

Navara

Patrol

Pathfinder

TOYOTA

Hilux

Landcruiser

Prado

FJ Cruiser

VOLKSWAGEN

Amarok





Upgrade your 4X4 Online



On the CalOffroad website, you can find a selection of suspension products to upgrade your off-road experience, delivered directly to your door.



At CalOffroad, we're all about adventure. follow us on social media to stay updated on new products, customer-builds, inspiration, and expert tips.



CALOFFROAD.COM.AU





GalOffroad  