

MYRIAD 'QPC' LITE QUADRAPLEX/TRIPLEX CONTROLLER INSTRUCTION MANUAL



Sigma Controls, Inc.
PROCESS CONTROLS AND INSTRUMENTATION

217 S. Fifth Street, Perkasie, PA 18944
PH: 215-257-3412 FAX: 215-257-3416

VISIT OUR WEBSITE SIGMACONTROLS.COM

MYR QPC LITE MANUAL 040924

TABLE OF CONTENTS

INTRODUCTION.....	3
Ordering Information	
Specifications	
Features	
WIRING.....	7
Dwg # 07-258-1	
Analog Input	
Analog Output	
Digital Input	
Digital Output	
PROGRAMMING AND INITIAL SETUP.....	8
Input Range Selection	
Terminal Block Detail	
Initial Setup & Programming	
Overview/Key Description	
TROUBLESHOOTING & MAINTENANCE.....	21
DIAGNOSTICS.....	22
APPENDIX 'A'.....	24
WARRANTY.....	26
RETURN	27
AUTHORIZATION.....	

INTRODUCTION:

The Sigma Myriad QPC LITE (Quadruplex Pump Controller) is a state of the art microprocessor based, user configurable instrument for the monitoring and control of up to four (4) constant speed or up to four (4) variable speed driven pumps.

The Myriad QPC LITE performs all of the functions found in a full size control panel.

- Displays level in numeric and bargraph forms
- Displays pump call status
- Allows full user selection of all system variables
- Monitors seal leak alarms
- Monitors hand off auto selection switch position
- Provides digital and relay outputs for pump control, level alarm, sensor fail and seal leak
- Permits user selection of pump sequence, alternation and permitted quantity of pumps to run
- Provides 4/20MA outputs for VFD speed setting and proportional control
- Provides time and date 'stamped' alarm information
- Continuous sensor monitor with 'sensor fail' alarm output
- Audible and visual alarms
- Allows simulation of level to exercise pumps or verify operation
- Records "MAX" and "MIN" process values and a graphic trend chart for trouble shooting
- Available in ¼ DIN panel mount or Nema 4X enclosures
- MODBUS® RS485 Data Port

ORDERING INFORMATION:

- | | |
|---------------------------|---------------------------------|
| ▪ 1/4 DIN Case/Back Panel | Sigma Myriad-QPC Lite (-A) |
| ▪ Wall Mount Nema 4X | Sigma Myriad-QPC Lite -N4X (-A) |
| ▪ -A = Option I/O | |

SPECIFICATIONS:

- ANALOG INPUT (1 ea.)
Analog, 4/20MA, 0-5V, 1-5V, 0-10VDC, isolated with common negative, +-0.1% accuracy.
- DIGITAL INPUTS (7 ea.)
Digital 10-30V DC
- ANALOG OUTPUT: (4 ea.)
Analog, with common negative 0-20MA, 4/20MA, 0-5V, 0-10V (voltage output requires a resistor).
- DIGITAL OUTPUTS: (4 ea.)
Opto isolated, solid state, open collector, 100MA 30VDC max.

- RELAY OUTPUTS: (4 ea.)
SPDT, Form 'C' 5A Relay
- Optional I/O Adder, 8 DI/DO
- DISPLAY:
LCD, 128 X 32 pixel bitmapped graphic display
- LOOP POWER:
24VDC regulated output, 100MA max.
- 5 USER KEYS:
Up, Down, Left, Right, Enter
- ACCURACY:
0.1% of calibrated span
- LOCKOUT:
User password, user configurable
- INPUT IMPEDANCE:
Voltage 100K, current 100 OHMS
- POWER:
120VAC (230VAC available)
- ENVIRONMENTAL:
Operating, 0-65° C
Storage, -40° -80° C
R.H., 0-90% non condensing
- ENCLOSURE:
¼ DIN, ABS plastic 96 X 96 X 150MM
- FRONT PANEL:
Gasketed Nema 4X
- ACCESS: (DIN CASE)
Chassis & boards remove from front of case.
- TERMINAL STRIP:
(40) Removable for ease of wiring 28 – 16 AWG

-A Option adds (9) terminals with removable socket
- CONNECTIONS:
Removable screw terminal blocks 28 – 16 AWG wire.

- **CONTROL OUTPUTS:**
4 relay outputs, user programmable, SPDT Form 'C' relays 5 AMP.
4 digital outputs, Opto isolated, open collector.
- **OUTPUT ANNUNCIATION:**
On board piezo buzzer
- CPU Activity Monitor
- **PROGRAMMING:**
Menu based, all parameters and setpoints are user configurable via menu prompts and user keys. The pre-configured screens and 'pull down' sub menus with English prompts assure rapid setup and commissioning.
- 1 YEAR WARRANTY
- **Networking/Data Ports**
Scada compatibility is provided with the rear panel MODBUS® RTU, RS485 Data Port (Slave)
- **EXPANSION CARDS:**
Significant expansion is possible with the –A option which provides 8 factory programmable digital inputs or outputs (as required) along with an 8 megabyte data logger.

FEATURES:

- Microprocessor Based
- Graphic LCD Display
- 5 Function Keys
- Isolated 24VDC Sensor Power
- 4/20MA, 1-5V, 0-5V, 0-10VDC Programmable input
- 1 Analog Input
- 4 Analog Outputs
- 7 Digital Inputs
- 4 Digital Outputs
- 4 Form 'C' Relay Outputs
- Fully User Programmable in English
- 1 Ea. RS485 MODBUS® data port
- CPU Activity Monitor
- 8 DI/DO adder (with –A Option)

WIRING DETAIL

- See Dwg # 07-258-1



CAUTION

All electrical wiring must be in accordance with all local state and national codes that apply.

Do not exceed the rated current of the D.C. power supply (100MA) or the form 'C' relay outputs (5A/240VAC resistive).

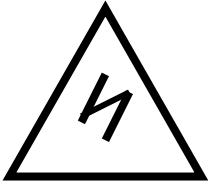

WARNING

Hazardous voltages are present within the enclosure. Installation or service should only be carried out by trained personnel.



CAUTION

The range selector switches located on the bottom of the circuit board are factory set. If a field change of input type is required see Appendix 'A'. Do not apply an input signal that is not coordinated with range switches or the unit may be damaged.

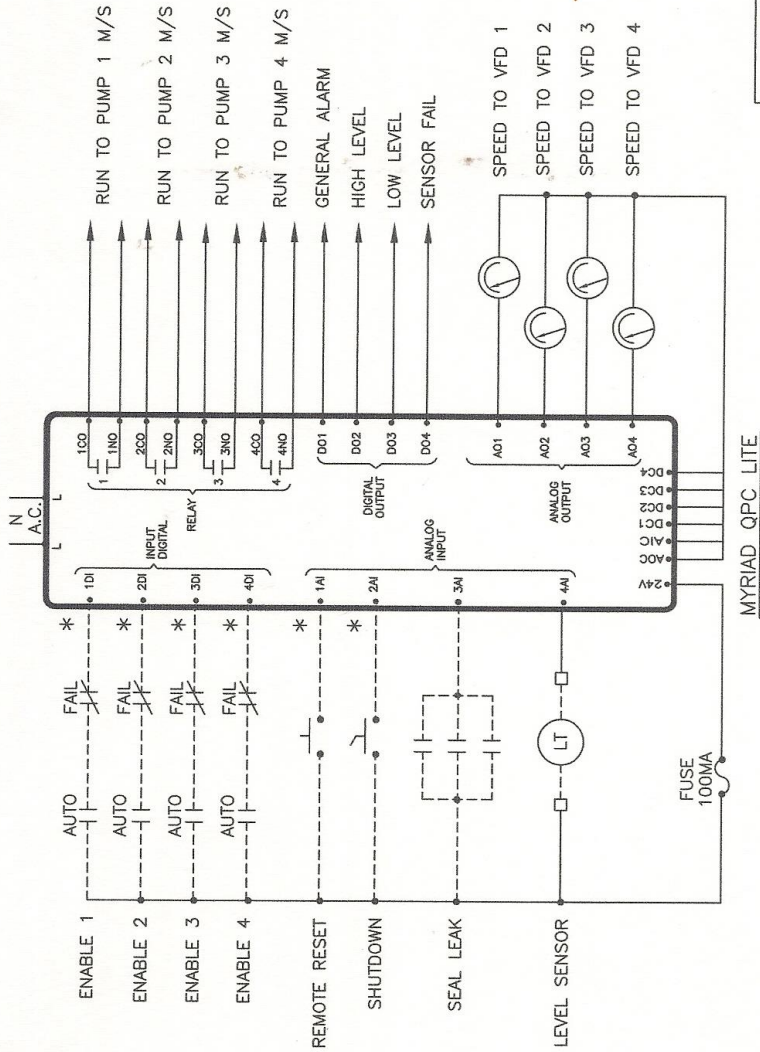

- * NOTES
- 1.) ENSURE INPUT JUMPERS ON MAIN BOARD ARE CORRECTLY CONFIGURED.
 - 2.) JUMPER IF NOT USED

SIGMA CONTROLS, INC.	217 South 5th Street, Perkasie, Pa. 18944 Phone: (215) 267-3412 Fax: (215) 267-3416		
	MYRIAD 'QPC LITE' QUADRAPLEX CONTROLLER I/O DETAIL		
Client:	SIGMA CONTROLS		
Dwg. No.:	07-258	Date:	10-5-07
Sheet	1 of 1	Scale:	N.T.S.
P.O. #			JOB #

PROGRAMMING & SETUP

The Myriad QPC utilizes 'plain English' menu driven setup screens which are intuitive and easily understood.

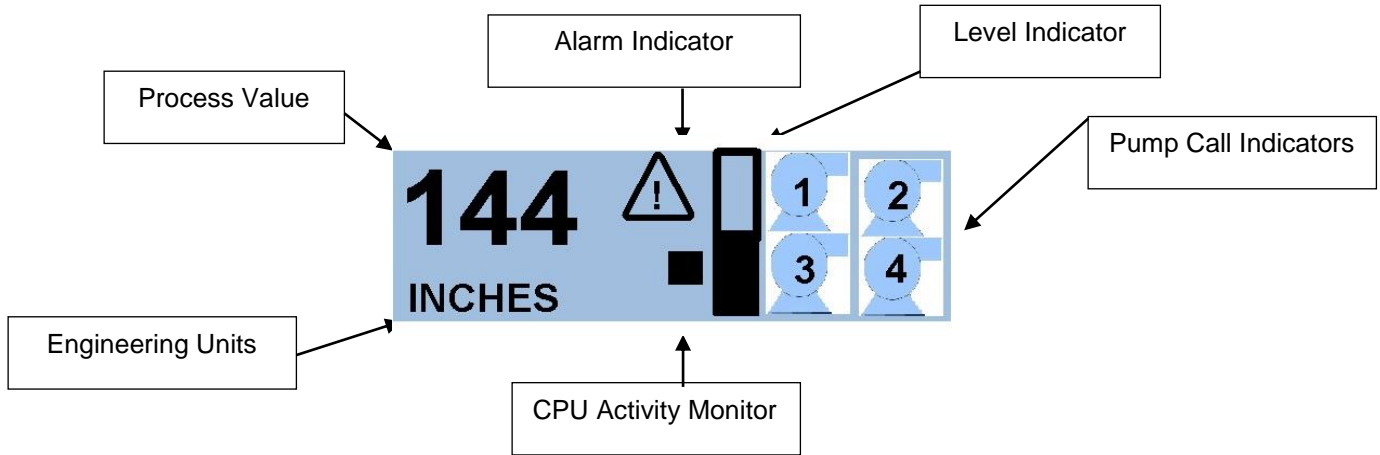

MAIN DISPLAY

NOTE: To 'RETURN' to the main display from any other screen, scroll to 'EXIT' and press 'ENTER'.

From the default screen (Fig. 1), push the 'Enter' button to enter the password protected menus.

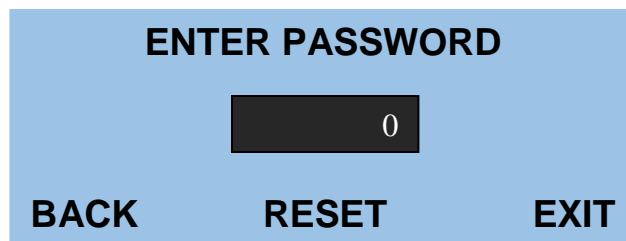

Enter the user selected password (factory default is zero) using the ↑ ↓ keys and press 'Enter' to access the first programming menu 'Menu 1'.

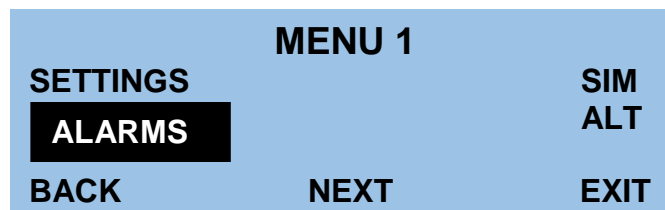

NOTE: Programming should begin at 'Menu 2'. 'SCALE' to set the instrument for the correct input signal from 'Menu 1'. Use the → ← buttons to highlight the 'NEXT' item and press enter to access 'Menu 2'.

MENU 2 SCALE

AOUT	MENU 2	SETUP
SCALE		DIAGS
VIEW	NEXT	EXIT

Use the → ← buttons to highlight 'SCALE' and press 'ENTER'.

INPUT TYPE		
4/20MA		
# OF POINTS 2		
BACK	NEXT	EXIT

This first screen shows what type of analog input is being used. **NOTE: INPUT TYPE MUST BE COORDINATED WITH INPUT SELECTOR SWITCH LOCATED ON THE BOTTOM OF THE CIRCUIT BOARD** (See Appendix 'A')

The 'QPC' does not include linearization of the input signal. The display is linear over the 2 points selected.

DECIMAL POINT SELECTOR SCREEN

DECIMAL POINT		
ex.	+++.	
	3.0	
BACK	NEXT	EXIT

The cursor will be positioned over the decimal count window. Use the Up/Down ↑ ↓ arrow buttons to raise or lower the unit number to the left of the decimal point. (The example shown in this window will change with your selection.)

Use the → ← buttons to move the cursor to the number behind the decimal point and the Up/Down ↑ ↓ buttons to change this selection. Once again, the example will change to confirm your selection.

Use the → ← buttons to highlight the 'NEXT' selection and press 'ENTER' to access the Input Scale Screen.

INPUT SCALING TO ENGINEERING UNITS

INPUT SCALE		
4.00 MA	=	0
20.00 MA	=	144
BACK	NEXT	EXIT

NOTE: This screen sets what the Myriad QPC displays in the main display for the selected input.

The example shown above will display 0.0 units when the input is 4.00 MA. Both the input and the display at that input can be changed for different requirements.

A) With the cursor selecting 'INPUT = 4.00' (or the zero value of the selected input) use the ↑ ↓ buttons to change the input value for the required displayed value.

B) Use the → ← buttons to move the cursor to the 'display' value and the Up/Down buttons to change the desired display for the previously selected input. Once complete, scroll to 'SAVE', press 'ENTER' to access 'INPUT SCALE 2' screen.

ENGINEERING UNITS SELECTION:

When 'Scale Menu' is complete the 'INPUT TEXT' menu is the last menu in the scaling process.

INPUT TEXT		
FEET OF WATER		
BACK	NEXT	EXIT

This screen allows the selection of several engineering units. With the cursor on the default value as shown, press the Up/Down buttons to select between

FEET	NTU
INCHES	PPM
GPM	DEG. F
PSI	DEG C
LPM	FLOATS
ING HG	TONS/HR
MGD	PH

Use the ↑ ↓ keys to select the desired engineering units then with the → ← keys, highlight 'NEXT' and press 'ENTER' to access the "display filter" screen.

DISPLAY FILTER SCREEN



Use the ↑ ↓ keys to change the amount of filtering applied to the input signal. '0' is no filter and '10' is high filter.



Too much filtering will dampen process responses.

Scroll to 'NEXT' and press 'ENTER' to return to the Menu 2.

ANALOG OUTPUT (AOUT)

Use the → ← keys to highlight the 'AOUT' item and press 'ENTER' to access the analog output signal settings.

NOTE: There are four analog outputs on the QPC. All 4 Analog Outputs are speed vs. level setpoints which are only utilized on variable speed drive applications. This screen allows the user to program the speed of the drive at a selected level. Both level and drive speed are selectable.

LEAD SPEED SCALE

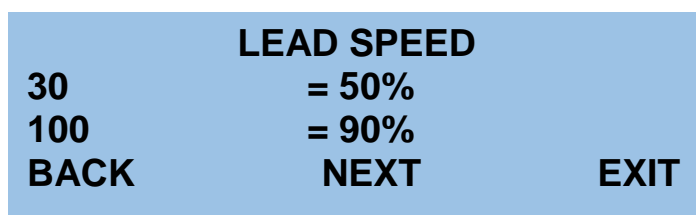

The 'level' value will be highlighted, use the ↑ ↓ keys to change the level point at which the speed of the drive (selected in the next block) is requested. In the example above, the drive will be at 50% speed when the level is 30 inches and only the lead pump is called to run.

Scroll to 'NEXT' and press 'ENTER' for LAG speed.

LAG SPEED SCALE

LAG SPEED		
40	= 60%	
101	= 91%	
BACK	NEXT	EXIT

Select a value of drive speed and level as described above and scroll to 'EXIT' to save the values selected and move to the Main screen.

As described above, select an output value versus display value for analog output 4. When complete use → ← to select 'NEXT' and press 'ENTER'.

LAG 2 SPEED SCALE

LAG 2 SPEED		
40	= 55%	
110	= 92%	
BACK	NEXT	EXIT

The 'level' value will be highlighted, use the ↑ ↓ keys to change the level point at which the speed of the drive (selected in the next block) is requested. In the example above, the drive will be at 55% speed when the level is 40 inches and the lead, lag and lag 2 pumps are called to run.

Scroll to 'NEXT' and press 'ENTER' for LAF3 speed.

LAG 3 SPEED SCALE

LAG 3 SPEED		
60	= 70%	
110	= 95%	
BACK	NEXT	EXIT

Select a value of drive speed and level as described above and scroll to 'EXIT' to save the values selected and move to the Main screen.

As described above, select an output value versus display value for analog output 4. When complete use → ← to select 'SAVE' and press 'ENTER'.

From menu 2 use the → ← keys to select 'SETUP' and press enter to access the setup menu.

SETUP

NOTE: The 'SETUP' menu allows access to the following items:

- 1) Trend screen time base
- 2) Password
- 3) Time
- 4) Month
- 5) Date
- 6) Day
- 7) Alarm Horn on/off

TREND SPEED SCREEN



NOTE: The trend screen is provided as a diagnostic tool. This trend graphic will display the process value over the time duration selected. The duration of the trend is selectable between 2 minutes, 2 hours, 12 hours and full speed. The trend is non-retentive and will overwrite previous data.

Use the ↑ ↓ keys to select the desired time base and scroll to 'NEXT' and press 'ENTER' to move to the 'Change Password' screen.

'CHANGE PASSWORD SCREEN'

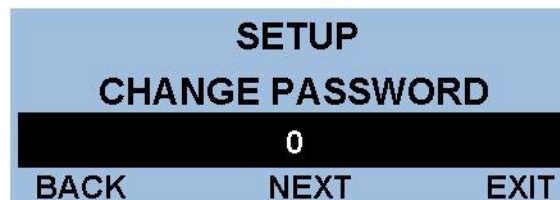

Once the password has been changed make sure a record of the new password is retained. Access to the programming menus requires a correct password.

Use the ↑ ↓ keys to enter a number up to 9999, select 'NEXT' and press 'ENTER' to enter the 'change clock' menu.

CHANGE CLOCK, MONTH, DATE AND DAY SCREENS

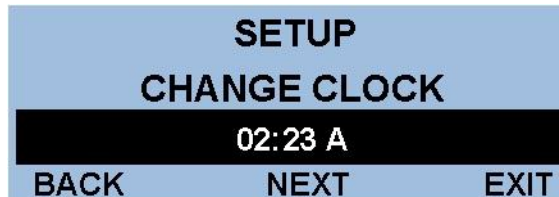

As described previously, use the ↑ ↓ keys to set the screen to the current time. Scroll to 'NEXT' and press 'ENTER' to move to the change month screen.

The 'change month' screen, 'change date' screen, and 'change day' screen are all adjusted as above. After changing the 'DAY' screen, scroll to 'NEXT' and press 'ENTER' to select the 'Alarm Horn' screen.

NOTE: DAYLIGHT SAVINGS CHANGES ARE NOT AUTOMATIC.

ALARM HORN SCREEN



NOTE: Selecting the alarm horn to 'OFF' will disable the internal piezo alarm from sounding when an alarm condition occurs.

When the desired selection is made, scroll to 'NEXT' and press 'ENTER' to return to MENU 2. In Menu 2 select 'NEXT' and 'ENTER' to select Menu 1.

MENU 1



From Menu 1 select 'Settings' and press 'ENTER' to access the 'LEAD PUMP ON' setpoint.

LEAD PUMP ON

SETTINGS		
LEAD ON AT		
80		LEV
BACK	NEXT	EXIT

NOTE: This parameter determines at what level the 'lead' pump turns on. Using the ↑ ↓ keys select a level point to turn on the lead pump. Scroll to 'NEXT' and press 'ENTER' to access the:

LEAD PUMP OFF SCREEN

SETTINGS		
LEAD OFF AT		
30		LEV
BACK	NEXT	EXIT

Following the procedure above, select a level value at which the lead pump turns off. Use 'NEXT' with the exit button to access the:

LAG PUMP ON SCREEN

SETTINGS		
LAG ON AT		
100		LEV
BACK	NEXT	EXIT

Select a value, turning on the lag pump. Use 'NEXT' and 'EXIT' to access the:

LAG PUMP OFF SCREEN

SETTINGS		
LAG OFF AT		
40		LEV
BACK	NEXT	EXIT

Again, select a level value, which turns off the lag pump. Select 'NEXT' and press 'EXIT' to advance to the Lag 2 and Lag 3 settings.

PUMP ON DELAY SCREEN

SETTINGS		
PUMP ON DELAY		
1		SEC
BACK	NEXT	EXIT

This screen allows an operator selected delay before a pump is operated after its 'ON' setpoint has been reached. Sometimes this delay is required to overcome process disturbances such as pressure or wave action.

Change the 'ON' delay as required and select 'NEXT' and press 'ENTER' to advance to the:

PUMP OFF DELAY SCREEN

SETTINGS		
PUMP OFF DELAY		
1		SEC
BACK	NEXT	EXIT

Change pump off delay as described above and select 'NEXT' and press 'ENTER' to advance to the:

LEVEL ALARM SCREENS

The next screens are as follows:

- Low Level Alarm Set Point
- Low Level Alarm Reset Point
- High Level Alarm Set Point
- High Level Alarm Reset Point
- Alarm Timer

Adjust and advance through the alarm settings as described previously. The 'alarm timer' provides an adjustable time delay for alarm notification after the alarm setpoint has been reached in order to prevent nuisance alarms.

After the 'alarm timer' has been set return to Menu 1 and select 'ALT', press 'ENTER' to access the alternative menu.

'ALTERNATION'

From Menu 1 select 'ALT' and press ENTER to select the Lead/Lag order screen.

LEAD/LAG ORDER SCREEN

```
LEAD / LAG ORDER
LEAD  1          LAG 1  2
2 LAG  3          3 LAG  4
BACK          NEXT          HELP
```

The example shows the #1 pump as the 'Lead', #2 as the 'Lag', #3 pump as the second 'Lag', and #4 pump as the third 'Lag'. The starting position of any pump may be changed in this screen by positioning the cursor with the → ← buttons and selecting the desired pump sequence. **NOTE:** If alternation is enabled, the pump sequence will change based on time or pump cycle. If alternation is selected to be 'off' then pump sequence will be 'fixed' per the selected 'pump order'.

```
SELECT PUMPS IN
ORDER, PUT UNUSED
LAST, ONE OF EACH
(IE: 1, 3, 2, 4)
```

The help screen can be selected from the Lead/Lag Order screen or it may appear if an incorrect pump order was entered. This screen explains that pump numbers should be entered in the order in which they come on. If there are unused pumps, enter them as coming on last. You must enter each pump once.

ROTATE PUMPS SCREEN

```
PUMPS TO ALT
ROTATE 3 PUMPS
<IE: 2 = DUPLEX>
BACK          NEXT          EXIT
```

This screen is provided to allow the operator to limit the maximum number of pumps to be alternated. In the example shown the cursor is over the programmable number of pumps allowed to be in the alternation cycle, i.e. 3 pumps (Triplex).

If this were a 4 pump system, all 4 pumps would be allowed to run but only 3 pumps would be allowed to rotate lead/lag position.

Use the ↑ ↓ keys to select a time of day to alternate. Select 'NEXT' and press 'ENTER' to return to Menu 1.

MAXIMUM PUMPS ALLOWED SCREEN



This screen allows the operator to select the maximum number of pumps that are allowed to run regardless of level conditions. Select the maximum number of pumps with the ↑ ↓ buttons.

ALTERNATION SCREEN



NOTE: Three options are available for alternating the pump lead position:

- A) 'ALT OFF' no alternation of lead/lag pump.
- B) 'WHEN PUMPS STOP' pumps alternate when a pump has completed a pump cycle.
- C) 'DAILY' allows for alternation of the pumps in systems, which run continuously. Selecting 'DAILY' brings up a new selection, which is the time of day at which the pumps will alternate their position in the sequence even if they are operating.

From 'Menu 1' select 'ALARMS' and press 'ENTER' to view the current alarm status.

ALARMS



NOTE: In this menu item, all alarm screens will be shown in an automatically 'SCROLLING' fashion. The following alarm status will appear on the screen:

- Seal Leak Alarm
- High Level Alarm
- Low Level Alarm
- Sensor Failure
- System Shutdown

Any alarm that is currently active will be indicated on its screen by the lower display changing from 'NOT ACTIVE' to 'ACTIVE'. Any 'ACTIVE' alarm must be reset by selecting 'RESET' with the → ← arrows and pressing 'ENTER' **after the causal condition has been removed.**

NOTE: While in the main display any alarm condition which occurs during normal operation will cause a time and date 'stamped' message to pop-up over the main display screen indicating the specific alarm condition. The on board horn will sound. To clear the screen and stop the horn, press any key.



On the main display a  will flash indicating that an alarm condition still exists. This indicator will be removed after the alarm has been cleared as described above. The 'RESET' selection appears on the 'ALARMS' and the 'ENTER PASSWORD' screens.

OPERATIONAL INFORMATION

Several items of operational information are provided for operator review of system status. These items may be accessed from the 'VIEW' screen, which appears at the bottom of the 'PASSWORD' entry screen.



From the main menu press 'ENTER' key to access the 'ENTER PASSWORD' screen. Use the → ← keys to scroll to the 'VIEW' position and press 'ENTER'.

NOTE: IT IS NOT NECESSARY TO ENTER A PASSWORD TO ENTER THIS SCREEN.

VIEW MENU

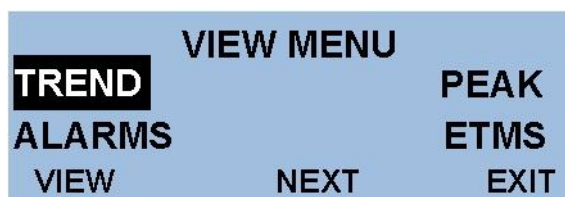

'TREND' will be highlighted. Press 'ENTER' to view the recorded trend of the process value for the time selected previously during the setup procedure (2 min., 2 hrs, 12 hrs, or full speed).



After viewing the process trend press 'ENTER' to return to the 'VIEW' menu. Select 'PEAK' with the → ← keys and press 'ENTER'.

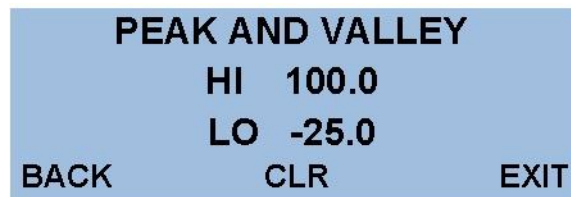

This screen records the highest and lowest process values that have occurred since the last 'CLR' (clear). To reset these values to the current value of the process, scroll to 'CLR' and press 'ENTER'. The cursor will automatically move to the 'BACK' position, press 'ENTER' to return to the 'VIEW' menu. Select 'ALARMS' and press enter to view the current alarm status and use 'RESET' as described previously to clear any active alarms. Select 'BACK' and press 'ENTER' to return to the 'VIEW' menu.

MAINTENANCE AND TROUBLE SHOOTING

MAINTENANCE:

The Myriad QPC LITE is a digital solid-state device, which requires no periodic maintenance.

Occasional physical checks of the unit should be carried out for physical and mechanical security of mounting, terminal blocks, and electrical wiring.

TROUBLE SHOOTING:

- UNIT 'LOCKS UP' – Recycle power to the unit by removing AC power, waiting 10 seconds and reconnecting power.



NOTE: This should be done by using the user provided circuit breaker or fuse, not by removing the power wires at the terminal block. **Serious injury or death can occur if contact is made with the incoming ac power.**

WARNING

- LCD display goes dim or contrast is poor. Remove power from the unit, release the 2 rear mounting screws and slide the unit forward in its case approximately 1 inch. On the left side of the circuit board is an adjustable potentiometer. With a small screwdriver adjust this “pot” to alter the contrast to the desired amount. Return the unit to its normal position and secure the rear screws.
- DISPLAY REMAINS AT ZERO OR SHOWS NO CHANGE -- If the display remains at zero or shows no change but the process is changing, check for D.C. voltage on the loop. With 2 wire (4/20MA) instruments check with a D.C. voltmeter at the level instrument by disconnecting the level instrument from its 2 wires and measuring across these 2 wires with a D.C. voltmeter for the presence of 24VDC.

If D.C. voltage is present, reconnect the negative wire of the supply and insert a milliamp meter between the positive wires. The loop should provide a signal between 4 and 20 MA. If no current is present or Y current exceeds 20MA consult the level instrument supplier.

If D.C. voltage is not present check the user supplied power supply or if using the Myriad supply measure across terminals 24VDC and A/C. If no 24VDC is present consult factory. If 24VDC is present check field wiring between the Myriad and the field device and recheck ‘SCALE’ functions to insure correct setup.

- Unit appears to be functioning but does not bring on pumps or alarms. From ‘MENU 2’ scroll to ‘DIAG’ and press enter:

DIAGNOSTIC SCREENS

INPUTS

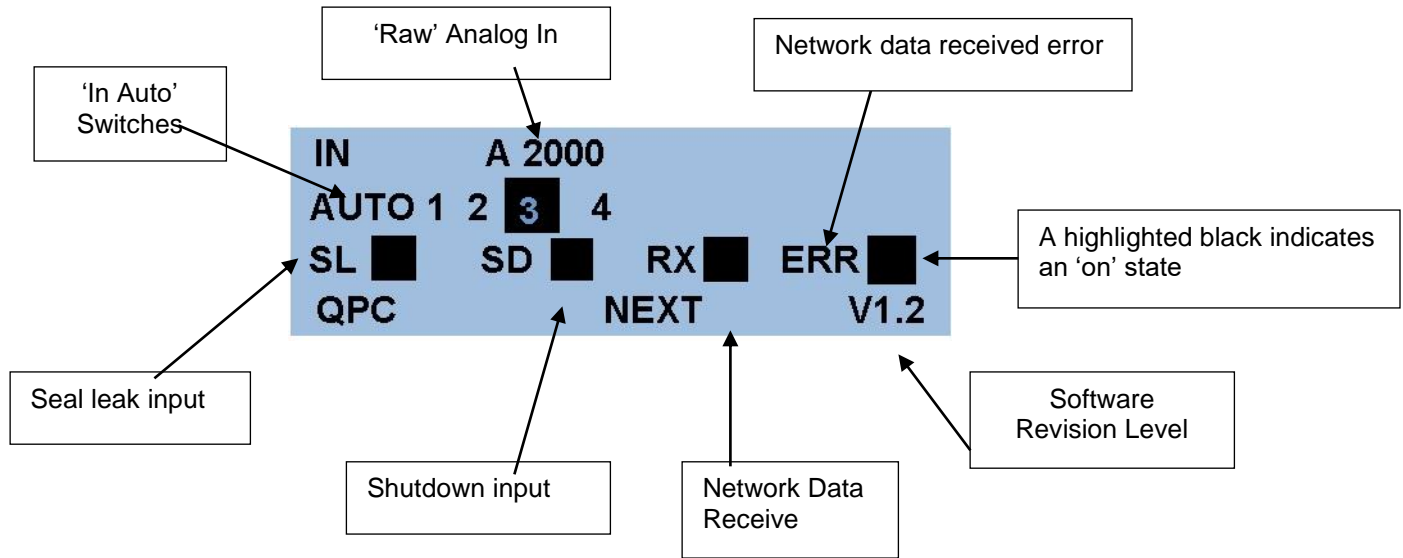

Select 'NEXT' and press 'ENTER' to view the output screen.

OUTPUTS

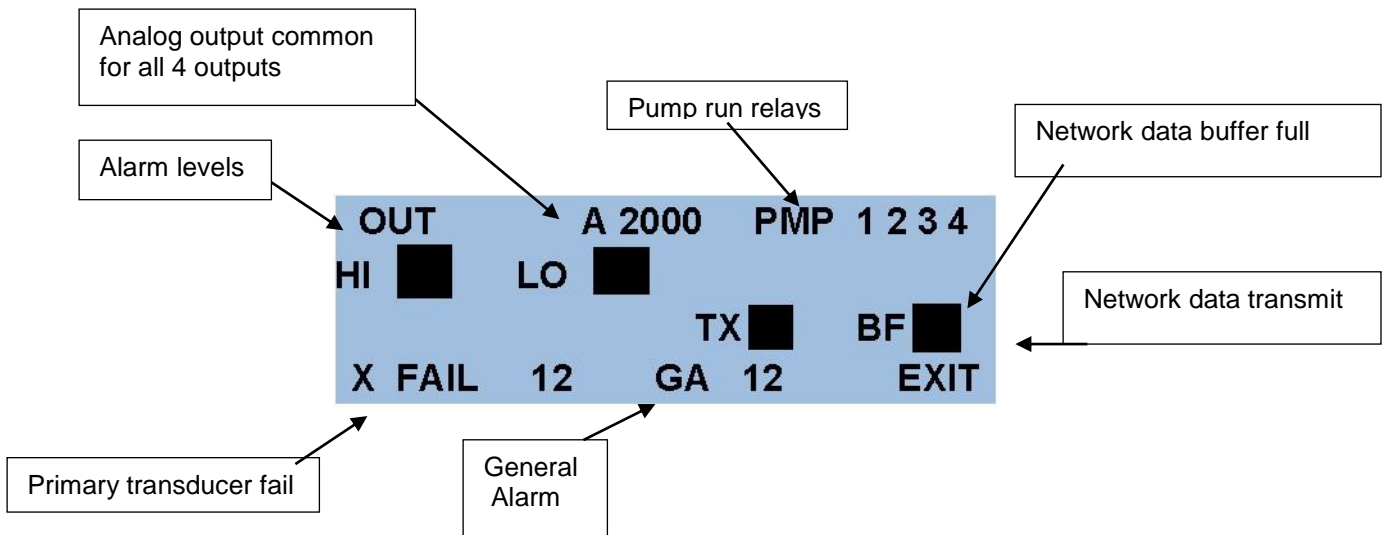

The diagnostic screens provide information about the current status of inputs and outputs and provide valuable information to aid in trouble shooting.

The screens show the status of the 'RAW' analog input and output values. These raw values are approximately the input and output range in the selected input value; as shown, the input is 20.00 MA and the output is 20.00 MA. These values can provide help in determining if the Myriad QPC is receiving the correct analog input.

NOTES ON ALARMS

(1) Seal leak, all seal leak inputs are connected to a single digital input 3AI. When either of these are closed the non-critical alarm is activated. The pumps are not shut down.

(4) H.O.A. selectors, are monitored for their position at DI1 -DI4. If an HOA is not in the 'Auto' position that pump will not be permitted to run.

(5) The system shutdown alarm will 'kill' the pumps when activated.

APPENDIX 'A'

SWITCH SELECTION OF ANALOG INPUT RANGES (Factory default 4/20MA).

The range dip switches are located on the bottom of the main circuit board. Disconnect power, remove two rear screws, remove terminal strips, and slide the entire unit out of its case. Turn the unit upside down to locate the range dip switches.

SW1	SW2	INPUT 1	DESCRIPTION
0	0		Ain1 range = 5V
0	1		Ain1 range = 10V
1	0		Ain1 range = 20Ma
1	1		Not Used

SW3	SW4	DESCRIPTION
0	0	AIn2 range = 5V
0	1	AIn2 range = 10V
1	0	AIn2 range = 20mA
1	1	Not Used

SW5	SW6	DESCRIPTION
0	0	AIn3 range = 5V
0	1	AIn3 range = 10V
1	0	AIn3 range = 20mA
1	1	Not Used

SW7	SW8	DESCRIPTION
0	0	Ain4 range = 5V
0	1	Ain4 range = 10V
1	0	Ain4 range = 20mA
1	1	Not Used

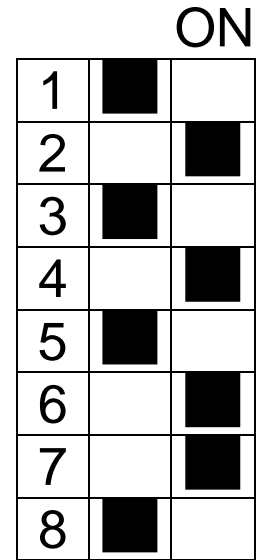

EXAMPLE ONLY

(TYPICAL FOR DPC, TPC, QPC)



CAUTION, ENSURE THAT DIP SWITCHES ARE CORRECTLY SET FOR INPUT RANGE REQUIRED.

SIGMA MYRIAD QPC LITE PROGRAMMING RECORD SHEET

Model Number: _____

Serial Number: _____

Vers: _____

Password: _____

- **Scale:**

Input Type _____

Input Points _____

Decimal Point _____

- **Input Scale 1:**

Input = _____

Display = _____

- **Input Scale 2:**

Input = _____

Display = _____

Engineering Units _____

Display Filter # _____

- **Settings**

Lead on at _____

Lead off at _____

Lag on at _____

Lag off at _____

2nd lag on at _____

2nd lag off at _____

3rd lag on at _____

3rd lag off at _____

Pump on delay _____

_____ Pump off delay _____

Low level alarm set _____

Low level alarm reset _____

High level alarm set _____

High level alarm reset _____

Alarm timer _____

- **Analog Output (AOUT)**

Lead Scale 1:

Level = _____

Speed = _____

Lead Scale 2:

Level = _____

Speed = _____

Lag Scale 1:

Level = _____

Speed = _____

Lag Scale 2:

Level = _____

Speed = _____

- **Alternation:**

Lead Lag Order

Lead _____ Lag _____

2nd Lag _____ 3rd Lag _____

Pumps to Alt _____

Max # Pumps Allowed _____

Alternation _____

Sigma Controls, Inc.

PROCESS CONTROLS AND INSTRUMENTATION



217 S. Fifth Street, Perkasie, PA 18944
PH: 215-257-3412 FAX: 215-257-3416

WARRANTY

All Sigma Controls, Inc. products are warranted to be free from defective materials and workmanship for one (1) year from date of shipment. Sigma reserves the right to repair or replace at its option any product found to be defective. In no event shall Sigma Controls, Inc. be liable for any consequential, incidental, or special damages and the limit of its liability shall not exceed the purchase price of the supplied equipment.

RETURN FOR REPAIR POLICY (WARRANTY/NON-WARRANTY REPAIR)

Return status can be determined upon factory inspection of returned equipment.

A completed Return Authorization form must accompany all items returned for repair.

Repairs will be evaluated as quickly as possible. Cost for non-warranty repairs will be provided before repairs are initiated and repairs will be completed only after approval by customer.

217 S. 5TH Street, Perkasie, PA 18944 215-257-3412

MYRIAD RETURN AUTHORIZATION FORM

User Company Name & Address:	Name & Phone # to contact for information:

Reason for Return:	Possible Cause of Problem:

Model #:	Serial #:
----------	-----------

Application:

Urgency of Repair:
Calibration desired for meter:
PO # for Non-Warranty Repairs:
M.S.D.S. if applicable:

NOTE: PLEASE PACK IN ANTI STATIC PROTECTION SUITABLE FOR SENSITIVE ELECTRONIC DEVICES.

