

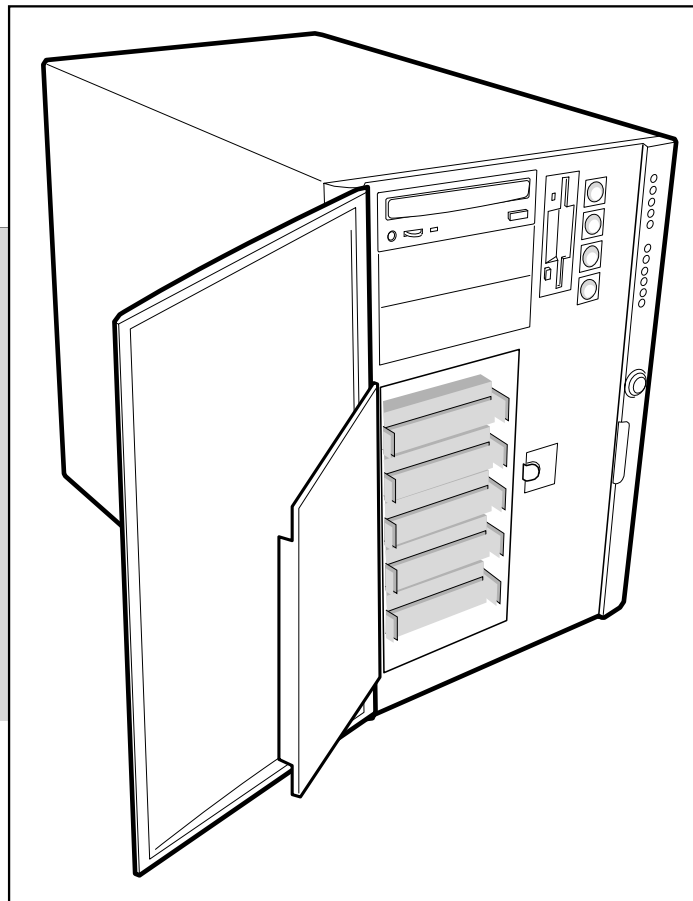

FT SERIES

FT5000 Handbook



Certificate No.'s:
FM 1716 FS 21715 FS 30305

APRICOT FT SERIES

With up to four Pentium®/Xeon™ processors

FT5000 HANDBOOK

Intel and "Pentium®II Xeon" are registered trademarks of Intel Corporation.

Microsoft, MS-DOS, Windows®95, Windows®98 and Windows®NT are registered trademarks of Microsoft Corporation in the US and other countries.

Other trademarks mentioned within this document and not listed above are the properties of their respective owners.

Information contained in this document is subject to change without notice and does not represent a commitment on the part of Apricot Computers Limited. Any software described in this manual is furnished under a license agreement. The software may be used or copied only in accordance with the terms of this agreement. It is against the law to copy any disk supplied for any purpose other than the purchaser's personal use.

No part of this manual may be reproduced or transmitted in any form or by any means electronic or mechanical including photocopying and recording, for any purpose, without the express written permission of the publishers.

Copyright © Apricot Computers Limited 1998. All rights reserved.

Published by:
Apricot Computers Limited
3500 Parkside
Birmingham Business Park
Birmingham, England
B37 7YS

<http://www.mitsubishi-computers.com>



Printed in the United Kingdom

CONTENTS

Safety and Regulatory notices

General	i
Maintenance and Transporting	ii
Standards and Legalities	iii
Power connection	iii

1 Introduction

Physical specifications	1/1
Feature summary	1/2
Environmental specification	1/2
Front controls and indicators	1/3
Back controls and features	1/4
Expanded side view	1/5
Peripherals	1/6
Power supply	1/6
System security	1/7

2 Working inside your system

Tools and supplies needed	2/1
Before you remove any cover	2/1
Warnings and cautions	2/1
Access cover	2/2
Subchassis and electronics bay	2/3
Add-in boards	2/4
Installing a peripheral in a front bay	2/5
Fans	2/7

3 Exchanging SCSI drives

SCSI hard disk drives	3/1
Hot-swapping a SCSI hard drive	3/2
Drive cabling considerations	3/4
Drive cabling considerations	3/9

4	Power supplies	
	Tools and supplies needed	4/1
	Before you remove any cover	4/1
	Warnings and cautions	4/1
	General specification	4/2
	Power supply indicators	4/2
	Replacing a power supply	4/3
5	Mainboard	
	Mainboard features	5/1
	Connector and component locations	5/2
	Jumpers	5/3
	Before carrying out any work in the system	5/4
	General procedure for all jumper settings	5/5
	Processors	5/6
	Voltage regulator modules	5/10
	Memory	5/11
	Removing the memory module	5/12
	Removing and installing DIMMs	5/14
	Replacing the backup battery	5/16
	Add-in board slots	5/17
	SCSI and IDE controllers	5/18
6	I/O addresses, interrupts etc.	
	System I/O addresses	6/1
	Memory map	6/3
	Interrupts	6/3
7	Configuration software and utilities	
	Utilities and hot keys	7/1
	Power On Self Test (POST)	7/2
	Using BIOS Setup	7/2
	Setup menus	7/4
	Using the system setup utility	7/13
	Emergency management port console	7/22
	FRU and SDR load utility	7/32
	Upgrading the BIOS	7/35
	Using the firmware update utility	7/38

Installing video drivers	7/38
Using the SCSI utility	7/38

8 Problem solving

Initial system startup	8/1
After the system has been running correctly	8/2
Specific problems and corrective actions problems	8/4
Error and informational messages	8/7
POST error codes and messages	8/10

Appendix Rack mounting the FT5000

Safety guidelines	A/1
Additional precautions for rack mounting	A/2
Changing from pedestal to rack	A/3
Prepare the slide assemblies	A/4
Prepare the server	A/5
Prepare the equipment rack	A/7
Install the server in the rack	A/9

Equipment log and configuration record

Two pages to note down important system information and configuration details.

SAFETY AND REGULATORY NOTICES

General

Avoid personal injury

To avoid personal injury when unpacking the server, use a mechanical assist unit to lift it off the shipping pallet. The minimum server configuration weighs 38 kg; the maximum weighs 45 kg.

- ◆ Do not attempt to lift or move the server by the handles on the power supplies.
- ◆ Use a hand-truck or other mechanical assist unit to move the server from one location to another, or to raise it into position for rack mounting.

Electrical

The computer uses a safety ground and must be earthed.

The system unit AC power cord is its 'disconnect device'. Ensure that the system unit is positioned close to the AC power outlet and that the plug is easily accessible.

The power cord packed with the computer complies with the safety standards applicable in the country in which it is first sold. Use only this power cord. Do not substitute a power cord from any other equipment.

To prevent fire and electric shock, do not expose any part of the computer to rain or moisture. Turn off the computer and unplug all power cords before moving or cleaning the system unit, or removing the system unit top cover.

Battery

This product contains a lithium battery.

Do not use a metal or other conductive implement to remove the battery. If a short-circuit is made between its positive and negative terminals the battery may explode.

Replace a discharged battery with one of the same type; another type may explode or ignite. Follow any instructions contained in this handbook to replace the battery. Dispose of a discharged battery promptly and in accordance with the battery manufacturer's recommended instructions. Do not recharge, disassemble or incinerate the discharged battery. Keep away from children.

Laser products

Any CD-ROM drive fitted in this system is classified as a CLASS 1 LASER PRODUCT according to IEC825 *Radiation Safety of Laser Products (Equipment Classification: Requirements and User's Guide)*. The CLASS 1 LASER PRODUCT label is located on the underside of the system unit.

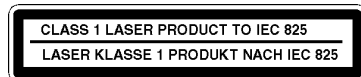

The CD-ROM drive contains a laser system which is harmful to the eyes if exposed. Do not attempt to disassemble the CD-ROM drive; if a fault occurs, call an authorised maintainer.

Use the CD-ROM drive only as described in this manual. Failure to do so may result in exposure to hazardous radiation.

Anti-static precautions

WARNING

Static electricity can cause permanent damage to electronic components. You should be aware of this risk, and take precautions against the discharge of static electricity into the computer.

The computer is at risk from static discharge while the top cover is off. This is because the electronic components of the motherboard are exposed. Memory modules, expansion cards and replacement processors are examples of electrostatic sensitive devices (ESSDs).

All work that involves removing the cover must be done in an area completely free of static electricity. We recommend using a Special Handling Area (SHA) as defined by EN 100015-1: 1992. This means that working surfaces, floor coverings and chairs must be connected to a common earth reference point, and you should wear an earthed wrist strap and anti-static clothing. It is also a good idea to use an ionizer or humidifier to remove static from the air.

When installing any upgrade, be sure you understand what the installation procedure involves before you start. This will enable you to plan your work, and so minimise the amount of time that sensitive components are exposed.

Do not remove the system unit cover, nor the anti-static bag or wrapping of any upgrade, until you need to.

Handle static-sensitive items with extreme care. Hold expansion cards and add-on components only by their edges, avoiding their electrical contacts. Never touch the components or electrical contacts on the motherboard or on expansion cards. In general, do not handle static-sensitive items unnecessarily.

Keep all conductive material, and food and drink, away from your work area and the open computer.

SAFETY & REGULATORY NOTICES

Thermalcote bonding compound

The thermal bonding compound used between the system processor and its heat sink can cause skin irritation and stain clothing. Avoid prolonged or repeated contact with skin. Wash thoroughly with soap and water after handling. Avoid contact with eyes and inhalation of fumes. Do not ingest.

Ergonomic

When positioning the system unit, monitor and keyboard, take into account any local or national regulations relating to ergonomic requirements.

Maintenance

Switch off and disconnect all cables before attempting to clean the computer.

Do not use sprays, solvents or abrasives that might damage the system unit surface. Do not use cleaning fluids or sprays near air vents, ports, or the diskette and CD-ROM drives.

Occasionally wipe the system unit with a soft, slightly damp, lint-free cloth.

Occasionally wipe over the air vents on the rear and sides of the system unit. Dust and fluff can block the vents and limit the airflow.

Occasionally clean the diskette and CD-ROM drives using a proprietary head cleaner.

Occasionally wipe the monitor with a soft, slightly damp, lint-free cloth.

It is best to use anti-static glass cleaner on the monitor screen, but do not spray glass cleaner directly onto the screen; it could run down inside the case and damage the circuitry.

Transporting

Use common sense when handling the computer; hard disks in particular can be damaged if the computer is dropped or handled roughly. As a precaution, back up the contents of the hard disks to tape or diskettes before moving the computer.

Switch off and disconnect all cables before attempting to move the computer, particularly do not try to move the computer while it is plugged into the AC power supply.

When lifting and carrying the computer, use the metal sides of the system unit and never attempt to lift the system unit with a monitor still on top.

If you need to transport the computer any great distance, use the original packing materials.

If you are planning to use the computer in another country, it may not be suitable, check with your supplier, particularly on the availability of the correct AC power cords.

NOTE

Any existing maintenance or warranty agreement may not be supportable in another country. The system may have to be returned to the supplier.

Legalities

This equipment complies with the relevant clauses of the following European Directives (and all subsequent amendments):

Low Voltage Directive	73/23/EEC
EMC Directive	89/336/EEC
Telecommunications Directive	91/263/EEC
CE Marking Directive	93/68/EEC

IMPORTANT

This system, when supplied, complies with the CE Marking Directive and its strict legal requirements. Use only parts tested and approved by Mitsubishi Electric PC Division. All expansion cards, drives and peripherals should carry the CE mark.

Standards

Safety

This product complies with the European safety standard EN60950 which will, when applicable, include the national deviations for the country in which it is sold.

Electro-magnetic Compatibility (EMC)

This product complies with the following European EMC standards:

Emissions EN50022 Class A

Immunity EN50082-1

This product also complies with the following International EMC standards:

VCCI Class A (Japan)

Notes

All interconnecting cables (for example, signal and communication cables) should be less than 2 metres in length. If cable extensions are used, ensure adequate earth connections are provided and screened cables are used.

If any metal casework components are removed, during upgrade work for example, ensure that all metal parts are correctly re-assembled and all internal and external screws are re-fitted and correctly tightened.

Power Connection

Typical AC plugs

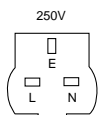

BS1363A

U. K.

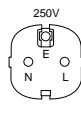

SHUCO

Austria Belgium
Finland France
Italy Germany
Sweden Norway
Holland

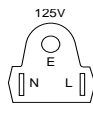

NEMA 5-15P

Taiwan
Thailand
Japan
USA
Canada

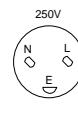

SRAF 1962/DB16/87

Denmark

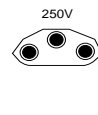

ASE 1011

Switzerland

Checking the AC power supply

When this product is delivered, it is ready for the commercial AC power supply generally available in the country in which it is first sold. It has been set for the correct voltage range, and is supplied with an AC power cord and plug which comply with the relevant safety standards.

Before using the product in a country other than that in which it was originally sold, you must check the voltage and frequency of that country's AC power supply, and the type of power cord required there. Check the power rating labels on the rear of the computer's system unit and its monitor to ensure that they are compatible with the AC power supply.

SAFETY & REGULATORY NOTICES

The computer can function within two alternative AC power supply ranges:

AC power supply (voltage and frequency)

100 - 120 Volt AC, 50 - 60 Hz

200 - 240 Volt AC, 50 - 60 Hz

The voltage setting of the monitor must always be the same as the voltage setting of the system unit. See the *User's Guide* that accompanies the monitor or consult your supplier to find out how to change the voltage setting.

CAUTION

It is imperative that the computer is set to the correct voltage range before use. If not, the machine may be irreparably damaged.

Connecting to the AC power supply

IMPORTANT

Any peripheral equipment that requires an AC power cord must be earthed.

Use the following guidance to connect the components together. It is important that you take each step in the order indicated.

1. Before connecting any components, ensure that the AC power supply is switched off or disconnected, and that the system unit, the monitor, and any peripherals are turned off.
 2. Connect the component signal cables to their respective ports on the system unit: keyboard, mouse, monitor, audio (where appropriate) and any other peripherals.
 - ◇ Where appropriate, connect the computer to the network.
 3. Connect the component power cords: system unit, monitor to system, plus any other peripherals to nearby, grounded AC power outlets. (Never substitute a power cord from any other appliance). Then switch on or connect the AC power supply.
 4. Turn on the system unit first, then the monitor, then other peripherals.
-

WARNING

The Handbook contains procedures which require opening of the system unit. Ensure all cables (including modem and network cables) are disconnected before the system unit is opened.

Power Cable Connections - UK ONLY

This equipment is supplied with an AC power cord that has a non-removable moulded plug.

Always replace the fuse with one of the same type and rating which is BSI or ASTA approved to BS1362. Always refit the fuse cover, never use the plug with the fuse cover omitted.

External Speakers (where supplied)

Always switch off or disconnect the AC supply before disconnecting any of the speaker leads, whether audio or power. Disconnect the AC supply from the speaker power unit when not in use for any period of time.

To prevent the risk of electric shock, do not remove speaker covers.

Connecting the speaker power cord to any other cords or joining cords together can cause fire and risk of electric shock.

1 SYSTEM INTRODUCTION

The FT5000 server is designed to either stand upright (pedestal mode) or be mounted in a rack (rack mode). Figures below show examples of these configurations. Before operation, you must configure the server for one of the two modes. (As standard the FT5000 is fitted with the pedestal mountings, but a separate rack mounting kit is available).

If you require a rack mounting kit and have not already purchased one, contact your Mitsubishi Electric supplier for details. For installation in an equipment rack, see the 'FT5000 Rack Mounting Guide' booklet for full information.

Server physical specifications

<i>Specification</i>	<i>Pedestal Mode</i>	<i>Rack Mode</i>
Height	48.26 cm (19 inches)	7u
Width	31.12 cm (12.25 inches)	19 inch rack
Depth	63.5 cm (25 inches)	63.5 cm (25 inches)
Weight	38.25 kg minimum configuration 45 kg maximum configuration	38.25 kg minimum configuration 45 kg maximum configuration
Required front clearance	25 cm (inlet airflow <35 °C / 95 °F)	25 cm (inlet airflow <35 °C / 95 °F)
Required rear clearance	25 cm (no airflow restriction)	25 cm (no airflow restriction)
Required side clearance	None, but side clearance required for service	N/A

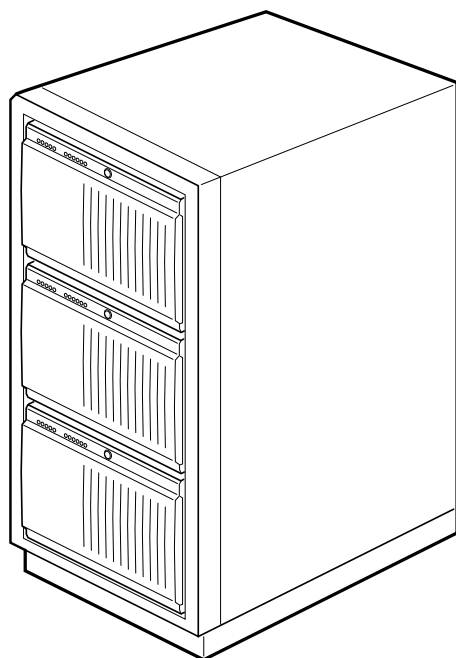

Typical rack with three servers

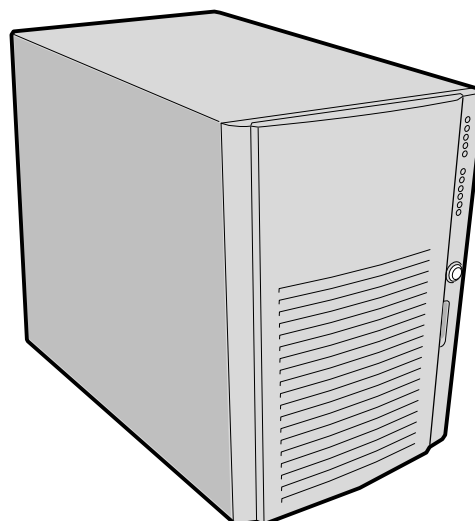

Single server in pedestal mode

OM08000

Chassis feature summary

Feature	Description
Controls	All main system controls are behind a lockable front door which can be protected within the system overall security (see the information later in this chapter and in the 'Configuration' chapter). All removable media drives, (Floppy diskette drive, CD-ROM drive etc.) are also behind this door).
Drives	Installed: 1.44 MB diskette drive, accessible from front subchassis. Expansion capacity: Two 5.25-inch-wide bays that are externally accessible, designed to hold half-height standard removable media devices; the bays can be converted into a single full-height bay.
Hard disk drives	A front opening hard disk drive bay can accommodate up to 6 standard 3.5 inch single-ended SCSI hard drives. They can be hot-swapped in the event of drive failure. The whole drive bay can be padlocked to help prevent unauthorised access. The locked door is then behind the system door which can be protected within the system overall security (see the information later in this chapter and in the 'Configuration' chapter).
Expansion slot covers	Up to eight slot covers can be used; every slot opening that does not have an add-in board installed must have a slot cover installed.
Mainboard	Form-factor, 40.5 cm × 33 cm, ATX I/O.
Power supply	Up to three 400-watt power supplies with integrated cooling fans and detachable AC power cords.
Cooling	Up to 11 fans provide cooling and airflow: three system fans inside the chassis (and three more needed only for redundant cooling), one fan for each power supply (up to three), and two fans for cooling hard drives.

Environmental specification

Temperature	
Nonoperating	-40° to 70 °C
Operating	10° to 35 °C; derated 0.5 °C for every 305 m Altitude to 3000m max; maximum rate of change = 10°C per hour
Humidity	
Nonoperating	95% relative humidity (noncondensing) at 30 °C
Operating wet bulb	Not to exceed 33 °C (with diskette drive or hard disk drive)
Shock	
Operating	2.0 g, 11 msec, 1/2 sine
Packaged	Operational after 30-inch free fall (cosmetic damage might occur)
Acoustic noise	< 47 dBA with one power supply at 28 °C +/- 2 °C < 50 dBA with two power supplies at 28 °C +/- 2 °C < 55 dBA with three power supplies at 28 °C +/- 2 °C
Electrostatic discharge (ESD)	Tested to 20 kilovolts (kV) per Intel environmental test specifications; no component damage
AC Input Power	
100 - 120 VAC	100 - 120 VAC, 7.6 A, 50 - 60 Hz
200 - 240 VAC	200 - 240 VAC, 3.8 A, 50 - 60 Hz

Chassis front controls and indicators

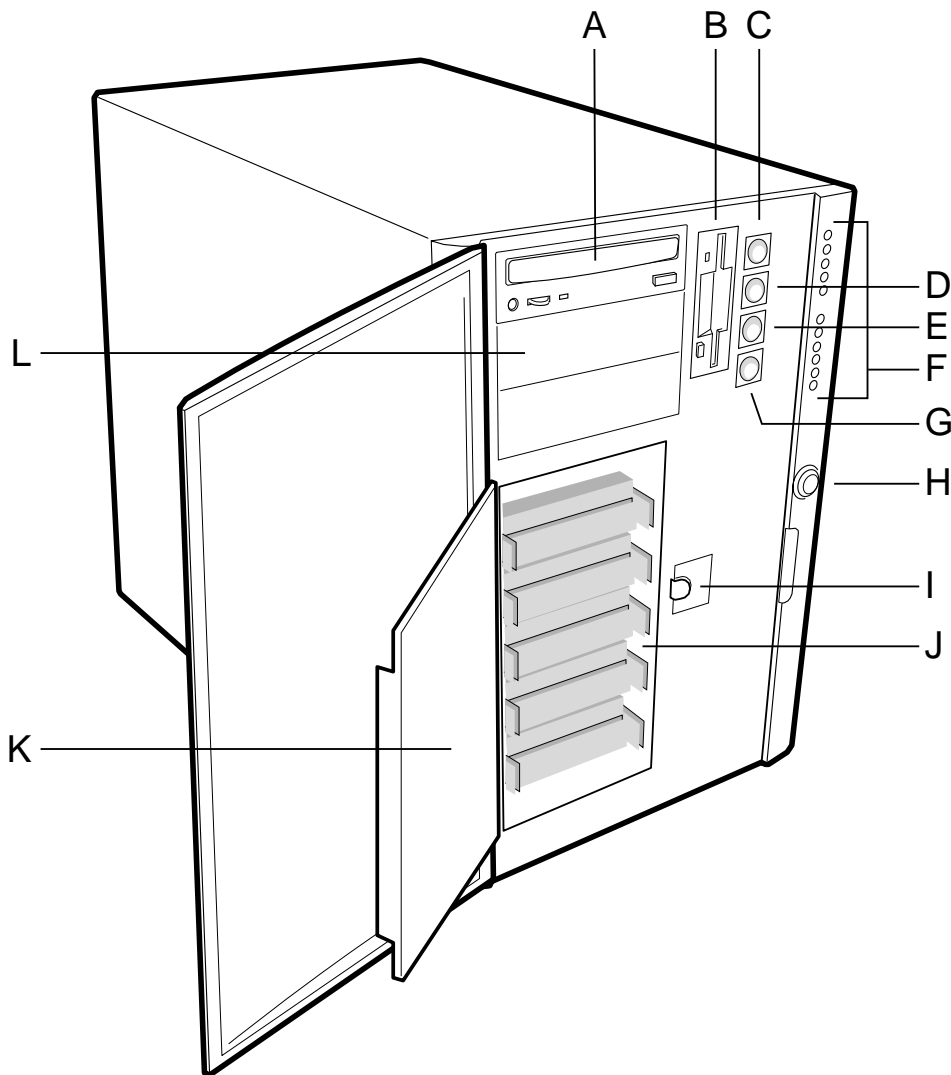

- A. External drive bays; CD-ROM drive shown installed
- B. Diskette drive
- C. Power On/Off button (holding down this button for more than four seconds causes a power-button override to the PIIX4E when you release the button)
- D. Sleep/Service button (holding down this button for LESS THAN four seconds enters sleep mode, which requires an ACPI-compliant OS; holding it down for MORE THAN four seconds enters service mode, which powers down the electronics bay but leaves hot-swap and peripheral bays running)
- E. Reset button
- F. Front panel LEDs (Top to bottom: top five are power on, disk bay power on, HDU activity, fan failure, power supply failure; bottom six are hard-drive activity LEDs, labeled 0-5)
- G. NMI button
- H. System security lock
- I. EMI shield lock
- J. Internal drive bays
- K. Metal EMI shield
- L. Expansion drive bay

Chassis back controls and features

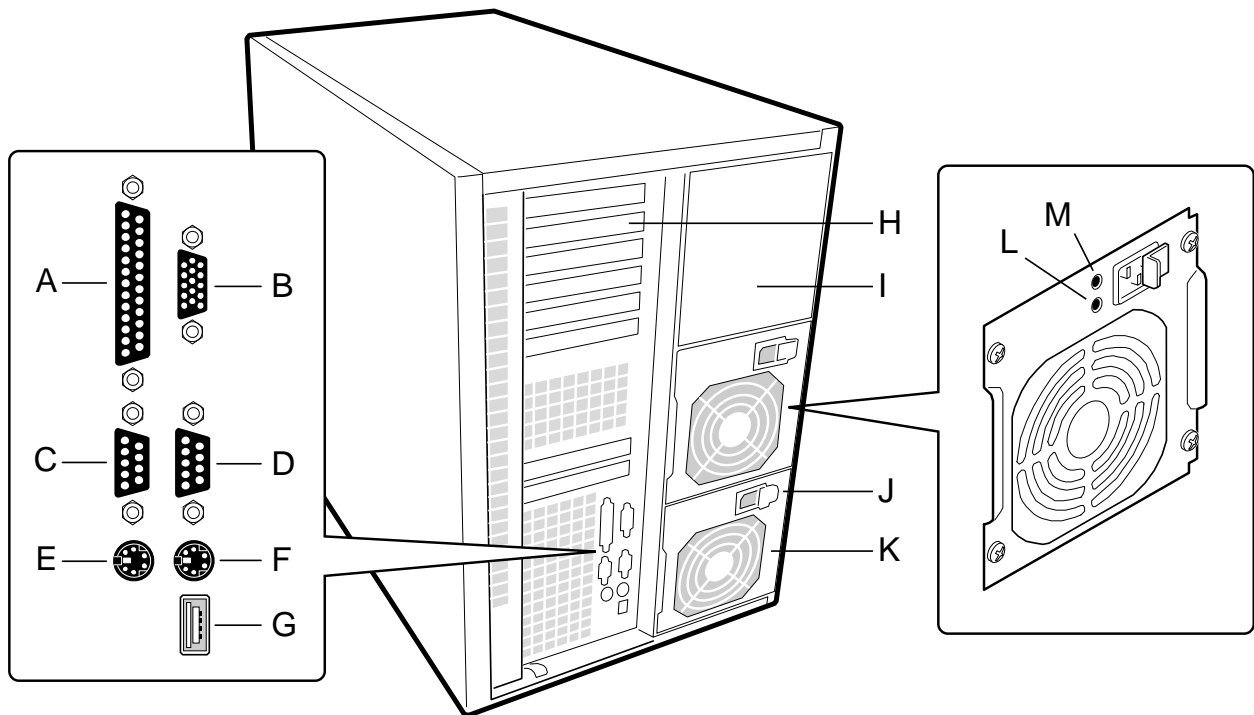

- A. Parallel port
- B. VGA monitor connector
- C. Serial port A, COM1
- D. Serial port B, COM2 (extended via ribbon cable from back panel to baseboard)
- E. Mouse connector
- F. Keyboard connector
- G. Universal serial bus connector
- H. Expansion slot covers (six slot connectors provided on baseboard)
- I. Power supply bay
- J. AC input power connector
- K. Power supply fan
- L. Power supply LED
- M. Power supply failure LED (LED not lit means failure)

Expanded side view

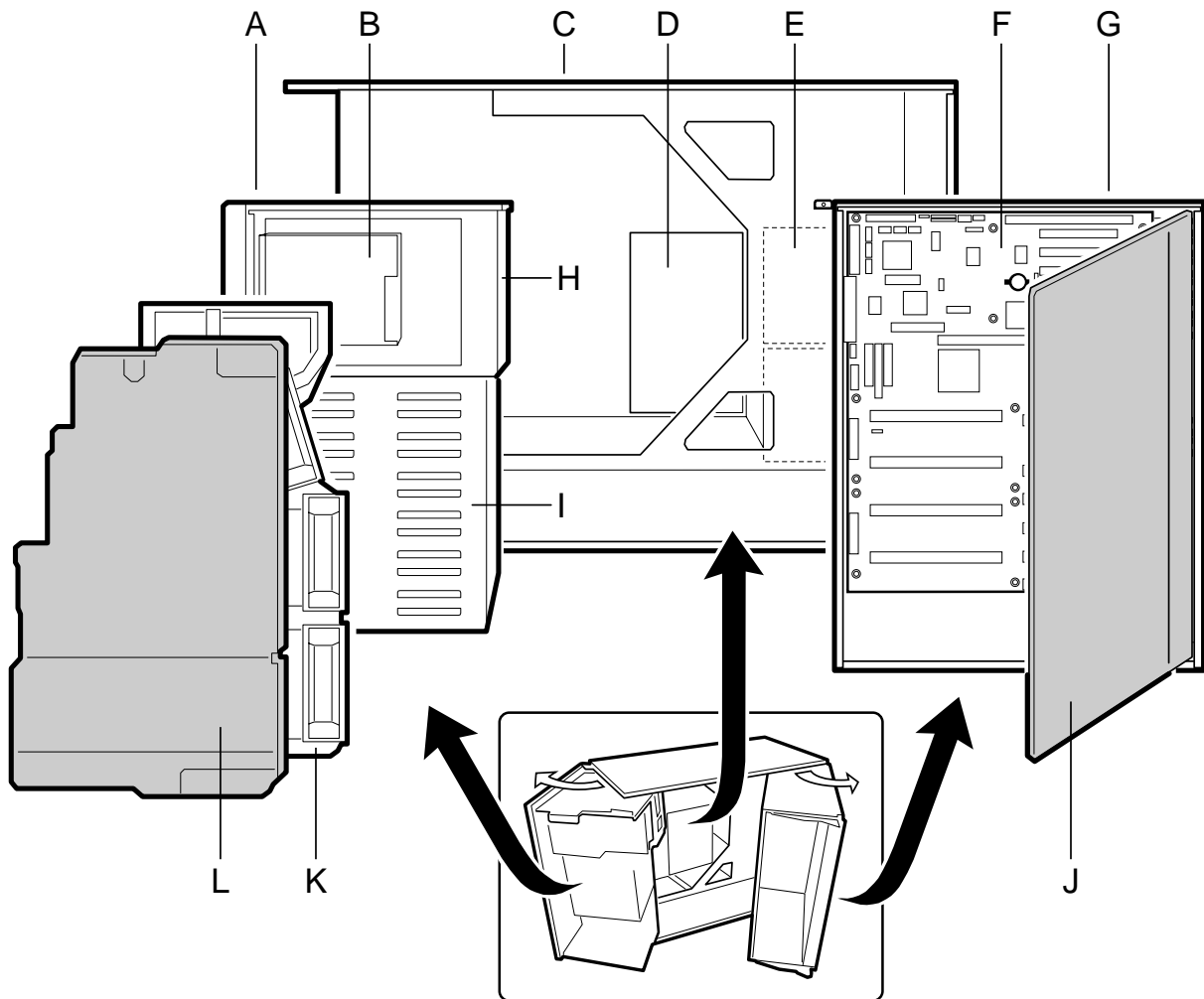

- A. Front swing-out subchassis
- B. Diskette drive
- C. Main chassis
- D. Power backplane
- E. Power supply(s)
- F. Mainboard
- G. Lift-out electronics bay
- H. Removable media device bay
- I. SCSI hard drive bay
- J. Foam cover
- K. Foam fan housing
- L. Foam fan housing cover

Peripherals

3.5-inch diskette drive

The 3.5-inch diskette drive in the 3.5-inch peripheral bay supports 720 KB, and 1.44 MB media. The drive is externally accessible from the front of the system.

Internal 3.5-inch hard drive bays

The chassis contains one bay for two 3.5-inch-wide (1" high or 1-5/8" high) LVDS SCSI hard drives with internal cabling. An optional hot-swap-capable backplane can accommodate six 3.5-inch-wide (1" high) or three 3.5-inch (1-7/8" high) hard drives, which are accessed from the lower front of the system.

As part of the hot-swap implementation, a drive carrier is required. The drives are mounted in the carrier with four fasteners and the carrier snaps into the chassis. Carriers with heatsinks are available for high-power drives that require extra cooling.

A single metal EMI shield and plastic door cover the drive bays. A hot-docking bay is provided for drives that are 3.5 inches wide and 1 inch high. Drives can consume up to 22 watts of power and must be specified to run at a maximum ambient temperature of 55 °C.

The system was designed to allow the user to install a Redundant Array of Independent Disks (RAID). A software implementation with onboard SCSI or an add-in board can be used to set up RAID applications.

External bays for 5.25-inch removable media devices

The chassis has two 5.25-inch half-height bays that are accessible from the front of the system. These bays are intended to provide space for tape backup or other removable devices.

You can convert the 5.25-inch bays to a single full-height bay. It is recommend that you do NOT install hard drives in these bays as they cannot be properly cooled or shielded. A hard drive generates EMI and is therefore more susceptible to damage in this location.

Power supplies

The chassis can be configured with one, two, or three 400-watt power supplies, each designed to minimise EMI and RFI. Each supply operates within the following voltage ranges and is rated as follows:

- ◆ 100 - 120 VAC at 50 - 60 Hz; 7.6 A maximum
- ◆ 200 - 240 VAC at 50 - 60 Hz; 3.8 A maximum

The DC output voltages of each power supply are as follows:

- ◆ +3.3 V at 36 A max
- ◆ +5 V at 24 A max (total combined output of +3.3 V and +5.5 V not to exceed 195 W)
- ◆ +12 V at 18.0 A with 19.0 A <10ms peak
- ◆ +24 V at 50mA
- ◆ -12 V at 0.5 A
- ◆ +5 V standby 1.5 A

Power is routed through the power cable to the 20-pin main connectors on the baseboard. Remote sensing signals are provided through the cable to the 14-pin auxiliary connector on the baseboard.

System security

To help prevent unauthorised entry or use of the system, the system includes a three-position key lock/switch to permit selected access to drive bays (position is communicated to BMC). The system also includes server management software that monitors the chassis intrusion switch.

Mechanical locks and monitoring

The system includes a chassis intrusion switch. When the access cover is opened, the switch transmits an alarm signal to the mainboard, where server management software processes the signal. The system can be programmed to respond to an intrusion by powering down or by locking the keyboard, (for example).

Software locks via the SSU or BIOS Setup

The SSU provides a number of security features to prevent unauthorised or accidental access to the system. Once the security measures are enabled, access to the system is allowed only after the user enters the correct password(s). For example, the SSU allows you to:

- ◆ Enable the keyboard lockout timer so the server requires a password to reactivate the keyboard and mouse after a specified time-out period of 1 to 120 minutes
- ◆ Set and enable administrator and user passwords
- ◆ Set secure mode to prevent keyboard or mouse input and to prevent use of the front panel reset and power switches
- ◆ Activate a hot-key combination to enter secure mode quickly
- ◆ Disable writing to the diskette drive when secure mode is set

Using passwords

If you set and enable a user password but not an administrator password, enter the user password to boot the system and run the SSU.

If you set and enable both a user and an administrator password:

- ◆ Enter either one to boot the server and enable the keyboard and mouse
- ◆ Enter the administrator password to access the SSU or BIOS Setup to change the system configuration

Secure mode

Configure and enable the secure boot mode by using the SSU. When secure mode is in effect, you:

- ◆ Can boot the system and the OS will run, but you must enter the user password to use the keyboard or mouse
- ◆ Cannot turn off system power or reset the system from the front panel switches

Secure mode has no effect on functions enabled via the Server Manager Module or power control via the real-time clock (RTC).

Taking the system out of secure mode does not change the state of system power. That is, if you press and release the power switch while secure mode is in effect, the system will not power off when secure mode is later removed. However, if the front panel power switch remains depressed when secure mode is removed, the system will power off.

Software security features

Feature	Description
Put the system into secure boot mode	<p>How to enter secure mode:</p> <p>Setting and enabling passwords automatically puts the system into secure mode.</p> <p>If you set a hot-key combination (through the SSU or Setup), you can secure the system simply by pressing the key combination. This means you do not have to wait for the inactivity time-out period.</p> <p>When the system is in secure mode:</p> <p>The system can boot and run the OS, but mouse and keyboard input is not accepted until the user password is entered.</p> <p>At boot time, if a CD is detected in the CD-ROM drive or a diskette in drive A, the system prompts for a password. When the password is entered, the system boots from CD or diskette and disables the secure mode.</p> <p>If you have not yet installed a CD-ROM drive, if there is no CD in the drive or diskette in drive A, the system boots from drive C and automatically goes into secure mode. All enabled secure mode features go into effect at boot time.</p> <p>To leave secure mode:</p> <p>Enter the correct password(s).</p>
Disable writing to diskette	In secure mode, the system will not boot from or write to a diskette unless a password is entered. To set these features, see the information given in the 'Configuration' chapter.
Disable the power and reset buttons	If this protection feature is enabled by the SSU, the power and reset buttons are disabled when in secure mode.
Set a time-out period so that keyboard and mouse input are not accepted	You can specify and enable an inactivity time-out period of from 1 to 120 minutes. If no keyboard or mouse action occurs for the specified period, attempted keyboard and mouse input will not be accepted. To set this feature, see the information given in the 'Configuration' chapter.
Also, screen can be blanked and writes to diskette can be inhibited	If video blanking is enabled, the monitor display will go blank until the correct password(s) is entered. To set this feature, see the information given in the 'Configuration' chapter.
Control access to using the SSU: set administrator password	<p>To control access to setting or changing the system configuration, set an administrator password and enable it through Setup or the SSU.</p> <p>If both the administrator and user passwords are enabled, either can be used to boot the system or enable the keyboard and/or mouse, but only the administrator password allows changes to Setup and the SSU.</p> <p>Once set, passwords can be disabled by setting the password to a null string or by changing the Clear Password jumper. See the information given in the 'Configuration' chapter; or, to change a jumper, see the information given in the 'Mainboard' chapter.</p>
Control access to the system other than SSU: set user password	<p>To control access to using the system, set a user password and enable Password on Boot through Setup or the SSU.</p> <p>Once set, passwords can be disabled by setting the password to a null string or by changing the Clear Password jumper. See the information given in the 'Configuration' chapter; or, to change a jumper, see, the information given in the 'Mainboard' chapter.</p>
Boot without keyboard	<p>The system can boot with or without a keyboard. Before the system boots during POST, BIOS automatically detects and tests the keyboard, if present, and displays a message. No entry exists in the SSU for enabling or disabling a keyboard.</p> <p>Do not plug in a keyboard while power is applied to the system.</p>
Specify the boot sequence	The sequence you specify in the 'Boot device priority submenu' (see the 'Configuration' chapter) determines the boot order. If secure mode is enabled (user password is set), you will be prompted for a password before the system boots fully. If secure mode is enabled and the 'Secure mode boot' option is also enabled, (see 'Security menu' in the 'Configuration' chapter) the system boots fully but requires a password before accepting any keyboard or mouse input.

2 WORKING INSIDE THE SYSTEM

Tools and supplies needed

- × Phillips (cross-head) screwdriver (#1 and #2 bit).
- × Small flat-bladed screwdriver.
- × Jumper removal tool or needle-nosed pliers.
- × Antistatic wrist strap and conductive foam pad (recommended).
- × Pen or pencil.
 - Equipment log: as you integrate new parts into the system, add information about them to your equipment log, at the back of the handbook. Record the model and serial number of the system, all installed options, and any other pertinent information specific to the system. You will need this information when running the SSU.

Safety: before you remove the access cover

Before removing the access cover at any time to work inside the system, observe these safety guidelines.

1. Turn off and disconnect **all** peripheral devices connected to the system.
2. Turn off the system by using the push-button on/off power switch on the front of the system.
3. Unplug the AC power cords from the system or wall outlet.
4. Use full antistatic precautions as given in the *Safety & Regulatory Notices* at the front of this handbook.

Warnings and cautions

These warnings and cautions apply whenever you remove the access cover of the system or remove any components from it. Only an authorised engineer or other suitably qualified technical person should attempt to integrate and configure the system.

- × **System power on/off:** The on/off button on the front panel DOES NOT turn off the system AC power. To remove power from system, you must unplug the AC power cords from the wall outlet or the system.
- × **Hazardous conditions, power supply:** Hazardous voltage, current, and energy levels are present inside the power supply. There are no user-serviceable parts inside it.
- × **ESD and handling boards:** Always handle boards carefully. They can be extremely sensitive to ESD. Hold boards only by their edges. Do not remove boards from their protective wrapper until you are ready to put it straight into the system.
- × **Cooling and airflow:** For proper cooling and airflow, always install the chassis access cover before turning on the system. Operating it without the cover in place may damage system components.
- × **Avoid personal injury:** To avoid personal injury when unpacking the server, use a mechanical assist unit to lift it off the shipping pallet. The minimum server configuration weighs 38 kg; the maximum weighs 45 kg.
 - Do not attempt to lift or move the server by the handles on the power supplies.
 - Use a hand-truck or other mechanical assist unit to move the server from one location to another, or to raise it into position for rack mounting.

Access cover

Removing the access cover

You need to remove the system access cover, and in some cases the front bezel, to reach components inside the system. Facing the front of the system, the access cover is on the right side for pedestal-mounted (tower) servers, and on the top for rack-mounted servers.

1. Observe the precautions as given in *Safety & Regulatory Notices* at the front of this handbook.
1. Turn off and disconnect **all** peripheral devices connected to the system.
2. Turn off the system by using the power on/off switch on the front panel AND unplug all AC power cords.
3. Remove and save the two screws from the back of the access cover; you will need them later to reattach the cover.
4. Place the fingertips of your right hand under the built-in handle on the back of the cover. A rounded, rectangular depression in the front middle of the access cover serves as another handle.
5. Using an even pull, slide the cover backward, about 2 to 3cm, until it stops.
6. Pull the entire cover outward, straight away from the chassis, to disengage the rows of tabs from the notches in the top and bottom edges of the chassis. Set the cover aside.

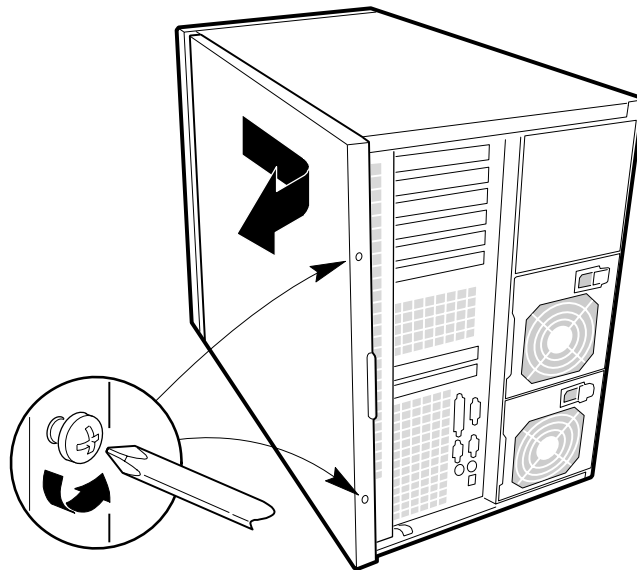

Installing the access cover

1. Before replacing the access cover, check that you have not left loose tools or parts inside the system.
2. Check that cables, add-in boards, and other components are properly installed.
3. Position the cover over the chassis so that the rows of tabs align with slots in the chassis. Slide the cover toward the front of the system until the tabs on the cover firmly engage in the chassis.
4. Attach the cover to the chassis with the two screws you removed earlier, and tighten them firmly.
5. Connect all external cables and the power cords to the system.

Subchassis and electronics bay

The chassis is comprised of three parts: the main chassis, a swing-out subchassis at the front, and a swing-out subchassis, called the electronics bay, at the rear. To access components in some instances, you must swing away and/or completely remove the subchassis and electronics bay.

1. Observe the precautions as given in *Safety & Regulatory Notices* at the front of this handbook.
2. Turn off and disconnect **all** peripheral devices connected to the system.
3. Turn off the system power by using the power on/off switch on the front panel AND unplug all AC power cords.
4. Remove and save the two screws from the back of the access cover; you will need them later to reattach the cover.
5. Remove the access cover.
6. Loosen screws on the top and bottom edges of the chassis (A) in the illustration below. These screws attach the front subchassis and the electronics bay to the main chassis.

WARNING

You must disconnect all cabling to the electronics bay before rotating/removing the bay. Failure to do so can result in serious damage to system components. The location of the main connectors in the electronics bay is marked as D in the illustration below.

7. Rotate the front subchassis left, away from the main chassis, until it stops (B).
8. Disconnect all cabling to the electronics bay (D).
9. Using the vertical edge of the electronics bay as a handle, rotate the bay right, away from the main chassis, until it stops (C).
10. If necessary, completely remove the subchassis and electronics bay: rotate the bays outward until the two pins that function as hinges for the bays slide out of their slots.

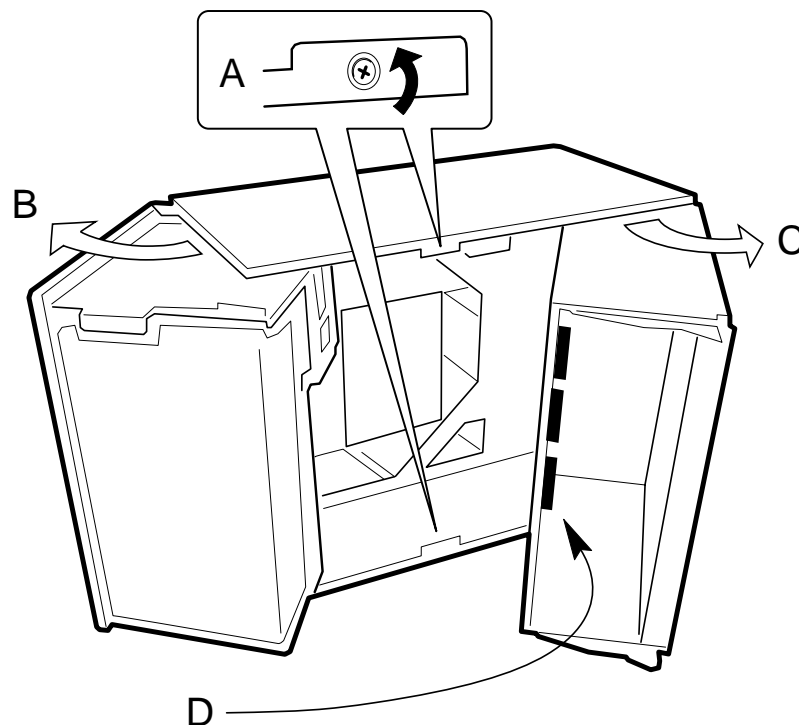

Add-in boards

Installing an add-in board

1. Remove access cover as detailed in the previous section.
2. Remove add-in board from its protective wrapper. Be careful not to touch the components or gold edge connectors. Place board component-side up on an antistatic surface.
3. Record the serial number of the add-in board in your equipment log.
4. Set jumpers or switches according to the manufacturer's instructions.
5. Remove and save the expansion slot cover from the chosen slot.
6. Hold the add-in board by its top edge or upper corners. Firmly press it into an expansion slot on the baseboard. The tapered foot of the board retaining bracket must fit into the mating slot in the expansion slot frame.
7. Slide the notch at the top of the retention bracket into its receptacle on the frame, which is above and perpendicular to the top expansion slot.
8. Reinstall the access cover using the original screws.

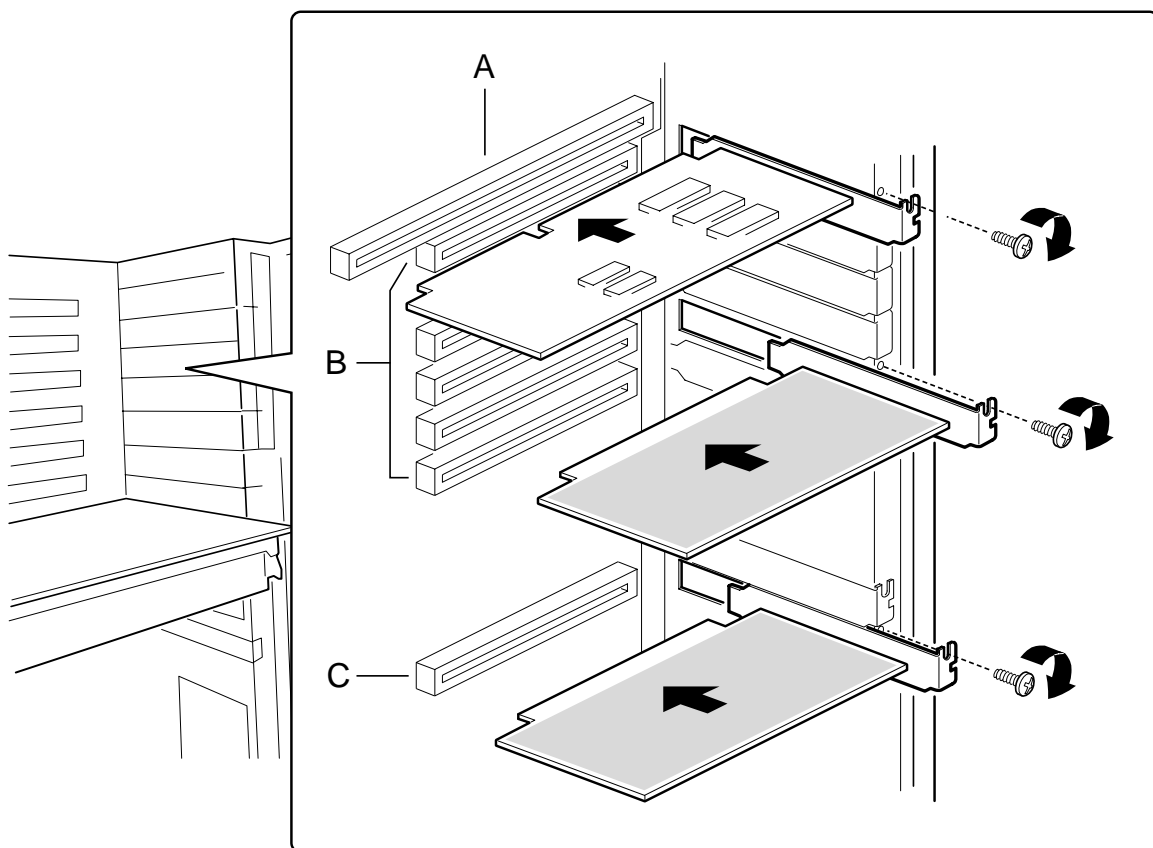

- A. ISA slot (USE HALF-LENGTH BOARD ONLY)
B. Six PCI slots (top to bottom in figure = PCI B3, B2, B1, B0, A3, and A2)
C. PCI slot A1

Installing a 5.25-inch peripheral in the front bay

The system already has a CD-ROM drive installed, but you can add other devices, such as a tape drive. It is recommend that you do NOT install hard drives in these bays as they cannot be properly cooled or shielded. A hard drive generates EMI and is therefore more susceptible to damage in this location.

CAUTIONS

Only single-ended SCSI devices supported: The internal SCSI interface in this system supports only single-ended SCSI devices. Connecting differential SCSI drive types to this interface can result in electrical damage to the baseboard and peripherals.

NOTES

Save the filler panels and EMI shields: System EMI integrity and cooling are both protected by having drives installed in the bays or filler panels and EMI shields covering the bays. When you install a drive, save the panel and shield to reinstall in case you should later remove the drive and not reinstall one in the same bay.

- **Bus termination when installing SCSI devices:** It is important that your cabling and connections meet the SCSI bus specification. Otherwise, the bus could be unreliable and data corruption could occur or devices might not work at all. The SCSI bus needs to be terminated at the end of the cable; this is usually provided by the last SCSI device on the cable
1. Observe the precautions as given in *Safety & Regulatory Notices* at the front of this handbook.
 2. Open the front bezel by rotating its right side out and to the left.
 3. Push the tab (A) on the left side of the EMI metal shield to the right to disengage it from the chassis. Save the shield.

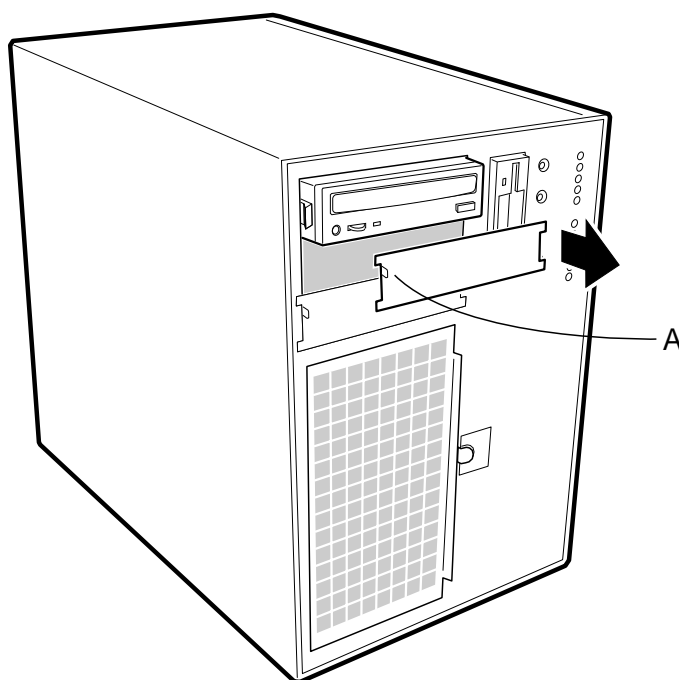

4. Remove the drive from its protective wrapper, and place it on an antistatic surface.

Working inside the system

5. Record the drive model and serial numbers in your equipment log at the rear of the handbook.
6. Set any jumpers or switches on the drive according to the drive manufacturer's instructions.
7. Using two screws of the appropriate size and length (not supplied), attach each plastic slide rail with its metal grounding plate to the drive.

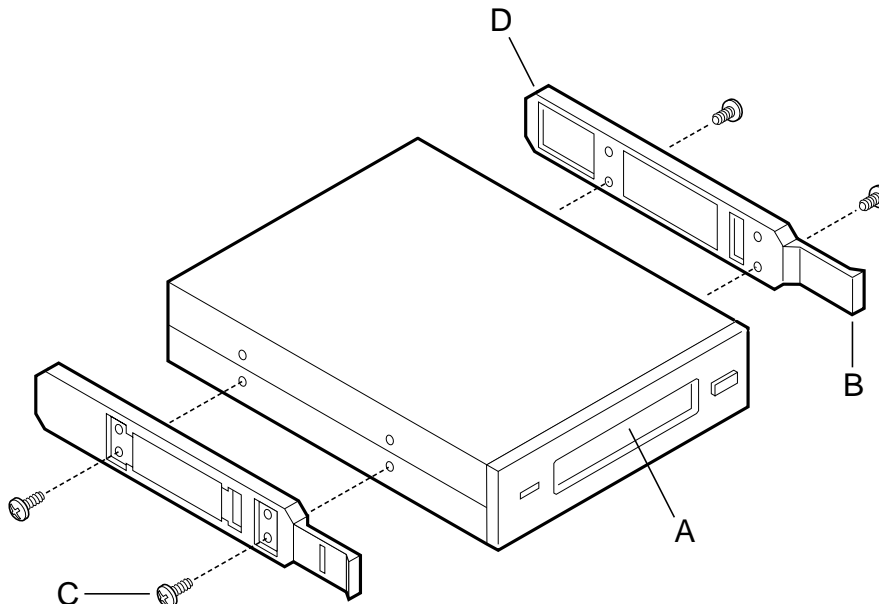

- A. Tape drive or other removable media device
 - B. Tab on slide rail
 - C. Screws (4)
 - D. Slide rails (2)
8. Position the drive so the plastic slide rails engage in the bay guide rails. Push the drive into the bay until the slide rails lock in place.
 9. Connect a power cable to the drive. The connectors are keyed and can be inserted in only one way.
 10. Connect a signal cable to the drive. The connectors are keyed and can be inserted in only one way.
 - **SCSI drive:** Attach connectors on the cable to the SCSI device or devices you are installing.
 - **IDE drive:** The baseboard has one IDE connector.
 11. Close the front bezel.

Fans

The FT5000 server contains five removable chassis fans (and can accept up to three more) to cool the boards and removable media drives. These chassis fans connect to the front panel board and are enclosed in a removable foam assembly. The integrated power supply fan(s) provides more cooling and airflow.

Removing the system fan assembly

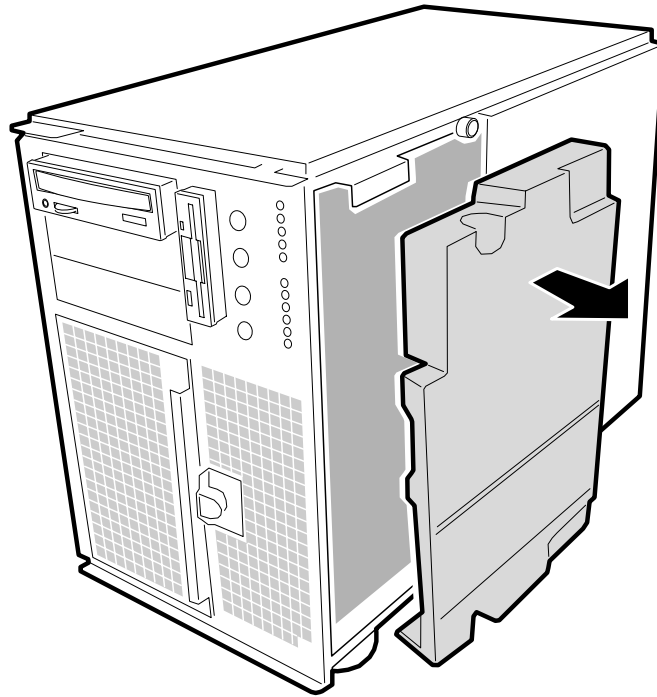

1. Observe the precautions as given in *Safety & Regulatory Notices* at the front of this handbook.
2. Remove the access cover as previously detailed.
3. Remove the foam cover from the front subchassis by pulling it straight out as above. For better access to the individual fan cables on the front panel board, carefully rotate the right edge of the foam fan assembly outward into the opening where the foam cover was.
4. Label and disconnect the individual fan cables from the front panel board. For fan cabling considerations, see page.
5. Remove the fan assembly from the chassis.

Removing an individual system fan

NOTE

Correct airflow direction: The side of each fan is embossed with directional arrows indicating airflow direction. Always note the direction of the arrows on a fan before removing it. Contact your Mitsubishi dealer for suitable replacement fans.

1. Observe the precautions as given in *Safety & Regulatory Notices* at the front of this handbook.
2. Remove the access cover as previously detailed.

Working inside the system

3. Remove the foam cover from the front subchassis by pulling it straight out as shown above. Be careful not to break the foam.
4. For better access to the individual fan cables on the front panel board, carefully rotate the right edge of the foam fan assembly outward into the opening where the foam cover was.
5. Label and disconnect the desired fan cable from the front panel board. Be sure to note the position of the cable where it is held in place in the foam fan assembly.
6. Remove the fan cable from the foam assembly, being careful not to break the foam.
7. Remove the fan from the foam assembly. All systems fans sit differently in the assembly, but in general, each fan can slide in and out of the foam in only one way.

The two installed fans nearest the 5.25-inch drive bays (fans 6 and 7 below) are separated by a square piece of foam (the piece with a crescent-shaped hole) that extends perpendicularly from the front of the fans, it is the rectangle between the round faces of fans 6 and 7). You must remove this piece to access the two fans it separates (pull it straight out).

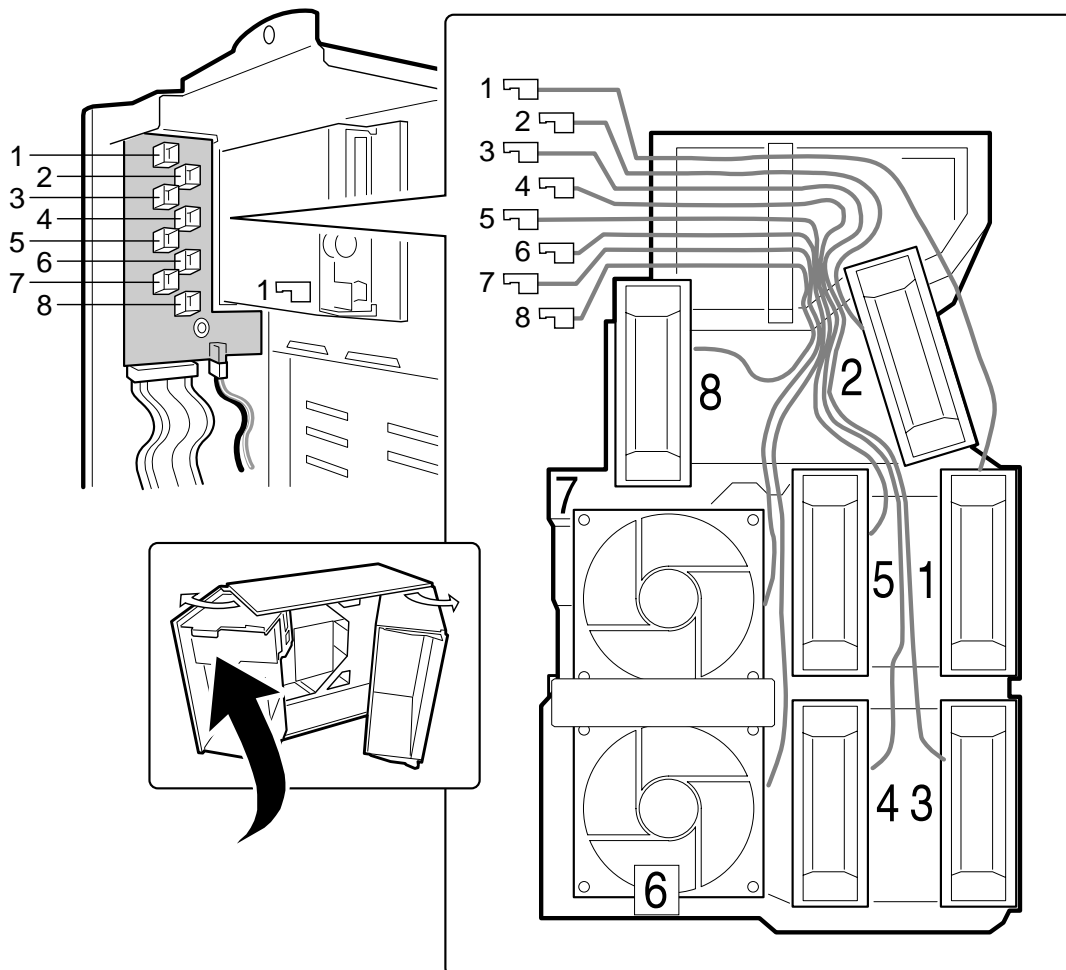

3 EXCHANGING SCSI HARD DRIVES

SCSI hard disk drives

The system supports a variety of single-ended SCSI devices. As shipped, the system might contain only one hard disk drive. Contact your Mitsubishi Electric dealer for a list of approved and compatible single-ended SCSI devices.

WARNING

The single-ended SCSI backplane requires installing single-ended SCSI devices in your system. Installing differential SCSI drive types can result in electrical damage to the baseboard and the peripherals.

CAUTION

Electrostatic discharge (ESD) and ESD protection: ESD can damage disk drives, add-in boards, and other components. This server can withstand normal levels of environmental ESD while you are hot-swapping SCSI hard disk drives. However, we recommend doing all procedures in this manual only at an ESD-protected workstation. If one is not available, you can provide some ESD protection by wearing an antistatic wrist strap attached to chassis ground of the server—an unpainted metal surface—when handling any components.

Mounting a SCSI hard disk drive in a plastic carrier

1. Remove the 3.5-inch hard drive from its wrapper and place it on an antistatic surface.
2. Record the drive model and serial number in your equipment log
3. Orient the drive so the connector is near the top surface of the drive, then place the plastic carrier on top of the drive.
4. Using four screws of the correct size and length (not supplied), attach the carrier to the drive.

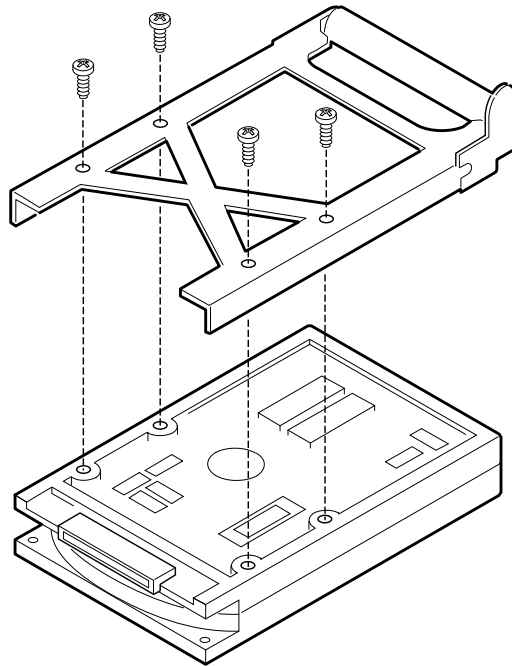

Hot-swapping a SCSI hard disk drive

CAUTION

It is vital that you remember the exact cable and connector arrangement of your hard disks, particularly if you are using a RAID (Redundant Array of Independent Disks) configuration. If you fail to restore the arrangement so that all cables, plugs and disks are as they were originally, you risk losing all the data on your hard disks.

A bank of six yellow LEDs on the front panel monitors the drive status of each drive in the upper and lower hot-docking bays. Each LED corresponds directly to a drive, so that the upper-most LED reflects activity in the upper-most drive. The six LEDs and corresponding drives are numbered (top to bottom) 'zero' to 'five'. When a yellow LED is on continuously, it is okay to hot-swap (replace) a bad drive with a good one. You DO NOT need to shut the system down to hot-swap a drive.

1. Open the front bezel by rotating its right side out and to the left.
2. If you installed a padlock on the metal door to the bays, unlock the padlock and remove it.
3. Loosen the plastic latch securing the metal door to the chassis, and open the door.
4. Check the bank of yellow LEDs on the front panel to determine which drive is bad.
5. Press the rounded tab on the right of the carrier to the left (toward the center of the drive)—(B) in illustration below, while gently pulling straight down on the carrier handle (A). This disengages the latch that secures the carrier to the chassis.
6. Grasp the plastic carrier handle and pull it toward you to disengage the drive connector from the backplane connector.

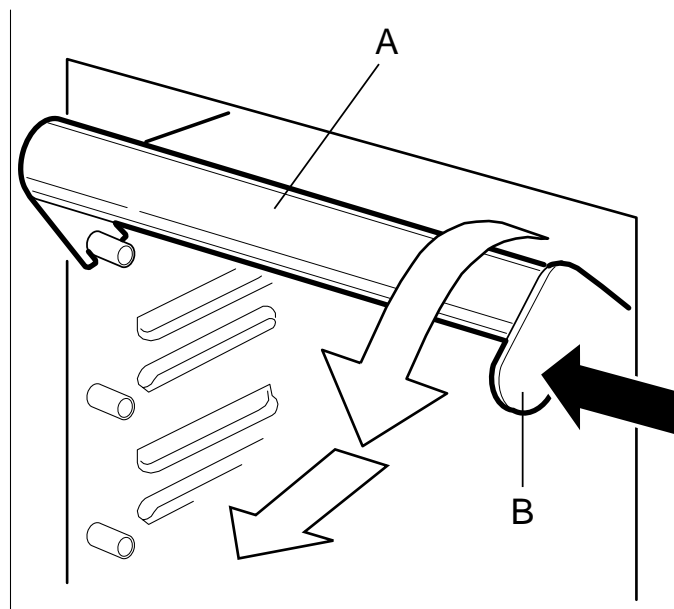

- A. Carrier handle (pull straight down to disengage carrier and bay from backplane connector)
- B. Tab on carrier handle (push left to unlock carrier)
7. Carefully slide the bad drive forward out of the bay. Place the drive on an antistatic surface.
8. Position the new plastic carrier and drive assembly so that it engages the bay guide rails.

CAUTION

It may be wise to keep a separate written record in the log sheet, at the rear of this book, of which trays are fitted with drives, along with their specification. Update this record with any changes or additions.

9. Gently push the drive into the bay. To engage the latch, the carrier handle should be approximately at a 45° angle from the vertical front of the chassis. As you push the drive into the bay, the two rounded notches in the carrier handle (B) in illustration below, slide onto the two round pegs inside the drive bay (A). When they engage, push the handle straight up (C) to lock the notches onto the pegs and press the rounded tab on the right of the carrier to the left until it clears the edge of the bay and snaps into place.

NOTE

Since the hard disk drives for your Mitsubishi server are exclusively SCSI drives, it is important to note that the SCSI connector on the backplane of the drive module contains the device address. This means that, for a given connector, any disk drive that is fitted to that connector will have the same SCSI address.

10. Close the metal door, and secure it to the chassis with the plastic latch.
11. For security and to prevent unauthorised access to the bays, insert a padlock through the metal loop protruding through the door.
12. Close the front bezel.

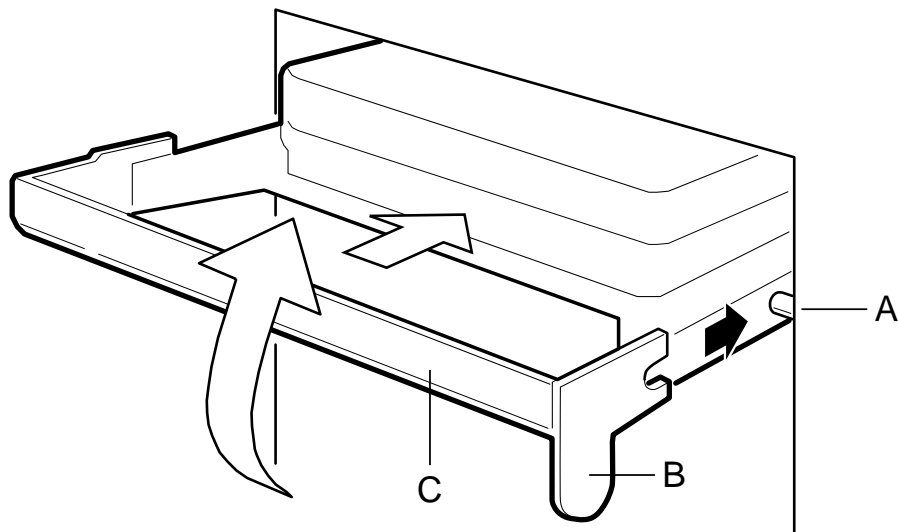

- A. Round peg inside drive bay
- B. Round notches on carrier handle (must fit over pegs in drive bay)
- C. Carrier handle

Exchanging SCSI hard drives

Drive cabling considerations

This section summarises device cabling requirements and constraints. The number of devices you can install depends on:

- ◆ The number supported by the bus
- ◆ The number of physical drive bays available
- ◆ The height of drives in the internal bays (1-inch or 1.6-inch high)
- ◆ The combination of SCSI and IDE devices

SCSI Requirements

One narrow and two wide SCSI cables are standard in the system.

All SCSI devices must be unterminated except the peripheral at the end of the SCSI cable. Hard drives usually provide an active termination, while CD-ROM drives do not. Because we recommend putting hard drives only in the internal bays, this means that you should route the SCSI cable so that the last device on the cable is a hard drive in the internal bay.

4 POWER SUPPLIES

Tools and supplies needed

- Phillips (cross-head) screwdriver (#1 and #2 bit).
- Pen or pencil.
- ◆ Equipment log: as you integrate new parts into the system, add information about them to your equipment log, at the back of the handbook. Record the model and serial number of the system, all installed options, and any other pertinent information specific to the system. You will need this information when running the SSU.

Warnings and cautions

These warnings and cautions apply whenever you remove the access cover of the system, or remove components from it. Only an authorised engineer or other suitably qualified technical person should attempt to integrate and configure the system.

- **System power on/off:** The on/off button on the front panel DOES NOT turn off the system AC power. To remove power from system, you must unplug the AC power cords from the wall outlet or the system.
- **Hazardous conditions, power supply:** Hazardous voltage, current, and energy levels are present inside the power supply. There are no user-serviceable parts inside it.
- **ESD and handling boards:** Always handle boards carefully. They can be extremely sensitive to ESD. Hold boards only by their edges. Do not remove boards from their protective wrapper until you are ready to put it straight into the system.
- **Cooling and airflow:** For proper cooling and airflow, always install the chassis access cover before turning on the system. Operating it without the cover in place may damage system components.
- **Avoid personal injury:** To avoid personal injury when unpacking the server, use a mechanical assist unit to lift it off the shipping pallet. The minimum server configuration weighs 38 kg; the maximum weighs 45 kg.
 - ◆ Do not attempt to lift or move the server by the handles on the power supplies.
 - ◆ Use a hand-truck or other mechanical assist unit to move the server from one location to another, or to raise it into position for rack mounting.

General specification

The chassis can be configured with one, two, or three 400-watt power supplies, each designed to minimise EMI and RFI. Each supply operates within the following voltage ranges and is rated as follows:

- 100 - 120 V AC at 50 - 60 Hz; 7.6 A maximum
- 200 - 240 V AC at 50 - 60 Hz; 3.8 A maximum

The DC output voltages of each power supply are as follows:

- +3.3 V at 36 A max
- +5 V at 24 A max (total combined output of +3.3 V and +5.5 V not to exceed 195 W)
- +12 V at 18.0 A with 19.0 A <10ms peak
- +24 V at 50mA
- -12 V at 0.5 A
- +5 V standby 1.5 A

Power is routed through the power cable to the 20-pin main connectors on the mainboard. Remote sensing signals are provided through the cable to the 14-pin auxiliary connector on the mainboard.

WARNING

There are no user serviceable parts within the power supply. Do not attempt to operate the unit on its own or open the case. Return any faulty or suspect power supplies to an authorised maintainer or your Mitsubishi supplier.

Power supply indicators

At the rear of the system, next to the power supply cable socket are two LEDs. They provide an indication of the general status of the individual power supply.

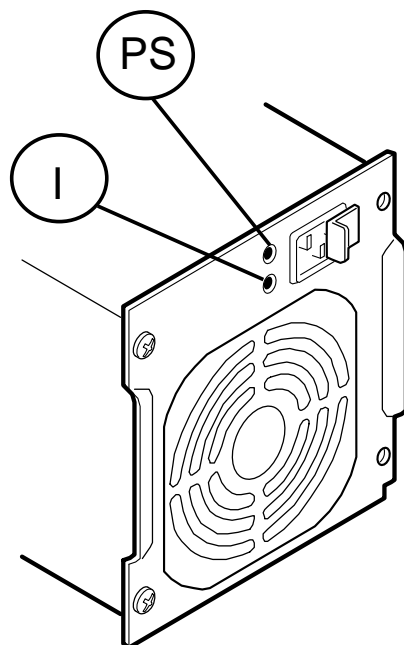

Status	Marking next to LED	
	PS	I
Power supply OK	ON	ON
Power supply FAILURE	OFF	OFF
Power supply in current limit	ON	OFF

In the case of power supply failure, follow the instructions given below to replace the faulty unit.

If the current limit is operating continuously, then the system may either have a fault elsewhere causing a power overload, or there may be a need for adding another power supply (If for example you have added extra boards, drives, processors or memory).

Replacing a power supply

1. Observe the precautions as given in *Safety & Regulatory Notices* at the front of this handbook.
2. Turn off and disconnect **all** peripheral devices connected to the system.
3. Turn off the system by using the power on/off switch on the front panel AND unplug all AC power cords.
4. Remove the four screws holding the power supply to the back of the chassis.

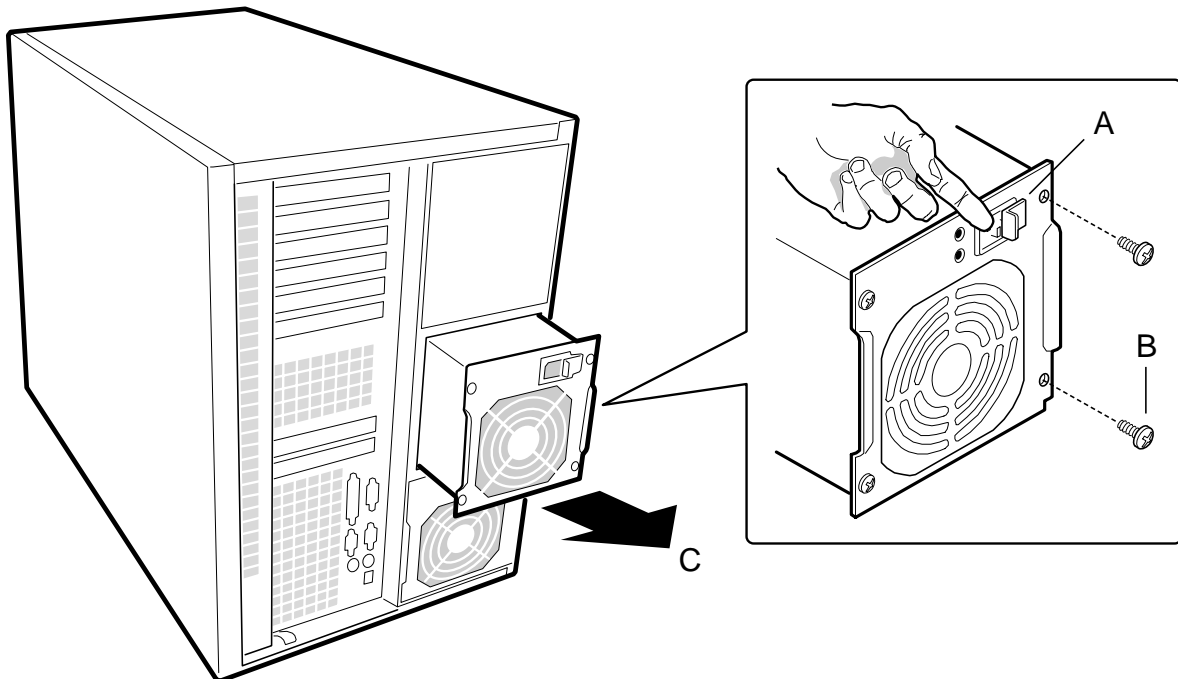

- A. AC connector cover
 B. Mounting screws
 C. Slide the power supply

5. Using the flared, vertical edges as handles, slide the supply straight back from its bay.

CAUTION

You might feel initial resistance in sliding the power supply from its bay. Do not tilt or twist the supply; this can damage components. Resistance is caused by the supply disengaging from its 40-pin connector. Use even, steady pressure to remove the supply.

Power supplies

Installing a power supply

1. Slide the power supply into its bay.
2. With even force on the flared, vertical edges, push toward the front of the system until the edges rest against the rear of the chassis and the supply engages its connector.
3. Install and tighten the four screws holding the supply to the back of the chassis.
4. Connect the AC power cable. You must slide the cover on the AC connector to access the connector itself, as shown in the illustration above (A).

5 MAINBOARD

Mainboard features

<i>Feature</i>	<i>Description</i>
Processor	<p>Installed: Up to four Pentium® II Xeon™ processors, packaged in single edge contact (S.E.C.) cartridges and installed in 330-pin Slot 2 processor connectors, operating at 1.8 V to 3.5 V. The mainboard voltage regulator is automatically programmed by the processor's VID pins to provide the required voltage.</p> <p>Includes connectors for six VRM 8.3-compliant plug-in voltage-regulator modules. Three modules per pair of processors, (a single processor needs two modules).</p>
Memory, dynamic random access (DRAM)	<p>Single plug-in module containing 64/72-bit four-way-interleaved pathway to main memory supporting EDO DRAM.</p> <ul style="list-style-type: none"> ◆ 128 MB to 4 GB of error correcting code (ECC) memory ◆ Four DIMMs per bank, all must be identical ◆ Minimum DIMM size 32Mb, recommended 60ns
Video memory (DRAM)	Installed: 2 MB of video memory.
PCI Segment A bus	<p>PCI-A—Three expansion connectors and four embedded devices:</p> <ul style="list-style-type: none"> ◆ Programmable interrupt device (PID) ◆ PCI/ISA/IDE Accelerator (PIIX4E) for PCI-to-ISA bridge, PCI IDE interface, and Universal Serial Bus (USB) controller ◆ PCI video controller (Cirrus Logic GD5480) ◆ PCI narrow SCSI controller (Symbios SYM53C810AE)
PCI Segment B bus	<p>PCI-B—Four expansion connectors (one physically shared with the ISA slot) and one embedded device:</p> <ul style="list-style-type: none"> ◆ Wide Ultra/Ultra II SCSI controller (Symbios SYM53C896)
ISA bus	One expansion slot for add-in boards (shared with a PCI-B slot). Embedded PC-compatible support (serial, parallel, mouse, keyboard, diskette).
Server Management	<p>Thermal/voltage monitoring and error handling.</p> <p>Front panel controls and indicators (LEDs).</p>
Graphics	Integrated onboard Cirrus Logic GD5480 super video graphics array (SVGA) controller.
SCSI	<p>Two embedded SCSI controllers:</p> <p>Symbios SYM53C810AE—narrow SCSI controller on PCI-A bus providing support for the legacy 8-bit SCSI devices in the 5.25-inch drive bays.</p> <p>Symbios SYM53C896—dual-channel wide LVD/SE (Ultra2/Ultra) SCSI controller on PCI-B bus driving one SCSI backplane in the system and providing support for external expansion.</p>
System I/O	<p>PS/2-compatible keyboard and mouse ports, 6-pin DIN.</p> <p>Advanced parallel port, supporting Enhanced Parallel Port (EPP) levels 1.7 and 1.9, ECP, compatible 25-pin.</p> <p>VGA video port, 15-pin.</p> <p>Two serial ports, 9-pin (serial port A is the top connector).</p>

Connector and component locations

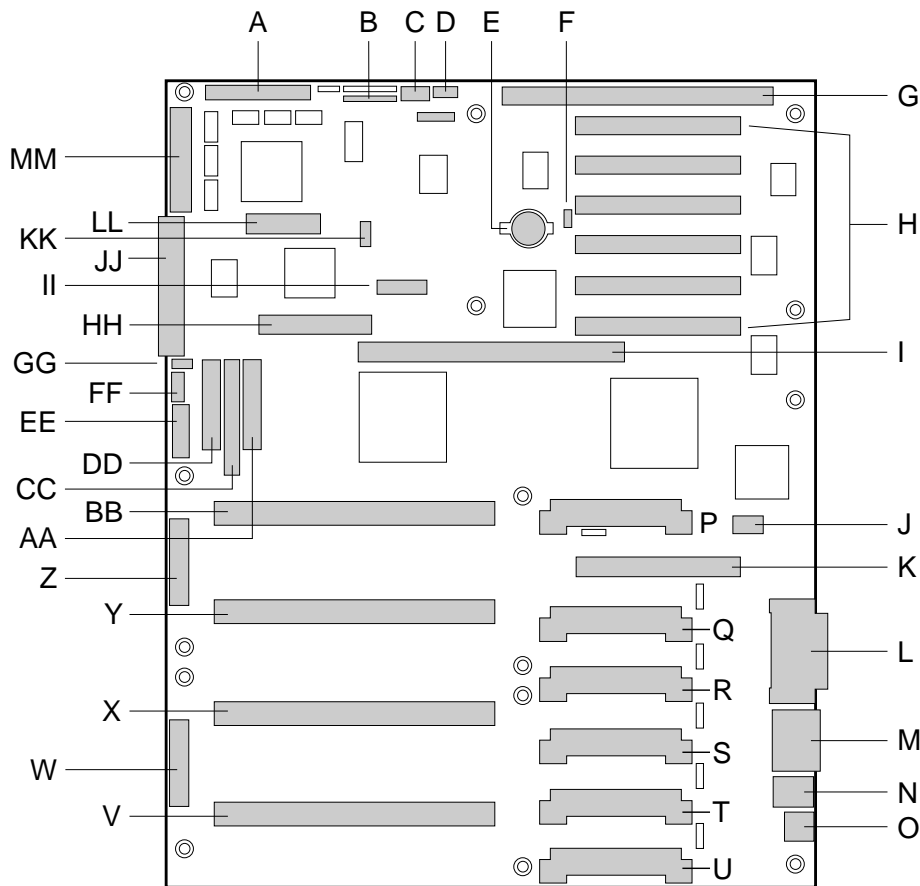

- A. Wide SCSI B connector (J9J1)
- B. System jumpers (J6J1)
- C. Hard drive input LED connector (J6J2)
- D. System speaker connector (J6J2)
- E. Lithium battery (B4H1)
- F. Wake-on-LAN technology connector (J4H1)
- G. ISA slot (J1J1)
- H. PCI slots B4 (closest to ISA), B3, B2, B1, A3, and A2 (farthest from ISA)
- I. Memory module connector (J3G1)
- J. ICMB connector (J1E1)
- K. PCI slot A1 (J2D1)
- L. Video and parallel port connectors (J1C1)
- M. Serial port connector (J1B2)
- N. Keyboard and mouse connectors (J1B1)
- O. USB external connector (J1A1)
- P. VRM connector for processor 4 (J4E1)
- Q. VRM connector for processors 4 and 3 (J4C2)
- R. VRM connector for processor 3 (J4C1)
- S. VRM connector for processor 2 (J4B1)
- T. VRM connector for processors 2 and 1 (J4A2)
- U. VRM connector for processor 1 (J4A1)
- V. Processor 1 Slot 2 connector (J9A1)
- W. Main power connector, primary (J9B1)
- X. Processor 2 Slot 2 connector (J9B2)
- Y. Processor 3 Slot 2 connector (J9D1)
- Z. Main power connector, secondary (J9D2)
- AA. Front panel connector (J8E1)
- BB. Processor 4 Slot 2 connector (J9E1)
- CC. IDE connector (J9E2)
- DD. Diskette drive connector (J9E3)
- EE. Auxiliary power connector (J9E4)
- FF. USB internal header (JC9F14)
- GG. SMBus connector (J9F2)
- HH. F16 expansion connector (J7G1)
- II. ITP connector (J6G1)
- JJ. Narrow SCSI connector (J9H1)
- KK. External IPMB connector (J7H1)
- LL. SMM connector (J8H1)
- MM. Wide SCSI A connector (J9H2)

Jumpers

One 11-pin single inline header provides three 3-pin jumper blocks that control various configuration options. Items in **bold** in show default placement for each configurable option.

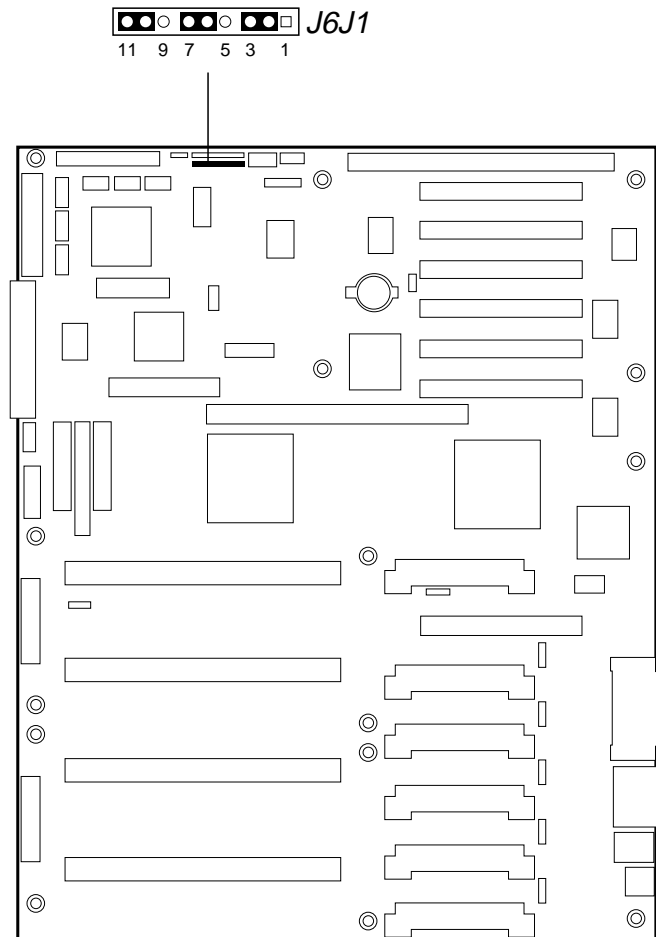

Function	Pins (default in bold)	What it does at system reset
CMOS clear	1-2, BMC Control	Preserves the contents of NVRAM.
	2-3, Force Erase	Replaces the contents of NVRAM with the manufacturing default settings.
Password clear	5-6, Protect	Maintains the current system password.
	6-7, Erase	Clears the password.
Recovery Boot	9-10, Normal	System attempts to boot using the BIOS stored in flash memory.
	10-11, Recovery	BIOS attempts a recovery boot, loading BIOS code from a diskette into the flash device. This is typically used when the BIOS code has been corrupted.

Before carrying out any work inside the system

Tools and supplies needed

- ◆ Phillips (cross-head) screwdriver (#1 and #2 bit).
- ◆ Small flat-bladed screwdriver.
- ◆ Jumper removal tool or needle-nosed pliers.
- ◆ Antistatic wrist strap and conductive foam pad (recommended).
- ◆ Pen or pencil.
- ◇ Equipment log: as you integrate new parts into the system, add information about them to your equipment log, at the back of the handbook. Record the model and serial number of the system, all installed options, and any other pertinent information specific to the system. You will need this information when running the SSU.

Safety: before you remove the access cover

Before removing the access cover at any time to work inside the system, observe these safety guidelines.

1. Turn off and disconnect **all** peripheral devices connected to the system.
2. Turn off the system by using the push-button on/off power switch on the front of the system.
3. Unplug the AC power cords from the system or wall outlet.
4. Use full antistatic precautions as given in the *Safety & Regulatory Notices* at the front of this handbook.

Warnings and cautions

These warnings and cautions apply whenever you remove the access cover of the system, or remove any components from it. Only an authorised engineer or other suitably qualified technical person should attempt to integrate and configure the system.

- ◆ **System power on/off:** The on/off button on the front panel DOES NOT turn off the system AC power. To remove power from system, you must unplug the AC power cords from the wall outlet or the system.
- ◆ **Hazardous conditions, power supply:** Hazardous voltage, current, and energy levels are present inside the power supply. There are no user-serviceable parts inside it.
- ◆ **ESD and handling boards:** Always handle boards carefully. They can be extremely sensitive to ESD. Hold boards only by their edges. Do not remove boards from their protective wrapper until you are ready to put it straight into the system.
- ◆ **Cooling and airflow:** For proper cooling and airflow, always install the chassis access cover before turning on the system. Operating it without the cover in place may damage system components.
- ◆ **Avoid personal injury:** To avoid personal injury when unpacking the server, use a mechanical assist unit to lift it off the shipping pallet. The minimum server configuration weighs 38 kg; the maximum weighs 45 kg.
 - ◇ Do not attempt to lift or move the server by the handles on the power supplies.
 - ◇ Use a hand-truck or other mechanical assist unit to move the server from one location to another, or to raise it into position for rack mounting.

General procedure for all jumper settings

The short general procedure for changing a configuration setting is the same for most of the jumper functions, so we will describe it first.

1. Read through the instructions on page 4 of this chapter.
2. Remove the access cover as detailed in Chapter 2. You do not need to remove the baseboard from the chassis, and you probably do not need to remove any add-in boards.
3. Locate the configuration jumpers at the edge of the baseboard toward the front of the system.
4. Move jumper to pins specified for the desired setting.
5. Reinstall the access cover using the original screws, connect the power cords, and turn on the system for the change to take effect.
6. You may need to repeat these steps to move the jumper back to its original setting, depending on the jumper function.

CMOS clear jumper

The jumper at pins 1, 2, and 3 controls whether settings stored in CMOS nonvolatile memory (NVRAM) are retained during a system reset.

Procedure to restore the system's CMOS and RTC to default values:

1. Move the CMOS jumper from pins 1 and 2 to pins 2 and 3 (the Clear CMOS memory position).
2. Reinstall the access cover for your safety (using the original screws), and connect the power cords to the system.
3. Turn the system on. Wait for POST to complete and for the messages 'NVRAM cleared by jumper' and 'Press F2 to enter Setup' to appear. This automatically reprograms CMOS and RTC to their default settings, except for the password.
4. Enter Setup and make any changes necessary (for example, changing the boot device). Press F10 to save the new Setup configuration and exit Setup.
5. Turn off the system, and disconnect all AC power cords from the system.
6. Again remove the access cover.
7. Move the jumper from pins 2 and 3 back to pins 1 and 2 (the Protect CMOS memory position).
8. Reinstall the access cover using the original screws, and connect the power cords to the system.
9. Run BIOS Setup or the SSU to verify the correct settings. See the 'Configuration' chapter

Password clear jumper

The jumper at pins 5, 6, and 7 controls whether a stored password is retained or cleared during a system reset.

Procedure to clear the current password and then enter a new one:

1. Move the Password jumper from pins 5 and 6 to pins 6 and 7.
2. Reinstall the access cover for your safety (using the original screws), and connect the power cords to the system.
3. Turn the system on, and wait for POST to complete. This automatically clears the password.
4. Turn off the system, and disconnect all AC power cords.
5. Again remove the access cover.
6. Move the jumper from pins 6 and 7 back to pins 5 and 6.
7. Reinstall the access cover using the original screws and connect the power cords to the system.
8. Run the SSU to specify a new password. See the 'Configuration' chapter.

Recovery boot jumper

The jumper at pins 9, 10, and 11 controls whether the system attempts to boot using the BIOS programmed in flash memory.

Procedure to disable recovery booting:

1. Move the recovery boot jumper from pins 9 and 10 to pins 10 and 11.
2. Reinstall the access cover for your safety (using the original screws), then connect the power cords to the system.
3. Turn the system on, and insert the Flash Memory Update Utility diskette in drive A. After the system boots, the speaker emits a single beep and the recovery process starts. This takes about three minutes. When the recovery process completes, the speaker emits two beeps.

While in the recovery mode, there is no screen display on the monitor. The keyboard is disabled as the system automatically recovers the BIOS. The following beep codes describe the recovery status.

Beep Code	Message
2	Successful completion, no errors.
4	The system could not boot from the diskette. The diskette may not be bootable.
Continuous series of low beeps	The wrong BIOS recovery files are being used and/or the flash memory jumper is in the wrong position.

4. Turn the system off, disconnect all AC power cords from the system, and remove the access cover.
5. Move the jumper from pins 10 and 11 back to pins 9 and 10 to enable the normal boot mode.
6. Replace the access cover, remove the diskette from drive A, and connect the power cords to the system.
7. After running the special recovery mode, run the SSU to specify a new password. See the 'Configuration' chapter.

Processor

The FT5000 can be fitted with up to four Pentium II Xeon processors. They must be fitted from the bottom socket upwards as shown in the illustration earlier in this section. The appropriate voltage regulators must also be fitted, as detailed on page 10 of this chapter.

Each Pentium II Xeon processor is packaged in a single edge contact (S.E.C.) cartridge. The cartridge includes the processor core with an integrated 16 KB primary (L1) cache; the secondary (L2) cache; a thermal plate; and a back cover. Each S.E.C. cartridge connects to the baseboard through a 330-pin Slot 2 edge connector. The cartridge is secured by a retention module attached to the baseboard. Depending on configuration, your system has one to four processors.

The processor external interface is MP-ready and operates at 100 MHz. The processor contains a local APIC unit for interrupt handling in multiprocessor (MP) and uniprocessor (UP) environments.

The L2 cache is located on the substrate of the S.E.C. cartridge. The cache includes burst pipelined synchronous static RAM (BSRAM) and is available in 512 KB, 1 MB, and 2 MB configurations, with ECC that operates at the full core clock rate.

CAUTION

Processor must be appropriate: You might damage the system if you install a processor that is inappropriate for your system. Make sure your system can handle a newer, faster processor (thermal and power considerations). For exact information about processor interchangeability, contact your Mitsubishi Electric PC dealership.

Removing a processor

1. Read through the instructions on page 4 of this chapter and any additional cautions given here.
2. Remove the access cover as detailed in Chapter 2 and the rear foam cover over the electronics bay.
3. As you work, place processors on a grounded, static-free surface or conductive foam pad.
4. With your right thumb on the face of the retention module bracket (A) in illustration below, wrap your right index finger around the tab (B) protruding from the right edge of the bracket.
5. Use your index finger to slightly pull the tab outward and to the left. You should not try to pull the entire bracket; rather, the back of the tab has a latch (C) that releases when the TAB is pulled slightly.
6. When you have released the right edge of the bracket, rotate it 90° to the left until it is perpendicular to the front of the retention module. The left edge of the bracket has an open hinge that can release from the module when you rotate the bracket to the left.

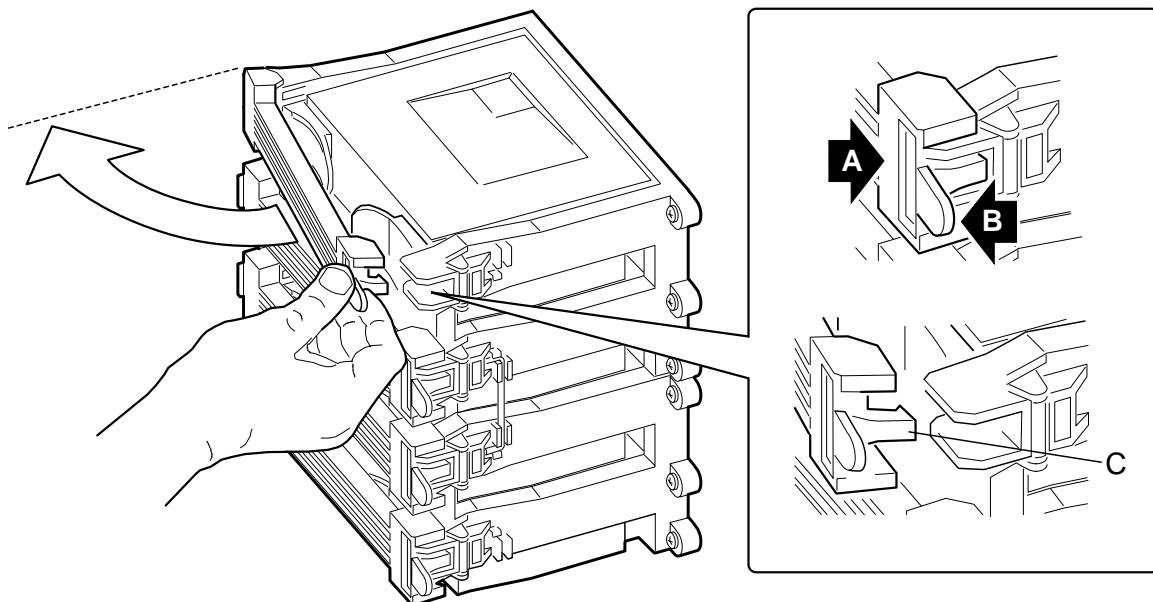

- A. Retention module bracket
- B. Tab of bracket
- C. Latch

7. Disengage the open hinge by moving (not rotating) the entire bracket to the right. Remove the bracket and set it aside.
8. Pull the two tabs attached to the S.E.C. cartridge (visible after you remove the bracket (C) in the illustration below, straight away from the baseboard. As you do, the cartridge disengages from its connector on the baseboard.
9. Slide the S.E.C. cartridge straight away from the baseboard, out of the retention module. Put it on a piece of conductive foam and store it in an antistatic package.

Mainboard

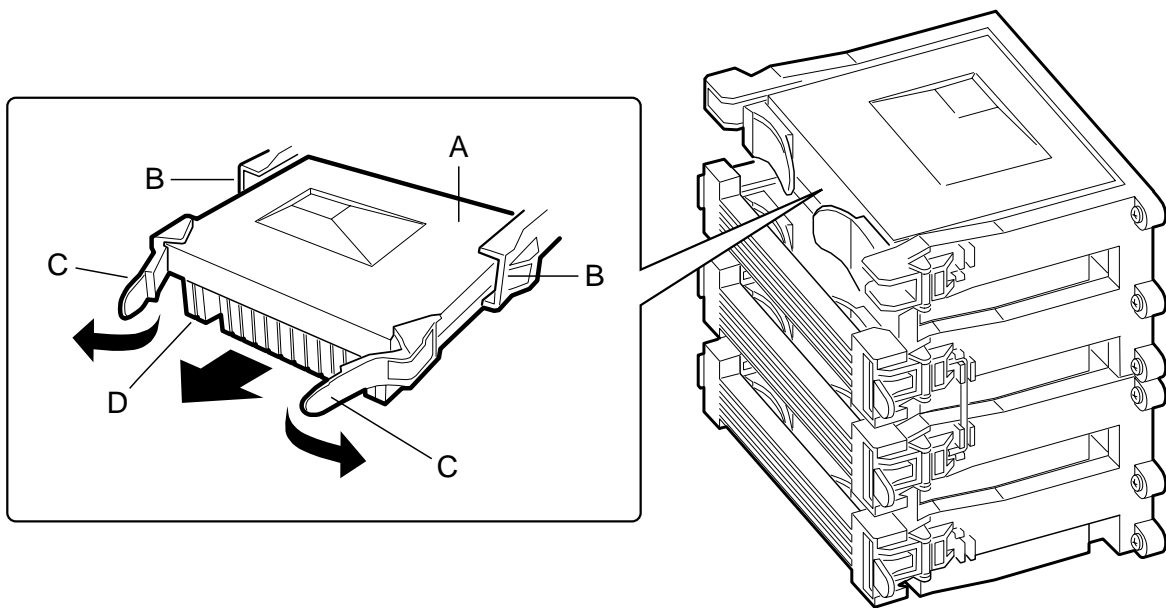

- A. S.E.C. cartridge
- B. Retention module guide rails
- C. Tabs on S.E.C. cartridge
- D. Processor heat sink

Installing a processor

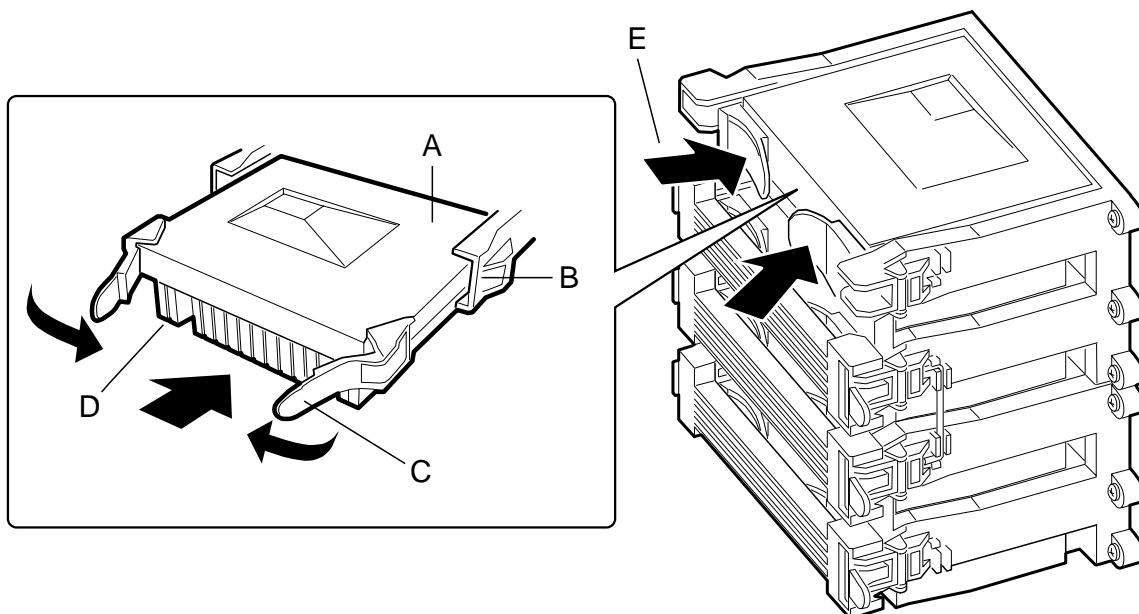

- A. S.E.C. cartridge
- B. Retention module guide rails
- C. Tabs on S.E.C. cartridge
- D. Processor heat sink (must face away from center of baseboard)
- E. Push tabs on S.E.C. cartridge inward to seat processor

NOTE

If your system has less than four processors and you are ADDING one, then you must remove the termination board in the empty Slot 2 connector. The procedure for removing a termination board is the same as for removing a processor

If you plan to reduce the number of processors in your system, then you must replace a processor with a termination board. The procedure for installing a termination board is the same for installing a processor.

1. Read through the instructions on page 4 of this chapter and any additional cautions given here.
2. Remove the new processor from its antistatic package and place it on a grounded, static-free surface or conductive foam pad.
3. Orient the S.E.C. cartridge so that the heat sink faces away from the center of the baseboard.
4. If you are installing a termination board, orient it so that the side with the white bar-code label faces away from the center of the baseboard.
5. With the tabs at the top of the S.E.C. cartridge completely open (pulled outward, away from the center of the cartridge (C), slide the cartridge into the guide rails of the retention module (B). When done properly, the triangular ends of the tabs (with two round pegs on each) fit into the entrance to the guide rails.
6. When the cartridge meets resistance, push the two tabs toward each other (E) until the processor is fully seated.
7. Reattach the retention module bracket:
 - ◇ With the bracket in an open position (perpendicular to the front of the retention module), slide the open hinge at the left of the bracket into its receptacle at the left of the retention module.
 - ◇ Rotate the bracket to the right until it reaches the retention module. With your right thumb on the face of the bracket and your right index finger around the tab at the right of the bracket, slightly pull the tab outward and to the left to open the latch at the back of the tab.
 - ◇ As you open the latch on the back of the tab, slide the right edge of the bracket onto the retention module and release the tab. If done correctly, the bracket will be securely latched.
8. Fit the required power regulation modules, (see next page).
9. Reinstall the foam cover.
10. Reinstall the access cover using the original screws.

WARNING

When adding extra processors, the required power regulation modules must be fitted. Do not attempt to run the system without the correct number of power modules or you risk serious and permanent damage to the existing modules, the processors or the system mainboard.

Power regulator modules

The mainboard has sockets for up to six power regulator modules. They must be VRM 8.3-compliant, each *pair* of processors needing *three* modules.

This means that if you are only fitting *one* extra processor you will need to fit *two* modules.

The modules should be purchased at the same time as any processor. Contact your Mitsubishi Electric PC dealership.

1. Read through the instructions on page 4 of this chapter and any additional cautions given here.
2. Remove the new power modules from their antistatic package and place them on a grounded, static-free surface or conductive foam pad.
3. New modules should be fitted from the bottom socket upwards, into the next available empty socket (see table at foot of page).
4. Press the module firmly into the socket and make sure the retaining clips click into place.

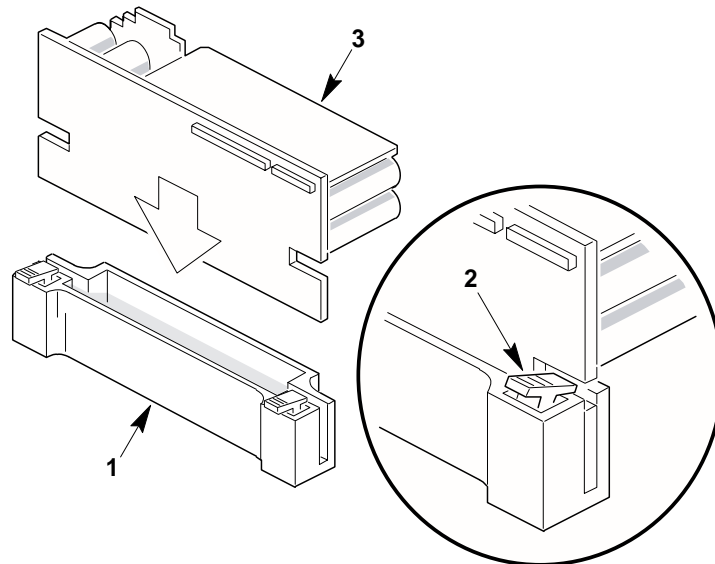

- 1 VRM socket
- 2 Module retention clip
- 3 Voltage Regulator Module (VRM)

5. Reinstall the foam cover.
6. Reinstall the access cover using the original screws.

To remove a module at any time just press the retaining clips down and pull the module from its socket. If you are not removing processors, a replacement module must be fitted.

In conjunction with the table below, refer to the illustration on page 2 of this chapter for correct component fitting.

Number of processors fitted	VRMs required
1 (socket marked 'V')	2 (sockets marked 'U' and 'T')
2 (sockets marked 'V' and 'W')	3 (sockets marked 'U', 'T' and 'S')
3 (sockets marked 'V', 'W' and 'X')	5 (sockets marked 'U', 'T', 'S', 'R' and 'Q')
4 (sockets marked 'V', 'W', 'X' and 'BB')	6 (sockets marked 'U', 'T', 'S', 'R', 'Q' and 'P')

Memory

The memory module contains slots for 16 DIMMs and is attached to the mainboard through a 242-pin connector. Memory amounts from 128 MB to 4 GB of DIMM are supported, with a 64/72-bit four-way-interleaved pathway to main memory, which is also located on the module.

The 16 slots are divided into four banks of four slots each, labelled A to D. These banks support 4:1 interleaving. The memory controller supports EDO DRAMs. The four DIMMs in any bank must be identical and preferably should be 60ns, each individual DIMM must be at least 32 MB.

The ECC used for the memory module is capable of correcting single-bit errors (SBEs) and detecting 100 percent of double-bit errors over one code word. Nibble error detection is also provided.

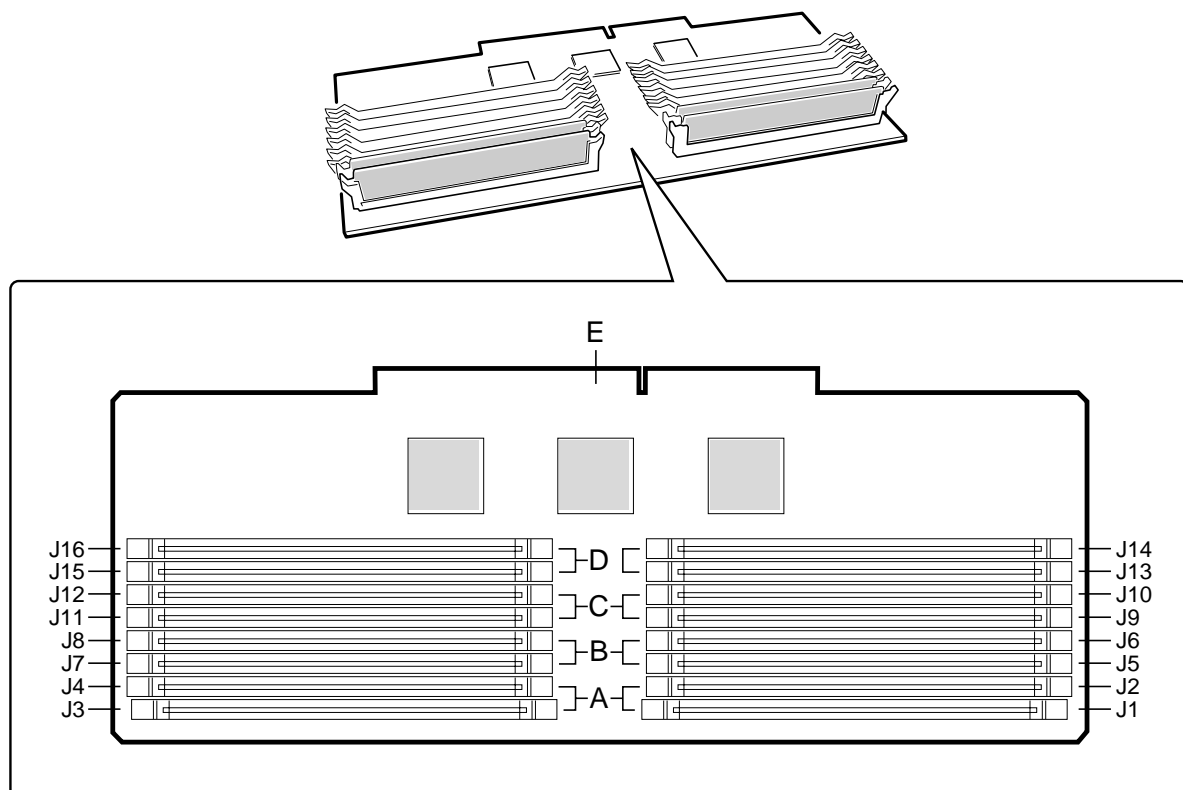

- A. Memory bank A (install first)
- B. Memory bank B (install second)
- C. Memory bank C (install third)
- D. Memory bank D (install last)
- E. Memory module connector

System memory begins at address 0 and is continuous (flat addressing) up to the maximum amount of DRAM installed (exception: system memory is noncontiguous in the ranges defined as memory holes using configuration registers). The system supports both base (conventional) and extended memory.

- ◆ Base memory is located at addresses 00000h to 9FFFFh (the first 1 MB).
- ◆ Extended memory begins at address 0100000h (1 MB) and extends to FFFFFFFFh (4 GB), which is the limit of supported addressable memory. The top of physical memory is a maximum of 4 GB (to FFFFFFFFh).

Mainboard

BIOS automatically detects, sizes, and initialises the memory array, depending on the type, size, and speed of the installed DIMMs, and reports memory size and allocation to the system via configuration registers.

In a 4 GB configuration, a small part of memory (typically 32 MB) is not remapped above 4 GB. If your OS does not support more than 4 GB of physical memory, this small part of the memory is effectively lost.

NOTE

DIMM sizes and compatibility: only use DIMMs that have been tested for compatibility with the memory board. Contact your Mitsubishi Electric dealership for a list of approved DIMMs. The table below lists some sample size combinations.

Sample DIMM component combinations

Bank A (slots J1 - 4)	Bank B (slots J5 - 8)	Bank C (slots J9 - 12)	Bank D (slots J13 - 16)	Total Memory
4x32				128 MB
4x32	4x32			256 MB
4x32	4x32	4x32	4x32	512 MB
4x64	4x64	4x64	4x64	1024 MB
4x128	4x128	4x128	4x128	2048 MB

Removing the memory module

NOTE

Make sure you run the SSU to configure ECC memory. Failure to do so might degrade the performance of the server.

1. Read through the instructions on page 4 of this chapter.
2. Remove the access cover, for detailed instructions see Chapter 2.
3. Remove the rear foam cover over the electronics bay. It might be easier to do this if you also remove the front foam cover over the front subchassis.
4. Remove the memory module from the baseboard:
 - ◇ Pull the module toward you slightly to disengage it from the baseboard connector.
 - ◇ Slide the module straight away from the baseboard until it clears the guide rails.
 - ◇ Place the module component-side up on a nonconductive, static-free surface.

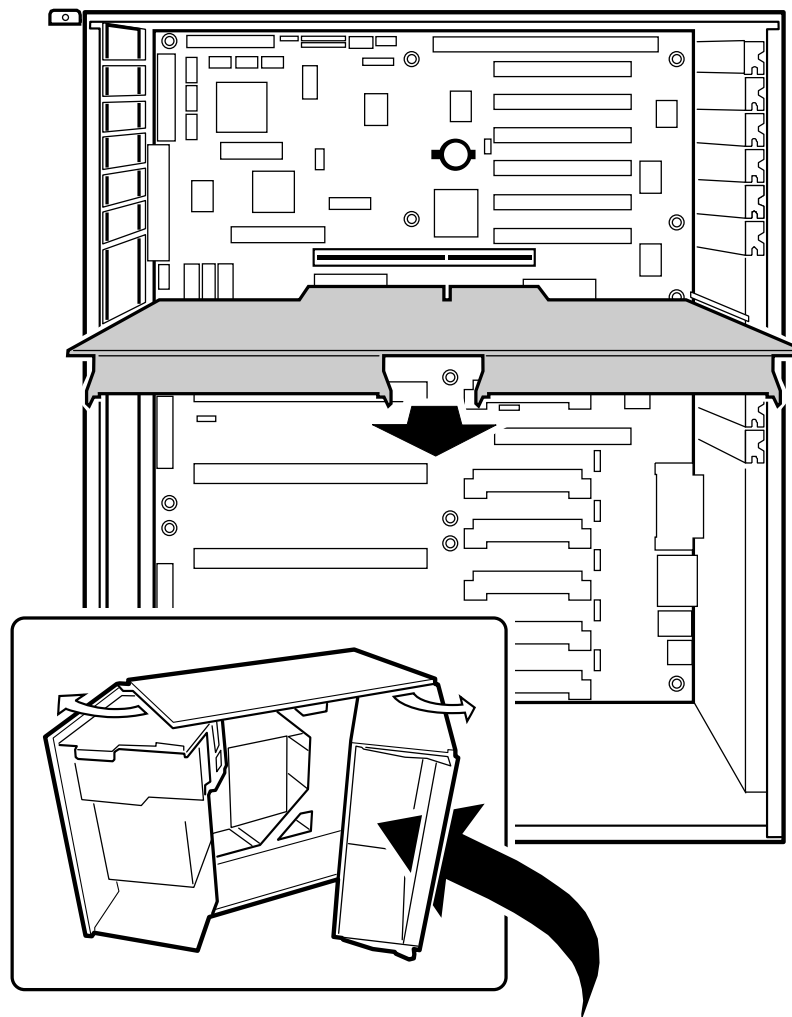

Installing the memory module

1. Read through the instructions on page 4 of this chapter.
2. Holding the memory module by its edges, align the module so its edge engages in the guide rail at the back of the electronics bay.

CAUTION

The memory module is held in place by the 242-pin connector on the baseboard, the guide rail at the back of the electronics bay, and a plastic guide at the front of the electronics bay. You must support the module until it is fully seated in the connector.

3. Push the memory module toward the baseboard until it fully engages its connector.

Removing DIMMs

CAUTION

Use extreme care when removing a DIMM. Too much pressure can damage the socket slot. Apply only enough pressure on the plastic ejector levers to release the DIMM.

1. Read through the instructions on page 4 of this chapter.
2. Remove the memory module as detailed above and place it component-side up on a nonconductive, static-free surface.
3. Gently push the plastic ejector levers out and down to eject a DIMM from its socket.
4. Hold the DIMM only by its edges, being careful not to touch its components or gold edge connectors. Carefully lift it away from the socket and store it in an antistatic package.
5. Repeat to remove other DIMMs as necessary.
6. If you are REPLACING DIMMs, proceed to 'Installing DIMMs'.
7. If you are simply REMOVING DIMMs, continue the procedure with the following steps.
8. Reinstall the memory module.
9. Reinstall the foam cover(s).
10. Connect all external cables and power cords to the system.
11. Reinstall the access cover using the original screws.
12. Turn on the monitor and then the system.
13. Run the SSU/BIOS Setup to configure the system and to properly set up advanced memory attributes as required.

Installing DIMMs

CAUTION

Use extreme care when installing a DIMM. Applying too much pressure can damage the socket. DIMMs are keyed and can be inserted in only one way.

NOTE

DIMM slots on the memory module must be installed only in certain configurations. See 'Memory' on page 10 of this chapter for more information.

1. Holding the DIMM only by its edges, remove it from its antistatic package.
2. Orient the DIMM so that the two notches in the bottom edge of the DIMM align with the keyed socket on the memory module.
3. Insert the bottom edge of the DIMM into the socket, then press down firmly on the DIMM until it seats correctly.
4. Gently push the plastic ejector levers on the socket ends to the upright position.
5. Repeat the steps to install each DIMM.

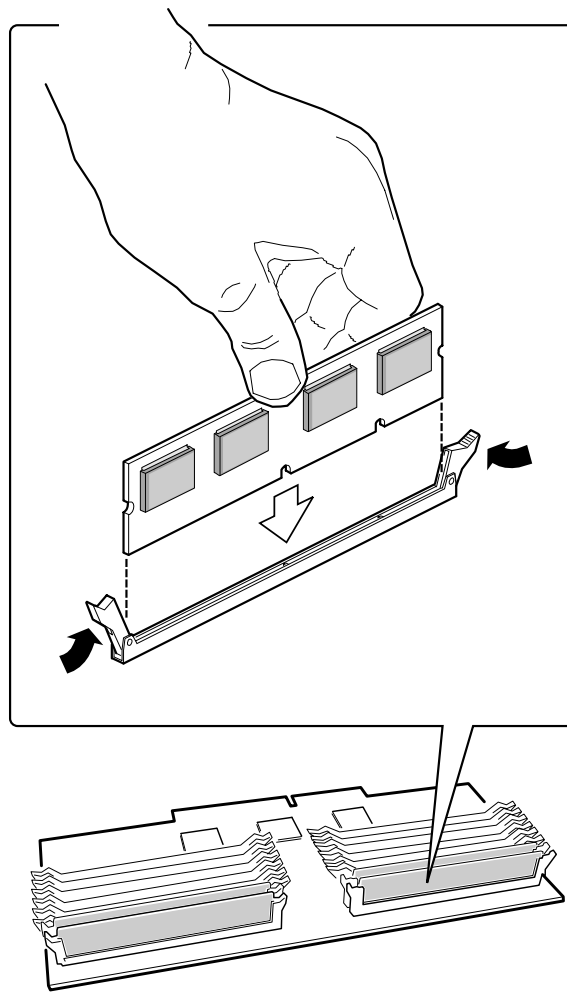

6. Reinstall the memory module.
7. Reinstall the foam cover(s).
8. Reinstall the access cover using the original screws.
9. Connect all external cables and the power cords to the system.
10. Turn on the monitor and then the system.
11. Run the SSU to configure the system and to properly attribute ECC memory.

Replacing the backup battery

The lithium battery on the baseboard powers the real-time clock (RTC) for three to four years in the absence of power. When the battery weakens, it loses voltage and the system settings stored in CMOS RAM in the RTC (e.g. the date and time) may be wrong.

CAUTION

Replace only with the same or equivalent type recommended by your Mitsubishi Electric supplier. Discard used batteries strictly according to the battery manufacturer's instructions.

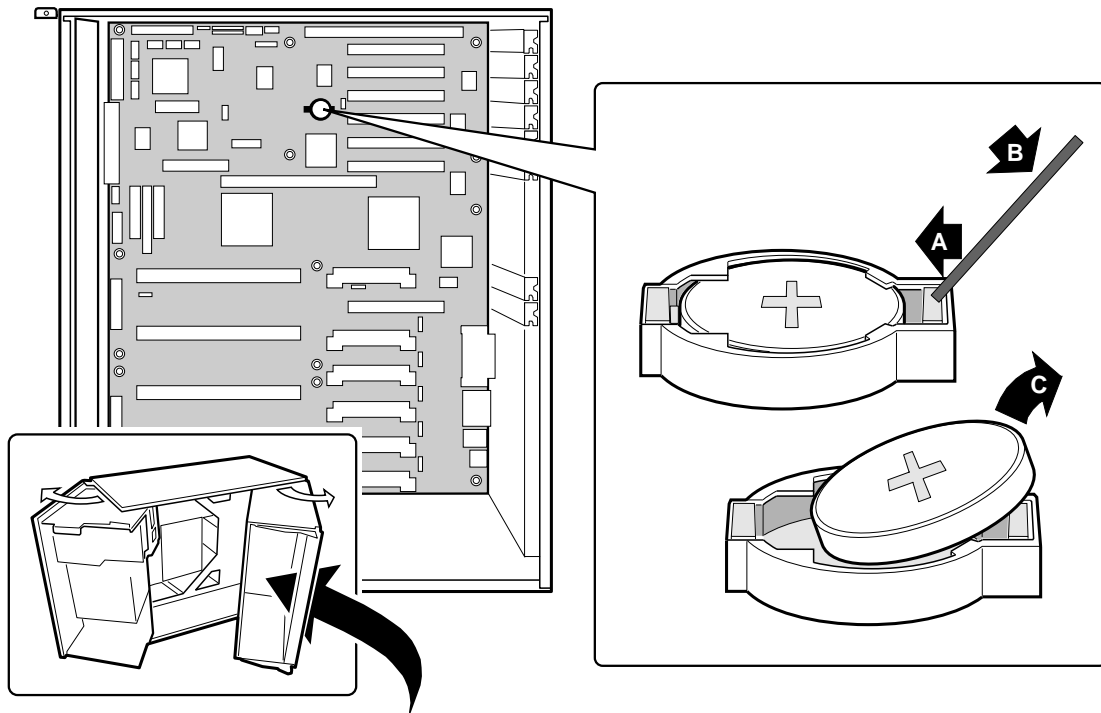

1. Read through the instructions on page 4 of this chapter.
2. Remove the access cover, for detailed instructions see Chapter 2.
3. Insert the tip of a small non-metallic under the plastic tab on the snap-on plastic retainer.

WARNING

You must not use a metal or other conductive implement to remove the battery. If a short-circuit is accidentally made between the battery's positive and negative terminals, the battery may explode.

4. Gently push down on the tool to lift the battery.
5. Remove the battery from its socket.
6. Remove the new lithium battery from its package and, being careful to observe the correct polarity, insert it in the battery socket.
7. Reinstall the plastic retainer on the lithium battery socket.
8. Reinstall the access cover using the original screws.
9. Run the SSU to restore the configuration settings to the RTC.

Add-in board slots

The baseboard has one ISA slot that is full-length if the wide SCSI-B slot is not used (and half-length if the wide SCSI-B slot *is* used); the ISA slot supports slave-only boards and is shared with PCI-B slot 4. The ISA has three embedded devices: the Super I/O chip, Baseboard Management Controller (BMC), and flash memory for system BIOS.

ISA features:

- ◆ Bus speed up to 8.33 MHz
- ◆ 16-bit memory addressing
- ◆ Type A transfers at 5.33 MB/sec
- ◆ Type B transfers at 8 MB/sec
- ◆ 8- or 16-bit data transfers
- ◆ Plug and Play ready

The baseboard has two 32-bit PCI bus segments: PCI-A and PCI-B. These provide seven slots for PCI add-in boards: three on PCI-A and four on PCI-B. PCI-B4 is shared with the ISA slot. PCI-A1 supports half-length boards only. The other slots support full-length boards.

PCI features:

- ◆ 33 MHz bus speed
- ◆ 32-bit memory addressing
- ◆ 5 V signaling environment
- ◆ Burst transfers of up to 133 MB/sec
- ◆ 8-, 16-, or 32-bit data transfers
- ◆ Plug and Play ready
- ◆ Parity enabled

Video

The onboard, integrated Cirrus Logic CL-GD5480 64-bit VGA chip contains an SVGA controller that is fully compatible with these video standards: CGA, EGA, Hercules Graphics, MDA, and VGA. The standard system configuration comes with 2 MB of 10ns onboard video memory. The video controller supports pixel resolutions of up to 1600 x 1200 and up to 16.7 M colors.

The SVGA controller supports analog VGA monitors (single and multiple frequency, interlaced and noninterlaced) with a maximum vertical retrace noninterlaced frequency of 100 Hz.

You can not add video memory to this system. Depending on the environment, the controller displays up to 16.7 M colours in some video resolutions. It also provides hardware-accelerated bit block transfers (BITBLT) of data.

SCSI controller

The baseboard includes two SCSI controllers. A narrow SCSI controller (SYM53C810AE) is on the PCI-A bus, and a dual-channel wide LVD/SE (Ultra2/Ultra) SCSI controller (SYM53C896) is on the PCI-B bus. The narrow provides support for the legacy 8-bit SCSI devices in the 5.25-inch drive bays. The wide drives one SCSI backplane and provides support for external expansion.

Internally, each wide channel is identical, capable of operations using either 8- or 16-bit SCSI providing 10 MB/sec (Fast-10) or 20 MB/sec (Fast-20) throughput, or 20 MB/sec (Ultra) or 40 MB/sec (Ultra-wide).

The SYM53C810AE (narrow) contains a high-performance SCSI core capable of Fast 8-bit SCSI transfers in single-ended mode. It provides programmable active negation, PCI zero wait-state bursts of faster than 110 MB/sec at 33 MHz, and SCSI transfer rates from 5 to 10 MB/sec. The narrow SCSI comes in a 100-pin rectangular plastic quad flat pack (PQFP) and provides an "AND tree" structure for testing component connectivity.

The Sym53C896 (wide) contains a high-performance SCSI bus interface. It supports SE mode with 8-bit (10 or 20 MB/sec) or 16-bit (20 or 40 MB/sec) transfers and LVD mode with 8-bit (40 MB/sec) or 16-bit (80 MB/sec) transfers in a 329-pin ball grid array (BGA) package.

Each controller has its own set of PCI configuration registers and SCSI I/O registers. As a PCI 2.1 bus master, the SYM53C896 supports burst data transfers on PCI up to the maximum rate of 132 MB/sec using on-chip buffers.

In the internal bay, the system supports up to six one-inch SCSI hard disk drives, plus, in the 5.25-inch removable media bays, two SCSI devices (the controller itself supports more devices, but the chassis can contain a maximum of eight). A wide SCSI cable provides two connectors for Ultra SCSI devices. However, SCSI devices do not need to operate at the ultra transfer rate. Each SCSI channel runs at the speed of the slowest device on the channel.

No logic, termination, or resistor loads are required to connect devices to the SCSI controller other than termination in the device at the end of the cable. The SCSI bus is terminated on the baseboard with active terminators that can be disabled.

IDE controller

IDE is a 16-bit interface for intelligent disk drives with AT disk controller electronics onboard. The PCI/ISA/IDE Accelerator, called PIIX4E, is a multifunction device on the baseboard that acts as a PCI-based Fast IDE controller.

The device controls:

- ◆ PIO and IDE DMA/bus master operations
- ◆ Mode 4 timings
- ◆ Transfer rates up to 22 MB/sec
- ◆ Buffering for PCI/IDE burst transfers
- ◆ Master/slave IDE mode
- ◆ Up to two drives for one IDE channel

6 I/O ADDRESSES, INTERRUPTS ETC.

System I/O addresses

The following table shows the location in I/O space of all directly I/O-accessible registers.

<i>Address</i>	<i>Resource</i>	<i>Device</i>	<i>Notes</i>
0000h - 000Fh	DMA Controller 1	PIIX4E	
0010h - 001Fh	DMA Controller 1	PIIX4E	Aliased from 0000h - 000Fh
0020h - 0021h	Interrupt Controller 1	PIIX4E	
0022h - 0023h			
0024h - 0025h	Interrupt Controller 1	PIIX4E	Aliased from 0020h - 0021h
0026h - 0027h			
0028h - 0029h	Interrupt Controller 1	PIIX4E	Aliased from 0020h - 0021h
002Ah - 002Bh			
002Ch - 002Dh	Interrupt Controller 1	PIIX4E	Aliased from 0020h - 0021h
002Eh - 002Fh	Super I/O Index and Data Ports		
0030h - 0031h	Interrupt Controller 1	PIIX4E	Aliased from 0020h - 0021h
0032h - 0033h			
0034h - 0035h	Interrupt Controller 1	PIIX4E	Aliased from 0020h - 0021h
0036h - 0037h			
0038h - 0039h	Interrupt Controller 1	PIIX4E	Aliased from 0020h - 0021h
003Ah - 003Bh			
003Ch - 003Dh	Interrupt Controller 1	PIIX4E	Aliased from 0020h - 0021h
003Eh - 003Fh			
0040h - 0043h	Programmable Timers	PIIX4E	
0044h - 004Fh			
0050h - 0053h	Programmable Timers	PIIX4E	Aliased from 0040h - 0043h
0054h - 005Fh			
0060h, 0064h	Keyboard Controller		Keyboard chip select from 87307
0061h	NMI Status & Control Register	PIIX4E	
0063h	NMI Status & Control Register	PIIX4E	Aliased
0065h	NMI Status & Control Register	PIIX4E	Aliased
0067h	NMI Status & Control Register	PIIX4E	Aliased
0070h	NMI Mask (bit 7) & RTC Address (bits 6::0)	PIIX4E	
0072h	NMI Mask (bit 7) & RTC Address (bits 6::0)	PIIX4E	Aliased from 0070h
0074h	NMI Mask (bit 7) & RTC Address (bits 6::0)	PIIX4E	Aliased from 0070h
0076h	NMI Mask (bit 7) & RTC Address (bits 6::0)	PIIX4E	Aliased from 0070h
0071h	RTC Data	PIIX4E	
0073h	RTC Data	PIIX4E	Aliased from 0071h

I/O addresses, interrupts etc.

Address	Resource	Device	Notes
0075h	RTC Data	PIIX4E	Aliased from 0071h
0077h	RTC Data	PIIX4E	Aliased from 0071h
0080h - 008Fh	DMA Low Page Register	PIIX4E	
0090h - 0091h	DMA Low Page Register (aliased)	PIIX4E	
0092h	System Control Port A (PC-AT control Port) (this port not aliased in DMA range)	PIIX4E	
0093h - 009Fh	DMA Low Page Register (aliased)	PIIX4E	
0094h	Video Display Controller		
00A0h - 00A1h	Interrupt Controller 2	PIIX4E	
00A4h - 00A5	Interrupt Controller 2 (aliased)	PIIX4E	
00A8h - 00A9	Interrupt Controller 2 (aliased)	PIIX4E	
00ACh - 00ADh	Interrupt Controller 2 (aliased)	PIIX4E	
00B0h - 00B1h	Interrupt Controller 2 (aliased)	PIIX4E	
00B2h	Advanced Power Management Control	PIIX4E	
00B3h	Advanced Power Management Status	PIIX4E	
00B4h - 00B5h	Interrupt Controller 2 (aliased)	PIIX4E	
00B8h - 00B9h	Interrupt Controller 2 (aliased)	PIIX4E	
00BCh - 00BDh	Interrupt Controller 2 (aliased)	PIIX4E	
00C0h - 00DFh	DMA Controller 2	PIIX4E	
00F0h	Clear NPX error		Resets IRQ13
00F8h - 00FFh	x87 Numeric Coprocessor		
0102h	Video Display Controller		
0170h - 0177h	Secondary Fixed Disk Controller (IDE)	PIIX4E	Not used
01F0h - 01F7h	Primary Fixed Disk Controller (IDE)	PIIX4E	
0200h - 0207h	Game I/O Port		Not used
0220h - 022Fh	Serial Port A		
0238h - 023Fh	Serial Port B		
0278h - 027Fh	Parallel Port 3		
02E8h - 02EFh	Serial Port B		
02F8h - 02FFh	Serial Port B		
0338h - 033Fh	Serial Port B		
0370h - 0375h	Secondary Diskette		
0376h	Secondary IDE		
0377h	Secondary IDE/Diskette		
0378h - 037Fh	Parallel Port 2		
03B4h - 03Bah	Monochrome Display Port		
03BCh - 03BFh	Parallel Port 1 (Primary)		
03C0h - 03CFh	Video Display Controller		

Address	Resource	Device	Notes
03D4h - 03DAh	Color Graphics Controller		
03E8h - 03EFh	Serial Port A		
03F0h - 03F5h	Diskette Controller		
03F6h - 03F7h	Primary IDE - Sec. Diskette		
03F8h - 03FFh	Serial Port A (Primary)		
0400h - 043Fh	DMA Controller 1, Extended Mode Registers	PIIX4E	
04D0h - 04D1h	Interrupt Controllers 1 and 2 Control Register		
0678h - 067Ah	Parallel Port (ECP)		
0778h - 077Ah	Parallel Port (ECP)		
07BCh - 07BEh	Parallel Port (ECP)		
0CA0 - CA3h	BMC Registers		
0CF8h	PCI CONFIG_ADDRESS Register		Located in 450NX
0CF9h	NBX Turbo and Reset control	PIIX4E	
0CFCh	PCI CONFIG_DATA Register		Located in 450NX
46E8h	Video Display Controller		

Memory map

Address Range (hex)	Amount	Function
0 to 07FFFFh	640 KB	DOS region, base system memory
0A0000h to 0BFFFFh	128 KB	Video or SMM memory
0C0000h and 0DFFFFh	128 KB	Add-in board BIOS and buffer area
0E0000h to 0FFFFFFh	128 KB	System BIOS
0E0000h to 0EFFFFh	2 MB	Extended system BIOS
FC000000h to FFFFFFFFh	64 MB	PCI memory space

Interrupts

The table overleaf recommends the logical interrupt mapping of interrupt sources; it reflects a typical configuration, but these interrupts can be changed by the user. Use the information to determine how to program each interrupt.

The actual interrupt map is defined using configuration registers in the PIIX4E and the I/O controller. I/O Redirection Registers in the I/O APIC are provided for each interrupt signal; the signals define hardware interrupt signal characteristics for APIC messages sent to local APIC(s).

NOTE

To disable either IDE controller and reuse the interrupt: if you plan to disable either IDE controller to reuse the interrupt for that controller, you must physically unplug the IDE cable from the board connector (IDE0) if a cable is present. Simply disabling the drive by configuring the SSU option does not make the interrupt available.

I/O addresses, interrupts etc.

<i>Interrupt</i>	<i>I/O APIC level</i>	<i>Description</i>
INTR	INT0	Processor interrupt
NMI	N/A	NMI from PIC to processor
IRQ1	INT1	Keyboard interrupt
Cascade	INT2	Interrupt signal from second 8259 in PIIX4E
IRQ3	INT3	Serial port A or B interrupt from SIO device (user can configure)
IRQ4	INT4	Serial port A or B interrupt from SIO device (user can configure)
IRQ5	INT5	Parallel port II
IRQ6	INT6	Diskette port
IRQ7	INT7	Parallel port
IRQ8_L	INT8	RTC interrupt
IRQ9	INT9	Signal control interrupt (SCI) used by ACPI-compliant OS
IRQ10	INT10	
IRQ11	INT11	
IRQ12	INT12	Mouse interrupt
	INT13	
IRQ14	INT14	Compatibility IDE interrupt from primary channel IDE devices 0 and 1
IRQ15	INT15	
SMI_L		System management interrupt—general purpose indicator sourced by the PIIX4E and BMC through the PID to the processors

7 CONFIGURATION SOFTWARE AND UTILITIES

This chapter describes the Power-on Self Test (POST) and system configuration utilities.

The table below briefly describes the utilities.

<i>Utility</i>	<i>Description and brief procedure</i>
BIOS Setup	<p>If the system does not have a diskette drive, or the drive is disabled or misconfigured, use Setup to enable it.</p> <p>Or, you can move the CMOS jumper on the system board from the default setting (Protect CMOS memory) to the Clear setting; this will allow most system configurations to boot.</p> <p>For the procedure to do this, (see the 'Mainboard' chapter for details). Then run the SSU to configure the system.</p>
Server Setup Utility (SSU)	<p>Use for extended system configuration of onboard resources and add-in boards, viewing the system event log (SEL), setting boot device priority, or setting system security options.</p> <p>The SSU can only be run from a set of DOS-bootable diskettes. See the detailed information starting on page 13 of this chapter on how to make a set of SSU diskettes.</p> <p>Information entered via the SSU overrides information entered via Setup.</p>
Emergency Management Port (EMP) Console	Use to access and monitor the server remotely.
FRUSDR Load Utility	Use to update the Field Replacement Unit (FRU), Sensor Data Record (SDR), and Desktop Management Interface (DMI) flash components.
BIOS Update Utility	Use to update the BIOS or recover from a corrupted BIOS update.
Firmware Update Utility	Use to update BMC flash ROM.
Symbios SCSI Utility	Use to configure or view the settings of the SCSI host adapters and onboard SCSI devices in the system.

Hot keys

Use the keyboard's numeric pad to enter numbers and symbols.

<i>To do this:</i>	<i>Press these keys</i>
Clear memory and reload the operating system—this is a system reset.	<Ctrl+Alt+Del>
Secure your system immediately.	<Ctrl+Alt>+hotkey (Set your hot-key combination with the SSU or Setup.)
Enter BIOS Setup during POST BIOS.	F2
Abort memory test during BIOS POST.	ESC (press while BIOS is updating memory size on screen)

Power-on self test (POST)

Each time you turn on the system, POST starts running. POST checks the baseboard, processors, memory, keyboard, and most installed peripheral devices. During the memory test, POST displays the amount of memory it is able to access and test. The length of time needed to test memory depends on the amount of memory installed. POST is stored in flash memory.

1. Turn on your video monitor and system. After a few seconds, POST begins to run.
2. After the memory test, these screen prompts and messages appear:

Keyboard Detected

Mouse Initialised

Press <F2> to enter Setup

3. If you do not press <F2> and do NOT have a device with an OS loaded, the above message remains for a few seconds while the boot process continues, and the system beeps once. Then this message appears:

Operating System not found

If you do not press <F2>, the boot process continues and this message appears:

Press <Ctrl><C> to enter SCSI Utility

- ◇ Press <Ctrl+C> if you want to enter the SCSI utility. When the utility opens, follow the displayed instructions to configure the onboard SCSI host adapter settings and to run the SCSI utilities. If you do not enter the SCSI utility, the boot process continues.
4. Press <Esc> during POST to access a boot menu when POST finishes. From this menu, you can choose the boot device or enter BIOS Setup.

After POST completes, the system beeps once.

What appears on the screen after this depends on if you have an OS loaded and if so, which one.

If the system halts before POST completes running, it emits a beep code indicating a critical system error that requires immediate attention. If POST can display a message on the video display screen, the speaker beeps twice as the message appears.

Note the screen display and write down the beep code you hear; this information is useful for your service representative. For a listing of beep codes and error messages that POST can generate, see the chapter on 'Solving Problems'.

Using BIOS setup

Use setup to change the system configuration defaults. You can run setup with or without an OS being present. Setup stores most of the configuration values in battery-backed CMOS; the rest of the values are stored in flash memory. The values take effect when you boot the system. POST uses these values to configure the hardware; if the values and the actual hardware do not agree, POST generates an error message. You must then run setup to specify the correct configuration.

Run setup: you can run setup to modify any standard PC-AT baseboard feature such as:

- ◆ Select diskette drive
- ◆ Select parallel port
- ◆ Select serial port
- ◆ Set time/date (to be stored in RTC)
- ◆ Configure IDE hard drive
- ◆ Specify boot device sequence
- ◆ Enable SCSI BIOS

Run SSU, not setup: you must run the SSU instead of setup to do the following:

- ◆ Enter or change information about a board
- ◆ Alter system resources (e.g., interrupts, memory addresses, I/O assignments) to user-selected choices instead of choices selected by the BIOS resource manager

Record your setup settings

If the default values ever need to be restored (after a CMOS clear, for example), you must run Setup again. Referring to the worksheets could make your task easier.

If you cannot access setup

If the diskette drive is misconfigured so that you cannot access it to run a utility from a diskette, you might need to clear CMOS memory. You must open the system, change a jumper setting, use Setup to check and set diskette drive options, and change the jumper back. For a step-by-step procedure, see the chapter detailing the 'Mainboard'.

Starting setup

You can enter and start setup under several conditions:

- ◆ When you turn on the system, after POST completes the memory test
- ◆ When you reboot the system by pressing <Ctrl+Alt+Del> while at the DOS operating system prompt
- ◆ When you have moved the CMOS jumper on the baseboard to the "Clear CMOS" position (enabled); for a step-by-step procedure, see the chapter detailing the 'Mainboard'.

In the three conditions listed above, after rebooting, you will see this prompt:

Press <F2> to enter SETUP

In a fourth condition, when CMOS/NVRAM has been corrupted, you will see other prompts but not the <F2> prompt:

Warning: cmos checksum invalid

Warning: cmos time and date not set

In this condition, the BIOS will load default values for CMOS and attempt to boot.

Setup menus

Setup has six major menus and several submenus:

1. Main menu

- ◇ Primary IDE Master and Slave
- ◇ Keyboard Features

2. Advanced menu

- ◇ PCI Configuration
 - PCI Device, Embedded SCSI
 - PCI Devices
- ◇ I/O Device Configuration
- ◇ Advanced Chipset Control

3. Security menu

4. Server menu

- ◇ System Management
- ◇ Console Redirection

5. Boot menu

- ◇ Boot Device Priority
- ◇ Hard Drive

6. Exit menu

Control keys

To:	Press:
Get general help	<F1> or <Atl+H>
Move between menus	← →
Go to the previous item	↑
Go to the next Item	↓
Change the value of an item	+ or -
Select an item or display a submenu	<Enter>
Leave a submenu or exit Setup	<Esc>
Reset to Setup defaults	<F9>
Save and exit Setup	<F10>

When you see this:	What it means:
On screen, an option is shown but you cannot select it or move to that field.	You cannot change or configure the option in that menu screen. Either the option is autoconfigured or autodetected, or you must use a different Setup screen, or you must use the SSU.
On screen, the phrase Press Enter appears next to the option.	Press <Enter> to display a submenu that is either a separate full-screen menu or a pop-up menu with one or more choices.

The rest of this section lists the features that display onscreen after you press <F2> to enter setup. Not all of the option choices are described, because (1) a few are not user-selectable but are displayed for your information, and (2) many of the choices are relatively self-explanatory.

Main menu

This table lists the selections you can make on the Main Menu itself. Use the submenus for other selections. Default values are in **bold**.

Feature	Choices	Description
System Time	HH:MM:SS	Sets the system time.
System Date	MM/DD/YYYY	Sets the system date.
Legacy Diskette A:	Disabled 360 KB 720 KB 1.44 MB 2.88 MB	Selects the diskette type.
Legacy Diskette B:	Disabled 360 KB 720 KB 1.44 MB 2.88 MB	Selects the diskette type.
Hard Disk Pre-delay	Disabled 3, 6, 9, 12, 15, 21, or 30 seconds	Adds a delay before the first BIOS access of a hard disk drive. Some hard disk drives hang if accessed before they initialise themselves. This delay ensures the hard disk drive has initialised after powerup, before being accessed.
Primary Master	N/A	Enters submenu.
Primary Slave	N/A	Enters submenu.
Keyboard Features	N/A	Enters submenu.
Language	English (US) Spanish Italian French German Japanese (Kanji)	Selects which language BIOS displays.

NOTE

Serial redirection does not work with Kanji.

Configuration and software utilities

Primary master and slave submenu

In the following table, the features other than "Type" appear only for Type Auto if a drive is detected.

Feature	Choices	Description
Type	Auto None CD-ROM IDE Removable ATAPI Removable User	Auto allows the system to attempt autodetection of the drive type. None informs the system to ignore this drive. CD-ROM allows the manual entry of fields described below. User allows the manual entry of all fields described below.
Cylinders	1 to 2048	Number of Cylinders on Drive. This field is changeable only for Type User. This field is informational only for Type Auto.
Heads	1 to 16	Number of read/write heads on drive. This field is available only for Type User. This field is informational only for Type Auto.
Sectors	1 to 64	Number of sectors per track. This field is available only for Type User. This field is informational only for Type Auto.
Maximum Capacity	N/A	Computed size of drive from cylinders, heads, and sectors entered. This field is available only for Type User. This field is informational only for Type Auto.
Multi-Sector Transfers	Disabled 2, 4, 8, or 16 sectors	Determines the number of sectors per block for multisector transfers. This field is informational only for Type Auto.
LBA Mode Control	Disabled Enabled	Enabling LBA causes logical block addressing to be used in place of cylinders, heads, and sectors. This field is informational only for Type Auto.
32 Bit I/O	Disabled Enabled	Enabling allows 32-bit IDE data transfers. This field is informational only for Type Auto.
Transfer Mode	Standard Fast PIO 1 Fast PIO 2 Fast PIO 3 Fast PIO 4	Selects the method for moving data to and from the drive. This field is informational only for Type Auto.
Ultra DMA	Disabled Enabled	For use with Ultra DMA drives. This field is information only for Type Auto.

Keyboard features submenu

Feature	Choices	Description
Num Lock	Auto On Off	Selects poweron state for Num Lock.
Key Click	Disabled Enabled	Enables or disables key click.
Keyboard auto-repeat rate	30, 26.7, 21.8, 18.5, 13.3, 10, 6, or 2 per second	Selects key repeat rate.
Keyboard auto-repeat delay	1/4 sec 1/2 sec 3/4 sec 1 sec	Selects delay before key repeat.

Advanced menu

You can make the following selections on the Advanced Menu itself. Use the submenus for the three other selections that appear on the Advanced Menu.

Feature	Choices	Description
Plug and Play OS	No Yes	Select Yes if you are booting a Plug and Play-capable OS.
Reset Configuration Data	No Yes	Select Yes if you want to clear the system configuration data during next boot. System automatically resets to No in next boot.
PCI Configuration	N/A	Enters submenu.
I/O Device Configuration	N/A	Enters submenu.
Use Multiprocessor Specification	1.1 1.4	Selects the version of multiprocessor specification to use. Some operating systems require version 1.1 for compatibility reasons.
Large Disk Access Mode	LBA CHS	Applies to IDE drives only; refers to the method used to access the drive. Most OSs use logical block addressing (LBA); some use cylinder head sector (CHS). To verify method, consult OS documentation.
Pause Before Boot	Enabled Disabled	Enables five-second pause before booting OS.
Advanced Chipset Control	N/A	Enters submenu.

PCI configuration submenu

The PCI Configuration Menu contains selections that access other submenus.

PCI device, embedded SCSI submenu

Feature	Choices	Description
Option ROM Scan	Enabled Disabled	Enables option ROM scan of the selected device.
Enable Master	Disabled Enabled	Enables selected device as a PCI bus master.
Latency Timer	Default 0020h 0040h 0060h 0080h 00A0h 00C0h 00E0h	Minimum guaranteed time, in units of PCI bus clocks, that a device can be master on a PCI bus. Typically, option ROM code overwrites the value set by the BIOS.

PCI devices submenu

Feature	Choices	Description
Option ROM Scan	Enabled Disabled	Enables option ROM scan of all devices other than the onboard SCSI controllers.
Enable Master	Enabled Disabled	Enables all devices, other than the onboard SCSI controllers, as a PCI bus master.
Latency Timer	Default 020h 040h 060h 080h 0A0h 0C0h 0E0h	Minimum guaranteed time, in units of PCI bus clocks, that a device can be master on a PCI bus. Typically, option ROM code overwrites the value set by the BIOS.

Configuration and software utilities

I/O device configuration submenu

Feature	Choices	Description
Serial Port A	Disabled Enabled Auto OS Controlled	Auto forces BIOS to configure the port. OS Controlled displays when OS controls the port.
Base I/O Address	3F8 2F8 3E8 2E8	Selects the base I/O address for COM port A.
Interrupt	IRQ 4 IRQ 3	Selects the IRQ for COM port A.
Serial Port B	Disabled Enabled Auto OS Controlled	Auto forces BIOS to configure the port. OS Controlled displays when OS controls the port.
Mode	Normal IrDA ASK-IR	Selects mode for COM port B.
Base I/O Address	3F8 2F8 3E8 2E8	Selects the base I/O address for COM port B.
Interrupt	IRQ 4 IRQ 3	Selects the interrupt for COM port B.
Parallel Port	Disabled Enabled Auto OS Controlled	Auto forces BIOS to configure the port. OS Controlled displays when OS controls the port.
Mode	ECP Output only Bidirectional EPP	Selects mode for parallel port.
Base I/O Address	378 278	Selects the base I/O address for parallel port.
Interrupt	IRQ 5 IRQ 7	Selects the interrupt for parallel port.
DMA channel	DMA 1 DMA 3	Selects the DMA channel for parallel port.
Floppy disk controller	Disabled Enabled	Enables onboard diskette controller.
Base I/O Address	Primary Secondary	Sets the base I/O address for the diskette controller.
PS/2 Mouse	Auto Disabled Enabled	Enables or disables onboard mouse. Disabling the mouse frees up IRQ 12. If this feature is enabled, the OS can determine whether to enable or disable the mouse.

Advanced chipset control submenu

Feature	Option	Description
Address Bit Permuting	Disabled Enabled	To be enabled, there must be a power of 2 number of rows, all rows must be the same size, and all populated rows must be adjacent and start at row 0. Two-way or four-way permuting is set automatically based on memory configuration.
Base RAM Step	1 MB 1 KB Every location	Tests base memory once per MB, once per KB, or every location.
Extended RAM Step	1 MB 1 KB Every location	Tests extended memory once per MB, once per KB, or every location.
L2 Cache	Enabled Disabled	When enabled, the secondary cache is sized and enabled. For Core Clock Frequency-to-System Bus ratios equal to two, BIOS automatically disables the L2 cache.
ISA Expansion Aliasing	Enabled Disabled	When enabled, every I/O access with an address in the range x100-x3FFh, x500-x7FFh, x900-xBFF, and xD00-xFFFh is internally aliased to the range 0100-03FFh before any other address range checking is performed.
Memory Scrubbing	Disabled Enabled	When enabled, BIOS automatically detects and corrects SBEs.
Restreaming Buffer	Enabled Disabled	When enabled, the data returned and buffered for a Delayed Inbound Read can be reaccessed following a disconnect.
Read Prefetch for PXB0A	N/A	Information field only. Configures the number of Dwords that are prefetched on Memory Read Multiple commands.
Read Prefetch for PBX0B	N/A	Information field only. Configures the number of Dwords that are prefetched on Memory Read Multiple commands.

Security menu

You can make the following selections on the Security Menu. Enabling the Supervisor Password field requires a password for entering Setup. The passwords are not case sensitive.

Feature	Choices	Description
Administrator Password is	Clear Set	Status only; user cannot modify. Once set, this can be disabled by setting it to a null string or by clearing password jumper on the mainboard (see the 'Mainboard' chapter for details)
User Password is	Clear Set	Status only; user cannot modify. Once set, this can be disabled by setting it to a null string or by clearing password jumper on the mainboard (see the 'Mainboard' chapter for details)
Set Administrative Password	Press Enter	When the <Enter> key is pressed, the user is prompted for a password; press ESC key to abort. Once set, this can be disabled by setting it to a null string or by clearing password jumper on the mainboard. (see the 'Mainboard' chapter for details)
Set User Password	Press Enter	When the <Enter> key is pressed, the user is prompted for a password; press ESC key to abort. Once set, this can be disabled by setting it to a null string or by clearing password jumper on the mainboard. (see the 'Mainboard chapter for details)
Password on Boot	Disabled Enabled	If enabled and the user password is set, the system prompts the user for a password before the system boots.
Fixed Disk Boot Sector	Normal Write Protect	Write-protects boot sector on hard disk to protect against viruses.

Configuration and software utilities

Feature	Choices	Description
System Backup Reminder	Disabled Daily Weekly Monthly	Displays system-backup reminder message at boot.
Virus Check Reminder	Disabled Daily Weekly Monthly	Displays virus-check reminder message at boot.
Secure Mode Timer	Disabled 1, 2, 5, 10, or 20 min 1 or 2 hr	Period of keyboard or PS/2 mouse inactivity specified for secure mode to activate. A password is required for secure mode to function. Cannot be enabled unless at least one password is enabled.
Secure Mode Hot Key (Ctrl-Alt-)	[] [A, B, ..., Z] [0-9]	Key assigned to invoke the secure mode feature. Cannot be enabled unless at least one password is enabled. Can be disabled by entering a new key followed by a backspace or by entering <Delete>.
Secure Mode Boot	Disabled Enabled	System boots in secure mode. The user must enter a password to unlock the system. Cannot be enabled unless at least one password is enabled.
Video Blanking	Disabled Enabled	Blank video when secure mode is activated. The user must enter a password to unlock the system. Cannot be enabled unless at least one password is enabled.
Floppy Write Protect	Disabled Enabled	When secure mode is activated, the diskette drive is write protected. The user must enter a password to re-enable diskette writes. Cannot be enabled unless at least one password is enabled.

Server menu

Feature	Choices	Description
System Management	N/A	Enters submenu.
Console Redirection	N/A	Enters submenu.
Processor Retest	No Yes	Instructs BIOS to clear historical processor status and to retest all processors on next boot.

System management submenu

Feature	Choices	Description
Server Management Mode	Disabled Enabled	Enabled loads Server Management Interrupt handler, which handles system errors.
System Event Logging	Disabled Enabled	Enabled forces BIOS and BMC to log system events.
Clear Event Log	Disabled Enabled	Enabled clears the system event log.
Assert NMI on AERR	Disabled Enabled	Enabled generates a nonmaskable interrupt (NMI) on an address parity error (AERR).
Assert NMI on BERR	Disabled Enabled	Enabled generates an NMI on a bus error (BERR).
Assert NMI on PERR	Disabled Enabled	Enabled generates an NMI on a parity error (PERR). To activate this feature, the system error (SERR) option must be enabled.
Assert NMI on SERR	Disabled Enabled	Enabled generates an NMI on SERR.
Enabled Host Bus Error	Disabled Enabled	Enables host single-bit errors (SBEs) and multiple-bit errors (MBEs).

Console redirection submenu

<i>Feature</i>	<i>Choices</i>	<i>Description</i>
COM Port Address	Disabled 3F8 2F8 3E8	When enabled, console redirection uses the I/O port specified. When disabled, console redirection is completely disabled.
IRQ #	None, 3, or 4	When console redirection is enabled, this displays the IRQ assigned per the address chosen in the COM Port Address field.
Baud Rate	9600 19.2k 38.4k 115.2k	When console redirection is enabled, use the baud rate specified. When the Emergency Management Port (EMP) shares the COM port as console redirection, the baud rate must be set to 19.2k to match EMP baud rate, unless the autobaud feature is used.
Flow Control	No flow control CTS/RTS XON/XOFF CTS/RTS + CD	None disallows flow control. CTS/RTS is hardware flow control. XON/XOFF is software flow control. CTS/RTS + CD is hardware plus carrier-detect flow control.

Boot menu

You can make the following selections on the Boot Menu itself.

<i>Feature</i>	<i>Choices</i>	<i>Description</i>
Floppy Check	Disabled Enabled	If Enabled, system verifies diskette type on boot. Disabled results in a faster boot.
Multi-boot Support	Disabled Enabled	Enable this option only if the total number of hard drives is less than eight.
Boot Device Priority	N/A	Enters submenu.
Hard Drive	N/A	Enters submenu.
Removable Devices	N/A	Enters submenu.
Maximum Number of I2O Drives	1 4	Selects the maximum number of I2O drives assigned a DOS drive letter.
Message Timeout Multiplier	1, 2, 8, 10, 50, 100, 1000	All timeout values are multiplied by this number.

Boot device priority submenu

Use the up- or down-arrow keys to select a device. Press the <+> or <-> keys to move the device higher or lower in the boot priority list.

<i>Boot Priority</i>	<i>Device</i>	<i>Description</i>
1.	Diskette Drive	Attempts to boot from drive A.
2.	Removable Devices	Attempts to boot from a removable media device.
3.	Hard Drive	Attempts to boot from a hard drive device.
4.	ATAPI CD-ROM Drive	Attempts to boot from an ATAPI CD-ROM drive.

Hard Drive submenu

For options on this menu, use the up or down arrow keys to select a device. Press the <+> or <-> keys to move the device higher or lower in the boot priority list.

<i>Option</i>	<i>Description</i>
1. Drive #1 (or actual drive string)	N/A
2. Other bootable cards (additional entries for each drive that has a PnP header)	Covers all the boot devices that are not reported to the system BIOS through the BIOS boot specification mechanism.

Exit menu

You can make the following selections on the Exit Menu. Select an option using the up or down arrow keys. Press <Enter> to run the option. Pressing <Esc> does not exit this menu. You must select one of the items from the menu or menu bar to exit.

Choices	Description
Exit Saving Changes	Exits after writing all modified Setup item values to NVRAM.
Exit Discarding Changes	Exits leaving NVRAM unmodified and continues POST. User is prompted if any of the Setup fields were modified.
Load Setup Defaults	Loads default values for all Setup items.
Load Custom Defaults	Loads settings from custom defaults.
Save Custom Defaults	Saves present Setup values to custom defaults. These settings override the standard BIOS defaults; BIOS loads these values when CMOS is corrupted or when the Clear CMOS jumper is in the clear position.
<hr/> CAUTION <hr/>	
	<i>Verify that custom defaults are saved before saving. Failure to do so can result in system malfunction.</i>
Discard Changes	Reads previous values of all Setup items from NVRAM.
Save Changes	Writes all Setup item values to NVRAM.

Using the system setup utility (SSU)

The SSU is on the configuration software CD shipped with the server. The SSU provides a graphical user interface (GUI) over an extensible framework for server configuration. The SSU framework supports the following functions and capabilities:

- ◆ Assigns resources to baseboard devices and add-in boards before loading the OS
- ◆ Lets you specify boot device order and system security options
- ◆ Permits viewing and clearing of the system event log (SEL)
- ◆ Permits viewing of the system FRU and SDRs
- ◆ Allows troubleshooting of the server when the OS is not operational
- ◆ Provides a system-level view of the server's I/O devices

When to run the SSU

The SSU is a DOS-based utility that supports extended system configuration operations for onboard resources and add-in boards. Use the SSU when you need to:

- ◆ Add and remove boards affecting the assignment of resources (ports, memory, IRQs, DMA)
- ◆ Modify the server's boot device order or security settings
- ◆ Change the server configuration settings
- ◆ Save the server configuration
- ◆ View or clear the SEL
- ◆ View FRU information
- ◆ View the SDR table

If you install or remove an ISA add-in board, you must run the SSU to reconfigure the server. Running the SSU is optional for PCI and Plug and Play ISA add-in boards.

The SSU is PCI-aware and complies with the ISA Plug and Play specifications; it works with any compliant configuration (.CFG) files supplied by the peripheral device manufacturer.

The baseboard comes with a .CFG file describing the characteristics of the board and the system resources it requires. The configuration registers on PCI and ISA Plug and Play add-in boards contain the same type of information in a .CFG file. Some ISA boards also come with a .CFG file.

The SSU uses the information provided by .CFG files, configuration registers, flash memory, and the information that you enter, to specify a system configuration. The SSU then writes the configuration information to flash memory.

The SSU stores configuration values in flash memory. These values take effect when you boot the server. POST checks the values against the actual hardware configuration; if the values do not agree, POST generates an error message. You must then run the SSU to specify the correct configuration before the server boots.

The SSU always includes a checksum with the configuration data so the BIOS can detect any potential data corruption before the actual hardware configuration takes place.

What you need to do

You must make a set of diskettes from the master system CD.

The SSU cannot run directly from the CD due to memory restrictions. You must copy the SSU from the CD to the diskettes and follow the instructions in the included README.TXT file to prepare the diskettes.

If your diskette drive is disabled or improperly configured, you must use the flash-resident Setup utility to enable it so you can use the SSU. If necessary, you can disable the drive after exiting the SSU. Information entered using the SSU overrides any entered using Setup.

Running the SSU

Running the SSU locally

Running the ssu.bat file provided on the SSU media starts the SSU. If the server boots directly from the SSU media, the ssu.bat file runs automatically. If the server boots from different media, the SSU can be started manually or by another application. When the utility starts in the local execution mode (the default mode), the SSU accepts input from the keyboard and/or mouse. The SSU presents a VGA-based GUI on the primary monitor.

The SSU runs from writable, nonwritable, removable, and nonremovable media. If the SSU is run from nonwritable media, user preference settings (like screen colours) cannot be saved.

The SSU supports the ROM-DOS V6.22 OS. It can run on other ROM-DOS compatible OSs, but they are not supported. The SSU **will not** operate from a “DOS window” running under an OS like Windows.

Running the SSU remotely

To run the SSU remotely, you must invoke the SSU.BAT file with the /t switch and redirect the text-mode output via BIOS console redirect.

Starting the SSU

The SSU is a collection of task-oriented modules plugged into a common framework called the Application Framework (AF). The AF provides a launching point for individual tasks and a location for setting customisation information.

1. Turn on your video monitor and your system.
2. After creating a set of SSU diskettes from the CD, insert the first SSU diskette in drive A. Press the reset button or <Ctrl+Alt+Del> to reboot your server from the diskette.
3. When the SSU title appears on the screen, press <Enter> to continue.
4. The mouse driver loads if it is available; press <Enter> to continue.

This message appears:

Please wait while the Application Framework loads....

When the main window of the SSU appears, you can customize the UI before continuing. See ‘Customising the SSU’ later in this chapter.

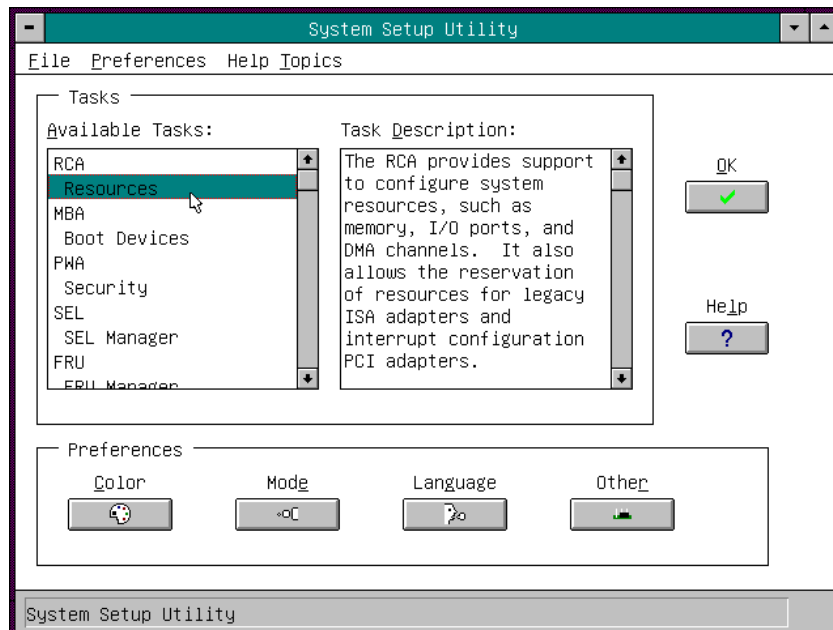

SSU main window

Customising the SSU

You can customise the UI according to your preferences. The AF sets these preferences and saves them in the AF.INI file so that they take effect the next time you start the SSU. Use these four user-customisable settings:

- ◆ **Color**—lets you change the default colors associated with different items on the screen to predefined color combinations. The changes are instantaneous.
- ◆ **Mode**—lets you set the desired expertise level.
 - ◇ Novice
 - ◇ Intermediate
 - ◇ Expert

The expertise level determines which tasks are visible in the Available Tasks section and what actions each task performs. For a new mode setting to take effect, you must exit the SSU and restart it. In the current implementation, there is no distinction between these three different modes.

- ◆ **Language**—lets you change the strings in the SSU to the appropriate language. For a new language setting to take effect, you must exit the SSU and restart it.
- ◆ **Other**—lets you change other miscellaneous options in the SSU. The changes are instantaneous.

To change the interface default values:

- ◆ Use the mouse to click on the proper button in the Preferences section of the SSU Main window.

OR

- ◆ Use the tab and arrow keys to highlight the desired button, and press the spacebar or <Enter>.

OR

- ◆ Access the menu bar with the mouse or hot keys (Alt + underlined letter).

NOTE

If you run the SSU from nonwritable media, these preferences will be lost when you exit the SSU.

Launching a task

It is possible to have many tasks open at the same time, although some tasks might require complete control to avoid possible conflicts. The tasks achieve complete control by commanding the centre of operation until you close the task window.

To launch a task:

- ◆ In the SSU Main window, double-click on the task name under Available Tasks to display the main window for that task.

OR

- ◆ Highlight the task name, and click <OK>.

OR

- ◆ Use the tab and arrow keys to highlight the desired button, and press the spacebar or <Enter>.

Resource configuration add-in (RCA) window

The RCA provides three major functions:

- ◆ Creates representations of devices that cannot be discovered by the system (ISA boards)
- ◆ Modifies the contents of the system by adding and removing devices
- ◆ Modifies the resources used by devices

You can use the RCA window to define or add an ISA board by clicking on the appropriate button. To remove an ISA board, highlight the board in the Devices section of the screen before clicking on the button. You can add only as many ISA boards as ISA slots available.

1. From the SSU main window, launch the RCA by selecting the 'Resources' task under the RCA heading in the task box.
2. When the RCA window appears, it displays messages similar to the following:

```
Baseboard: System Board
PCI Card: Bus 00 dev 00 -- Host Processor Bridge
PCI Card: Bus 00 dev 0D -- Multifunction Controller
PCI Card: Bus 00 dev 0F -- Ethernet Controller
PCI Card: Bus 00 dev 12 -- Multifunction Controller
PCI Card: Bus 00 dev 14 -- VGA Controller
```

3. To configure a device, click on it or select its name in the Devices section of the RCA window and press the spacebar or <Enter>.
4. You can close the RCA window and return to the AF by clicking on the Close button. Any changes made will be kept in memory for use by the RCA when it is rerun.
5. Save all changes by clicking <Save>. Saving writes your current configuration to nonvolatile storage where it will be available to the system after every reboot.
6. Closing the window by clicking on the system menu (the dash in the upper-left corner) discards all changes.

Defining an ISA board

An ISA board usually comes with a vendor-created .CFG file that specifies the resources the card requires to function properly. If the .CFG file is unavailable, you must manually create it or define the board through the SSU. Defining an ISA board consists of specifying the name of the board and the resources it consumes. This allows the RCA to consider the ISA board resource requirements when the RCA tries to resolve conflicts. BIOS also uses this information to configure hardware when the system is booted.

1. To add or remove ISA board resources, click on the appropriate resource buttons, select the desired value, and click <Add> or <Remove>.
2. After you complete the necessary information, click <Save>.
3. To edit a board, click <Load> to retrieve the board information. After making changes, click <Save>.
4. To create a board, click <New>.
5. To remove a current definition of a board, click <Delete>.

Adding and removing ISA boards

Adding and removing boards through the RCA provides a way for the RCA to run its conflict detection algorithms on the resources requested by the boards. This alerts you to any possible problems with that particular board in the current configuration.

To add an ISA board:

1. Click <Add ISA Board> in the RCA window.
2. Specify the directory for the .CFG file.
3. Select the file and click <OK>.

To remove an ISA board:

1. Select a valid ISA board in the Devices section of the RCA window.
2. Click <Remove ISA Board>.

Modifying resources

Modifying the resources of a device may be necessary to accommodate certain OSs, applications, and drivers. It may also be necessary to modify resources to resolve a conflict.

To modify the resources associated with a device:

1. Highlight the device in the Devices section of the RCA window.
2. Press the spacebar or <Enter>, or double-click on the entry.

This displays the functions of the selected device along with possible choices and the resources associated with those choices.

To make a modification:

1. Highlight the function in the Configuration window.
2. Press the spacebar or <Enter>, or double-click on the entry (this updates the choice and resource lists).
3. Press the tab key to get to the choice list, and press <Enter>.
4. Use the arrow keys to select a proper choice, and press <Enter> again.
5. If the choice allows multiple possible values for a particular resource, use the hot key to select a resource and press the spacebar or double-click on the resource.
6. Select the desired resource, and click <OK>.

System resource usage

Click <Resource Use> in the Configuration window to display the System Resource Usage window, which shows the resources each device consumes. This information is useful if a conflict occurs. Devices can be organised according to the resources you want to examine using the options in the Resource section of the screen. The resource information can also be written to a plain text file through this window.

Multiboot options add-in

In this window, you can change the boot priority of a device.

1. Select a device
2. Press <+> to move the device up in the list (higher priority). Press <-> to move it down.

Security add-in

In this window, you can set the User and Administrator passwords and security options.

To set the user password

1. Click <User Password>.
2. Enter the password in the first field.
3. Confirm the password by entering it again in the second field.

To change or clear the user password

1. Click <User Password>.
2. Enter the old password in the first field.
3. Enter the new password in the second field (or leave blank to clear).
4. Confirm the password by entering it again in the second field (or leave blank to clear).

To set the administrator password

1. Click <Administrator Password>.
2. Enter the password in the first field.
3. Confirm the password by entering it again in the second field.

To change or clear the administrator password

1. Click <Administrator Password>.
2. Enter the old password in the first field.
3. Enter the new password in the second field (or leave blank to clear).
4. Confirm the password by entering it again in the second field (or leave blank to clear).

Security options

In this window, you can set the other security options:

- ◆ **Hot Key**—sets a key sequence that puts the server into secure mode when the key is pressed.
- ◆ **Lock-Out Timer**—sets an interval that puts the server into secure mode when no activity occurs during the interval.
- ◆ **Secure Boot Mode**—forces the server to boot directly into secure mode.
- ◆ **Video Blanking**—turns off the video when the server is in secure mode.
- ◆ **Floppy Write**—controls access to the diskette drive when the server is in secure mode.
- ◆ **Reset/Power Switch Locking**—controls the power and reset buttons when the server is in secure mode.

System event log (SEL) viewer add-in

Clicking on the SEL add-in task brings up the SEL viewer add-in, which allows users to:

- ◆ Examine SEL records via the BMC in hex or verbose mode
- ◆ Examine SEL records by sensor or event type in hex or verbose mode
- ◆ Examine SEL records from a previously stored binary file in hex or verbose mode
- ◆ Save SEL records to a file in either text or binary form
- ◆ Clear SEL entries from the non-volatile storage area

The SEL viewer's main window provides access to features of the add-in. Each option included on the main menu supports an accelerator key. Accelerator keys are indicated by an underlined letter in the text listing the option. The main window includes support to display the following information for each SEL entry: record identifier, event type, time stamp information, generator identifier, emv revision, sensor type, sensor number, and event description.

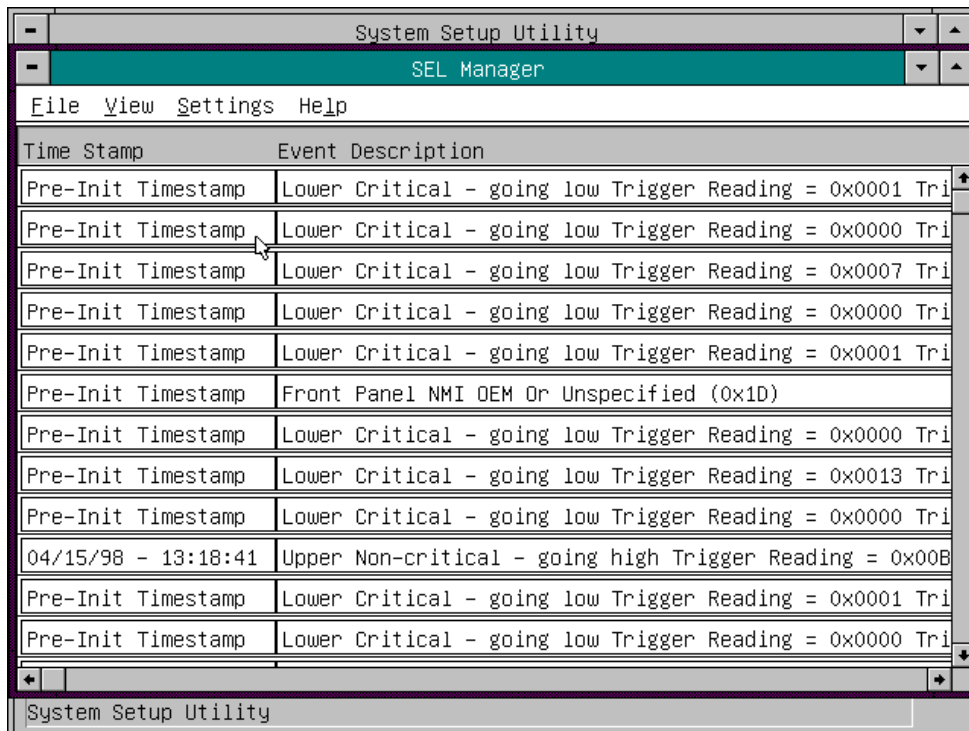

SEL viewer add-in main window

Menu	Options
File	Open SEL: Views data from previously saved SEL file Save SEL: Saves the currently loaded SEL data to a file Clear SEL: Clears the SEL data from the BMC Exit: Quits the SEL Viewer
View	SEL Info: Displays information about the SEL (display only) All Events: Displays the current SEL data from the BMC By Sensor: Displays a pop-up menu allowing you to view the data from a certain sensor type By Event: Displays a pop-up menu allowing you to view the data from a certain event type
Settings	Display Hex/Verbose: Toggles between Hex/interpreted mode of displaying the SEL records Output Text/Binary: Determines whether SEL data will be saved to the file (and under File - Save) in binary format or verbose format
Help	About: Displays the SEL Viewer version information

Sensor data record (SDR) manager add-in

In this window, you can:

- ◆ Examine all SDR records through the BMC (in either Hex or Verbose mode)
- ◆ Examine SDR records by Record type (in either Hex or Verbose mode)
- ◆ Examine SDR records from a previously stored binary file (in either Hex or Verbose mode)
- ◆ Save the SDR records to a file (in either text or binary form)

The SDR Manager can display SDR records in either raw form (hexadecimal) or in an interpreted, easy-to-understand textual form (verbose).

The SDR Manager's main window provides access to features of the add-in through menus. Each option included on the main menu supports an accelerator key. Accelerator keys are indicated by an underlined letter in the text listing the option.

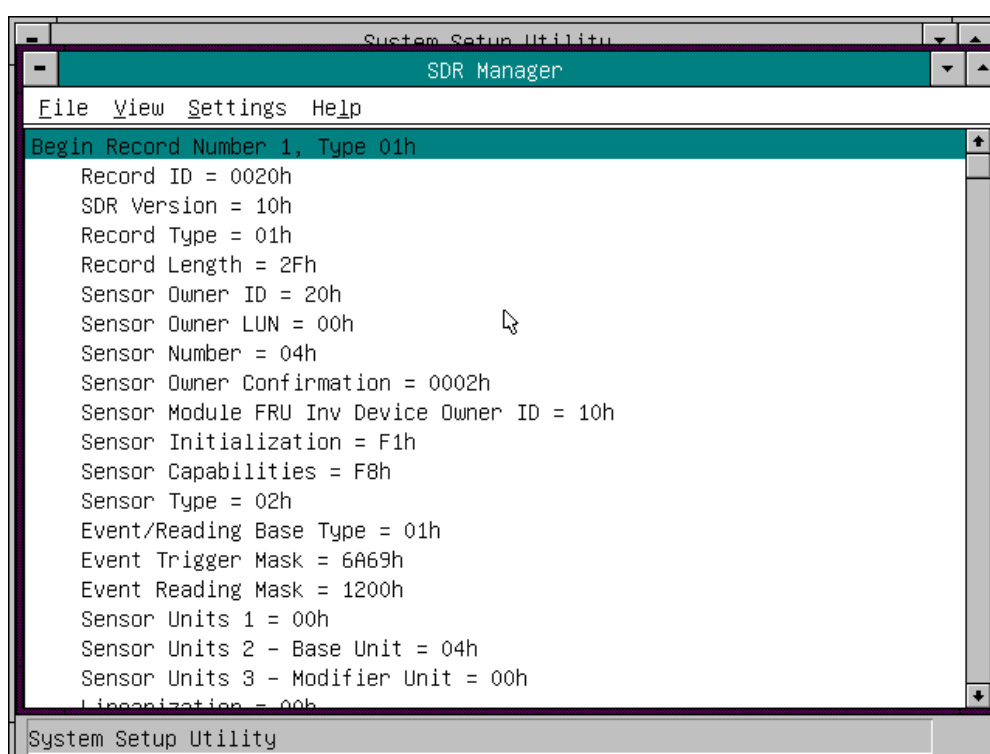

SDR manager main window

Menu	Options
File	Open FRU: Opens FRU data from a previously saved file Save SDR: Saves SDR data to a file in binary raw or verbose text format Exit: Quits the SDR Manager
View	SDR Info: Displays SDR information as returned by the GetSDRInfo interface of the BMC All Records: Displays all records in the SDR repository By Record: Displays all records in the SDR repository, sorted by record type
Settings	Display HEX: Displays SDR records in Hex format Display Verbose: Displays SDR records in verbose format Output Text: Saves SDR data in verbose format Output Binary: Saves SDR data in binary format
Help	About: Displays SDR Manager version information

Field replaceable unit (FRU) manager add-in

In this window you can:

- ◆ Examine all FRU Inventory areas on the server (in either Hex or Verbose mode)
- ◆ Examine individual FRU Inventory areas (in either Hex or Verbose mode)
- ◆ Examine FRU Inventory areas from a previously stored binary file (in either Hex or Verbose mode)
- ◆ Save the FRU Inventory areas to a file (in either text or binary form)

The FRU Manager can display the FRU Inventory areas in either raw form (hexadecimal) or in an interpreted, easy-to-understand textual form (verbose). The FRU manager's main window provides access to features of the add-in through menus. Each option included on the main menu supports an accelerator key. Accelerator keys are indicated by an underlined letter in the text listing the option.

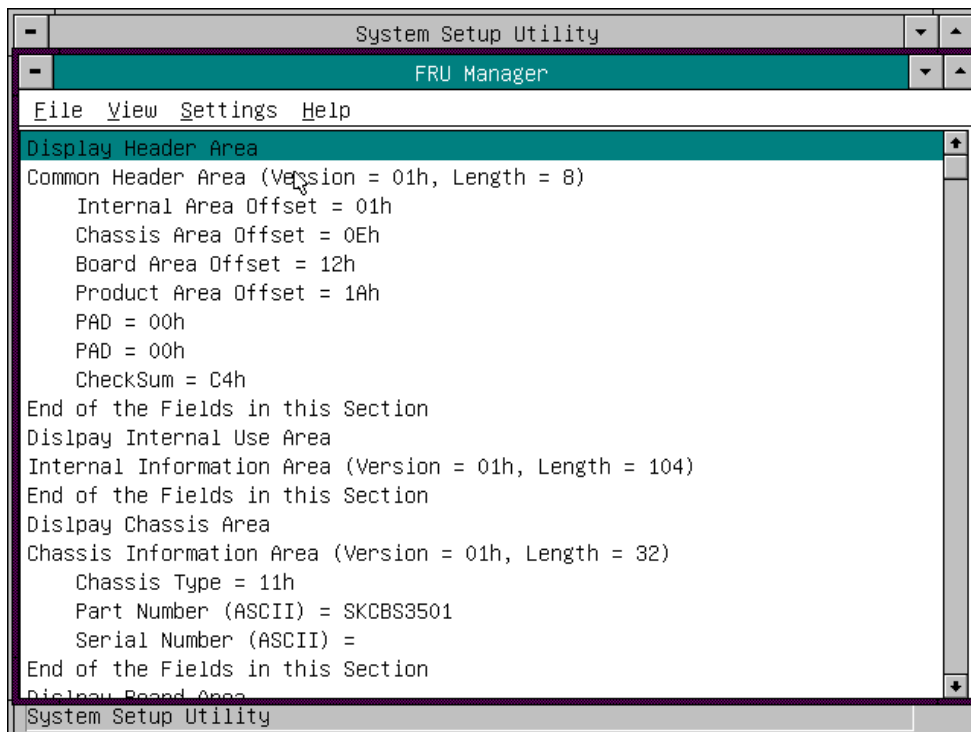

FRU manager main window

Menu	Options
File	Open FRU: Opens FRU data from a previously saved file Save FRU: Saves FRU data to a file in binary raw or verbose text format Exit: Quits the FRU Manager
View	FRU Info: Displays FRU information of the selected device All FRU Areas: Displays FRU areas of all devices By Device Type: Displays FRU areas sorted by device type
Settings	Display HEX: Displays FRU areas in Hex format Display Verbose: Displays FRU areas in verbose format Output Text: Saves FRU data in verbose format Output Binary: Saves FRU data in binary format
Help	About: Displays FRU Manager version information

Exiting the SSU

Exiting the SSU causes all windows to close.

1. Exit the SSU by opening the menu bar item File in the SSU Main window.
2. Click <Exit>

OR

Highlight Exit, and press <Enter>.

Emergency management port (EMP) console

The EMP console provides an interface, called the console manager, to the EMP. This interface allows remote server management via a modem or direct connection.

The following server control operations are available with the console manager:

- ◆ Connecting to remote servers
- ◆ Powering the server on or off
- ◆ Resetting the server
- ◆ Switching the server console between EMP active and BIOS re-direct modes

The console manager uses three management plug-ins to monitor the server: the SEL, SDR, and FRU viewers.

The console manager also has a support plug-in phonebook, which you can use to create and maintain a list of servers and their phone numbers. You can launch the Connect dialog directly from the Phonebook dialog to connect to a selected server.

How the EMP console works

The EMP shares the COM2 port with the system. When the EMP has control of the port, the port operates in command state. When the system has control of it, the port operates in redirect state. When connecting to a server, the EMP console checks to determine the current COM2 port state.

- ◆ **Command state**—the default COM2 state. In this state, the EMP console communicates with the server's firmware, allowing the client to remotely reset or power the server up or down. The client can also view the server's SEL, FRU information, or SDR table.
- ◆ **Redirect state**—the EMP console serves as a PC ANSI terminal window for BIOS console redirection. Commands typed in this terminal window are transmitted through BIOS to the server's console, and text displayed on the server console is displayed on the EMP console's terminal window. With the EMP in this state, you can remotely view boot messages, access BIOS setup, and run DOS text mode applications through the EMP console's terminal window.

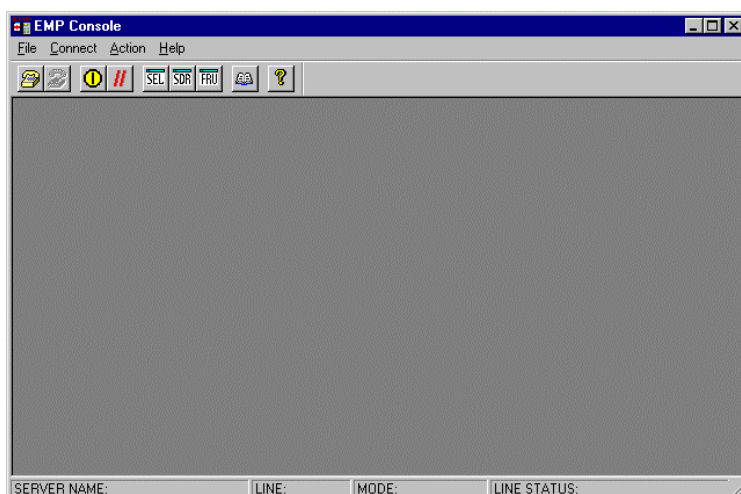

EMP console in command state

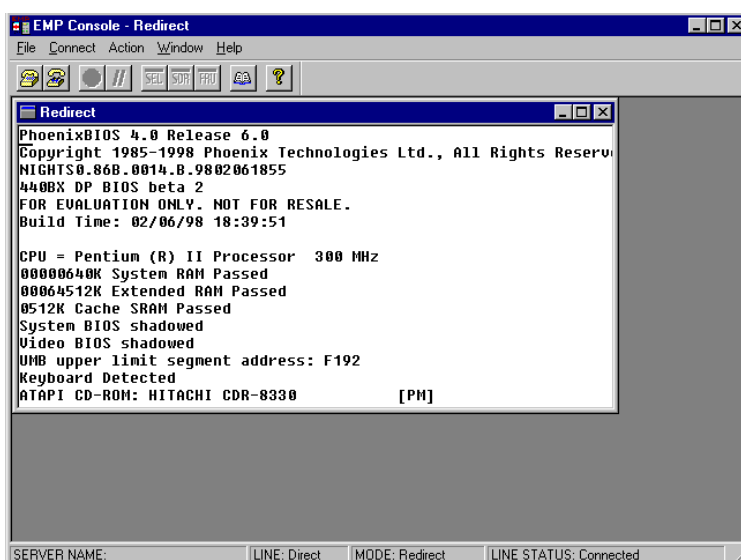

EMP console in redirect state

The screen-shot above shows the EMP console window in redirect state with the terminal window. The text that appears on the server monitor displays in the redirect window.

Availability of the various EMP console features is determined by two things: the EMP access mode selected during configuration in the System Management Submenu of the BIOS Server Menu, and whether the server's COM2 port is configured for console redirect in BIOS. The three EMP access modes are disabled, pre-boot, and always active.

EMP console access modes (server configured for console redirect)

<i>Mode</i>	<i>Server is powered off</i>	<i>During POST</i>	<i>After OS boots</i>
Disabled	Redirect window appears, but is blank	Redirect window	Redirect window
Pre-boot	EMP commands available	Redirect window*	Redirect window
Always Active	EMP commands available	Redirect window*	EMP commands available

* You can modify the operation mode by selections in the POST reset and POST power-up dialogs. These are server control dialogs available with the EMP Console.

EMP console access modes (server NOT configured for console redirect)

Mode	Server is powered off	During POST	After OS boots
Disabled	Redirect window appears, but is blank	Redirect window appears, but is blank	Redirect window appears, but is blank
Pre-boot	EMP commands available	EMP commands available	Redirect window appears, but is blank
Always Active	EMP commands available	EMP commands available	EMP commands available

EMP console requirements

This section outlines the requirements and configurations necessary for using the EMP console.

Operating systems:

- ◆ Windows 95/98
 - ◇ 16 MB of RAM, 32 MB recommended
 - ◇ 20 MB disk space
- ◆ Windows NT
 - ◇ Windows NT 4.0 or later
 - ◇ 24 MB of RAM, 32 MB recommended
 - ◇ 20 MB disk space

Client Configuration: The EMP console will support all COM ports on the client system, along with any Windows NT/95 compatible modem.

Server Configuration: The EMP console requires that the server's COM2 port be connected to an external modem or directly connected to a serial cable.

Direct Connect Configuration: A null modem serial cable is needed. Connect one end of the cable into the COM2 port of the server and the other into a port on the client machine.

Modem Configuration: On the client, the EMP console uses the Windows application program interface (API) to determine if a modem is connected and available. The EMP Console does not configure the modem; it should be preconfigured through Windows.

For modem support, the server must use a Hayes-compatible 14400 bps modem. The modem must be on the NT hardware compatibility list provided by Microsoft. The server modem must be set in autoanswer mode for the EMP console to be able to connect to it.

Setting up the server for the EMP

To use the EMP, you must configure BIOS with specific settings. Enter these settings in two submenus of the BIOS Server Menu: the System Management Submenu and the Console Redirect Submenu. The section above on BIOS settings shows all available options. The sections below focus on the settings that must be configured to use the EMP.

System management submenu

All EMP-related settings occur from the System Management Submenu of the server Main Menu. Change only the items below; all other default settings should remain the same.

EMP Password: Any time you attempt to initiate a connection, a prompt for the user password appears. If you never set up the EMP password, anyone can access the EMP by clicking <OK> through the password prompt.

In the EMP password area of the System Management Submenu, type in a password of up to eight alphanumeric characters. If the system beeps, the password was not accepted; you must enter a different password.

EMP Access Modes: Choose either disabled, pre-boot, or always active, depending on the type of EMP access needed.

EMP Restricted Mode Access: Set restricted mode to either enabled or disabled. In enabled mode, the EMP console's server control options, Power On/Off and Reset, are NOT available. In disabled mode, these options ARE available.

EMP Direct Connect/Modem Mode: Select Direct Connect if a null modem serial cable directly connects the server's COM2 port to the EMP console client machine. If they are connected via a modem, select Modem Mode.

Console redirection submenu

To use the EMP, you must set the following options exactly as noted.

COM Port Address: Select 2F8. This is the COM2 port that the EMP must use. The IRQ# setting is automatically assigned with the correct number based on the COM port address choice.

Baud Rate: Select 19.2k.

Console Type: Choose PC ANSI.

Flow Control: Choose CTS/RTS + CD.

Main EMP console window

The main EMP console window provides a graphical user interface (GUI) to access server control operations and to launch the management plug-ins. A menu and tool bar at the top of the GUI provide options to initiate plug-ins and other support features. A status bar at the bottom displays connection information like server name, line status, and mode.

Toolbar

The tool bar buttons combine server control and management plug-in options available from the Connect and Action Menus.



Connects to a selected server.



Disconnects from the currently connected server.



Powers the selected server on or off.



Resets the selected server.



Opens the SEL viewer.



Opens the SDR viewer.



Opens the FRU viewer.



Opens the phonebook.



Opens online help.

Status bar

The status bar displays at the bottom of the current window. It contains the following status information:

- ◆ **Server Name:** The name of the connected server.
- ◆ **Line:** The type of line connection (direct or modem).
- ◆ **Mode:** Either redirect or EMP, depending on whether the EMP has control of the COM2 port.
- ◆ **Line Status:** Gives status information on the server connection. For example, if a server is connected, the status bar says 'Connected'. Otherwise, the line is blank.

EMP console main menu

- ◆ File
 - ◇ **Exit:** Exits the EMP console
- ◆ Connect
 - ◇ **Disconnect:** Disconnects the server connection.
 - ◇ **[Re]Connect:** Raises the connect dialog.
 - ◇ **(A list of the five most recent connections):** Initiates connection to selected server.
- ◆ Action
 - ◇ **Power On/Off:** Powers the server on or off with POST power-up options.
 - ◇ **Reset:** Resets the server with POST reset options.
 - ◇ **SEL Viewer:** Opens the SEL viewer.
 - ◇ **SDR Viewer:** Opens the SDR viewer.
 - ◇ **FRU Viewer:** Opens the FRU viewer.
 - ◇ **Phonebook:** Opens the phonebook dialog.
- ◆ **Help:** Provides version information and help topics for the EMP console.

Server control operations

Three server control operations are available from the menu or toolbar of the main EMP console window, remote server connection, powering the server on and off, and resetting the server. The server console mode can also be switched between EMP active and BIOS redirect modes through POST power-up and reset options.

Connect to remote server

Select [Re]Connect from the Connect Menu and follow the Connect dialog, shown in the screenshot on the next page, allows you to connect to a selected server. If the client machine is already connected to a server, initiating connection generates a warning message. The message states that the existing connection will be terminated if you continue trying to initiate the new connection. You are prompted to enter the EMP password whenever a connection is attempted.

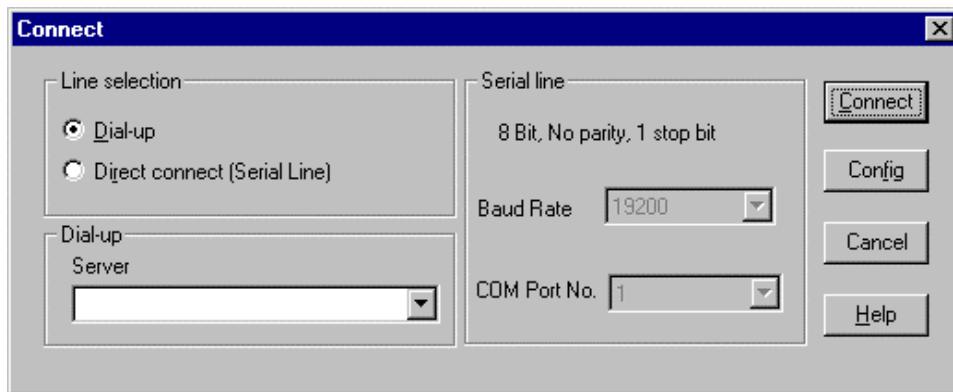

Connect dialog

Options available in the dialog are:

- ◆ **Line Selection:** Allows distinction between direct or dial-up modem connection to the server.
 - ◇ **Dial-up:** Connects to a selected server with a modem.
 - ◇ **Direct connect (Serial Line):** Connects to the selected server directly using a null modem serial cable.
- ◆ **Server:** Displays a list of available servers in a dropdown edit list box. You can select or enter a server name; a server must be selected when the line selection is dial-up.
- ◆ **Serial Line:** Must be filled out when the line selection is set to direct connect (serial line).
 - ◇ **Baud Rate:** Specifies baud rate; must be 19200 for EMP to connect properly.
 - ◇ **COM Port No.:** Sets the COM port number to which the null modem serial cable is connected.
- ◆ **Connect:** Initiates connection to the server. When you click this button, you are prompted for the EMP password.
- ◆ **Config:** Displays the Phonebook dialog.
- ◆ **Cancel:** Exit the Connect dialog with no action taken.
- ◆ **Help:** Display dialog-level help information.

Power on/off the server remotely

Selecting Power On/Off from the Action Menu allows you to power the server on or off, with POST power-up options. It generates the Power on/off dialog.

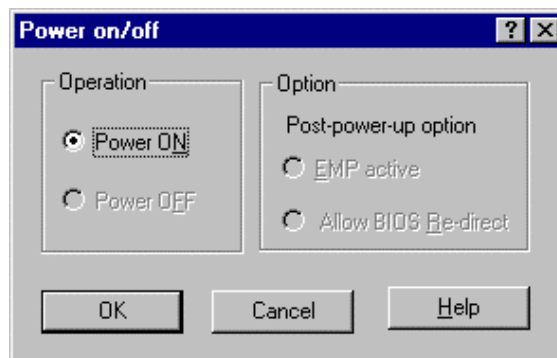

Power on/off dialog

Configuration and software utilities

Options available in the dialog are:

- ◆ **Power ON:** Powers on the server.
- ◆ **Power OFF:** Powers off the server. This option is not allowed if the server is configured in restricted mode for EMP operations.
- ◆ **Post-power-up option:** Sets the server mode EMP active or BIOS redirection. The setting is effective at the next power-up. The default selection is EMP active.
- ◆ **Cancel:** Exits the dialog with no action taken.
- ◆ **Help:** Displays dialog-level help information.
- ◆ **Reset the Server Remotely**

Selecting Reset from the Action Menu generates the Reset dialog so that you can remotely reset the server with POST reset options.

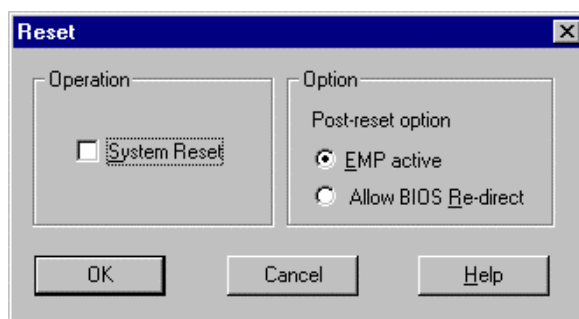

Reset dialog

Options available in the dialog are:

- ◆ **System Reset:** Resets the server with the selected POST reset options. This operation is not allowed if the server is configured in restricted mode for EMP operations.
- ◆ **Option Group:** Sets the POST reset option that will be effective after reset. The options are EMP active or BIOS redirection. The default selection is EMP active.
- ◆ **Cancel:** Exits the dialog with no action taken.
- ◆ **Help:** Displays dialog-level help information.

Phonebook

The EMP console provides a phonebook, a support plug-in that stores names and numbers of servers in a list that can be updated by adding, modifying, or deleting entries. You can open the phonebook from the Main Menu and tool bars, or launch it by clicking the Config button.

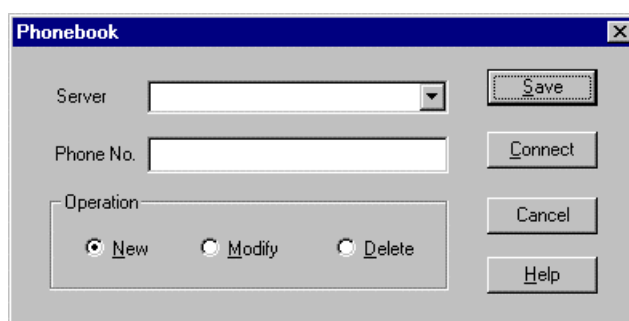

Phonebook dialog

Options available in the dialog are:

- ◆ **Server:** Displays a dropdown list of server names previously stored in the phonebook. If the New radio button is selected in the Operation area, the server area is cleared.
- ◆ **Phone No.:** Displays the number of the selected server. If the New radio button is selected in the Operation area, this area is cleared.
- ◆ **Operation**
 - ◇ **New:** Makes a new entry in the phonebook. Selecting this option clears the Server and Phone No. fields. You must click <Save> to add the entry to the phonebook.
 - ◇ **Modify:** Edits an existing entry. Before selecting this option, you must first select an existing entry from the Server dropdown edit box and modify the existing phone number. Click <Save> to store this entry in the phonebook.
 - ◇ **Delete:** Deletes an entry from the phonebook. You must first select an existing server from the Server dropdown edit box before selecting this option. Click <Save> to delete the entry.
- ◆ **Save:** Saves a new or modified phonebook entry or deletes an entry if you have already selected the Delete radio button.
- ◆ **Connect:** Raises the Connect dialog with the server from the phonebook's Server dropdown edit box already populating the Connect dialog's Server dropdown edit box.
- ◆ **Cancel:** Exits the dialog with no action taken.
- ◆ **Help:** Displays dialog-level help information.

Management plug-ins

System event log (SEL) viewer

The SEL viewer can display records in either hexadecimal or text (verbose) form. These options are available through the SEL viewer:

- ◆ View the SEL from a file
- ◆ Save the SEL to a file
- ◆ View SEL summary information
- ◆ View all SEL entries
- ◆ View SEL info by event type
- ◆ View SEL info by sensor type
- ◆ Set SEL display mode to either Hex or verbose mode
- ◆ Set the SEL output file format to either text or binary format
- ◆ Close the SEL viewer
- ◆ Exit the EMP console

SEL viewer menu options

The following menu options are available on the SEL viewer menu bar:

- ◆ File
 - ◇ **Open:** Allows you to view SEL data from a previously saved file if it was stored in binary format. Selecting the Open Menu item lets you specify a filename under which the data are found. The default filename is 'SELLOG.DAT'. If the file cannot be opened, the program displays an error message.
 - ◇ **Close:** Closes the SEL viewer.
 - ◇ **Save As:** Dumps the SEL data to a file in either binary raw or verbose text format. The binary file can be retrieved later. Selecting this option lets you specify a filename to which the data can be saved. The default filename is 'SELLOG.DAT'. If no data exist, an error message displays.
 - ◇ **Exit:** Exits the EMP console.
- ◆ Connect
- ◆ View
 - ◇ **SEL Information:** Displays SEL summary information.
 - ◇ **All Events:** Displays all events in the SEL.
 - ◇ **By Sensor Type:** Displays all events in the SEL generated by a specific sensor type, e.g., voltage, temperature, etc.
 - ◇ **By Event:** Displays all events in the SEL of a particular type, e.g., by memory or threshold. A pop-up menu lets you select the event type to display. This menu displays all event types that can be generated by the particular hardware.
 - ◇ **Settings:** Lets you change several operating parameters for the SEL viewer. This menu displays the following suboptions:
 - ◇ **Display HEX/Verbose:** Toggles between HEX mode and interpreted mode of displaying SEL records.
 - ◇ **Output Text/Binary:** Specifies whether SEL data will be saved to the file in binary format or verbose format.
- ◆ **Window:** Gives options for displaying currently open windows.
- ◆ **Help:** Provides version information for the SEL viewer and provides help topics on the EMP console.

Sensor data record (SDR) viewer

The SDR viewer lets you view the records retrieved from the SDR repository. Options available through the SDR viewer are:

- ◆ View all SDR records
- ◆ View SDR entries by SDR type
- ◆ View SDR summary information
- ◆ Set SDR display mode to either Hex or verbose mode
- ◆ Close the SDR viewer
- ◆ Exit the EMP console

SDR Viewer Menu Options

The SDR viewer menu bar contains the following:

- ◆ File
 - ◇ **Close:** Closes the SDR viewer.
 - ◇ **Exit:** Exits the EMP console.
- ◆ View
 - ◇ **Display all Records:** Displays all records from the SDR repository.
 - ◇ **SDR Type:** Displays the records of a particular SDR type. You select an SDR type from a pop-up menu that displays all the SDR types available for the given hardware.
 - ◇ **SDR Info:** Displays the SDR summary information.
- ◆ **Settings:** Lets you change operating parameters for the SDR viewer. This menu displays the following suboption:
 - ◇ **Display HEX/Verbose:** Toggles between HEX mode and interpreted mode of displaying SDR records.
- ◆ **Window:** Gives options for displaying currently open windows.
- ◆ **Help:** Provides version information for the SDR viewer and provides help topics on the EMP console.

Field replaceable unit (FRU) viewer

The FRU viewer lets you view data from the server's baseboard FRU information area. Options available with the FRU viewer are:

- ◆ View all FRU records
- ◆ View FRU summary information
- ◆ Set FRU display mode to either Hex or verbose mode
- ◆ Close the FRU viewer
- ◆ Exit the EMP console

FRU viewer menu options

The following menu options are on the FRU viewer menu bar:

- ◆ File
 - ◇ **Close:** Closes the FRU viewer.
 - ◇ **Exit:** Exits the EMP console.
- ◆ View
 - ◇ **Display all Records:** Displays all FRU data, which consist of chassis, board, and product information.
 - ◇ **FRU Info:** Displays the FRU summary information.
- ◆ **Settings:** Lets you change operating parameters for the FRU viewer. This menu displays the following suboption:
 - ◇ **Display HEX/Verbose:** Toggles between HEX mode and interpreted mode of displaying FRU records.
- ◆ **Window:** Gives options for displaying currently open windows.
- ◆ **Help:** Provides version information for the FRU viewer and provides help topics on the EMP console.

FRU and SDR load utility

The Field Replacement Unit (FRU) and Sensor Data Record (SDR) load utility is a DOS-based program used to update the server management subsystem's product level FRU, SDR, and the Desktop Management Interface (DMI) nonvolatile storage components (EEPROMs). The utility:

- ◆ Discovers the product configuration based on instructions in a master configuration file
- ◆ Displays the FRU information
- ◆ Updates the EEPROM associated with the Baseboard Management Controller (BMC) that holds the SDR and FRU area
- ◆ Updates the DMI FRU area located in the BIOS nonvolatile storage device
- ◆ Generically handles FRU devices that might not be associated with the BMC

When to run the FRU SDR load utility

You should run the FRUSDR load utility each time you upgrade or replace the hardware in your server, excluding add-in boards, hard drives, and RAM. For example, if you replace an array of fans, you need to run the utility. It programs the sensors that need to be monitored for server management.

Because the utility must be reloaded to properly initialise the sensors after programming, turn the server off and remove the AC power cords from the server. Wait approximately 30 seconds, then reconnect the power cords and turn on the server.

What you need to do

You can run the utility directly from the configuration software CD or from diskettes you create from the CD.

If you choose to run the FRUSDR Load Utility from a diskette, you must copy the utility from the CD and follow the instructions in the included README.TXT file.

If your diskette drive is disabled, or improperly configured, you must use BIOS Setup to enable it. If necessary, you can disable the drive after you are done with the FRUSDR utility.

How you use the FRU SDR load utility

The utility:

- ◆ Is compatible with ROM-DOS Ver. 6.22, MS-DOS Ver. 6.22, and later versions
- ◆ Accepts CFG, SDR, and FRU load files (the executable file for the utility is frusdr.exe)
- ◆ Requires the following supporting files
 - ◇ one or more .fru files describing the system's field replaceable units
 - ◇ a .cfg file describing the system configuration
 - ◇ an .sdr file describing the sensors in the system

Command line format

The basic command line format is

frusdr [-?] [-h] [-d {dmi, fru, sdr}] [-cfg *filename.cfg*] [-fru *filename.fru*]

Command	Description
Frusdr	Is the name of the utility
-? or -h	Displays usage information
-d {dmi, fru, sdr}	Displays requested area only
-cfg filename.cfg	Uses custom CFG file
-p	Pause between blocks of data
-v	Verbose, display any additional details

Parsing the command line

The FRUSDR load utility allows only one command line function at a time. A command line function can consist of two parameters. Example: -cfg filename.cfg. Invalid parameters cause an error message and exit the program. You can use either a slash (/) or a minus sign (-) to specify command line options. The -p and -v flags can be used in conjunction with any of the other options.

Displaying usage information

When the utility is run with the -? or -h command line flags, the following message is displayed when the verbose flag -v is added to the help command:

FRU & SDR Load Utility Version 2.1 Revision R.1.1

```

Usage:   Frusdr
        -? or -h           Displays usage information
        -d {dmi,fru,sdr}  Only displays requested area.
        -cfg filename.cfg Uses custom CFG file.
        -p                Pause between blocks of data.
        -v                Verbose, display any additional details.
    
```

Copyright (c) 1998, Intel Corporation, All Rights Reserved

This utility must be run from a system executing DOS. Running in a Window's DOS box is insufficient and will provide incorrect results. Programming the BMC FRU area clears the SDR table; therefore the SDR table must be reprogrammed. Upon completing the programming of the FRU and SDR areas, the server should be rebooted.

NOTE

DOS users may alternatively use a '/' instead of the '-'.

The following information displays if the -v option is included in the command line.

The /D FRU command may be followed with up to 16 device addresses. These device addresses are used to view up to 16 different FRU areas, instead of the default of displaying the BMC FRU. The arguments following the "-d FRU" are in the same order and value as the NVS_TYPE, NVS_LUN, DEV_BUS and DEV_ADDRESS which are found in the FRU file header in each FRU file. The LUN address is optional. If the LUN address is used, it must start with an 'L'.

Usage: FRUSDR -d fru (device) [lun] (bus) (addr) (addr2) (etc)

Example: FRUSDR /D FRU IMBDEVICE L00 00 C0 C2

The configuration file may be used to load multiple FRU and SDR files. In the configuration file, you may define which FRU and SDR areas are to be programmed. Additionally, you may request information from the user or ask the user to choose which areas to program.

Displaying a given area

When the utility is run with the `-d DMI`, `-d FRU`, or `-d SDR` command line flag, the indicated area is displayed. Each area represents one sensor for each instrumented device in the server. If the given display function fails because of an inability to parse the data present or a hardware failure, the utility displays an error message and exits.

Displaying DMI area

Each DMI area displayed is headed with the DMI area designated name. In each area, each field has a field name header followed by the field in ASCII or as a number.

Example:

To display the DMI area, type `frusdr -d dmi` and press <Enter>.

Displaying FRU area

The FRU area is displayed in ASCII format when the field is ASCII or as a number when the field is a number. Each FRU area displayed is headed with the FRU area designated name. Each field has a field name header followed by the field in ASCII or as a number. The board, chassis, and product FRU areas end with an END OF FIELDS CODE that indicates there are no more data in the area. The internal use area is displayed in hex format, 16 bytes per line.

Example:

To display the FRU area, type `frusdr -d fru` and press <Enter>.

Displaying SDR area

The SDR nonvolatile storage area is displayed in the following hex format. The data are separated by a sensor record number X header, where X is the number of that sensor record in the SDR area. The next line after the header is the sensor record data in hex format delineated by spaces. Each line holds up to 16 bytes. The data on each line are followed by the same data in ASCII format; nonprintable characters (ch < 32 || ch > 126) are substituted by a period (.).

Example:

To display the SDR area, type `frusdr -d sdr` and press <Enter>.

Using specified CFG file

The utility can be run with the command line parameter of `-cfg filename.cfg`. The filename can be any DOS-accepted, eight-character filename string. The utility loads the specified CFG file and uses the entries in that file to probe the hardware and to select the proper SDRs to load into nonvolatile storage.

Displaying utility title and version

The utility displays its title :

FRU & SDR Load Utility, Version 2.0, Revision X.XX where X.XX is the revision number for the utility.

Configuration file

The configuration file is in ASCII text. The utility executes commands formed by the strings present in the configuration file. These commands cause the utility to run tasks needed to load the proper SDRs into the nonvolatile storage of the BMC and possibly generic FRU devices. Some of the commands may be interactive and require you to make a choice.

Prompting for product level FRU information

Through the use of a configuration file, the utility might prompt you for FRU information.

Filtering records from the SDR file

The MASTER.SDR file has all the possible SDRs for the system. These records might need to be filtered based on the current product configuration. The configuration file directs the filtering of the SDRs.

Updating the SDR nonvolatile storage area

After the utility validates the header area of the supplied SDR file, it updates the SDR repository area. Before programming, the utility clears the SDR repository area. The utility filters all tagged SDRs depending on the product configuration set in the configuration file. Nontagged SDRs are automatically programmed. The utility also copies all written SDRs to the SDR.TMP file; it contains an image of what was loaded. The TMP file is also useful for debugging the server.

Updating FRU nonvolatile storage area

After the configuration is determined, the utility updates the FRU nonvolatile storage area. First it verifies the common header area and checksum from the specified FRU file. The internal use area is read out of the specified .FRU file and is programmed into the nonvolatile storage. The chassis area is read out of the specified .FRU file. Finally, it reads the product area out of the specified FRU file, then the area is programmed into the FRU nonvolatile storage. All areas are also written to the FRU.TMP file.

Updating DMI FRU nonvolatile storage area

After programming the BMC FRU area, the utility programs chassis, board, and product FRU information to the DMI fields, if the DMI flag follows each FRUAREA command in the configuration file.

Cleaning up and exiting

If an update was successfully performed, the utility displays a single message and then exits.

If the utility fails, it immediately exits with an error message and exit code.

Upgrading the BIOS

Preparing for the upgrade

Before you upgrade the BIOS, prepare for the upgrade by recording the current BIOS settings, obtaining the upgrade utility, and making a copy of the current BIOS.

Recording the current BIOS settings

1. Boot the computer and press <F2> when you see the message:

Press <F2> Key if you want to run SETUP

2. Write down the current settings in the BIOS Setup program.

CAUTION

Do not skip step 2. You will need these settings to configure your computer at the end of the procedure.

Obtaining the upgrade utility

You can upgrade to a new version of the BIOS using the new BIOS files and the BIOS upgrade utility, iFLASH.EXE. You can obtain the BIOS upgrade file and the iFLASH.EXE utility through your computer supplier or from the Intel World Wide Web site:

<http://www.intel.com>

NOTE

Please carefully read through all the instructions distributed with the upgrade utility before attempting any BIOS upgrade.

This upgrade utility lets you:

- ◆ Upgrade the BIOS in flash memory.
- ◆ Update the language section of the BIOS.

The following steps explain how to upgrade the BIOS.

Creating a bootable diskette

1. Use a DOS or Windows 95 system to create the diskette.
2. Insert a diskette in drive A.
3. At the C:\ prompt, for an unformatted diskette, type:

format a: /s

or, for a formatted diskette, type:

sys a:

4. Press <Enter>

Creating the BIOS upgrade diskette

The BIOS upgrade file is a compressed self-extracting archive that contains the files you need to upgrade the BIOS.

1. Copy the BIOS upgrade file to a temporary directory on your hard disk.
2. From the C:\ prompt, change to the temporary directory.
3. To extract the file, type the name of the BIOS upgrade file, for example:

10006BI1.EXE

4. Press <Enter>. The extracted file contains the following files:

LICENSE.TXT

README.TXT

BIOS.EXE

5. Read the LICENSE.TXT file, which contains the software license agreement, and the README.TXT file, which contains the instructions for the BIOS upgrade.
6. Insert the bootable diskette into drive A.
7. To extract the BIOS.EXE file to the diskette, change to the temporary directory that holds the BIOS.EXE file and type:

BIOS A:

8. Press <Enter>.
9. The diskette now holds the BIOS upgrade and recovery files.

Upgrading the BIOS

1. Boot the computer with the diskette in drive A. The BIOS upgrade utility screen appears.
2. Select Update Flash Memory From a File.
3. Select Update System BIOS. Press <Enter>.
4. Use the arrow keys to select the correct .bio file. Press <Enter>.

5. When the utility asks for confirmation that you want to flash the new BIOS into memory, select Continue with Programming. Press <Enter>.
6. When the utility displays the message upgrade is complete, remove the diskette. Press <Enter>.
7. As the computer boots, check the BIOS identifier (version number) to make sure the upgrade was successful.
8. To enter the Setup program, press <F2> when you see the message:
Press <F2> Key if you want to run SETUP
9. For proper operation, load the Setup program defaults. To load the defaults, press <F9>.
10. To accept the defaults, press <Enter>.
11. Set the options in the Setup program to the settings you wrote down before the BIOS upgrade.
12. To save the settings, press <F10>.
13. To accept the settings, press <Enter>.
14. Turn off the computer and reboot.

Recovering the BIOS

It is unlikely that anything will interrupt the BIOS upgrade; however, if an interruption occurs, the BIOS could be damaged. In that case, you must recover the BIOS.

NOTE

Because of the small amount of code available in the nonerasable boot block area, there is no video support. You will not see anything on the screen during the procedure. Monitor the procedure by listening to the speaker and looking at the diskette drive LED.

The procedure for recovering the BIOS is detailed in the 'Mainboard' chapter. After doing the procedure, leave the upgrade disk in drive A and turn on the server, then continue with the BIOS upgrade.

Changing the BIOS language

You can use the BIOS upgrade utility to change the language BIOS displays. Use a bootable diskette containing the Intel flash utility and language files.

1. Boot the computer with the bootable diskette in drive A. The BIOS upgrade utility screen appears.
2. Select Update Flash Memory From a File.
3. Select Update Language Set. Press <Enter>.
4. Select drive A and use the arrow keys to select the correct .lng file. Press <Enter>.
5. When the utility asks for confirmation that you want to flash the new language into memory, select Continue with Programming. Press <Enter>.
6. When the utility displays the message upgrade is complete, remove the diskette. Press <Enter>.
7. The computer will reboot and the changes will take effect.

Using the firmware update utility

The Firmware Update Utility is a DOS-based program used to update the BMC's firmware code. You need to run the utility only if new firmware code is necessary.

Running the firmware update utility

1. Create a DOS-bootable diskette. The version of DOS must be 6.0 or higher.
2. Place the firmware update utility (FWUPDATE.EXE) and the *.hex file on the diskette. Make a note of the *.hex file name, because you will need it later.
3. Insert the diskette into the drive and boot to it.
4. At the DOS prompt, run the executable file (FWUPDATE.EXE).
5. The utility will display a menu screen. Select 'Upload Flash'.
6. The utility will ask for a file name. Enter the name of the *.hex file.
7. The program will load the file and then ask if it should upload boot block. Press 'N' to continue.
8. The program will next ask if it should upload operational code. Press 'Y' to continue.
9. Once the operational code has been updated and verified, press any key to continue. Then press <ESC> to exit the program.
10. Shut the system down and remove any diskettes in the system.
11. Disconnect all AC power cords from the system and wait 60 seconds.
12. Reconnect the AC power cords and power up the system.

Installing video drivers

After configuring the system, you need to install video drivers to take full advantage of the features of the onboard CL-GD5480 super VGA video controller.

- ◆ The configuration software CD includes video drivers for use with DOS and Windows NT. Check the 'README.TXT' file on the CD for information on installing these drivers.
- ◆ For other operating systems, see your OS instructions for installing device drivers.

Using the Symbios SCSI utility

The Symbios SCSI utility detects the SCSI host adapters on the system board. Use the utility to:

- ◆ Change default values
- ◆ Check and/or change SCSI device settings that may conflict with those of other devices in the server

Running the SCSI utility

When this message appears on the video monitor:

Press Ctrl-C to run SCSI Utility...

Press <Ctrl+C> to run the utility. When it appears, choose the host adapter that you want to configure.

8 SOLVING PROBLEMS

This chapter helps you identify and solve problems that might occur while you are using the system.

Resetting the system

<i>To do this:</i>	<i>Press:</i>
Soft boot reset, which clears system memory and reloads the operating system.	<Ctrl+Alt+Del>
Clear system memory, restart POST, and reload the operating system.	Reset button
Cold boot reset, which clears system memory, restarts POST, reloads the operating system, and halts power to all peripherals.	Power off/on

Initial system startup

Problems that occur at initial system startup are usually caused by incorrect installation or configuration. Hardware failure is a less frequent cause.

Checklist

- ◆ Are all cables correctly connected and secured?
- ◆ Are the processors fully seated in their slots on the baseboard?
- ◆ Are all add-in ISA and PCI boards fully seated in their slots on the baseboard?
- ◆ Are all switch and jumper settings on the baseboard correct?
- ◆ Are all jumper and switch settings on add-in boards and peripheral devices correct?
 - To check these settings, refer to the manufacturer's documentation that comes with them. If applicable, ensure that there are no conflicts—for example, two add-in boards sharing the same interrupt.
- ◆ Are all DIMMs installed correctly?
- ◆ Are all peripheral devices installed correctly?
- ◆ If the system has a hard disk drive, is it properly formatted or configured?
- ◆ Are all device drivers properly installed?
- ◆ Are the configuration settings made with the SSU correct?
- ◆ Is the operating system properly loaded? Refer to the operating system documentation.
- ◆ Did you press the system power on/off switch on the front panel to turn the server on (power-on light should be lit)?
- ◆ Are the system power cords properly connected to the system and plugged into an outlet for 100-120 VAC or 200-240 VAC?
- ◆ Is AC power available at the wall outlet?
- ◆ If these items are correct but the problem recurs, see 'More problem solving procedures' on page 3 of this chapter.

Running new application software

Problems that occur when you run new application software are usually related to the software. Faulty equipment is much less likely, especially if other software runs correctly.

Checklist

- ◆ Does the system meet the minimum hardware requirements for the software? See the software documentation.
- ◆ Is the software an authorized copy? If not, get one; unauthorized copies often do not work.
- ◆ If you are running the software from a diskette, is it a good copy?
- ◆ If you are running the software from a CD-ROM disk, is the disk scratched or dirty?
- ◆ If you are running the software from a hard disk drive, is the software correctly installed?
 - Were all necessary procedures followed and files installed?
- ◆ Are the correct device drivers installed?
- ◆ Is the software correctly configured for the system?
- ◆ Are you using the software correctly?
- ◆ If the problems persist, contact the software vendor's customer service representative.

After the system has been running correctly

Problems that occur after the system hardware and software have been running correctly often indicate equipment failure. Many situations that are easy to correct, however, can also cause such problems; sometimes the problem stems from changes made to the system, such as hardware or software that has been added or removed.

Checklist

- ◆ If you are running the software from a diskette, try a new copy of the software.
- ◆ If you are running the software from a CD-ROM disk, try a different disk to see if the problem occurs on all disks.
- ◆ If you are running the software from a hard disk drive, try running it from a diskette. If the software runs correctly, there may be a problem with the copy on the hard disk drive. Reinstall the software on the hard disk, and try running it again. Make sure all necessary files are installed.
- ◆ If the problems are intermittent, there may be a loose cable, dirt in the keyboard (if keyboard input is incorrect), a marginal power supply, or other random component failures.
- ◆ If you suspect that a transient voltage spike, power outage, or brownout might have occurred, reload the software and try running it again. (Symptoms of voltage spikes include a flickering video display, unexpected system reboots, and the system not responding to user commands.)

NOTE

Random errors in data files: if you are getting random errors in your data files, they may be getting corrupted by voltage spikes on your power line. If you are experiencing any of the above symptoms that might indicate voltage spikes on the power line, you may want to install a surge suppresser between the power outlet and the system power cords.

More problem-solving procedures

This section provides a more detailed approach to identifying a problem and locating its source.

Preparing the system for diagnostic testing

CAUTION

Turn off devices before disconnecting cables: before disconnecting any peripheral cables from the system, turn off the system and any external peripheral devices. Failure to do so can cause permanent damage to the system and/or the peripheral devices.

1. Turn off the system and all external peripheral devices. Disconnect all of them from the system, except the keyboard and video monitor.
2. Make sure the system power cords are plugged into a properly grounded AC outlet.
3. Make sure your video display monitor and keyboard are correctly connected to the system. Turn on the video monitor. Set its brightness and contrast controls to at least two-thirds of their maximum ranges (see the documentation supplied with your video display monitor).
4. If the operating system normally loads from the hard disk drive, make sure there is no diskette in drive A. Otherwise, place a diskette containing the operating system files in drive A.
5. Turn on the system. If the power LED does not light, see “Power Light Does Not Light” on page 4 of this chapter.

Using PCDiagnosics

A diagnostics package for the system is contained on the configuration software CD that comes with the system. For documentation about the test modules, see the Diagnostic help disks that end with the extension .HLP. They are ASCII files that you can print to form a manual of all tests in this product.

- ◇ The program called Testview uses a simple DOS-based menu system.
- ◇ The program called T.EXE is not for Windows or DOS; you can access it at the command line prompt without having a hard drive installed.
- ◇ The README.TXT file for diagnostics tells how to install the program.

CAUTION

Read help information for a test before running it: the diagnostic package contains many optional tests that should be used only by a user with advanced technical knowledge. Inadvertent actions could be damaging, such as running a hard drive write test on a hard disk. All tests that require external hardware, user interaction, or are destructive, are disabled in the default configurations. Before using such a test, make sure you read and understand the help information for that test.

Monitoring POST

See the ‘Configuration’ chapter.

Verifying proper operation of key system lights

As POST determines the system configuration, it tests for the presence of each mass storage device installed in the system. As each device is checked, its activity light should turn on briefly. Check for the following:

- ◆ Does the diskette drive activity light turn on briefly? If not, see ‘Diskette drive activity light does not light’ on page 6 of this chapter.

Solving problems

- ◆ If a second diskette drive is installed, does its activity light turn on briefly? If not, see 'Diskette drive activity light does not light' on page 6 of this chapter.
- ◆ If there is a hard disk drive or SCSI devices installed in the system, does the hard disk drive activity light on the control panel turn on briefly? If not, see 'Hard disk drive activity light does not light' on page 6 of this chapter.

Confirming loading of the operating system

Once the system boots up, the operating system prompt appears on the screen. The prompt varies according to the operating system. If the operating system prompt does not appear, see 'Initial system startup on page 1 of this chapter.

Specific problems and corrective actions

This section provides possible solutions for these specific problems:

- ◇ Power light does not light.
- ◇ No beep or incorrect beep pattern.
- ◇ No characters appear on screen.
- ◇ Characters on the screen appear distorted or incorrect.
- ◇ System cooling fans do not rotate.
- ◇ Diskette drive activity light does not light.
- ◇ Hard disk drive activity light does not light.
- ◇ CD-ROM drive activity light does not light.
- ◇ Problems with application software.
- ◇ The startup prompt "Press <F2> key if you want to run Setup" does not appear on the screen.
- ◇ The bootable CD-ROM is not detected.

Try the solutions in the order given. If you cannot correct the problem, contact your service representative or authorised dealer for assistance.

Power light does not light

Check the following:

- ◆ Are all the power supplies plugged in? Is the power turned on to the power strip or outlet? Do you have they blown a fuse or breaker?
- ◆ Is the system operating normally? If so, the power LED is probably defective or the cable from the front panel to the baseboard is loose.
- ◆ Are there other problems with the system? If so, check the items listed under "System Cooling Fans Do Not Rotate Properly."

If all items are correct and problems persist, contact your service representative or authorised dealer for assistance.

No beep codes

If the system operates normally, but there was no beep, the speaker may be defective. If the speaker is enabled, but the speaker does not function, contact your service representative or authorised dealer for assistance.

Record the beep code emitted by POST, and see 'Error and informational messages' which start on page 7 of this chapter.

No characters appear on screen

Check the following:

- ◆ Is the keyboard working? Check to see that the “Num Lock” light is functioning.
- ◆ Is the video monitor plugged in and turned on? Many modern video monitors shut down when inactive and may require a moment to warm up when activated.
- ◆ Are the brightness and contrast controls on the video monitor properly adjusted?
- ◆ Are the video monitor switch settings correct?
- ◆ Is the video monitor signal cable properly installed?
- ◆ Is the onboard video controller enabled?

If you are using an add-in video controller board, do the following:

1. Verify that the video controller board is fully seated in the baseboard connector (and verify that the video monitor is plugged in to the ACTIVE video controller).
2. Reboot the system for changes to take effect.
3. If there are still no characters on the screen after you reboot the system and POST emits a beep code, write down the beep code you hear. This information is useful for your service representative. See ‘Error and informational messages’ which start on page 7 of this chapter.
4. If you do not receive a beep code and characters do not appear, the video display monitor or video controller may have failed. You can verify this by trying the monitor on another system or trying a different monitor on this system. Contact your service representative or authorized dealer for assistance.

Characters are distorted or incorrect

Check the following:

- ◆ Are the brightness and contrast controls properly adjusted on the video monitor? See the manufacturer’s documentation.
- ◆ Are the video monitor signal and power cables properly installed?
- ◆ Is the correct monitor/video board installed for your operating system?

If the problem persists, the video monitor may be faulty or it may be the incorrect type. Contact your service representative or authorised dealer for assistance.

System cooling fans do not rotate properly

If the system cooling fans are not operating properly, system components could be damaged.

Check the following:

- ◆ Is AC power available at the wall outlet?
- ◆ Are the system power cords properly connected to the system and the wall outlet?
- ◆ Did you press the power on/off push-button switch?
- ◆ Is the power-on light lit?
- ◆ Have any of the fan motors stopped (use the server management subsystem to check the fan status)?
- ◆ Are the fan power connectors properly connected to the baseboard?
- ◆ Is the cable from the front panel board connected to the baseboard?
- ◆ Are the power supply cables properly connected to the baseboard?
- ◆ Are there any shorted wires caused by pinched cables or power connector plugs forced into power connector sockets the wrong way?

If the switches and connections are correct and AC power is available at the wall outlet, contact your service representative or authorised dealer for assistance.

Diskette drive activity light does not light

Check the following:

- ◆ Are the diskette drive power and signal cables properly installed?
- ◆ Are all relevant switches and jumpers on the diskette drive set correctly?
- ◆ Is the diskette drive properly configured?
- ◆ Is the diskette drive activity light always on? If so, the signal cable may be plugged in incorrectly.

If you are using the onboard diskette controller, use the SSU to make sure that “Onboard Floppy” is set to “Enabled.” If you are using an add-in diskette controller, make sure that “Onboard Floppy” is set to “Disabled.” To run the SSU, see the detailed information in the ‘Configuration’ chapter.

If the problem persists, there may be a problem with the diskette drive, baseboard, or drive signal cable. Contact your service representative or authorised dealer for assistance.

Hard disk drive activity light does not light

If you have installed one or more hard disk drives in your system, check the following:

- ◆ Are the power and signal cables to the drive properly installed?
- ◆ Are all relevant switches and jumpers on the hard drive and adapter board set correctly?
- ◆ Is the onboard IDE controller enabled? (IDE hard drives only)
- ◆ Is the hard disk drive properly configured?

NOTE

Front panel hard disk LED indicates IDE and SCSI devices: the hard disk drive activity light on the front panel lights when either an IDE hard disk drive, or a SCSI device controlled by the onboard SCSI host controller, is in use. This LED does not display CD-ROM activity.

CD-ROM drive activity light does not light

Check the following:

- ◆ Are the power and signal cables to the CD-ROM drive properly installed?
- ◆ Are all relevant switches and jumpers on the drive set correctly?
- ◆ Is the drive properly configured?
- ◆ Is the onboard IDE controller enabled?

Network problems

If you have network problems, consult the documentation that came with the network board you purchased for this server.

PCI installation tips

Some common PCI tips are listed here.

- ◆ Reserve interrupts (IRQs) and/or memory addresses specifically for ISA adapters. This prevents PCI boards from trying to use the same settings ISA boards are using. Use the SSU to keep track of ISA adapter resources.
- ◆ Certain drivers may require interrupts that are not shared with other PCI drivers. The SSU can be used to adjust the interrupt numbers for PCI devices. For certain drivers, it may be necessary to alter settings so that interrupts are not shared.
- ◆ Check PCI interrupt interdependencies among slots and onboard devices.

Problems with application software

If you have problems with application software, do the following:

- ◆ Verify that the software is properly configured for the system. See the software installation and operation documentation for instructions on setting up and using the software.
- ◆ Try a different copy of the software to see if the problem is with the copy you are using.
- ◆ Make sure all cables are installed correctly.
- ◆ Verify that the mainboard jumpers are set correctly. See the 'Mainboard' chapter.

If other software runs correctly on the system, contact your vendor about the failing software.

If the problem persists, contact the software vendor's customer service representative for assistance.

Bootable CD-ROM is not detected

Check the following:

- ◆ Is the BIOS set to allow the CD-ROM to be the first bootable device?

Error and informational messages

When you turn on the system, POST displays messages that provide information about the system. If a failure occurs, POST emits beep codes that indicate errors in hardware, software, or firmware. If POST can display a message on the video display screen, it causes the speaker to beep twice as the message appears.

POST codes and countdown codes

The BIOS indicates the current testing phase during POST after the video adapter has been successfully initialised by outputting a 2-digit hex code to I/O location 80h. If a port-80h ISA POST board is installed, it displays the 2-digit code on a pair of hex display LEDs.

Port-80 codes

<i>Normal Port 80 Codes</i>	<i>Beeps</i>	<i>Error</i>
02		Verify Real Mode
04		Get processor type
06		Initialize system hardware
08		Initialize chipset registers with initial POST values
09		Set in POST flag
0A		Initialize processor registers
0B		Enable processor cache
0C		Initialize caches to initial POST values
0E		Initialize I/O
0F		Initialize the local bus IDE
10		Initialize Power Management
11		Load alternate registers with initial POST valuesnew
12		Restore processor control word during warm boot
14		Initialize keyboard controller
16	1-2-2-3	BIOS ROM checksum
18		8254 timer initialization
1A		8237 DMA controller initialization

Solving problems

Normal Port 80 Codes	Beeps	Error
1C		Reset Programmable Interrupt Controller
20	1-3-1-1	Test DRAM refresh
22	1-3-1-3	Test 8742 Keyboard Controller
24		Set ES segment register to 4GB
28	1-3-3-1	Autosize DRAM
2A		Clear 512K base RAM
2C	1-3-4-1	RAM failure on address line xxxx*
2E	1-3-4-3	RAM failure on data bits xxxx* of low byte of memory bus
30	1-4-1-1	RAM failure on data bits xxxx* of high byte of memory bus
32		Test processor bus-clock frequency
34		Test CMOS
35		RAM Initialize alternate chipset registers
36		Warm start shut down
37		Reinitialize the chipset (MB only)
38		Shadow system BIOS ROM
39		Reinitialize the cache (MB only)
3A		Autosize cache
3C		Configure advanced chipset registers
3D		Load alternate registers with CMOS valuesnew
40		Set Initial processor speed new
42		Initialize interrupt vectors
44		Initialize BIOS interrupts
46	2-1-2-3	Check ROM copyright notice
47		Initialize manager for PCI Option ROMs
48		Check video configuration against CMOS
49		Initialize PCI bus and devices
4A		Initialize all video adapters in system
4B		Display QuietBoot screen
4C		Shadow video BIOS ROM
4E		Display copyright notice
50		Display processor type and speed
51		Initialize EISA board
52		Test keyboard
54		Set key click if enabled
56		Enable keyboard
58	2-2-3-1	Test for unexpected interrupts
5A		Display prompt "Press F2 to enter SETUP"
5C		Test RAM between 512 and 640k
60		Test extended memory
62		Test extended memory address lines
64		Jump to UserPatch1
66		Configure advanced cache registers

Normal Port 80 Codes	Beeps	Error
68		Enable external and processor caches
6A		Display external cache size
6C		Display shadow message
6E		Display non-disposable segments
70		Display error messages
72		Check for configuration errors
74		Test real-time clock
76		Check for keyboard errors
7A		Test for key lock on
74		Test real-time clock
76		Check for keyboard errors
7A		Test for key lock on
7C		Set up hardware interrupt vectors
7E		Test coprocessor if present
80		Detect and install external RS232 ports
82		Detect and install external parallel ports
85		Initialize PC-compatible PnP ISA devices
86		Re-initialize on board I/O ports
88		Initialize BIOS Data Area
8A		Initialize Extended BIOS Data Area
8C		Initialize floppy controller
90		Initialize hard disk controller
91		Initialize local bus hard disk controller
92		Jump to UserPatch2
93		Build MPTABLE for multi-processor boards
94		Disable A20 address line
95		Install CD-ROM for boot
96		Clear huge ES segment register
98	1-2	Search for option ROMs. One long, two short beeps on checksum failure
9A		Shadow option ROMs
9C		Set up Power Management
9E		Enable hardware interrupts
A0		Set time of day
A2		Check key lock
A4		Initialize typematic rate
A8		Erase F2 prompt
AA		Scan for F2 key stroke
AC		Enter SETUP
AE		Clear in-POST flag
B0		Check for errors
B2		POST done – prepare to boot Operating System
B4	1	One short beep before boot

Solving problems

Normal Port 80 Codes	Beeps	Error
B5		Display MultiBoot menu
B6		Check password (optional)
B8		Clear global descriptor table
BC		Clear parity checkers
BE		Clear screen (optional)
BF		Check virus and backup reminders
C0		Try to boot with INT 19
DO		Interrupt handler error
D4		Pending interrupt error
D6		Initialize option ROM error
D8		Shutdown error
DA		Extended Block Move
DC		Shutdown 10 error

POST error codes and messages

The following error codes and messages are representative of various conditions BIOS identifies. The exact strings and error numbers may be different from those listed here.

Code	Error message
0162	BIOS unable to apply BIOS update to processor 1
0163	BIOS unable to apply BIOS update to processor 2
0164	BIOS does not support current stepping for processor 1
0165	BIOS does not support current stepping for processor 2
0200	Failure Fixed Disk
0210	Stuck Key
0211	Keyboard error
0212	Keyboard Controller Failed
0213	Keyboard locked - Unlock key switch
0220	Monitor type does not match CMOS - Run SETUP
0230	System RAM Failed at offset
0231	Shadow RAM Failed at offset
0232	Extended RAM Failed at offset
0250	System battery is dead - Replace and run SETUP
0251	System CMOS checksum bad - Default configuration used
0260	System timer error
0270	Real-time clock error
0297	ECC Memory error in base (extended) memory test in Bank xx
02B2	Incorrect Drive A type - run SETUP
02B3	Incorrect Drive B type - run SETUP
02D0	System cache error - Cache disabled
02F5	DMA Test Failed
02F6	Software NMI Failed
0401	Invalid System Configuration Data - run configuration utility

Code	Error message
None	System Configuration Data Read Error
0403	Resource Conflict
0404	Resource Conflict
0405	Expansion ROM not initialized
0406	Warning: IRQ not configured
0504	Resource Conflict
0505	Expansion ROM not initialized
0506	Warning: IRQ not configured
0601	Device configuration changed
0602	Configuration error - device disabled
8100	Processor 0 failed BIST
8101	Processor 1 failed BIST
8104	Processor 0 Internal Error (IERR) failure
8105	Processor 1 Internal Error (IERR) failure
8106	Processor 0 Thermal Trip failure
8107	Processor 1 Thermal Trip failure
8108	Watchdog Timer failed on last boot, BSP switched
810A	Processor 1 failed initialization on last boot
810B	Processor 0 failed initialization on last boot
810C	Processor 0 disabled, system in uniprocessor mode
810D	Processor 1 disabled, system in uniprocessor mode
810E	Processor 0 failed FRB Level 3 timer
810F	Processor 1 failed FRB Level 3 timer
8110	Server Management Interface failed to function
8120	IOP subsystem is not functional
8150	NVRAM Cleared by Jumper
8151	NVRAM Checksum Error, NVRAM cleared
8152	NVRAM Data Invalid, NVRAM cleared

APPENDIX: RACK MOUNTING THE FT5000

Safety Guidelines

Read through all the safety information and the rack mounting instructions before you start.

Before you remove any cover

Before removing any cover at any time to work inside the system, you should follow these safety guidelines.

1. Turn off and disconnect **all** peripheral devices connected to the system.
2. Turn off the system by using the push-button on/off power switch on the front of the system.
3. Unplug the AC power cords from the system or wall outlet.
4. Use full antistatic precautions as given in the *Safety & Regulatory Notices* at the front of the Owner's Handbook.

Tools and supplies needed

- ◆ Phillips (cross-head) screwdriver (#1 and #2 bit).
- ◆ Antistatic wrist strap and conductive foam pad (recommended).
- ◆ Lifting or mechanical handling equipment capable of supporting the maximum configured weight of the server, (approximately 45 Kg).

Warnings and cautions

These warnings and cautions apply whenever you carry out any work on the system or its component parts. Only an authorised engineer or other suitably qualified technical person should attempt to integrate and configure the system.

- ◆ **System power on/off:** The on/off button on the front panel DOES NOT turn off the system AC power. To remove all power from the system, you must unplug the AC power cords from the wall outlet or the system.
- ◆ **Hazardous conditions, power supply:** Hazardous voltage, current, and energy levels are present inside the power supply. There are no user-serviceable parts inside it.
- ◆ **ESD and handling boards:** Always handle boards carefully. They can be extremely sensitive to ESD. Hold boards only by their edges. Do not remove boards from their protective wrapper until you are ready to put it straight into the system.
- ◆ **Cooling and airflow:** For proper cooling and airflow, always install the chassis access cover before turning on the system. Operating it without the cover in place may damage system components.
- ◆ **Avoid personal injury:** To avoid personal injury when unpacking the server, use a mechanical assist unit to lift it off the shipping pallet. The minimum server configuration weighs 38 kg; the maximum weighs 45 kg.
 - ◇ Do not attempt to lift or move the server by the handles on the power supplies.
 - ◇ Use a hand-truck or other mechanical assist unit to move the server from one location to another, or to raise it into position for rack mounting.

Additional precautions for the equipment rack

Use only the rack mounting assemblies that have been designed and tested for the FT5000 server. Other mountings may be unstable or unable to withstand the server weight when it is extended from the normal position for maintenance.

WARNING

Mitsubishi Electric PC Division accepts no responsibility for any damage or injury resulting from the improper installation of rack-mountable components into rack units.

Important points to note:

Anchor the equipment rack: The equipment rack must be anchored to a non-movable support to prevent it from falling over should one or more servers be extended in front of it on their slide assemblies. The anchors must be able to withstand a force of up to 113 kg. You must also consider the weight of any other device installed in the rack.

Main AC power disconnect: You are responsible for installing an AC power disconnect for the entire rack unit. This main disconnect must be readily accessible, and it must be labelled as controlling power to the entire unit, not just to the server(s).

Grounding the rack installation: To avoid the potential for an electrical shock hazard, you must include a third wire safety grounding conductor with the rack installation. If server power cords are plugged into AC outlets that are part of the rack, then you must provide proper grounding for the rack itself. If server power cords are plugged into wall AC outlets, the safety grounding conductor in each power cord provides proper grounding only for the server. You must provide additional, proper grounding for the rack and other devices installed in it.

Over-current protection: The server is designed for an AC line voltage source with up to 20 amperes of over-current protection. If the power system for the equipment rack is installed on a branch circuit with more than 20 amperes of protection, you must provide supplemental protection for the server. If more than one server is installed in the rack, the power source for each server must be from a separate branch circuit. The overall current rating of a server configured with three power supplies is under 12 amps.

CAUTION

If the rack unit is provided with any power distribution control circuitry, ensure that the circuits are not overloaded. It is also important that you do not overload the main AC outlet that provides power to the rack.

Temperature: The operating temperature of the server, when installed in an equipment rack, must not go below 5°C or rise above 35°C. Extreme fluctuations in temperature can cause a variety of problems or permanent damage within your server.

Ventilation: The equipment rack must provide sufficient airflow to the front of the server to maintain proper cooling. It must also include ventilation sufficient to exhaust approximately 1200W of heat per hour for the server. The rack selected and the ventilation provided must be suitable to the environment in which the server will be used.

Changing from pedestal to rack

Your FT5000 server may be initially supplied as a pedestal mounting unit and at some future time you may wish to change that to a rack mounting.

To change your server from pedestal mode to rack mode, you must complete two basic steps: removing the components of the pedestal mount, then configuring the server for a rack mount.

- ◆ Fitting rack mount kit is described in the next section, this part covers only a few details unique to the task of preparing a pedestal mount server for rack mounting. Turn to the next section if your server is already prepared.

Remove the covers

1. Read through the 'Safety guidelines' at the front of this chapter.
2. Turn off all peripheral devices connected to the server.
3. Turn the server power off with the on/off power switch on the front of the server AND unplug all AC power cords.
4. Label and disconnect all peripheral cables attached to the I/O panel on the back of the server.
5. Remove and save the single screw from the back of the *top* cover.

NOTE

There is no requirement to remove the access cover. This should remain in place as part of the system security measures.

6. Place the fingertips of your hand under the built-in handle on the back of the cover.
7. Using an even pull, slide the cover backward, about an inch, until it stops.

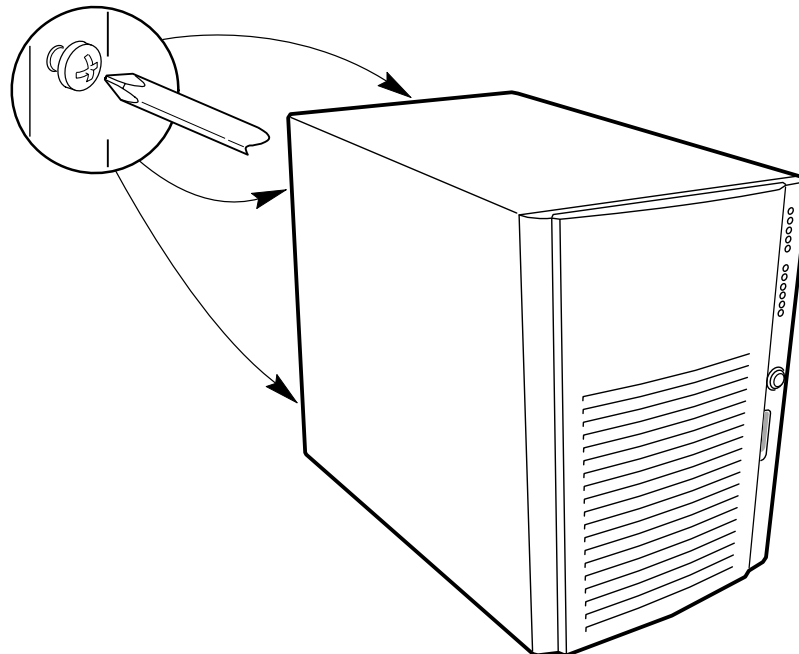

8. Pull the entire cover upward, straight away from the chassis, to disengage the rows of tabs from the notches in the chassis. Set the cover aside.
9. Remove and save the two screws from the back of the *left side* cover.
10. Remove the side cover in the same manner as the top cover, pull the cover back using the built-in handle, then lift it away.

Rack mounting the FT5000

11. Use a mechanical assist unit to carefully turn the server onto its left side and remove the pedestal mountings, as shown in the illustration; each one is held by a single screw.

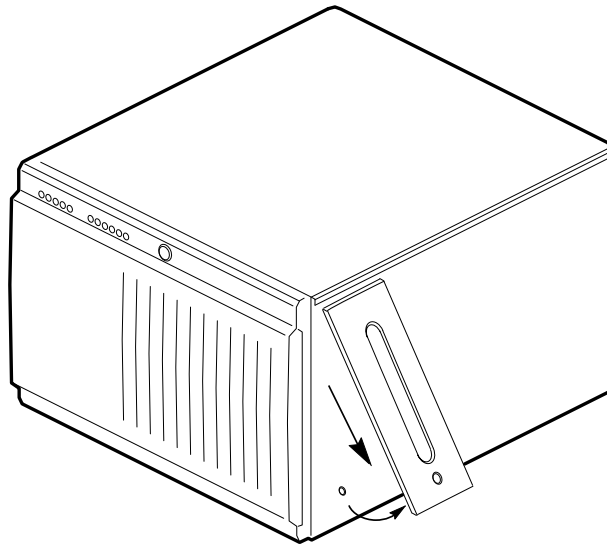

12. Follow the detailed instructions given on the next pages to fit the rails and install the server into the equipment rack.

Prepare the slide assemblies

1. Remove the slide assemblies from the kit.
2. Orient a slide assembly so that the smallest outer bar is facing down.
3. Fully extend the telescoping slide assembly until the centre bar hits the safety latch on the small outer bar (all three overlapping bars will be visible).

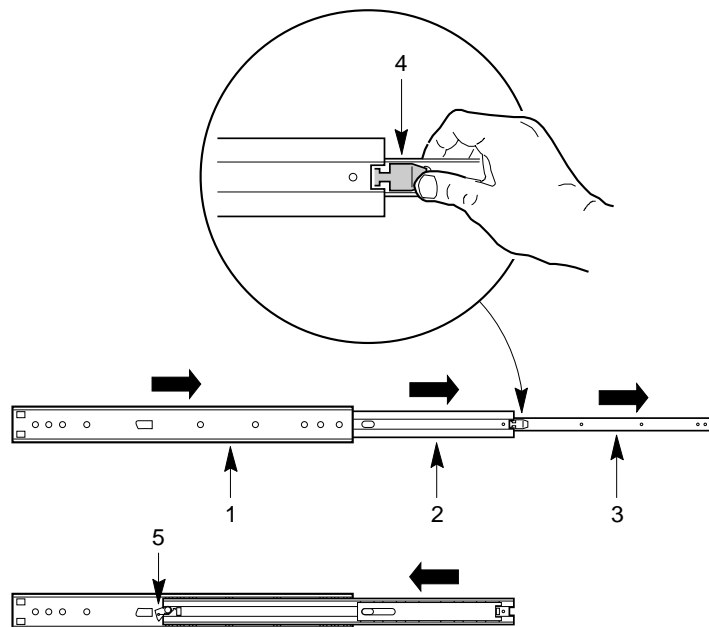

- 1 Large outer bar
- 2 Centre bar
- 3 Small inner bar
- 4 Safety latch on the centre bar
- 5 Safety latch on the small inner bar

4. Grasp the small outer bar with your right hand so that your thumb is on the safety latch of the small outer bar.
5. Press and hold the safety latch down, and at the same time, grasp the large outer bar with your left hand.
6. Pull the small bar out of the centre bar; this takes a little force to separate them. Set the small bar aside to attach to the chassis in a later step.
7. Orient the centre bar and large outer bar assembly so that the centre bar is facing up.
8. Grasp the centre bar with your right hand and the large outer bar with your left hand so that your left-hand thumb is on the safety latch of the centre bar.
9. Press the safety latch, and slide the bars together. Set the centre bar and large outer bar assembly aside to attach to the equipment rack in a later step.
10. Prepare the other slide assembly by repeating steps 2–9 above.

Prepare the server

Before you can install the FT5000 in the 19-inch equipment rack, you must install a bezel, handles and the small bars of the slide assemblies onto the sides of the server.

Attaching the bezel frame and door

To be installed in a rack, the server needs a bezel frame with rectangular cutouts where the chassis handles fit.

1. Attach the bezel frame by inserting the tabs at the corner of the frame into their corresponding rectangular slots on the chassis.
2. Attach the bezel door: with the door all the way open (down, as the server lay as it would when inserted in a rack), align the tabs on the door with their corresponding hinge loops on the chassis; slide the door to the right to engage the tabs in the loops.

Attach the chassis handles

Before you can attach the chassis handles, the server must be on its side, in the horizontal position in which you will slide it into the rack. If the server is not already in the proper position, you must move it. See step one, below.

1. If the server is not already in the proper position, then face the front of the server and, with the help of a mechanical assist unit, carefully tip it onto its left side, (the front-panel LEDs should now be at the top left and the hard drive bays at the bottom right of the front panel).
 - ◇ The bezel frame has rectangular cutouts on its edges where the chassis handles fit; you should be able to see two threaded holes in that cut-out space where the handles attach to the chassis.
2. Orient each handle so the two screw holes on the long edge of each handle align with the threaded holes in the chassis. Because the bezel frame's cutouts act as guides, the handles can be installed in only one way.
3. Use four screws from the kit to attach the handles to the chassis.

Attach the small bar of the slide to the server

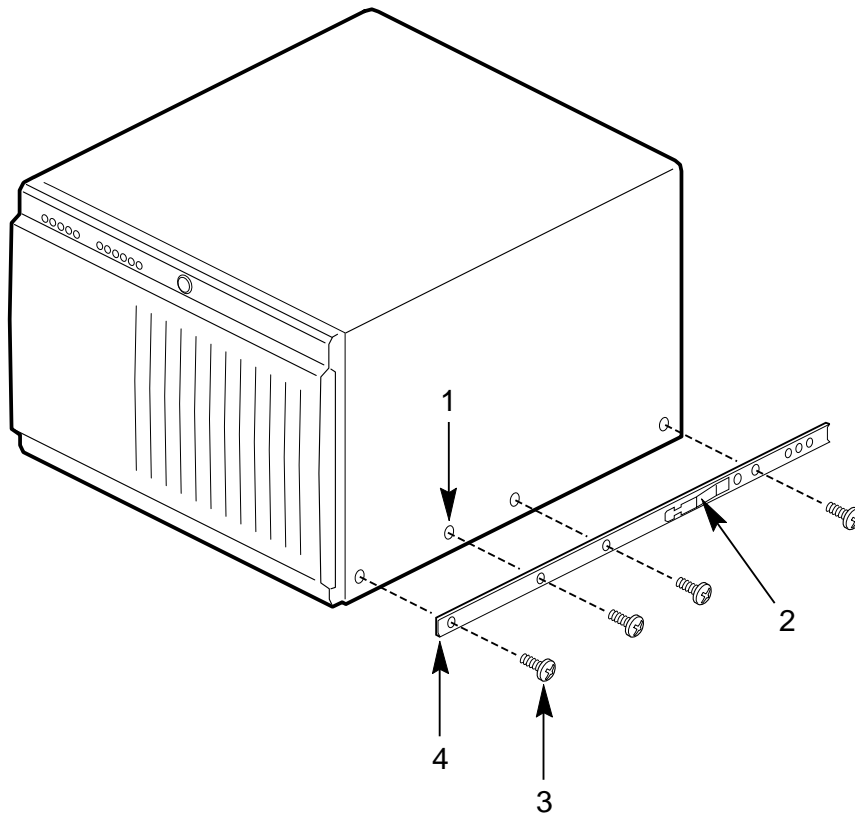

- 1 Threaded hole in chassis
- 2 Safety latch
- 3 Screw
- 4 Small outer bar (right-angle end)

1. Remove four screws from the kit.
2. While facing the side of the server, orient the small bar so that the flat side faces the top and the right-angle end faces the front of the server.
3. Align the first hole in the right-angle end of the bar with the first threaded hole in the side of the chassis.
4. Insert a screw through the hole in the bar and into the chassis wall. Then loosely tighten the screw.
5. Align the rest of the holes in the bar with the remaining three threaded holes along the side of the chassis.
6. Insert three more screws through the bar and into the threaded holes in the chassis wall. Then tighten all four screws firmly.
7. Install the remaining small bar on the other side of the chassis by repeating steps 1–6 above.

Prepare the equipment rack

Before you can install the FT5000 in the 19-inch equipment rack, you must attach the centre bar and large outer bar assemblies to the vertical rails of the rack.

Attach the extension brackets to the equipment rack

NOTE

Mounting holes in the vertical rails of equipment racks are commonly spaced in a precise sequence. Perform the following steps carefully; brackets must be mounted with precision to allow room for the next server you install in a rack.

1. Remove a right-angle extension bracket, two screws, and a bar nut from the kit.
2. While facing the front or back of the rack, orient the right-angle extension bracket so that the short side with the four mounting holes is facing toward the outside edge of the vertical rail.
3. Position the bracket behind the mounting holes in the vertical rail.

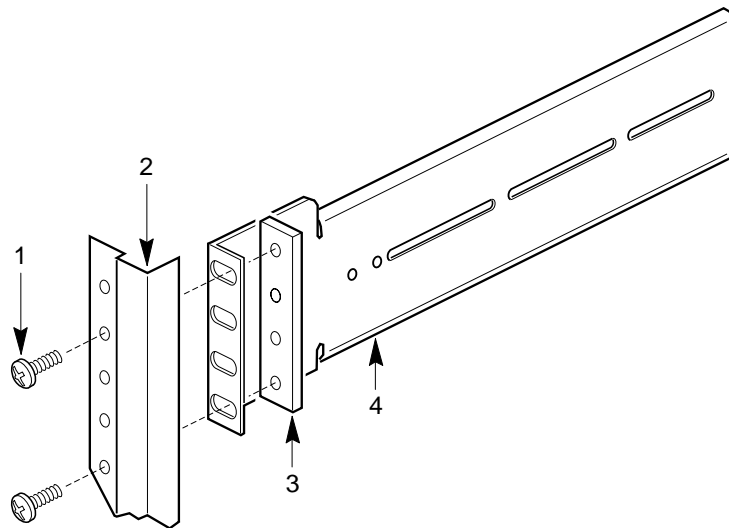

- 1 Screw
- 2 Vertical rail
- 3 Bar nut
- 4 Right-angle extension bracket

4. With a pencil, mark the top and bottom hole locations of the bracket on both sides of the vertical rail; no hole numbers are printed on the rail.
5. Insert a screw through the marked top hole in the rail and through the top hole in the bracket. Place a bar nut on the screw and loosely tighten it. Repeat for the marked bottom hole.
6. Install the three remaining right-angle extension brackets on the other three vertical rails by repeating steps 1–5 above.

Attach the centre bar and large outer bar assemblies to the equipment rack

1. Orient a centre bar and large outer bar assembly so that the flat side is facing toward the brackets attached to the vertical rails and the safety latch on the centre bar is near the back of the rack.

Rack mounting the FT5000

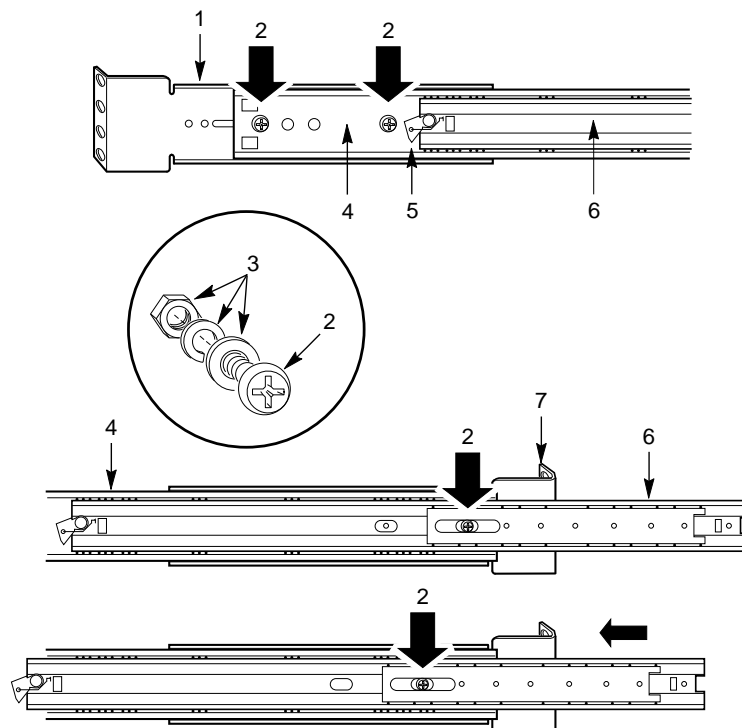

- 1 Back right-angle extension bracket
- 2 Screw
- 3 Flat washer, lock washer and nut
- 4 Large outer bar
- 5 Safety latch on centre bar
- 6 Centre bar
- 7 Front right-angle extension bracket

2. Press the flat side of the outer bar into the U-shaped sections of the brackets.
3. Slide the assembly toward the front of the rack until the end of the outer bar is flush with the end of the U-shaped section of the front bracket.
4. Gently slide the centre bar toward the front of the rack, and position the oblong slot in it over the first hole in the large outer bar. Insert a screw through the hole in the bar and the first hole in the front bracket. Place a lock washer and a nut on the screw, and loosely tighten it.
5. Position the oblong slot in the centre bar over the third hole back from the front of the large outer bar. Insert a screw through the hole and the oblong slot in the front bracket. Place a lock washer and nut on the screw, and loosely tighten it.
6. The back bracket has two holes and three slots in it. This end of the outer bar has four holes in it. Which holes and slots you use depend on the depth of the equipment rack. After fitting the bar into the bracket, insert two screws through the holes in the bar and the appropriate oblong slots in the bracket. Place a lock washer and a nut on each screw, and loosely tighten them.
7. Ensure that the brackets and bars are positioned correctly in the rack. Then tighten all screws firmly.

Install the server in the rack

Read the advisory information at the front of this chapter.

WARNING

The FT5000 server is heavy. It is not advisable to lift it without adequate lifting equipment. The minimum server configuration weighs 38 kg; the maximum weighs 45 kg.

1. Pull the telescoping centre bars out of the large outer bars until they are fully extended and locked in place.
2. Use a mechanical assist unit to carefully pick up the server; gently slide the small bars attached to each side of the server into the extended centre bars.

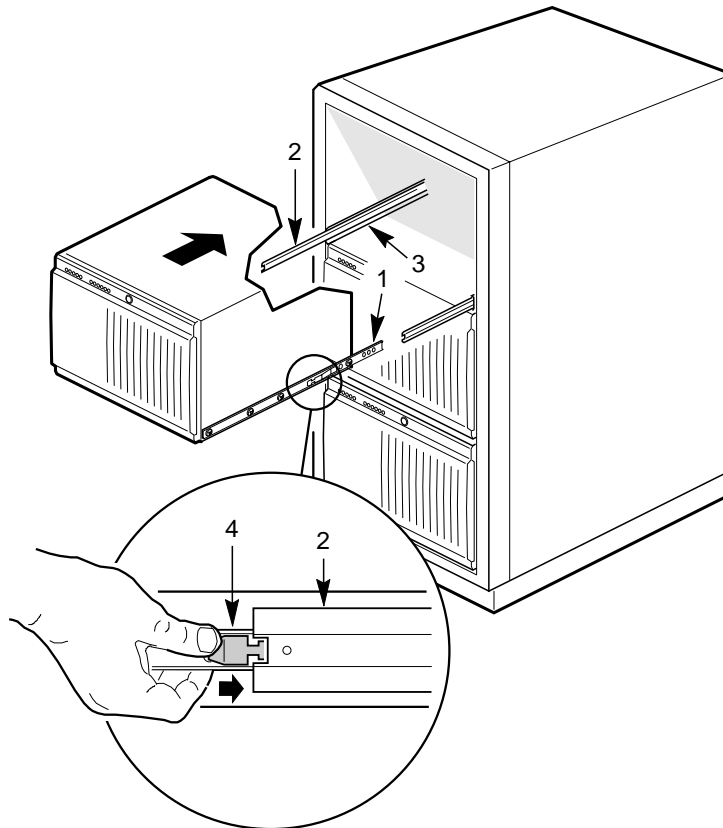

- | | |
|---|-----------------|
| 1 | Small outer bar |
| 2 | Centre bar |
| 3 | Large outer bar |
| 4 | Safety latch |

3. When the server stops, press in on the safety latches on the small bars and gently slide the server into the rack.
4. Connect all external cables and the power cord(s) to the server.

EQUIPMENT LOG AND CONFIGURATION RECORD

Use the blank equipment log provided here to record information about your system. You will need some of this information when you run the SSU.

<i>Item</i>	<i>Manufacturer and Model Number</i>	<i>Serial Number</i>	<i>Date Installed</i>
System			
Mainboard			
Processor speed and cache			
Video display			
Keyboard			
Mouse			
Diskette drive A			
Diskette drive B			
Tape drive			
CD-ROM drive			
Hard disk drive 1			
Hard disk drive 2			
Hard disk drive 3			
Hard disk drive 4			
Hard disk drive 5			
SCSI host adapter board 1			
RAID adapter board 1			
Network adapter board 1			

Equipment log and configuration record

Make a note of it

Use this page to note down other important information such as,

- ◆ Supplier address
- ◆ telephone
- ◆ Installation date
- ◆ Initial software configuration
- ◆ Type of expansion cards fitted and software driver version

It may be useful for any engineer.

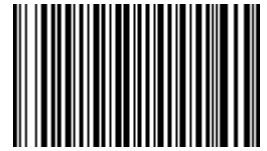

16449331



MITSUBISHI ELECTRIC PC DIVISION

3500 Parkside
Birmingham Business Park
Birmingham B37 7YS
United Kingdom

Tel +44 (0) 121 717 7171
Fax +44 (0) 121 717 7799

MITSUBISHI ELECTRIC PC DIVISION

Niederlassung Deutschland
Gothaer Strasse 27
40880 Ratingen
Germany

Tel +49 (0) 2102 4556
Fax +49 (0) 2102 455700

<http://www.mitsubishi-computers.com>
