

**FIRE DEPARTMENT • CITY OF NEW YORK**



**STUDY MATERIAL FOR THE EXAMINATION FOR  
THE CERTIFICATE OF FITNESS FOR  
STANDPIPE SYSTEM**

**S-13 Supervision of Standpipe System (Citywide)  
(Excludes personal supervision of Multi-zone systems)**

**S-14 Supervision of Multi-Zone Standpipe System  
(Personal supervision of multi-zone systems F.C.905.1.1)**

This book is provided to the public for free by the FDNY.

**FOR COMBINED SPRINKLER/STANDPIPE SYSTEMS A VALID S-12/S-15 IS ALSO REQUIRED.**

ALSO INCLUDED IN THIS BOOKLET YOU WILL FIND THE FOLLOWING:

NOTICE OF EXAMINATION (NOE)

© 03-08-2011 New York City Fire Department - All rights reserved ®  
Official use (Cpgs:31,32,42,45,82)

# Contents

<b>NOTICE OF EXAMINATION .....</b>	<b>4</b>
<b>STUDY MATERIAL AND TEST DESCRIPTION .....</b>	<b>9</b>
<b>PART 1: INTRODUCTION.....</b>	<b>11</b>
<b>PART 2: RESPONSIBILITY OF THE BUILDING OWNER.....</b>	<b>12</b>
<b>PART 3: OUT-OF-SERVICE SYSTEMS (OOS).....</b>	<b>12</b>
<b>PART 4: GENERAL PROCEDURE FOR DETAIL RECORD KEEPING, IMPAIRMENTS &amp; SAFETY.....</b>	<b>17</b>
<b>PART 5: INDIVIDUALS AUTHORIZED TO PERFORM TASKS AS PER NYC FIRE CODE .....</b>	<b>18</b>
<b>PART 6: DEFINITIONS .....</b>	<b>19</b>
<b>PART 7: DIFFERENT TYPES OF STANDPIPE SYSTEMS .....</b>	<b>25</b>
7.1 OVERVIEW OF STANDPIPE SYSTEMS .....	25
7.2 CLASSES OF STANDPIPES SYSTEMS.....	26
7.3 WET (AUTOMATIC) STANDPIPE SYSTEM.....	26
7.5 DRY (AUTOMATIC) STANDPIPE WITH AN AUTOMATIC DRY PIPE VALVE .....	26
7.6 DRY (MANUAL) STANDPIPE WITH A MANUAL CONTROL VALVE .....	27
7.9 YARD SYSTEMS .....	27
7.9.1 PUBLIC WATERWORKS CONNECTION .....	28
7.9.2 PRESSURE TANK .....	28
7.10 COMBINATION / COMBINED SYSTEMS .....	29
7.11 PREACTION STANDPIPE SYSTEMS.....	29
<b>PART 8: STANDPIPE SYSTEM COMPONENTS .....</b>	<b>30</b>
8.1 ROOF MANIFOLD .....	30
8.2 FIRE DEPARTMENT CONNECTION .....	30
8.3 ALARMS AND SUPERVISORY SIGNAL DEVICES .....	32
8.3.1 DEVICES AND EQUIPMENT SUPERVISED .....	32
8.3.2 WATER FLOW ALARMS .....	33
8.3.3 PRESSURE TANK ALARMS .....	33
8.3.4 ALARM RETARDING DEVICES .....	33
8.4 DIFFERENT TYPES OF VALVES .....	33
8.4.1 CHECK VALVES .....	33
8.4.2 SWING CHECK VALVES .....	33
8.4.3 ALARM CHECK VALVES .....	34
8.4.4 CURB VALVES (NON-RISING STEM) .....	34
8.4.5 OS & Y (OUTSIDE SCREW AND YOKE) .....	34
8.5 FIRE HOSE INCLUDING COUPLINGS AND NOZZLES.....	35
8.5.1 FIRE HOSE OUTLET AND RELEASE RACK .....	35
8.5.2 HOSE CABINETS AND STORAGE .....	36
8.5.3 NOZZLES .....	36
8.5.4 HOSE RECORDS (OCCUPANT-USE HOSE) .....	37
8.5.5 OCCUPANT-USE HOSE .....	39
<b>PART 9: WATER SUPPLY.....</b>	<b>40</b>
9.1 PRESSURE TANKS .....	40
9.1.1 PRESSURE TANK ALARMS .....	41
9.1.2 SUPERVISION OF THE PRESSURE TANK .....	41
9.2 GRAVITY TANKS .....	42
9.2.1 GRAVITY TANK SUPERVISION .....	43
9.2.3 COMBINATION GRAVITY TANK AND PRESSURE TANK INSTALLATION .....	44
9.3 FIRE PUMPS .....	44
9.3.1 THE CENTRIFUGAL PUMP .....	44
9.4 THE VERTICAL TURBINE PUMP .....	45

9.4.1 PUMP ACTIVATION ..... 46

9.5 PRESSURE MAINTENANCE PUMPS (JOCKEY PUMPS) ..... 47

9.6 FIRE PUMP LOCATION ..... 47

9.7 OPERATION AND SUPERVISION..... 47

**PART 10: INSPECTION, TESTING AND MAINTENANCE .....48**

**10.1 A COMPLETE SUMMARY OF TASKS OF INSPECTION, TESTING & MAINTENANCE ..... 48**

**10.2 INSPECTION REFERENCE GUIDE..... 59**

**10.3 TESTING REFERENCE GUIDE ..... 64**

**10.4 MAINTENANCE REFERENCE GUIDE ..... 67**

**10.5 INSPECTION, MAINTENANCE & TESTING NOTIFICATION ACTIVITIES AND RECORDS ..... 69**

**PART 11: SIGNAGE REQUIREMENTS .....80**

**11.1 FIRE DEPARTMENT CONNECTION SIGN ..... 80**

**11.2 CONTROL VALVE SIGN ..... 80**

11.3 STAND PIPE SYSTEM SHUTOFF SIGN ..... 80

**11.4 FIRE DEPARTMENT CONNECTIONS SERVING A STANDPIPE SYSTEM SIGN ..... 80**

**11.5 SUPPLY HOSE SIGN ..... 81**

**11.6 STAIRWAYS WITHOUT HOSE CONNECTIONS SIGN ..... 81**

11.7 FIRE HOSE SIGN ..... 81

11.8 ON DRY STANDPIPE WITH NO PERMANENT WATER SUPPLY SIGN..... 81

**PART 12: NYC BUILDING LOCAL LAW 58 OF 2009 .....82**

**PART 13: FIRE DEPARTMENT CODE AND RULES CHAPTER 9.....83**

**13.1 FIRE DEPARTMENT CODE SECTION 905 STANDPIPE SYSTEM ..... 83**

**13.2 FIRE DEPARTMENT RULES § 905-01 STANDPIPE SYSTEM ..... 84**

**PART 14: LIST OF MAJOR CHANGES IN NEW S-13 .....85**

## **NOTICE OF EXAMINATION**

**Title:**

**S-13 Supervision of Standpipe System (excluding multi-zone system) (Citywide)**  
**S-14 Supervision of Multi-Zone Standpipe System**

**Date of Exam:** Written tests are administered Monday through Friday (except legal holidays) at **2:45 PM**: by **appointment only**. Starting processing time for a test is **2:45 PM**. No test will be administered to applicants who arrive after the **3:00 P.M.** To schedule an individual or group appointment, please use this link below:

<http://www1.nyc.gov/site/fdny/business/all-certifications/cof-online-scheduler.page>

### **REQUIREMENTS FOR WRITTEN EXAM**

Applicants must be at least 18 years of age and must have a reasonable understanding of the English language. Applicants must apply the exam in person and bring the following materials and required fee:

1. Applicant must provide two forms of identification, at least one identification must be government issued photo identification, such as a State-issued Drivers' License or Non Driver's License or a passport.
2. Applicants must present a letter of recommendation from his/her. The letter must be on official letterhead, and must state the applicant's full name, experience and the address where the applicant will work. If the applicants are self-employed or the principal of the company, they must submit a notarized letter attesting to their qualifications.
3. Sample of recommendation letter:  
<http://www1.nyc.gov/assets/fdny/downloads/pdf/business/cof-samplerec-letter.pdf>  
Sample of self-employed letter:  
<http://www1.nyc.gov/assets/fdny/downloads/pdf/business/cof-sample-selfrec-letter.pdf>
4. Applicants must present a completed application for certificate of fitness (A-20 Form).  
<http://www1.nyc.gov/assets/fdny/downloads/pdf/business/cof-application-form.pdf>
5. Applicants not currently employed may take the exam without the recommendation letter. If the applicants pass the exam, FDNY will issue a temporary letter with picture for the job seeking purpose. The C of F card will not be issued unless the applicants are employed and provide the recommendation letter from his/her employer.
6. Special requirements for S-14:  
S-14 C of F is required for supervising a premise with multi-zone standpipe system. It is a premises related C of F.

### **7. Application fee:**

Pay the **\$25** application fee in person by one of the following methods:

- Cash
- Credit card (*American Express, Discover, MasterCard, or Visa*)
- Debit card (*MasterCard or Visa*)
- Personal or company check or money order (*made payable to the New York City Fire Department*)

A convenience fee of 2% will be applied to all credit card payments.

For fee waivers submit: ***(Only government employees who will use their C of F for their work-related responsibilities are eligible for fee waivers.)***

- A letter requesting fee waiver on the Agency's official letterhead stating applicant full name, exam type and address of premises; AND
- Copy of identification card issued by the agency

### **TEST INFORMATION**

The S-13 & S-14 test will consist of **75** multiple-choice questions, administered on a "touch screen" computer monitor. It is a time-limit test. A passing score of at least 70% is required in order to secure a Certificate of Fitness. Call (718) 999-1988 for additional information and forms.

### **WEBSITE**

Please always check for the latest revised booklet at FDNY website before you take the test, the Certificate of Fitness Study Material link, below

<https://www1.nyc.gov/assets/fdny/downloads/pdf/business/cof-s14-noe-study-materials.pdf>

#### ***Special material provided during the test:***

The following 3 materials will be provided to you as a reference material when you take the test at Metro Tech, however, the booklet will not be provided to you during the test.

1. Reference Guide for Inspection, testing and maintenance (Section 10.2, 10.3 &10.4)
2. Inspection Testing and Maintenance of Standpipe Systems Activities & Records (Section 10.5)

If all the requirements are met and the applicant passes the exam, a certificate will be issued on the same day. Applicant who fails the exam will receive a failure report. To retake the exam applicants will need to submit a new application and payment.

### **OTHER RELATED FEES**

#### **To change a mailing address:**

Submit a letter requesting the change of mailing address and a copy of your C of F with \$5.00 fee.

#### **To change a work location,**

Submit a letter from your current employer (on company letterhead) confirming that you are an employee and stating your new work location with a copy of your C of F and a \$5.00 fee

#### **To request a replacement certificate:**

Submit a driver's license or passport, social security number, mailing address and a \$5.00 fee.

## **RENEWAL REQUIREMENTS**

This Certificate of Fitness must be renewed every **THREE YEARS**. The renewal fee is **\$15**. FDNY also reserves the right to require the applicants to take a re-examination upon submission of renewal applications.

You will receive a courtesy notice of renewal 90 days before the expiration date. However, it is your responsibility to renew your Certificate. It is very important to renew your C of F before it expires. Renewals submitted 90 days (up to one year) after the expiration date will incur a \$25 penalty in addition to the renewal fee. Certificates expired over one year past expiration date will not be renewed. New exams will be required.

The certificate can be renewed **On-line, by Mail or in Person**.

### • **Renewal online**

If you are an individual, make sure you have your 12 digit Certificate of Fitness Access ID. This can be found on your Renewal Notice. If you do not have your Renewal Notice, your Access ID is your 8 digit Certificate of Fitness number and the last four digits of your social security number. If you are submitting renewals on behalf of a company's employees, the company must be approved by FDNY and have an 8 digit Company Code. To request approval, email [pubrenew@fdny.nyc.gov](mailto:pubrenew@fdny.nyc.gov).

Renewal fee can be paid by one of the following methods:

- Credit card (American Express, Discover, MasterCard, or Visa)
- Debit card (MasterCard or Visa)
- E-check

Fee exempted applicants cannot renew online only by mail or in person.

If all the requirements are met, the certificate of fitness will be mailed out within 10 days.

For online renewal go to: <https://a836-citypay.nyc.gov/citypay/FDNYCOF>

### • **Renewal by mail**

Mail your Renewal Notice (or if you did not receive a Renewal Notice, a copy of your certificate), along with your fee payment, Personal or company check or money order (made payable to the New York City Fire Department)

For fee waivers submit: ***(Only government employees who will use their C of F for their work-related responsibilities are eligible for fee waivers.)***

- A letter requesting fee waiver on the Agency's official letterhead stating applicant full name, exam type and address of premises; **AND**
- Copy of identification card issued by the agency and if applicable, supporting documents to:

**NYC Fire Department (FDNY)**  
Cashier's Unit  
9 MetroTech Center, 1st Floor  
Brooklyn, NY 11201

If all the requirements are met, the certificate of fitness will be mailed out within four to six weeks.

• **Renewal in person**

Submit your Renewal Notice (or if you did not receive a Renewal Notice, a copy of your certificate), along with your fee payment by one of the following methods:

- Cash
- Credit card (*American Express, Discover, MasterCard, or Visa*)
- Debit card (*MasterCard or Visa*)
- Personal or company check or money order (*made payable to the New York City Fire Department*)

For fee waivers submit: ***(Only government employees who will use their C of F for his or her work-related responsibilities are eligible for fee waivers.)***

- A letter requesting fee waiver on the Agency's official letterhead stating applicant full name, exam type and address of premises; **AND**
- Copy of identification card issued by the agency and if applicable, your supporting documents to:

**NYC Fire Department (FDNY)**  
Cashier's Unit  
9 MetroTech Center, 1st Floor  
Brooklyn, NY 11201

If all the requirements are met, the certificate of fitness will be issued the same day.

**A convenience fee of 2 % will be applied to all credit card payments for original or renewal certificates.**

**Test Site: FDNY Headquarters, 9 Metrotech Center, Brooklyn, NY. Enter through the Flatbush Avenue entrance (between Myrtle Avenue and Tech Place).**

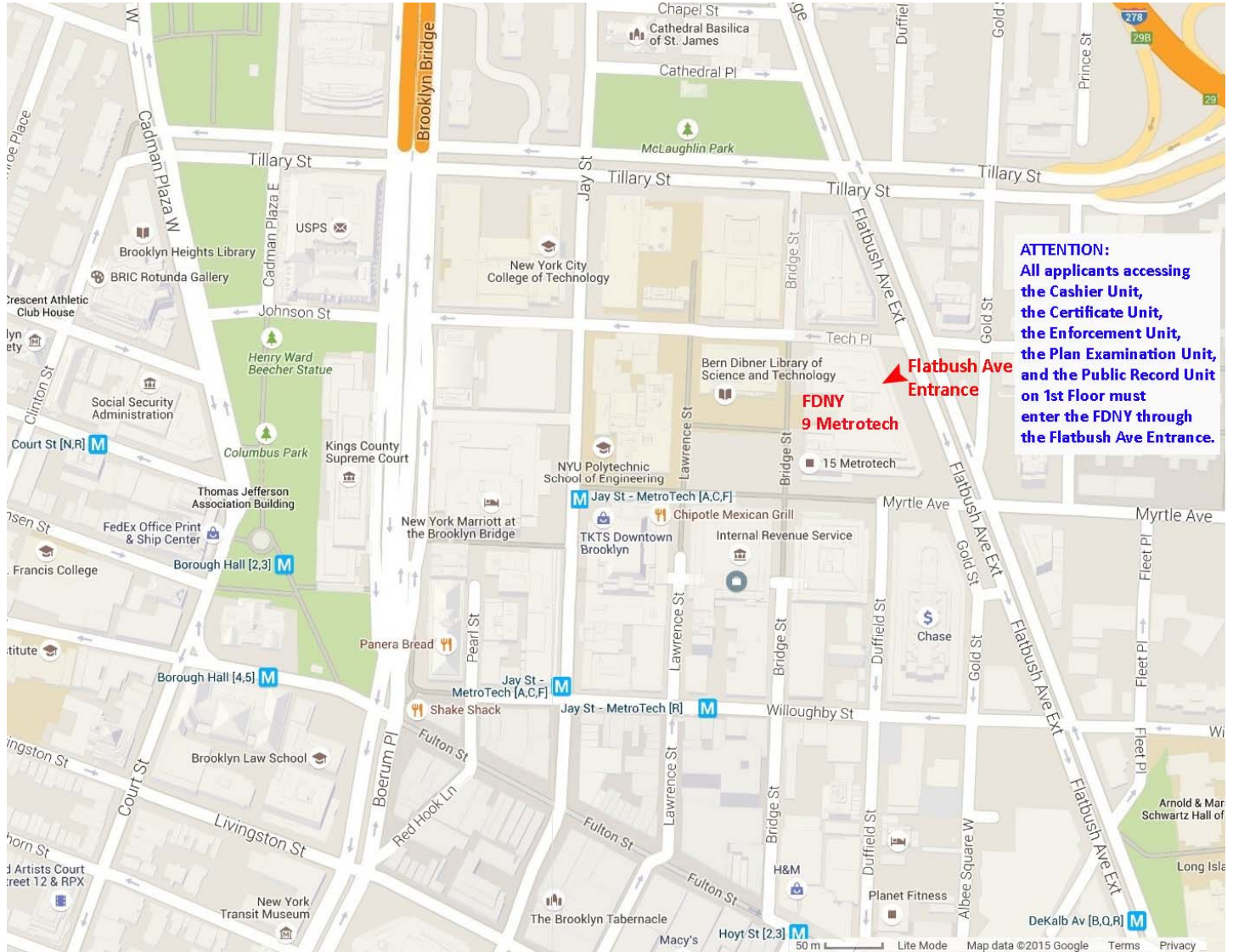



## **Study Material and Test Description**

### **About the booklet**

This study material will help you prepare for the written examination for the Certificate of Fitness (**C of F**) for Standpipe Systems. The study materials include information taken from the New York City Fire Code (FC) Chapter 9 and Fire Department Rules Chapter 9 and NFPA Standard 25, 2011 Edition Inspection, Testing and Maintenance of Water based Fire Protection Systems. **It is critical that you read AND understand this booklet to help increase your chance of passing this exam.**

### **About the Test**

You must pass a multiple choice test to qualify for the C of F. A score of 70% correct is required in order to pass the test. All questions have four answer options. Only **one** answer is correct for each question. If you do not answer a question, or if you mark more than one answer to a single question, your answer to that question will be scored as incorrect. Read each question carefully before marking your answer. There is no penalty for guessing.

### **SAMPLE QUESTIONS**

*The following questions represent the “format” of the exam questions, not the content of the real exam.*

#### **1. Which of the following are allowed to be used while taking a Certificate of Fitness examination at 9 Metro Tech Center?**

- I. cellular phone
- II. study material booklet
- III. reference material provided by the FDNY
- IV. mp3 player

- A. III only
- B. I, II, and III
- C. II and IV
- D. I only

Only reference material provided by the FDNY is allowed to be used during Certificate of Fitness examinations. Therefore, the correct answer would be A. You would touch “A” on the computer terminal screen.

#### **2. If the screen on your computer terminal freezes during your examination, who should you ask for help?**

- A. the person next to you
- B. the firefighters in the testing room

- C. the examiner in the testing room
- D. the computer help desk

If you have a computer related question, you should ask the examiner in the testing room. Therefore, the correct answer would be C. You would touch "C" on the computer terminal screen.

**3. If you do not know the answer to a question while taking an examination, who should you ask for help?**

- A. the person next to you
- B. the firefighters in the testing room
- C. the examiner in the testing room
- D. you should not ask about test questions since FDNY staff cannot assist applicants

You should not ask about examination questions or answers since FDNY staff cannot assist applicants with their tests. Therefore, the correct answer would be D. You would touch "D" on the computer terminal screen.

## **PART 1: INTRODUCTION**

---

A standpipe system is piping installed in a building that serves to transfer water to hose connections located within the building for firefighting purposes. Whether a building must be provided with standpipe system or not is generally set forth in the NYC Building Code, however the Fire Code does contain several standpipe requirements, such as for high piled combustible storage and for buildings constructed on streets of substandard width. Inspection, testing, servicing and other maintenance of standpipe systems must be performed in accordance with NFPA (National Fire Protection Association) 25, 2011 edition and NFPA 1962, 2008 edition for the Standard for the Inspection, Care, and Use of Fire Hose, Couplings, and Nozzles and the Service Testing of Fire Hose. Multi-zoned standpipe systems must be personally supervised by a constantly attending S-14 Certificate of Fitness person.

All multiple dwellings, factories, office buildings, warehouses, stores and offices, theaters and music halls, hospitals and asylums, public schools and other public buildings, churches and other places where large numbers of persons are congregated for purposes of worship, instruction or amusement, and all piers, bulkheads, wharves, pier sheds, bulkhead sheds or other waterfront structures shall provide such fire hose, fire extinguishers, buckets, axes, fire hooks, fire doors and other means of preventing and extinguishing fires as the commissioner may direct.

Required fire protection systems shall be extended or altered as necessary to maintain and continue protection whenever the building or structure is altered. Systems not complying with this study material shall be considered to be impaired.

## **PART 2: RESPONSIBILITY OF THE BUILDING OWNER**

---

It shall be the building owner's responsibility to maintain the standpipe system and to determine the individual qualifications and competencies of the COF holder that performs the functions related to inspection, testing and maintenance of such standpipe system.

### **IMPAIRMENT COORDINATOR**

The building owner shall assign an impairment coordinator to comply with the requirements of this study material. The impairment coordinator shall take the action(s) when a standpipe system, sprinkler system or fire alarm system is out of service.

The impairment coordinator shall maintain records of all system inspections, tests, servicing and other items of maintenance, these records shall be kept on the premises or other approved location for a minimum of 3 years (except for witnessed FDNY, 5 years). These records shall be made available for inspection by any member of the FDNY. In absence of a specific designee, the building owner shall be considered the impairment coordinator.

## **PART 3: OUT-OF-SERVICE SYSTEMS (OOS)**

---

### **PLANNED REMOVAL FROM SERVICE**

The impairment coordinator shall be made aware in advance of any planned removal from service of a standpipe system, sprinkler system, fire alarm system, or system components. He/she shall be made aware of repair, servicing, alteration, testing and other maintenance of the system or component, or to allow construction to be performed in the area protected by the system without unnecessarily activating it. The impairment coordinator shall authorize and personally supervise the placing of the fire protection system out of service. Before authorizing the placing of the fire protection system out of service, the impairment coordinator shall:

- Notify the Certificate of Fitness holder responsible for supervising the maintenance of the standpipe system, sprinkler system or fire alarm system.
- Determine the extent and expected duration of the out-of-service condition.
- Inspect the areas or buildings involved and assess the increased risks.
- Make appropriate recommendations to the owner.
- Notify the Fire Department in accordance with FC 901.7.5, if required.
- Notify the responsible person designated by the owner to issue hot work authorizations in accordance with FC Chapter 26.
- Notify the central station and insurance carrier.
- Notify the occupants in the affected areas if the duration of time the sprinkler system or the fire alarm system will be out of service is estimated to be more than 30 minutes.
- Place a tag at each Fire Department connection, standpipe and sprinkler system control valve and fire command center, indicating which fire protection system, or part thereof, is out of service.
- Maintain the fire protection system in service until work is ready to begin.

### **OUT-OF-SERVICE STANDPIPE SYSTEMS AT CONSTRUCTION SITES**

The Owner, Fire Safety Manager and/or Impairment Coordinator shall immediately notify the Fire Department of any unplanned out-of-service condition, and comply with the requirements for unplanned out-of-service condition.

1. Immediately notify the Fire Department of any unplanned out-of-service condition, and otherwise comply with the requirements of Fire Code section 901.7.4
2. Notify the Fire Department at least 24 hours prior to any planned removal of the standpipe system from service and otherwise comply with the requirements of Fire Code section 901.7.3
3. Ensure that a fire watch is continuously maintained in compliance with the requirements of Fire Code section 901.7.2 while the standpipe system is out-of-service
4. Repair the standpipe system and return it to service in compliance with the requirements of Fire Code section 901.7.6 and Section 3303.8.1 of the NYC Building Code. The construction site may continue to be occupied, and construction, demolition or alteration activities may continue, pending such repair and restoration to service, except:
  - as otherwise provided in Section 3303.8.1 of the NYC Building Code; and/or
  - as otherwise directed by the commissioner upon a determination that, in the absence of an operable standpipe system, the conduct of certain construction, demolition or alteration activities would be imminently perilous to life or property; and that in no circumstance shall hot work be conducted on the construction site until such time as the standpipe system is restored to service and the standpipe alarm reactivated.

### **UNPLANNED OUT-OF-SERVICE CONDITION**

Any person, upon becoming aware of any condition, except a planned removal from service, rendering a standpipe system, sprinkler system or fire alarm system, or part thereof, inoperable in whole or in part, shall notify the owner and the impairment coordinator of such condition. The impairment coordinator shall take the actions as required by the code and such other actions as are necessary or appropriate to protect the occupants of the building and promptly restore the system to service.

### **FIRE WATCH AND FIRE GUARDS**

When a Fire Protection system is out-of-service, fire watch personnel must:

- Continuously patrol the area affected by the out-of-service fire protection system to which such person has been assigned, keeping constant watch for fires.
- Be provided with at least one approved mean for notifying the Fire Department and emergency preparedness staff.
- Immediately report any fire to the Fire Department and notify emergency preparedness staff on premises.
- Be trained in the use of portable fire extinguisher.
- Be responsible for extinguishing fires limited in size and spread that can be readily extinguished.
- Maintain a record of such fire watch on the premises during the fire watch and for a minimum of 48 hours after the fire watch has concluded.
- Have no other duties.

The fire watch for an out-of-service standpipe, sprinkler or fire alarm system shall be maintained by one or more fire guards. The impairment coordinator or other building staff trained and knowledgeable in in conducting a fire may conduct a fire watch in lieu of a fire guard during the initial 4 hours of a planned removal from service, or after discovery of an unplanned out of service condition, provided that the floor area in which the fire protection system is out of service does not exceed 50,000 sq. ft.

**FIRE DEPARTMENT NOTIFICATIONS FOR OUT OF SERVICE CONDITIONS**

Notification to the Fire Department shall be made when a standpipe system is out-of-service for any period of time.

The telephone numbers are as follows:

<b>Manhattan</b>	<b>212-570-4300</b>
<b>Bronx</b>	<b>718-430-0200</b>
<b>Brooklyn</b>	<b>718-965-8300</b>
<b>Queens</b>	<b>718-476-6200</b>
<b>Staten Island</b>	<b>718-494-4296</b>

**a) THE INITIAL FIRE DEPARTMENT NOTIFICATION SHALL INCLUDE THE FOLLOWING:**

1. The owner or impairment coordinator’s name and contact information;
2. The building address;
3. The type of fire protection system that is out of service;
4. Whether the fire protection system is out of service by reason of a planned removal from service (and if so, the reason for placing it out of service) or an unplanned out-of-service condition;
5. If a planned removal from service, the date and time the fire protection system will be placed out of service, and the estimated duration the system will be out of service;
6. If an unplanned out-of-service condition, the estimated duration the system will be out of service;
7. The floors or areas in which the fire protection system is out of service;
8. Whether the other fire protection systems are in good working order; and
9. The name and certificate number of the certificate of fitness holder responsible for supervision of the fire protection system that is out of service.

**b)** When a Certificate of Fitness holder observes a major defect or out-of-service system, he/she shall report the defect to the borough dispatcher, the owner, and any responsible parties.

**c)** When the Certificate of Fitness holder observes a minor defect or other condition not presenting a serious safety hazard, he or she shall report the defect or condition to the owner, and if the defect or condition is not corrected within 30 days it shall be deemed to be an impairment and reported in writing to the Fire Department (FC 901.7.5). Correspondence should be sent via email [spkstp@fdny.nyc.gov](mailto:spkstp@fdny.nyc.gov) or by certified documents to:

**New York City Fire Department  
Bureau of Fire Prevention  
Fire Suppression Unit, 3<sup>rd</sup> Floor  
9 Metro Tech Center  
Brooklyn, New York 11201**

**IDENTIFYING OOS SYSTEMS USING DISCS/TAGS**

Systems that are out-of-service, both planned and unplanned, shall be immediately identified by placing a tag at each of the following locations:

- Fire Department connections;
- System control valves;
- Fire Command Center or other clearly visible location in the lobby of the building;

Indicating which system or part thereof is out of service. Impairment coordinators / building owners shall ensure the placement of these tags by Master Fire Suppression Piping Contractors (MFSPC's) or Master License Plumber (MLP) (as restricted). In addition, for an unplanned out-of-service condition, a disc (white or blue) shall be placed at all affected Fire Department connections to inform responding Fire Department units of the out-of-service condition. The impairment coordinator / building owner shall ensure placement of these discs by MFSPC's, MLP's (as restricted) or FDNY units. When the condition has been corrected, the disc(s) shall be removed immediately.

**TAG REQUIREMENT**

A tag shall be used to indicate that a system, or portion, is out of service. MFSPC, Class A or B, or a MLP (as restricted), shall be required to post tags at the main control valve and at any closed sectional valves serving areas affected. The tag shall indicate the area affected, a brief description of the condition, the occupancy classification, C of F number and the estimated time until the system becomes operational.

Drain test results shall be posted on the tag indicating both the static and flow pressures before and after the system was placed in an out-of-service condition.

If no impairment is found in the entire system **green** tags will be placed on the main control valve.

**SYSTEMS PARTIALLY OR FULLY OUT OF SERVICE**

**SYSTEMS FULLY OUT OF SERVICE**

The impairment coordinator/building owner shall ensure that the local administrative fire company, MFSPC (Class A or B) or MLP's (as restricted) has placed one **White** disc 8 to 9 inches in diameter on all affected Fire Department connections. A **RED** tag shall be placed at

Example of FDNY White and Blue Discs



the main control valve indicating the standpipe company name, date of removal from service and anticipated return to service date.

**SYSTEMS PARTIALLY OUT OF SERVICE**

The impairment coordinator/building owner shall ensure that the local administrative fire company, FSPC’s or FDNY units Master Fire Suppression Contractor Class A or B has placed one **Blue** Disc 8 to 9 inches in diameter on all affected fire department connections. A **Red** tag shall be placed at the main control valve and any closed sectional valve indicating the company name, date of removal from service and anticipated return to service date.

**IMPAIRED EQUIPMENT**

Underground service mains, water storage tanks, Fire Department connections, control valves, fire and or booster pumps, that are out-of-service and are considered vital to part of the system are required to be tagged following procedures outlined in Chapter 15 of NFPA 25 2011 Ed.

**TAGS PLACED AT CONTROL VALVES SHALL INDICATE THE LEVEL OF IMPAIRMENT OR DEFECT AS FOLLOWS:**

	<u>Tag</u>	<u>Disc</u>
System fully or majorly out of service	<b>Red</b>	<b>White</b>
System is found with critical deficiency	<b>Orange</b>	<b>Blue</b>
System is found with non-critical deficiencies	<b>Yellow</b>	<b>Blue</b>
System appears free of defects or deficiencies	<b>Green</b>	<b>N/A</b>

*\*See deficiency clarification table for details.*

Only FDNY, Owner, MFSPC or MLP (as restricted) may place a tag on a system. For systems that are fully or partially out of service that are not equipped with Fire Department connections, the appropriate tags shall be placed at the main control valve. FDNY is to be notified immediately.

**PRIOR TO RETURNING A SYSTEM TO SERVICE, THE IMPAIRMENT COORDINATOR SHALL ENSURE THAT:**

- the necessary tests and inspections are conducted;
- the system is operating normally;
- FDNY borough dispatcher is notified;
- building owner’s tenants in the affected area are notified;
- insurance carrier is notified;
- emergency preparedness staff are notified;
- central station operator (if so equipped) is notified;
- out-of-service tags and discs are removed.



**PART 4: GENERAL PROCEDURE FOR DETAIL RECORD KEEPING, IMPAIRMENTS & SAFETY**

---

**IT SHALL BE THE RESPONSIBILITY OF THE S-13/S-14 CERTIFICATE OF FITNESS HOLDER TO PERFORM THE FOLLOWING:**

**RECORD KEEPING**

S-13/S-14 Certificate of Fitness holder shall maintain a detailed record of all inspections.

**RECORDS**

Records of all system inspections, tests, servicing and other maintenance required by the NYC Fire Code, NYC Fire Rules or the referenced standards shall be maintained on the premises or other approved location for a minimum of 3 years and made available for inspection by any Fire Department representative. (FC 901.6.2)

**DETAILED RECORDS**

A detailed inspection report shall include information relative to conditions of the water supply, gravity and pressure tanks and levels therein, valves, risers, piping, sprinkler heads, Fire Department connections, alarms, fire, booster and special service pumps, obstructions and conditions of all other system equipment and appurtenances. All defects and/or impairments shall be noted on the report. Records shall be readily available to any representative of the Fire Department.

**RISER CARD**

In addition to those records required by NFPA 25 as mentioned above, an approved card bearing the dates of each inspection, Certificate of Fitness number and signature of the Certificate of Fitness holder shall be posted on the premises near the main water supply control valve. (This approved card shall not replace or supersede the detailed record of inspection).

Notification of all defects shall be reported to the owner or their representative by the Certificate of Fitness holder. After 30 days, any of the defects that have not been corrected shall be immediately reported to the Fire Department Borough Communication Office. Failure to make inspections, maintain records, and report defects or violations may be cause for revocation of the Certificate of Fitness and court enforcement proceedings.

---

## **PART 5: INDIVIDUALS AUTHORIZED TO PERFORM TASKS AS PER NYC FIRE CODE**

1. **S-13 or S-14 Certificate of Fitness holder** - visual inspections only, proper notification and keeping record of inspection results for examination by the FDNY.
  2. **S-13\* C of F for Refrigeration Operating Engineer (Q-01 & Q-99), NYC High Pressure Operating Engineer, NYS High Pressure Operating Engineer** - permitted to perform visual inspections, test notification appliances, perform daily and weekly routine maintenance and record all inspection, testing and maintenance results for examination by FDNY.  
\* (For employees of a single or multiple properties under common ownership employed by the same building owner/management company).
  3. **S-14 C of F holder employed by a site-specific building owner with the following certifications: Refrigeration Operating Engineer (Refrigeration Q-99 & Q-01), High Pressure Operating Engineer and NYS High Pressure Operating Engineer** - permitted to perform visual inspections, test notification appliances, perform daily and weekly routine maintenance and record all inspection, testing and maintenance results for examination by FDNY.
  4. **Master Fire Suppression Piping Contractor (MFSPC) Class A or B with S-13 C of F** - permitted to inspect, test, maintain and repair/replace all fire standpipe and sprinkler systems components, record maintenance, inspection and test results for examination and evaluation by FDNY.
  5. **Master Plumber (MP) with S-13 for Standpipe Systems that are NOT combined with sprinkler systems** - permitted to inspect, test, maintain and repair/replace all fire standpipe systems, record of maintenance, inspection and test results for examination by FDNY.
-

## **PART 6: DEFINITIONS**

---

**ALARM NOTIFICATION APPLIANCE** - A fire alarm system component, such as a bell, horn, speaker, light, text display or vibration device that issues an audible, tactile, and/or visual alert.

**ALARM SIGNAL** - A signal indicating an emergency requiring immediate action, such as a signal indicative of fire.

**AUTOMATIC BALL DRIP** - An automatic drain valve horizontally installed at the low point in the piping between the lower check valve and the Fire Department connection of automatic sprinkler systems. Water pressure from a Fire Department pumper automatically closes this valve. It automatically re-opens when pressure ceases, permitting this piping to drain and thereby preventing freezing.

**AUTOMATIC STANDPIPE SYSTEM** - A standpipe system that is attached to a water supply capable of supplying the system demand at all times and that requires no action other than opening a hose valve to provide water at hose connections.

**AUXILIARY WATER SUPPLY** - supplementary source of water for a standpipe system.

**BRANCH LINE** - A pipe system, generally in a horizontal plane, connecting not more than one hose connection with a standpipe.

**CENTRAL STATION** - A facility that receives alarm signals from a protected premises and retransmits or otherwise reports such alarm signals to the department.

**COMBINATION STANDPIPE AND SPRINKLER SYSTEM** - A system where the water piping services fire hose outlets for Fire Department use and outlets for automatic sprinklers.

**CONTROL VALVE** - A valve controlling flow to water-based fire protection systems. Control valves do not include hose valves, inspector's test valves, drain valves, trim valves for dry pipe, pre-action and deluge valves, check valves, or relief valves.

**OS & Y VALVE** (Outside Stem and Yoke valve) - an indicating type of control valve used for fire a standpipe system.

**CURB VALVE** - a non-indicating gate valve equipped with a cast iron extension box flushed with a sidewalk with an operating nut of 1 ¼ inch, this valve is operated using a special curb key wrench. This valve controls the municipal water supply serving the standpipe system.

**DEFICIENCY** - A condition in which the application of the component is not within its designed limits or specifications.

**CRITICAL DEFICIENCY** - A deficiency that, if not corrected, can have an effect on the performance of the fire protection system.

**NON CRITICAL DEFICIENCY** - A deficiency that does not have an effect on the performance of the fire protection system, but correction is needed for the proper inspection, testing, and maintenance of the system(s).

**DELUGE VALVE** - A water supply control valve intended to be operated by actuation of an automatic detection system that is installed in the same area as the discharge devices. Each deluge valve is intended to be capable of automatic and manual operation. Deluge systems are suitable for hazardous occupancies.

**DISCHARGE DEVICE** - A device designed to discharge water or foam-water solution in a predetermined, fixed, or adjustable pattern. Examples include spray nozzles and hose nozzles.

**DRY STANDPIPE** - A standpipe system designed to have piping contain water only when the system is being utilized.

**MANUAL DRY STANDPIPE** - A dry standpipe system without an automatic water supply. This system requires the connection of fire department apparatus via the fire department connection for operation.

**AUTOMATIC DRY STANDPIPE** - A dry standpipe system that is supplied by an automatic water supply. A dry or deluge valve is used to maintain the system without water until it is needed for fire-fighting purposes.

**FIRE ALARM SYSTEM** - Any system, including any interconnected fire alarm sub-system, of components and circuits arranged to monitor and annunciate the status of fire alarm or supervisory signal-initiating devices.

**FIRE DEPARTMENT CONNECTION** - A connection, normally on the exterior of the building, through which the Fire Department can pump supplemental water into the standpipe system, furnishing water for fire extinguishment to supplement existing water supplies. (Formerly referred to as a Siamese connection.)

**FIRE HOSE** - A flexible conduit constructed with one or more reinforcements (Jackets), with or without a coating or covering but with an approved non-permeable lining, or with an inner reinforcement between a protective cover and an approved non-permeable lining.

**FIRE HYDRANT** - A valve connection on a water supply system having one or more outlets and that is used to supply hose and fire department pumps with water.

**FIRE PROTECTION SYSTEM** - Approved devices, equipment and systems or combinations of systems used to detect a fire, activate an alarm, extinguish or control a fire, control or manage smoke and products of a fire or any combination thereof, including fire extinguishing systems, fire alarm systems, sprinkler systems and standpipe systems. A pump used only to fill a tank is not a fire pump. The following fire pumps are required to be maintained in accordance with the NYC Fire Code.

**FIRE PUMP** - A pump that provides water at an increased volume and pressure dedicated to a fire standpipe system. A fire pump is a part of a fire standpipe system's water supply and may be powered by electric, diesel or steam. The pump intake is either connected to the public underground water supply piping or a static water source (e.g., tank, reservoir, lake). A pump used only to fill a tank is not a fire pump. The following fire pumps are required to be maintained in accordance with the NYC Fire Code.

**FIRE PUMP, AUTOMATIC STANDPIPE** - A fire pump located at or below street level that supplies the lower 300 feet of a standpipe system or a combined standpipe and sprinkler system.

**FIRE PUMP, FOAM** - A fire pump used to boost water supply pressures in a fire protection system where such system uses firefighting foam as an additive.

**FIRE PUMP, LIMITED SERVICE** - A fire pump with a motor rating not exceeding 30 hp and utilizing a limited service fire pump controller.

**FIRE PUMP, SPECIAL SERVICE** - A fire pump that is located above street level and that receives its water supply from a gravity tank or suction tank supplying water to fire sprinkler/standpipe system and/or Fire Department hose outlets. Special service pumps shall be maintained according to NFPA 25 standard for fire pumps.

**FOLD** - A transverse bend (fold) occurring where the hose is lengthwise double over on itself, as on a pin rack.

**GALLONS PER MINUTE (GPM)** - typically used to measure fluid flow rate (such as water) or pump capacity. Measurement of water flow rate for a pump or a fire standpipe system.

**GENERAL SUPERVISION** - Supervision by the holder of any department certificate who is responsible for performing the duties set forth in NYC Fire Code but need not be personally present on the premises at all times.

**HOSE CONNECTION** - a combination of equipment provided for connection of a hose to the standpipe system that includes a hose valve with a threaded outlet.

**HOSES:**

**ATTACK** - Two and a half in (2-1/2") fire hose designed to be used by trained fire fighters and fire brigade members to combat fires beyond the incipient stage.

**BOOSTER** - A non-collapsible hose used under positive pressure having an elastomeric or thermoplastic tube, a braided or spiraled reinforcement, and an outer-protective cover.

**COVERED** - A hose with a jacket covered and lined with a continuous synthetic rubber or plastic. The cover is usually thicker than a coating.

**FIRE** - A flexible conduit used to convey water.

**HOSE VALVE** - The valve to an individual hose connection.

**OCCUPANT USE** - One and a half inch (1-1/2") fire hose designed to be used by the building's occupants to fight incipient fires prior to the arrival of trained fire fighters or fire brigade members.

**UNLINED** - A hose consisting of only a woven jacket that is usually of linen yarns and is of such quality that the yarn swells when wet, tending to seal the hose.

**IN SERVICE** - The status of hose stored in a hose house, on a rack or reel, or on a fire apparatus that is available and ready for immediate use at an incident. This doesn't include hose in the storage where it is not readily available to be put into service at an incident.

**IN STORAGE** - A hose that is not readily available for use because it is not at the scene of an incident and not loaded on a vehicle that can transport it to the scene.

**IN USE** - Hose being used during fire suppression or during training.

**HOSE SIZE** - An expression of the internal diameter of the hose.

**HOSE STATION** - a combination of a hose rack, hose nozzle, hose, and hose connection.

**HYDRAULIC PLACARD** - A sign attached to a hydraulically calculated standpipe system indicating the design density, required gallons per minute and pressure for the system to operate properly.

**HYDRAULICALLY CALCULATED SYSTEMS** - A method of sizing standpipe piping using a prescribed amount of water to be delivered to the hydraulically most remote hose station.

**IMPAIRMENT** - A condition where a fire protection system or unit or portion thereof is out of order, and the condition can result in the fire protection system or unit not functioning in a fire event.

**IMPAIRMENT COORDINATOR** - The person responsible for ensuring that proper safety precautions are taken when a fire protection system is placed out of service. The building owner shall assign an impairment coordinator to comply with the requirements of this document. In the absence of a specific designee, the owner shall be considered the impairment coordinator.

**LABELED** - Equipment or materials to which has been attached a label, symbol or other identifying mark or an organization that is acceptable to the authority having jurisdiction

and concerned with product evaluation, that maintains periodic inspection of production of labeled equipment or materials, and by whose labeling the manufacturer indicates compliance with appropriate standard or performance in a specified manner.

**LISTED DEVICE** - A fire protection component that has been tested to perform under parameters specified for its use by a nationally recognized testing agency. Underwriter's Laboratory (UL) and Factory Mutual (FM) are the two most common ones.

**MANUAL STANDPIPE** - Standpipe system that relies exclusively on the fire department connection to supply the system demand.

**MASTER PRESSURE REDUCING VALVE** - A pressure reducing valve installed to regulate pressures in an entire fire protection system and/or standpipe system zone.

**MAIN DRAIN** - The primary drain connection located on the system riser and also utilized as a flow test connection. These valves are typically globe pattern valves.

**MICROBIOLOGICALLY INFLUENCED CORROSION (MIC)** - Corrosion caused by the presence of microbes in the water supply that over time attack the interior of metallic piping and cause leaks, pitting, and blockages.

**OCCUPANT-USE HOSE** - Fire Hose designed to be used by the building's occupants to fight incipient fires prior to the arrival of trained fire fighters or fire brigade members.

**OUT OF SERVICE SYSTEM** - A fire protection system that is not fully functional; or whose operation is impaired or is otherwise not in good working order.

**PERSONAL SUPERVISION** - Supervision by the holder of a FDNY Certificate of Fitness who is required to personally present on the premises, or other proximate location acceptable to the department, while performing the duties for which the certificate is required.

**POUNDS PER SQUARE INCH (PSI)** - A unit of pressure measuring force per unit area.

**PRESSURE CONTROL VALVE** - A pilot operated pressure-reducing valve designed for the purpose of reducing the downstream water pressure to a specific value under both flowing (residual) and non-flowing (static) conditions.

**PRESSURE-REDUCING VALVE** - A valve designed for the purpose of reducing the downstream water pressure under both flowing (residual) and non-flowing (static) conditions.

**PRESSURE REGULATING DEVICE** - A device designed for the purpose of reducing, regulating controlling, or restricting water pressure. Example includes pressure reducing valve, pressure control valves, and pressure-restricting devices.

**PRESSURE RESTRICTING DEVICE** - A valve or device designed for the purpose of reducing of reducing the downstream water pressure under flowing (residual) conditions only.

**PRESSURE RELIEF VALVE** - A valve designed for the purpose of releasing excess air or water pressure from a fire protection piping system. Pressure relief valve is not a pressure reducing valve.

**PRESSURE TANK** - A tank using air pressure to supplying water for water-based fire protection systems. Tank contents to be maintained at one third air to two thirds water.

**SERVICE TEST** - Hydrostatic test conducted by users on all in-service hose to determine suitability for continued service.

**STANDPIPE SYSTEM** - An arrangement of piping, valves, hose connections, and allied equipment installed in a building or structure, with the hose connections located in such a manner that water can be discharged in streams or spray patterns through attached

hose and nozzles, for the purpose of extinguishing a fire, thereby protecting a building or structure and its contents in addition to protecting the occupants.

Piping installed in a building or structure that serves to transfer water from a water supply to hose connections at one or more locations in a building or structure used for firefighting purposes.

**STANDPIPE, MULTI-ZONE** - A standpipe system that is vertically subdivided as required by the construction codes, including the NYC Building Code, into zones to limit the maximum operating pressure in the system. Each zone will have its own individual automatic water supply.

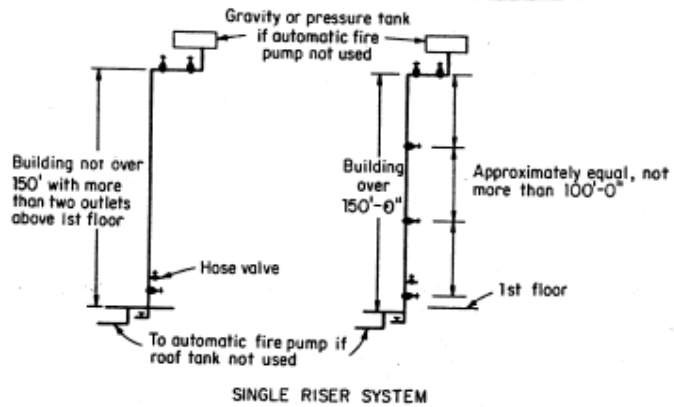
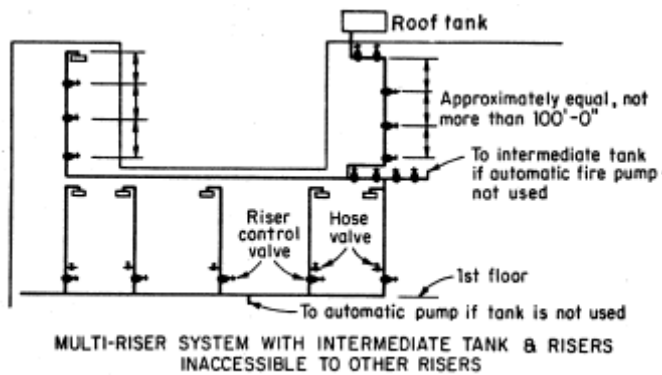
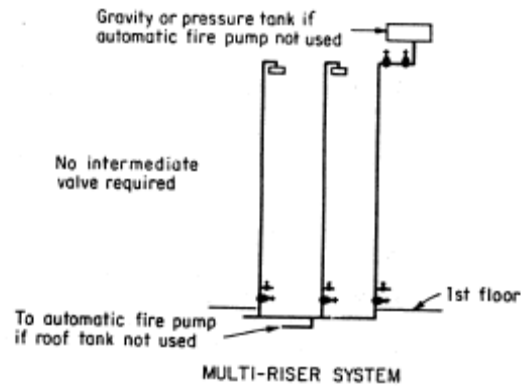
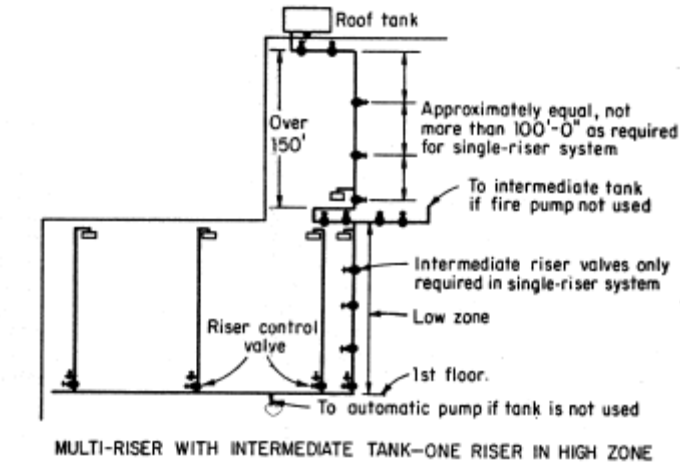

**STATIC PRESSURE** - The measurement of system pressure under no-flow condition.

**STRAINER** - A device capable of removing from the water all solids of sufficient size that are obstructing water spray nozzles.

**SUPERVISORY SIGNAL** - Signal indicating the need for action in connection with the supervision of guard tours, fire extinguishing systems or equipment, fire alarm systems or the maintenance features of related systems.

**SUPERVISORY SIGNAL-INITIATING DEVICE** - An initiating device, such as a valve supervisory switch (also known as “tamper switch”), water level indicator, or low-air pressure switch on a dry-pipe system that triggers a supervisory signal.

**TESTING** - A procedure used to determine the status of a system as intended by conducting periodic physical checks on water based fire protection systems such as water flow tests, fire pump tests, alarm tests, and trip tests of dry pipe or deluge valves. These

tests follow the requirements for acceptance testing at intervals specified in the appropriate chapter of NFPA 25, 2011 edition.

**WATER HAMMER** - The surge in pressure when a high-velocity flow of water is abruptly shut off. The pressure exerted by the flowing water against a closed system can be seven or more times that of the static pressure.

**WATER SPRAY** - Water in a form having a predetermined pattern, particle size, velocity, and density discharge from specially designed nozzles or devices.

**WATER SUPPLY** - A source of water that provides the flows [gal/min (L/min)] and pressures [psi (bar)] required by the water-based fire protection system.

**WATER TANK** - A tank supplying water for water-based fire protection systems.

**WET STANDPIPE SYSTEM** - A standpipe system having piping containing water at all times.



## **PART 7: DIFFERENT TYPES OF STANDPIPE SYSTEMS**

### **7.1 OVERVIEW OF STANDPIPE SYSTEMS**

Standpipe systems are an important part of the fire protection system in a building. The standpipe system provides water that fire fighters can manually discharge through hoses onto a fire. The water is fed into a piping system. The piping runs vertically (up and down) and horizontally (side to side) throughout the building. The piping running vertically is usually called a riser. Risers are usually located in the staircase enclosures or in the hallways in the building. This piping system supplies water to every floor in the building. When a standpipe system is installed and properly maintained it is a very effective mean for extinguishing fires. A typical standpipe system is shown in the illustration on the right.

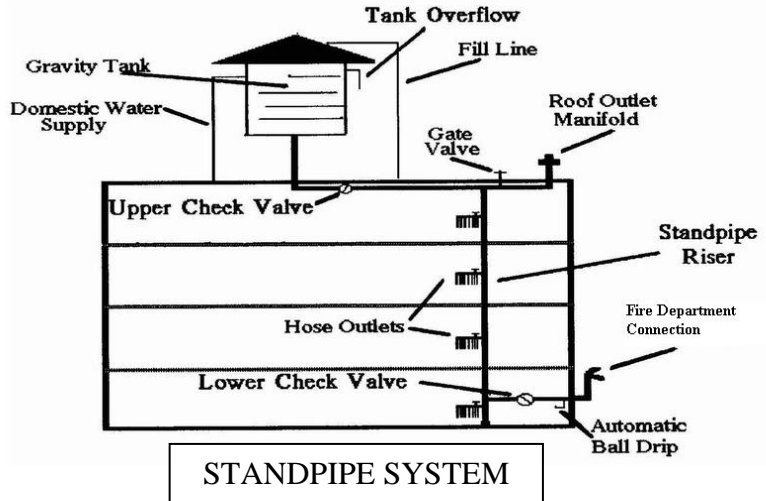

Multi-zone system is a standpipe system that is vertically subdivided as required by the construction codes, into zones to limit the maximum operating pressure in the system. Each zone will have its own individual automatic water supply. Standpipe zone heights are limited to 300 feet. All zones serving occupied floors located higher than 300 ft. shall be provided with primary and auxiliary water supplies. For example, a 50-story building may have a low zone ranging from the first floor to the 25th floor. A fire pump on the first floor supplies floors 1 to 25; a fire pump on the 25th floor supplies water from the 26th floor to the roof. Each zone may have its own Fire Department Connections. The design of the multi-zone systems varies from building to building. The S-14 Certificate of Fitness holder must be familiar with the system design and must be immediately available to assist the Fire Department in the operation of the system in the event of a fire.



(The left Fire Department Connection in the photo is to cover the lower zone and the right Fire Department Connection is to cover the higher zone.)

## **7.2 CLASSES OF STANDPIPES SYSTEMS**

Standpipe systems are classified depending on who is expected to use the system. The 3 classes are briefly described below:

**Class I:** This system is designed to be used by Fire Department and Fire Brigade personnel. The fire hoses in these systems are 2 1/2 inches in diameter. The large hose diameter makes it difficult to control the stream of water from the hose.

**Class II:** This system is designed to be used by the occupants of a building. The hose and nozzle are connected to the standpipe. They are ready to be used by occupants in case of a fire. The hose is 1-1/2 inches in diameter. The hose stream is easier to control than the Class I hose.

**Class III:** A system that provides 1-1/2 in. hose stations to supply water for use by trained personnel and 2-1/2 in. hose connections to supply a larger volume of water for use by Fire Departments.

## **7.3 WET (AUTOMATIC) STANDPIPE SYSTEM**

This system always has water in the piping. The water in the system is always under pressure. In some cases a fire pump may be used to increase the water pressure. The wet standpipe system is the most commonly used standpipe system. It is used in heated buildings where there is no danger of the water in the piping freezing. Any part of the standpipe system that is exposed to freezing temperatures should be insulated. It is very important that the water in the piping does not freeze. Frozen water may prevent the standpipe system from working.

## **7.4 WET (MANUAL) STANDPIPE SYSTEM**

A manual wet standpipe system is a type of a wet standpipe system that is connected to a small water supply for the purpose of maintaining water within the system or sharing a water supply with an automatic sprinkler system, but not having a water supply capable of delivering the system demand required for the system.

## **7.5 DRY (AUTOMATIC) STANDPIPE WITH AN AUTOMATIC DRY PIPE VALVE**

This system is usually supplied by a public water main. Under normal conditions there is no water in the piping. Instead, there is air under pressure in the piping. A dry pipe valve is installed to prevent water from entering the standpipe system. The dry pipe valve is designed to open when there is drop of air pressure in the standpipe. When a hose is opened it causes a drop in air pressure in the standpipe system. Then the dry pipe valve automatically lets water flow into the standpipe. A control valve is installed at the automatic water supply connection. This valve should be kept open at all times to supply the standpipe system. This system is usually installed in a building that is not heated. The air pressure is usually set at 15 to 20 psi (pounds per square inch) above the normal trip level. Some valves are specially designed for low pressures. In all cases the manufacturer's instructions regarding pressures to be maintained shall be followed. A drop of pressure in the piping will cause the clapper to open, when that happens the valve is said to have tripped.

Quick opening devices are used to reduce the time needed to open the clapper and allow water into the system. These devices are an accelerator and an exhaustor. They are both

automatically activated when a drop of 2 psi in air pressure is detected in the system. They quickly change the water and air pressure balance in the system. This change trips the dry pipe valve allowing the water to force its way through the sprinkler piping in less time. The failure of an accelerator or exhaustor to operate will increase the normal tripping of a dry pipe valve.

#### **7.6 DRY (MANUAL) STANDPIPE WITH A MANUAL CONTROL VALVE**

This system is supplied by a public water main. Under normal conditions this system has no water in the piping. The water is not allowed into the standpipe until a control valve is manually operated. The control valve remains closed until a fire occurs. The air in the piping is not under pressure. This system is usually used in a building that is not heated.

#### **7.7 DRY (MANUAL) STANDPIPE WITH NO PERMANENT WATER SUPPLY**

Under normal conditions this system has no water in the piping. Water is pumped into the standpipe system by the Fire Department. The water is pumped in through the Fire Department connection. This system cannot be used unless water is supplied by the Fire Department. A sign must be attached to each of the hose outlets. It should read "Dry Standpipe for Fire Department Use Only". This system is usually used in a building that is not heated such as unoccupied buildings and parking garage structures. Special care must be taken when using a dry standpipe system. The nozzle must never be pointed at the fire until all of the air has been drained from the system. Otherwise, pressurized air would be discharged onto the fire. This would cause the fire to burn more intensely.

#### **7.8 SEMIAUTOMATIC DRY STANDPIPE SYSTEM**

A standpipe system permanently attached to a water supply that is capable of supplying the system demand at all times arranged through the use of a device such as a deluge valve and that requires activation of a remote control device to provide water at hose connections.

#### **7.9 YARD SYSTEMS**

A yard hydrant system is most often used in large private manufacturing plants or storage buildings. The yard system is often needed because the public water supply does not meet the needs of the fire protection system. The yard system usually has several private water sources supplying the total fire protection system. The total system may have a sprinkler system, hydrants, and a standpipe and hose system installed.

The water supply sources are all connected together in the yard system. This allows the water to be directly supplied to any part of the system when needed. Water can be supplied even when one of the supply sources is not working. The combined sources of water keep the water pressure in the system at a high level. The picture below shows a detailed yard fire protection system.

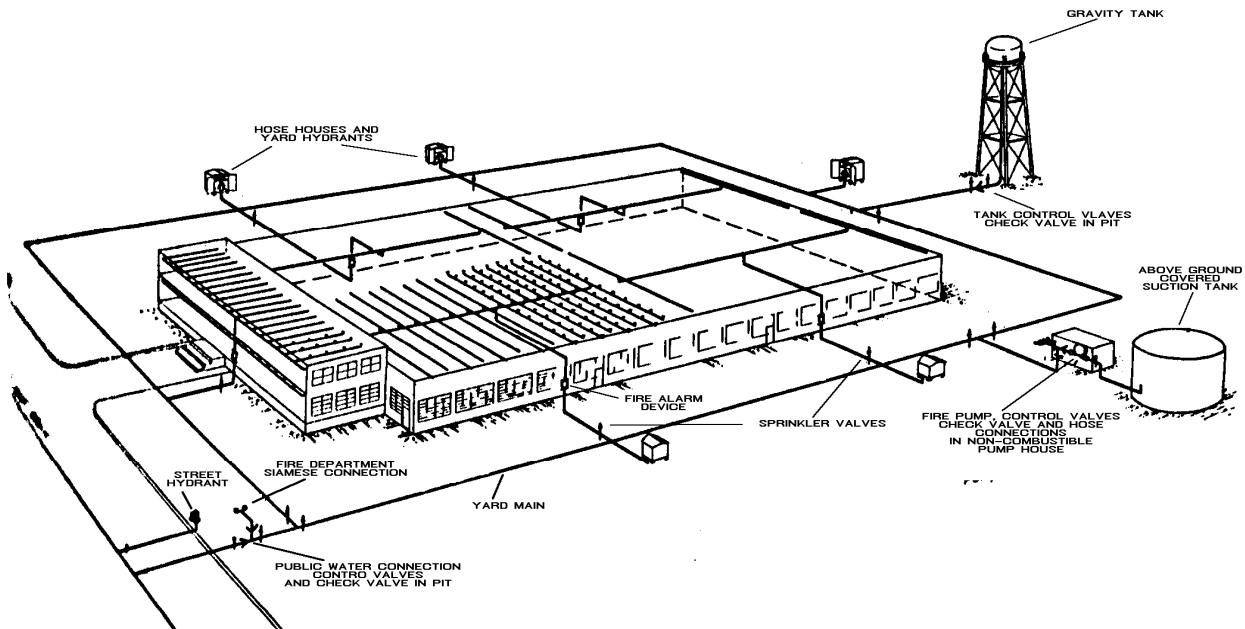

**A TYPICAL YARD FIRE PROTECTION SYSTEM**

**7.9.1 Public Waterworks Connection**

The street main supplies water using the water pressure in the public water works system. Sometimes a street main may not be connected to the system if it is located too far away from the building.

**7.9.2 Pressure Tank**

This tank may supply water to the yard system under pressure. The tank is filled with water and air. The air forces the water out under pressure when part of the fire protection system is activated.

The water supply sources are all connected to a main water supply grid. This supply grid surrounds the entire building. Control valves are installed at various locations on the system. These valves are called post indicator valves (PIV). As the name suggests they indicate the position of the valve using a target that is visible through a window on the valve body. The valves are manually operated. Under normal conditions the PIV are sealed open. The PIV allow the Fire Department to shut down all or part of the system. The PIV are also used to shut down parts of the system when conducting repairs and maintenance. A typical PIV is shown on the right.

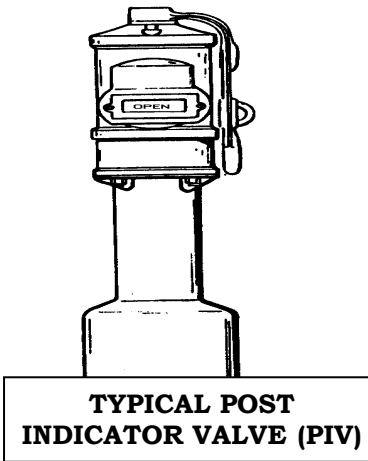

The water in the yard system is not allowed to flow into the public water system. It is prevented from doing so by a check valve.

Several supervisory and alarm devices are usually installed in the yard system. They indicate when there is a problem with the equipment. They also indicate when water flows through the yard system. These devices are needed to make sure that the system will work properly in case of a fire. The supervisory devices may be connected to a central station company. The central station company is automatically notified when there is any problem with the yard system. It will then notify the local fire house. When Post Indicator Valves (PIV) are installed in yard systems they shall be painted red.

Hydrants may be installed on some yard systems. They allow the Fire Department to run hoses from the private water mains. The location of the hydrants will depend on the layout of the building yard's supply system.

### **7.10 COMBINATION / COMBINED SYSTEMS**

It is not uncommon to find occupancies having a combination of systems for fire protection.

#### **Examples of combination systems:**

- a. Combination System (WET STANDPIPE AND DRY STANDPIPE)
- b. Combined System (WET STANDPIPE SYSTEM AND AUTOMATIC SPRINKLER SYSTEM) – A standpipe system having piping that supplies both hose connections and automatic sprinklers. Each connection from a standpipe that is part of a combined system to a sprinkler system shall have an individual control valve and check valve of the same size as the connection.

### **7.11 PREACTION STANDPIPE SYSTEMS**

Preaction systems are designed for situations where there is danger of serious water damage. Water damage is usually caused by damaged standpipe piping. Under normal conditions there is no water in the piping. The air in the piping may or may not be under pressure. A preaction valve prevents the water from entering the system. The valve is automatically opened when an electrical or hydraulic release is manually activated.

Alarms are standard accessory equipment on preaction valves. They provide an audible signal in the building if the valve operates for any reason. The alarm is annunciated if a problem is discovered with the equipment. The alarms can send a signal to central station company or a public fire alarm system. Often the signal is sent to both the central station company and the public alarm.

## **PART 8: STANDPIPE SYSTEM COMPONENTS**

---

### **8.1 ROOF MANIFOLD**

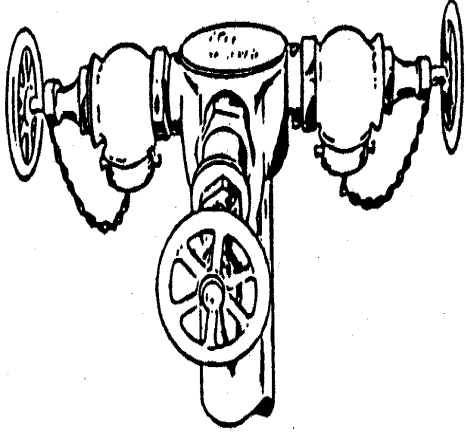

Standpipe systems are used in buildings where it may be difficult for the Fire Department to pump water on the fire. For example, standpipe systems are required in buildings that are over six stories (75 feet) in height. A standpipe system may be combined with an automatic fire protection system. For example, a standpipe system and a sprinkler system may be installed in the same building. The standpipe and the sprinkler systems may even share the same water supply and riser piping. The top of the standpipe riser extends up onto the roof. Three hose connections are attached to the top of the standpipe riser. These three connections make up the roof manifold. The roof manifold is used when extinguishing fires on the roof or adjacent buildings. It is also used when testing the water flow in the standpipe.

At the top of the highest riser there shall be provided, above the main roof level, a three way manifold equipped with three 2-1/2 in. hose valves with hose valve caps. The manifold may be set in a horizontal or vertical position, provided the hose outlets are set back between 18 in. and 60 in. above the roof level.

### **8.2 FIRE DEPARTMENT CONNECTION**

For automatic standpipe systems, a connection through which the Fire Department can pump supplemental water into the sprinkler, standpipe or other system furnishing water for the fire extinguishment to supplement existing water supplies.

For manual standpipe systems, a connection through which the Fire Department can pump the primary water supply to the manual standpipe system at the required system demand.

A Fire Department connection is always installed on the system. The connection is used by the Fire Department to pump water into the standpipe system. Fire Department connections must always be accessible. Each connection shall be equipped with a check valve. An auxiliary source of water supply for standpipe systems includes manually activated fire pumps or Fire Department connections.

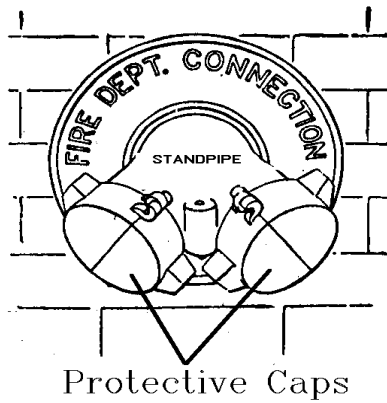

**FIRE DEPARTMENT CONNECTIONS**

A pressure restricting device shall be installed at each hose outlets where required by the installation standard NFPA 14 and the NYC Building Code. The floor location and pressure setting must be marked on the device. An occupant of the building may be injured if a hose is used when the pressure restricting device is not installed. The pressure restricting device may be adjusted or removed by Fire Department personnel during an emergency.

**STANDPIPE VALVE WITH CAP AND A CHAIN**



In some occupancies, only a hose valve is installed in lieu of both a hose valve and hose. The Fire Department attaches its own hose to this connection when fighting a fire.

### **FIRE DEPARTMENT CONNECTION TO A STANDPIPE RISER**

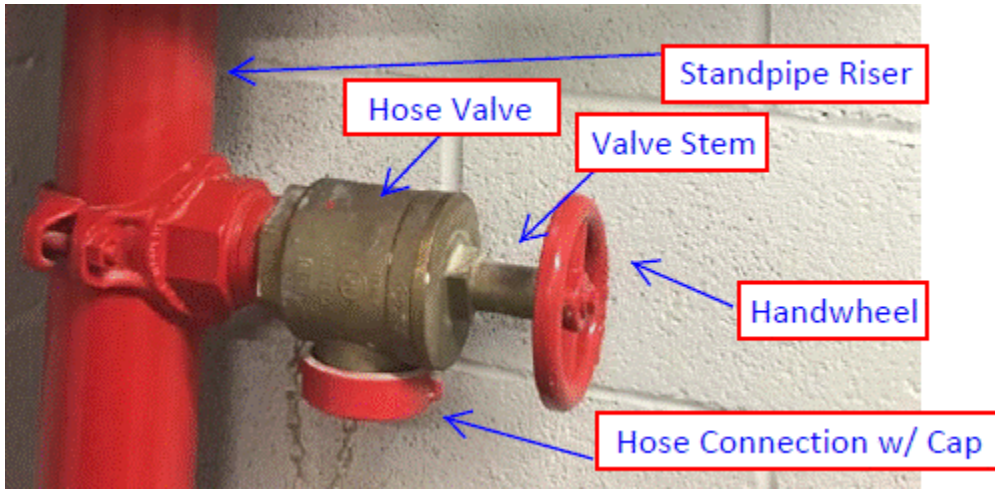

Each standpipe system may also be fitted with a drain valve. The drain valve is located at the lowest point on the standpipe system. The drain valve is used when the standpipe system has been used, tested, or repaired. Cross connections and standpipe risers must be red in color.

The automatic ball drip device between the check valve and the outside hose coupling on the Fire Department connection prevents water from building up in the piping. An automatic ball drip on a standpipe Fire Department connection that leaks is an indication that the check valve is defective. This drip device makes sure that the Fire Department connection is not blocked by water which has frozen in the piping. If water freezes in the piping, the Fire Department will not be able to pump into the system.

### **8.3 ALARMS AND SUPERVISORY SIGNAL DEVICES**

Supervisory devices are often connected to a central station company which monitors the sprinkler/standpipe system for problems with equipment and when standpipe hoses have been activated. In order to reduce the number of unwarranted alarms it is important that the central monitoring station is notified when any of the control valves are closed for maintenance or repair of the sprinkler system.

Standpipe systems are designed with built-in alarm devices. The most appropriate course of action to take when one of these devices is activated is to respond to the fire alarm panel.

#### **8.3.1 Devices and Equipment Supervised**

Standpipe system supervision is commonly provided for:

- (1) water supply control valves;
- (2) low water level in water supply tanks;
- (3) low temperature in water supply tanks or ground level reservoirs;
- (4) high or low water level in pressure tanks;
- (5) high or low air pressure in pressure tanks;
- (6) high or low air pressure in dry pipe systems;
- (7) failure of electric power supply to fire pumps;



- (8) automatic operation of fire pumps, and
- (9) fire detection devices used in conjunction with deluge and/or pre action systems.

### **8.3.2 Water Flow Alarms**

Water flow alarms and fire alarms give warning of the actual occurrence of a fire or other conditions such as broken piping. Alarms alert occupants and summon the Fire Department. Any signal, whether water flow or supervisory, may be used to give an audible local alarm. It may also send a signal to a central station company. The central station company will then contact the Fire Department.

Water operated alarm devices must be located near the alarm valve, dry pipe valve, or other water control valves in order to avoid long runs of connecting pipe.

### **8.3.3 Pressure Tank Alarms**

All pressure tanks used to provide the required primary water supply of a standpipe system shall be equipped with a high and low air pressure, and a high and low water level electrical alarm system. This alarm system automatically annunciates the condition of the air-to-water ratio which should always be 1 to 2. However, when the water level or the air pressure falls below acceptable levels, an alarm signal is transmitted that there is a problem with the pressure tank.

### **8.3.4 Alarm Retarding Devices**

An alarm check valve that is exposed to changing water supply pressure needs an alarm-retarding device. This is required to prevent unwarranted alarms when the check valve clapper is lifted from its seat by a temporary pressure surge.

## **8.4 DIFFERENT TYPES OF VALVES**

### **8.4.1 Check Valves**

A check valve is a type of valve which only permits flow in one direction. These valves are often designed for safety reasons; to prevent backflow and to ensure that someone operating a system knows which direction water is flowing in.



### **8.4.2 Swing Check Valves**

This is a type of check valve that allows full, unobstructed flow and automatically closes as the pressure decreases. These valves are fully closed when the flow reaches zero and prevent backflow. A swing check valve is normally used in systems using a gate valve because of the low pressure drop across the valve.

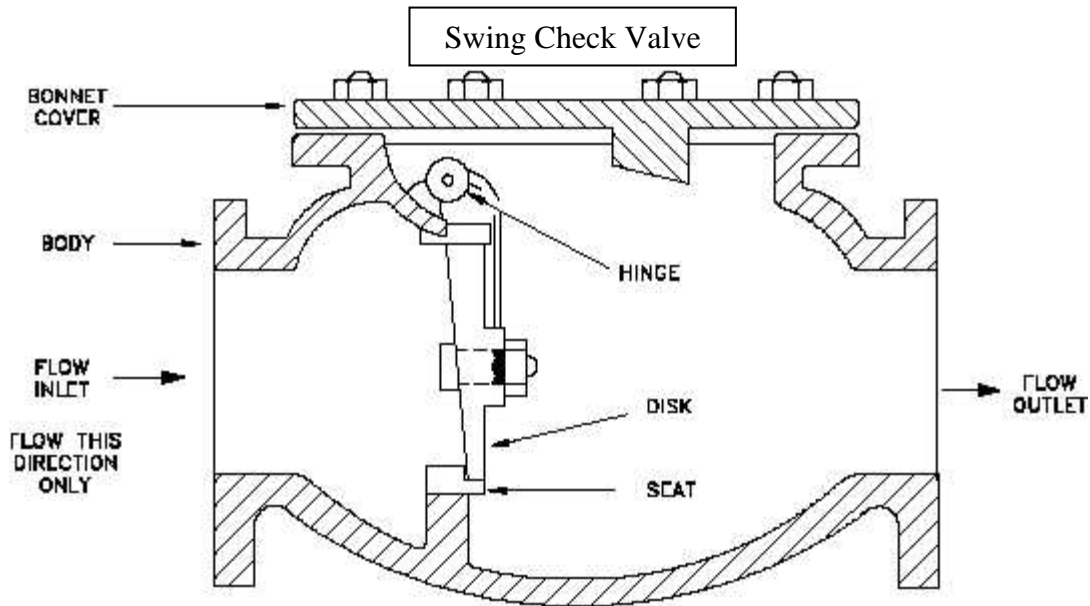

### 8.4.3 Alarm Check Valves

The basic design of most alarm check valves is that of a check valve which lifts from its seat when water flows into a standpipe system. These alarm attachments are designed to initiate an alarm by a drop in water pressure in the standpipe system. The alarm signals the occupants of the building that the standpipe/sprinkler system has been activated.

### 8.4.4 Curb Valves (Non-Rising Stem)

Curb valves are non-indicating type of gate valves and are provided in water distribution systems to allow for segments of the standpipe system to be shut off for repairs or maintenance without reducing protection over a wide area. Such valves which require a special key wrench to operate. A valve box is located over the valve to keep dirt from the valve and to provide a convenient access point for the valve wrench to the valve nut. A complete record should be made for each valve in the system, including date of installation make, direction of opening, number of turns to open, any maintenance performed.

### 8.4.5 OS & Y (Outside Screw and Yoke)

OS&Y (Outside Screw and Yoke) gate valves are installed at several places in the system. The OS&Y valves are found just inside the building wall on the main riser, or outside in protected pits. The OS&Y valves can be used to shut down just a part of the standpipe system. Sections may be shut down when fighting a fire. Sections are also shut down for testing, repairs or maintenance. It is easy to tell if the OS&Y valve is in the open or closed position. If the stem is raised (OUT), above the control wheel the valve is open. If the stem is flushed (IN) with the control wheel the valve is closed. A typical OS&Y gate valve is shown on the following page. (The valve in the image is open.)

### O S & Y valve

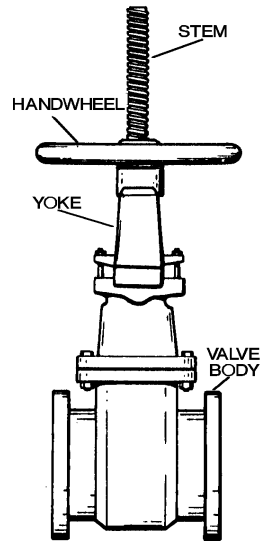

## **8.5 FIRE HOSE INCLUDING COUPLINGS AND NOZZLES**

The care, use and service testing of these components must comply with the standard of NFPA 25, 2011 edition and NFPA 1962, 2008 edition in order to provide safety for users that the component will perform as required.

### **8.5.1 Fire Hose Outlet and Release Rack**

At selected locations in the building the piping is connected to a hose. These connections are controlled by hose valves. No water is allowed into the hose until the valve is opened. The fire hose valve shall only be operated by the FDNY. The hose is usually stored on a quick release rack. The hose at each outlet shall be kept upon a hose rack firmly supported and placed between 5 ft. and 6 ft. above the floor or landing. Hose valve shall not be operated for normal testing and maintenance procedure.

### **A TYPICAL FIRE HOSE OUTLET AND RELEASE RACK**

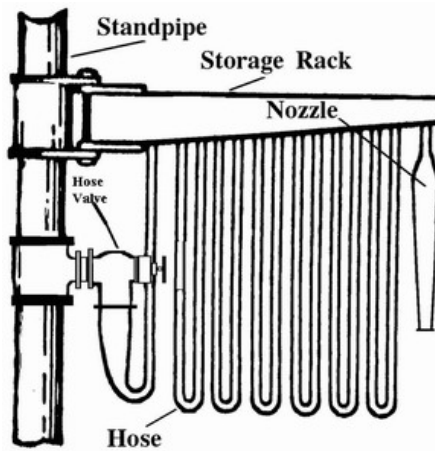

Inclined hose racks are often used, as most existing stations can accommodate such racks. The racks should be located where the sun or excessive heat will not damage the hose. The rack has the advantage of allowing the hose to drain internally while providing a drying area from which fire fighters can easily load and unload a hose.

### 8.5.2 Hose Cabinets and Storage

**CABINET EQUIPMENT IDENTIFICATION** - Cabinets shall be identified in an approved manner by a permanently attached sign with white letters not less than 2 inches (51 mm) high and a contrasting red background color, indicating the equipment contained therein.

**Exception** - Doors that have either an approved visual identification clear glass panel or a complete glass door panel are not required to be marked.



**Hose Cabinet**

Locking of cabinets shall be permitted in Institutional Group-3. Cabinets containing fire-fighting equipment such as standpipes, fire hoses, fire extinguishers or Fire Department valves shall not be blocked from use or obscured from view. Hose valves are capped with a hose valve cap fastened to the valve with a chain.

**STORAGE** - Hose in storage shall be kept out of direct sunlight and in well-ventilated location. Hose shall be stored only after it has been properly inspected, service-tested if required, cleaned, dried and rolled. Hose that is out-of-service for repair shall be properly tagged and kept separated from any hose that is in storage and ready for service. To maximize life of hose, it should be stored in a ventilated area at temperatures between 32°F and 100°F (0°C and 38°C).

**HOSE HOUSES** - Hose houses may be installed on the system. The hose house must be painted red. The house is usually located outside the main water supply grid. The house must be accessible at all times. Hoses, nozzles and other fire protection tools are kept in the hose house. Standpipe connections are located in the hose house. These connections allow the fire fighters to connect directly into the yard system. They are very helpful when the street mains are located too far away from the building. The connections save a lot of time when fighting a fire. Hose outlet valves are painted red. Riser control valve servicing house outlet valves on a standpipe system are required to be painted red as well.

### 8.5.3 Nozzles

#### **DISCHARGE DEVICE**

A device designed to discharge water in predetermined, fixed, or adjustable pattern. Examples include, but are not limited to: spray nozzles, and hose nozzles. Nozzles on 2 1/2 in. hose, except for yard hydrants, shall be at least 15 in. in length, and shall have a smooth bore with a 1 in. or 1-1/8 in. discharge orifice.

A nozzle is attached at the end of the hose. The nozzle is used to direct the stream of water from the hose. Nozzles at auxiliary hose stations shall be Fire Department approved adjustable combination fog nozzles.



The hose and nozzle must be easy to reach at all times. The hose outlets are located so that every part of the building may be reached with a hose stream. The maximum length of a single hose line is 125 feet. If the hoses are installed in cabinets each cabinet should be labeled "FIRE HOSE". When the hose outlets are not easy to see, signs should be posted telling where the hose outlets are located. Nozzle valves attached to in-service hose shall be kept in the closed position.

#### **8.5.4 Hose Records (Occupant-Use Hose)**

Accurate hose records shall be maintained. Records are essential and necessary data to determine hose performance and ensure safe use in firefighting. Cost effectiveness can also be determined.

Each length of hose shall be assigned an identification number for use in recording its history throughout its service life. The identification number shall be stenciled on the jacket or covered using an ink or paint that is not harmful to the hose. The identification number shall be permitted to be stamped on the bowl or swivel of the female coupling in a manner that prevents damage to the coupling. Where hose repairs are frequent, however, couplings and hose lengths can become intermingled so that either stenciling the hose or changing the couplings should be employed. In stamping couplings, the proper procedure is to insert a special steel plug with round edges into end of the expansion ring. One sharp blow from a steel numbering die will then clearly stamp the coupling. Coupling bowls can be damaged by improper stamping. Aluminum couplings should be stamped before they are hard coated. Some fire departments color code couplings as well as various tools to identify the company to which the equipment is assigned to. This enables each company to readily identify and pick up its hose and equipment at a fire. Where mutual aid operations are frequent, each length of hose should be appropriately stenciled or marked with the identification. A water-based latex paint is not harmful to hose. Paints with a petroleum solvent base can cause the bond between the liner and jacket to fail.

Records of hoses used by the Fire Departments shall be kept as part of the Fire Departments complete equipment inventory. Conditions, repairs, changes and problems shall be recorded immediately for each length of hose.

### Hose Record Card

<b>Size (dia.)</b> _____	<b>Length</b> _____	<b>Type Hose</b> _____	<b>Date in service</b> _____
<b>Date Mfg</b> _____		<b>Type of Couplings:</b> <u>Female/Male</u>	
=====Repairs=====			
<b>Date</b>	<b>Condition</b>	<b>New Length</b>	<b>ID no.</b>
<b>Location of ID#</b>	_____	_____	_____
_____	_____	_____	_____
_____	_____	_____	_____
_____	_____	_____	_____
_____	_____	_____	_____
_____	_____	_____	_____
<b>Remarks:</b> _____			
_____			
_____			

### Test Record

<b>Service test to</b> _____ <b>psi</b>							
<u>Date</u>	<u>Service Test press res. Psi</u>	<u>Test OK</u>	<u>Reason Failed</u>	<u>Date</u>	<u>Service test pres. psi</u>	<u>Test OK</u>	<u>Reason Failed</u>
<u>Date</u>	<u>Exposed to possible damage</u>			<u>Date</u>	<u>Reason</u>		
		<b>Removed from service</b>					
		<b>Condemned</b>					
		<b>Sold</b>					
		<b>Wrnty. failure</b>					

Records for hose on racks or reels or in enclosures shall be kept at the hose location or at a control location on the premises where the hose is located.

**THE FOLLOWING INFORMATION SHALL BE INCLUDED FOR EACH HOSE:**

- a. Assigned Identification number
- b. Manufacturer and part number
- c. Vendor
- d. Size (internal diameter of waterway)
- e. Length

- f.** Type of hose
- g.** Construction
- h.** Date received and date put in service
- i.** Date of each service test and the service test pressure
- j.** Repairs and new length if shortened
- k.** Actual damage
- l.** Exposure to possible damage
- m.** Reason removed from service
- n.** Reason condemned
- o.** Indication that the hose has been removed from service or condemned with the warranty period because of an in-warranty failure.

Other information recorded may include coupling threads, manufacturer of coupling and part number, length of guarantee, label number, and cost.

Out-of-service hose shall be properly tagged with reason for removal from service noted on the tag.

#### **8.5.5 Occupant-Use hose**

Occupant-use shall be service-tested within 90 days prior to being put in service. Service testing of hose is to ensure its suitability for continued use. For unlined standpipe with trade size (1½ in. – 2½ in.) single jacket hose the acceptable service test pressure is 150 psi.

**PART 9: WATER SUPPLY**

Standpipe systems may be supplied from one, or a combination of sources. For example, they may be supplied by public mains, gravity tanks, pressure tanks, reservoirs, rivers, or lakes. A single water supply would appear to be all that is needed to supply a standpipe fire protection system. This assumes that there is enough water at an acceptable pressure. However, there are a few reasons why it is good to have a second water supply source. These reasons include, but are not limited to:

1. A single supply source may be out of service (for maintenance or repair) during a fire emergency;
2. A single supply source may be disabled during a fire, or before the fire is fully extinguished;
3. The water supply source may fall below normal pressure or volume during an emergency.

**9.1 Pressure Tanks**

Pressure tanks are enclosed water tanks of limited size. Air pressure in the tank permits forceful discharge of water from the tank into the standpipe system. A pressure tank may be used as a primary or secondary water supply for a standpipe system. A pressure tank is usually housed in an enclosed structure. The temperature in the enclosure is kept at 40° Fahrenheit or above. The heated structure may be located anywhere in the building or even outside the building. Pressure tanks shall be maintained two-thirds full of water and one-third full of pressurized air. The acceptable air pressure inside the tank may vary from 15 psi to 80 psi, as per the Department of Buildings (DOB) rules and regulations. The air compressor shall be provided with automatic controls for maintaining the air pressure. The capacity of the compressor shall be sufficient to build up the tank pressure to 75 psig within 3 hours or less.

Pressure tanks shall be provided with approved closed circuit high and low water alarms. Pressure tanks shall be located at or above the top level of sprinklers.

The air pressure in the tank is automatically maintained by an air compressor. The maximum capacity of pressure tanks is typically 9,000 gallons. Some standpipe systems require more than 9,000 gallons of water. If necessary, several pressure tanks can be used in combination to supply the system. A sectional view of a standard pressure tank is shown in the diagram on the right.

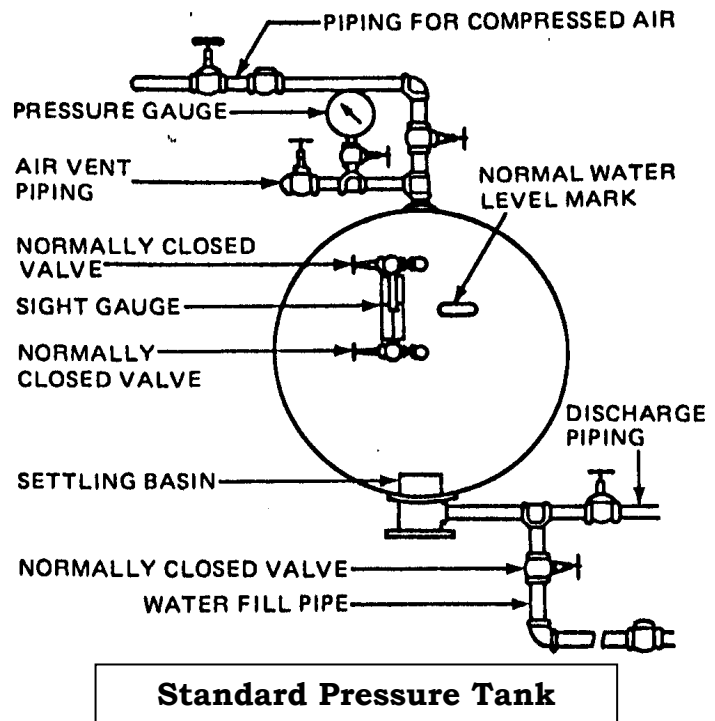



### 9.1.1 Pressure Tank Alarms

All pressure tanks used to provide the required primary water supply of a standpipe system should be equipped with two high and low alarm systems. One system monitors the high and low air pressure. The other system monitors the high and low water levels. The alarm system automatically monitors the air-to-water ratio which should always be 1/3rd (air) to 2/3rd (water). An alarm (high-low) or supervisory signals will annunciate when the water level or the air pressure falls too low. When this happens the pressure tank shall be adjusted or repaired immediately.

### 9.1.2 Supervision of the Pressure Tank

The pressure tank may also be supervised by an approved central station company, which monitors the standpipe system. Supervisory devices alert the central station company when there is a problem with the tank's water level, air pressure, or water temperature. These devices also alert the central station company when water has been discharged from the tank. When water has been discharged through a hose outlet or a sprinkler head the FDNY Borough Dispatcher shall be notified.

The central station company notifies the building owner when an alarm or supervisory signal is transmitted. It is required that the pressure tank is returned to good working order immediately.

The water gauge valve must be opened to examine the water level as shown in the sectional diagram on the right.

When the valve is opened the water will flow into the gauge. This allows the C of F holder to compare the water level in the tank to the desired water level mark. Adjustments to the water level shall be made as needed by an authorized individual. After visually inspecting the water gauge valve, the valve shall be closed.

When the valve is closed, the water and air in the tank are isolated from the sight glass. If the gauge glass breaks the volume of water and the air pressure are not affected.

The inside of pressure tanks shall be inspected every three years. The inside of the tank shall be maintained free of rust and foreign materials.

The temperature inside the structure that houses the pressure tank shall be maintained during cold weather to ensure that the temperature is at a minimum of 40° Fahrenheit at all times.

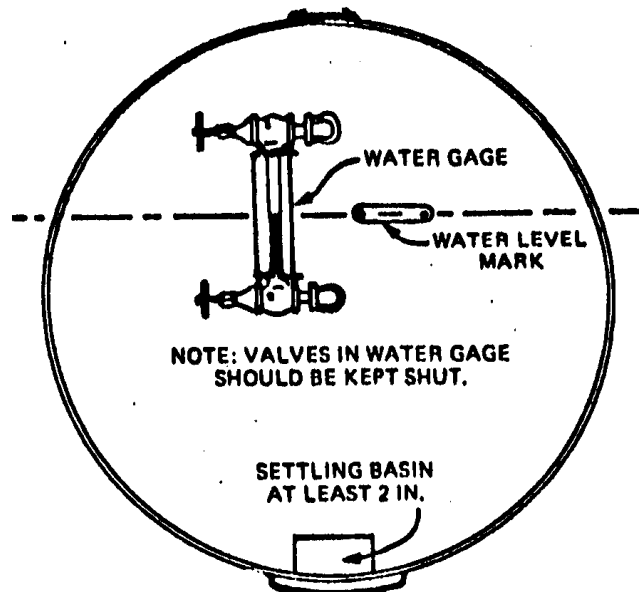

## 9.2 Gravity Tanks

The gravity tank supplies water using the force of gravity. Gravity tanks are used for water storage. They are made of wood, steel, concrete or other approved material. Gravity tanks are used as a primary or secondary water supply source for standpipe systems. A gravity tank delivers water to the standpipe system without the use of pumping equipment. A gravity tank shall be at least 25 feet above the highest

standpipe hose outlet that it supplies. Tanks may be located on the tops of buildings or raised on tall supporting towers. A gravity feed standpipe system distributes water throughout the fire protection piping without the use of pumping equipment.



**AN EXAMPLE OF A TYPICAL GRAVITY TANK**

The water pressure in a gravity tank system depends on the elevation of the tank. This is a major advantage over other kinds of systems. For every 1 foot the tank is above the discharge outlet, an additional 0.433 psi of water pressure is achieved. For example a tank elevated at 100 ft. above the discharge outlet will produce a pressure of 43.3 psi.

Automatic fill pumps supply the water to most gravity tanks. The pumps shall fill the tank at a rate of a minimum of 65 gpm (gallons per minute). Two floats control the amount of water in the tank. The floats turn on the fill pump when the water in the tank is too low. The floats shut off the pump when the desired water level is reached. The floats make sure the gravity tank always has the right amount of water to supply the standpipe system. All gravity tanks have an overflow pipe that drains off too much water in the tank. This happens if the floats do not turn off the fill pump. A fill

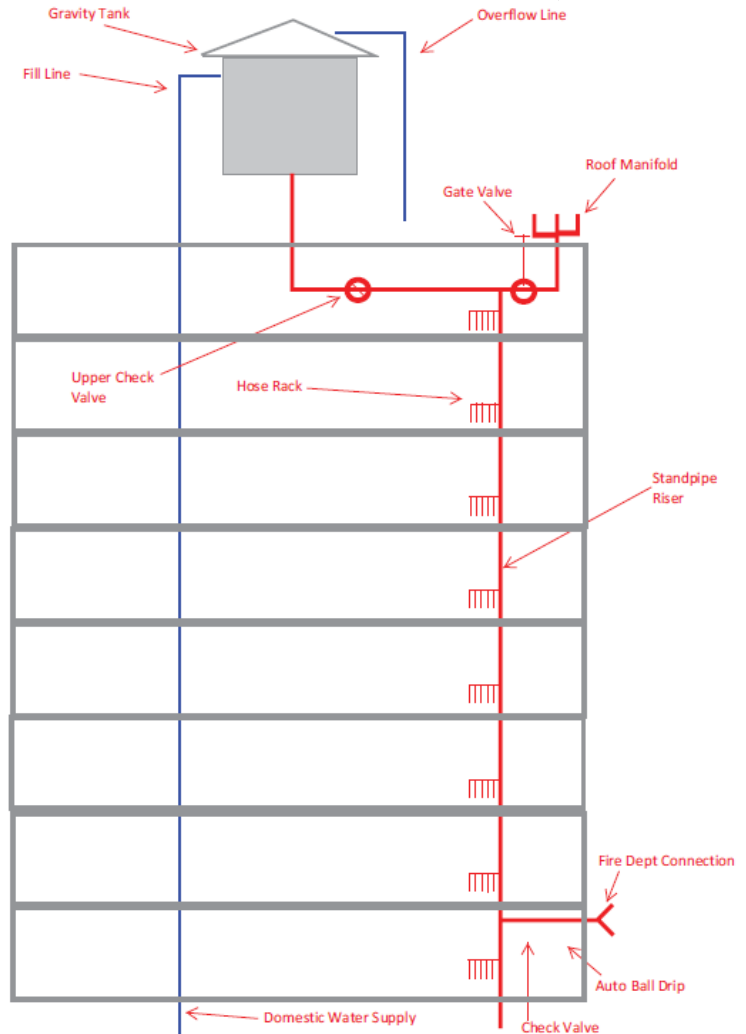
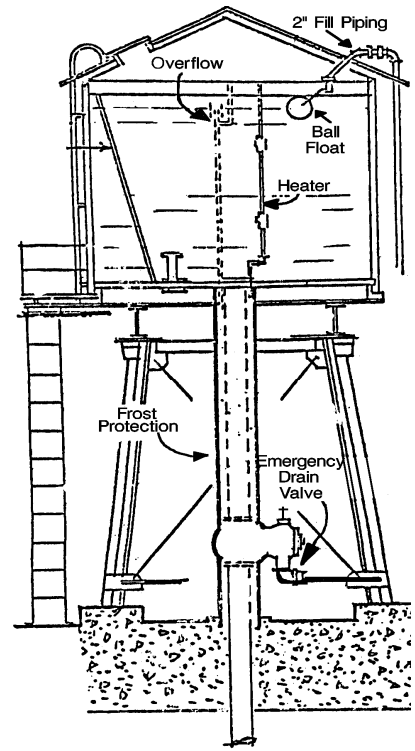

pump is not necessary if the water pressure in the city water main is able to keep the tank filled with the right amount of water.

Gravity tanks are exposed to very low temperatures. All parts of the gravity tank must be insulated or heated to keep the water from freezing. Several methods are used to heat the tank and the pipe that supplies the water. **(1)** Hot water is circulated by gravity. **(2)** Steam is discharged directly into tank. **(3)** Steam coils are placed inside the tanks. **(4)** Heat from the sun is used. The Certificate of Fitness holder can find out the temperature of the water by using a thermometer. The thermometer is located near the heating device. Severe damage can occur to the piping and the tank if the water inside the tank freezes. During freezing weather, the temperature of the water inside the tank and the riser must be checked daily or weekly. The temperature of the water shall always be at least 40° Fahrenheit.

Ice should not be allowed to build-up on the gravity tank. The extra weight of the ice might weaken the supports of the tank and cause the tank to collapse. Falling icicles may also cause damage or injury. It is essential to be sure that the tank is properly heated, insulated and carefully maintained.

The gravity tank shall always have a full supply of water. A full tank of water is needed to be sure the standpipe system works properly during a fire. Keeping the tank full of water also prevents wooden tanks from shrinking. A full tank of water also helps to keep steel tanks from rusting.

It is best if gravity tanks are used only for fire protection and for no other purpose. Tanks used for other purposes need to be refilled more often. The tanks become settling basins for sediment mixed in with the water. This sediment is then drawn into the piping. This may cause the standpipe system to become clogged and not work properly. The Borough Dispatcher should always be notified when a tank cannot be used for any reason. Failure of a standpipe system supplied by a gravity tank during a fire is usually caused by not enough water in the tank. The standpipe system cannot be supplied if there is not enough water in the tank. Too much water in the tank can also cause the fire protection system to fail. Too much water in the tank may cause damage due to the weight of the extra water. This could cause the gravity tank to collapse.

### **9.2.1 Gravity Tank Supervision**

The gravity tank must be constantly monitored to be sure that the tank and its parts are working. Electrical supervision devices monitor the water temperature and the water level in the gravity tank. These devices send signals to a central station company about the water level and water temperature. The central station company notifies the C of F holder when a problem with the gravity tank is detected. The C of F holder should correct the problem as soon as possible. The supervisory devices are sometimes called high and low alarms since they also send audible signals to alert the C of F holder when there is a problem.

### 9.2.3 Combination Gravity Tank and Pressure Tank Installation

Pressure tanks may be used in combination with gravity tanks to supply a standpipe system. Both tanks may be used to make sure that an adequate water supply is available. The pressure tanks also provide added water pressure to the fire protection system. An example of a combined installation is shown on the image to the right.

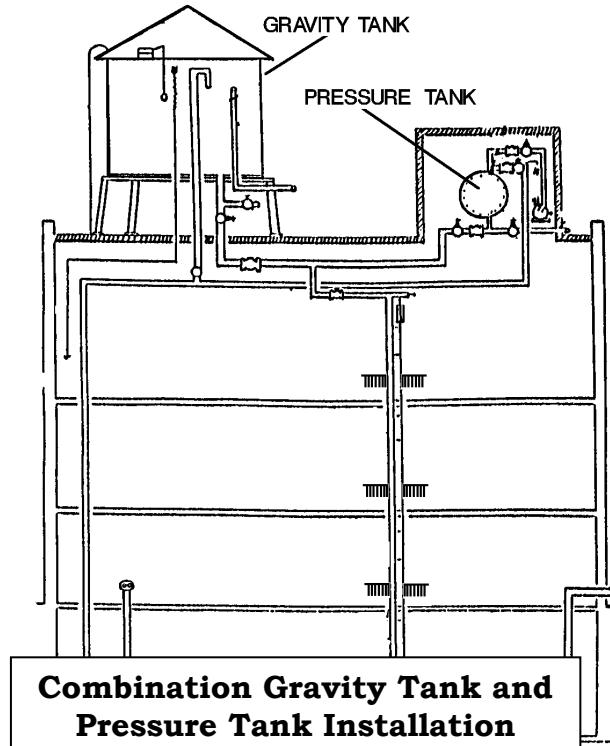

### 9.3 FIRE PUMPS

A fire pump can be used as a primary water supply source for a standpipe system. Fire Pump draws water from a suction or gravity tank and pumps it into the system when needed. Other sources of water supply for multi-zone standpipe system can be fed with gravity and/or pressure tanks to supply the system.

A fire pump is usually connected to a public water main which may be consider to be one of the most reliable water supply arrangement.

Fire pumps are designed to take the water from a supply source and then discharge the water into the standpipe system under pressure. The pressure with which the water is discharged from the pump is called the total head. The total head is usually measured in PSI. The higher the psi rating of the pump the greater the pressure with which the water can be discharged.

#### 9.3.1 The Centrifugal Pump

The centrifugal fire pump is the standard pump currently used in fire protection systems. This is the preferred pump because it is reliable, compact, requires low maintenance, and it can be powered by a variety of drivers including: electric motors, diesel engines, and steam turbines. A typical centrifugal pump is shown in the diagram on the side.

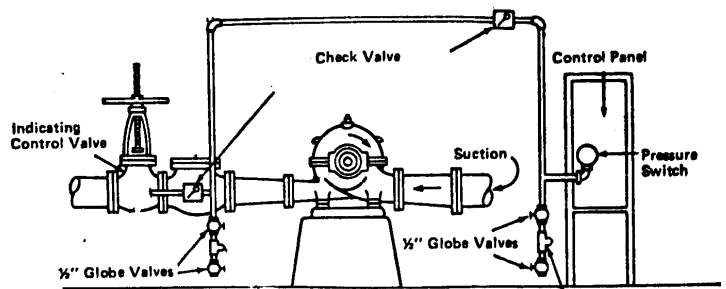

#### Centrifugal Pump Impeller

The water available to the centrifugal pump shall always be under pressure since the fire pump cannot draw water by itself from the supply source. While most pumps are supplied by municipal water mains, suction tanks may also be used for pump supplies. These

tanks must be able to provide sufficient pressure to the pump for normal operation. The water flows from the tank through the supply inlet into the pump. As the water flows through the center of the pump it passes a rotating impeller. The impeller flows the water through the inlet side of the pump. The impeller discharges the water under increased pressure through the standpipe system. Centrifugal fire pump is cooled and lubricated (while in operation) by water supplying the pump.

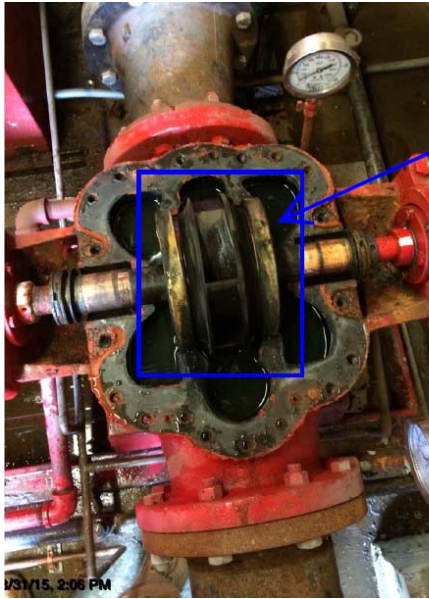

Centrifugal Fire Pumps are rated between 25 gpm (gallons per minute) up to 5000 gpm. Most centrifugal pumps have a single impeller

and are therefore commonly a single stage fire pumps. A typical centrifugal pump is shown in the picture below.

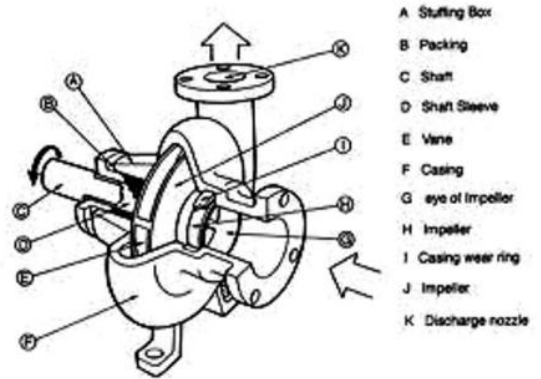

**Impeller for HP 75-100 pumps**

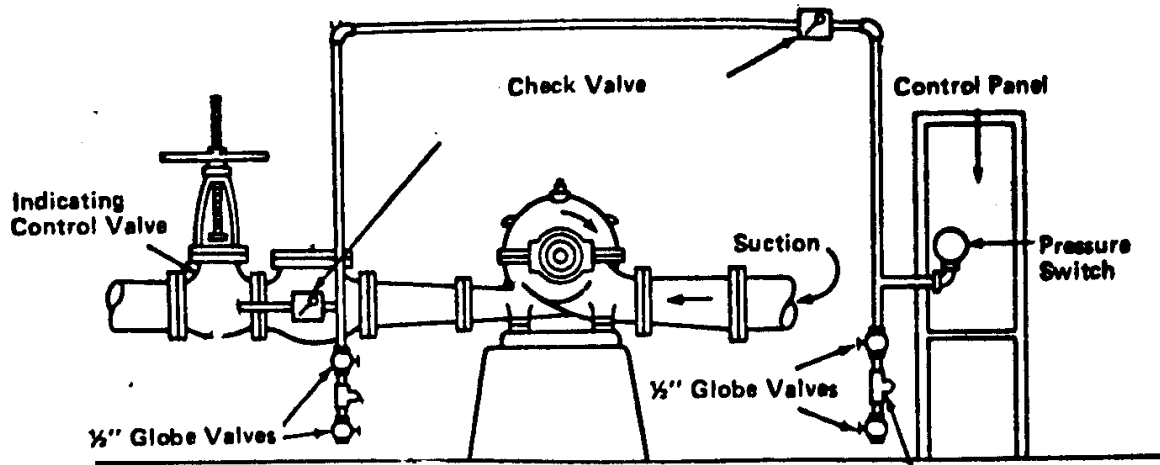

**A TYPICAL CENTRIFUGAL PUMP**

**9.4 THE VERTICAL TURBINE PUMP**

The vertical turbine pump is designed as a modified centrifugal pump that can draw water from streams, ponds, wells etc. Unlike the standardized centrifugal pump the vertical turbine pump does not required a suction supply to be under pressure for it to operate. Instead it draws the water into the pump through suction. When it reaches a

rotating impeller, the water pressure is then increased and is forcefully discharged through the fire protection system.

Although the vertical turbine pump is capable of drawing water from a well, it is generally not recommended to use a well as the main source water supply source because it may dry up without warning. Should the well dry up it would make the fire pump useless. It is better to draw from the well and to fill a water storage tank. The fire pump should then be attached to the storage tank as it is a more reliable supply source.

It is important to inspect the water intake hose, foot valve, and the strainer regularly. Mud, gravel, leaves and any other materials can obstruct a system's piping and cause damage to the pump. A vertical fire pump arrangement using a water reservoir is shown below.

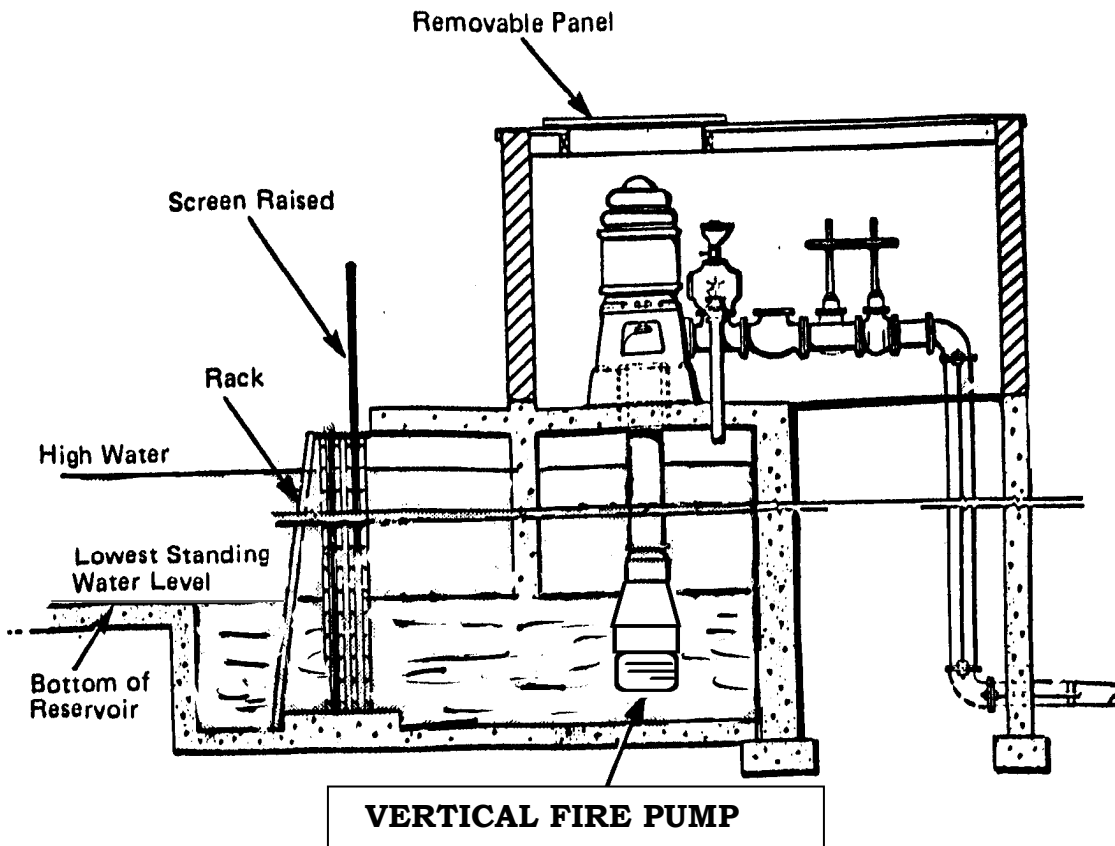

### 9.4.1 Pump Activation

A fire pump can be started automatically or manually. The pump can be started automatically by an electric controller or an engine controller. Controllers activate the pump when there is a drop in water pressure or water flow within the fire protection system. Sometimes remote push buttons are used to activate the pump. These remote push buttons are designed to start the pump but not to stop the fire pump.

Many fire pump controllers are manufactured with maximum run timers that automatically turn the fire pump OFF if an upper pressure limit has been reached. As per the FDNY Commissioner, these timers must be disabled for all automatic fire pumps in NYC.

### **9.5 PRESSURE MAINTENANCE PUMPS (JOCKEY PUMPS)**

Jockey pumps are designed to automatically or manually operate when there is a slight drop in pressure due to the leakage within the system or a pressure surge. The jockey pump restores the pressure in the fire protection system to the required level. When the drop of pressure within the system is greater than the capacity of the jockey pump, the fire pump is activated. Because this pump is considered a "convenience" pump and does not supply flow or pressure during the event of a fire, it does not require inspection, testing or maintenance as per NFPA 25 or the NYC Fire Code.

### **9.6 FIRE PUMP LOCATION**

The fire pump should be housed in a room that is fire resistant or constructed noncombustible material. The pump room should be located as close as possible to the fire protection system. The pump room should be kept clean and accessible at all times. The fire pump, driver, and controller should be protected against possible interruption of service. The temperature inside the pump room should be maintained above 40 degrees Fahrenheit at all times to prevent freezing of the water. The pump room should only be used for fire protection functions and not for general plant operations. No storage is permitted in this room.

### **9.7 OPERATION AND SUPERVISION**

When fire pumps are activated by electric automatic controllers it is essential that they are constantly monitored to ensure the availability of the electrical power supply in case of an emergency. For this reason, supervisory devices are installed on the pumps to alert the C of F holder and/or a central station company when there is an electrical power failure. In cases where the steam turbines or internal combustion engines are used similar supervisory devices are installed to signal when there is a problem with the controlling equipment.

## **PART 10: INSPECTION, TESTING AND MAINTENANCE**

---

### **10.1 A Complete Summary of Tasks Of Inspection, Testing & Maintenance**

#### **I. INSPECTION**

##### **A. Standpipe Systems:**

###### **Gauges:**

- On dry, pre-action and deluge systems shall be inspected **weekly** to ensure that normal air and water pressures is maintained;
- Where air pressure supervision is connected to a constantly attended location shall be inspected **monthly**.

###### **Alarm Devices:**

- Alarm devices shall be inspected **quarterly** to verify that they are free of physical damage.

###### **Buildings:**

- **Annually**, prior to freezing weather, buildings with wet pipe systems shall be inspected to verify that window, skylights, doors ventilators, other opening and closures, blind spaces, unused attics, stair towers, roof houses and low spaces under buildings do not expose water-filled standpipe piping to freezing and to verify that adequate heat with temperature is 40°F (4.4°C).

###### **Hanger/Seismic Braces:**

- Hangers installed in concealed space such as above suspended ceilings shall not need inspection;
- Hangers installed in areas that are inaccessible for safety considerations due to process operations shall be inspected during each scheduled shutdown;
- Hangers and braces shall be inspected **annually** from floor level to ensure they are in place, properly aligned and otherwise not damaged. All defects and deficiencies shall be corrected.

###### **Piping:**

- Piping shall be inspected **annually** from the floor level to ensure there is no mechanical damage, leakage, corrosion, misalignment and that required supports and bracing are in place and are in good condition and not missing. Nothing shall be attached to any piping system component.
- Pipe installed within concealed (such as above suspended ceilings spaces) are not required to be inspected. Exposed piping installed in areas that are inaccessible for safety considerations due to process operations shall be inspected during each scheduled shutdown.

###### **Hose Connections:**

- Hose valves shall be inspected **quarterly**. The inspection shall ensure that hose caps are in place and not damaged. Hose threads shall be inspected for damage. Valve handles shall be present and not damaged. Gaskets shall be inspected for damage or deterioration. Hose valves shall be inspected for leaks and to ensure that no obstructions are present.



- Standpipe systems hose valves equipped with pressure restricting devices shall be inspected to ensure that restricting devices are present.

**Hose (as per NFPA 1962):**

- Hose shall be inspected and services tested as specified NFPA 1962, within in 90 days prior to being placed in service for the first time and at least **annually** thereafter. Hose carried on fire apparatus shall be loaded in such a way that air can circulate under the hose load to eliminate or reduce the growth of mildew in the hose jacket and rust and corrosion.
- Only clean, dry hose shall be placed into service.
- Hose shall be removed from the apparatus and reloaded so that the folds occur at different positions with sufficient frequency to prevent damage and the setting of permanent folds in the rubber lining.
- Large-diameter hose used to supply a pump from a hydrant shall be protected from chafing with chafing blocks or similar protection where it comes in contact with pavement or curbing.
- When connecting a pump to a hydrant, the hose shall be bent slightly to avoid kinks when the water is turned on.
- Care shall be taken to prevent the hose from chafing.
- Care shall be taken to avoid dragging large-diameter fire hose, but if the hose must be dragged, it shall be dragged when flat.
- Remove and inspect the hose , including gaskets, and re-rack or re-reel at intervals in accordance with NFPA 1962.
- Occupant, and attack hose (if equipped) shall be physically inspected **annually** to determine that it is free from debris, that it exhibits no evidence of rot, mildew, or damage by vermin. The inspection should also ensure that it doesn't have burns, cuts, abrasions, coupling or nozzle damage, gaskets missing or deterioration, or incompatible threads on coupling.
- Hose must be removed from service and replaced with new hose or nozzle.
- Hose shall be un-racked, unreeled, or unrolled **annually**. It should also be verified that hose is not connected to hose rack nipple or valve and that hose test is not outdated.

**Hose Nozzle (as per NFPA 1962):**

- All nozzles shall be inspected after each use and at least **annually**. The inspection shall include verification of waterway clear of obstructions, no damage to tip, full operation of adjustments such as pattern selection, proper operation of shutoff valve, no missing parts and the thread gasket in good condition. If the nozzle fails the inspection for any reason, it shall be removed from service and repaired or replaced.

**Hose Rack or Storage Device:**

- Storage device shall be inspected **annually** for damage, obstruction, difficulty in operation, hose improperly racked or rolled, nozzle clip placement and nozzle containment.
- If enclosed in cabinet hose rack shall be inspected that it will swing out at least 90 degrees.

**Cabinet:**

- Cabinet overall condition must be inspected **annually** for corroded or damaged parts, difficulty in opening cabinet doors, cracked door glazing.
- If cabinet is break-glass type; is lock functioning properly, is break-glass device missing or not attached.
- Cabinet not properly identified as containing fire equipment, visible obstructions and all valves, hoses, nozzles, fire extinguisher, etc. are easily accessible.

**Pressure Reducing and Relief Valves:**

**Fire Pumps:**

- All circulation relief valves shall be inspected **monthly**, test to verify that water flows through the valve when the fire pump is operating.

**NOTE:** As required by the Fire Department Commissioner.

- **Pressure relief valves** shall be inspected **weekly** to verify that the pressure downstream of the relief valve fittings in the fire pump discharge piping does not exceed the pressure for which the system components are rated.

**B. Fire Booster and Special Service Pumps:**

**Pump House, Heating Ventilating Louvers:**

- The visual inspection shall be performed **weekly** to ensure heat is not less than 40°F; and 70°F for pump room with diesel pumps without engine heaters.
- Ventilating louvers shall be free to operate.

**Fire Pump:**

- A **weekly** visual inspection shall be made to ensure the pump suction, discharge and by-pass valves are fully open.
- All piping shall be free of leaks.
- Suction line pressure gauge readings shall be normal and reservoir should be full;
- System line pressure gauge readings shall be normal.
- Wet pit suction screens shall be unobstructed and in place.
- The accuracy of pressure gauge and sensors, pump shaft endplay, coupling alignment and wet pit suction screen should be checked **annually**.

**Diesel Engine Fire Pump System:**

- **Fuel system** - Tank level shall be 2/3 full, the tank float switch shall be in auto position, solenoids valve operational, check for water in the fuel system and condition of flexible hoses connectors **weekly**.
- **Lubrication system** - Oil level in right angle gear drive is normal and ensure that lube oil heater is adequately lubricated **weekly**;
- **Cooling system** - Check level, adequate cooling water to heat exchanger, water pump, condition of flexible hoses and connections **weekly**; **annually** inspect duct work, clean louvers (combustion air).
- **Exhaust system** - check for any leakage, the drain condensate trap **weekly**;
- **Quarterly** check insulation and fire hazards.
- **Battery system** - Check electrolyte level of battery system along with the charger and charge rate **weekly**;
- **Monthly** - Remove corrosion on pump casing, clean and dry housing;
- **Quarterly** - Check that terminals clean and tight;

- **Electrical System** - A general inspection, such controller pilot light on, transfer switch is closed, reverse phase alarm pilot light is off or normal phase rotation pilot light is on oil level in vertical motor sight glass is normal **weekly**.
- Check **monthly** circuit breakers or fuses;
- Check **quarterly** for wire chafing where subject to movement.

### **C. Water Storage Tank:**

#### **Condition of water in tank:**

##### **Water Level:**

- Tanks without supervised water level alarms constantly attended location shall be inspected **monthly**.
- Tanks with supervised water level alarms constantly attended location shall be inspected **quarterly**.

##### **Air Pressure:**

- Air pressure without supervised air pressure source shall be inspected **monthly**.
- Air pressure with supervised air pressure source shall be inspected **quarterly**.

##### **Water Temperature:**

- The temperature of water tanks shall not be less than 40°F.
- The temperature of water in the tanks **without** low temperature alarms connected to a constantly attended location shall be inspected and recorded **daily** during the heating season.
- The temperature of water in the tanks with low temperature alarms connected to a constantly attended location shall be inspected and recorded **weekly** during the heating season.

##### **Heating System:**

- The heating system and components including piping without a low temperature alarm shall be inspected **daily**.
- The heating system and components including piping with a low temperature alarm shall be inspected **weekly**.

##### **Tank Exterior:**

- The **exterior** of the tank, **supporting structure**, vents, foundation, and catwalks or ladders shall be inspected **quarterly** for damages and weakening.
- The **area surrounding** the tank shall be inspected **quarterly** to ensure it is free of combustible storage, trash, debris, brush, or material that could present a fire exposure hazard.
- Any accumulation of material on or near parts that could result in accelerated corrosion or rot; ice buildup; the exterior side and top of embankments supporting coated fabric tanks are free of erosion.
- **Expansion Joints** shall be inspected **annually** for leaks and cracks.
- **Hoops and Grillage** of a wooden tank shall be inspected **annually**.
- **Exterior** painted, coated or insulated surfaces of the tank and supporting structure, where provided shall be inspected **annually** for signs of degradation.
- **Interior Inspection** of steel tanks without corrosion protection shall be inspected every **3 years**.
- The interior of all other types of tanks shall be inspected every **5 years**. The tank interior shall be inspected for signs of pitting, corrosion, spalling, other forms of

deterioration, waste materials and debris aquatic growth and local or general failure of interior coating.

#### **D. Valve and Valve Component:**

##### **Deluge Valves:**

- The valve **enclosure** without temperature alarm heating equipment is subject to freezing shall be inspected **daily** during cold weather for its ability to maintain a minimum temperature of at least 4°C (40°F).
- Valves **enclosures** equipped with **low temperature alarms** shall be inspected **weekly** during cold weather.
- **Exterior valves** shall be externally inspected **monthly** to ensure it is free from physical damage, the valve seat is not leaking, all trim valves are in the appropriate open or closed position and electrical components are in service.
- **Interior valves** and the condition of detection devices shall be inspected **annually** when the trip test is conducted.
- **Internal inspection** of valves that can be reset without removal of a faceplate shall be permitted to be conducted every **5 years**.
- **Strainers, filters, restricted orifices** and diaphragm chambers shall be inspected internally every **5 years** unless test indicates a greater frequency is necessary.

##### **Dry Pipe Valves/ Quick Opening Devices:**

- The valve **enclosure** heating equipment is subject to freezing shall be inspected **daily** during cold weather for its ability to maintain a minimum temperature of at least 4°F (40°F).
- Valves **enclosures** equipped with **low temperature alarms** shall be inspected **weekly** during cold weather.
- **Exterior** dry pipe valves shall be externally inspected **monthly** to ensure they are free from physical damage, the intermediate chamber is not leaking, all trim valves are in the appropriate open or closed position and electrical components are in service.
- **Interior** of the dry pipe valves shall be inspected **annually** when the trip test is conducted.
- **Strainers, filters, restricted orifices** and diaphragm chambers shall be inspected internally every **5 years** unless test indicates a greater frequency is necessary.

##### **Backflow Prevention Assemblies:**

- The double and single check assembly valves and double check detector assembly valve shall be inspected **weekly** to ensure that the OS&Y isolation valves are in the normal open position.
- Valves secured with locks or electrically supervised shall be inspected **monthly**.

##### **Fire Department Connections:**

- Fire Department connection shall be inspected **quarterly** to verify the connections are visible and accessible, couplings or swivels are not damaged and rotate smoothly.
  - Plugs or caps shall be in place and undamaged.
  - Gaskets shall be in place and in good working conditions.
  - Identification signs are in place (such as distance to the nearest fire hydrant).
  - The check valves are fully operational; not leaking.
  - The automatic drain valve shall be placed in the **horizontal** position and operating properly.

- The clappers within FDC shall be in place and operating properly.

**Control Valves:**

- All indicating valves controlling water supplies shall be sealed, locked or provided with other approved methods as outlined in NFPA 25, 2011 edition. A seal is defined as an easily removable device (no key required) that will indicate the unauthorized operation of a valve.
- Using this method shall require **weekly** inspections of each valve by the C of F holder. All indicating valves controlling water supplies equipped with locks and/or supervised shall be inspected **monthly**.
- The inspection shall verify that, it is the normal open or closed position, properly sealed, locked, or supervised, provided with appropriate wrenches, free from external leaks and provided with appropriate identification.

**Alarm Valves:**

- **Exterior** alarm valves shall be externally inspected **monthly** to ensure the gauges indicate normal supply water pressure is being maintained.
- The valve shall be free of physical damage and all valves are in the appropriate open or closed position. The retarding chamber or alarm drains shall be in a good condition without leaks.
- All **alarm valve** and their associated **strainers, filters, and restricted orifices** shall be inspected **internally** every **5 years** unless test indicates a greater frequency is necessary.

**Check Valves:**

- Shall be inspected **internally** every **5 years** to verify that all components operate correctly, move freely and are in good condition.

## **II. TEST**

### **A. Standpipe Systems:**

#### **Alarm Devices:**

- Vane-type and pressure type water flow alarm and supervisory devices shall be tested **semi-annually** to verify that they are functional.
- Mechanical water-flow devices including, but not limited to water motor gongs, shall be tested **quarterly**.

#### **Gauges:**

- Gauges shall be replaced every **5 yrs** or tested every 5 yrs by comparison with a calibrated gauge. Gauges that are not accurate within 3% of the full scale shall be recalibrated or replaced.

### **B. Fire Booster and Special Service Pumps:**

#### **Pump Operation:**

- A **monthly** test of fire pump assemblies shall be conducted without flowing water and shall be conducted by starting the pump automatically. An electric pump shall run a minimum of 10 minutes and diesel pump shall run a minimum of 30 minutes.
- An **annual** test of each pump assembly shall be conducted under minimum rated and peak flows of the fire pump by controlling the quantity of water discharged through approved test devices. The additional testing and inspection of the fire pump components shall be performed with the manufacturer's requirements or the alternative fire pump inspection, maintenance and procedures in NFPA 25, 2011 ed.

### **C. Water Storage Tank:**

#### **Temperature Alarms:**

- Low water temperature alarms shall be tested **monthly** cold weather only.

#### **High Temperature Limit Switches:**

- High water temperature limit switches on tank heating system shall be tested **monthly** whenever the heating system is in service.

#### **Water Level Alarms:**

- High and low water level alarms shall be tested **semi-annually**.

#### **Level Indicator:**

- Level indicator shall be tested every **5 years** for accuracy and freedom of movement.

#### **Pressure Gauges:**

- Pressure gauges shall be tested every **5 years** with a calibrated gauge according the manufacturer's manual. Gauges not accurate to within 3 percent of the scale of gauge being tested shall be recalibrated or replaced.

### **D. Valve and Valve Component:**

#### **Main Drains Test:**

- This test shall be conducted **annually** at each water-based fire protection system riser to determine whether there has been change in the condition of the water supply piping and control valves.
- Systems where the sole water supply is through a backflow preventer and/or pressure reducing valves, the main drain test of at least one system downstream of the device shall be conducted on a **quarterly** basis.

### **Dry Pipe Valves / Quick – Opening Devices:**

- The priming water level shall be tested **quarterly**. High priming water levels can affect the operation of supervisory air or nitrogen pressure maintenance device. Testing the water level is done by opening the priming level test valve, if water flows, drain it, close the valve when water stops flowing and air discharges, if air discharges when the valve is opened, the priming water level could be too low. To add priming water, refer to manufacturer's instructions.
- **Low air pressure alarms** shall be tested **quarterly** in accordance with the manufacturer's instructions.
- **Quick-opening devices** shall be tested **quarterly** following the below procedures:
  - Close the system control valve, open the main drain valve and keep it in the open position, verify that the quick-opening device control valve is open. Open the inspector's test valve. A burst of air from device indicates that it has tripped the device's control valve. Return the device to service in accordance with manufacturer's instructions and return the system to service.
  - Each dry pipe valve shall be trip tested **annually** during warm weather. Should be tested in the spring to allow time before the onset of cold weather for all water that has entered the system or condensation to drain to low points or back to the valve.
  - **Every 3 yrs** and whenever the system is altered, the dry pipe valve shall be trip tested with the control valve fully open and the quick – opening device in service.
  - A full flow trip test - requires at least two individuals, one of whom is situated at the **dry pipe valve** while the other is at the inspector's test. If possible they should in communication with each other. A full flow trip test is conducted as follows:
    - 1- The main drain valve is fully opened to clean any accumulated scale or foreign material from the supply water piping. The main drain valve then closed.
    - 2- The system air or nitrogen pressure and the supply water pressure are recorded.
    - 3- The system air or nitrogen pressure is relieved by opening the inspector's test valve completely. Concurrent with opening the valve, both testers start their stopwatches. If two-way communication is not available, the tester at the dry valve is to react to the start of downward movement on the air pressure gauge.
    - 4- Testers at the dry pipe valve note the air pressure at which the valve trips and note the tripping time.
    - 5- Testers at the inspector's test note the time at which water flows steadily from the test connection. This time is noted for comparison purposes to previous tests and is not meant to be a specific pass/fail criterion. Note that NFPA 13, does not require water delivery in 60 seconds for all systems.
    - 6- When clean water flows, the test is terminated by closing the system control valve.
    - 7- The air or nitrogen pressure and the time elapsed are to be recorded as follows:
      - a- from the complete opening of the test valve to the tripping of the valve,

**b-** from the complete opening of inspector's valve to the start of steady flow from the test connection.

- 8-** All low point drain are opened and then closed when water ceases to flow. The dry pipe valve and quick-opening are reset, if installed, in accordance with the manufacturer's instruction, and the system is returned to service.

**Dry/Preaction System Air Leakage Test:**

- Preaction systems shall be tested once every 3 years for air leakage, using one of the following test methods:

**(1)** A pressure test at 40 psi (3.2 bar) for 2 hours. The system shall be permitted to lose up to 3 psi (0.2 bar) during the duration of the test. Air leaks shall be addressed if the system loses more than 3 psi (0.2 bar) during this test.

**(2)** With the system at normal system pressure, shut off the air source (compressor or shop air) for 4 hours. If the low air pressure alarm goes off within this period, the air leaks shall be addressed.

**Pressure reducing and relief valves:**

**Standpipe Systems Master Pressure Reducing Valves:**

- **Annually** a full flow test shall be conducted on master pressure reducing valve stations and shall be compared to previous test result and the results from the original installation or acceptance test.
- **Quarterly**, a partial flow test shall be conducted with a flow rate great enough to lift the valve seat.

**Circulation Relief Valves:**

- During the **annual** fire pump test, the closure of circulation relief valve shall be verified to be in accordance with the manufacturer's specifications.

**Pressure Relief Valves:**

- During the **annual** fire pump flow test, the pressure of relief valve shall be verified to be correctly adjusted and set to relieve at the correct pressure and to close below that pressure setting.

**Backflow prevention assemblies:**

- Backflow prevention assemblies installed in fire protection system piping shall be tested **annually** in accordance with the following:
  - 1- A forward flow test shall be conducted at the system, including where hydrants or inside hose stations are located downstream of the backflow preventer.
  - 2- A backflow performance test, as required by the authority having jurisdiction shall be conducted at the completion of the forward flow test.

**Control Valves:**

- Each control valve shall be operated **annually** through its full range and returned to its normal position. This test shall be conducted every time the valve is closed. Post indicator and outside screw and yoke valves shall be backed a one-quarter turn from the fully open position to prevent jamming.
- Valve **supervisory switches** shall be tested **semiannually**. A distinctive signal shall indicate movement from the valve's normal position during either the first two revolutions of a hand wheel or when the stem of the valve has moved no more than 1/5<sup>th</sup> of the distance from its normal position.

**Gauges:**



- Gauges shall be replaced **every 5 yrs** or tested **every 5 yrs** by comparison with a calibrated gauge. Gauges that are not within 3% accurate of the full scale shall be recalibrated or replaced.

**High Temperature Limit Switches:**

- High water temperature limit switches on tank heating system shall be tested **monthly** whenever the heating system is in service.
- Hose (as per NFPA 1962), service testing of hose is undertaken to confirm its suitability for continued use. Because there is a potential for catastrophic failure during this testing, it is important that adequate safety precautions be taken. The service test pressure for hose manufactured prior to July 1987 to meet the requirements of the 1979 and previous editions of NFPA 1962 will be 11/2 – 21/2 single jacket hose with service test pressure 150 psi. Hose manufactured in July 1987 and after to meet the requirements of the 1987 and subsequent editions of NFPA 1962, Standard on fire Hose, is stenciled on each length of hose and read “Service Test to ...PSI per NFPA 1962”.
- In-service hose shall be removed and service tested at intervals **not exceeding 5 years** after installation and **every 3 years** thereafter.

**Pressure reducing and relief valves:**

**Standpipe Systems:**

- At 3 year intervals, a full flow test shall be conducted on pressure reducing valves and shall be compared to previous test result and the results from the original installation or acceptance test. Annually, a partial flow test shall be conducted with a flow rate great enough to lift the valve seat.

**Circulation Relief:**

- During the **annual** fire pump test, the closure of circulation relief valve shall be verified to be in accordance with the manufacturer’s specifications.

**Pressure Relief Valves:**

- During the **annual** fire pump flow test, the pressure of relief valve shall be verified to be correctly adjusted and set to relieve at the correct pressure and to close below that pressure setting.

**Standpipe systems equipped with hose racks:**

- A full flow test shall be conducted on each valve at **5 years** intervals and shall be compared to previous test results.

**Hydrostatic test (5 years) See NYC Fire Code section 905.12.1**

- Upon order of the commissioner, but at least once every 5 years, the standpipe system shall be subjected to a hydrostatic pressure test and a flow test to demonstrate its suitability for department use. These tests shall be conducted in compliance with the requirements of the rules and shall be conducted at the owner's risk, by his or her representative before a representative of the Fire Department.

**Rooftop Standpipe System Flow Test**

- At least every 5 years a flow test shall be conducted at the hydraulically most remote hose connections of each zone of an automatic standpipe system to verify that the water supply still provides the designed pressure of the required flow. All systems shall be flow tested and pressure tested at the requirements at the designed criteria in effect at the time of installation, or as required by the FDNY.

### **III. MAINTENANCE**

#### **A. Standpipe Systems:**

##### **Valves (ALL TYPES)**

###### **Control Valves:**

- The operating stems of outside screw and yoke valves shall be lubricated **annually**. The valve then shall be completely closed and reopened to test its operation and distribute the lubricant.

###### **Low point drains (dry pipe system):**

- Shall be drained after each operation and before the onset of freezing weather conditions and thereafter as needed.

###### **Hose Connections**

The following devices must be maintained, repaired and/or replaced **annually**:

- missing cap, valve handles, restricting device and cap gaskets must be replaced.
- damaged fire hose connection, deteriorated cap gaskets and leaking valves must be repaired.
- manual, semiautomatic, or dry standpipe that does not operate smoothly must be repaired or lubricated.

#### **B. Fire Booster and Special Service Pumps:**

- A preventive maintenance program shall be maintained on all components of the pump assembly in accordance with manufacturer's recommendations. If there is no manufacturer's recommendations for preventive maintenance use Table 8.5.3 of NFPA 25, 2011.

#### **C. Water Storage Tank:**

##### **Water Level:**

- Tank shall be maintained full or at the designed water level.

##### **Drain Silt**

- Silt shall be removed during interior inspection (**semiannually**) or more frequently as needed to avoid accumulation to the level of the tank outlet.

##### **Embankment-Supported Coated Fabric (ESCF) Suction Tanks:**

- The maintenance of ESCF tanks shall be done according the tank manufacturer manual.

#### **D. Valve and Valve Component:**

##### **Control Valves:**

- The operating stems of outside screw and yoke valves shall be lubricated **annually**. The valve then shall be completely closed and reopened to test its operation and distribute the lubricant.

##### **Pre-action/ Valves**

- During the annual trip test, the interior of the pre-action or deluge valve shall be cleaned thoroughly and the parts replaced or repaired as necessary.

##### **Dry Pipe Valves / Quick – Opening Devices**

- During the **annual trip test**, the interior of the pre-action or deluge valve shall be cleaned thoroughly and the parts replaced or repaired as necessary.

## 10.2 Inspection Reference Guide

### Reference Guide Defining Individuals Qualified as to Whom Can Perform Inspection, Testing and Maintenance for Standpipe and Hose Systems.

These check lists will be given to you by the FDNY examiners when taking this test at the Fire Department.

<b>C of F</b>	<b>Certificate of Fitness S-13 City Wide Standpipe System.</b>			
<b>Engineer</b>	<b>Refrigeration Operating Engineer (Q-01 &amp; Q-99), NYC High Pressure Operating Engineer, NYS High Pressure Operating Engineer with S-13 C of F. *(For employees of a single or multiple properties under common ownership employed by the same building owner/management company)</b>			
<b>MFSPC</b>	<b>Master Fire Suppression Piping Contractor License (A or B) with S-13 C of F.</b>			
<b>MP</b>	<b>Master Plumber License (MP) with S-13 C of F.</b>			
<sup>1</sup> Must have an S-12 or S-15 Certificate of Fitness. <sup>2</sup> S-95 Supervision for Fire alarm Systems & other related systems. <sup>3</sup> Follow testing requirement. <sup>4</sup> Record must be maintained to be checked annually. <sup>5</sup> Must be performed once annually by licensed contractor. <sup>6</sup> Independent standpipe system.				
<b>Components</b>		<b>May be performed by</b>		
		<b>C of F</b>	<b>Engineer</b>	<b>MFSPC</b>
<b>I. INSPECTION</b>				
<b>Frequency</b>				
<b>A. Standpipe Systems</b>				
<b>WEEKLY</b>				
Gauge (dry) non supervised (6.2.2.2)	<b>Yes</b>	<b>Yes</b>	<b>Yes</b>	<b>Yes</b>
<b>MONTHLY</b>				
Gauge (dry) supervised	<b>Yes</b>	<b>Yes</b>	<b>Yes</b>	<b>Yes</b>
Gauge – wet pipe system (6.2.2.1)	<b>Yes</b>	<b>Yes</b>	<b>Yes</b>	<b>Yes</b>
<b>QUARTERLY</b>				
Alarm devices (13.2.6)	<b>Yes</b>	<b>Yes</b>	<b>Yes</b>	<b>Yes</b>
Pressure restricting device (6.1.1.2)	Hose connections (13.5.2.1)	<b>Yes</b>	<b>Yes</b>	<b>Yes</b>
<b>ANNUALLY</b>				
Buildings – (prior to freezing weather) exterior of building should be examined to prevent freeze-ups fire suppression piping. (4.1.1.1)	<b>Yes</b>	<b>Yes</b>	<b>Yes</b>	<b>Yes</b>
Cabinet (NFPA 1962) (6.1.1.2)	<b>Yes</b>	<b>Yes</b>	<b>Yes</b>	<b>Yes</b>
Hanger/seismic bracing (floor level) (5.2.3)	<b>Yes</b>	<b>Yes</b>	<b>Yes</b>	<b>Yes</b>
Hose storage device (Hose racks) (NFPA 1962) (6.1.1.2)	<b>Yes</b>	<b>Yes</b>	<b>Yes</b>	<b>Yes</b>
Hose (NFPA 1962)(6.1.1.2)	<b>Yes</b>	<b>Yes</b>	<b>Yes</b>	<b>Yes</b>
Pressure restricting device (6.1.1.2)	Hose racks (13.5.3.1)	<b>Yes</b>	<b>Yes</b>	<b>Yes</b>
Piping 6.2.1	Piping (6.2.1)	<b>Yes</b>	<b>Yes</b>	<b>Yes</b>
	Hanger/seismic bracing (floor level) (5.2.3)			
	Supervisory device (5.2.5)			

Components			May be performed by			
			C of F	Engineer	MFSPC	MP
<b>I. INSPECTION</b>						
<b>B. Fire, Booster and Special Service Pumps</b>						
<b>WEEKLY</b>						
Pump house, heating ventilating louvers (8.2.2(1))			<b>Yes</b>	<b>Yes</b>	<b>Yes</b>	<b>Yes</b>
Fire pump system (8.2.2)			<b>Yes</b>	<b>Yes</b>	<b>Yes</b>	<b>Yes</b>
Diesel Engine System	Fuel	Tank level (8.1.2)	<b>Yes</b>	<b>Yes</b>	<b>Yes</b>	<b>Yes</b>
		Tank float switch (8.1.2)				
		Solenoids valve operation (8.1.2)				
		Water in the fuel system (8.1.2)				
		Flexible hoses and connectors (8.1.2)				
		Piping (8.2.2)				
		Tank vents and overflow piping unobstructed (8.2.2)				
	Lubrication system	Oil level (8.1.2)				
		Lube oil heater (8.1.2)				
		Crankcase breather (8.1.2)				
	Cooling system	Level (8.1.2)				
		Adequate cooling water to heat exchanger (8.1.2)				
		Water pumps (8.1.2)				
		Conditions of flexible hoses & connection (8.1.2)				
		Jacket water heater (8.1.2)				
	Exhaust system	Leakage (8.1.2)				
		Drain condensate trap (8.1.2)				
		Hangers & supports (8.1.2)				
		Flexible exhaust section (8.1.2)				
	Electrical system	General inspection (8.1.2)				
Operation of safeties & alarms (8.1.2)						
Circuit breakers or fuses (8.1.2)						
<b>MONTHLY</b>						
Diesel Engine System		Circuit breakers or fuses (8.1.2)	<b>Yes</b>	<b>Yes</b>	<b>Yes</b>	<b>Yes</b>
		Charger & charge rate (8.1.2)	<b>Yes</b>	<b>Yes</b>	<b>Yes</b>	<b>Yes</b>
<b>QUARTERLY</b>						
Diesel Engine System	Exhaust system	Insulation & fire hazards (8.1.2)	<b>Yes</b>	<b>Yes</b>	<b>Yes</b>	<b>Yes</b>
	Electrical system	Wire chafing where subject to movement (8.1.2)				
<b>SEMIANNUALLY</b>						
Diesel Engine System	Electrical system	Operation of safeties and alarms (8.1.2)	<b>Yes</b>	<b>Yes</b>	<b>Yes</b>	<b>Yes</b>

Components		May be performed by				
		C of F	Engineer	MFSPC	MP	
<b>I. INSPECTION</b>						
<b>B. Fire, Booster and Special Service Pumps</b>						
<b>ANNUALLY</b>						
Fire pump system	Check accuracy of pressure gauges and sensors (8.1.2)		Yes	Yes	Yes	Yes
	Check pump shaft endplay, coupling alignment (8.1.2)					
	Wet pit suction screens (after each pump operation) (8.1.2)					
Diesel Engine System	Cooling system	Inspect duct work, clean louvers (combustion air) (8.1.2)	Yes	Yes	Yes	Yes
Electrical system 2	Inspect emergency manual starting means (without power) (8.1.2)		Yes	Yes	Yes	Yes
	Tighten electrical connections as necessary (8.1.2)					
	Lubricate mechanical moving parts (excluding starters & relays) (8.1.2)					
	Calibrate pressure switch settings (8.1.2)					
<b>C. Water Storage Tank</b>						
<b>DAILY</b>						
Water temperature – without low temperature alarms (cold weather) (9.2.4.3)			Yes	Yes	Yes	Yes
Heating System – without low temperature alarms (cold weather) (9.2.3.2)			Yes	Yes	Yes	Yes
<b>WEEKLY</b>						
Temperature alarms not connected to constantly connected location (9.2.3.1)			Yes	Yes	Yes	Yes
Water temperature - with low temperature alarms NOT connected to a constantly attended location (cold weather) (9.2.4.3)			Yes	Yes	Yes	Yes
Heating system and components – with low temperature alarms (cold weather) (9.2.3.1)			Yes	Yes	Yes	Yes
<b>MONTHLY</b>						
Condition of water in tank – without water level alarms (cold weather) (9.2.4.3)			Yes	Yes	Yes	Yes
Temperature alarms connected to constantly attended location (9.2.4.2)			Yes	Yes	Yes	Yes
Water temperature - with low temperature alarms connected to a constantly attended location (heating season) (9.2.4.3)			Yes	Yes	Yes	Yes
Water level (without water level alarms) (9.1.1.2)			Yes	Yes	Yes	Yes
Air pressure - (without supervised air pressure source) (9.1.1.2)			Yes	Yes	Yes	Yes
<b>QUARTERLY</b>						
Condition of water in tank - with water level temperature alarms (cold weather below 40°F)			Yes	Yes	Yes	Yes
Water level (with supervised water level alarms) (9.2.1.1)			Yes	Yes	Yes	Yes
Air pressure – (with supervised air pressure source) (9.2.2.1)			Yes	Yes	Yes	Yes
Tank – exterior	Support structure (9.2.5.1)		Yes	Yes	Yes	Yes
	Catwalks and ladders (9.2.5.1)					
	Surrounding area (9.2.5.2)					
<b>ANNUALLY</b>						
Embankment-supported coated fabric (ESCF) suction tanks (9.4.6)			Yes	Yes	Yes	Yes
Exterior (paint, coat or insulated surfaces) (9.2.5.5)			Yes	Yes	Yes	Yes
Hoops and grillage of wooden tanks (AKA Dunnage) (9.2.5.4)			Yes	Yes	Yes	Yes

<b>Components</b>			<b>May be performed by</b>			
			<b>C of F</b>	<b>Engineer</b>	<b>MFSPC</b>	<b>MP</b>
<b>I. INSPECTION</b>						
<b>C. Water Storage Tank</b>						
<b>ANNUALLY</b>						
Expansion Joints (9.2.5.3)			<b>Yes</b>	<b>Yes</b>	<b>Yes</b>	<b>Yes</b>
<b>3 YEARS</b>						
Interior – (steel tanks without corrosion protection) (9.2.6.1.1)			<b>Yes</b>	<b>Yes</b>	<b>Yes</b>	<b>Yes</b>
<b>5 YEARS</b>						
Interior - all other types of tanks (9.2.6.1.2)			<b>Yes</b>	<b>Yes</b>	<b>Yes</b>	<b>Yes</b>
<b>D. Valve and Valve component</b>						
<b>DAILY</b>						
Dry valve - valve enclosure without temperature alarm (during cold weather) (13.4.3.1.1)			<b>Yes</b>	<b>Yes</b>	<b>Yes</b>	<b>Yes</b>
Dry pipe valves and quick opening devices – valve enclosure without temperature alarm (during cold weather)			<b>Yes</b>	<b>Yes</b>	<b>Yes</b>	<b>Yes</b>
<b>WEEKLY</b>						
Control Valves	Sealed (13.3.2.1)		<b>Yes</b>	<b>Yes</b>	<b>Yes</b>	<b>Yes</b>
Dry valves - valve enclosure equipped with low temperature alarms (during cold weather) (13.4.3.1.1.1)			<b>Yes</b>	<b>Yes</b>	<b>Yes</b>	<b>Yes</b>
Dry pipe valves and quick opening devices – valve enclosure equipped with low temperature alarms ( during cold weather) (13.4.4.1.1.1)			<b>Yes</b>	<b>Yes</b>	<b>Yes</b>	<b>Yes</b>
Pressure reducing & Relief valves	Diesel Fire Pumps	Casing relief valves (13.5.7.1)	<b>Yes</b>	<b>Yes</b>	<b>Yes</b>	<b>Yes</b>
		Pressure relief valves (13.5.7.2)				
Backflow Prevention assemblies (not secured with locks or electrically supervised)		Reduced pressure (13.6.1)	<b>Yes</b>	<b>Yes</b>	<b>Yes</b>	<b>Yes</b>
		Reduced pressure detectors (13.6.1)				
<b>MONTHLY</b>						
Control Valves	Locked (13.3.2.1.1)		<b>Yes</b>	<b>Yes</b>	<b>Yes</b>	<b>Yes</b>
	Tamper switches (13.3.2.1.1)					
Alarm valves	Exterior (13.4.1.1)		<b>Yes</b>	<b>Yes</b>	<b>Yes</b>	<b>Yes</b>
Deluge valves – Exterior (13.4.3.1.6)			<b>Yes</b>	<b>Yes</b>	<b>Yes</b>	<b>Yes</b>
Dry pipe valves and quick opening devices - <b>Exterior</b> (13.4.4.1.4)			<b>Yes</b>	<b>Yes</b>	<b>Yes</b>	<b>Yes</b>
Pressure regulating & Relief valves	Electric Fire Pumps	Casing relief valves (8.2)	<b>Yes</b>	<b>Yes</b>	<b>Yes</b>	<b>Yes</b>
		Pressure relief valves (8.2)				
Backflow Prevention assemblies (secured with locks or electrically supervised) (13.6.1)		reduced pressure (13.6.1)	<b>Yes</b>	<b>Yes</b>	<b>Yes</b>	<b>Yes</b>
		reduced pressure detectors (13.6.1)				
<b>QUARTERLY</b>						
Pressure regulating & Relief valves	Hose connections (13.5)		<b>Yes</b>	<b>Yes</b>	<b>Yes</b>	<b>Yes</b>
	Floor markings (13.5.6.1.8)					
	Calibration (13.5.6.1.8)					
	Setting notches (13.5.6.1.8)					
Fire Department Connections (13.7.1)	Caps combination with standpipe/sprinkler ( should be painted yellow		<b>Yes</b>	<b>Yes</b>	<b>Yes</b>	<b>Yes</b>
	Swivel turn freely					
	Ball drip					
	Signage					
Hose Valve (13.5.6.1)			<b>Yes</b>	<b>Yes</b>	<b>Yes</b>	<b>Yes</b>

Components	May be performed by				
	C of F	Engineer	MFSPC	MP	
<b>I. INSPECTION</b>					
<b>D. Valve and Valve component</b>					
<b>ANNUALLY</b>					
Dry pipe and deluge valves – interior (when trip test is conducted) (13.4.4.1.5)	No	Yes	Yes	Yes	
Dry pipe valves and quick opening devices - interior (when trip test is conducted) (13.4.4.1.5)	No	Yes	Yes	Yes	
Pressure regulating & relief valves – Hose racks (13.5.3.1)	No	Yes	Yes	Yes	
Standpipe system piping and hangers (6.2.1)	No	Yes	Yes	Yes	
<b>5 YEARS</b>					
Alarm valves	Interior (13.4.1.2)	No	No	Yes	Yes
	Strainers, filters, orifices (13.4.1.2)				
Check Valves - Interior (13.4.2.1)	No	No	Yes	Yes	
Deluge valves	Strainers, filters, orifices (13.4.3.1.8)	No	No	Yes	Yes
Dry pipe valves and quick opening devices	Strainers, filters, orifices (13.4.4.1.6)	No	No	Yes	Yes

### 10.3 Testing Reference Guide

## Reference Guide Defining Individuals Qualified as to Whom Can Perform Inspection, Testing and Maintenance for Standpipe and Hose Systems.

**These Reference Guide will be given to you by the FDNY examiners when taking this test at the Fire Department.**

<b>C of F</b>	<b>Certificate of Fitness S-13 City Wide Standpipe System.</b>					
<b>Engineer</b>	<b>Refrigeration Operating Engineer (Q-01 &amp; Q-99), NYC High Pressure Operating Engineer, NYS High Pressure Operating Engineer with S-13 C of F (For employees of a single or multiple properties under common Ownership employed by the same building owner/management company)</b>					
<b>MFSPC</b>	<b>Master Fire Suppression Piping Contractor License (A or B) with S-13 C of F.</b>					
<b>MP</b>	<b>Master Plumber License (MP) with S-13 C of F.</b>					
<sup>1</sup> Must have an S-12 or S-15 Certificate. <sup>2</sup> S-95 Supervision for Fire alarm Systems & other related systems. <sup>3</sup> Follow testing requirement. <sup>4</sup> Record must be maintained to be checked annually. <sup>5</sup> Must be performed once annually by licensed contractor.						
<b>Components</b>			<b>May be performed by</b>			
			<b>C of F</b>	<b>Engineer</b>	<b>MFSPC</b>	<b>MP</b>
<b>II. TEST</b>						
<b>Frequency</b>						
<b>A. Standpipe Systems</b>						
<b>QUARTERLY (4)</b>						
Alarm Devices	Water flow alarms (13.2.6)	<b>Yes</b>	<b>Yes</b>	<b>Yes</b>	<b>Yes</b>	
	Supervisory devices (13.4.3.2.13)	<b>Yes</b>	<b>Yes</b>	<b>Yes</b>	<b>Yes</b>	
<b>SEMIANNUALLY (2)</b>						
Alarm Devices (Vane-Type and Pressure Type water flow devices) (13.2.6)		<b>Yes</b>	<b>Yes</b>	<b>Yes</b>	<b>Yes</b>	
<b>5 YEARS</b>						
Gauges - Remove and send for calibration test or replace as required (13.2.7.2)		<b>No</b>	<b>Yes<sup>4</sup></b>	<b>Yes</b>	<b>Yes</b>	
<b>B. Fire, Booster and Special Service Pumps</b>						
<b>WEEKLY (52)</b>						
Diesel Pump operation - No-flow condition (8.3.1)		<b>No</b>	<b>Yes</b>	<b>Yes</b>	<b>Yes</b>	
Diesel Engine system	Solenoids valve operation (8.1.2)	<b>No</b>	<b>Yes</b>	<b>Yes</b>	<b>Yes</b>	
	Fuel Tank float switch (8.1.2)					
	Solenoids valve operation (8.1.2)					
<b>MONTHLY (1)</b>						
Electric Fire pump - (minimum of 10 minutes) (8.3.1.2)		<b>No</b>	<b>Yes</b>	<b>Yes</b>	<b>Yes</b>	
Electrical system <sup>2</sup>	Isolating switch & circuit breaker (8.1.2)	<b>No</b>	<b>Yes</b>	<b>Yes</b>	<b>Yes</b>	
Battery system	Specific gravity or state of charge (8.1.2)					



Components			May be performed by			
			C of F	Engineer	MFSPC	MP
<b>II. TEST</b>						
<b>Frequency</b>						
<b>B. Fire, Booster and Special Service Pumps</b>						
<b>SEMIANNUALLY (2)</b>						
Electrical system <sup>2</sup>	Operate manual starting means (electrical) (8.1.2)		No	Yes <sup>4</sup>	Yes	Yes
Diesel Engine System	Cooling system	Antifreeze protection level (8.1.2)	No	Yes	Yes	Yes
	Electrical system	Operation of safeties and alarms (8.1.2)				
<b>ANNUALLY (1)</b>						
Pump operation - Full flow condition (8.3.3)			No	No	Yes	Yes
Electrical system <sup>2</sup>	Trip circuit breaker (if mechanism provided) (8.1.2)		No	No	Yes	Yes
	Operate emergency manual starting means (without power) (8.1.2)					
Exhaust system	Excessive back pressure (8.1.2)		No	No	Yes	Yes
Diesel Engine System	Tank vents and overflow piping unobstructed (8.1.2)		No	No	Yes	Yes
<b>C. Water Storage Tank</b>						
<b>MONTHLY (12)</b>						
Temperature alarms (cold weather) (9.3.3)			No	Yes <sup>5</sup>	Yes	Yes
High temperature limit switches (whenever the heating system is in service) (9.3.4)			No	Yes <sup>5</sup>	Yes	Yes
<b>SEMIANNUALLY (2)</b>						
Water level alarms (9.3.5)			No	Yes <sup>5</sup>	Yes	Yes
<b>5 YEARS</b>						
Level indicators (9.3.1)			No	Yes <sup>5</sup>	Yes	Yes
Pressure gauges (9.3.6.1)			No	Yes <sup>5</sup>	Yes	Yes
<b>D. Valve and Valve Component</b>						
<b>QUARTERLY (4)</b>						
Main drain (where the sole water supply is through a backflow preventer and/or pressure reducing valves) (13.3.3.4)			No	Yes	Yes	Yes <sup>1</sup>
Dry pipe valves and quick opening devices	Priming water (13.4.3.2.1)		No	Yes <sup>5</sup>	Yes	Yes
	Low air pressure alarm (13.4.4.2.6)					
	Quick-opening devices (13.4.4.2.4)					
<b>SEMIANNUALLY (2)</b>						
Control Valves Tamper Switch	Supervisory Alarm (13.3.3.5)		No	Yes <sup>5</sup>	Yes	Yes
<b>ANNUALLY (1)</b>						
Hose Nozzle (NFPA 1962) (6.1.1.2)			No	No	Yes	Yes
Hose Storage device, racks (NFPA 1962) (6.1.1.2)			No	No	Yes	Yes
Standpipe – hose valve (Class I and Class III) (13.5.6.2.1)			No	Yes	Yes	Yes
Main drain (13.2.5)			No	No	Yes	Yes <sup>1</sup>

<b>Components</b>		<b>May be performed by</b>			
		<b>C of F</b>	<b>Engineer</b>	<b>MFSPC</b>	<b>MP</b>
<b>II. TEST</b>					
<b>Frequency</b>					
<b>D. Valve and Valve Component</b>					
<b>ANNUALLY (1)</b>					
Dry pipe valves and Quick opening devices	Trip test (13.4.4.2.2)	<b>No</b>	<b>No</b>	<b>Yes</b>	<b>Yes</b>
Control Valves	Position (13.3.3.1)	<b>No</b>	<b>No</b>	<b>Yes</b>	<b>Yes</b>
	Operation (13.3.3.1)				
Pressure reducing and Relief valves	Circulation relief (13.5.7.1.2)	<b>No</b>	<b>No</b>	<b>Yes</b>	<b>Yes</b>
	Pressure relief valves (13.5.7.2.2)				
Backflow prevention Assemblies (13.6.2)		<b>No</b>	<b>No</b>	<b>Yes</b>	<b>Yes</b>
<b>3 YEARS</b>					
Hose 1962 (NFPA 1962)		<b>No</b>	<b>Yes</b>	<b>Yes</b>	<b>Yes</b>
Dry pipe valves and quick opening devices	Full flow trip test (13.4.3.2.2)	<b>No</b>	<b>No</b>	<b>Yes</b>	<b>Yes</b>
Pressure reducing valve flow test		<b>No</b>	<b>No</b>	<b>Yes</b>	<b>Yes</b>
<b>5 YEARS</b>					
Hose (NFPA 1962)		<b>No</b>	<b>Yes</b>	<b>Yes</b>	<b>Yes</b>
Hydrostatic Test (6.3.2)		<b>No</b>	<b>No</b>	<b>Yes</b>	<b>Yes</b>
Standpipe system full flow test (6.3.1)		<b>No</b>	<b>No</b>	<b>Yes</b>	<b>Yes</b>
Gauges - Remove and send for calibration test or replace as required (13.2.7.2)		<b>No</b>	<b>Yes<sup>4</sup></b>	<b>Yes</b>	<b>Yes</b>

## 10.4 Maintenance Reference Guide

### Reference Guide Defining Individuals Qualified as to Whom Can Perform Inspection, Testing and Maintenance for Standpipe and Hose Systems.

**These Reference Guide will be given to you by the FDNY examiners when taking this test at the Fire Department.**

<b>C of F</b>	<b>Certificate of Fitness S-13 City Wide Standpipe System</b>					
<b>Engineer</b>	<b>Refrigeration Operating Engineer (Q-01 &amp; Q-99), NYC High Pressure Operating Engineer, NYS High Pressure Operating Engineer with S-13 C of F. (For employees of a single or multiple properties under common Ownership employed by the same building owner/management company).</b>					
<b>MFSPC</b>	<b>Master Fire Suppression Piping Contractor License (A or B) with S-13 C of F.</b>					
<b>MP</b>	<b>Master Plumber License (MP) with S-13 C of F.</b>					
<sup>1</sup> Must have an S-12 or S-15 Certificate of Fitness. <sup>2</sup> S-95 Supervision for Fire alarm Systems & other related systems. <sup>3</sup> Follow testing requirement. <sup>4</sup> Record must be maintained to be checked annually. <sup>5</sup> Must be performed once annually by licensed contractor.						
<b><u>Components</u></b>			<b><u>May be performed by</u></b>			
			<b>C of F</b>	<b>Engineer</b>	<b>MFSPC</b>	<b>MP</b>
<b>III. MAINTENANCE</b>						
<b>A. Standpipe Systems</b>						
<b>ANNUALLY (1)</b>						
Valves (all types)	Control valves (13.3.4)		<b>No</b>	<b>No</b>	<b>Yes</b>	<b>Yes</b>
	Dry pipe valves /quick opening devices (13.3.4)		<b>No</b>	<b>No</b>	<b>Yes</b>	<b>Yes</b>
Low point drains - (Dry pipe systems) <b>(AS NEEDED and before freezing conditions)</b> (13.4.4.3.2)			<b>No</b>	<b>No</b>	<b>Yes</b>	<b>Yes</b>
Hose Connections (6.1.2)	Lubricate		<b>No</b>	<b>Yes</b>	<b>Yes</b>	<b>Yes</b>
	Repair		<b>No</b>	<b>Yes</b>	<b>Yes</b>	<b>Yes</b>
	Replace		<b>No</b>	<b>Yes</b>	<b>Yes</b>	<b>Yes</b>
<b>5 YEARS</b>						
Obstruction Investigation (14.2.1)			<b>No</b>	<b>No</b>	<b>Yes</b>	<b>Yes</b>
<b>B. Fire, Booster and Special Service Pumps</b>						
<b>WEEKLY (52)</b>						
Diesel engine system	Fuel	Clean water in the system (8.1.2)	<b>No</b>	<b>Yes<sup>5</sup></b>	<b>Yes</b>	<b>Yes</b>
<b>MONTHLY (12)</b>						
Diesel engine system	Battery system	Remove corrosion, case exterior clean and dry (8.1.2)	<b>No</b>	<b>Yes<sup>5</sup></b>	<b>Yes</b>	<b>Yes</b>
<b>QUARTERLY (4)</b>						
Diesel engine system	Fuel	Clean Strainer, filter or dirt leg or combination (8.1.2)	<b>No</b>	<b>Yes<sup>5</sup></b>	<b>Yes</b>	<b>Yes</b>
	Lubricating system	Crankcase breather (8.1.2)				
	Cooling system	Water strainer (8.1.2)				

<b><u>Components</u></b>			<b><u>May be performed by</u></b>			
			<b>C of F</b>	<b>Engineer</b>	<b>MFSPC</b>	<b>MP</b>
<b>III. MAINTENANCE</b>						
<b>B. Fire, Booster and Special Service Pumps</b>						
<b>SEMI-ANNUALLY (2)</b>						
Diesel engine system	Electrical system	Boxes, panels and cabinets (8.1.2)	<b>No</b>	<b>Yes<sup>5</sup></b>	<b>Yes</b>	<b>Yes</b>
		Circuit breakers or fuses (8.1.2)				
<b>ANNUALLY (1)</b>						
Hydraulic (8.1.1.2)			<b>No</b>	<b>No</b>	<b>Yes</b>	<b>Yes</b>
Pump system	Lubricate pump bearings (8.1.2)		<b>No</b>	<b>No</b>	<b>Yes</b>	<b>Yes</b>
	Check accuracy of pressure gauges & sensors (8.1.2)					
	Wet pit suction screens (after each pump operation) (8.1.2)					
Mechanical transmission	Lubricate coupling (8.1.2)		<b>No</b>	<b>No</b>	<b>Yes</b>	<b>Yes</b>
	Lubricate right angle gear drive (8.1.2)					
Electrical system	Grease motor bearings (8.1.2)		<b>No</b>	<b>No</b>	<b>Yes</b>	<b>Yes</b>
Controller, various components (8.5 – varies)			<b>No</b>	<b>No</b>	<b>Yes</b>	<b>Yes</b>
Motor (8.1.1.2)			<b>No</b>	<b>No</b>	<b>Yes</b>	<b>Yes</b>
Diesel engine system various components	Cooling system	Inspect duct work clean louvers (8.1.2)	<b>No</b>	<b>No</b>	<b>Yes</b>	<b>Yes</b>
		Rod out heat exchanger (8.1.2)				
	Lubrication system	Oil change (8.1.2)				
		Oil filters (8.1.2)				
Exhaust system	Excessive back pressure (8.1.2)					
<b>C. Water Storage Tank</b>						
Water level (as required ) (9.4.2)			<b>Yes</b>	<b>Yes</b>	<b>Yes</b>	<b>Yes</b>
<b>SEMIANNUALLY (2)</b>						
Drain silt			<b>No</b>	<b>Yes<sup>5</sup></b>	<b>Yes</b>	<b>Yes</b>
<b>EVERY TWO (2) YEARS</b>						
Embankment-supported coated fabric (ESCF) suction tanks (9.4.6.2)			<b>No</b>	<b>No</b>	<b>Yes</b>	<b>Yes</b>
<b>D. Valve and Valve Component</b>						
<b>ANNUALLY (1)</b>						
Control valves (13.3.4)			<b>No</b>	<b>No</b>	<b>Yes</b>	<b>Yes</b>
Dry Pipe Valves and Quick-Opening Devices (13.4.4.3)			<b>No</b>	<b>No</b>	<b>Yes</b>	<b>Yes</b>

## 10.5 Inspection, Maintenance & Testing Notification Activities and Records

<b>Red Tag - Impairment</b>	- Notify FDNY & owner immediately (shall be fixed Immediately) FC 901.7
<b>Orange Tag - Critical Deficiency</b>	- Notify the owner immediately - If deficiency is not corrected after 30 days notify FDNY
<b>Yellow Tag - Non Critical Deficiency</b>	- Notify the owner immediately - If deficiency is not corrected after 30 days notify FDNY
<b>Green Tag - Fully Operational</b>	- System Fully operational

<u>Components</u>	<u>Inspection Activities</u> <u>(Reference NFPA 25 – 2011)</u>	<u>Tag Color</u>	<u>Repair Required?</u>	<u>If Yes, explain.</u>
<b>I. INSPECTION</b>				
<b>A. Standpipe &amp; Hose Systems</b>				
Standpipe system Shut down	Partial or Full shut down <b>(6.1)</b>	<b>Red</b>	<input type="checkbox"/> Yes <input type="checkbox"/> No	
No Access	Control Valves - Inaccessible for more than 30 days <b>(13.2.7.1)</b>	<b>Red</b>	<input type="checkbox"/> Yes <input type="checkbox"/> No	
Pipe and Fittings	Leaking <b>(5.2.2)</b>	<b>Red</b>	<input type="checkbox"/> Yes <input type="checkbox"/> No	
Hose	Cuts, couplings not of compatible threads <b>(6.2.1) NFPA 1962</b>	<b>Orange</b>	<input type="checkbox"/> Yes <input type="checkbox"/> No	
Hose	Deterioration, no gasket or damaged gaskets <b>(6.2.1) NFPA 1962</b>	<b>Orange</b>	<input type="checkbox"/> Yes <input type="checkbox"/> No	
Hose	Mildew present, corrosion present, hose not connected <b>(6.2.1) NFPA 1962</b>	<b>Yellow</b>	<input type="checkbox"/> Yes <input type="checkbox"/> No	
Hose nozzle	Missing, broken parts or thread gasket damaged <b>(6.2.1) NFPA 1962</b>	<b>Orange</b>	<input type="checkbox"/> Yes <input type="checkbox"/> No	
Hose storage	Hose not properly racked or rolled, nozzle clip missing, nozzle not contained, damaged obstructed <b>(6.2.1) NFPA 1962</b>	<b>Orange</b>	<input type="checkbox"/> Yes <input type="checkbox"/> No	
Cabinet	Corroded or damaged parts, not easy to open, not accessible, not identified, door glazing in poor condition, lock not functioning in break glass type, valve, hose nozzle, fire extinguisher, etc, not readily accessible <b>(6.2.1) NFPA 1962</b>	<b>Orange</b>	<input type="checkbox"/> Yes <input type="checkbox"/> No	
Pipe and fittings	Poor condition/external corrosion, mechanical damage, not properly aligned, external loads <b>(6.2.1)</b>	<b>Orange</b>	<input type="checkbox"/> Yes <input type="checkbox"/> No	
Pipe and fittings	Subject to freezing conditions <b>(6.2.1)</b>	<b>Orange</b>	<input type="checkbox"/> Yes <input type="checkbox"/> No	

<b>Components</b>	<b>Inspection Activities (Reference NFPA 25 – 2011)</b>	<b>Tag Color</b>	<b>Repair Required?</b>	<b>If Yes, explain.</b>
<b>I. INSPECTION</b>				
<b>A. Standpipe &amp; Hose Systems</b>				
Hangers & seismic braces	Damaged or loose (5.2.3)	Yellow	<input type="checkbox"/> Yes <input type="checkbox"/> No	
Gauges	Poor Condition (5.2.4.1)	Yellow	<input type="checkbox"/> Yes <input type="checkbox"/> No	
Gauges	Not showing normal water/air pressure (5.2.4.1, 5.2.4.2)	Orange	<input type="checkbox"/> Yes <input type="checkbox"/> No	
Building	Prior to freezing weather – exposed piping exposed to freezing (4.1.1.1)	Yellow	<input type="checkbox"/> Yes <input type="checkbox"/> No	
Building	Found during potential for freezing weather-exposed to freezing (4.1.1.1)	Orange	<input type="checkbox"/> Yes <input type="checkbox"/> No	
Alarm devices	Physical damage apparent (5.2.5)	Yellow	<input type="checkbox"/> Yes <input type="checkbox"/> No	
Hydraulic nameplate	Not legible or missing (5.2.6)	Yellow	<input type="checkbox"/> Yes <input type="checkbox"/> No	
<b>B. Private Fire Service Mains</b>				
Exposed piping	Leaking (7.2.2.1.2)	Red	<input type="checkbox"/> Yes <input type="checkbox"/> No	
Exposed piping	Mechanical damage, corroded or not properly restrained (7.2.2.1.2)	Orange	<input type="checkbox"/> Yes <input type="checkbox"/> No	
Mainline strainers	Plugged or fouled (7.2.2.3)	Red	<input type="checkbox"/> Yes <input type="checkbox"/> No	
Mainline strainers	Corroded (7.2.2.3)	Orange	<input type="checkbox"/> Yes <input type="checkbox"/> No	
Dry barrel, Wet barrel & wall hydrant	Inaccessible, barrel contains ice, cracks in barrel (7.2.2.4)	Red	<input type="checkbox"/> Yes <input type="checkbox"/> No	
Dry barrel, wet barrel & wall hydrant	Barrel contains water, improper drainage from barrel, leaks at outlets or top of hydrant (7.2.2.4)	Orange	<input type="checkbox"/> Yes <input type="checkbox"/> No	
Dry barrel, wet barrel & wall hydrant	Tightness of outlets, worn nozzle threads, worn operating nut, missing wrench (7.2.2.4)	Yellow	<input type="checkbox"/> Yes <input type="checkbox"/> No	
Monitor nozzles	Damaged, corroded or leaking (7.2.2.6)	Orange	<input type="checkbox"/> Yes <input type="checkbox"/> No	
Hose/hydrant houses	Inaccessible (7.2.2.7)	Red	<input type="checkbox"/> Yes <input type="checkbox"/> No	
Hose/hydrant houses	Damaged (7.2.2.7)	Orange	<input type="checkbox"/> Yes <input type="checkbox"/> No	
Hose/hydrant houses	Not fully equipped (7.2.2.7)	Yellow	<input type="checkbox"/> Yes <input type="checkbox"/> No	
<b>C. Fire and Special Service Pumps</b>				
Pump house/room	Heat not adequate, temperature. less than 40°F (less than 70 for diesel pumps without engine heaters) (8.2.2(1))	Orange	<input type="checkbox"/> Yes <input type="checkbox"/> No	
Pump house/room	Ventilating louvers not free to operate (8.2.2(1))	Orange	<input type="checkbox"/> Yes <input type="checkbox"/> No	

<b>Components</b>	<b>Inspection Activities (Reference NFPA 25 – 2011)</b>	<b>Tag Color</b>	<b>Repair Required?</b>	<b>If Yes, explain.</b>
<b>I. INSPECTION</b>				
<b>C. Fire and Special Service Pumps</b>				
Pump system	Suction, discharge or bypass valves not fully open, pipe leaking, suction line & system line pressure not normal, wet pit suction screens obstructed <b>(8.2.2(2))</b>	<b>Red</b>	<input type="checkbox"/> Yes <input type="checkbox"/> No	
Pump system	Suction reservoir not full, wet pit suction screens missing <b>(8.2.2(2))</b>	<b>Orange</b>	<input type="checkbox"/> Yes <input type="checkbox"/> No	
Electrical system	No electrical power - controller pilot light not illuminated, transfer switch pilot light not illuminated, isolating switch not closed, reverse phase alarm pilot light on or normal phase light is off, oil level in vertical motor sight glass not normal <b>(8.2.2(3))</b>	<b>Red</b>	<input type="checkbox"/> Yes <input type="checkbox"/> No	
Electrical system	Circuit breakers and fuses over two years old <b>(8.2.2)</b>	<b>Orange</b>	<input type="checkbox"/> Yes <input type="checkbox"/> No	
Electrical system	Electrical power is provided – controller pilot light not illuminated, transfer switch pilot light not illuminated, reverse phase alarm pilot light on or normal phase light is not illuminated <b>(8.2.2(3))</b>	<b>Yellow</b>	<input type="checkbox"/> Yes <input type="checkbox"/> No	
Diesel engine system	Fuel tank less than two-thirds full, controller selector switch not in auto position, battery voltage readings not normal, battery charging current not normal, battery pilot lights off or battery failure pilot lights on alarm pilot lights are on, engine running time meter not reading, oil level in right angle gear drive not normal, crankcase oil level not normal, cooling water level not normal, electrolyte level in batteries not normal, battery terminals corroded, water-jacket heater not operating <b>(8.2.2(4))</b>	<b>Orange</b>	<input type="checkbox"/> Yes <input type="checkbox"/> No	
Steam System	Steam pressure gauge reading not normal <b>(8.2.2(5))</b>	<b>Orange</b>	<input type="checkbox"/> Yes <input type="checkbox"/> No	

<b>Components</b>	<b>Inspection Activities (Reference NFPA 25 – 2011)</b>	<b>Tag Color</b>	<b>Repair Required?</b>	<b>If Yes, explain.</b>
<b>I. INSPECTION</b>				
<b>D. Water Storage Tanks</b>				
Water level	Water level and /or condition not correct <b>(9.2.1)</b>	<b>Orange</b>	<input type="checkbox"/> Yes <input type="checkbox"/> No	
Air pressure	Air pressure in pressure tanks not correct <b>(9.2.2)</b>	<b>Red</b>	<input type="checkbox"/> Yes <input type="checkbox"/> No	
Heating system	Heating system not operational, water temperature below 40 <b>(9.2.3)</b>	<b>Orange</b>	<input type="checkbox"/> Yes <input type="checkbox"/> No	
Exterior	Tank exterior, supporting structure, vents, foundation, catwalks or ladders where provided damaged <b>(9.2.5.1)</b>	<b>Yellow</b>	<input type="checkbox"/> Yes <input type="checkbox"/> No	
Exterior	Area around tank has fire exposure hazard in form of combustible storage, trash, debris, brush or material <b>(9.2.5.2)</b>	<b>Yellow</b>	<input type="checkbox"/> Yes <input type="checkbox"/> No	
Exterior	Accumulation of material on or near parts that could result in accelerated corrosion or rot <b>(9.2.5.2)</b>	<b>Yellow</b>	<input type="checkbox"/> Yes <input type="checkbox"/> No	
Exterior	Ice buildup on tank and support <b>(9.2.5.2)</b>	<b>Orange</b>	<input type="checkbox"/> Yes <input type="checkbox"/> No	
Exterior	Erosion exists on exterior sides or top of embankments supporting coated fabric tanks <b>(9.2.5.2)</b>	<b>Yellow</b>	<input type="checkbox"/> Yes <input type="checkbox"/> No	
Exterior	Expansion joints leaking or cracking <b>(9.2.5.3)</b>	<b>Orange</b>	<input type="checkbox"/> Yes <input type="checkbox"/> No	
Exterior	Hoops and grills of wooden tanks in poor condition <b>(9.2.5.4)</b>	<b>Yellow</b>	<input type="checkbox"/> Yes <input type="checkbox"/> No	
Exterior	Exterior painted, coated, or insulated surfaces of tanks or supporting structure degraded <b>(9.2.5.5)</b>	<b>Yellow</b>	<input type="checkbox"/> Yes <input type="checkbox"/> No	
Interior (pressure tanks or steel tanks w/o corrosion protection every 3 years, all others every 5 years)	Pitting, corrosion, spalling , rot other forms of deterioration, waste materials exist, aquatic growth, local or general failure of interior coating <b>(9.2.6.3)</b>	<b>Yellow</b>	<input type="checkbox"/> Yes <input type="checkbox"/> No	
Interior (pressure tanks or steel tanks w/o corrosion protection every 3 years, all others every 5 years)	Voided beneath floor with stand in the middle of tanks on ring type foundations <b>(9.2.6.5)</b>	<b>Yellow</b>	<input type="checkbox"/> Yes <input type="checkbox"/> No	
Interior (pressure tanks or steel tanks w/o corrosion protection every 3 years, all others every 5 years)	Heating system components or piping in poor condition <b>(9.2.6.6)</b>	<b>Yellow</b>	<input type="checkbox"/> Yes <input type="checkbox"/> No	



<b>Components</b>	<b>Inspection Activities (Reference NFPA 25 – 2011)</b>	<b>Tag Color</b>	<b>Repair Required?</b>	<b>If Yes, explain.</b>
<b>I. INSPECTION</b>				
<b>D. Water Storage Tanks</b>				
Interior (pressure tanks or steel tanks w/o corrosion protection every 3 years, all others every 5 years)	Blockage of anti-vortex plate <b>(9.2.6.7)</b>	<b>Red</b>	<input type="checkbox"/> Yes <input type="checkbox"/> No	
Interior (pressure tanks or steel tanks w/o corrosion protection every 3 years, all others every 5 years)	Deterioration of anti-vortex plate <b>(9.2.6.7)</b>	<b>Orange</b>	<input type="checkbox"/> Yes <input type="checkbox"/> No	
<b>E. Valves, Valve components, and Trim</b>				
Gauges	Poor condition <b>(13.2.7.1)</b>	<b>Yellow</b>	<input type="checkbox"/> Yes <input type="checkbox"/> No	
Gauges	Not showing normal water/air pressure <b>(13.2.7.1)</b>	<b>Orange</b>	<input type="checkbox"/> Yes <input type="checkbox"/> No	
Control valve	Improper closed position <b>(13.3.2.2)</b>	<b>Red</b>	<input type="checkbox"/> Yes <input type="checkbox"/> No	
Control valve	Improper open position, leaking <b>(13.3.2.2)</b>	<b>Orange</b>	<input type="checkbox"/> Yes <input type="checkbox"/> No	
Control valve	Not sealed, locked or supervised, not accessible, no appropriated wrench if required, and no identification <b>(13.3.2.2)</b>	<b>Yellow</b>	<input type="checkbox"/> Yes <input type="checkbox"/> No	
Alarm valve	External physical damage, trim valves not in appropriate open or closed position, retard chamber or alarm drain leaking <b>(13.4.1.1)</b>	<b>Orange</b>	<input type="checkbox"/> Yes <input type="checkbox"/> No	
Alarm valve	Alarm valve, strainers, filters and restricted orifices not internally inspected after 5 years <b>(13.4.1.2)</b>	<b>Orange</b>	<input type="checkbox"/> Yes <input type="checkbox"/> No	
Check valve	Check valve not internally inspected after 5 years <b>(13.4.2.1)</b>	<b>Orange</b>	<input type="checkbox"/> Yes <input type="checkbox"/> No	
Valve enclosure	Not maintaining minimum 40°F temp. <b>(13.4.3.1.1, 13.4.4.1.1)</b>	<b>Orange</b>	<input type="checkbox"/> Yes <input type="checkbox"/> No	
Deluge valve	External physical damage, trim valves not in appropriate open or closed position, valve seat leaking <b>(13.4.3.1.6)</b>	<b>Orange</b>	<input type="checkbox"/> Yes <input type="checkbox"/> No	
Deluge valve	Electrical components not in service <b>(13.4.3.1.6)</b>	<b>Red</b>	<input type="checkbox"/> Yes <input type="checkbox"/> No	
Deluge valve	Interior of pre-action valve/or deluge valve, strainers, filters, restricted orifices, and diaphragm chambers not internally inspected after 5 years <b>(13.4.3.1.8)</b>	<b>Orange</b>	<input type="checkbox"/> Yes <input type="checkbox"/> No	

<b>Components</b>	<b>Inspection Activities (Reference NFPA 25 – 2011)</b>	<b>Tag Color</b>	<b>Repair Required?</b>	<b>If Yes, explain.</b>
<b>I. INSPECTION</b>				
<b>E. Valves, Valve components, and Trim</b>				
Dry pipe valve/quick opening device (standpipe system)	External physical damage, trim valves not in appropriate open or closed position, intermediate chamber leaking <b>(13.4.4.1.4)</b>	<b>Orange</b>	<input type="checkbox"/> Yes <input type="checkbox"/> No	
Dry pipe valve/quick opening device	Dry pipe valve, strainers, filters and restricted orifices not internally inspected after 5 years <b>(13.4.4.1.6)</b>	<b>Orange</b>	<input type="checkbox"/> Yes <input type="checkbox"/> No	
Standpipe pressure regulating control valves	Not in open position, not maintaining down-stream pressures in accordance with the design criteria <b>(13.5.1.1)</b>	<b>Red</b>	<input type="checkbox"/> Yes <input type="checkbox"/> No	
FDNY 5 year test not conducted	As per Chapter 9 NYC Fire Code	<b>Orange</b>	<input type="checkbox"/> Yes <input type="checkbox"/> No	
Standpipe pressure regulating control valves	Leaking, valve damaged, hand wheel missing or broken <b>(13.5.1.1)</b>	<b>Orange</b>	<input type="checkbox"/> Yes <input type="checkbox"/> No	
Hose valves	Leaking, visible obstructions, caps, hose threads, valve handle, cap gasket, no restricting device, damaged or in poor condition <b>(13.5.6.1)</b>	<b>Orange</b>	<input type="checkbox"/> Yes <input type="checkbox"/> No	
Deluge valve	Annual partial flow test results not available <b>(13.5.1.3)</b>	<b>Orange</b>	<input type="checkbox"/> Yes <input type="checkbox"/> No	
Backflow prevention assemblies	Reduced pressure assemblies differential-sensing valve relief port continuously discharging <b>(13.6.1.2)</b>	<b>Orange</b>	<input type="checkbox"/> Yes <input type="checkbox"/> No	
Fire Department connection	Not accessible, couplings & swivels damaged, do not rotate smoothly, Fire department connection clapper not operating properly or missing, <b>(13.7.1)</b>	<b>Red</b>	<input type="checkbox"/> Yes <input type="checkbox"/> No	
Fire Department connection	Not visible, plugs & caps or gaskets damaged or missing, check valve leaking, automatic drain not operating properly or missing <b>(13.7.1)</b>	<b>Orange</b>	<input type="checkbox"/> Yes <input type="checkbox"/> No	
Fire Department connection	Missing identification sign <b>(13.7.1)</b>	<b>Yellow</b>	<input type="checkbox"/> Yes <input type="checkbox"/> No	

<b>Components</b>	<b>Inspection Activities (Reference NFPA 25 – 2011)</b>	<b>Tag Color</b>	<b>Repair Required?</b>	<b>If Yes, explain.</b>
<b>II. TEST</b>				
<b>A. Standpipe &amp; Hose Systems</b>				
Hose storage device	Rack will not swing out of cabinet at least 90° <b>(6.2.1, NFPA 1962)</b>	Yellow	<input type="checkbox"/> Yes <input type="checkbox"/> No	
Standpipe System	Test results did not provide design pressure at required flow <b>(6.3.1.1)</b>	Orange	<input type="checkbox"/> Yes <input type="checkbox"/> No	
Standpipe System	No flow test done after 5 years <b>(6.3.1.1)</b>	Yellow	<input type="checkbox"/> Yes <input type="checkbox"/> No	
Dry standpipe, dry portion of wet standpipe and manual standpipe system	Test showed leaks <b>(6.3.2)</b>	Orange	<input type="checkbox"/> Yes <input type="checkbox"/> No	
Dry standpipe, dry portion of wet standpipe and manual standpipe system	No hydrostatic test done after 5 years <b>(6.3.2)</b>	Yellow	<input type="checkbox"/> Yes <input type="checkbox"/> No	
Gauges	Not replaced or calibrated in 5 years, not accurate within 3% of scale <b>(5.3.2)</b>	Yellow	<input type="checkbox"/> Yes <input type="checkbox"/> No	
Alarm devices	Pressure switch or vane type switch not functioning or no alarm <b>(5.3.3)</b>	Orange	<input type="checkbox"/> Yes <input type="checkbox"/> No	
Obstruction Investigation	No inspection of main and branch line after 5 years or inspection revealed presence of MIC, zebra mussels, rust and scale <b>(14.3)</b>	Orange	<input type="checkbox"/> Yes <input type="checkbox"/> No	
<b>B. Private Fire Service Mains and fire and special service pumps</b>				
Underground and exposed piping	No flow test done after 5 years or test results not comparable to previous <b>(7.3.1)</b>	Yellow	<input type="checkbox"/> Yes <input type="checkbox"/> No	
Dry barrel & wall hydrant	Hydrant did not flow clear or did not drain within 60 minutes <b>(7.3.2.1, 7.3.2.4)</b>	Yellow	<input type="checkbox"/> Yes <input type="checkbox"/> No	
Monitor nozzles	Did not flow acceptable amount of water or did not operate throughout their full range <b>(7.3.3.1, 7.3.3.2)</b>	Orange	<input type="checkbox"/> Yes <input type="checkbox"/> No	
Fire pump weekly test	Pump did not start automatically, electric pump did not run 10 minutes, diesel pump did not run 30 minutes <b>(8.3.2.3, 8.3.2.4)</b>	Red	<input type="checkbox"/> Yes <input type="checkbox"/> No	
Fire pump weekly test – pump system	System suction and discharge gauge reading, or pump starting pressure not acceptable <b>(8.3.2.8(1))</b>	Red	<input type="checkbox"/> Yes <input type="checkbox"/> No	
Fire pump weekly test – pump system	Pump packing gland discharge not acceptable, unusual noise or vibration, packing boxes, bearings or pump casing overheating <b>(8.3.2.8(1))</b>	Orange	<input type="checkbox"/> Yes <input type="checkbox"/> No	

<b>Components</b>	<b>Inspection Activities (Reference NFPA 25 – 2011)</b>	<b>Tag Color</b>	<b>Repair Required?</b>	<b>If Yes, explain.</b>
<b>II. TEST</b>				
<b>B. Private Fire Service Mains and fire and special service pumps</b>				
Fire pump weekly test – electrical system	Time for motor to accelerate to full speed, time controller is on first step or time pump runs after starting not acceptable <b>(8.3.2.8(2))</b>	<b>Red</b>	<input type="checkbox"/> Yes <input type="checkbox"/> No	
Fire pump weekly test – diesel engine system	Time for engine to crank and time for engine to reach running speed not acceptable, low rpm, low oil pressure, high temperature, high cooling water pressure <b>(8.3.2.8(3))</b>	<b>Orange</b>	<input type="checkbox"/> Yes <input type="checkbox"/> No	
Fire pump weekly test- steam system	Gauge reading and time for turbine to reach running speed not acceptable <b>(8.3.2.8(4))</b>	<b>Red</b>	<input type="checkbox"/> Yes <input type="checkbox"/> No	
Fire pump annual test	Churn condition not maintained for 30 minutes, circulation relief valve and /or pressure relief valve <b>(8.3.3.2, 8.3.2.4)</b>	<b>Orange</b>	<input type="checkbox"/> Yes <input type="checkbox"/> No	
Fire pump annual test	Pressure relief valve did not work properly at each flow condition (8.3.3.3)	<b>Orange</b>	<input type="checkbox"/> Yes <input type="checkbox"/> No	
Fire pump annual test (with transfer switch)	Over current protective devices opened when simulating a power failure condition at peak load, power not transferred to alternate source, pump did not continue to perform at peak load, pump did not reconnect to normal power after removing power failure condition (8.3.3.4)	<b>Red</b>	<input type="checkbox"/> Yes <input type="checkbox"/> No	
Fire pump annual test	Alarms did not properly operate (8.3.3.5)	<b>Yellow</b>	<input type="checkbox"/> Yes <input type="checkbox"/> No	
Pump house/room	Heating lighting, ventilating systems did not pass test (8.3.4.3)	<b>Orange</b>	<input type="checkbox"/> Yes <input type="checkbox"/> No	
Fire pump annual test	Parallel or angular alignment was not correct (8.3.4.4)	<b>Orange</b>	<input type="checkbox"/> Yes <input type="checkbox"/> No	
Fire pump annual test	Flow test results are not within 5% of acceptance test or name plate (8.3.5.4)	<b>Orange</b>	<input type="checkbox"/> Yes <input type="checkbox"/> No	
Fire pump annual test	Voltage readings at the motor are not within 5 % below or 10% above the rated (name-plate) (8.3.5.6)	<b>Orange</b>	<input type="checkbox"/> Yes <input type="checkbox"/> No	

<b>Components</b>	<b>Inspection Activities (Reference NFPA 25 – 2011)</b>	<b>Tag Color</b>	<b>Repair Required?</b>	<b>If Yes, explain.</b>
<b>II. TEST</b>				
<b>C. Water Storage Tanks</b>				
Interior testing	Tank coating did not pass adhesion, coating thickness or wet sponge test <b>(9.2.7)</b>	<b>Yellow</b>	<input type="checkbox"/> Yes <input type="checkbox"/> No	
Interior testing	Tank walls and bottom did not pass ultrasonic test <b>(9.2.7)</b>	<b>Yellow</b>	<input type="checkbox"/> Yes <input type="checkbox"/> No	
Interior testing	Tank bottom seams did not pass vacuum box test <b>(9.2.7)</b>	<b>Yellow</b>	<input type="checkbox"/> Yes <input type="checkbox"/> No	
Testing	Level indicator not tested after 5 years, lacked freedom of movement or not accurate <b>(9.3.1)</b>	<b>Yellow</b>	<input type="checkbox"/> Yes <input type="checkbox"/> No	
Testing	Low water temperature alarm did not pass test <b>(9.3.3)</b>	<b>Yellow</b>	<input type="checkbox"/> Yes <input type="checkbox"/> No	
Testing	High water temperature limit switch did not pass test <b>(9.3.4)</b>	<b>Yellow</b>	<input type="checkbox"/> Yes <input type="checkbox"/> No	
Testing	High and low water level alarms did not pass test <b>(9.3.5)</b>	<b>Orange</b>	<input type="checkbox"/> Yes <input type="checkbox"/> No	
Gauges	Not tested in 5 years, not accurate within 3% of scale <b>(9.3.6)</b>	<b>Yellow</b>	<input type="checkbox"/> Yes <input type="checkbox"/> No	
<b>D. Foam-Water Standpipe Systems</b>				
Alarm devices	Water motor and gong not functioning <b>(11.1.3.1.1, 11.3.1.1)</b>	<b>Orange</b>	<input type="checkbox"/> Yes <input type="checkbox"/> No	
Alarm devices	Pressure switch or van type switch not functioning or no alarm <b>(11.1.3.1.2, 11.3.1.2)</b>	<b>Orange</b>	<input type="checkbox"/> Yes <input type="checkbox"/> No	
Operational Test	Fire detection system did not operate within requirements of NFPA #72 <b>(11.3.2.4)</b>	<b>Orange</b>	<input type="checkbox"/> Yes <input type="checkbox"/> No	
Operational Test	Test not done after 1 year <b>(11.3)</b>	<b>Yellow</b>	<input type="checkbox"/> Yes <input type="checkbox"/> No	
Operational Test	Nozzles are plugged <b>(11.3.2.6.1)</b>	<b>Red</b>	<input type="checkbox"/> Yes <input type="checkbox"/> No	
Operational Test	Nozzles are not correctly positioned <b>(11.3.2.6.1)</b>	<b>Orange</b>	<input type="checkbox"/> Yes <input type="checkbox"/> No	
Operational Test	Pressure readings are not comparable to original design requirements <b>(11.3.2.7.3)</b>	<b>Orange</b>	<input type="checkbox"/> Yes <input type="checkbox"/> No	
Operational Test	Manual actuation devices did not work properly <b>(11.3.4)</b>	<b>Red</b>	<input type="checkbox"/> Yes <input type="checkbox"/> No	
Operational Test	Foam sample did not pass concentration test <b>(11.3.5)</b>	<b>Red</b>	<input type="checkbox"/> Yes <input type="checkbox"/> No	
Obstruction Investigation	No inspection of main and branch line after 5 years or inspection revealed presence of MIC, zebra mussels, rust and scale <b>(14.3)</b>	<b>Orange</b>	<input type="checkbox"/> Yes <input type="checkbox"/> No	

<b>Components</b>	<b>Inspection Activities (Reference NFPA 25 – 2011)</b>	<b>Tag Color</b>	<b>Repair Required?</b>	<b>If Yes, explain.</b>
<b>II. TEST</b>				
<b>E. Valves, Valve components, and Trim</b>				
Alarm devices	Water motor and gong not functioning <b>(13.2.6.1)</b>	Orange	<input type="checkbox"/> Yes <input type="checkbox"/> No	
Alarm devices	Pressure switch or vane type switch not functioning or no alarm <b>(13.2.6.2)</b>	Orange	<input type="checkbox"/> Yes <input type="checkbox"/> No	
Gauges	not replaced or calibrated in 5 years, not accurate within 3% of scale <b>(13.2.7.2,13.2.7.3)</b>	Yellow	<input type="checkbox"/> Yes <input type="checkbox"/> No	
Control valve	Valve will not operate through its full range <b>(13.3.3.1)</b>	Orange	<input type="checkbox"/> Yes <input type="checkbox"/> No	
Control valve	No spring or torsion felt in rod when opening post indicator valve <b>(13.3.3.2)</b>	Red	<input type="checkbox"/> Yes <input type="checkbox"/> No	
Supervisory switches	No signal from two revolutions of the hand wheel from normal position or when stem has moved 1/5 of the distance from normal position, signal restored in position other than normal <b>(12.3.3.5.2)</b>	Yellow	<input type="checkbox"/> Yes <input type="checkbox"/> No	
Preaction valve	Priming water level not correct <b>(12.4.3.2.1)</b>	Orange	<input type="checkbox"/> Yes <input type="checkbox"/> No	
Deluge valve	Annual full flow trip test revealed plugged nozzles, pressure reading at hydraulically most remote nozzle and/or at valve not comparable to original design values, manual actuation devices did not operate properly <b>(13.4.3.2.2.3)</b>	Red	<input type="checkbox"/> Yes <input type="checkbox"/> No	
Preaction Valve	Low air pressure switch not tested quarterly <b>(13.4.3.2.13)</b>	Yellow	<input type="checkbox"/> Yes <input type="checkbox"/> No	
Deluge valve	Low temperature switch did not send signal or no alarm <b>(13.4.3.2.14)</b>	Yellow	<input type="checkbox"/> Yes <input type="checkbox"/> No	
Preaction valve	Automatic air maintenance device did not pass test <b>(13.4.3.2.15)</b>	Yellow	<input type="checkbox"/> Yes <input type="checkbox"/> No	
Dry pipe valve	Priming water level not correct <b>(13.4.4.2.1)</b>	Orange	<input type="checkbox"/> Yes <input type="checkbox"/> No	
Dry pipe valve	Annual trip test results were not comparable to previous tests <b>(13.4.4.2.2)</b>	Yellow	<input type="checkbox"/> Yes <input type="checkbox"/> No	
Dry pipe valve	No full flow trip test done after 3 years <b>(13.4.4.2.2.2)</b>	Yellow	<input type="checkbox"/> Yes <input type="checkbox"/> No	
Quick opening device	Quick opening device did not pass test <b>(13.4.4.2.4)</b>	Orange	<input type="checkbox"/> Yes <input type="checkbox"/> No	
Dry pipe valve	Low air pressure switch did not send signal or no alarm <b>(13.4.4.2.6)</b>	Yellow	<input type="checkbox"/> Yes <input type="checkbox"/> No	
Dry pipe valve	Low temperature switch did not send signal or no alarm <b>(13.4.4.2.7)</b>	Yellow	<input type="checkbox"/> Yes <input type="checkbox"/> No	
Dry pipe valve	Automatic air maintenance device did not pass test <b>(13.4.4.2.8)</b>	Orange	<input type="checkbox"/> Yes <input type="checkbox"/> No	

<b>Components</b>	<b>Inspection Activities (Reference NFPA 25 – 2011)</b>	<b>Tag Color</b>	<b>Repair Required?</b>	<b>If Yes, explain.</b>
<b>II. TEST</b>				
<b>E. Valves, Valve components, and Trim</b>				
Standpipe pressure reducing control valves	No full flow test done after 5 years or test results not comparable to previous results <b>(13.5.1.2)</b>	<b>Yellow</b>	<input type="checkbox"/> Yes <input type="checkbox"/> No	
Hose valves(Class I & Class III Standpipe system)	Annual test revealed valve leaking or difficult to operate <b>(13.5.6.2.1.1)</b>	<b>Orange</b>	<input type="checkbox"/> Yes <input type="checkbox"/> No	
Hose valves	Cap missing <b>(13.5.2.1)</b>	<b>Yellow</b>	<input type="checkbox"/> Yes <input type="checkbox"/> No	
Hose valves	Thread damaged <b>(13.6.1.2)</b>	<b>Orange</b>	<input type="checkbox"/> Yes <input type="checkbox"/> No	
Hose valves	Wheel handle broken or missing <b>(not applied to NYCHA)</b>	<b>Orange</b>	<input type="checkbox"/> Yes <input type="checkbox"/> No	
Backflow prevention assemblies	Did not pass forward flow test <b>(13.6.2.1)</b>	<b>Red</b>	<input type="checkbox"/> Yes <input type="checkbox"/> No	
Backflow prevention assemblies	No forward flow test done after one year <b>(13.6.2.1)</b>	<b>Yellow</b>	<input type="checkbox"/> Yes <input type="checkbox"/> No	

## **PART 11: SIGNAGE REQUIREMENTS**

All **interior** signage shall have a **red background** with minimum 1 inch high **white letters**. All **exterior** signage shall have a **white background** with minimum 1 inch high **red letters**. (NYC Building Code and NYC FD Code)

### **11.1 Fire Department connection sign**



### **11.2 Control valve sign**



### **11.3 Stand Pipe System Shutoff sign**



### **11.4 Fire Department connections serving a standpipe system sign**

Fire Department connections servicing a standpipe system shall be provide with caps painted red, and shall have word



### **11.4 Standpipe systems type sign**





**11.5 Supply Hose sign**

Hose marked "SUPPLY HOSE" shall not be used at operating pressures exceeding 185 psi



**11.6 Stairways without hose connections sign**

Stairways without hose connections shall have a sign on the door to the stairway stating.



**11.7 Fire Hose sign**

If the hoses are installed in cabinets each cabinet should be labeled, indoor sign, letters must be at least two inches high:



**11.8 On Dry Standpipe with no Permanent Water Supply Sign**

This system is usually used in a building that is not heated such as unoccupied buildings and parking garage structures. On this system a sign must be attached to each of the hose outlets. It should read:



## PART 12: NYC Building LOCAL LAW 58 OF 2009



# STANDPIPES + SPRINKLERS New Safety Regulations

**New standpipe and sprinkler piping laws go into effect in 2010. Building owners and contractors must be sure their properties and projects comply with these new local laws.**

The Buildings Department participated in the multi-agency advisory group that proposed these new safety standards. Mayor Michael R. Bloomberg appointed Deputy Mayor Edward Skyler to lead the Construction, Demolition and Abatement Working Group, which generated 33 safety recommendations – including the four local laws described here.

To learn more, read *Strengthening the Safety, Oversight and Coordination of Construction, Demolition and Abatement Operations*, available at [nyc.gov/buildings](http://nyc.gov/buildings).

### CUTTING AND CAPPING Local Law 60/09, effective 3/2/2010.

Permits are required to cut and cap standpipes or sprinklers.

- Authorized Licensees: Only licensed master plumbers or licensed master fire suppression piping contractors may cut and cap standpipes or sprinklers during demolition.
- Local Law Incorporates TPPN 3/07: For demolitions and gut rehabilitations, a registered design professional must have a variance to remove damaged or inoperable sprinklers. This filing must include a damage report and explanation why the system can't be restored. (The design professional must first file the variance with the Fire Department and have FDNY approval before filing it with the Buildings Department.)

### COLOR CODING Local Law 58/09, effective 3/2/2010.

**Existing buildings must comply by 6/2/2010.**

All exposed standpipes and sprinkler piping must be painted red. The law outlines specific exceptions, such as branch piping.

All buildings – no matter the size or occupancy – must comply with these new requirements.

### COLOR CODING CERTIFICATION

#### Buildings Under Construction

The special inspector will confirm compliance before the walls are enclosed.

#### Existing Buildings

Owners of buildings with exposed sprinkler piping and standpipes must comply and hire one of four types of contractors to certify the color coding:

- Licensed master plumbers;
- Licensed master fire suppression piping contractors;
- Registered design professionals; or
- People with the appropriate Fire Department Certificate of Fitness.

### PROOF OF COLOR CODING CERTIFICATION

The color coding certification must be kept on the premises at all times for Buildings and Fire Department inspection. Visit [nyc.gov/buildings](http://nyc.gov/buildings) for the certification form, available online in March 2010. (over)

Dedicated standpipe valve handles must be painted **red**.



Combination standpipe valve handles must be painted **yellow**.



Dedicated sprinkler valve handles must be painted **green**.



Robert D. LiMandri, Commissioner

Michael R. Bloomberg, Mayor

## **PART 13: Fire Department Code and Rules Chapter 9**

---

### **13.1 Fire Department Code Section 905 Standpipe System**

#### **SECTION FC 905 STANDPIPE SYSTEMS**

**905.1 General.** Standpipe systems shall be provided where required by the construction codes, including the Building Code, this code or the rules. Fire hose threads used in connection with standpipe systems shall be approved by the commissioner. The location of fire department hose connections shall be approved by the commissioner. Standpipe systems in buildings used for high-piled combustible storage shall be in accordance with FC Chapter 23.

**905.1.1 Standpipe system operator.** In buildings with a multi-zone standpipe system, such system shall be **continuously under the personal supervision** of a person holding a C of F, who shall be immediately available to assist the department in the operation of such system.

**905.2 Installation standards.** Standpipe systems shall be installed in accordance with the construction codes, including the Building Code.

**905.3** through and including **905.6** Reserved.

**905.7 Cabinets.** Cabinets containing firefighting equipment, such as standpipes, fire hose, portable fire extinguishers and water supply control valves, shall not be obstructed from use or obscured from view.

**905.8** Reserved.

**905.9 Valve supervision.** Valves controlling water supplies shall be supervised in the open position so that a change in the normal position of the valve will generate a supervisory signal at the central station required by FC Section 903.4. Where a fire alarm system is provided, a signal shall also be transmitted to the fire alarm system control panel.

**Exceptions:**

1. Valves to underground key or hub valves in roadway boxes provided by the municipality or public utility do not require supervision.
2. Valves locked in the normal position and inspected as provided in this code in buildings not equipped with a fire alarm system.

**905.10 During construction.** Standpipe systems required during construction, alteration and demolition operations shall be provided in accordance with Chapter 33 of the Building Code and FC Section 1413.

**905.11** Reserved.

**905.12 Maintenance.** Standpipe systems shall be maintained, including all required inspection, testing and servicing, in accordance with this section, FC Section 901.6 and NFPA 25.

**905.12.1 Standpipe hydrostatic pressure and flow tests.** Upon order of the commissioner, but at least once every 5 years, the standpipe system shall be subjected to a hydrostatic pressure test and a flow test to demonstrate its suitability for department use. These tests shall be conducted in compliance with the requirements

of the rules and shall be conducted at the owner's risk, by his or her representative before a representative of the department.

## **13.2 Fire Department Rules § 905-01 Standpipe System**

### **§ 905-01 Standpipe System Pressure Reducing Devices**

- (a) **Scope.** This section sets forth requirements for *standpipe system* pressure reducing devices.
- (b) **Definitions.** The following terms shall, for purposes of this section and used elsewhere in the *rules*, have the meanings shown herein:
  - Pressure reducing devices.** Devices, including valves, installed in *standpipe systems* at or near hose outlet connections that act to limit both the static and dynamic water pressures downstream of the standpipe outlet valve.
  - Pressure restrictors.** Removable fittings or "SECO Type" valves that restrict flowing water pressures by reducing the available cross-sectional area of flow.
- (c) **General Provisions**
  - (1) Certificate of approval. *Pressure reducing devices* installed in a *standpipe system* shall be of an approved type and for which a *certificate of approval* has been issued.
- (d) **Pressure Reducing Device Requirements.**
  - (1) Location and pressure markings. Each *pressure reducing device* shall be permanently marked with the address of the *premises* in which it is installed, its floor location, and its designated pressure setting.
  - (2) Adjustments and reporting. Upon initial installation of a *pressure reducing device*, and at least once every three (3) years thereafter, a master fire suppression contractor shall file an affidavit with the *Department* on behalf of the building *owner* attesting to the following:
    - (A) The building address and *owner's* name.
    - (B) The floor location of all *standpipe system pressure reducing devices* and the inlet pressure (static and operating) of each device.
    - (C) The setting of each device and the corresponding discharge flow rate (*gpm*), discharge pressure (*psig*), and the maximum outlet static pressure (*psig*).
    - (D) The name, address, and master fire suppression contractor license number of the person submitting the affidavit.
  - (3) **Flow testing.** Upon order of the *Commissioner*, but at least once every three (3) years, *standpipe systems* with *pressure reducing devices* installed shall be flow tested with a minimum actual flowing discharge of 250 *gpm*. These tests shall be conducted by a master fire suppression contractor who shall provide the *Department* five (5) business days notice of the date and time of the test. The *Department* may witness these tests at its discretion.

## **PART 14: LIST OF MAJOR CHANGES IN NEW S-13**

### **1. ADJUSTED REFERENCES AND INFORMATION TO REFLECT NFPA 25 STANDARD, 2011 EDITION. NFPA REFERENCES HAVE BEEN ADDED TO THE REFERENCE GUIDE OF THE NEW STUDY MATERIAL.**

2. Added on cover page: combined sprinkler/standpipe systems a valid S-12/S-15 is also required.

### **3. NEW DEFINITIONS:**

ALARM NOTIFICATION APPLIANCE

ALARM SIGNAL

AUTOMATIC BALL DRIP

CENTRAL STATION

COMBINATION STANDPIPE AND SPRINKLER SYSTEM

OS & Y VALVE

CURB VALVE

CRITICAL DEFICIENCY

NON CRITICAL DEFICIENCY

FIRE ALARM SYSTEM

FIRE PROTECTION SYSTEM

FIRE PUMP, AUTOMATIC STANDPIPE

FIRE PUMP, FOAM

FIRE PUMP, LIMITED SERVICE

FIRE PUMP, SPECIAL SERVICE

HYDRAULIC PLACARD

HYDRAULICALLY CALCULATED SYSTEMS

IMPAIRMENT

MAIN DRAIN

MICROBIOLOGICALLY INFLUENCES CORROSION

PERSONAL SUPERVISION

4. Under 7.1 overview of standpipe systems, added information about multi-zone system.
5. Manual Wet Standpipe System section has been added from NFPA 14.
6. Changed Class III description to reflect NFPA 25 under 7.2 Classes of Standpipe Systems.
7. Under fire pumps, new description of the centrifugal pump has been added.
8. Pump activation section has been altered to reflect changes.
9. Highlighted information in Part 10 (frequency table) is new.