

MAY 2026

COURSE OF FIRE

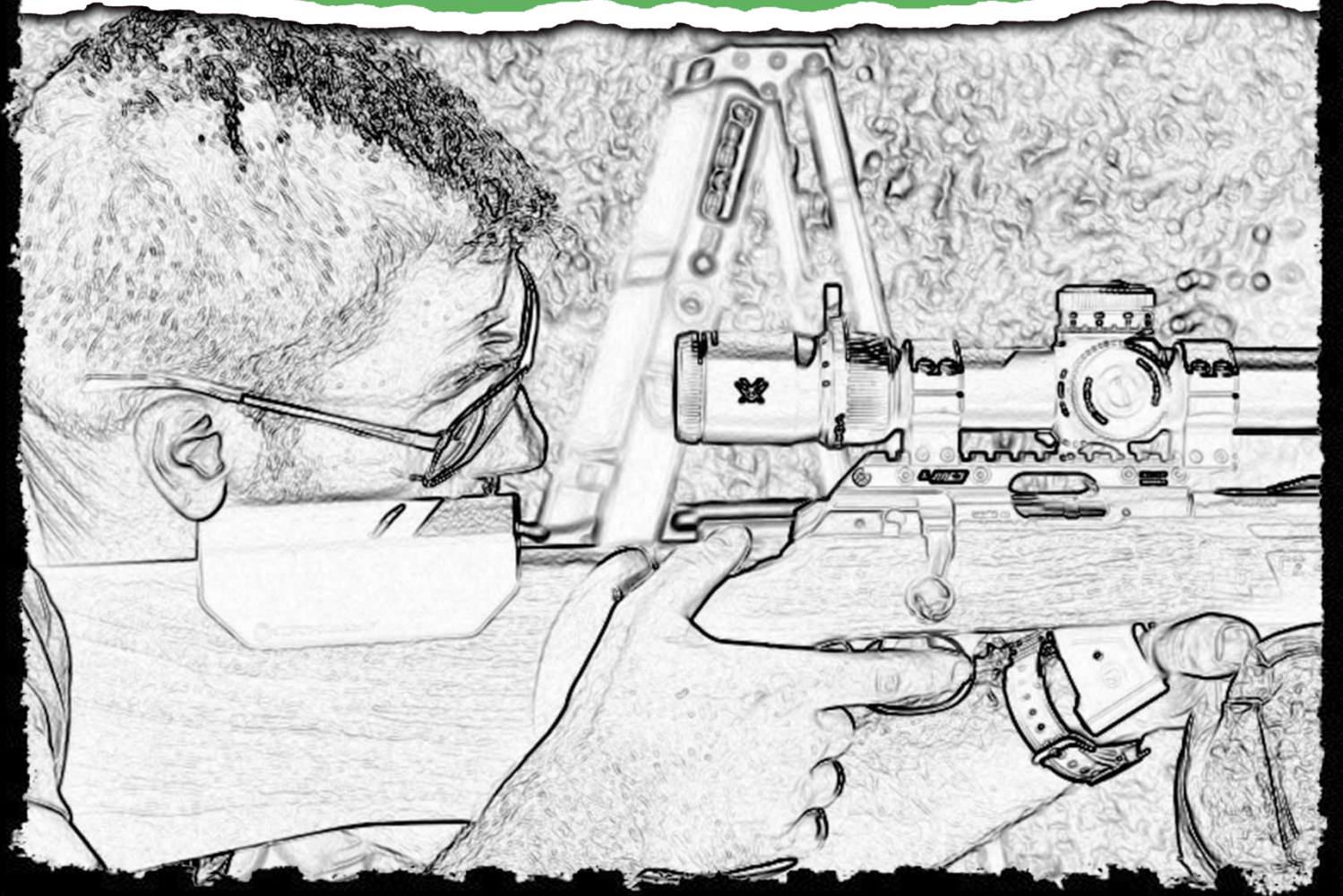
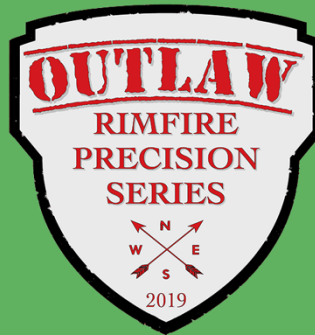

RANGE REQUIREMENTS:

TARGETS:

KYL RACK – 1", .75", .50", .25"

1 X 1" TARGET

1 X 1.5" TARGET

1 X 2.0" TARGET

2 X 2.5" TARGET

1 X 3" TARGET

1 X 4" TARGET

1 X 5" TARGET

PROPS:

- FOLDING CHAIR
- 4 TIRES
- 5 – GALLON BUCKET – OPEN SIDE UP, EMPTY WITH NO OBJECTS/WEIGHTS INSIDE
- 6-FOOT STEPLADDER

UNLESS OTHERWISE STATED MULTIPLE TARGETS IN THE SAME STAGE ARE TO BE SEPARATED WITH A 5 YARD LATERAL SPACING.

ALL POSITION TRANSITIONS MUST BE DONE WITH THE BOLT BACK FOR BOLT ACTION RIFLES. SEMI-AUTO SHOOTERS MUST ENGAGE THE SAFETY AND DECLARE "SAFE" BEFORE TRANSITION BEGINS.

AT THE END OF A STAGE ALL RIFLES MUST BE INSPECTED AND DECLARED CLEAR WITH CHAMBER FLAGS INSERTED BEFORE SHOOTER IS ALLOWED TO DEPART THE FIRING POINT

Safety

General Rifle Safety

1. Always point your rifle in a safe direction. Never point a rifle at anything you don't intend to destroy.
2. Always keep your rifle unloaded until ready to use. Treat all rifles as though they are loaded even if you believe otherwise.
3. Keep your finger out of the trigger guard until you are ready to fire.
4. Know your target and what is beyond.

Rifle Safety During an OPRS Match

1. OPRS competitions are always cold ranges. All rifles are to be unloaded, with magazines out, actions open and chamber flags inserted. Rifles shall only be loaded or have magazines inserted when directed by the Range Officers at the firing point of the stage.
2. Chamber flags shall be utilized and kept in the action until directed by the Range Officer. Weed trimmer string in a bright colour is a suitable chamber flag.
3. There will be no manipulation of the bolt, action or trigger outside of the designated safe areas.
4. When moving to another shooting location, always ensure the chamber flag is in place and that the rifle is pointed in a safe direction.
5. Competitors may not take a sight picture at a stage using firearms before shooting the stage.

Rifle Safety During Your Stage

1. Always wait for the Range Officer's command of "load and stand ready" before you insert the magazine and remove the chamber flag.
2. Stages always begin with the magazine in and bolt to the rear with an empty chamber (if unable to put the bolt to the rear) unless specifically directed by the match booklet and the Range Officer. Semi-auto rifles MUST have their safety engaged until directed by the Range Officer.
3. Any movement or barricade transitions with bolt action rifles must be done with the action open and an empty chamber. Shooters with semi-auto rifles must engage the safety, and declare "safe" to the RO before any movement.
4. During movement, the 120° rule must always be adhered to. The 120 rule refers to only pointing the rifle within 60° of straight forward. Always follow directions and be aware of where you are pointing your rifle.

RO and Range Commands

1. Do you understand the course of fire?

RO will ask this question to make sure you understand the stage and which targets you need to engage and in which order. If you have any questions, this is the last time you can clarify before the stage begins.

2. Shooter, insert the magazine and stand ready!

When the RO issues this command, you may insert your magazine into the rifle and remove the chamber flag without closing the bolt.

3. Spotter Ready, Shooter Ready, Standby!

When the RO issues this command you are being instructed to get ready for the start of the stage.

4. ENGAGE!

After the RO issues this command, your stage timer has started. You must move to the firing line and get in position to engage your first target. You can only close your bolt or remove your safety when you are in position and on target.

5. STOP!

When this command is issued you must stop shooting immediately, and wait for a subsequent command.

6. Unload and show clear

When the RO issues this command, you must open the bolt, remove the magazine, and insert a chamber flag into your chamber.

7. CLEAR!

Your rifle is now clear, and you can move off the shooting line.

Stage 1: Barrels of Fun

Barricade/Prop: 55 Gal Barrel
Shooting Position : From top surface of barrel
 – 2 positions

Round Count: 8
Scoring: 10 pts/Hit
Possible Points: 80

Bipod/Bag Allowed: Yes

Must Hit to Advance: No

Par Time: 120 Seconds

	Size/Shape	Yards/Meters
T1	1.0"	25/23
T2	0.75"	25/23
T3	0.5"	25/23
T4	0.25"	25/23

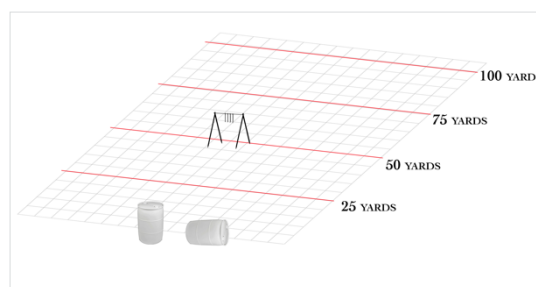

Start Position:

Standing 1 yard behind firing point, mag in, bolt back, chamber flag removed.
 Close the bolt only when you get in position

On the Engage command adopt the shooting position from the top of the barrel, engaging T1 to T4 with 1 round each. Hit or miss, after 4 rounds, shooter safely grounds rifle and lays 55gal barrel to the right (parallel to the firing line) and re-engages T1 to T4 with 1 round each.

Shooter continues until rounds complete or time expires.

Stage 2: Chair Work

***** TIMED STAGE *****

Record time elapsed NOT time remaining

Barricade/Prop:	Folding Chair	Round Count:	10
Shooting Position:	Top of chair back and from seat.	Scoring:	10 pts/hit
Bipod/Bag Allowed:	Yes	Possible points:	100
Must Hit to Advance:	No		
Par Time:	120 Seconds		

	Size/Shape	Yards/Meters
T1	3.0"	50/46
T2	1.5"	100/92

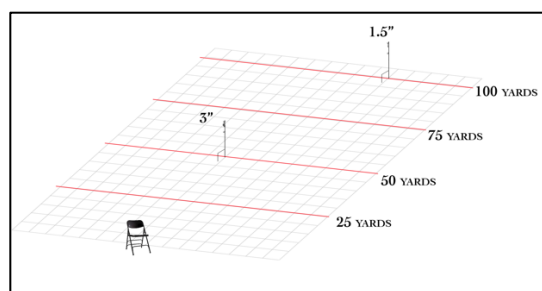

Start Position:

Standing 1 yard behind firing point, mag in, bolt back, chamber flag removed.
Close the bolt only when you get in position

On the Engage command shooter adopts the firing position with rifle supported from the top of the chair back (chair facing sideways towards right of range) and engages T1 with 3 rounds. Hit or miss, shooter transitions to a position with rifle supported on chair seat and engages T2 with 3 rounds. Hit or miss, shooter returns to a position with rifle supported on the chair back engaging T1 with 2 rounds and T2 with 2 rounds, hit or miss.

Shooter continues until rounds complete or time expires.

Transitions must be done with the bolt back for bolt action rifles. Semi-auto shooters must engage safety and declare "SAFE" before transitions.

Time is recorded for this stage. Please record time elapsed not time remaining.

Stage 3: Shift and Shoot

Barricade/Prop: 3 different tire stacks
Shooting Position: From top of tires in each pile
Bipod/Bag Allowed: Yes – Bipod and only 1 bag roughly size of volleyball
Must Hit to Advance: No
Par Time: 120 Seconds

Round Count: 12
Scoring: 10pts/hit
Possible Points: 120

	Size/Shape	Yards/Meters
T1	2.5"	50/46
T2	2.0"	75/69

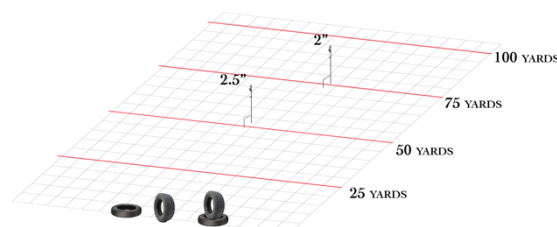

Start Position:

1 yard behind firing point, mag in, bolt back, chamber flag removed.

Close the bolt only when you get in position and sights are on the target.

On the engage command shooter adopts the shooting position from the top surface of the first tire on the left and engages T1 with 2 rounds and T2 with 2 rounds. Hit or miss, shooter then transitions to middle tire and engages T1 and T2 again with 2 rounds each. Hit or miss, shooter finally transitions to the third tire pile and reengages T1 and T2 again with 2 rounds each. MD may choose to stabilize the solo standing tire as needed to ensure safety.

Transitions must be done with the bolt back for bolt action rifles. Semi-auto shooters must engage safety and declare "SAFE" before transitions.

Stage 4: Open Bucket Challenge

Barricade/Prop: 5 Gallon bucket – open top up
Shooting Position: from bucket edge
Bipod/Bag Allowed: Yes
Must Hit to Advance: Yes
Par Time: 120 Seconds

Round Count: 8
Scoring: 10 pts/hit
Possible Points: 80

	Size/Shape	Yards/Meters
T1	5"	50/46
T2	2.5"	100/92

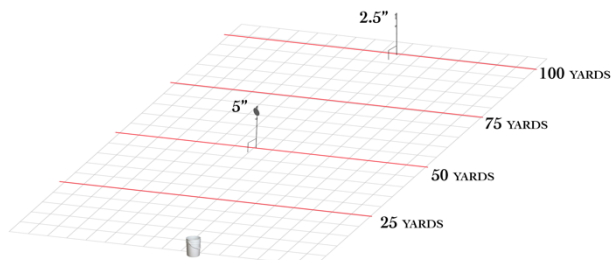

Start Position:

Standing 1 yard behind firing point, mag in, bolt back, chamber flag removed.
 Close the bolt only when you get in position

On the Engage command shooter moves to the firing point and adopts a shooting position from the left side of the bucket rim and engages T1 with 2 hits. Once 2 hits are made, shooter engages T2 until 2 hits are made. Once 2 hits are made on T2, shooter transitions to rim on right side of the bucket. Shooter then re-engages T1 to get 2 hits before engaging T2 for 2 hits.

Transitions must be done with the bolt back for bolt action rifles. Semi-auto shooters must engage safety and declare "SAFE" before transitions.

Shooter continues until rounds complete or time expires.

Stage 5: Ladder Up!

Barricade/Prop: 6-foot Step Ladder
Shooting Position : Start Bottom Step
 1 step at a time
Bipod/Bag Allowed: Yes
Must Hit to Advance: No
Par Time: 120 Seconds

Round Count: 10
Scoring: 10 pts/hit
Possible Points: 100

	Size/Shape	Yards/Meters
T1	4"	100/92
T2	1"	50/46

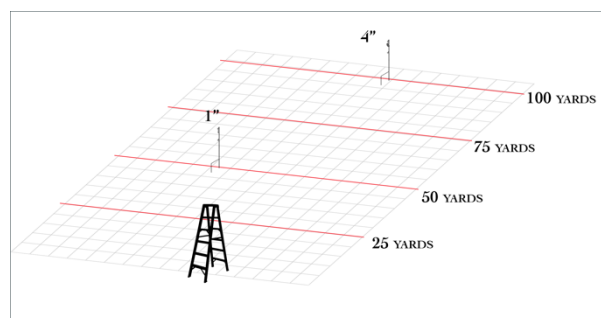

Start Position:

Standing at firing point, rifle in hand, mag in, bolt back, chamber flag removed.
 Close the bolt only when you get in position

On the Engage command shooter adopts a position from the bottom step and engages T1 and T2 with 1 round each (Far to Near), hit or miss. After 2 rounds, shooter transitions to the 4th step from the bottom and engages T1 and T2 (Far to Near) with round each, hit or miss. After 2 rounds, shooter transitions to the 2nd from the bottom step and engages T2 and T1 (Near to Far) with 1 round each, hit or miss. After 2 rounds shooter transitions to the 3rd step from the bottom and engages T2 and T1 (Near to Far) with 2 rounds each, hit or miss.

Transitions must be done with the bolt back for bolt action rifles. Semi-auto shooters must engage safety and declare "SAFE" before transitions.

Shooter continues until rounds complete or time expires.