

**TRANSMISSION LINE
CONDUCTOR STRINGING,
TOWER ERECTION TOOLS
AND EQUIPMENTS**

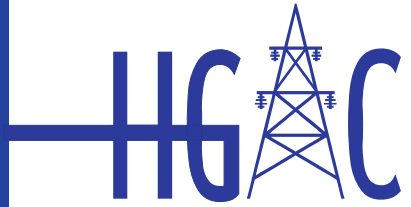

**INTEGRITY SAFETY QUALITY
PRODUCTIVITY INNOVATION**

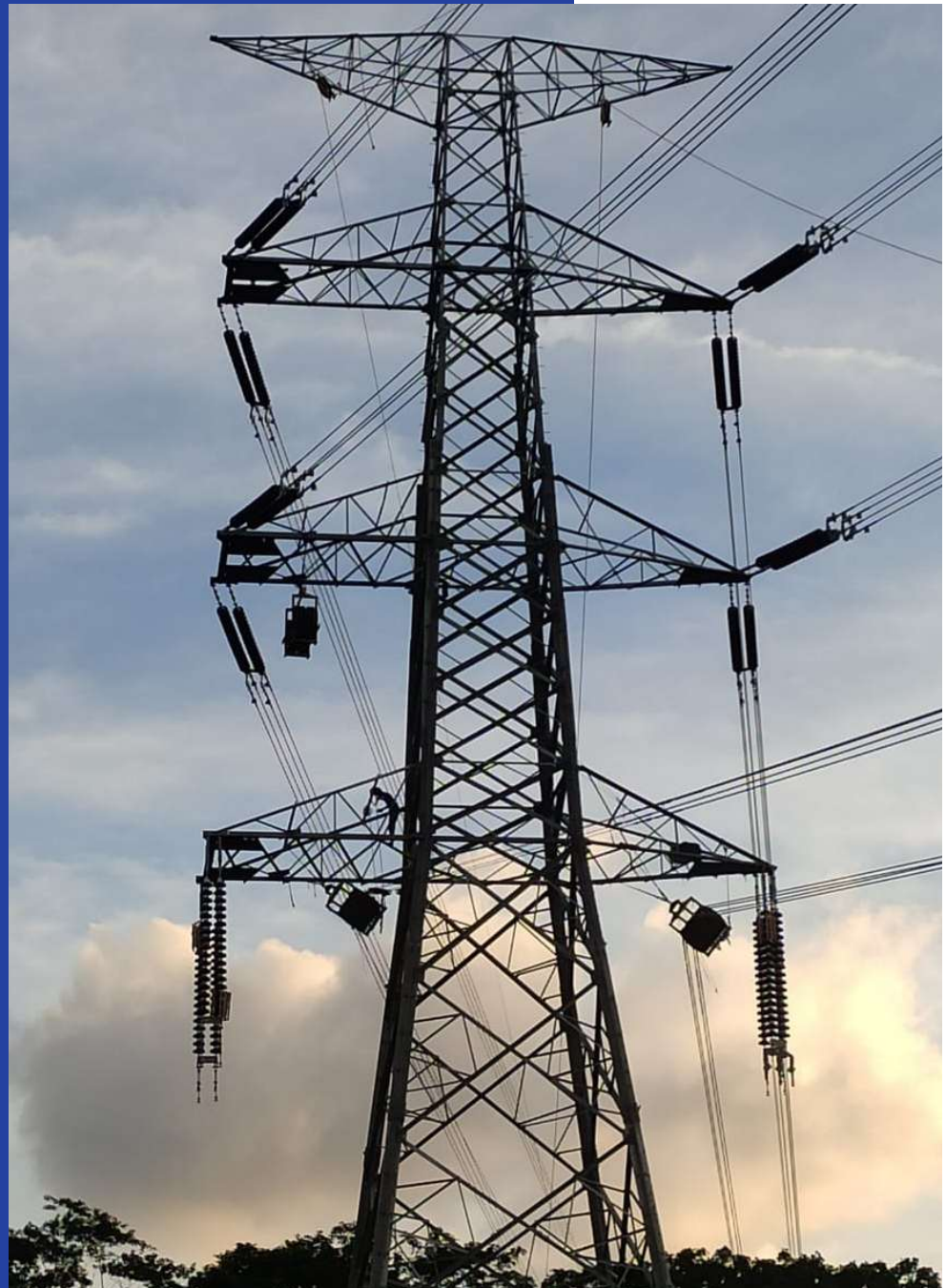

HIND GOLD AUTOMOTIVE COMPONENTS





Our Clients



About Us Since 1968

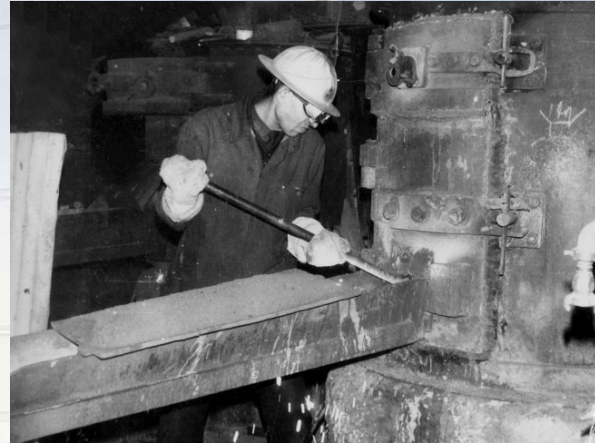

Group Company Founder Late Mr. Darshan Lal Sethi During Technology Transfer Training in Germany in the late 1960s.

We M/S Hind Gold Automotive Components HGAC Stringing Tools, Tower Erection and Equipment's manufacturing Company. The parent company was established in 1968 by Mr. Darshan Lal Sethi, an engineer who was trained with M/S Karl Schmidt GMBH, Neckarsulm, Germany and SIM Inter SA, Switzerland, where he got his experience in gravity/ chill casting of Aluminium and other ferrous and non-ferrous alloys. Activities of the company were manufacturing of automobile and other engineering components including Aerial rollers for SAE (India) now taken over by M/S KEC International Ltd. since 1970's. Now the group companies are managed by his heirs.

We are an ISO 9001:2015 & CE Compliance certified manufacturing firm having our own in-house casting, machining, testing and manufacturing facilities. We are catering to customers like M/S KEC International Ltd.(Domestic and International Division), M/S L & T, M/S Bajel Electricals, M/S Tata Projects, M/S Sterlite Power and Transmission Limited , Power Grid Corporation of India , M/S Transrail , M/S Unitech, M/S Kalpataru Power Transmission Limited and all leading players in stringing operations in India. Internationally, we have supplied for Projects at UAE, Senegal, Ivory Coast, Tanzania, Mozambique ,Ghana Projects, Bangladesh, Nepal, Sri Lanka , and many more countries. We are also catering to exporters and manufacturers who are in turn giving to other companies.

We have tool room and production facilities at two locations in Faridabad, near New Delhi, INDIA having state of art tool room and production machines like VMC's and CNC's and also conventional machines for making dies and for production of components. We have our own heat treatment plant to optimize the mechanical & physical properties of the steel and aluminium results in increase of tensile strength and wear resistance of the components as per the requirement of the product. We are having our in-house testing facility both Destructive & N.D.T. facilities such as Ultrasonic testing machine, universal testing machine, magnetic particle inspection, rubber tensile testing, hardness testers & special purpose testing machines as per product design. We are having designing facility, which works on Solid Works and Siemens NX platforms for part, product designing and their simulation.





HIND GOLD AUTOMOTIVE COMPONENTS

VISION

Our Mission is SAFETY FIRST. Safety of Workmen, Conductors, OPGW and to enhance excellence in Product design as per Application and attain Cost Competitiveness through continual improvements in Production methods, Design and Quality Systems.

Continuous improvement and Compliance with revised safety and other Guidelines by conductor manufactures and other quality guidelines like IEEE, etc. may result in change in product specifications for Longevity and Performance.

****PROJECTS EXECUTED**

HGAC has been solution provider and tool supplier to many important projects.

Sterlite Power Transmission Limited CTC GLOBAL ACCCULS Ganga Conductor Project, CTC GLOBAL ACCC Jhamkhabhaila Conductor Project and many more.

Apar industries limited CTC GLOBAL ACCC Hyderabad conduct project KPTL Bangladesh project for CTC Global ACCC Dhaka Conductor KEC international Limited Wagoona project And many more.



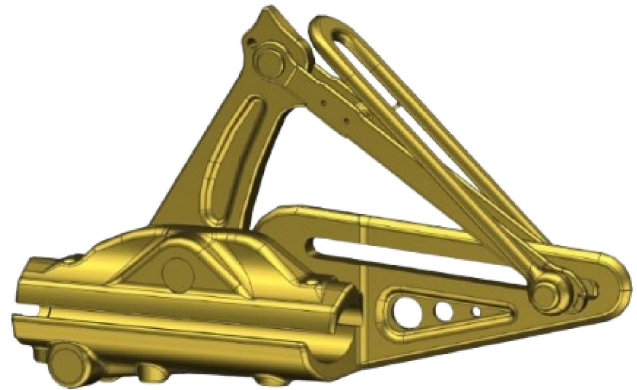
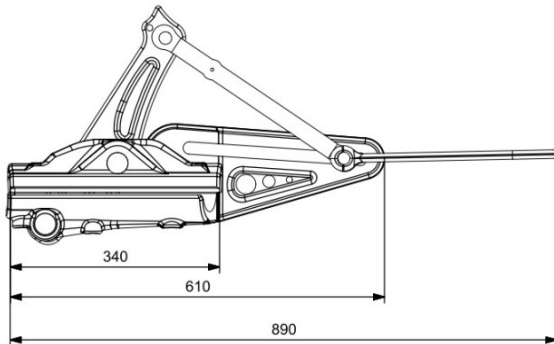

CONTENT

Automatic Clamp	1
Automatic Clamp Usage Procedures	10
Load Distribution	11
Bolted Come Along Clamp	12
Aerial Roller	13
Tandem Roller	17
Helicopter & Drone Application	18
Head Board	19
OPGW Tools	21
Pilot Wire Stand & Bobbin	22
Reel Elevator	23
Pull Cylinder	24
Snatch Block	25
Cable Roller	29
Turn Table	31
Joint Protector	32
Suspension Platform	33
Aluminium Ladder	34
Gin Pole	36
Swivel Joints	37
Crimping Die Sets	38
Pulling Grips(Socks)	39
Turn Buckle	40
Flat/Patta Clamp	40
Spacer Trolley	41
Running Earth	43
Discharge Rod Components	44
Pulling Eye	45
Nylon Sector	46
Testing Facility	47
Machine Facility	48

AUTOMATIC CLAMP 4158

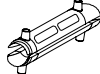

- 1. Total weight 26kg±5%
- 2. Maximum Working load 150kN
- 3. Breaking load 420kN

Interchangable Liner Range HG.01.4158				
Conductors Range	LR.A.58  Aluminium Liners Range	LR.B.58  Bronze Liners Range	LR.O.58  Liners for steel round wires	LR.S.58  Liners for steel square wires
41.5 - 43	LR.40.A 430	LR.40.B 430	Supplied on request with exact dia meter from 41 mm to 55 mm	Supplied on request as per application
43 - 44.5	LR.40.A 445	LR.40.B 445		
44.5 - 46	LR.46.A 460	LR.40.B 460		
46 - 47.5	LR.40.A 475	LR.40.B 475		
47.5 - 49	LR.46.A 490	LR.40.B 490		
49 - 50.5	LR.46.A 505	LR.40.B 505		
50.5 - 52	LR.40.A 520	LR.40.B 520		
52 - 53.5	LR.40.A 535	LR.40.B 535		
53.5 - 55	LR.40.A 550	LR.40.B 550		
55 - 56.5	LR.40.A 565	LR.40.B 565		
56.5 - 58	LR.40.A 580	LR.40.B 580		

* Maximum working load is subjective to Diameter and strength of the conductor.

Note: Drawing and specification can be changed without notice for enhancement of product performance. Normal industries tolerences apply

AUTOMATIC CLAMP 2346

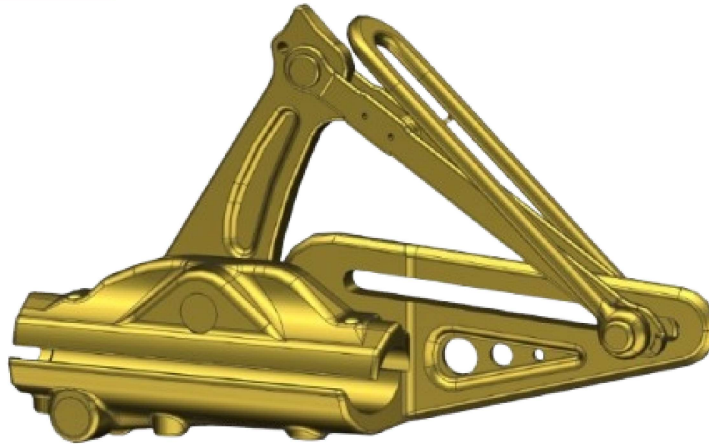

The self gripping clamps are made up of high tensile special alloy steel and are hot forged, heat treated, precision machined and zinc plated. They have a balanced ratio between weight and working load. A complete range of interchangeable liners suitable for ACSR, AAAC, HTLS, ACCC anti-twisting rope, earth wire, copper conductors are available for all types of gripping applications. For ACCC ACSS/TW we provide round jaws for maximum contact with the conductors. The liners are available in aluminium for aluminium/steel conductors and in bronze for copper conductors, pilot wire rope and steel earth wire from \varnothing 23 mm- 46 mm. Our range of self-gripping clamps promise high quality and comply with all international standards.

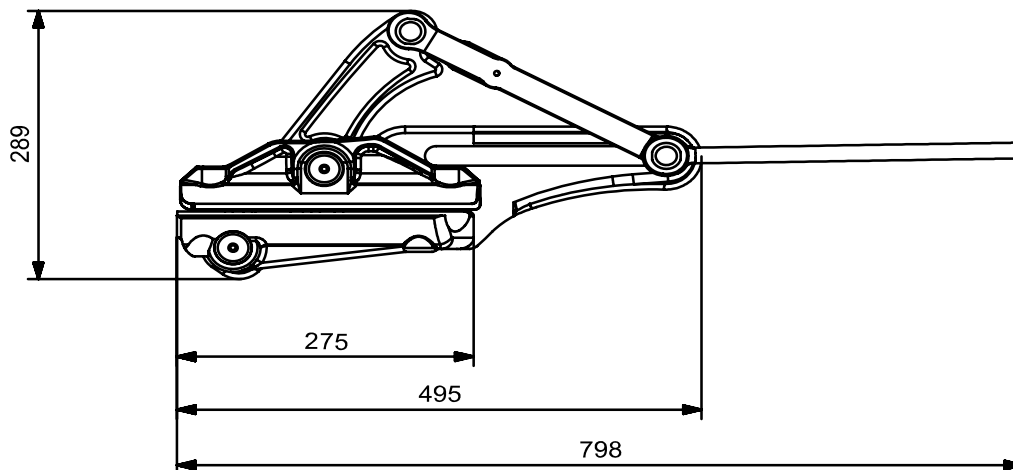

HG.01.2346

Maximum safety load	120 kN
Minimum breaking load	360 kN
Weight	18 kg

* Maximum working load is subjective to Diameter and strength of the conductor.

Note: Drawing and specification can be changed with notice for enhancement of product performance. Normal industries tolerances apply

AUTOMATIC CLAMP 2340

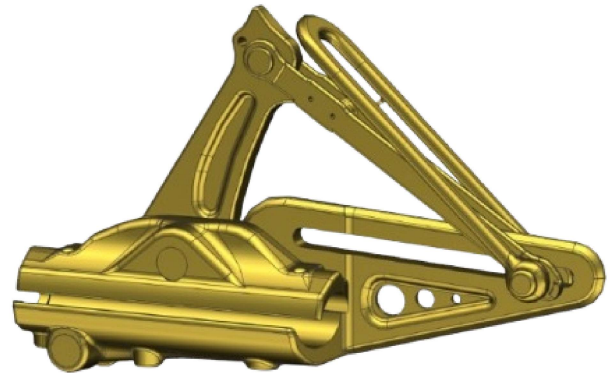
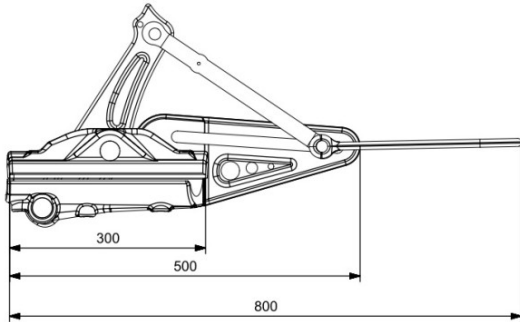

for speciality HTLS conductor like
ACCC conductor HVCR carbon core conductor

- | | |
|-------------------------|---------|
| 1. Total weight | 15kg±5% |
| 2. Maximum Working load | 100kN |
| 3. Breaking load | 320kN |

Interchangable Liner Range HG.01.2340				
Conductors Range	LR.A.40 Aluminium Liners Range	LR.A.40 Bronze Liners Range	LR.O.40 Liners for steel round wires	LR.S.40 Liners for steel square wires
23.5 - 25	LR.40.A 250	LR.40.B 250	Supplied on request with exact dia meter from 23mm to32mm	Supplied on request as per application
25 - 26.5	LR.40.A 265	LR.40.B 265		
26.5 - 28	LR.46.A 280	LR.40.B 280		
28 - 29.5	LR.40.A 295	LR.40.B 295		
29.5 - 31	LR.46.A 310	LR.40.B 310		
31 - 32.5	LR.46.A 325	LR.40.B 325		
32.5 - 34	LR.40.A 340	LR.40.B 340		
34 - 35.5	LR.40.A 355	LR.40.B 355		
35.5 - 37	LR.40.A 370	LR.40.B 370		
37 - 38.5	LR.40.A 385	LR.40.B 385		
38.5 - 40	LR.40.A 400	LR.40.B 400		





* Maximum working load is subjective to Diameter and strength of the conductor.

Note: Drawing and specification can be changed without notice for enhancement of product performance. Normal industries tolerences apply

INTERCHANGEABLE Liner for Clamps

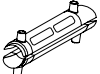

The Liners are available in aluminium and in bronze for Aluminium, copper, steel antitwisting rope and steel earth wire conductors as per application.

Interchangable Liner Range HG.01.2346				
Conductors Range	LR.A.46  Aluminium Liners Range	LR.B.46  Bronze Liners Range	LR.O.46  Liners for steel round wires	LR.S.46  Liners for steel square wires
23.5 - 25	LR.46.A 250	LR.46.B 250	Supplied on request with exact diameter from 23 mm to 46 mm.	Supplied on request as per application
25 - 26.5	LR.46.A 265	LR.46.B 265		
26.5 - 28	LR.46.A 280	LR.46.B 280		
28 - 29.5	LR.46.A 295	LR.46.B 295		
29.5 - 31	LR.46.A 310	LR.46.B 310		
31 - 32.5	LR.46.A 325	LR.46.B 325		
32.5 - 34	LR.46.A 340	LR.46.B 340		
34 - 35.5	LR.46.A 355	LR.46.B 355		
35.5 - 37	LR.46.A 370	LR.46.B 370		
37 - 38.5	LR.46.A 385	LR.46.B 385		
38.5 - 40	LR.46.A 400	LR.46.B 400		
40 - 41.5	LR.46.A 415	LR.46.B 415		
41.5 - 43	LR.46.A 430	LR.46.B 430		
43 - 44.5	LR.46.A 445	LR.46.B 445		
44.5 - 46	LR.46.A 460	LR.46.B 460		

* Maximum working load is subjective to Diameter and strength of the conductor.

Note: Drawing and specification can be changed with notice for enhancement of product performance. Normal industries tolerences apply

AUTOMATIC CLAMP 1041

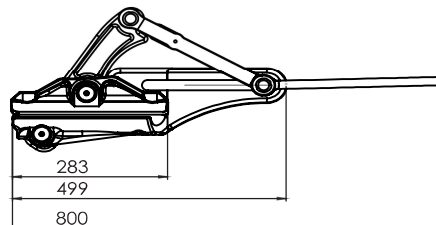
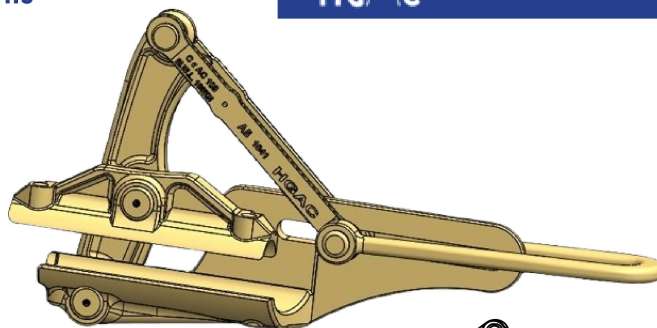





HG.01.1041

Maximum safety load 120 kN

Minimum breaking load 320 kN

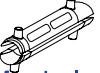
Weight 17.60 kg

Interchangeable Liner Range HG.01.1041				
Conductors Range	LR.A.41  Aluminium Liners Range	LR.B.41  Bronze Liners Range	LR.O.41  Liners for steel round wires	LR.S.41  Liners for steel square wires
10 - 11.5	LR.41.A 115	LR.41.B 115	Liner profile Saw tooth, Round, Oval, V Shaped or combination as per application	Liner profile Saw tooth, Round, Oval, V Shaped or combination as per application
11.5 - 13	LR.41.A 130	LR.41.B 130		
13 - 14.5	LR.41.A 145	LR.41.B 145		
14.5 - 16	LR.41.A 160	LR.41.B 160		
16 - 17.5	LR.41.A 175	LR.41.B 175		
17.5 - 19	LR.41.A 190	LR.41.B 190		
19 - 20.5	LR.41.A 205	LR.41.B 205		
20.5 - 22	LR.41.A 220	LR.41.B 220		
22 - 23.5	LR.41.A 235	LR.41.B 235		
23.5 - 25	LR.41.A 250	LR.41.B 250		
25 - 26.5	LR.41.A 265	LR.41.B 265		
26.5 - 28	LR.41.A 280	LR.41.B 280		
28 - 29.5	LR.41.A 295	LR.41.B 295		
29.5 - 31	LR.41.A 310	LR.41.B 310		
31 - 32.5	LR.41.A 325	LR.41.B 325		
32.5 - 34	LR.41.A 340	LR.41.B 340		
34 - 35.5	LR.41.A 355	LR.41.B 355		
35.5 - 37	LR.41.A 370	LR.41.B 370		
37 - 38.5	LR.41.A 385	LR.41.B 385		
38.5 - 40	LR.41.A 400	LR.41.B 400		
40 - 41.5	LR.41.A 415	LR.41.B 415		

* Maximum working load is subjective to Diameter and strength of the conductor.

Note: Drawing and specification can be changed without notice for enhancement of product performance. Normal industries tolerences apply

AUTOMATIC CLAMP 0836

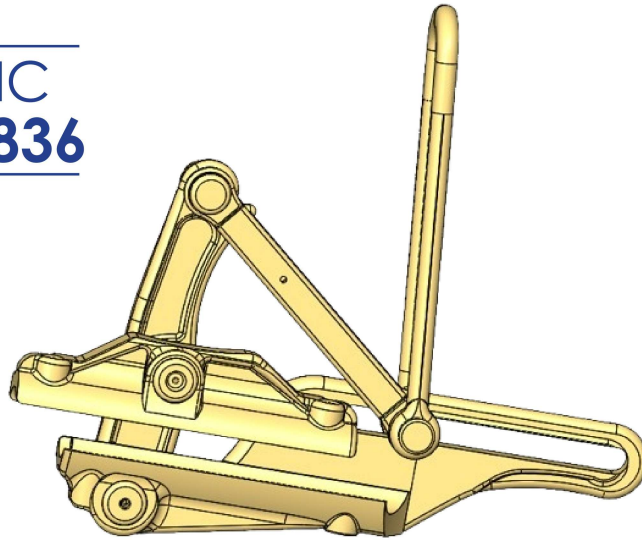

HG.01.0836

Safe Working load 50 kN
 Maximum Working load 75 kN
 Minimum breaking load 300 kN
 Weight 14 kg

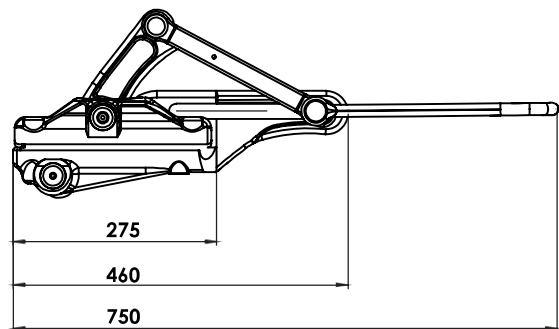

Interchangeable Liner Range HG.01.0836		
Conductors Range	LR.A.36	LR.B.36
	Aluminium Liners Range	Bronze Liners Range
21 - 22.5	LR.36.A 225	LR.36.B 225
22.5 - 24	LR.36.A 240	LR.36.B 240
24 - 25.5	LR.36.A 255	LR.36.B 255
25.5 - 27	LR.36.A 270	LR.36.B 270
27 - 28.5	LR.36.A 285	LR.36.B 285
28.5 - 30	LR.36.A 300	LR.36.B 300
30 - 31.5	LR.36.A 315	LR.36.B 315
31.5 - 33	LR.36.A 330	LR.36.B 330
33 - 34.5	LR.36.A 345	LR.36.B 345
34.5 - 36	LR.36.A 360	LR.36.B 360

* Maximum working load is subjective to Diameter and strength of the conductor.

Note: Drawing and specification can be changed without notice for enhancement of product performance. Normal industries tolerances apply

AUTOMATIC CLAMP 0832

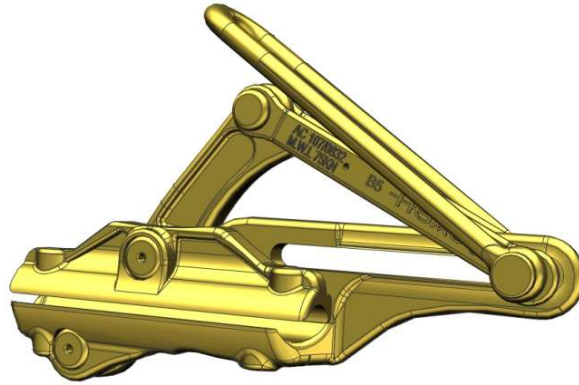

HG.01.0832

Safe Working load 50 kN
 Maximum Working load 75 kN
 Minimum breaking load 300 kN
 Total Weight 14 kg

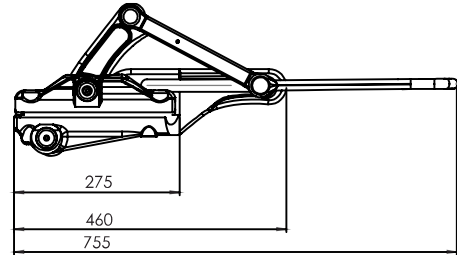

Interchangeable Liner Range HG.01.0832				
Conductors Range	LR.A.32 Aluminium Liners Range	LR.B.32 Bronze Liners Range	LR.O.32 Liners for steel round wires	LR.S.32 Liners for steel square wires
08 - 9.5	LR.32.A 95	LR.32.B 95	Supplied on request with exact diameter from 8 mm to 33 mm	Supplied on request with exact diameter from 8 mm to 33 mm
9.5 - 11	LR.32.A 110	LR.32.B 110		
11 - 12.5	LR.32.A 125	LR.32.B 125		
12.5 - 14	LR.32.A 140	LR.32.B 140		
14 - 15.5	LR.32.A 155	LR.32.B 155		
15.5 - 17	LR.32.A 170	LR.32.B 170		
17 - 18.5	LR.32.A 185	LR.32.B 185		
21 - 22.5	LR.32.A 225	LR.32.B 225		
22.5 - 24	LR.32.A 240	LR.32.B 240		
24 - 25.5	LR.32.A 255	LR.32.B 255		
25.5 - 27	LR.32.A 270	LR.32.B 270		
27 - 28.5	LR.32.A 285	LR.32.B 285		
28.5 - 30	LR.32.A 300	LR.32.B 300		
30 - 31.5	LR.32.A 315	LR.32.B 315		
31.5 - 33	LR.32.A 330	LR.32.B 330		

* Maximum working load is subjective to Diameter and strength of the conductor.

Note: Drawing and specification can be changed without notice for enhancement of product performance. Normal industries tolerances apply

AUTOMATIC CLAMP 0718

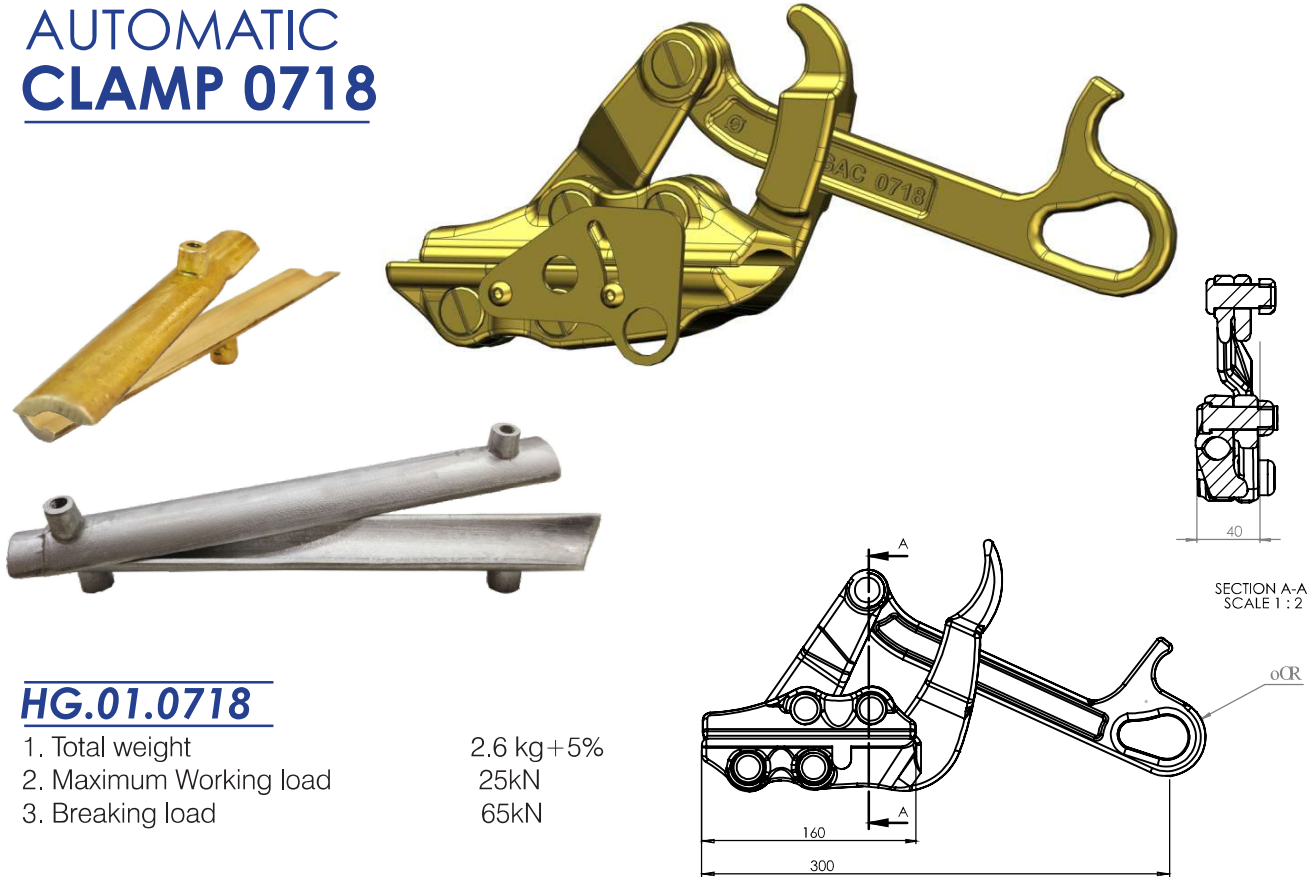

HG.01.0718

- | | |
|-------------------------|-----------|
| 1. Total weight | 2.6 kg+5% |
| 2. Maximum Working load | 25kN |
| 3. Breaking load | 65kN |

Interchangeable Liner Range HG.01.0718				
Conductors Range	LR.A.18 Aluminium Liners Range	LR.B.18 Bronze Liners Range	LR.O.18 Liners for steel round wires	LR.S.18 Liners for steel square wires
07 - 08.5	LR.18.A 85	LR.18.B 85	Liner profile Saw tooth, Round, Oval, V Shaped or combination as per application	Liner profile Saw tooth, Round, Oval, V Shaped or combination as per application
08.5 - 10	LR.18.A 100	LR.18.B 100		
10 - 11.5	LR.18.A 115	LR.18.B 115		
11.5 - 13	LR.18.A 130	LR.18.B 130		
13 - 14.5	LR.18.A 145	LR.18.B 145		
14.5 - 16	LR.18.A 160	LR.18.B 160		
16 - 17.5	LR.18.A 175	LR.18.B 175		
16.5 - 18	LR.18.A 190	LR.18.B 190		

* Maximum working load is subjective to Diameter and strength of the conductor.

Note: Drawing and specification can be changed without notice for enhancement of product performance. Normal industries tolerences apply

AUTOMATIC CLAMP 0623

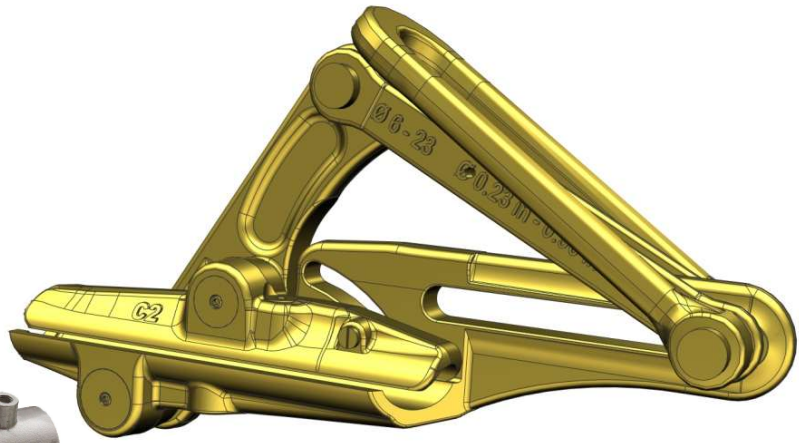

HG.01.0623

Safe Working load	25 kN
Maximum Working load	55 kN
Minimum breaking load	180 kN
Weight	7.5 kg+5%

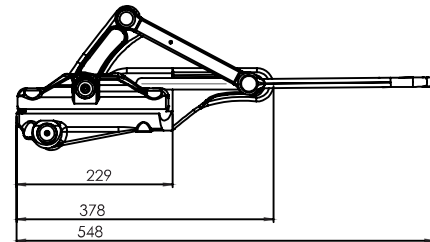

Interchangable Liner Range HG.01.0623				
Conductors Range	LR.A.23 Aluminium Liners Range	LR.B.23 Bronze Liners Range	LR.O.23 Liners for steel round wires	LR.S.23 Liners for steel square wires
6	LR.23.A 60	LR.23.B 60	Supplied on request with exact diameter from 6 mm to 23 mm.	Supplied on request with exact diameter from 6 mm to 23 mm.
6.5 - 8	LR.23.A 80	LR.23.B 80		
8 - 9.5	LR.23.A 95	LR.23.B 95		
9.5 - 11	LR.23.A 110	LR.23.B 110		
11 - 12.5	LR.23.A 125	LR.23.B 125		
12.5 - 14	LR.23.A 140	LR.23.B 140		
14 - 15.5	LR.23.A 165	LR.23.B 165		
15.5 - 17	LR.23.A 170	LR.23.B 170		
17 - 18.5	LR.23.A 185	LR.23.B 185		
18.5 - 20	LR.23.A 200	LR.23.B 200		
20 - 21.5	LR.23.A 215	LR.23.B 215		
21.5 - 23	LR.23.A 230	LR.23.B 230		

* Maximum working load is subjective to Diameter and strength of the conductor.

Note: Drawing and specification can be changed without notice for enhancement of product performance. Normal industries tolerences apply

AUTOMATIC CLAMP USAGE PROCEDURES

Dead-Ending

1. Set up the ratchet hoist and automatic clamp as shown here.
2. Ratchet the hoist until the cable is lined up with the dead-end fixture.
3. After the tension is approximately where it will need to be after termination, ratchet the hoist a couple more times to accommodate for tension loss after hoist removal. Consult conductor specifications to ensure the maximum conductor tension is not exceeded.
4. When finished, break the tension using the hoist handle, then use either the handle or drum knob to continue releasing the tension.

Sagging

1. Set up ratchet hoist, automatic clamp and dynamometer as shown here.
2. Ratchet the hoist until the dynamometer displays the desired tension. Consult conductor specifications or company procedures to determine the appropriate tension.
3. When finished, break the tension using the hoist handle, then use either the handle or drum knob to continue releasing the tension.

Splicing

1. Set up ratchet hoist and automatic clamps as shown here.
2. Connect the Web Strap Ratchet Hoist to each clamp, and ratchet to the desired tension to make the splice. The conductor can now be spliced according to standard work procedures and material guidelines.
3. When finished with the splice, break the tension using the hoist handle, then use either the handle or drum knob to continue releasing the tension.

LOAD DISTRIBUTION

For applications where the maximum load exceeds the safe load of an individual automatic clamps, or the cable is at risk of deformation, it is recommended to use two automatic clamps in tandem. Using two clamps in tandem divides the weight load between both the clamps, allowing for an effective work load increase of 1.5 times the safe load of each individual clamps.

For example: Two Automatic Clamp HG 0832, each with a maximum safe load of 19,980 lbs. (9,990 kg) individually, have a combined working safe load of 29,970 lbs. (14,985 kg).

In some transmission applications there is a risk of cable deformation under high tensions. To avoid this risk, using two clamps in tandem is recommended if:

- **ACSR or AAAC conductors** – the load is expected to exceed the lesser of 12,500 lbs. (5,670 kg) or 40% of the conductor tensile strength.
- **ACSS conductors**—the load is expected to exceed the lesser of 10,000 lbs. (4,536 kg) or 40% of the conductor tensile strength.



1. Place each automatic clamp on the same conductor, approximately five feet apart.
2. Connect a pulley block (levelling block) to the eye or U-Bend of each clamp. This will maintain equal distribution of the weight load between both clamps.
3. Connect an anchored chain hoist of appropriate capacity to the block as shown in the image above.
4. Ratchet the chain hoist to the desired tension, as shown in the image below.



Material Used : Two automatic clamps, ratchet hoist, dynamometer ,chain hoist & pulley block.

Disclaimer: This is not intended to be a definitive instructional manual for completing the applications. Always consult company procedures and conductor guidelines before attempting any application.

BOLTED COME-ALONG CLAMPS

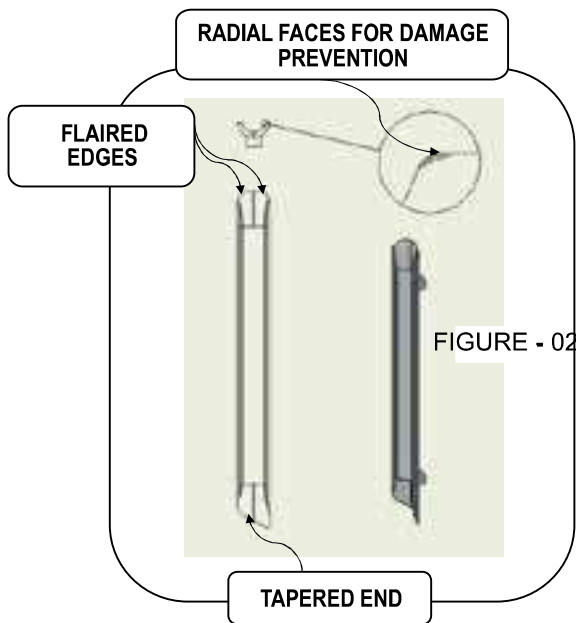
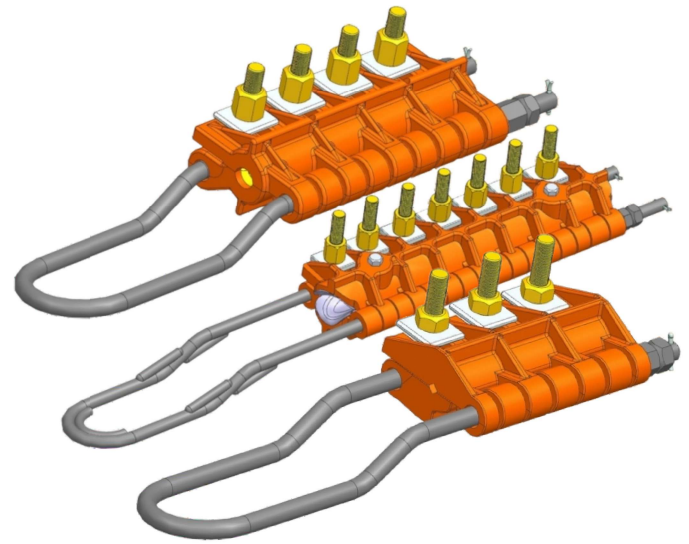
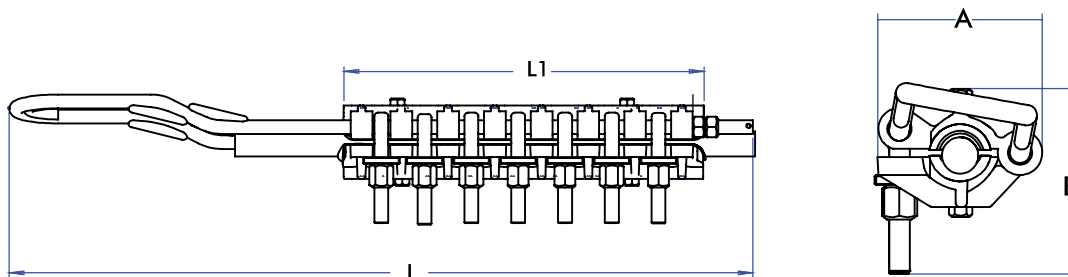

FIGURE - 02



The bolted come-along clamps are fit for pulling and anchoring overhead conductor, earthwire and steel wire ropes. The clamps are assembled by various cast and forged alloy steel parts. The grooves are fitted with gravity die casted aluminium alloy liner which are interchangeable according to the actual diameter of the conductor. A 2-3 mm side radius on liners is given to allow conductor expansion while tightening to avoid damage of conductor.



Model No.	Eye Bolt	Dimensions A X B X L (mm)	L1	For steel / earth wire rope upto Diameter*(mm)	For Conductor upto Diameter*(mm)	Working load (kN)	Breaking Load (kN)	Weight (kg)
HG.02.03	03	175X117X510	205	8-12	-	23	46	8.5
HG.02.04	04	125X117X635	315	10 -14	-	27	54	12
HG.02.07	07	420X117X790	420	-	23-33	60	120	16
HG.02.09	09	530X125X860	531	-	35-41	60	120	23

Note: Drawing and specification can be changed without notice for enhancement of product performance. Normal industries tolerances apply

AERIAL ROLLERS

Single Sheaves Aerial Rollers

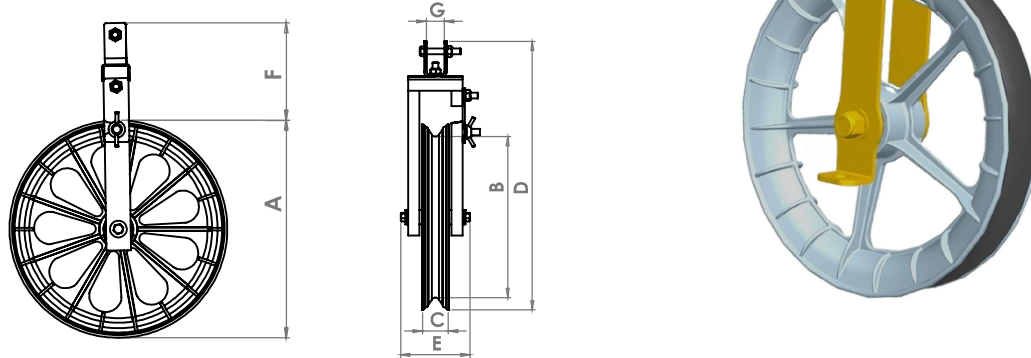

The Single sheave aerial roller is a gravity die cast aluminium alloy sheave, which is mounted on sealed ball bearing and groove lines with the neoprene / natural rubber compound flap for conductor protection. It is mounted on a fixed steel frame with standard plate attachment. It is fit for stringing overhead conductors.

Model No.	Dimensions(mm)							Working load (kN)	Breaking Load (kN)	Weight (kg)
	A	B	C	D	E	F	G			
HG.S.1.300	300							23	60	6
HG.S.1.400	400	339						25	60	9
HG.S.1.450	450	350						30	60	11
HG.S.1.540	540	470						33	99	27
HG.S.1.550	550	460						33	99	26
HG.S.1.560	560	470						33	99	30
HG.S.1.610	610	516						33	99	33
HG.S.1.600	600	516	C,D,E,F,G as per application					33	99	40
HG.S.1.660	660	550						33	99	30
HG.S.1.670	670	614						60	180	36
HG.S.1.715	715	621						33	99	37
HG.S.1.760	760	654						40	120	40
HG.S.1.800	800	696						60	180	39
HG.S.1.830	830	700						40	120	50
HG.S.1.915	915	800						60	180	60
HG.S.1.1130	1350	1020						60	180	75

- * Working loads may differ as per country or utility safety factors.
- * Customized high safety factor product can be made. As per IEEE 2017/ Conductor manufactures paying out guideline and sheave designed for adverse climate condition can also be supplied
- * Safety factor will also depend upon the hardware fitting.
- * Sheaves can be PU coated/ Nylontron sector/ Aluminium sector/ cast iron sector/ forged steel sector as per project/ application requirement
- * Upto the lip Rubberized sheave can also be supplied.

Attachment Type :

- Fix clevis
- Turn-able clevis
- Turn-able hook

On Request :

- Swivelling hook attachment.
- Interchangeable Aluminium/ Nylon lining sectors for bottom groove.
- Protective case for transport and stocking.
- Special frame like stand mounted sheave.

Note: Drawing and specification can be changed without notice for enhancement of product performance. Normal industries tolerances apply

THREE SHEAVE AERIAL ROLLERS

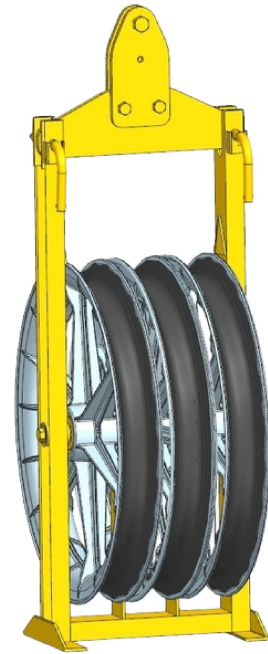
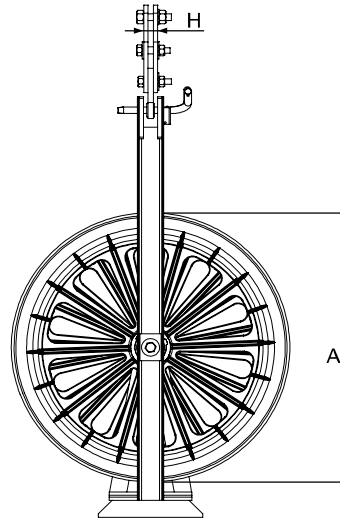
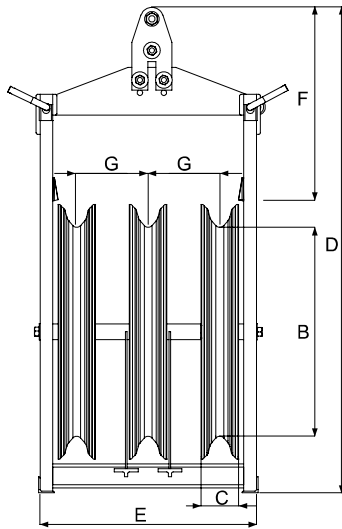

The three sheave aerial rollers are gravity die casted aluminium alloy sheaves, which are mounted on sealed ball bearing and groove lined with neoprene/natural rubber flaps for conductor protection. They are mounted on fixed steel frames with standard plate attachment.

Model No.	Dimensions(mm)								Working load (kN)	Breaking Load (kN)	Weight (kg)
	A	B	C	D	E	F	G	H			
HG.S.3.612	612	512	68						60	180	112
HG.S.3.660	660	573	77						70	180	112
HG.S.3.700	700	610	68						70	180	122
HG.S.3.760	760	650	95						70	180	122
HG.S.3.775	775	650	82.5	D,E,F,G,H as per application					70	180	122
HG.S.3.800	800	657	98						70	180	135
HG.S.3.820	820	710	90					70	180	155	
HG.S.3.915	915	800	95					70	180	165	
HG.S.3.1110	1110	1000	100					70	180	198	
HG.S.3.1350	1350	1200	130					70	180	220	

* Working loads may differ as per country or utility safety factors.

* Customized high safety factor product can be made. As per IEEE 2017/ Conductor manufactures paying out guideline and sheave designed for adverse climate condition can also be supplied

* Safety factor will also depend upon the hardware fitting.

* Sheaves can be PU coated/ Nylontron sector/ Aluminium sector/ cast iron sector/ forged steel sector as per project/ application requirement

* Upto the lip Rubberized sheave can also be supplied.

Attachment Type :

Fix clevis

Turn-able clevis

On Request :

Swivelling hook attachment.

Interchangeable Aluminium/ Nylon lining sectors for bottom groove.

Protective case for transport and stocking.

Note: Drawing and specification can be changed without notice for enhancement of product performance. Normal industries tolerances apply

FIVE SHEAVE AERIAL ROLLERS

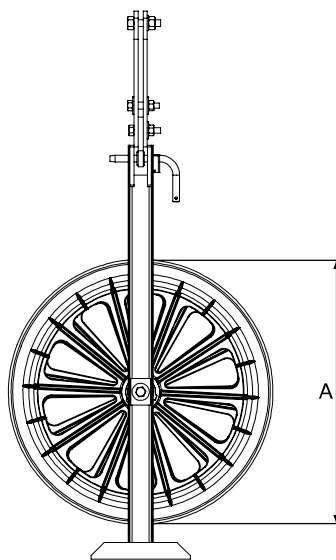
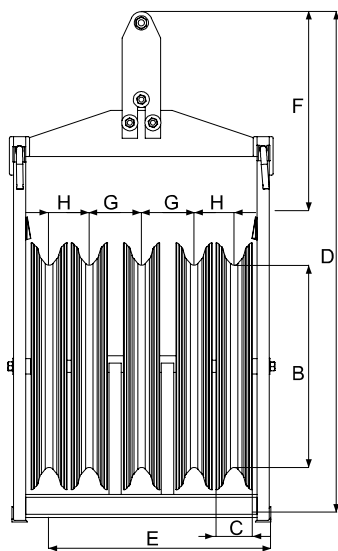

The five sheave aerial rollers are gravity die casted aluminium alloy sheaves, which are mounted on sheaves, which are mounted on sealed ball bearing and groove lined with neoprene/natural rubber flaps for conductor protection. They are mounted on fixed steel frames with standard plate attachment.

Model No.	Dimensions(mm)								Working load (kN)	Breaking Load (kN)	Weight (kg)
	A	B	C	D	E	F	G	H			
HG.S.5.612	612	512	68						60	180	155
HG.S.5.660	660	573	77						70	180	160
HG.S.5.710	710	610	68						70	180	165
HG.S.5.760	760	650	95						70	180	170
HG.S.5.775	775	650	82.5	D,E,F,G,H as per application					70	180	190
HG.S.5.800	800	657	98						70	180	225
HG.S.5.915	915	800	95						70	180	250
HG.S.5.1110	1110	1000	100						70	180	300
HG.S.3.1350	1350	1200	130						70	180	350

- * Working loads may differ as per country or utility safety factors.
- * Customized high safety factor product can be made. As per IEEE 2017/ Conductor manufactures paying out guideline and sheave designed for adverse climate condition can also be supplied
- * Safety factor will also depend upon the hardware fitting.
- * Sheaves can be PU coated/ Nylontron sector/ Aluminium sector/ cast iron sector/forged steel sector as per project/ application requirement
- * Upto the lip Rubberized sheave can also be supplied.

Attachment Type :

- Fix clevis
- Turn-able clevis

On Request :

- Swivelling hook attachment.
- Interchangeable Aluminium/ Nylon lining sectors for bottom groove.
- Protective case for transport and stocking.

Note: Drawing and specification can be changed without notice for enhancement of product performance. Normal industries tolerances apply

SEVEN SHEAVE AERIAL ROLLERS

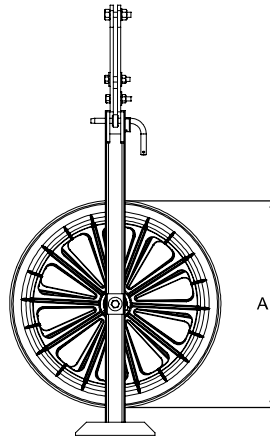
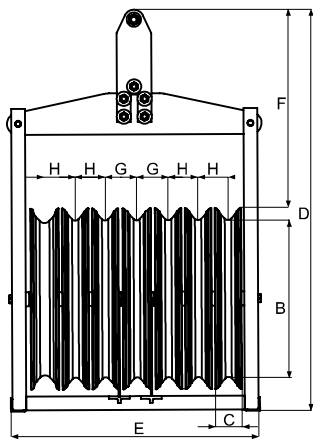

The seven sheaves aerial rollers are gravity die casted aluminium alloy sheaves, which are mounted on sealed ball bearing and groove lined with neoprene/natural rubber flaps for conductor protection. They are mounted on fixed steel frames with standard plate attachment.

They are fit for stringing 6 bundled conductors, having a central roller made of reinforced aluminium with 12 ribs, to increase the strength of the roller for carrying the load of the conductors and pilot wire.

Model No.	Dimensions(mm)								Working load (kN)	Breaking Load (kN)	Weight (kg)
	A	B	C	D	E	F	G	H			
HG.S.7.612	612	512	68						60	180	170
HG.S.7.660	660	573	77						70	180	170
HG.S.7.710	710	610	68						70	180	165
HG.S.7.760	760	650	95						70	180	170
HG.S.7.775	775	650	82.5	D,E,F,G,H as per application					70	180	190
HG.S.7.800	800	657	98						70	180	250
HG.S.7.915	915	800	95						70	180	260
HG.S.7.1110	1110	1000	100						70	180	330
HG.S.7.1350	1350	1200	130						70	180	400

- * Working loads may differ as per country or utility safety factors.
- * Customized high safety factor product can be made. As per IEEE 2017/ Conductor manufactures paying out guideline and sheave designed for adverse climate condition can also be supplied
- * Safety factor will also depend upon the hardware fitting.
- * Sheaves can be PU coated/ Nylonron sector/ Aluminium sector/ cast iron sector/forged steel sector as per project/ application requirement
- * Upto the lip Rubberized sheave can also be supplied.

Attachment Type :

- Fix clevis
- Turn-able clevis

On Request :

- Swivelling hook attachment.
- Interchangeable Aluminium/ Nylon lining sectors for bottom groove.

Note: Drawing and specification can be changed without notice for enhancement of product performance. Normal industries tolerences apply

TANDEM ROLLER

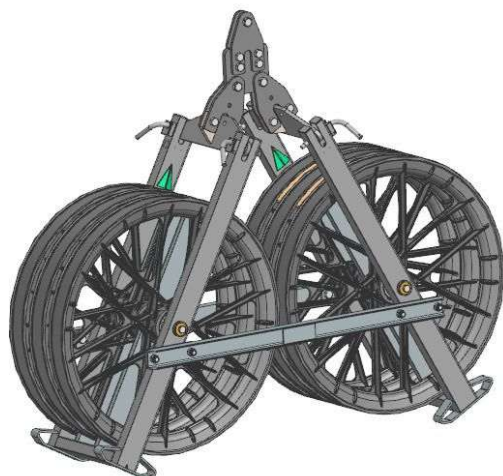

Special tandem rollers are built with a steel frame, connecting two standard sheaves. Tandem placement of sheaves increases the working load of the frame and bending arc of conductors, distributing the weight on both the sheaves.

Model No.	Refer Model	Sheave Dia (mm)A ϕ	Sheave Groove(mm)C	Working load (kN)	Breaking Load (kN)	Weight (kg)
HG.S.1.T.15	HG.S.1.15	150	49	12	36	16
HG.S. 1. T.30	HG.S.1.30	300	46	36	108	21
HG.S. 1. T.30.B	HG.S.1.30.B	300	62	36	108	22
HG.S. 1. T.45	HG.S.1.45	450	70	52	156	33
HG.S. 1. T.66	HG.S.1.66	660	77	60	180	98
HG.S. 1. T.70	HG.S.1.70	700	95	60	180	102
HG.S. 1. T.76	HG.S.1.76	760	95	60	180	102
HG.S. 1. T.80	HG.S.1.80	800	98	60	180	114
HG.S. 1. T.89	HG.S.1.89	890	98	60	180	120
HG.S. 1. T.91	HG.S.1.91	915	98	60	180	120

* Working loads may differ as per country or utility safety factors.

* Customized high safety factor product can be made. As per IEEE 2017/ Conductor manufactures paying out guideline and sheave designed for adverse climate condition can also be supplied

* Safety factor will also depend upon the hardware fitting.

* Sheaves can be PU coated/ Nylontron sector/ Aluminium sector/ cast iron sector/forged steel sector as per project/ application requirement

* Upto the lip Rubberized sheave can also be supplied.

Attachment Type :

Fix clevis

Turn-able clevis

On Request :

Swivelling hook attachment.

Interchangeable Aluminium/ Nylon lining sectors for bottom groove.

Protective case for transport and stocking.

Note: Drawing and specification can be changed without notice for enhancement of product performance. Normal industries tolerances apply

AERIAL ROLLERS FOR HELICOPTER AND DRONE APPLICATION

For Helicopter and aerial application special CAM arrangement makes it easy to insert the pulling rope automatically into the pulling rope sheave. Other customized arrangement like the ball bearing hinge mechanism can be provided.

AVAILABLE IN ALL DIAMETERS AND MOUNTING ARRANGEMENTS AS PER CUSTOMERS/ CONDUCTOR PAYING OUT REQUIREMENTS.

LICENSED BY
HIND GOLD AUTOMOTIVE COMPONENTS
IPO.PA.NO.2024110435865/2024

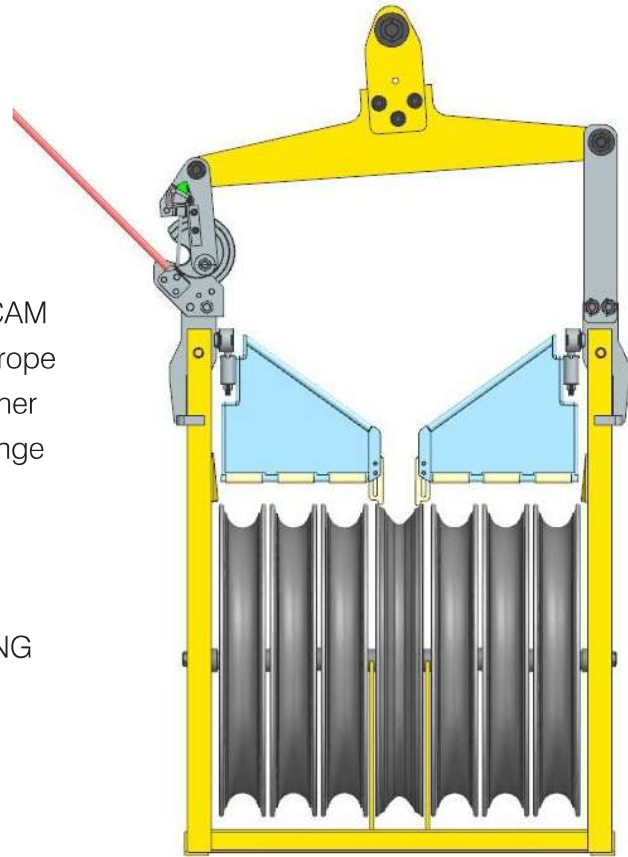

- * Working loads may differ as per country or utility safety factors.
- * Customized high safety factor product can be made. As per IEEE 2017/ Conductor manufactures paying out guideline and sheave designed for adverse climate condition can also be supplied
- * Safety factor will also depend upon the hardware fitting.
- * Sheaves can be PU coated/ Nylontron sector/ Aluminium sector/ cast iron sector/forged steel sector as per project/ application requirement
- * Upto the lip Rubberized sheave can also be supplied.

Note: Drawing and specification can be changed without notice for enhancement of product performance. Normal industries tolerences apply

HEAD BOARDS

Optical Ground-Wire(OPGW) Anti- Twisting Device



This device is specially designed to connect the pulling rope with an OPGW. It is composed of several jointed rods and two arched rods (to facilitate the passage on pulley) with counter weight in order to prevent torsion of OPGW.

Model No.	Dimensions (mm)			Working load (kN)	Breaking Load (kN)	Weight (kg)	OPGW DIA (MM)
	A (Length)	B	C				
HG.HB.OPGW.D17	3900			10	30	60	9-17
HG.HB.OPGW.D24	4300			10	30	63	17-24

*R = radius requires to be changed as per the roller dia.

NOTE : Please specify the dia. of OPGW, groove diameter and the width of pulley bolck to be used, while placing on order.

Headboard For Sheaves

The headboard are designed in such a way that they can self- adjust to a correct position while passing over aerial rollers, enabling the conductors to pass through the grooves of the sheaves. The hinged tail assembly, made up of forged links(UT tested), stabilizes the headboard against lateral lifting due to wind pressure. The load carrying members like balancing pulley, having roller bearing for high load bearing capacity, are made of heat treated alloy steel, which makes

2-3 Bundled Conductor Headboard

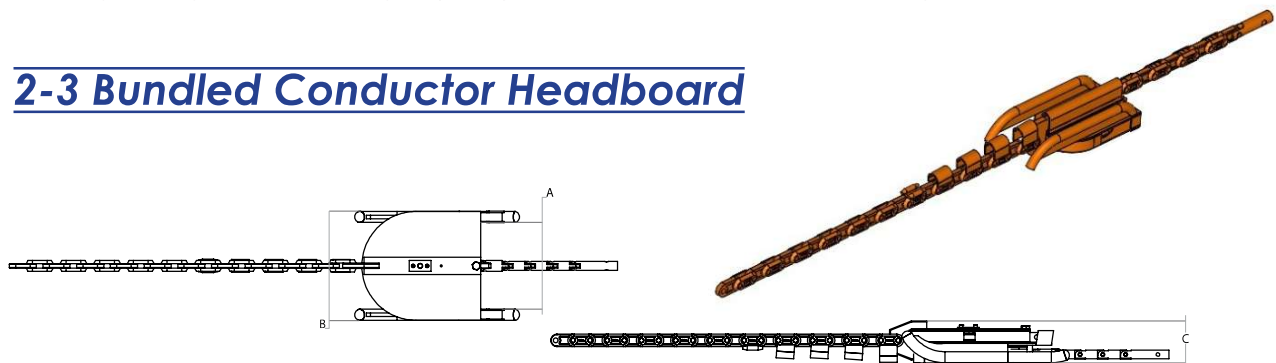

It is specially designed to connect the pulling with 2 or 3 bundled conductors

Model No.	Dimensions (mm)			Working load (kN)	Breaking Load (kN)	Weight (kg)
	A	B	C			
HG.HB.03	216	261	193	100	300	89

Note: Drawing and specification can be changed without notice for enhancement of product performance. Normal industries tolerences apply

4-5 BUNDLED CONDUCTOR HEADBOARDS

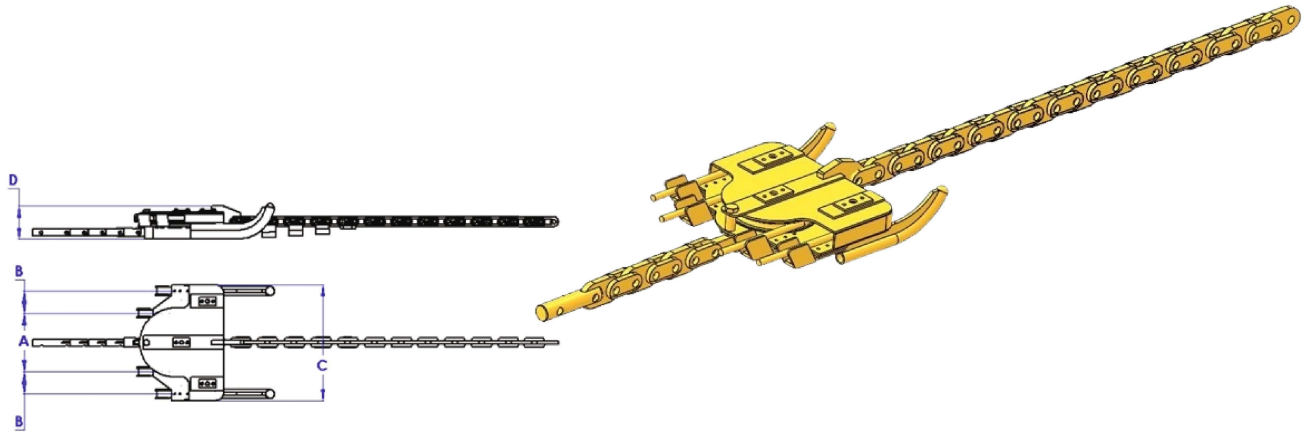

It is specially designed to connect the pulling rope with 4 or 5 bundled conductors.

Model No.	Dimensions (mm)				Working load (kN)	Breaking Load (kN)	Weight (kg)
	A	B	C	D			
HG.HB.05	340	130	675	194	93	279	118

6-7 BUNDLED CONDUCTOR HEADBOARDS

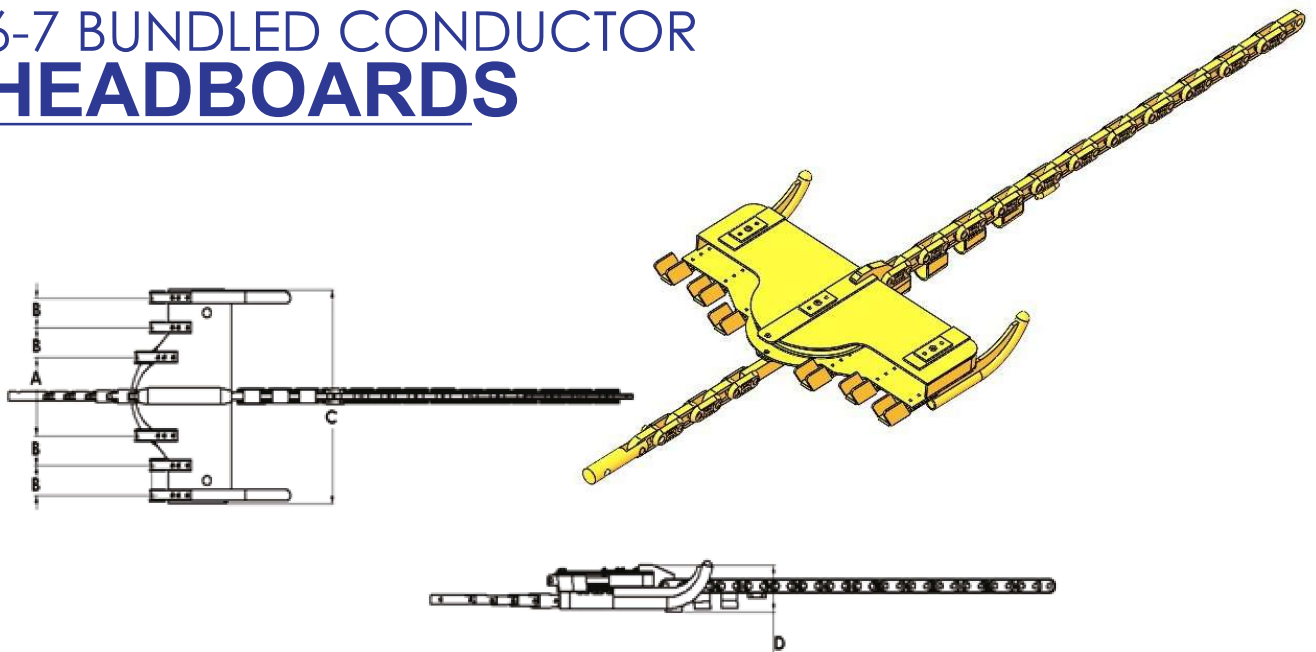

It is specially designed to connect the pulling rope with 6 or 7 bundled conductors.

Model No.	Dimensions (mm)				Working load (kN)	Breaking Load (kN)	Weight (kg)
	A	B	C	D			
HG.HB.07	340	130	930	200	150	450	156

Note: Drawing and specification can be changed without notice for enhancement of product performance. Normal industries tolerances apply

OPGW TOOLS OPTICAL GROUND WIRE



AERIAL ROLLERS FOR OPGW

Tools designed as per OPGW configuration covering IEEE 2017 Guidelines & OPGW manufacturers guidelines. These items are rubberized up to the lip & special groove radius is provided to protect OPGW fibers & outer aluminum layers.

AUTOMATIC CLAMPS FOR OPGW

Automatic clamps with Extra long Jaw, one PU (Polyurethane) sleeve for protection/cushioning to avoid fibre damage.



PILOT WIRE REEL STAND & BOBBIN

Pilot Wire Reel Stand

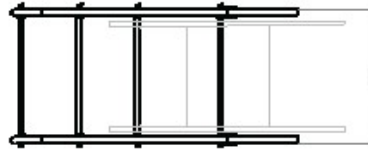
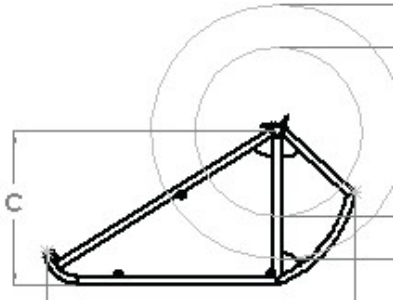
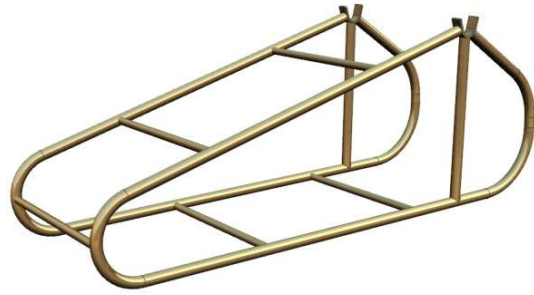

It is made of welded steel with a protective coating.

Options:

- Detachable frame
- Disc brakes

Model No.	Dimensions (mm)					Working load (kN)	Breaking Load (kN)	Weight (kg)
	A	B	C	D				
				Min.	Max.			
HG.RS	1980	950	980	700	1400	20	60	72

Pilot Wire Bobbin

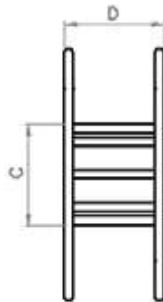
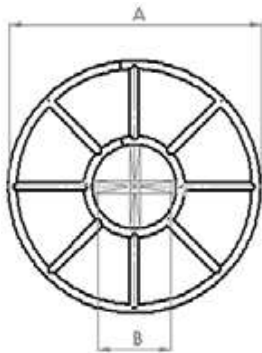

The reels are made of welded steel with a protective coating. Each reel is provided with two cross supports and connecting bolts .

Model No.	Dimensions (mm)				Weight (kg)
	A	B	C	D	
HG.WR.11	1100	420	570	550	60
HG.WR.14	1400	420	570	550	80

Note: Drawing and specification can be changed without notice for enhancement of product performance. Normal industries tolerences apply

REEL ELEVATOR



They are suitable for paying out conductor/earth wire/OPGW cables. They are made up of welded steel with a protective coating. Each reel elevator is provided with supports like fixed wedges for clamping the wooden/steel conductor drum and mechanical disk braking system for controlling the rotational speed of the drum while paying out the conductor. The frame is completely detachable, enabling easy transportation.

Optional devices:

- Additional disc brake (2 brakes in total)
- Hydraulic Jack could be provided in lieu of

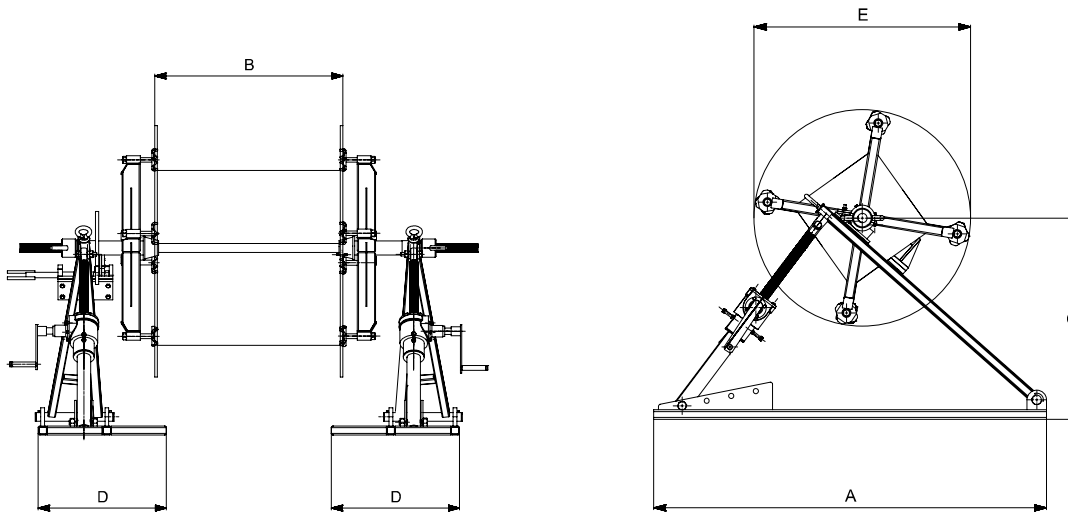

Model No.	Dimensions (mm)						Working load (kN)	Breaking Load (kN)	Weight (kg)
	A	B	C(min.)	C(max.)	D	E			
HG.RE.05T	1800	1186	677	1087	647	1194	49	147	340
HG.RE.07T	1800	1350	720	1180	716	1200	79	237	410
HG.RE.10T	2000	1029.2	725	1025	700	1100	98	294	483
HG.RE.15T	2000	1350	720	1180	716	2200	98	294	483

Note: Drawing and specification can be changed without notice for enhancement of product performance. Normal industries tolerences apply

PULL CYLINDER

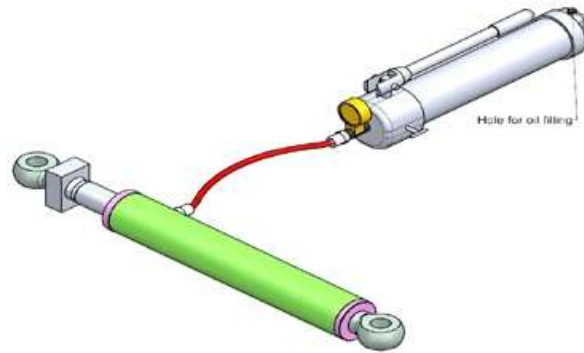

Single-acting with spring return, capacity max. 5 T – 51T

Pull cylinders are able to produce extremely high pulling forces and can be controlled precisely by the use of hand pumps or power packs in neutral position pull cylinders are fully extended. As soon as the cylinders are pressurized the forged links are drawn together. A built-in rum spring extends the piston again as soon as the pressure is released.

Shipbuilding, heavy-vessel construction, steel construction, civil engineering, Transmission line as well as general repair and maintenance applications.

Features:-

- Operating pressure max 700 bar.
- Single-acting with spring return.
- Can be operated in all positions.
- Cylinder body and piston are made from solid chromium-molybdenum steel and heat- treated. Cylinder also made from seamless burnished high tensile tubes.
- Hard-chromium plated piston with replaceable, heat-treated saddle.
- Stop ring can bear full capacity (pressure) and is fitted with dirt wiper.
- Forged, replaceable links.
- With carrying handle and piston protection cover.
- Oil port thread 3/8 NPT/customized.
- Incl. female coupler customized.
- Special features can be incorporated/ custom built as per application.

Model No.	Force ton/ (KN)	Stroke mm	Remarks
HG.PC-10/75	10 /100	75	The length of stroke, force & weight can be customised as per application.
HG.PC-10/300	10 /100	300	
HG.PC-20/300	20/200	300	
HG.PC-30/300	30/300	300	
HG.PC-51/300	51/5100	300	

Note: Drawing and specification can be changed without notice for enhancement of product performance. Normal industries tolerences apply

SNATCH BLOCKS *5 Ton*

Single Close/Open Type Hook

The service snatch block is made of a galvanized steel sheave mounted on double ball bearings. The sheave is mounted on a galvanized steel frame with an openable side and a standard eye hook attachment.



Model No.	Sheave diameter (in)	+ Bearing Size	Dimensions (mm)					Groove Radius *R	Working load (KN)	Breaking Load (kN)	Weight (kg)
			A	B	C	D	E				
HG.P.C.5T.SH	4.33	1x6305	110				29.5	12.25	50	200	5
				B,C,D as per application							
HG.P.O.5T.SH	6	2x6205	152				28.4	12.5	50	200	5.5

*R- Radius and angle can be customized as per rope /customer/application requirements
 +-can be provided with roller bearing/bronze bearing
 O -Sheave materials can be customized as per rope/customer/application requirements

Note: Drawing and specification can be changed without notice for enhancement of product performance. Normal industries tolerances apply

Meets or exceeds international standards ASME B30 26-2015
 Visit the info@hgac.co.in for more information

Single Close/Open Eye Type 5 Ton/ 8 Ton

The service snatch block is made of a galvanized steel sheave mounted on double ball bearings.

The sheave is mounted on a galvanized steel frame with an openable side and a standard eye hook attachment.

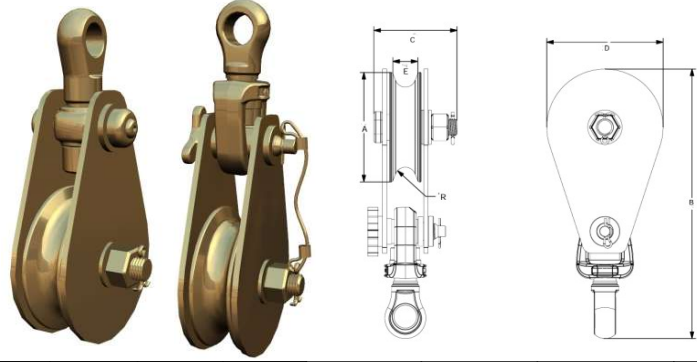

Model No.	Sheave diameter (in)	+ Bearing Size	Dimensions (mm)					Groove Radius *R	Working load (KN)	Breaking Load (kN)	Weight (kg)
			A	B	C	D	E				
HG.P.O.5T.SH	5	2x6305	127	313	90	135	29	12.25	50	200	5.7
HG.P.C.5T.SH	5	2x6305	127	276	95	135	29	12.25	50	200	5
HG.P.C.5T.LS	6	2x6205	152	340	96	160	23	11.25	50	150	7.3
HG.P.C.8T.SE	5	2x6305	127	287	98	135	29	12.25	80	320	6.5
HG.P.C.8T.SE	6	2x6305	152	298	95	155	26	12.25	80	320	7
HG.P.O.8T.SE	5	2x6305	127	295	97	135	29	12.25	80	320	6.5
HG.P.O.8T.SE	6	2x6305	152	295	97	155	26	12.25	80	320	7.5

Double Close/Open Eye Type 5 Ton/ 8 Ton

The service snatch block is made of a galvanized steel sheave mounted on double ball bearings.

The sheave is mounted on a galvanized steel frame with an openable side and a standard eye hook attachment.

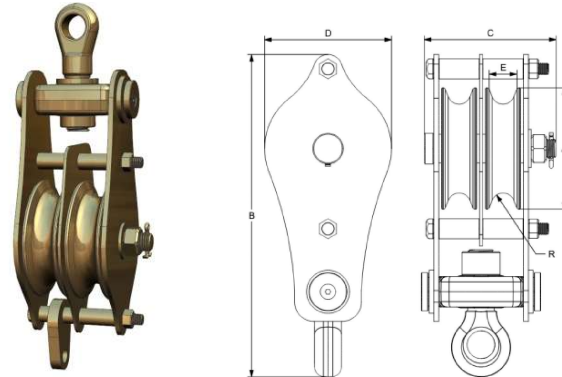

Model No.	Sheave diameter (in)	+ Bearing Size	Dimensions (mm)					Groove Radius *R	Working load (KN)	Breaking Load (kN)	Weight (kg)
			A	B	C	D	E				
HG.PD.C.5T.SE	4.5	1x6305	115				17.8	6.5	50	200	7.5
HG.PD.C.5T.SE	5	1x6305	127				18	8.5	50	200	7.6
HG.PD.C.5T.SE	5	1x6305	127	B,C,D as per application			18	12.5	50	200	9
HG.P.C.10T.SH	6	1x6305	150				17	8.5	80	320	10.5
HG.P.C.10T.SH	5	2x6305	127				29	12.25	80	320	10

*R- Radius and angle can be customized as per rope /customer/application requirements

+ -can be provided with roller bearing/bronze bearing

O -Sheave materials can be customized as per rope/customer/application requirements

Note: Drawing and specification can be changed without notice for enhancement of product performance. Normal industries tolerances apply

Double Close/Open Type Hook 5 Ton

The service snatch block is made of a galvanized steel sheave mounted on double ball bearings.
 The sheave is mounted on a galvanized steel frame with an openable side and a standard eye hook attachment.

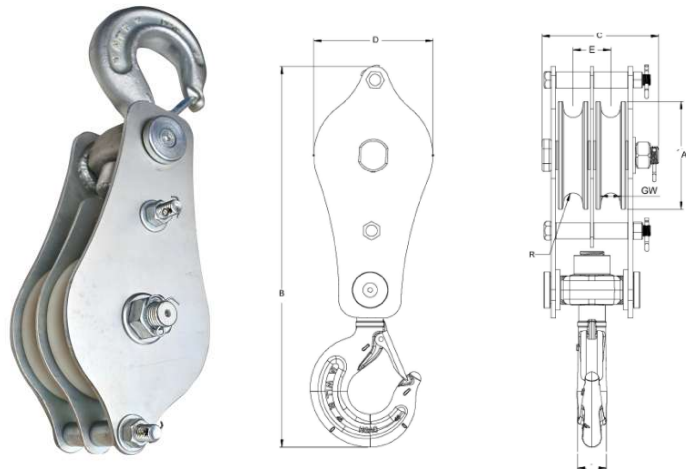

Model No.	Sheave diameter (in)	+ Bearing Size	Dimensions (mm)					Groove Radius *R	Working load (KN)	Breaking Load (kN)	Weight (kg)
			A	B	C	D	E				
HG.P.C.5T.DE	4.3	1x6305	110	344	72	140	17.8	6.5	50	200	5

Three Close/Open EYE/ Hook Type 5 Ton

The service snatch block is made of a galvanized steel sheave mounted on double ball bearings.
 The sheave is mounted on a galvanized steel frame with an openable side and a standard eye hook attachment.

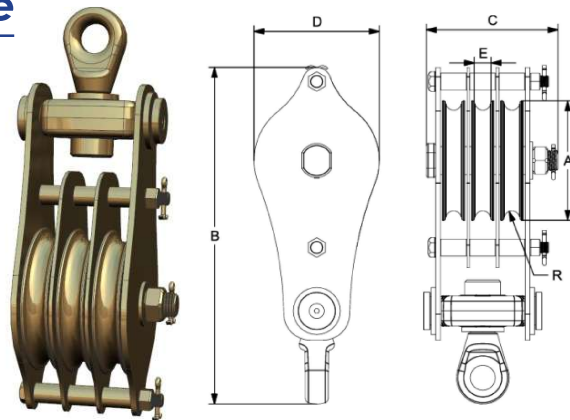

Model No.	Sheave diameter (in)	+ Bearing Size	Dimensions (mm)					Groove Radius *R	Working load (KN)	Breaking Load (kN)	Weight (kg)
			A	B	C	D	E				
HG.P.C.5T.TE	5	1x6305	127	B,C,D as per application			17.8	8.5	50	200	10.5
HG.P.C.5T.TE	5	1x6305	127				17.8	8.5	50	200	10.5

*R- Radius and angle can be customized as per rope /customer/application requirements
 +-can be provided with roller bearing/bronze bearing
 O -Sheave materials can be customized as per rope/customer/application requirements

Note: Drawing and specification can be changed without notice for enhancement of product performance. Normal industries tolerances apply

Meets or exceeds international standards ASME B30 26-2015
 Visit the info@h

Four Close EYE/ Hook Type 5 Ton/ 10 Ton

The service snatch block is made of a galvanized steel sheave mounted on double ball bearings. The sheave is mounted on a galvanized steel frame with an openable side and a standard eye hook attachment.

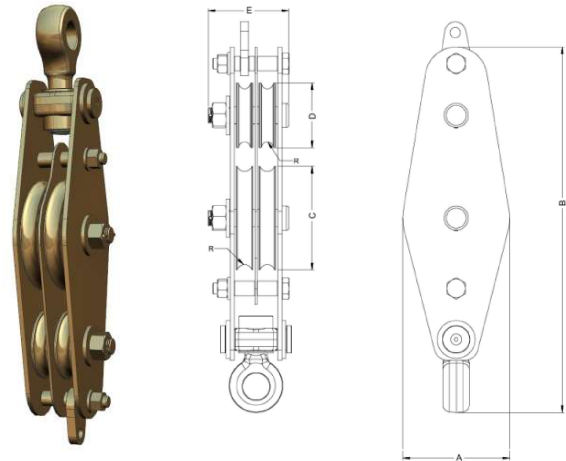

Model No.	Sheave diameter (in)	+ Bearing Size	Dimensions (mm)					Groove Radius *R	Working load (KN)	Breaking Load (kN)	Weight (kg)
			A	B	C	D	E				
HG.P.C.5T.SH	5/3.7	1x6305	147	194	127	94	121	8.5	50	200	13
HG.P.C.10T.SE	6	1x6305	155	530	150	94	117	8.5	80	320	10.5
HG.P.C.5T.FH	5/3.7	1x6305	147	577	127	94	107	8.5	50	200	14

Six Eye Type 10 Ton

The service snatch block is made of a galvanized steel sheave mounted on double ball bearings. The sheave is mounted on a galvanized steel frame with an openable side and a standard eye hook attachment.

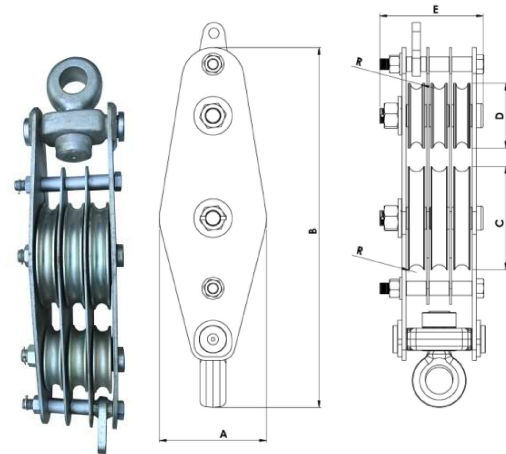

Model No.	Sheave diameter (in)	+ Bearing Size	Dimensions (mm)					Groove Radius *R	Working load (KN)	Breaking Load (kN)	Weight (kg)
			A	B	C	D	E				
HG.P.C.10Ton.SE	6	1x6305	155				150	8.5	100	400	19

NOTE: Application of eye attachment with D Shackle available for all snatch blocks mentioned above.



- *R- Radius and angle can be customized as per rope /customer/application requirements
- +can be provided with roller bearing/bronze bearing
- O -Sheave materials can be customized as per rope/customer/application requirements

Note: Drawing and specification can be changed without notice for enhancement of product performance. Normal industries tolerances apply

CABLE ROLLER

Cable Roller is gravity die cast aluminium alloy sheave made from high quality materials. Frame made of SS

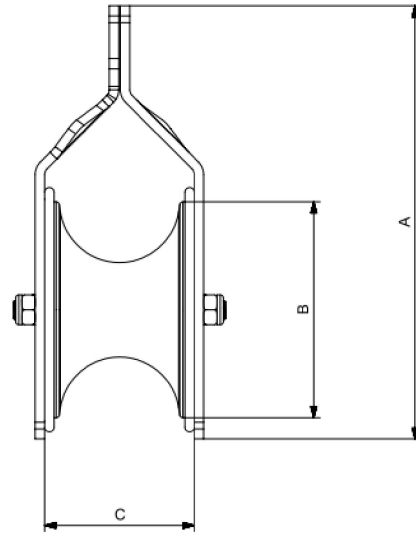

Model No.	Dimensions (mm)			WEIGHT (kg)
	A	B	C	
HGAC.C.R	275	137	95	2.2

Note: Drawing and specification can be changed without notice for enhancement of product performance. Normal industries tolerences apply

EQUILIZER PULLEY

The service equalizer pulley is made of a galvanized steel sheave mounted on double ball bearings. The sheave is mounted on a galvanized steel frame with an openable side and a standard eye hook attachment.

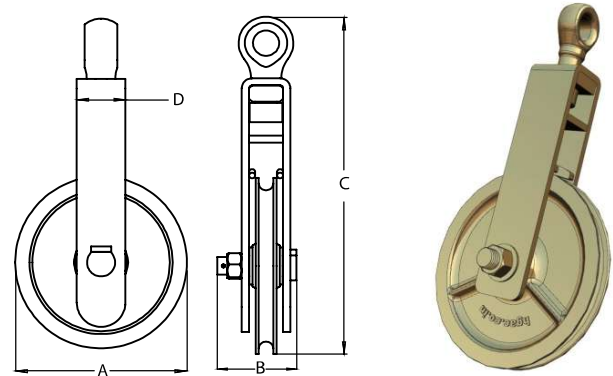

Model No.	Dimensions (mm)				Working load (kN)	Breaking Load (kN)	Weight (kg)
	A	B	C	D			
HG.P.O.5T	250	130	576	32	49	98	12
HG.P.O.10T	300	130	582	85	98	196	22
HG.P.O.15T	300	130	590	85	147	294	22

HANGING PULLEY

The cradle block is specially designed for replacing the existing ground wire (GW) with optical grounding wire (OPGW) cables. It is made of two galvanized steel half-frames linked by a ring with a swivel plate. Each half frame consists of one grooved aluminium wheel mounted on ball bearings, three nylon plates to protect the OPGW cables, and easy to open sides.

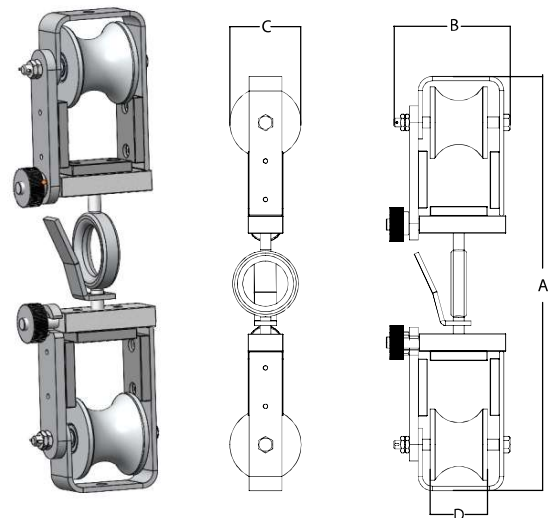

Model No.	Dimensions (mm)			Working load (kN)	Breaking Load (kN)	Weight (kg)
	A	B	C			
HG.HP.B.AL	446	130	75	02	15.8	4.4
HG.HP.AL	378	113	58	02	10	2.38

Note: Drawing and specification can be changed without notice for enhancement of product performance. Normal industries tolerances apply

TURN TABLE

Turn Tables are made up of welded steel with a protective coating. They are suitable for placing the conductor drum in an upright position for a smooth release of the conductor, while paying out. Turn Table braking arrangement is provided.

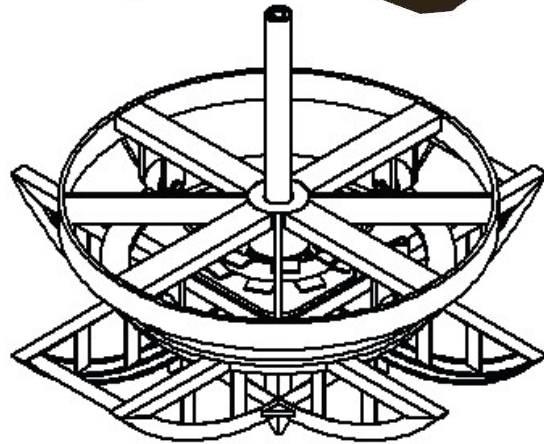
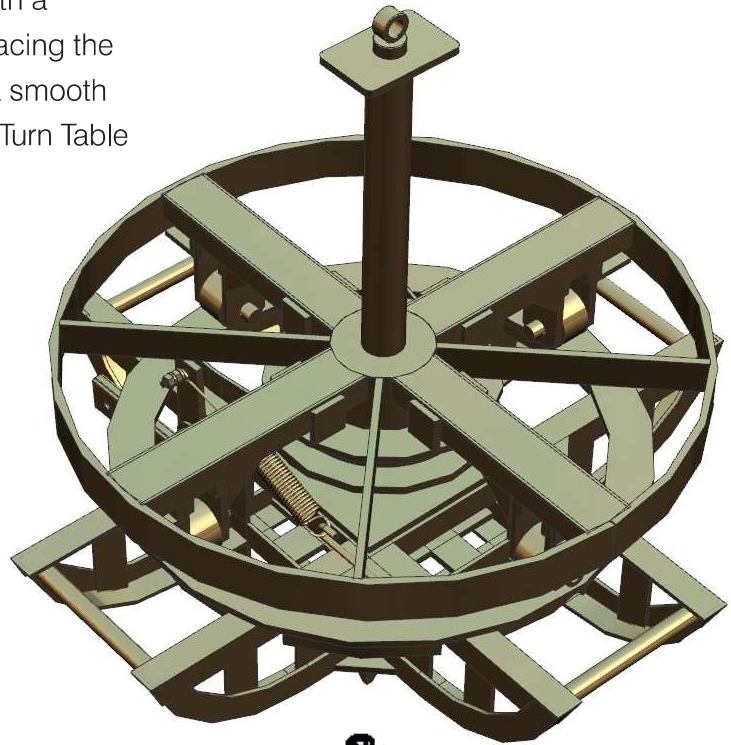
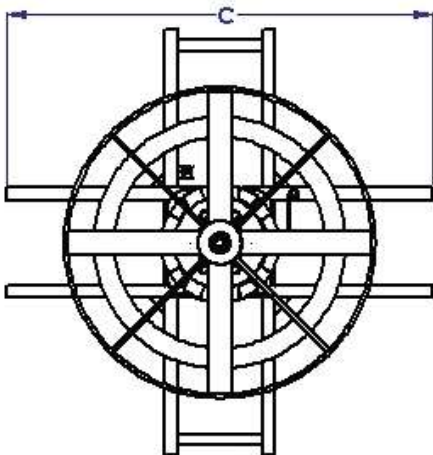
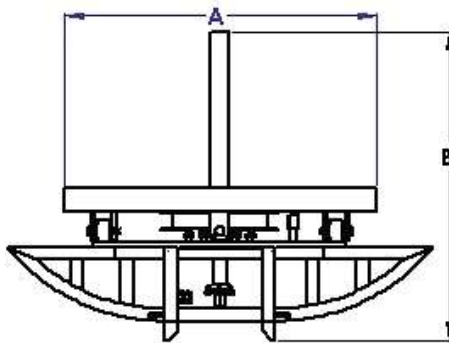

Model No.	Dimensions (mm)			Working load (kN)	Breaking Load (kN)	Weight (kg)
	A	B	C			
HG.TT.05T	990	982	193	49	147	190
HG.TT.07T	1011	261	193	74	222	260
HG.TT.10T	1046	261	193	98	294	410

Note: Drawing and specification can be changed without notice for enhancement of product performance. Normal industries tolerances apply

COVER JOINTS/ JOINT PROTECTOR

They are specifically designed to protect the mid span joint made at the "Tensioner Station", during conductor stringing operations.

The cover joints consist of two shells made of special seamless pipe with shaped ends to house rubber hoses, as per the conductor requirement, centre free space as per conductor hexagonal crimp, and mid span joint lengths (after compression).

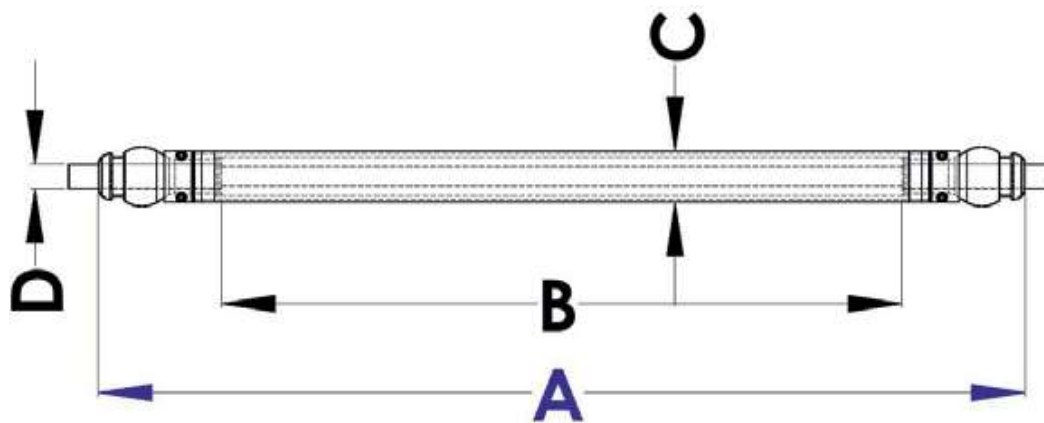

Model No.	A (mm)	B (mm)	C (mm)	D (mm)	Working load (kN)	Breaking Load (kN)	Weight (kg)
HG.JP.Z	1095	805	61	28	7	20	7
HG.JP.M	1204	864	72	32	7	20	12
HG.JP.B/L	1321	974	84	39	7	20	18

*Special customized Joint protector as per mid span joint also provided.

Wherein,

1. L = joint length after compression.
2. D = conductor Diameter.
3. Hex= the hexagon dimension of mid span joint after compression.

Note: Drawing and specification can be changed without notice for enhancement of product performance. Normal industries tolerances apply

SUSPENSION PLATFORM

Suspension platforms are made of light aluminium alloy in triangular and trapezoidal section, welded by TIG system. All the platforms are provided with the provision for anti-fall barrier.

NOTE: Special suspension platforms can be built with extra length and strength upon request.

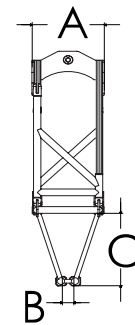
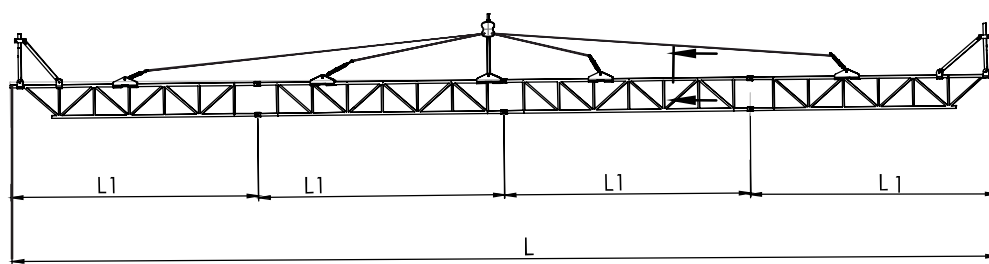
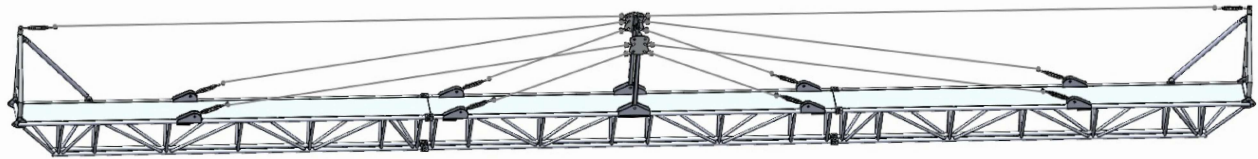

Model No.	Total length(L)	Lateral Section length(L1)	Working load(kg)	A (mm)	B (mm)	C (mm)	Weight (kg)
HG.SP.05M	5	----	300	320	80	350	60
HG.SP.07M	7	4 + 3	300	320	80	350	65
HG.SP.10M	10	5 + 5	300	350	80	450	105
HG.SP.12M	12	4 + 4 + 4	600	350	80	450	120
HG.SP.16M	16	4 + 4 + 4 + 4	600	350	80	450	155
HG.SP.18M	18	6 + 6 + 6	600	350	80	450	250
HG.SP.24M	24	6 + 6 + 6 + 6	600	450	85	550	300
HG.SP.26M	28	5 + 5 + 6 + 5 + 5	600	450	85	550	320

Note: Drawing and specification can be changed without notice for enhancement of product performance. Normal industries tolerances apply

ALUMINIUM LADDER

Suspension Ladders

These ladders are designed to be used in hanging position at the tower-cross arms for performing works, for instance at the insulator chains. They can be used also as anchoring ladders if supplied with the optional foldable conductor hook.

The tower hook is made of galvanized steel and equipped with a safety chain to prevent accidental fall down of the ladder.

The ladder itself is a welded structure of first grade extruded aluminium pipe. The rungs are corrugated for slip production.

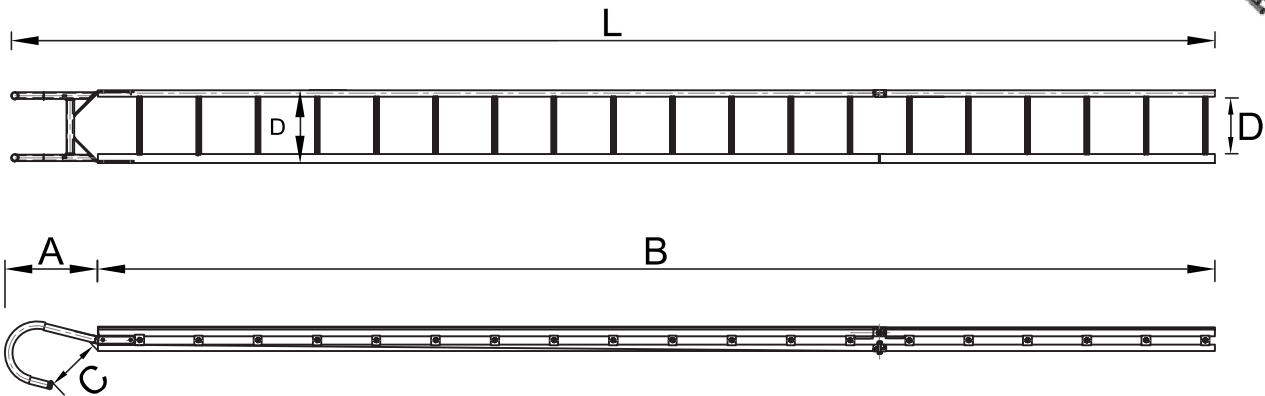
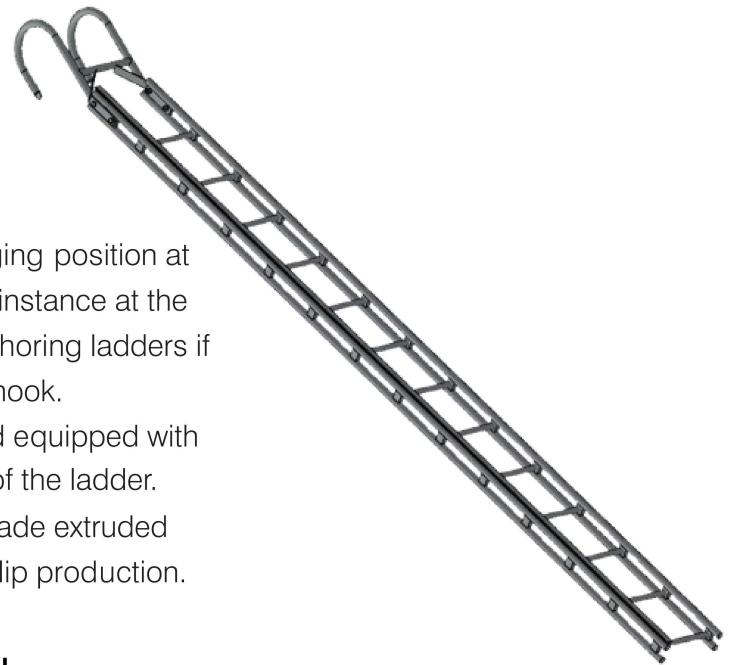

Different lengths and sections are available upon request.

Optional Equipment:

1. Swivel Tower Hook
2. Elastomer Lined Sheave in conductor Twisting Hook

Model No.	Total length (L)	Central Sections	Working load (kN)		A (mm)	B (mm)	C (mm)	D (mm)	Weight (kg)
			Horizontal	Vertical					
HG.SL.03M	3	1	1	3	500	900	245	300	29
HG.SL.3.5M	3.5	1	1	3	500	900	245	300	33
HG.SL.04M	4	1	1	3	500	900	245	300	37
HG.SL.05M	5	2	1	3	500	900	245	400	39
HG.SL.06*M	6	2	1	3	500	900	245	400	42
HG.SL.06M	6(4+2)	2	1	3	500	900	245	400	46
HG.SL.08M	8(4+4)	2	1	3	500	900	245	400	48
HG.SL.10M	10(5+5)	2	1	3	500	900	245	400	52
HG.SL.12M	12(4+4+4)	3	1	3	500	900	245	400	60

Note: Drawing and specification can be changed without notice for enhancement of product performance. Normal industries tolerances apply

ALUMINIUM LADDER

Anchoring Ladders

These ladders are used as working platform along the insulator chains of Tension Towers. If required they can be also used vertically as suspension ladders. Optionally we can equip these anchoring ladders with a foldable tower hook and different sheaves/ pulleys in the conductor hook for easier movement.

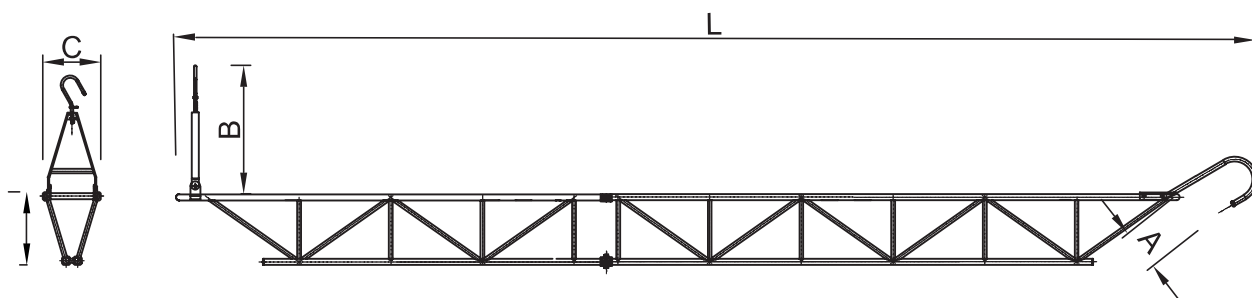
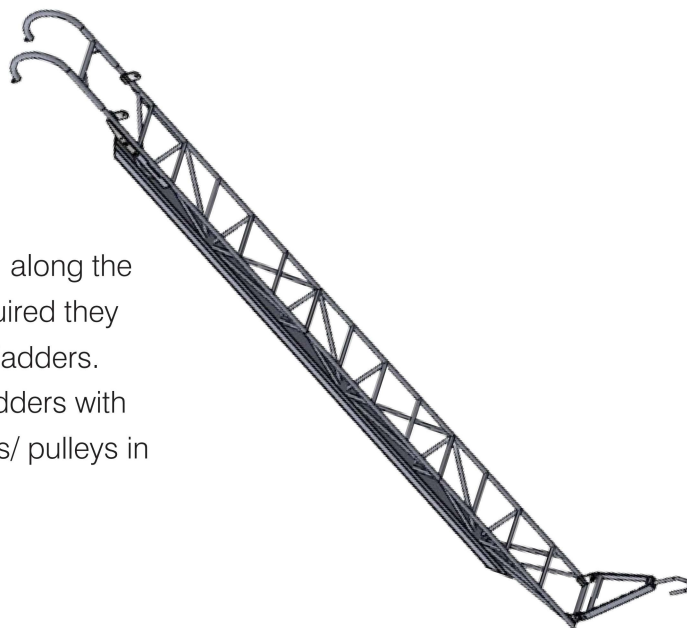

Different lengths and sections are available upon request.

Optional Equipment:

1. Swivel Tower Hook
2. Elastomer Lined Sheave in conductor Twisting Hook

Model No.	Total length (m)	Central Sections	Working load (kN)		A (mm)	B (mm)	C (mm)	D (mm)	Weight (kg)
			Horizontal	Vertical					
HG.AL.04M	4.0	1	3	3	245	900	320	350	29
HG.AL.05M	5.0	1	3	3	245	900	320	350	33
HG.AL.06M	6.0	1	3	3	245	900	320	350	37
HG.AL.06*M	6(4+2)	2	3	3	245	900	320	350	39
HG.AL.07M	7(4+3)	2	3	3	245	900	320	350	42
HG.AL.08M	8(4+4)	2	3	3	245	900	320	350	46

Note: Drawing and specification can be changed without notice for enhancement of product performance. Normal industries tolerances apply

GIN POLE

The Gin Pole is made of Light Aluminium alloy (TIG WELDED)

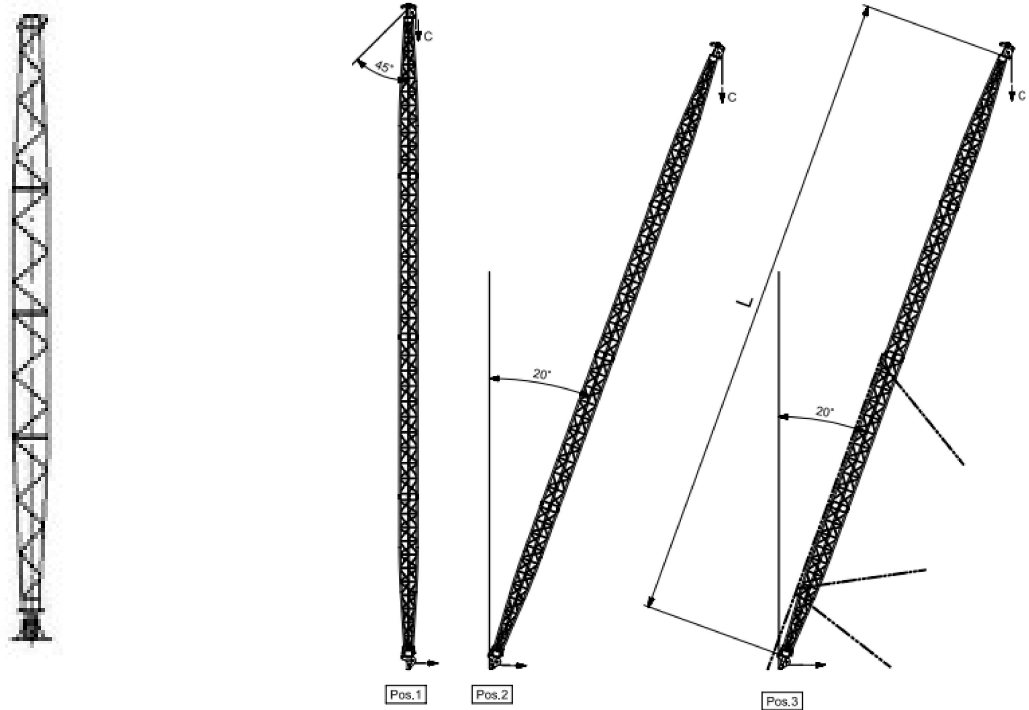

CUSTOMIZED GIN POLES CAN BE MANUFACTURE AS PER REQUIREMENT

Model No.	Capacity PN=T+C(kN)			TOTAL LENGTH (m)	STANDARD NUMBERS OF SECTIONS AND	WEIGHT (kg)
	PN1	PN2	PN3			
	POS.1	POS.2	POS.3			
	$\alpha=0^\circ$	$\alpha=20^\circ$	$\alpha=20^\circ$			
HGAC.GP.06.01	10	6	2.4	6	3+3	55
HGAC.GP.06.01	15	9	2.4	8	4+4	75
HGAC.GP.06.01	15	9	3.6	10	5+5	87
HGAC.GP.06.01	30	18	7.2	12	4+4+4	100
HGAC.GP.06.01	30	18	7.2	16	4+4+4+4	155
HGAC.GP.06.01	30	18	7.2	18	6+6+6	170
HGAC.GP.06.01	80	45	17	20	5+5+5+5	300
HGAC.GP.06.01	100	80	20	24	6+6+6+6	550

Note: Drawing and specification can be changed without notice for enhancement of product performance. Normal industries tolerences apply

SWIVEL JOINTS

The swivel joints are suitable for connecting the pulling rope to the mesh sock joint mounted on the conductor. They are mounted on thrust bearings and are designed to avoid torsion strain accumulation. They are made of highly tensile galvanized steel. The special design can bear the high radial loads which occur during stringing.

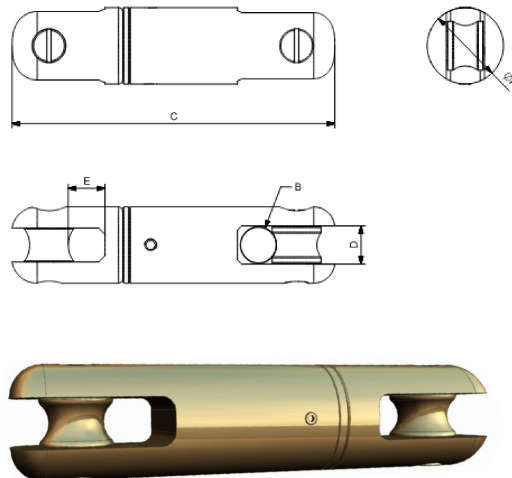

Model No.	Dimensions (mm)					Working Load (kN)	Breaking Load (kN)	Weight (kg)
	A	B	C	D	E			
HG.SJ.3T	31	14	124	16.5	14.5	10	30	0.500
HG.SJ.12T	36	16	152	17	16.5	37	120	0.75
HG.SJ.22T	45	20	192	22	21	74	220	1.6
HG.SJ.24T	50	24	189	25.5	24.5	100	240	1.9
HG.SJ.36T	60	26	256	27	29	120	360	3.4
HG.SJ.59T	72	28	325	30	38	180	550	8

PILOT WIRE CONNECTORS

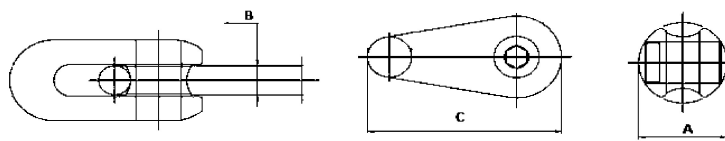
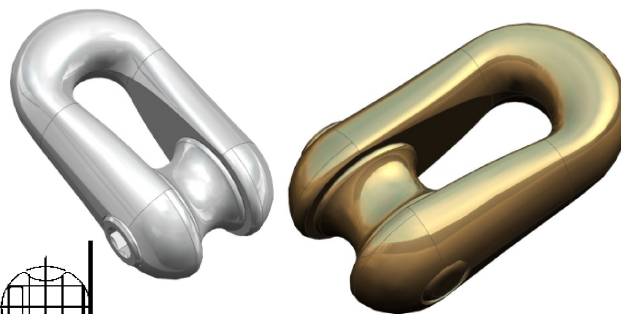

CAN MANUFACTURE, CUSTOMIZED ALSO PER APPLICATION OR CLIENT REQUIREMENT

The connectors are specifically designed to connect the pilot rope lengths/pulling rope lengths and to pass over the puller/puller-tensioner bull wheel groove. They are made of high tensile galvanized steel.

Model No.	Dimensions (mm)			Breaking Load (kN)	Weight (kg)
	A	B	C		
HG.PC.7T	59	28.2	10	7	0.13
HG.PC.11T	72.5	41	13	11	0.33
HG.PC.16T	90.5	48.5	16	16	0.53
HG.PC.22T	100.5	56	18	22	0.75
HG.PC.36T	119.5	60	24	36	1.03
HG.PC.75T	174	76.5	28	75	3.03

Note: Drawing and specification can be changed without notice for enhancement of product performance. Normal industries tolerances apply

CRIMPING DIE SET

Crimping dies are manufactured using high-grade steel with high precision and accuracy on CNC machines and are further heat treated to a hardness of 60 HRC. CNC Grinders are used for super finishing.

We offer dies for all conductor sizes and various types of power joint compression machines, with a 12 months' manufacturer's warranty.

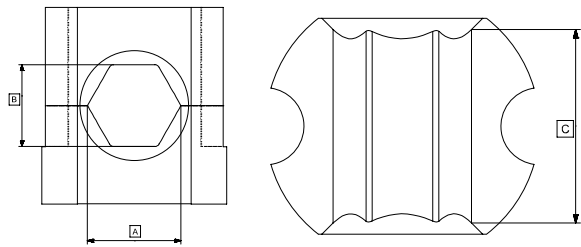
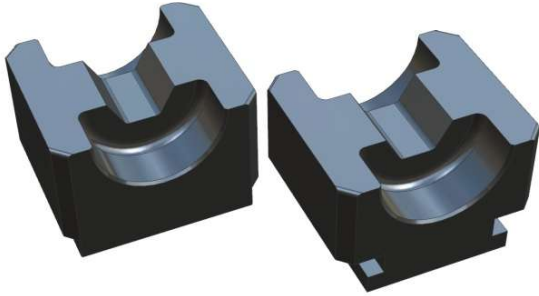

100 / 200 T ZECK / SANWA TEKKI like Power Joint Compression machine.

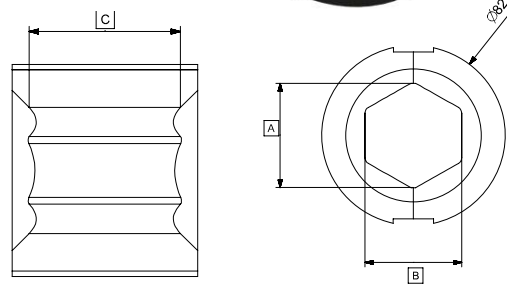
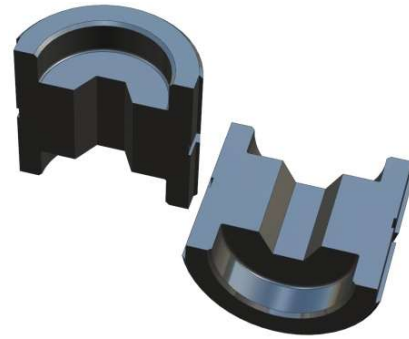

100/110/160 T POWER COM like Power Joint Compression machine

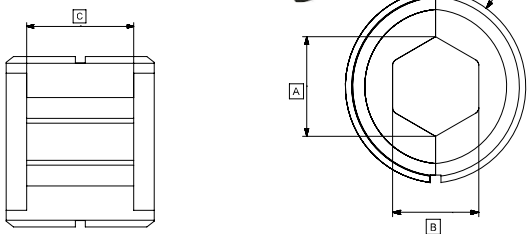
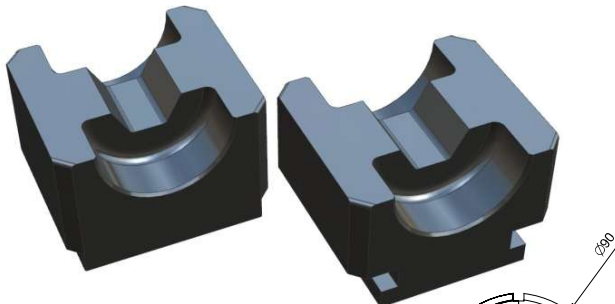

100/120/184 T TESMEC like Power Joint Compression machine

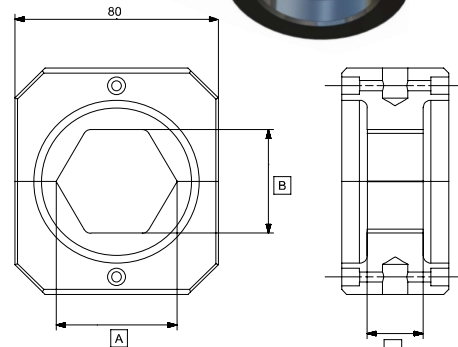
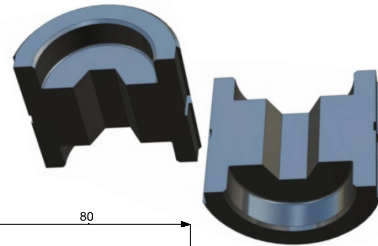

35 T KUDOS Power Joint Compression machine

* DIE SET ALSO AVAILABLE AS PER CUSTOMER JOINT COMPRESSION MACHINES

Note: Drawing and specification can be changed without notice for enhancement of product performance. Normal industries tolerances apply

PULLING GRIPS (SOCKS)

Single Head

The pulling grips are specifically designed in SINGLE HEAD TYPE to temporarily connect aluminum / steel / copper conductors to the pulling rope. They consist of variable pitch steel wire, which effectively distribute the gripping effect on the conductors.

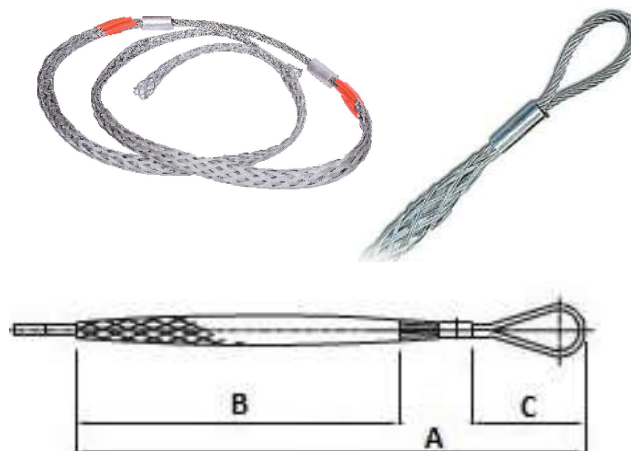

Model No.	Conductor Dia (mm)	Dimensions (mm)			Working load (kN)	Breaking Load (kN)	Weight (kg)
		A	B	C			
HG.S1.2T	8-17	1500	1200	160	12	36	0.7
HG.S2.8T	17-29	1900	1470	230	28	84	1.3
HG.S4.3T	29-38	1900	1470	230	43	129	2.1
HG.S6T	38-50	2270	1820	250	60	180	2.7

Double Head

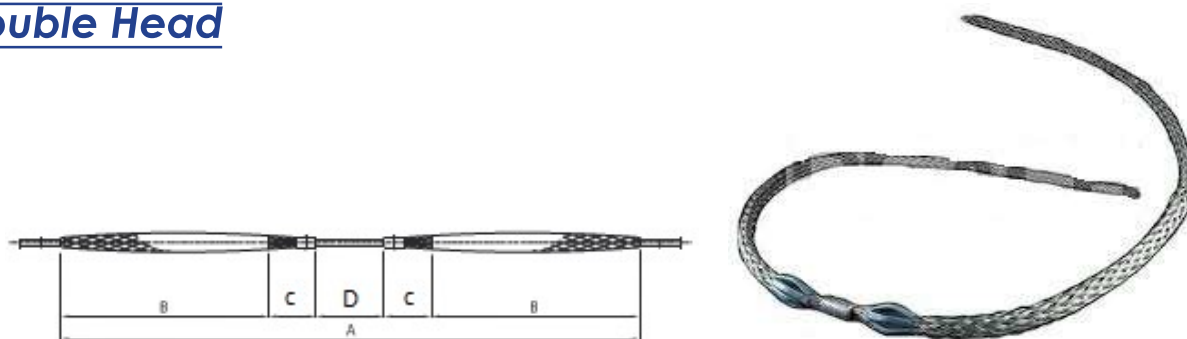

The pulling grips are specifically designed in DOUBLE HEAD TYPE to temporarily connect aluminum / steel / copper conductors to the pulling rope. They consist of variable pitch steel wire, which effectively distribute the gripping effect on the conductors.

Model No.	Conductor Dia (mm)	Dimensions (mm)				Working load (kN)	Breaking Load (kN)	Weight (kg)
		A	B	C	D			
HG.S1.2T	8-17	2680	1110	140	200	12	36	1.2
HG.S2.8T	17-29	3240	1360	160	200	28	84	2.3
HG.S4.3T	29-38	3540	1470	200	200	43	129	3.6
HG.S6T	38-50	4240	1820	200	200	60	180	4.8

* Customised grips can be made as per application.

Note: Drawing and specification can be changed without notice for enhancement of product performance. Normal industries tolerences apply

TURN BUCKLE



Turn Buckle comes in a seamless tube body, having modified square threads on end fittings for improved fatigue properties. Turnbuckle eyes are forged and elongated by design to maximize easy attachment in system and minimize stress in the eye.

Model No.	Capacity (ton)	Dimensions (mm)			Working load (kN)	Breaking Load (kN)	Weight (kg)
		Body	Open	Close			
HG.TB.3T	3	860	1733	1077	3	9	6.5
HG.TB.5T	5	860	1799	1123	5	15	9.2
HG.TB.10T	10	860	1839	1183	10	30	16
HG.TB.12T	12	860	1845	1189	10	30	19

FLAT CLAMP/ PATA CLAMP

These clamps are used for clamping the earth wire. The bodies of these clamps are made up of alloy steel. The dimensions of the grooves of the clamps are kept according to the diameter of the earth wire. The bolts are made up of high tensile steel.

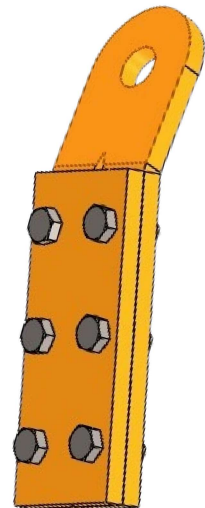

SPACER TROLLEY

Inspection line trolley fit for 2-4-6 bundle conductor lines is made of MS/Aluminium structure with Rubber lined aluminium sheaves mounted on ball bearing.

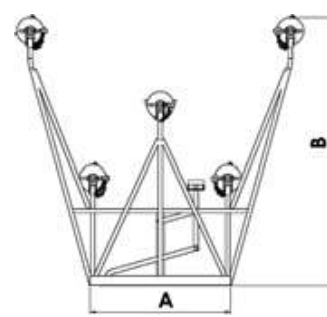
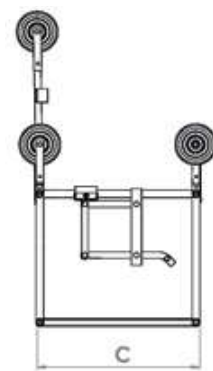
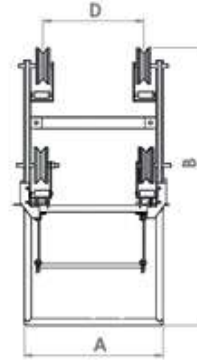
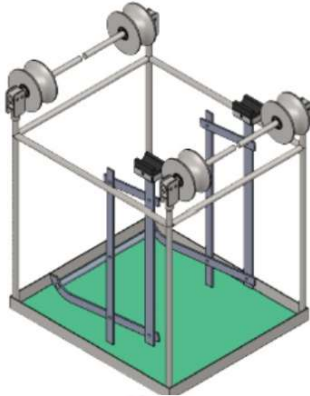

Model No.	Line Type	Length(A)	Height(B)	Width (C)	Weight (ALU./Ms)
HG.ST.2.	TWIN	610	710	630	20/38Kg
HG.ST.4.	QUAD	610	1228	630	24/44Kg
HG.ST.6.	HEXA	766	1444	1080	55/100Kg

* D (Spacer Width) will be manufactured as per requirement.

Optional devices:

- Distance meter
- Conductor clamp.

SPACER TROLLEY

Inspection line trolley fit for 2-4-6 bundle conductor lines is made of MS/Aluminium structure with Rubber lined aluminium sheaves mounted on ball bearing.

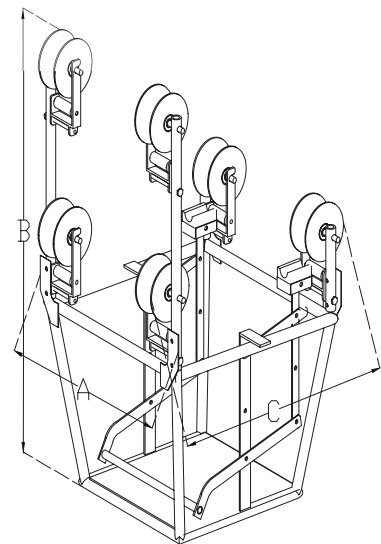
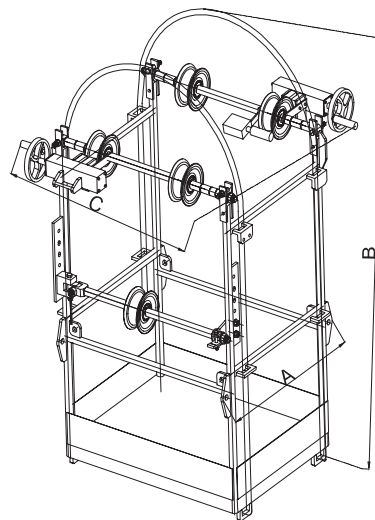
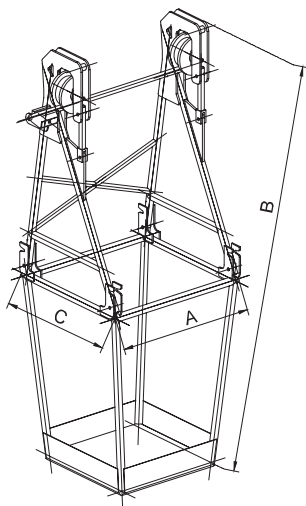
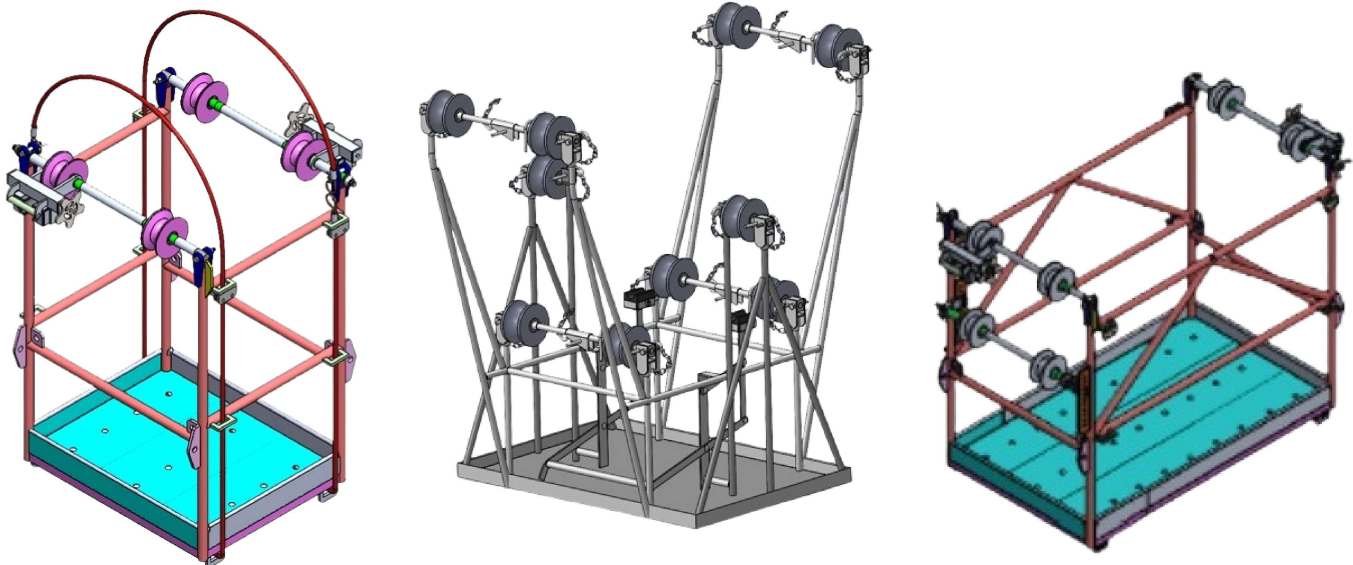

Model No.	Line Type	Length(A)	Height(B)	Width (C)	Weight
HG.ST.AL.2.	TWIN	480	1700	480	28Kg
HG.ST.AL.4.	QUAD	815	1548	650	24Kg
HG.ST.AL.6.	HEXA	473	1166	642	45Kg

* D (Spacer Width) will be manufactured as per requirement.

Optional devices:

- Distance meter
- Conductor clamp.

RUNNING EARTHS

This Grounding device is used during Stringing operations and is designed for conductors and Ropes. Copper grounding wire (35 & 50 Sq. mm) provided for connection to the ground. Can provide special groove and diameter as per conductor or rope as per applicable guide lines.

HGAC RE 001

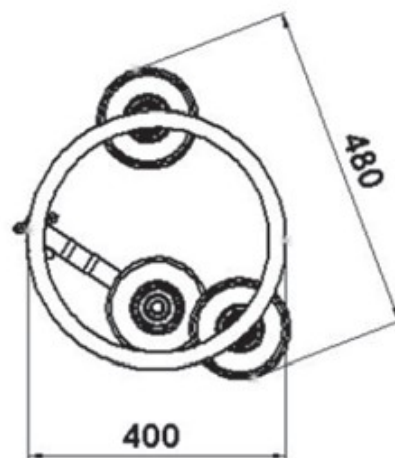

HGAC RE 001 Characteristics

Mass 6Kg
Groove width 55mm

HGAC RE 002

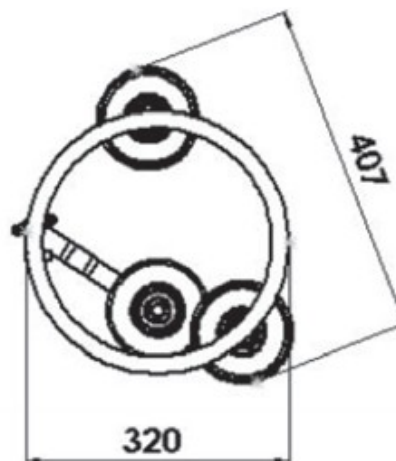

HGAC RE 002 Characteristics

Mass 16 Kg
Groove width 70 mm
Suitable for anti-twisting device model RFF001

DISCHARGE ROD COMPONENTS

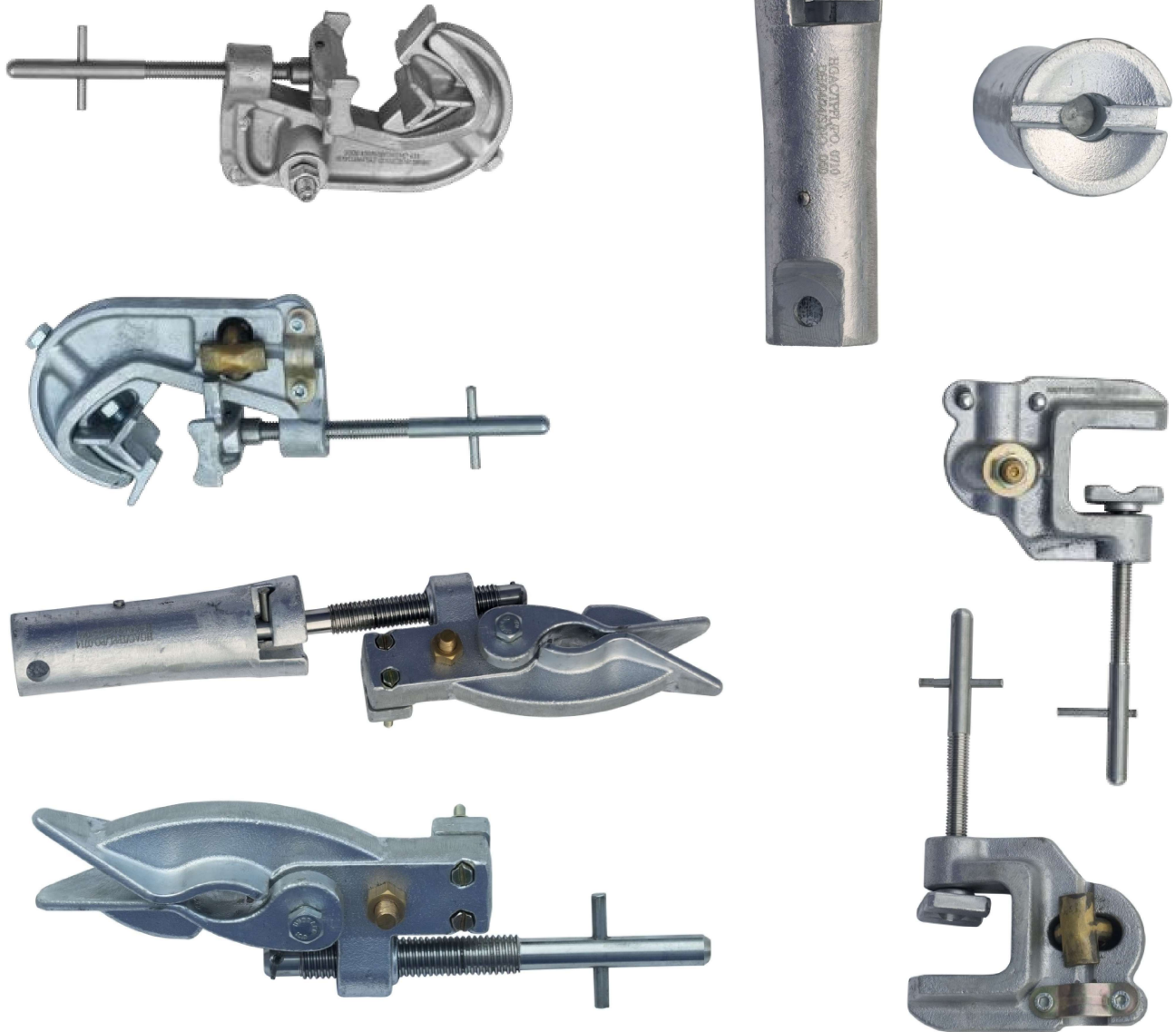

These components made from high strength high purity aluminium alloy gravity/chill cast components, fitted with SS, Copper and Bronze components for best performance in the field. These items are provided with 35 Sq. mm to 50 Sq. m copper wire as per customer requirement

PULLING EYE

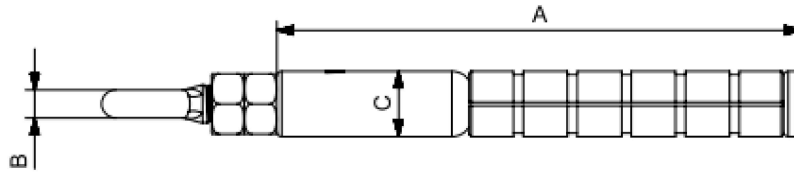

Model No.	Dimensions (mm)		DIA	WEIGHT (kg)
	A	B		
HG.PE.400KV	225	12	32	1.4
HG.PE.220KV	225	12	28	1.2

Note: Drawing and specification can be changed without notice for enhancement of product performance. Normal industries tolerances apply

NYLON SECTOR

We Match Required Radius of the Tensioner Bull Wheel Sector as Per Radius of conductor (For HVCR®(High Voltage Composite Reinforced Conductors) Conductor Special Conductor, ACCC Carbon Core Conductor and other HTLS Conductors) which also at times allows for minimum of Four grooves in existing Tensioner or minimum of four grooves in existing tensioner.



Note: Drawing and specification can be changed without notice for enhancement of product performance. Normal industries tolerances apply

TESTING FACILITY

We are having in house facility and our testing lab is equipped with:

UNIVERSAL TESTING MACHINE (UTM)



SPECTROMETER



ROCKWELL & BRINELL HARDNESS TESTER



TESTING EQUIPMENT



ULTRASONIC TESTING MACHINE (UT)



MAGNETIC PARTICLE INSPECTION (MPI)



TENSILE TESTING FOR RUBBER, POLY URETHANE, NYLON AND OTHER POLYMERS".



MACHINE FACILITY

ELECTRICAL FURNACES FOR GRAVITY



CNC



LASER MARKING MACHINE



VMC



NYLON CASTING MACHINE



DIE CASTING MACHINE



PU CASTING MACHINE



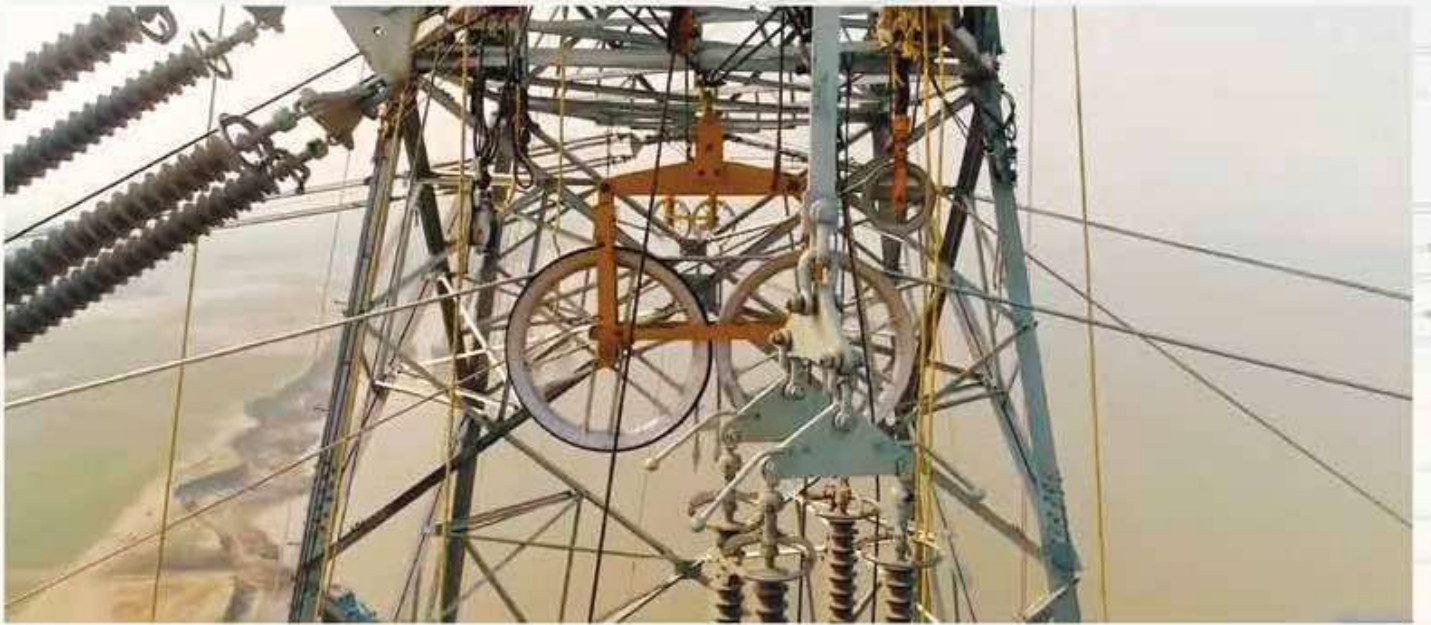

HIND GOLD AUTOMOTIVE COMPONENTS

