

Contents



Butterfly Valve



04	Products	23	Lug Butterfly Valve (Through Shaft Without Pin)
06	Butterfly Valve		
08	Wafer Butterfly Valve (Two Holes)	24	Lug Butterfly Valve (Half Shaft Without Pin)
09	Wafer Butterfly Valve		
10	Wafer Butterfly Valve (AS2129)	25	Lug Butterfly Valve (Through Shaft Without Pin)
11	U-Type Butterfly Valve		
14	Wafer Butterfly Valve (Half Shaft Without Pin)	26	Lug Butterfly Valve (Through Shaft Without Pin)
15	Wafer Butterfly Valve (Through Shaft Without Pin)	27	PTFE Coated Butterfly Valve (Lug Type)
18	Wafer Butterfly Valve(Four Holes With Tongue-And-Groove Seat)	28	Concentric Flanged Butterfly Valve
19	Wafer Butterfly Valve(Two Holes With Tongue-And-Groove Seat)	29	Grooved End Butterfly Valve
20	PTFE Coated Butterfly Valve (Wafer Type)	30	Resilient Seated Eccentric Flanged Butterfly Valve
		32	Metal Seated Eccentric Butterfly Valve (Wafer Type)
		33	Metal Seated Eccentric Butterfly Valve (Flange Type)

Gate Valve



34	Gate Valve	40	BS5150/BS5163
36	Non-Rising Stem Solid Wedge Gate Valve (ANSI B16.10)	41	Rising Stem Resilient Seated Gate Valve (ANSI B16.10)
37	Non-Rising Stem Solid Wedge Gate Valve (BS5150)	42	Rising Stem Resilient Seated Gate Valve (BS5163)
38	Non-Rising Stem Metal Seated Gate Valve (DIN 3202 F4/F5)	43	Rising Stem Resilient Seated Gate Valve (DIN3202-F4/F5)
39	Rising Stem Solid Wedge Gate Valve (ANSI B16.10)		



Gate Valve



- 44 Non-Rising Stem Gate Valve With Changeable O-Ring (BS5163)
- 45 Non-Rising Stem Resilient Seated Gate Valve With Changeable O-Ring (DIN3202-F4/F5)

Check Valve



- 46 Check Valve
- 48 Dual Plate Wafer Check Valve
- 49 Swing Check Valve (ANSI B16.10)
- 50 Swing Check Valve (BS5153)
- 51 Swing Check Valve (DIN 3202 F6)
- 52 DIN Cast Iron Silent Check Valve PN16

Globe Valve



- 53 Globe Valve (ANSI B16.10)
- 54 Globe Valve (BS5152)

Y-Strainer



- 55 Y-Strainer
- 56 Y-Strainer (DIN 3202 F1)

Flange



- 57 Flange (For Butterfly Valve)
- 58 Flange (Flat Welding)
- 61 **Ball Valve**
- 62 **Foot Valve (DIN PN16)**

Rubber Expansion Joint



- 59 Single Sphere Connector With Flange
- 60 Twin Sphere Connector With Thread
- 63 **Dismantling Joint**
- 64 **CERTIFICATE**



Wafer Butterfly Valve
(Two Holes)



U-Type
Butterfly Valve



Wafer Butterfly Valve
(AS2129)



Wafer Butterfly Valve(Four Holes
With Tongue-And-Groove Seat)



Lug Butterfly Valve
(Half Shaft Without Pin)



Lug Butterfly Valve
(Through Shaft Without Pin)



Concentric Flanged
Butterfly Valve



Metal Seated Butterfly Valve
(Wafer Type)



Metal Seated Butterfly Valve
(Flange Type)



Non-Rising Stem Solid Wedge Gate Valve (BS5150)



Rising Stem Resilient Gate Valve (ANSI B16.10)



Non-Rising Stem Gate Valve With Changeable O-Ring (DIN3202-F5)



Swing Check Valve (BS5153)



Dual Plate Wafer Check Valve



GLOBE VALVE (ANSI B16.10)



Resilient Seated Eccentric Flanged Butterfly Valve



RUBBER EXPANSION JOINT



Y-STRAINER (DIN3202 F1)

• CONCENTRIC BUTTERFLY VALVE



- Water works and water resource project
- Environment protection
- Public facilities
- Power and public utilities
- Building industry
- Petroleum, chemical
- Steel, metallurgy
- Paper making industry
- Foods, Beverage



Butterfly valve as used as shutting-off or throttling unit for petroleum processing, chemicals, food, medicine, textile, paper making, hydroelectricity engineering as well as light industry, etc. it can be installed in any selected position.

Through precise manufacturing, the main parts of this butterfly valve ensure valve's operation in long stable and reliable condition

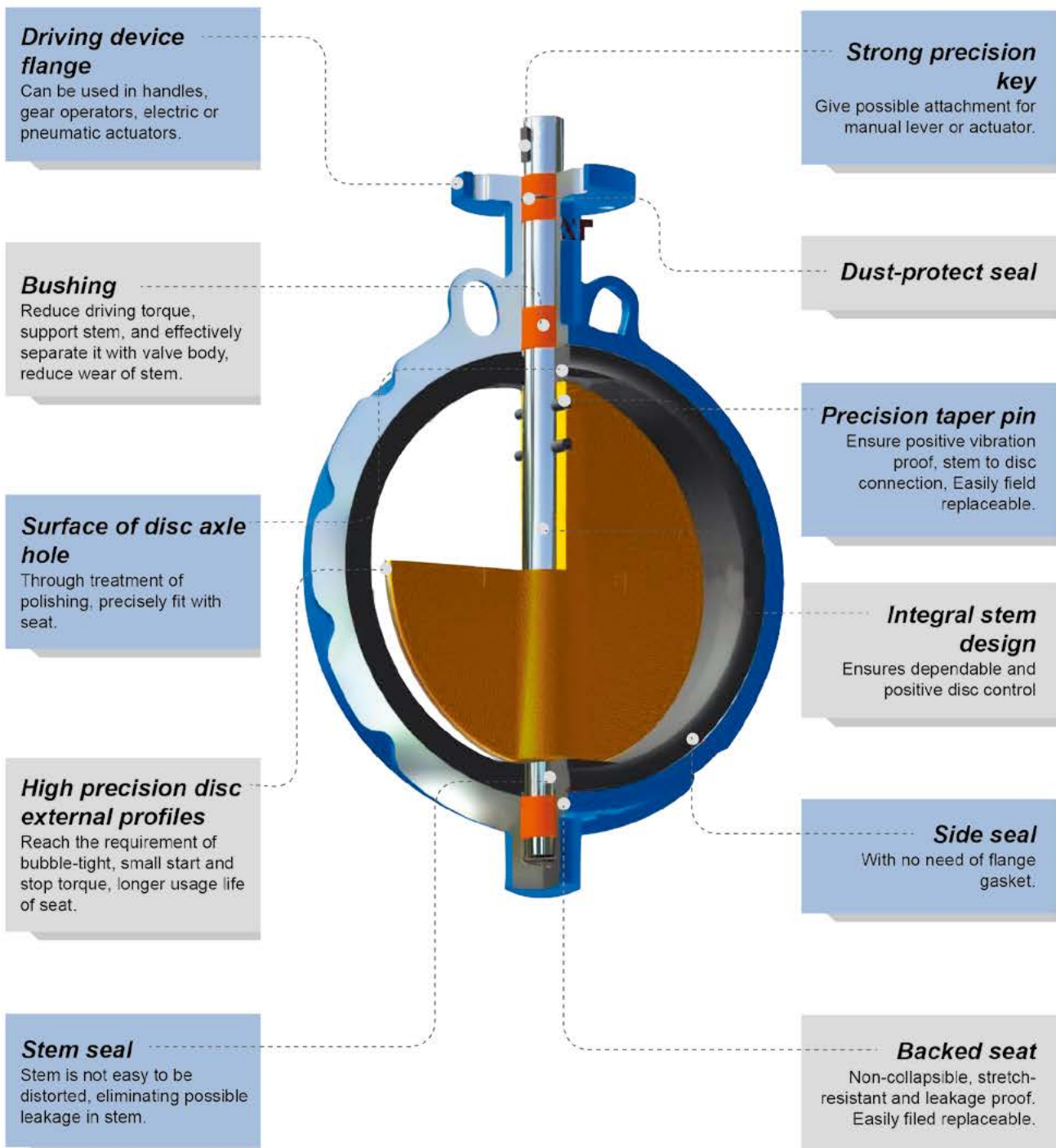



Wafer Butterfly Valve (Two Holes)

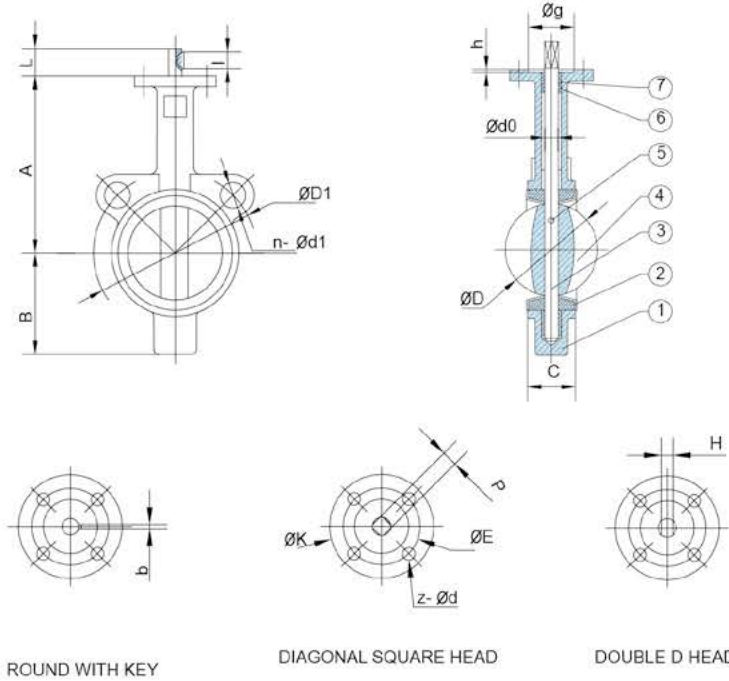

- Type:
Wafer
- Face to Face:
API609,BS5155,DIN3202, ISO5752
- Flange:
DIN,BS,UNI,ISO,ANSI, AS,JIS
- Mounting Flange:
ISO5211

- Working Pressure:
PN16(200PSI)
- Application:
Water works, Public facilities, Building Industry, Petroleum, Chemical, Steel, Metallurgy, Paper Making Industry, Foods, Beverage

STANDARD MATERIALS OF MAIN PARTS

NO.	PART	MATERIAL
1	Body	Cast Iron ,Ductile Iron ,Carbon Steel ,Stainless Steel
2	Seat	NBR,EPDM,Viton,Neoprene ,Hypalon,Silicon
3	Shaft	Stainless Steel416,316,304
4	Disc	Ductile Iron +Ni,CF8,CF8M,Bronze
5	Pin	Stainless Steel
6	Bushing	PTFE,Bronze
7	O Ring	NBR,EPDM

DIMENSIONS

SIZE	in	DN	A	B	C	D	L	d0	P	H	key				UPPER FLANGE				ANSI 150		DIN PN10/16	
											bxl	K	E	z-d	g	h	D1	n-ød1	D1	n-ød1		
2	50	140	80	42	52.6	32	126	9	10	3X16	77	50	4.7	35	3	120.5	4-19	125	4-18			
2-1/2	65	152	89	44.7	64.5	32	126	9	10	3X16	77	50	4.7	35	3	139.5	4-19	145	4-18			
3	80	159	95	45.2	78.8	32	126	9	10	3X16	77	50	4.7	35	3	152.5	4-19	160	48-18			
4	100	178	114	52.1	104	32	157.7	11	12	5X19	90	70	4.9	55	3	190.5	8-19	180	8-18			
5	125	190	127	54.4	123.3	32	189.2	14	14	5X19	90	70	4.9	55	3	216	8-22	210	8-18			
6	150	203	139	55.8	155.6	32	189.2	14	14	5X19	90	70	4.9	55	3	241.5	8-22	240	8-23			
8	200	238	175	60.6	202.5	45	221	17	17	5X19	125	102	4-12	70	3.5	298.5	8-22	295	8-12-23			
10	250	268	203	65.6	250.5	45	284.5	22	22	8X28	125	102	4-12	70	3.5	362	12-25	350/355	12-23/27			
12	300	306	242	76.9	301.6	45	316	22	24	8X28	125	102	4-12	70	3.5	432	12-25	400/410	12-23/27			



Wafer Butterfly Valve

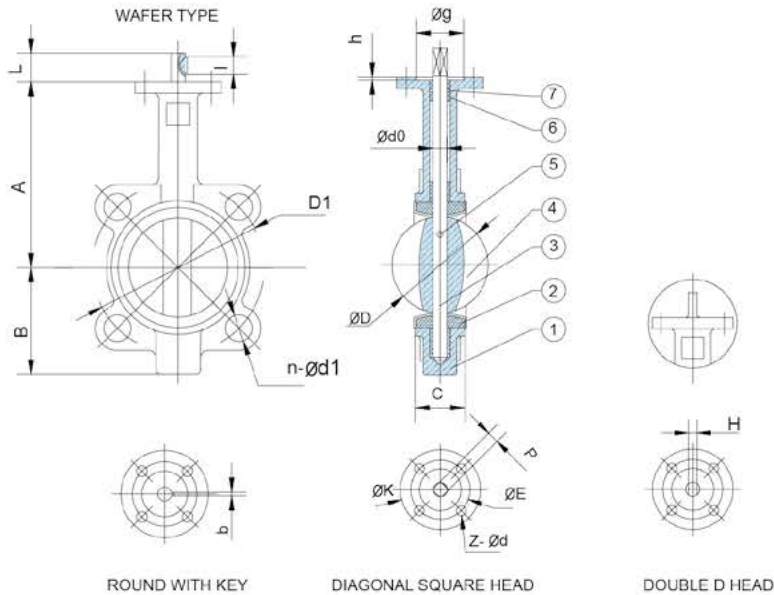

- Type:
Wafer
- Face to Face:
API609,BS5155,DIN3202, ISO5752
- Flange:
DIN,BS,UNI,ISO,ANSI, AS,JIS
- Mounting Flange:
ISO5211

- Working Pressure:
PN16(200PSI)
- Application:
Water works, Public facilities, Building Industry, Petroleum, Chemical, Steel, Metallurgy, Paper Making Industry, Foods, Beverage

STANDARD MATERIALS OF MAIN PARTS

NO.	PART	MATERIAL
1	Body	Cast Iron ,Ductile Iron ,Carbon Steel ,Stainless Steel
2	Seat	NBR,EPDM,Viton,Neoprene ,Hypalon,Silicon
3	Shaft	Stainless Steel416,316,304
4	Disc	Ductile Iron +Ni,CF8,CF8M,Bronze
5	Pin	Stainless Steel
6	Bushing	PTFE,Bronze
7	O Ring	NBR,EPDM

DIMENSIONS

SIZE in DN	A	B	C	D	L	d0	P	H	key bxl	UPPER FLANGE					ANSI 150		DIN PN10/16		
										K	E	z	d	g	h	D1	n-ød1	D1	n-ød1
1-12	40	145	75	33	42.4	32	12.6	-	-	3X16	77	50	4.7	35	3	98.5	4-16	110	4-18
2	50	161	80	42	52.6	32	12.6	9	10	3X16	77	50	4.7	35	3	120.5	4-19	125	4-18
2-12	65	175	89	44.7	64.5	32	12.6	9	10	3X16	77	50	4.7	35	3	139.5	4-19	145	4-18
3	80	181	95	45.2	78.8	32	12.6	9	10	3X16	77	50	4.7	35	3	152.5	4-19	160	4-18
4	100	200	114	52.1	104	32	15.77	11	12	5X19	90	70	4.9	55	3	190.5	8-19	180	8-18
5	125	213	127	54.4	123.3	32	18.92	14	14	5X19	90	70	4.9	55	3	216	8-22	210	8-18
6	150	226	139	55.8	155.6	32	18.92	14	14	5X19	90	70	4.9	55	3	241.5	8-22	240	8-23
8	200	260	175	60.6	202.5	45	22.1	17	17	5X19	125	102	4.12	70	3.5	298.5	8-22	295	8-12-23
10	250	292	203	65.6	250.5	45	28.45	22	22	8X28	125	102	4.12	70	3.5	362	12-25	350/355	12-23-27
12	300	337	242	76.9	301.6	45	31.6	22	24	8X28	140	102	4.12	70	3.5	432	12-25	400/410	12-23/27
14	350	368	267	76.5	333.3	45	31.6	22	24	8X28	140	102	4.12	70	3.5	476	12-29	460/470	16-23/27
16	400	400	309	86.5	389.6	51.2/72	33.15/38	24	24	10X50	175	140	4.18	100	4	540	16-29	515/525	16-27/30
18	450	422	328	105.6	440.5	51.2/72	38/42.86	27	27	10X50	175	140	4.18	100	4	578	16-32	565/585	20-27/30
20	500	490	361	131.8	491.6	64.2/82	41.15/45.72	32	32	10X50	175	140	4.18	100	4	635	20-32	620/650	20-27/33
24	600	562	459	152	592.5	70.2/82	50.65/53.98	36	36	2-18X60	210	165	4.23	130	5	749.5	20-35	725/770	20-30/36
28	700	624	520	163	695	66/82	55/63.35	-	-	2-18X63	300	254	8-18	200	5.5	863.5	28-35	840	24-30/36
30	750	680	539	165	744.3	66/82	55/63.35	-	-	2-18X63	300	254	8-18	200	5.5	914.5	28-35	-	-
32	800	672	591	188	794.7	66/82	55/63.35	-	-	2-18X63	300	254	8-18	200	5.5	978	28-41	950	24-33/39
36	900	720	656	203	864.7	118	75	-	-	2-20X100	300	254	8-18	200	5.5	1086	32-41	1050	28-33/39
40	1000	800	721	216	965	142	85	-	-	2-20X100	300	254	8-18	200	5.5	1200	36-41	1180/1170	28-36/42





- Type:
Wafer
 - Face to Face:
API609,BS5155,DIN3202, ISO5752
 - Flange:
AS2129 Table E/D
 - Mounting Flange:
ISO5211
-
- Working Pressure:
PN16(200PSI)
 - Application:
Water works, Public facilities, Building Industry, Petroleum, Chemical, Steel, Metallurgy, Paper Making Industry, Foods, Beverage.



Wafer Butterfly Valve (AS2129)

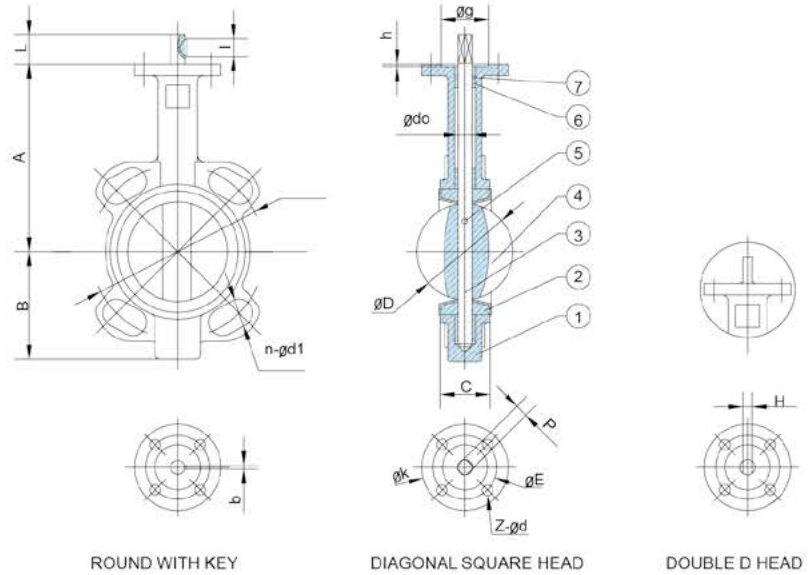

STANDARD MATERIALS OF MAIN PARTS

NO.	PART	MATERIAL
1	Body	Cast Iron ,Ductile Iron ,Carbon Steel ,Stainless Steel
2	Seat	NBR,EPDM,Viton,Neoprene ,Hypalon,Silicon
3	Shaft	Stainless Steel416,316,304
4	Disc	Ductile Iron +Ni,CF8,CF8M,Bronze
5	Pin	Stainless Steel
6	Bushing	PTFE,Bronze
7	O Ring	NBR,EPDM

DIMENSIONS

SIZE		A	B	C	D	L	d0	P	H	key	UPPER FLANGE					ANSI 150		AS2129-D		AS2129-E	
in	DN									bxl	K	E	z-ød	g	h	D1	n-ød1	D1	n-ød1	D1	n-ød1
2	50	130.5	66.5	42	52.6	32	12.6	9	10	3x16	77	50	4-7	35	3	120.5	4-19	114	4-18	114	4-18
2-1/2	65	140	71	44.7	64.5	32	12.6	9	10	3x16	77	50	4-7	35	3	139.5	4-19	127	4-18	127	4-18
3	80	150	83	45.2	78.8	32	12.6	9	10	3x16	77	50	4-7	35	3	152.5	4-19	146	4-18	146	4-18
4	100	163	95	52.1	104	32	15.77	11	12	5x19	90	70	4-9	55	3	190.5	8-19	178	4-18	178	8-18
5	125	178	110	54.4	123.3	32	18.92	14	14	5x19	90	70	4-9	55	3	216	8-22	210	8-18	210	8-18
6	150	191	124	55.8	155.6	32	18.92	14	14	5x19	90	70	4-9	55	3	241.5	8-22	235	8-18	235	8-22
8	200	239	163	60.6	202.5	45	22.1	17	17	5x19	125	102	4-12	70	3.5	298.5	8-22	292	8-18	292	8-22
10	250	285	227	65.6	250.5	45	28.45	22	22	8x28	125	102	4-12	70	3.5	362	12-25	356	8-22	356	12-22
12	300	315	252	76.9	301.6	45	31.6	22	24	8x28	125	102	4-12	70	3.5	432	12-25	406	12-22	406	12-26

U-Type Butterfly Valve

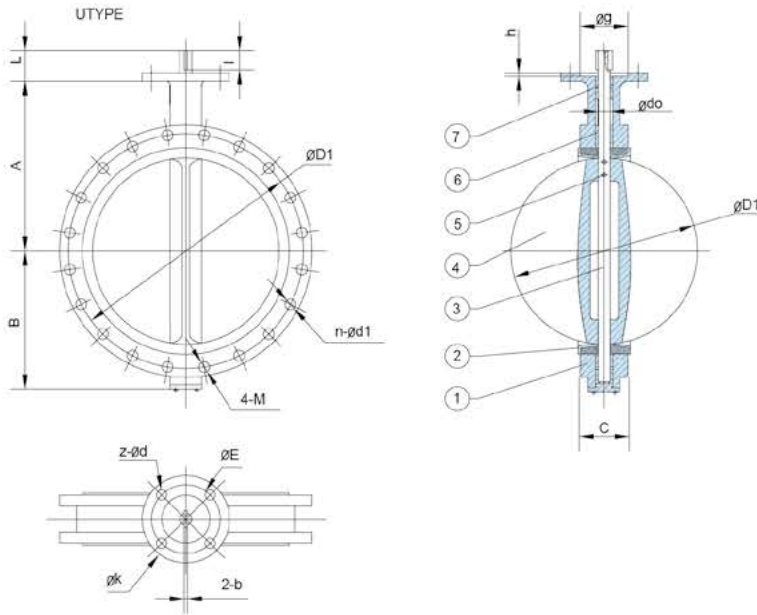

STANDARD MATERIALS OF MAIN PARTS

NO.	PART	MATERIAL
1	Body	Cast Iron ,Ductile Iron ,Carbon Steel ,Stainless Steel
2	Seat	NBR,EPDM,Viton,Neoprene ,Hypalon,Silicon
3	Shaft	Stainless Steel 416,316,304
4	Disc	Ductile Iron +Ni,CF8,CF8M,Bronze
5	Pin	Stainless Steel
6	Bushing	PTFE,Bronze
7	O Ring	NBR,EPDM

DIMENSIONS

SIZE in DN	A	B	C	D	L	D0	KEY 2-bXl	UPPER FLANGE				ANSI150			DIN PN10/PN16				
								K	E	z-Ød	g	h	D1	n-Ød1	4-M	D1	n-Ød1	4-M	
16	400	400	309	86.5	388.6	51.2/72	33.15/38	1-10X50	175	140	4.18	100	4	540	16.29	-	515/525	16-27/30	-
18	450	422	328	105.6	440.5	51.2/72	38.4/28.6	1-10X50	175	140	4.18	100	4	578	16.32	-	565/585	20-27/30	-
20	500	490	361	131.8	491.6	53.78	41.15/45.72	1-10X50	175	140	4.18	100	4	635	20.32	-	620/650	20-27/33	-
24	600	562	459	152	592.5	70.2/82	50.65/53.98	2-16X60	210	165	4.23	130	5	749.5	20.35	-	725/770	20-30/36	-
28	700	624	520	163	695	66/82	55.63/35	2-18X63	300	254	8.18	200	5.5	863.5	24.35	4-11/4"	840	20-30/36	4-M27/M33
30	750	660	539	165	744.3	66/82	55.63/35	2-18X63	300	254	8.18	200	5.5	914.5	24.35	4-11/4"	-	-	-
32	800	672	591	188	794.7	66/82	55.63/35	2-18X63	300	254	8.18	200	5.5	978	24.41	4-11/2"	950	20-33/39	4-M30/M36
36	900	720	655	203	864.7	118	75	2-20X100	300	254	8.18	200	5.5	1086	28.41	4-11/2"	1050	24-33/39	4-M30/M36
40	1000	800	721	216	965	142	85	2-22X140	300	254	8.18	200	5.5	1200	32.41	4-11/2"	1160/1170	24-36/42	4-M33/M39
42	1050	858	757	251	1030.5	150	95	2-25X140	300	254	8.18	200	5.5	1257.5	32.41	4-11/2"	-	-	-
48	1200	941	844	276	1161.2	150	105	2-28X140	350	298	8.23	230	5.5	1422.5	40.41	4-11/2"	1380/1390	28-38/48	4-M36/M45



- Type:
U-type
- Face to Face:
BS5155,DIN3202, ISO5752
- Flange:
DIN,BS,UNI,ISO,ANSI, AS,JIS
- Mounting Flange:
ISO5211

- Working Pressure:
PN16(200PSI)
- Application:
Water works, Public facilities, Building Industry, Petroleum, Chemical, Steel, Metallurgy, Paper Making Industry, Foods, Beverage



• CONCENTRIC BUTTERFLY VALVE



- Water works and water resource project
- Environment protection
- Public facilities
- Power and public utilities
- Building industry
- Petroleum, chemical
- Steel, metallurgy
- Paper making industry
- Foods, Beverage



Butterfly valve as used as shutting-off or throttling unit for petroleum processing, chemicals, food, medicine, textile, paper making, hydroelectricity engineering as well as light industry, etc. it can be installed in any selected position.

Type: Wafer, Lugged
 Face to Face: AP1609, BS5155, DIN3202, ISO 5752
 Flange: DIN, BS, UNI, ISO, ANSI, AS, JIS
 Mounting Flange: ISO5211

Working Pressure: PN16(200PSI)
 Application: Water works, Public facilities, Building Industry, Petroleum, Chemical, Steel, Metallurgy, Paper Making Industry, Foods, Beverage

Weather Seal

Top bushing keeps dust and moisture from entering the upper shaft journal.

Shaft

Two stub shaft design allows the disc to float within the flow-way inc easing cycle life.

Bushing(6)

Shaft bushing reduce torque and isolate the shaft from the valve body preventing seizure of the shaft due to corrosion in the shaft journal.

Seat Face

Seat to flange seal eliminates the need for flange gaskets.

Seat

Phenolic-backed seat is non-collapsible, stretch resistant, blow out proof, and field replaceable

Mounting Flange

ISO 5211 mounting flange accommodates direct mounting of all types of actuators, including handles, gear operators, electric and pneumatic.

O-Ring(2)

Shaft seal provides further assurance against stem leakage.

Hub Seal

Smooth finished disc flats mate with seat flats to give a highly efficient prevents leakage into the shaft area.

Disc

Precision profile provides bubble-tight shut-off, assures minimum torque and longer seat life. Maximum flow is achieved.

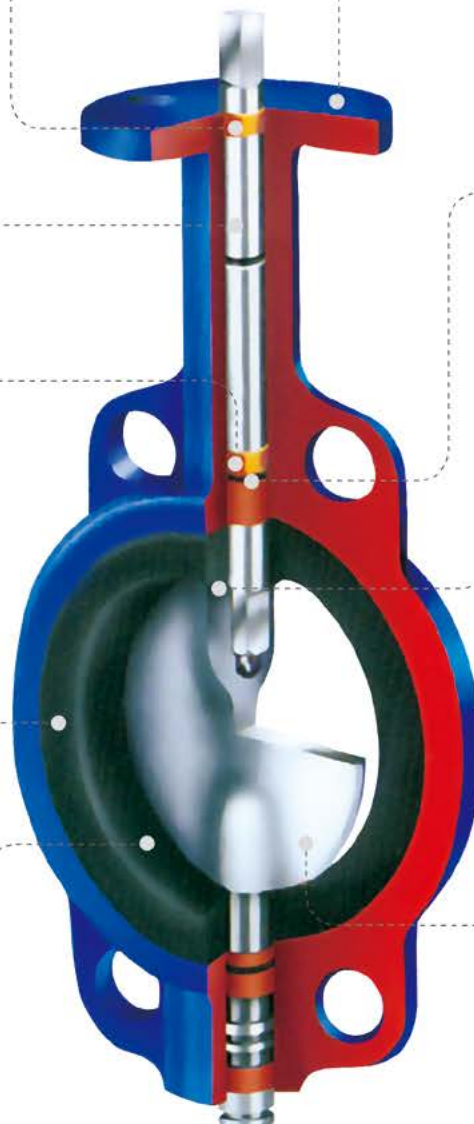



- Type:
Wafer
- Face to Face:
API609,BS5155,DIN3202, ISO5752
- Flange:
DIN,BS,UNI,ISO,ANSI, AS,JIS
- Mounting Flange:
ISO5211

- Working Pressure:
PN16(200PSI)
- Application:
Water works, Public facilities, Building Industry, Petroleum, Chemical, Steel, Metallurgy, Paper Making Industry, Foods, Beverage



Wafer Butterfly Valve (Half Shaft Without Pin)

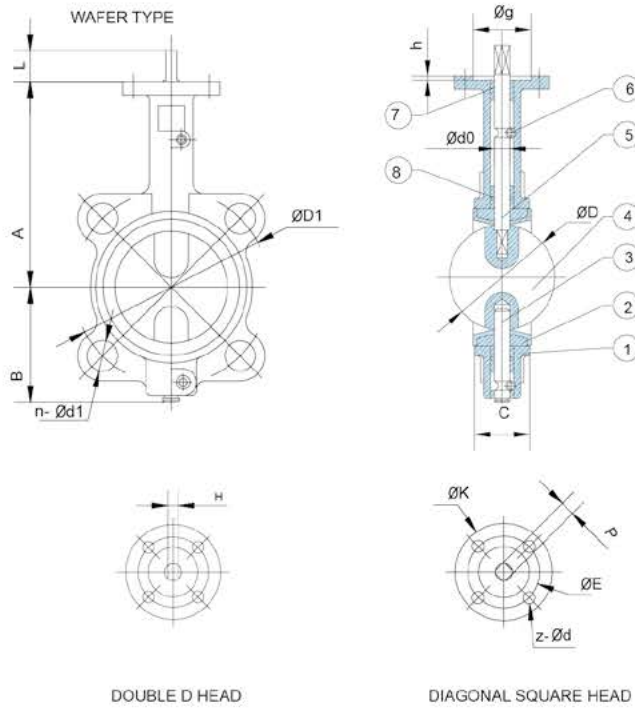

STANDARD MATERIALS OF MAIN PARTS

NO.	PART	MATERIAL
1	Body	Cast Iron, Ductile Iron, Carbon Steel, Stainless Steel
2	Seat	NBR, EPDM, PTFE, Viton, Neoprene, Hypalon, Silicon
3	lower Shaft	Stainless Steel 416, 316, 304
4	Disc	Ductile Iron+Ni(Nylon/Epoxy), CF8, CF8+PTFE(PFA), CF8M, CF8M+PTFE(PFA), Bronze
5	Upper Shaft	Stainless Steel 416, 316, 304
6	Locating Pin	Carbon Steel
7	Bushing	PTFE
8	O Ring	NBR, EPDM

DIMENSIONS

SIZE		A	B	C	D	L	d0	P	H	UPPER FLANGE				ANSI 150		DIN PN10/16		
IN	DN									K	E	z-d	g	h	D1	n-d1	D1	n-d1
2	50	161	80	42	52.6	32	12.6	9	10	77	50	4-7	35	3	120.5	4-19	125	4-18
2-1/2	65	175	89	44.7	64.5	32	12.6	9	10	77	50	4-7	35	3	139.5	4-19	145	4-18
3	80	181	95	45.2	78.8	32	12.6	9	10	77	50	4-7	35	3	152.5	4-19	160	4/8-18
4	100	200	114	52.1	104	32	15.77	11	12	90	70	4-9	55	3	190.5	8-19	180	8-18
5	125	213	127	54.4	123.3	32	18.92	14	14	90	70	4-9	55	3	216	8-22	210	8-18
6	150	226	139	55.8	155.6	32	18.92	14	14	90	70	4-9	55	3	241.5	8-22	240	8-23
8	200	260	175	60.6	202.5	45	22.1	17	17	125	102	4-12	70	3.5	298.5	8-22	295	8/12-23
10	250	292	203	65.6	250.5	45	28.45	22	22	125	102	4-12	70	3.5	362	12-25	350/355	12-23/27
12	300	337	242	76.9	301.6	45	31.6	22	24	125	102	4-12	70	3.5	432	12-25	400/410	12-23/27

Wafer Butterfly Valve (Through Shaft Without Pin)

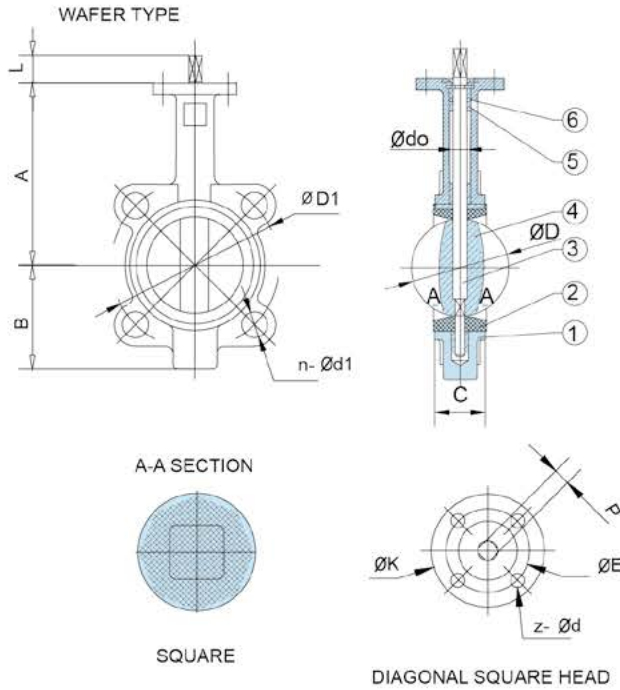

- Type:
Wafer
- Face to Face:
API609,BS5155,DIN3202, ISO5752
- Flange:
DIN,BS,UNI,ISO,ANSI, AS,JIS
- Mounting Flange:
ISO5211

- Working Pressure:
PN16(200PSI)
- Application:
Water works, Public facilities, Building Industry, Petroleum, Chemical, Steel, Metallurgy, Paper Making Industry, Foods, Beverage

STANDARD MATERIALS OF MAIN PARTS

NO.	PART	MATERIAL
1	Body	Cast Iron, Ductile Iron, Stainless Steel
2	Seat	EPDM,NBR,Viton
3	Shaft	Stainless Steel 416,316,304
4	Disc	DI+NI,CF8,CF8M
5	Bushing	PTFE
6	O Ring	NBR

DIMENSIONS

SIZE		A	B	C	D	L	dO	P	UPPER FLANGE			ANSI 150		DIN PN10	
in	DN								K	E	z-d	D1	n-d1	D1	n-d1
2	50	161	80	42	52.6	32	14.3	11	90	70	4-9	120.5	4-19	125	4-18
2-1/2	65	175	89	44.7	64.5	32	14.3	11	90	70	4-9	139.5	4-19	145	4-18
3	80	181	95	45.2	78.8	32	14.3	11	90	70	4-9	152.5	4-19	160	4-18
4	100	200	114	52.1	104	32	15.77	11	90	70	4-9	190.5	8-19	180	8-18
5	125	213	127	54.4	123.3	32	18.92	14	90	70	4-9	216	8-22	210	8-18
6	150	226	139	55.8	155.6	32	18.92	14	90	70	4-9	241.5	8-22	240	8-23
8	200	260	175	60.6	202.5	45	22.1	17	125	102	4-12	298.5	8-22	295	8-23
10	250	292	203	65.6	250.5	45	28.45	22	125	102	4-12	362	12-25	350	12-23
12	300	337	242	76.9	301.6	45	31.6	22	125	102	4-12	432	12-25	400	12-23
14	350	368	267	76.5	333.3	45	31.6	22	125	102	4-12	476	12-29	460	16-23
16	400	400	309	86.5	389.6	51.2	38	24	175	140	4-18	540	16-29	515	16-27
18	450	422	328	105.6	440.5	51.2	42.86	27	175	140	4-18	578	16-32	565	20-27
20	500	480	361	131.8	491.6	64.2	45.72	32	175	140	4-18	635	20-32	620	20-27
24	600	562	459	152	592.5	70.2	53.98	36	210	165	4-23	749.5	20-35	725	20-30



• CONCENTRIC BUTTERFLY VALVE



- Water works and water resource project
- Environment protection
- Public facilities
- Power and public utilities
- Building industry
- Petroleum, chemical
- Steel, metallurgy
- Paper making industry
- Foods, Beverage



Butterfly valve as used as shutting-off or throttling unit for petroleum processing, chemicals, food, medicine, textile, paper making, hydroelectricity engineering as well as light industry, etc. it can be installed in any selected position.

Type: Wafer
 Face to face: API609, BS5155, DIN3202,
 Flange: ISO5752
 Mounting Flange: DIN, BS, UNI, ISO, ANSI, AS, JIS
 ISO5211

Working Pressure: PN10 (150PSI)
 Application: Water works, Public facilities,
 Building Industry, Petroleum,
 Chemical, Steel, Metallurgy, Paper
 Making Industry, Foods, Beverage

Retaining system

The shaft is retained in the body with a retaining ring, a thrust washer and two C-rings, providing a "blow-out proof" shaft assembly. The retaining ring may be easily removed with a standard hand tool on field disassembly.

Shaft

One-piece through shaft ensures dependability and positive disc positioning.

Bushing (4-5)

Shaft bushings reduce torque and isolate the shaft from the valves body, preventing seizure of the shaft due to corrosion in the shaft journal.

Seat/Body

The tongue-and-groove seat to body retention method makes field replacement simple and fast. The resilient seat features lower torque and eliminates the need for flange gaskets.

Disc and shaft Connection

The spline or square connection eliminates shaft retention components being exposed to the line media, Maximum flow is achieved

Mounting Flange

ISO5211 mounting flange accommodates direct mounting of all types of actuators, including: handle, gear operator, electric and pneumatic.

O-Ring (1-2)

Shaft: seal provides further assurance against stem leakage.

Hub Seal

Smooth finished disc flats mate with seat flats to give a highly efficient primary seal that prevents leakage into the shaft area.

Disc

Precision profiles provides bubble-tight shut-off, assures minimum torque and longer seat life.





- Type:
Wafer
- Face to Face:
API609,BS5155,DIN3202, ISO5752
- Flange:
DIN,BS,UNI,ISO,ANSI, AS,JIS
- Mounting Flange:
ISO5211

- Working Pressure:
PN16(200PSI)
- Application:
Water works, Public facilities, Building Industry, Petroleum, Chemical, Steel, Metallurgy, Paper Making Industry, Foods, Beverage



Wafer Butterfly Valve (Four Holes With Tongue-And-Groove Seat)

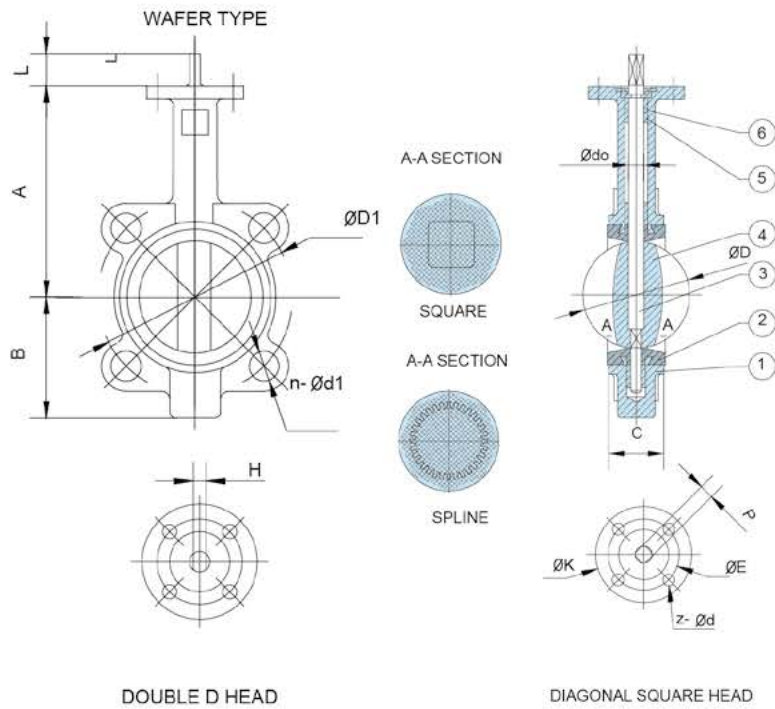

STANDARD MATERIALS OF MAIN PARTS

NO.	PART	MATERIAL
1	Body	Cast Iron, Ductile Iron, Carbon Steel, Stainless Steel
2	Seat	NBR, EPDM, Viton, Neoprene, Hypalon, Silicon
3	Shaft	Stainless Steel 416, 316.304
4	Disc	Ductile Iron+Ni (Nylon/Epoxy), CF8, CF8M, Bronze
5	Bushing	PTFE
6	O Ring	NBR,EPDM

DIMENSIONS

SIZE		A	B	C	D	L	d0	P	H	UPPER FLANGE			ANSI 150		DIN PN10	
in	DN									K	E	z-d	D1	n-d1	D1	n-d1
2	50	161	80	42.4	56	32	14.3/12.6	11/9	10	90	70	4-9	120.5	4-19	125	4-18
2-1/2	65	175	89	45.8	67.87	32	14.3/12.6	11/9	10	90	70	4-9	139.5	4-19	145	4-18
3	80	181	95	45.8	80.5	32	14.3/12.6	11/9	10	90	70	4-9	152.5	4-19	160	4-18
4	100	200	114	52	106.1	32	15.77	11	12	90	70	4-9	190.5	8-19	180	8-18
5	125	213	127	55	131	32	18.92	14	14	90	70	4-9	216	8-22	210	8-18
6	150	226	139	55	153.3	32	18.92	14	14	90	70	4-9	241.5	8-22	240	8-23
8	200	260	175	61	204.8	45	22.1	17	17	125	102	4-12	298.5	8-22	295	8-23
10	250	292	203	67.2	255.4	45	28.45	22	22	125	102	4-12	362	12-25	350	12-23
12	300	337	242	77	306.6	45	31.6	22	24	125	102	4-12	432	12-25	400	12-23

NOTE: (1) The maximum working pressure is 1.0 MPa (150PSI) .

Wafer Butterfly Valve (Two Holes With Tongue-And-Groove Seat)

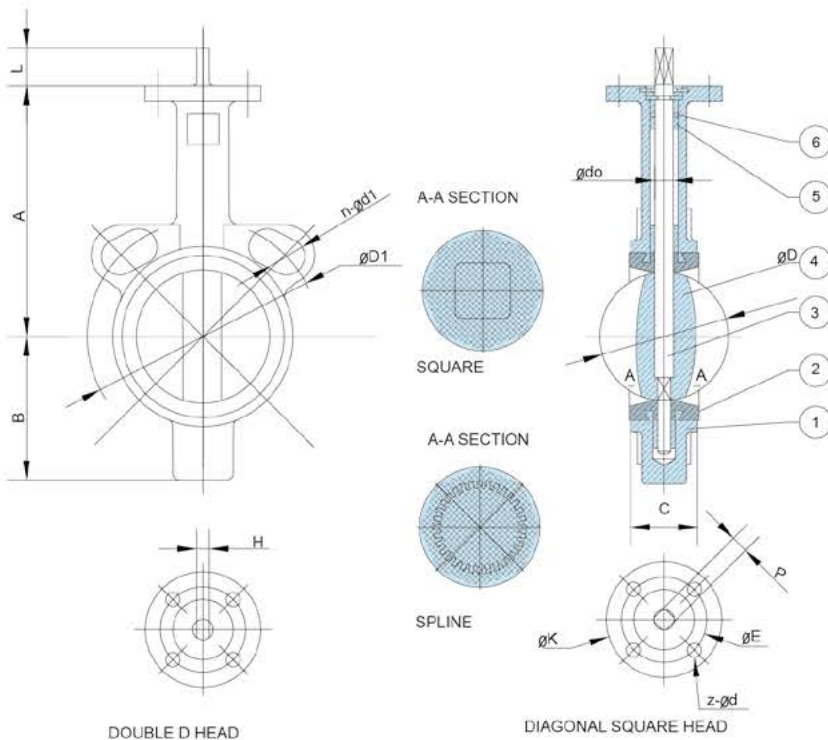

- Type:
Wafer
- Face to Face:
API609,BS5155,DIN3202, ISO5752
- Flange:
DIN,BS,UNI,ISO,ANSI, AS,JIS
- Mounting Flange:
ISO5211

- Working Pressure:
PN16(200PSI)
- Application:
Water works, Public facilities, Building Industry, Petroleum, Chemical, Steel, Metallurgy, Paper Making Industry, Foods, Beverage.

STANDARD MATERIALS OF MAIN PARTS

NO.	PART	MATERIALS
1	Body	Cast iron, Ductile iron, Carbon steel, Stainless Steel
2	seat	NBR, EPDM, Viton, Neoprene, Hypalon, Silicon
3	Shaft	Stainless Steel 416, 316, 304
4	Disc	Ductile iron+Ni(Nylon/Epoxy), CF8, CF8M, Bronze
5	Bushing	PTFE
6	O Ring	NBR, EPDM

DIMENSIONS

SIZE	A	B	C	D	L	d0	P	H	UPPER FLANGE			ANSI150		DIN PN10/16		JIS 10K		
									K	E	Z-d	D1	n-d1	D1	n-d1	D1	n-d1	
2	50	161	80	42.4	56	32	14.3/12.6	11/9	10	90	70	4-9	120.5	4-19	125	4-18	120	4-19
2-1/2	65	175	89	45.8	67.87	32	14.3/12.6	11/9	10	90	70	4-9	139.5	4-19	145	4-18	140	4-19
3	80	181	95	45.8	80.5	32	14.3/12.6	11/9	10	90	70	4-9	152.5	4-19	160	4/8-18	150	8-19
4	100	200	114	52	106.1	32	15.77	11	12	90	70	4-9	190.5	8-19	180	8-18	175	8-19
5	125	213	127	55	131	32	18.92	14	14	90	70	4-9	216	8-22	210	8-18	210	8-23
6	150	226	139	55	153.3	32	18.92	14	14	90	70	4-9	241.5	8-22	240	8-23	240	8-23
8	200	260	175	61	204.8	45	22.1	17	17	125	102	4-12	298.5	8-22	295	8/12-23	290	12-23
10	250	292	203	67.2	255.4	45	28.45	22	22	125	102	4-12	362	12-25	350/355	12-23/27	355	12-25
12	300	337	242	77	306.6	45	31.6	22	22	125	102	4-12	432	12-25	400/410	12-23/27	400	16-25





- Nominal Diameter: DN40-DN800mm
- Nominal Pressure: PN1.0-PN1.6MPa
- Suitable Medium: Various
Corrosiveness Medium
- Suitable Temperature: +10°C-150°C



PTFE Coated Butterfly Valve (Wafer Type)

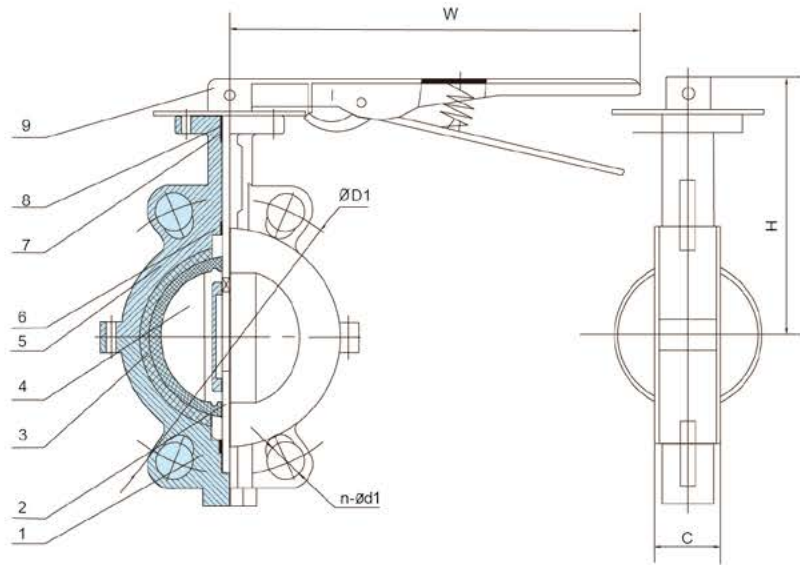

NOMINAL PRESSURE	1.0	MPa
SHELL TEST PRESSURE	1.5	
SEAL TEST PRESSURE	1.1	

STANDARD MATERIALS OF MAIN PARTS

ITEM	PART NAME	MA-	STANDARD
1	Lower Valve Body	Wcb	Cf8m
2	Stem	SS416	SS316
3	Seat	Ptfe	Ptfe
4	Disc	Wcb+Ptfe	Cf8m+Ptfe
5	Upper Valve Body	Wcb	CF8M
6	Bushing	Ptfe	Bronze
7	O Ring	Viton	Viton
8	Bushing	Ptfe	Bronze
9	Handle		

DIMENSIONS

SIZE		C	H	W	ANSI 150		DIN PN10/16	
IN	DN				D1	n-d1	D1	n-d1
1-1/2	40	40	150	270	98.5	4-15	110	4-18
2	50	43	167	270	120.5	4-19	125	4-18
2-1/2	65	46	170	270	139.5	4-19	145	4-18
3	80	46	170	270	152.5	4-19	160	4(4/8)-18
4	100	52	181	270	190.5	4(8)-19	180	4(8)-18
5	125	56	205	270	216	4(8)-22	210	4(8)-18
6	150	56	219	270	241.5	4(8)-22	240	4(8)-23
8	200	60	268	360	298.5	4(8)-22	295	4(8/12)-23
10	250	68	284	500	362	4(12)-25	350/355	4(12)-23/27
12	300	78	337	500	432	4(12)-25	400/410	4(12)-23/27

• CONCENTRIC BUTTERFLY VALVE



- Water works and water resource project
- Environment protection
- Public facilities
- Power and public utilities
- Building industry
- Petroleum, chemical
- Steel, metallurgy
- Paper making industry
- Foods, Beverage

Butterfly valve as used as shutting-off or throttling unit for petroleum processing, chemicals, food, medicine, textile, paper making, hydroelectricity engineering as well as light industry, etc. it can be installed in any selected position.

Type: Lugged
 Face to face: API609, BS5155, DIN3202, ISO5752
 Flange: DIN, BS, UNI, ISO, ANSI, AS, JIS
 Mounting Flange: ISO5211

Working Pressure: DN40-300:PN16 (200PSI)
 DN350&above: PN10 (150PSI)
 Application: Water works, Public facilities, Building Industry, Petroleum, Chemical, Steel, Metallurgy, Paper Making Industry, Foods, Beverage

Weather Seal

Top bushing keep dust and moisture from entering the upper shaft journal.

Shaft

One-piece through shaft ensures dependability and positive disc positioning.

Bushing(4-5)

Shaft bushings reduce torque and isolate the shaft from the valves body, preventing seizure of the shaft due to corrosion in the shaft journal.

Seat Face

Seat to flange seal eliminates the need for flange gaskets.

Seat

Phonetic-backed seat is non-collapsible, stretch resistant, blow out proof, and field replaceable.

Mounting Flange

ISO5211 mounting flange accommodates direct mounting of all types of actuators, including: handle, gear operator, electric and pneumatic.

O-Ring(1-2)

Shaft seal provides further assurance against stem leakage.

Flats Seal

Smooth finished disc flats mate with seat to give a highly efficient primary seal that prevents leakage into the shaft area.

Taper Pin (1-3)

Precision taper pin ensure positive, vibration proof, shaft to disc connection. Field replaceable.

Disc

Precision profiles provides bubble-tight shut-off, assures minimum torque and longer seat life.



Lug Butterfly Valve (Through Shaft Without Pin)

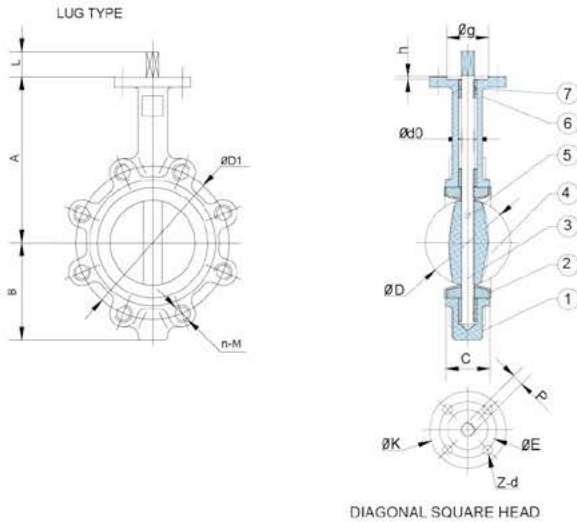

STANDARD MATERIALS OF MAIN PARTS

NO.	PART	MATERIAL
1	Body	Cast Iron, Ductile Iron, Carbon Steel, Stainless Steel
2	Seat	NBR, EPDM, Viton, Neoprene, Hypalon, Silicon
3	Shaft	Stainless Steel 416,316,304
4	Disc	Ductile Iron+Ni, CF8, CF8M, Bronze
5	Pin	Stainless Steel
6	Bushing	PTFE, Bronze
7	O Ring	NBR, EPDM

DIMENSIONS

SIZE	in	DN	A	B	C	D	L	d0	P	H	KEY b×1	UPPER FLANGE					ANSI 150		DIN PN10/16	
												K	E	z-d	g	h	D1	n-M	D1	n-M
1-1/2	40	145	75	33	42.4	32	12.6	9	10	3×16	77	50	4-7	35	3	98.5	4-1/2"	110	4-M16	
2	50	161	80	42	52.6	32	12.6	9	10	3×16	77	50	4-7	35	3	120.5	4-5/8"	125	4-M16	
2-1/2	65	175	89	44.7	64.5	32	12.6	9	10	3×16	77	50	4-7	35	3	139.5	4-5/8"	145	4-M16	
3	80	181	95	45.2	78.8	32	12.6	9	10	3×16	77	50	4-7	35	3	152.5	4-5/8"	160	4/8-M16	
4	100	200	114	52.1	104	32	15.77	11	12	5×19	90	70	4-9	55	3	190.5	8-5/8"	180	8-M16	
5	125	213	127	54.4	123.3	32	18.92	14	14	5×19	90	70	4-9	55	3	216	8-3/4"	210	8-M16	
6	150	226	139	55.8	155.6	32	18.92	14	14	5×19	90	70	4-9	55	3	241.5	8-3/4"	240	8-M20	
8	200	260	175	60.6	202.5	45	22.1	17	17	5×19	125	102	4-12	70	35	298.5	8-3/4"	295	8/12-M20	
10	250	292	203	65.6	250.5	45	28.45	22	22	8×28	125	102	4-12	70	35	362	12-7/8"	350/355	12-M20/M24	
12	300	337	242	76.9	301.6	45	31.6	22	24	8×28	125	102	4-12	70	35	432	12-7/8"	400/410	12-M20/M24	
14	350	368	267	76.5	333.3	45	31.6	22	24	8×28	125	102	4-12	70	35	476	12-1"	460/470	16-M20/M24	
16	400	400	309	86.5	389.6	51.2	33.15	24	24	8×28	175	140	4-18	100	4	540	16-1"	515/525	16-M24/M27	
18	450	422	328	105.6	440.5	51.2	38	27	27	8×28	175	140	4-18	100	4	578	16-11/8"	565/585	20-M24/M27	
20	500	480	361	131.8	491.6	64.2	41.15	32	32	8×28	175	140	4-18	100	4	635	20-11/8"	620/650	20-M24/M30	
24	600	562	459	152	592.5	70.2	50.65	36	36	8×28	210	165	4-23	130	5	749.5	20-11/4"	725/770	20-M27/M33	



- Type:
Lugged
- Face to Face:
API609,BS5155,DIN3202, ISO5752
- Flange:
DIN,BS,UNI,ISO,ANSI, AS,JIS
- Mounting Flange:
ISO5211

- Working Pressure:
PN16(200PSI)
- Application:
Water works, Public facilities, Building Industry, Petroleum, Chemical, Steel, Metallurgy, Paper Making Industry, Foods, Beverage





- Type:
Lugged
- Face to Face:
API609, BS5155, DIN3202, ISO5752
- Flange:
DIN, BS, UNI, ISO, ANSI, AS, JIS
- Mounting Flange:
ISO5211

- Working Pressure:
PN16(200PSI)
- Application:
Water works, Public facilities, Building Industry, Petroleum, Chemical, Steel, Metallurgy, Paper Making Industry, Foods, Beverage



Lug Butterfly Valve (Half Shaft Without Pin)

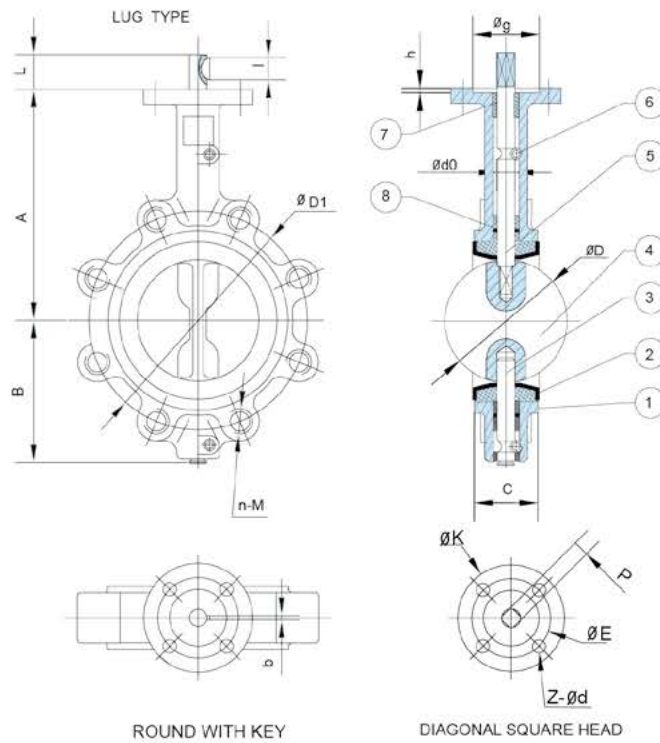

STANDARD MATERIALS OF MAIN PARTS

NO.	PART	MATERIAL
1	Body	Cast Iron, Ductile Iron, Carbon Steel, Stainless Steel
2	Seat	NBR, EPDM, PTFE, Viton, Neoprene, Hypalon, Silicon
3	Lower Shaft	Stainless Steel 416, 316, 304
4	Disc	Ductile Iron+Ni (Nylon/Epoxy), CF8, CF8+PTFE(PFA), CF8M, CF8M+PTFE(PFA), Bronze
5	Upper Shaft	Stainless Steel 416, 316, 304
6	Locating Pin	Carbon Steel
7	Bushing	PTFE
8	O Ring	NBR, EPDM

DIMENSIONS

SIZE	DN	A	B	C	D	L	d0	P	KEY b×1	UPPER FLANGE				ANSI 150		DIN PN10/PN16		
										K	E	z-d	g	h	D1	n-M	D1	n-M
2	50	161	80	42	52.9	32	12.6	9	3×16	77	50	4-7	35	3	120.5	4-5/8"	125	4-M16
2-1/2	65	175	89	44.7	64.5	32	12.6	9	3×16	77	50	4-7	35	3	139.5	4-5/8"	145	4-M16
3	80	181	95	45.2	78.8	32	12.6	9	3×16	77	50	4-7	35	3	152.5	4-5/8"	160	4/8-M16
4	100	200	114	52.1	104	32	15.77	11	5×19	90	70	4-9	55	3	190.5	8-5/8"	180	8-M16
5	125	213	127	54.4	123.3	32	18.92	14	5×19	90	70	4-9	55	3	216	8-3/4"	210	8-M16
6	150	226	139	55.8	155.6	32	18.92	14	5×19	90	70	4-9	55	3	241.5	8-3/4"	240	8-M20
8	200	260	175	60.6	202.5	45	22.1	17	5×19	125	102	4-12	70	3.5	298.5	8-3/4"	295	8/12-M20
10	250	292	203	65.6	250.5	45	28.45	22	8×19	125	102	4-12	70	3.5	362	12-7/8"	350/355	12-M20/M24
12	300	337	242	76.9	301.6	45	31.6	22	8×19	125	102	4-12	70	3.5	432	12-7/8"	400/410	12-M20/M24

NOTE: (1) The maximum working pressure is 1.6 MPa (200PSI)

(2) For dead end use, the maximum working pressure is 0.8MPa (100PSI)

Lug Butterfly Valve (Through Shaft Without Pin)

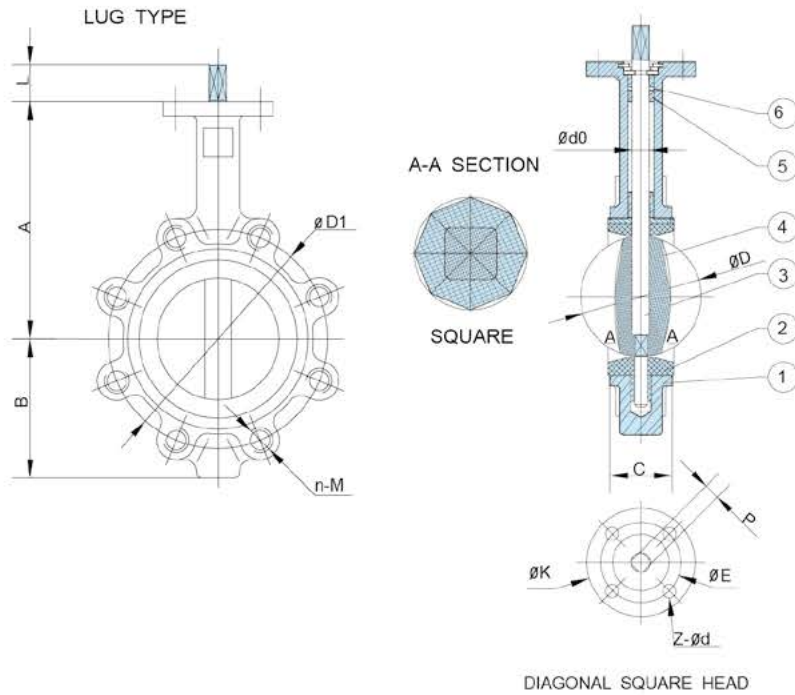

- Type:
Lugged
- Face to Face:
API609,BS5155,DIN3202, ISO5752
- Flange:
DIN,BS,UNI,ISO,ANSI, AS,JIS
- Mounting Flange:
ISO5211

- Working Pressure:
PN16(200PSI)
- Application:
Water works, Public facilities, Building Industry, Petroleum, Chemical, Steel, Metallurgy, Paper Making Industry, Foods, Beverage

STANDARD MATERIALS OF MAIN PARTS

NO.	PART	MATERIAL
1	Body	Cast Iron, Ductile Iron, Stainless Steel
2	Seat	EPDM,NBR,Viton
3	Shaft	Stainless Steel 416,316,304
4	Disc	DI+NI,CF8,CF8M
5	Bushing	PTFE
6	O Ring	NBR

DIMENSIONS

SIZE		A	B	C	D	L	d0	P	UPPER FLANGE			ANSI 150		DIN PN10	
in	DN								K	E	z-d	D1	n-M	D1	n-M
2	50	161	80	42	52.6	32	14.3	11	90	70	4-9	120.5	4-5/8"	125	4-M16
2-1/2	65	175	89	44.7	64.5	32	14.3	11	90	70	4-9	139.5	4-5/8"	145	4-M16
3	80	181	95	45.2	78.8	32	14.3	11	90	70	4-9	152.5	4-5/8"	160	4-M16
4	100	200	114	52.1	104	32	15.77	11	90	70	4-9	190.5	8-5/8"	180	8-M16
5	125	213	127	54.4	123.3	32	18.92	14	90	70	4-9	216	8-3/4"	210	8-M16
6	150	226	139	55.8	155.6	32	18.92	14	90	70	4-9	241.5	8-3/4"	240	8-M20
8	200	260	175	60.6	202.5	45	22.1	17	125	102	4-12	298.5	8-3/4"	295	8-M20
10	250	292	203	65.6	250.5	45	28.45	22	125	102	4-12	362	12-7/8"	350	12-M20
12	300	337	242	76.9	301.6	45	31.6	22	125	102	4-12	432	12-7/8"	400	12-M20
14	350	368	267	76.5	333.3	45	31.6	22	125	102	4-12	476	12-1"	460	16-M20
16	400	400	309	86.5	389.6	51.2	38	24	175	140	4-18	540	16-1"	515	16-M24
18	450	422	328	105.6	440.5	51.2	42.86	27	175	140	4-18	578	16-11/8"	565	20-M24
20	500	480	361	131.8	491.6	64.2	45.72	32	175	140	4-18	635	16-11/8"	620	20-M24
24	600	562	459	152	592.5	70.2	53.98	36	210	165	4-23	749.5	20-11/4"	725	20-M27





Lug Butterfly Valve (Through Shaft Without Pin)

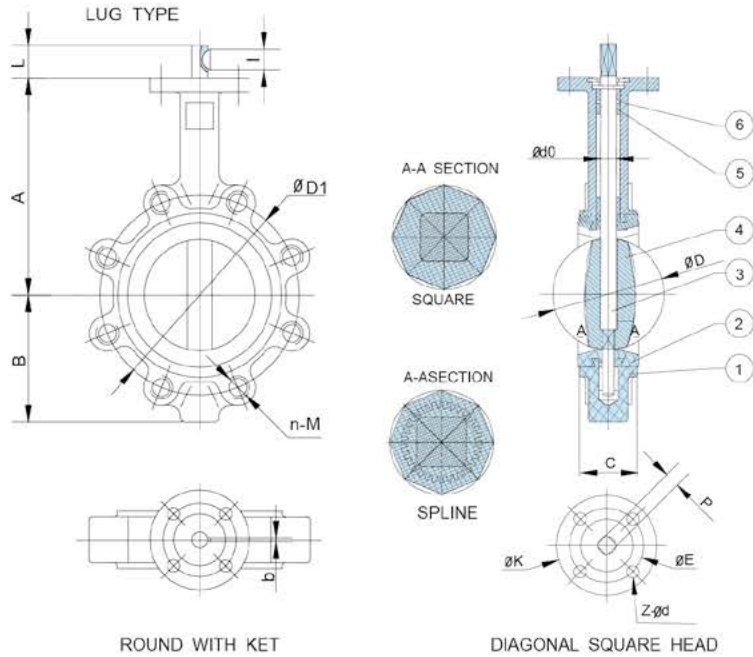

- Type:
Lugged
 - Face to Face:
API609,BS5155,DIN3202, ISO5752
 - Flange:
DIN,BS,UNI,ISO,ANSI, AS,JIS
 - Mounting Flange:
ISO5211
-
- Working Pressure:
PN16(200PSI)
 - Application:
Water works, Public facilities, Building Industry, Petroleum, Chemical, Steel, Metallurgy, Paper Making Industry, Foods, Beverage

STANDARD MATERIALS OF MAIN PARTS

NO.	PART	MATERIAL
1	Body	Cast Iron, Ductile Iron, Carbon Steel, Stainless Steel
2	Seat	NBR, EPDM, Viton, Neoprene, Hypalon, Silicon
3	Shaft	Stainless Steel 416, 316,304
4	Disc	Ductile Iron+Ni (Nylon/Epoxy), CF8, CF8M, Bronze
5	Bushing	PTFE
6	O Ring	NBR,EPDM

DIMENSIONS

SIZE		A	B	C	D	L	d0	P	KEY bXl	UPPER FLANGE			ANSI 150		DNP10	
in	DN									K	E	z-d	D1	n-M	D1	n-M
2	50	161	80	42.4	56	32	14.3/12.6	11/9	3×16	90	70	4-9	120.5	4-5/8"	125	4-M16
2-1/2	65	175	89	45.8	67.87	32	14.3/12.6	11/9	3×16	90	70	4-9	139.5	4-5/8"	145	4-M16
3	80	181	95	45.8	80.5	32	14.3/12.6	11/9	3×16	90	70	4-9	152.5	4-5/8"	160	4-M16
4	100	200	114	52	106.1	32	15.77	11	5×19	90	70	4-9	190.5	8-5/8"	180	8-M16
5	125	213	127	55	131	32	18.92	14	5×19	90	70	4-9	216	8-3/4"	210	8-M16
6	150	226	139	55	153.3	32	18.92	14	5×19	90	70	4-9	241.5	8-3/4"	240	8-M20
8	200	260	175	61	204.8	45	22.1	17	5×19	125	102	4-12	298.5	8-3/4"	295	8-M20
10	250	292	203	67.2	255.4	45	28.45	22	8×28	125	102	4-12	362	12-7/8"	350	12-M20
12	300	337	242	77	306.6	45	31.6	22	8×28	125	102	4-12	432	12-7/8"	400	12-M20

NOTE: (1) The maximum working pressure is 1.0 MPa (150PSI).
 (2) For dead end use, the maximum working pressure is 0.5MPa (75PSI).



PTFE Coated Butterfly Valve (Lug Type)

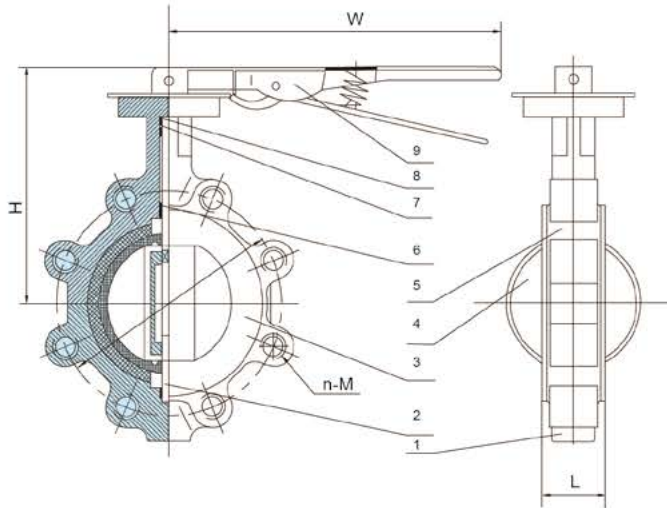

NOMINAL PRESSURE	1.0	MPa
SHELL TEST PRESSURE	1.5	
SEAL TEST PRESSURE	1.1	

- Nominal Diameter: DN40-DN800mm
- Nominal Pressure: PN1.0-PN1.6MPa
- Suitable Medium: Various
Corrosiveness Medium
- Suitable Temperature: +10°C-150°C

STANDARD MATERIALS OF MAIN PARTS

ITEM	PART NAME	MATERIAL
1	LOWER VALVE BODY	WCB CF8M
2	Stem	SS416 SS316
3	Seat	PTFE PTFE
4	Disc	WCB+PTFE CF8M+PTFE
5	Upper Valve Body	WCB CF8M
6	Bushing	PTFE Bronze
7	O Ring	Viton Viton
8	Bushing	PTFE Bronze
9	Handle	

DIMENSIONS AND WEIGHTS

SIZE		H	L	W	ANSI 150		DIN PN10/16	
IN	DN				D1	n-M	D1	n-M
1-1/2	40	150	40	270	98.5	4-1/2"	110	4-M16
2	50	167	43	270	120.5	4-5/8"	125	4-M16
2-1/2	65	170	46	270	139.5	4-5/8"	145	4-M16
3	80	170	46	270	152.5	4-5/8"	160	4/8-M16
4	100	181	52	270	190.5	8-5/8"	180	8-M16
5	125	205	56	270	216	8-3/4"	210	8-M16
6	150	219	56	270	241.5	8-3/4"	240	8-M20
8	200	268	60	360	298.5	8-3/4"	295	8/12-M20
10	250	284	68	500	362	12-7/8"	350/355	12-M20/M24
12	300	337	78	500	432	12-7/8"	400/410	12-M20/M24





- Type:
Flange
- Face to Face:
BS5155, ISO5752
- Flange:
DIN, BS, UNI, ISO, ANSI, AS, JIS
- Mounting Flange:
ISO5211

- Working Pressure:
PN16(200PSI)
- Application:
Water works, Public facilities, Building Industry, Petroleum, Chemical, Steel, Metallurgy, Paper Making Industry, Foods, Beverage



Concentric Flanged Butterfly Valve

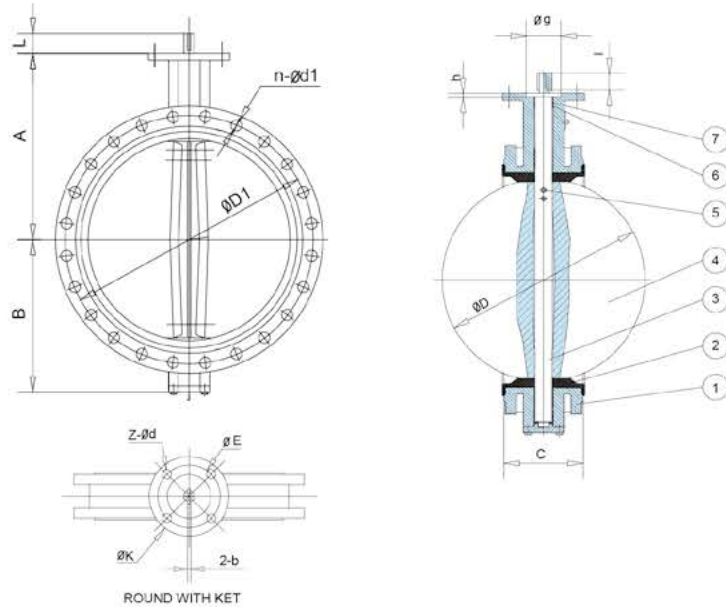

STANDARD MATERIALS OF MAIN PARTS

NO.	PART	MATERIAL
1	Body	Cast Iron, Ductile Iron
2	Seat	NBR, EPDM
3	Shaft	Stainless Steel 416, 316, 304
4	Disc	Ductile Iron+Ni, CF8, CF8M, Bronze
5	Pin	Stainless Steel
6	Bushing	PTFE, Bronze
7	O Ring	NBR, EPDM

DIMENSIONS

SIZE		A	B	C	D	L	KEY b×1	UPPER FLANGE				ANSI 150		DIN PN10/PN16		
in	DN							K	E	z-d	g	h	D1	n-d1	D1	n-d1
2	50	120	83	108	52.9	32	3×16	70	50	4-7	35	3	120.5	4-19	125	4-18
2 1/2	65	130	93	112	64.5	32	3×16	70	50	4-7	35	3	139.5	4-19	145	4-18
3	80	145	100	114	78.8	32	3×16	70	50	4-7	35	3	152.5	4-19	160	4/8-18
4	100	155	114	127	104	32	5×19	90	70	4-9	55	3	190.5	8-19	180	8-18
5	125	170	125	140	123.3	32	5×19	90	70	4-9	55	3	216	8-22	210	8-18
6	150	190	143	140	155.6	32	5×19	90	70	4-9	55	3	241.5	8-22	240	8-23
8	200	205	170	152	202.5	45	5×19	125	102	4-12	70	3.5	298.5	8-22	295	8/12-23
10	250	235	198	165	250.5	45	8×28	125	102	4-12	70	3.5	362	12-25	350/355	12-23/27
12	300	280	223	178	301.6	45	8×28	140	102	4-12	70	3.5	432	12-25	400/410	12-23/27
14	350	310	279	190	333.3	45	8×28	140	102	4-12	70	3.5	476	12-29	460/470	16-23/27
16	400	340	300	216	389.6	51.2/72	10×50	175	140	4-18	100	4	540	16-29	515/525	16-27/30
18	450	375	345	222	440.5	51.2/72	10×50	175	140	4-18	100	4	578	16-32	565/585	20-27/30
20	500	430	355	229	491.6	52.7/75	10×50	175	140	4-18	100	4	635	20-32	620/650	20-27/33
24	600	500	410	267	592.5	70.2/80	2-16×60	210	165	4-23	130	5	749.5	20-35	725/770	20-30/36
28	700	560	478	292	695	66/82	2-18×63	300	254	8-18	200	5.5	863.5	28-35	840	24-30/36
32	800	620	529	318	794.7	66/82	2-18×63	300	254	8-18	200	5.5	978	28-41	950	24-33/39
36	900	665	584	330	864.7	118	2-20×100	300	254	8-18	200	5.5	1086	32-41	1050	28-33/39
40	1000	735	657	410	965	141	2-22×140	300	254	8-18	200	5.5	1200	36-41	1160/1170	28-36/42

NOTE: (1) The maximum working pressure is 1.6 Mpa(200PSI) for 11/2"-12", 1.0MPa (150PSI) for 14"and larger.
 (2) 14"-24" maximum working pressure of 1.6Mpa(200PSI) can be supplied as per specified order requirement.

Grooved End Butterfly Valve

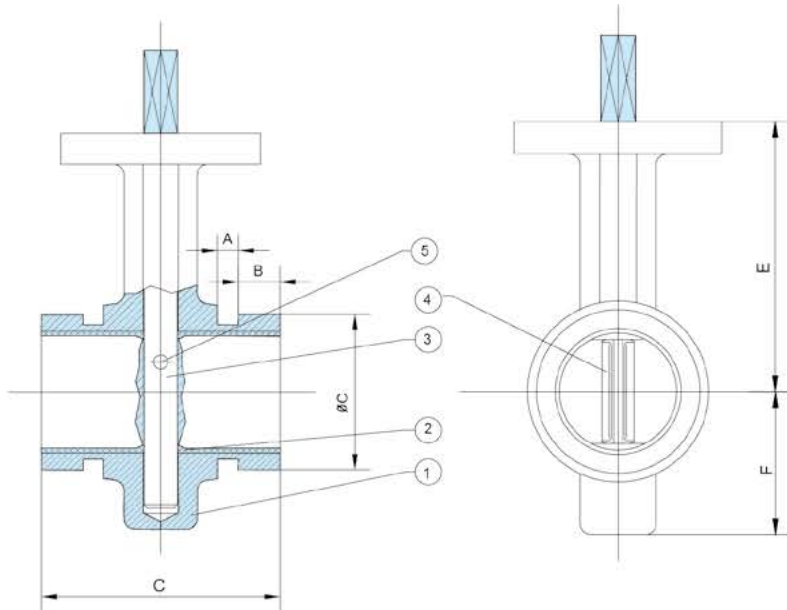

- Type:
Grooved
- Flange:
DIN, BS, UNI, ISO, ANSI
- Mounting Flange:
ISO5211

- Working Pressure:
PN16(200PSI)
- Application:
Water works, Public facilities, Building Industry, Petroleum, Chemical, Steel, Metallurgy, Paper Making Industry, Foods, Beverage

STANDARD MATERIALS OF MAIN PARTS

NO.	PART	MATERIAL
1	Body	Cast Iron, Ductile Iron
2	Seat	NBR, EPDM
3	Shaft	Stainless Steel 416, 316, 304
4	Disc	Ductile Iron+Ni, CF8, CF8M
5	Pin	Stainless Steel

DIMENSIONS

SIZE		A	B	C	L	E	F
in	DN						
2	50	8	16	60	92	100	53
2-1/2	65	8	16	76	102	108	61
3	80	8	16	89	102	114	68
4	100	10	16	114	116	136	85
5	125	10	16	141	125	162	99
6	150	10	16	165	125	174	111
8	200	11	19	219	138	230	145



Resilient Seated Eccentric Flanged Butterfly Valve



- Type:
Flanged
- Face to Face:
API609,BS5155,DIN3202, ISO5752
- Flange:
DIN,BS,UNI,ISO,ANSI, AS,JIS
- Mounting Flange:
ISO5211

- Working Pressure:
PN10
- Application:
Water works, Public facilities, Building Industry, Petroleum, Chemical, Steel, Metallurgy, Paper Making Industry, Foods, Beverage

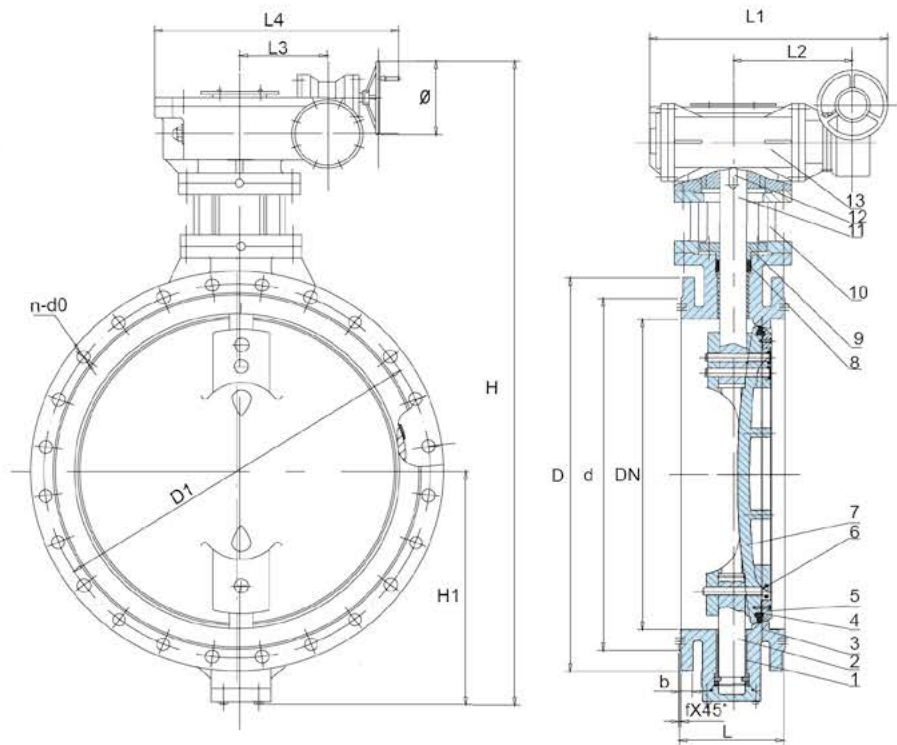

Resilient Seated Eccentric Flanged Butterfly Valve

STANDARD MATERIALS OF MAIN PARTS

NO.	PART	MATERIAL
1	Bushing	Bronze/PTFE
2	Bottom Shaft	Stainless Steel 420
3	Body	Cast Iron/Ductile Iron
4	Disc Sealing Ring	NBR
5	Retainer	Carbon Steel
6	Taper Pin	Stainless Steel 420
7	Disc	Ductile Iron
8	Sealing Ring	NBR
9	Stuffing Flange	Ductile Iron
10	Support	Ductile Iron
11	Top Shaft	Stainless Steel 420
12	Key	Carbon Steel
13	Actuator	Worm gear Actuator

DN	d	D1		D	H	H1	L			L1	L2	L3	L4	f	Φ	b	n-d0
		PN10					SHORT BODY	MIDDLE BODY	LONG BODY								PN10
DN100(4")	156	180	220	419	109	/	127	190	97	45	158	210	3	150	19	8-19	
DN150(6")	211	240	285	583	143	/	140	210	97	45	158	210	3	150	19	8-23	
DN200(8")	266	295	340	692	182	89	152	230	140	63	238	315	3	300	20	8-23	
DN250(10")	319	350	395	784	219	114	165	250	140	63	238	315	3	300	22	12-23	
DN300(12")	370	400	445	874	244	114	178	270	167	72	167	242	4	300	24.5	12-23	
DN350(14")	429	460	505	998	283	127	190	290	201	91	188	275	4	400	24.5	16-23	
DN400(16")	480	515	565	1062	312	140	216	310	201	91	188	275	4	400	24.5	16-28	

DN	d	D1		D	H	H1	L			L1	L2	L3	L4	f	Φ	b	n-d0
		PN10					SHORT BODY	MIDDLE BODY	LONG BODY								PN10
DN450(18")	530	565	615	1164	344	152	222	330	473	147	109	420	4	400	25.5	20-28	
DN500(20")	582	620	670	1226	381	152	229	350	473	147	109	420	4	400	26.5	20-28	
DN600(24")	682	725	780	1380	450	178	267	390	533	179	138	476	5	400	30	20-31	
DN700(28")	794	840	895	1585	535	229	292	430	533	179	138	476	5	400	32.5	24-31	
DN800(32")	901	950	1015	1750	590	241	318	470	655	217	170	577	5	500	35	24-34	
DN900(36")	1001	1050	1115	1840	643	241	330	510	655	217	170	577	5	500	37.5	28-34	
DN1000(40")	1112	1160	1230	1999	722	300	410	550	655	217	170	577	5	500	40	28-37	
DN1200(48")	1328	1380	1455	2351	840	350	470	630	748	262	202	664	5	500	45	32-40	



Metal Seated Eccentric Butterfly Valve (Wafer Type)

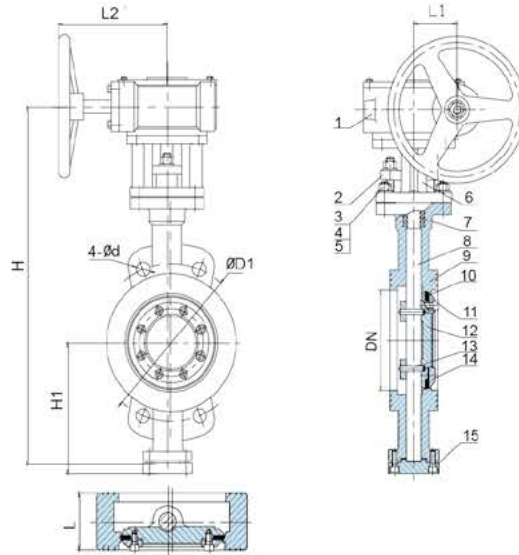

- Type:
Wafer
 - Flange:
DIN,BS,UNI,ISO,ANSI, AS,JIS
 - Mounting Flange:
ISO5211
-
- Working Pressure:
PN16(200PSI)
 - Application:
Water works, Public facilities, Building
Industry, Petroleum, Chemical, Steel,
Metallurgy, Paper Making Industry,
Foods, Beverage

STANDARD MATERIALS OF MAIN PARTS

NO.	PART	DIMENSIONS
1	Wormgear Actuator	Components
2	Packing Flange	Carbon Steel
3	Stud	Carbon Steel
4	Washer	Spring Steel
5	Bolt	Carbon Steel
6	Connecting Support	Carbon Steel
7	packing	Flexible Graphite
8	Stem	Stainless Steel 420
9	Body	Carbon Steel ,CF8 CF8M
10	Sealing Ring	SS316 + Flexible Graphite
11	Bolt	Carbon Steel
12	Disc	Carbon Steel ,CF8 CF8M
13	pin	Stainless Steel 420
14	Disc Flange	Carbon Steel
15	End Cover	Carbon Steel

DIMENSIONS

DN	L	H	H1	L1	L2	D1	4-Ød
DN50(2")	43	250	80	48	145	125	4-18
DN65(2.5")	46	265	95	48	145	145	4-18
DN80(3")	49	275	100	48	145	160	4-18
DN100(4")	56	400	125	48	145	180	4-18
DN125(5")	64	420	135	70	175	210	4-18
DN150(6")	70	480	172	70	175	240	4-22
DN200(8")	71	530	240	90	200	295	4-22
DN250(8")	76	640	265	90	200	350	4-22
DN300(12")	83	720	295	125	280	400	4-22
DN350(14")	92	770	330	125	280	460	4-22
DN400(16")	102	880	370	125	280	515	4-26
DN450(18")	114	930	395	130	280	565	4-26
DN500(20")	127	1000	430	130	280	620	4-26
DN600(24")	154	1130	490	175	365	725	4-30
DN700(28")	165	1270	545	175	365	840	4-30
DN800(32")	190	1560	615	225	440	950	4-33
DN900(36")	203	1700	700	225	440	1050	4-33
DN1000(40")	216	1865	715	290	490	1160	4-36



Metal Seated Eccentric Butterfly Valve (Flange Type)

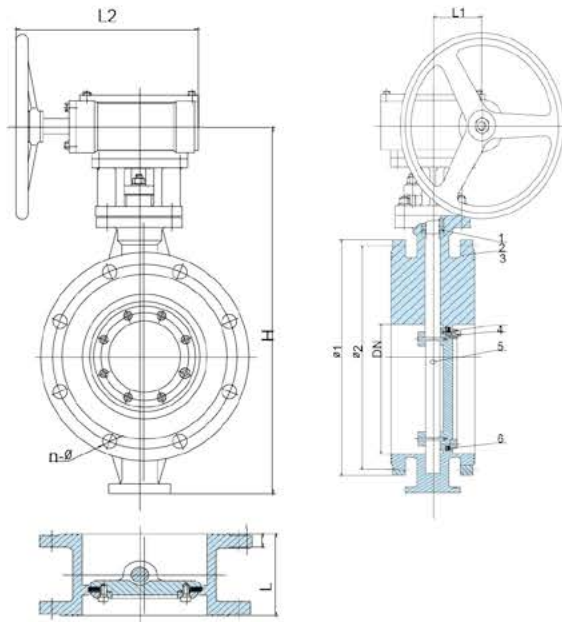

NO.	PART	MATERIALS
1	Packing	Graphite
2	Body	Carbon steel ,Stainless steel
3	Disc	Carbon steel,Stainless steel
4	Bolts	Carbon steel,Stainless steel
5	Shaft	Carbon steel,Stainless steel
6	Seat	PTFE, stainless steel

SIZE	DN	L	H	DIN PN10/16			L1	L2
				Φ1	Φ2	N-Φ		
DN50	Φ50	108	320	Φ165	Φ125	4-Φ18	40	130
DN65	Φ65	112	370	Φ185	Φ145	4-Φ18	40	130
DN80	Φ80	114	370	Φ200	Φ160	4/8-Φ18	40	130
DN100	Φ100	127	370	Φ220	Φ180	8-Φ18	48	145
DN125	Φ125	140	420	Φ250	Φ210	8-Φ18	70	175
DN150	Φ150	140	505	Φ285	Φ240	8-Φ22	70	175
DN200	Φ200	152	610	Φ340	Φ295	8/12-Φ22	90	200
DN250	Φ250	165	665	Φ395/Φ405	Φ350/Φ355	12-Φ23/Φ26	90	200
DN300	Φ300	178	755	Φ445/Φ460	Φ400/Φ410	12-Φ23/Φ26	125	280
DN350	Φ350	190	860	Φ505/Φ520	Φ460/Φ470	16-Φ23/Φ26	125	280
DN400	Φ400	216	890	Φ565/Φ580	Φ515/Φ525	16-Φ26/Φ30	125	280
DN500	Φ500	229	1040	Φ670/Φ715	Φ620/Φ650	20-Φ26/Φ33	130	280
DN600	Φ600	267	1285	Φ780/Φ840	Φ725/Φ770	20-Φ30/Φ36	175	365



- Type:
Flange
- Flange:
DIN,BS,UNI,ISO,ANSI, AS,JIS
- Mounting Flange:
ISO5211

- Working Pressure:
PN16(200PSI)
- Application:
Water works, Public facilities, Building
Industry, Petroleum, Chemical, Steel,
Metallurgy, Paper Making Industry,
Foods, Beverage



• GATE VALVE

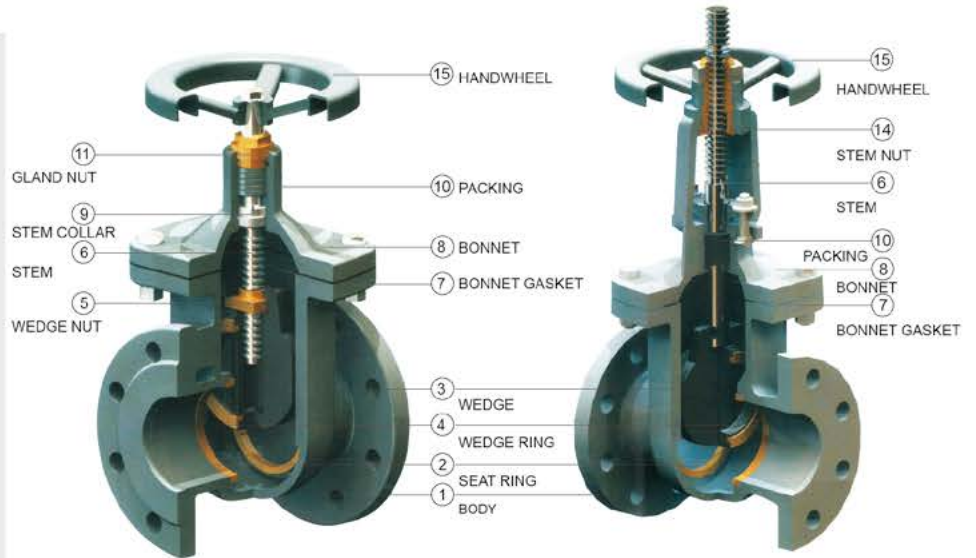

Top sealing

- 1. Reliable seal, long service life, easy to maintain, high temperature resistant and incorrodible.
- 2. Low open torque, turning freely, suitable for resilient seal gate valve
- 3. Low open torque, turning freely, easy to maintain
- 4. Reliable sea, long service life, easy to install and maintain

Body

Oval bore design to ensure good compression and deformation resist performance. Body surface with FEB coated to ensure good ageing resistance & weather resisting property.

Handwheel

Handwheel with tapered square hole, easy to install and fasten.

Seat

Embedded type seat, safety and integrated.

Gasket

Compound Graphite gasket, good performance and long service life.

Stem Nut

Cooper stem nut. Good anticorrosion performance.

Disc

Disc with guide groove to protect the sealing face, also to ensure on-off freely.

Bolt, Nut, Half Ring

Stem is oriented by half ring and double bolt&nuts to ensure the disc on-off freely.

Packing

Soft graphite, long service life, easy to sealing and maintain.

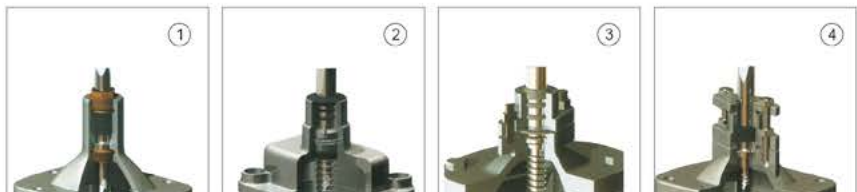

● **Application:**

The series of gate valve is specially designed to suit for transportation, distribution and extraction system in water, air, low pressure steam, gas and petroleum industry, not recommend for steam service.

● **Normal Features:**

1. Renewable Brass or Bronze Seat Ring.
2. Non-Asbestos Packing and Gasket.
3. Disc seat ring in all sizes are present into disc.
4. Big flow area, small flow resistance coefficient and good leak tightness in high pressure
5. Widely use field, good adaptability.
6. No direction demand, easy to install in pipe.
7. Good material washability.

● **Service conditons:**

Normal: temperature from -10 degree to 120 degree for Brass or Bronze seat

ITEM NO.	PART NAME	MATERIAL		SPECIFICATION
1	BODY	CAST IRON	GG25	ASTM A126B
		DUCTILE IRON	GGG50	ASTM A536
2	SEAT RING	BRASS	BRASS	ASTM B16
		BRONZE	BRONZE	ASTM B62
3	WEDGE	CAST IRON	GG25	ASTM A126B
		DUCTILE IRON	GGG50	ASTM A536
4	WEDGE RING	BRASS	BRASS	ASTM B16
		BRONZE	BRONZE	ASTM B62
5	WEDGE NUT	BRASS	BRASS	ASTM B16
6	STEM	STAINLESS/STEEL	20CR13	SS416
		BRASS	BRASS	ASTM B16
7	BONNET GASKET	GRAPHITE+STEEL	GRAPHITE+STEEL	GRAPHITE+STEEL
8	BONNET	CAST IRON	GG25	ASTM A126B
		DUCTILE IRON	GGG50	ASTM A536
9	STEM COLLAR	STAINLESS STEEL	20CR13	SS410
10	PACKING	GRAPHITE	GRAPHITE	GRAPHITE
11	GLAND NUT	BRASS	BRASS	ASTM B16
12	STUFFING BOX	CAST IRON	GG25	ASTM A126B
		DUCTILE IRON	GGG50	ASTM A536
13	GLAND FLOLLOWER	DUCTILE IRON	GGG50	ASTM A536
14	STEM NUT	BRASS	BRASS	ASTM B16
15	HANDWHEEL	DUCTILE IRON	GGG50	ASTM A536



Non-Rising Stem Solid Wedge Gate Valve (ANSI B16.10)

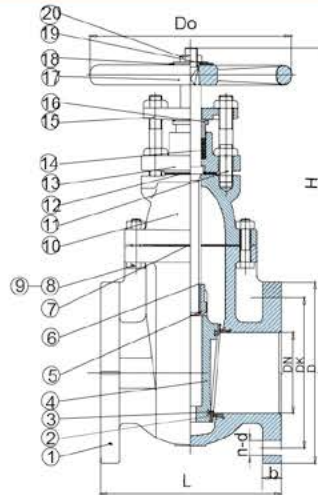

- Conforms to MSS SP-70
- Flanges drilled to ANSI B16.1(125LB)
- Face to Face dimensions conform to ANSI B16.10(125LB)
- Working pressure: 125S, 200WOG.
- Suitable media: water, oil, gas.
- Construction available in all iron.

DIMENSIONS IN INCHES AND MILLIMETRES

DN	L	Dk	D	b	n-d	Do	H
2"	178	121	152	15.9	4-19	178	289
2.5"	190.5	140	178	17.5	4-19	178	323
3"	203.2	152.5	190	19.1	4-19	200	338
4"	228.6	190.5	228.6	23.5	8-19	254	411
5"	254	215.9	254	23.8	8-22	300	503
6"	266.7	241.3	279.4	25.4	8-22	300	558
8"	292	298.5	343	28.6	8-22	348	650
10"	330	362	406	30.2	12-25	400	770
12"	356	432	483	31.8	12-25	457	861
14"	381	476	533	35	12-29	508	991
16"	406	540	597	36.6	16-29	558	1058
18"	432	578	635	39.7	16-32	610	1206
20"	457	635	699	42.9	20-32	640	1276
24"	508	749	813	47.6	20-35	762	1466
30"	610	914	984	54	28-35	813	1845
36"	711	1086	1168	60.3	32-42	813	2124



NO.	PART	MATERIAL	STANDARD
1	Body	Cast Iron	ASTM A126 CLASS B
2	Seat Rings	Cast Bronze	ASTM B62
3	Wedge Face Rings	Cast Bronze	ASTM B62
4	Wedge	Cast Iron	ASTM A126 CLASS B
5	Wedge Nut	Cast Brass	ASTM B62
6	Stem	Brass	ASTM B16
7	Body Gasket	Graphite	NON ASBESTOS
8	Bolts	Steel	ASTM A307 B
9	Nuts	Steel	ASTM A307 B
10	Bonnet	Cast Iron	ASTM A126 CLASS B
11	Gland Follower Bolts	Steel	ASTM A307 B
12	Suffing Box Gasket	Graphite	ASTM A126 CLASS B
13	Suffing Box	Cast Iron	ASTM A307 B
14	Packing	Graphite	NON ASBESTOS
15	Gland Follower	Ductile Iron	ASTM A536 65-45-12
16	Packing Gland	Cast Brass	ASTM B584
17	Handwheel	Cast Iron	ASTM A126 CLASS B
18	Identification Plate	Aluminium	
19	Washer	Steel	ASTM A307 B
20	Handwheel Nut	Steel	ASTM A307 B

Non-Rising Stem Solid Wedge Gate Valve (BS5150)

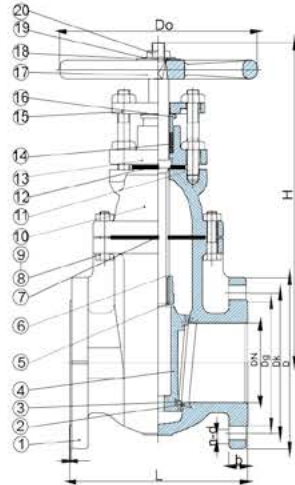

DIMENSIONS-INCHES AND MILLIMETRES

VALVE SIZE	DIM.								
	L	Dg	Dk	D	b	f	n-d	Do	H
50	178	102	125	165	20	2	4-19	178	210
65	190.5	122	145	185	20	2	4-19	178	237
80	203.2	138	160	200	22	2	8-19	200	274
100	228.6	158	180	220	24	2	8-19	254	300
125	254	188	210	250	26	2.5	8-19	300	364
150	266.7	212	240	285	26	2.5	8-23	300	404
200	292	268	295	340	30	2.5	12-23	348	497
250	330	320	355	405	32	2.5	12-28	400	590
300	356	378	410	460	32	2.5	12-28	457	667
350	381	438	470	520	36	3	16-28	508	882
400	406	490	525	580	38	3	16-31	558	956
450	432	550	585	640	40	3	20-31	610	1027
500	457	610	650	715	42	3	20-34	640	1106
600	508	725	770	840	48	3.5	20-37	762	1258

NO.	PART	MATERIAL	STANDARD
1	Body	Cast Iron	BS1452 Cr.180
2	Seat Rings	Cast Bronze	BS1400 LG2
3	Wedge Face Rings	Cast Bronze	BS1400 LG2
4	Wedge	Cast Iron	BS1452 Cr.180
5	Wedge Nut	Cast Bronze	BS1400 LG2
6	Stem	Brass	BS2874 CZ122
7	Body Gasket	Graphite	BS2494 Type W
8	Bolts	Steel	BS970 43A
9	Nuts	Steel	BS970 43A
10	Bonnet	Cast Iron	BS1452 Cr.180
11	Gland Follower Bolts	Steel	BS970 43A
12	Stuffing Box Gasket	Graphite	BS2494 Type W
13	Stuffing Box	Cast Iron	BS1452 Cr.180
14	Packing	Graphite	BS2494 Type W
15	Gland Follower	Ductile Iron	BS2789 Gr.420-12
16	Packing Gland	Cast Brass	BS1400 PCB1
17	Handwheel	Cast Iron	BS1452 Cr.180
18	Identification Plate	Aluminium	
19	Washer	Steel	BS970 43A
20	Handwheel Nut	Ductile Iron	BS2789 Gr.420-12



- Conforms to BS5150 PN16 & BS5163
- Flanges drilled to BS4504
- Face to Face dimensions conform to BS5150 Series 3.
- Nominal pressure:1.6Mpa
- Seat Test pressure: 1.6Mpa
- Shell Test pressure:2.4Mpa
- Suitable temperatures 230°C
- Suitable media: water, oil, gas





Non-Rising Stem Metal Seated Gate Valve (DIN 3202 F4/F5)

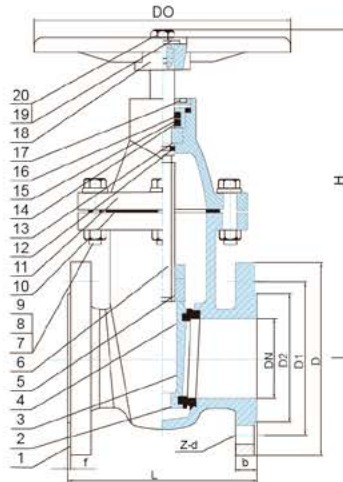

- Conforms to DIN3352
- Face to Face dimensions conform to F4/F5 of DIN3202.
- Flanges drilled to DIN 2532/ DN 2533
- Suitable media: water, oil, gas.

CAST IRDN GATE VALVE FLANGED NRS TD DIN3352 PN16

DN	D	D1	D2	L		b	H	f	Z-d	D0
				F4	F5					
Ø40	Ø150	Ø110	Ø84	140	240	18	214	3	4-Ø19	Ø180
Ø50	Ø165	Ø125	Ø99	150	250	20	232	3	4-Ø19	Ø200
Ø65	Ø185	Ø145	Ø118	170	270	20	258	3	4-Ø19	Ø200
Ø80	Ø200	Ø160	Ø132	180	280	22	281	3	8-Ø19	Ø220
Ø100	Ø220	Ø180	Ø156	190	300	24	315	3	8-Ø19	Ø250
Ø125	Ø250	Ø210	Ø184	200	325	26	358	3	8-Ø19	Ø280
Ø150	Ø285	Ø240	Ø211	210	350	26	408	3	8-Ø23	Ø280
Ø200	Ø340	Ø295	Ø266	230	400	30	500	3	12-Ø23	Ø320
Ø250	Ø405	Ø355	Ø319	250	450	32	572	3	12-Ø28	Ø350
Ø350	Ø520	Ø470	Ø429	270	500	36	751	4	16-Ø28	Ø450
Ø400	Ø580	Ø525	Ø480	290	550	38	832	4	16-Ø31	Ø450

DN	PART NAME	MATERIAL	STANDARD
1	Body	Gray Cast Iron	GG25
2	Body Seat Ring	Brass	
3	Wedge	Ductile Iron	GGG50
4	Wedge Seat Ring	Brass	
5	Stem Nut	Brass	
6	Stem	Stainless Steel	2Cr13
7	Bonnet Bolt	Carbon Steel	A3
8	Nut	Carbon Steel	A3
9	Washer	Carbon Steel	A3
10	Gasket	Nbr	
11	Bonnet	Gray Cast Iron	GG25
12	O-Ring	Nbr	
13	Locating Ring	Brass	
14	O-Ring	Nbr	
15	Bonnet Nut	Brass	
16	Minipad	Tfl	
17	Dust Ring	Nbr	
18	Wheel	Ductile Iron	GGG50
19	Washer	Carbon Steel	A3
20	Bolt	Carbon Steel	A3



Rising Stem Solid Wedge Gate Valve (ANSI B16.10)

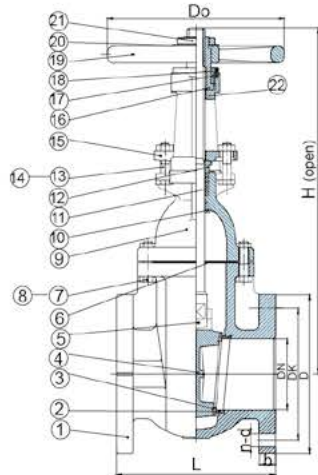

DIMENSIONS IN INCHES AND MILLIMETRES

DN	L	Dk	D	b	n-d	Do	H
2"	178	121	152	15.9	4-19	178	380
2.5"	190.5	140	178	17.5	4-19	178	430
3"	203.2	152.5	190	19.1	4-19	200	485
4"	228.6	190.5	228.6	23.5	8-19	254	615
5"	254	215.9	254	23.8	8-22	300	700
6"	266.7	241.3	279.4	25.4	8-22	300	835
8"	292	298.5	343	28.6	8-22	348	1010
10"	330	362	406	30.2	12-25	400	1220
12"	356	432	483	31.8	12-25	457	1435
14"	381	476	533	35	12-29	508	1655
16"	406	540	597	36.6	16-29	558	1825
18"	432	578	635	39.7	16-32	610	2020
20"	457	635	699	42.9	20-32	640	2290
24"	508	749	813	47.6	20-35	762	3360
30"	610	914	984	54	28-35	813	3665
36"	711	1086	1168	60.3	32-42	813	3920

NO.	PART	MATERIAL	STANDARD
1	Body	Cast Iron	ASTM A126 CLASS B
2	Seat Rings	Cast Bronze	ASTM B62
3	Wedge Face Rings	Cast Bronze	ASTM B62
4	Wedge	Cast Iron	ASTM A126 CLASS B
5	Stem	Brass	ASTM B16
6	Body Gasket	Graphite	NON ASBESTOS
7	Bolts	Steel	ASTM A307 B
8	Nuts	Steel	ASTM A307 B
9	Bonnet	Cast Iron	ASTM A126 CLASS B
10	Back Seat Bushing	Cast Brass	ASTM B584
11	Packing	Graphite	NON ASBESTOS
12	Packing Gland	Cast Brass	ASTM B584
13	Gland Follower Bolts	Steel	ASTM A307 B
14	Gland Follower Nuts	Steel	ASTM A307 B
15	Gland Follower	Ductile Iron	ASTM A536 65-45-12
16	Yoke Bushing	Cast Bronze	ASTM B62
17	Yoke Bushing Nut	Cast Iron	ASTM A126 CLASS B
18	Screw	Steel	ASTM A307 B
19	Handwheel	Cast Iron	ASTM A126 CLASS B
20	Identification Plate	Aluminium	
21	Handwheel Nut	Ductile Iron	ASTM A536 65-45-12
22	Yoke	Cast Iron	ASTM A126 CLASS B



- Conforms to MSS SP-70
- Flanges drilled to ANSI B16.1(125LB)
- Face to Face dimensions conform to ANSI B16.10(125LB)
- Working pressure: 125S, 200WOG. With MSS SP-70
- Suitable media: water, oil, gas
- Construction available in all iron.
- Yoke construction for sizes 50, 65 & 80 have 1 piece bonnet/yoke.





- Conforms to BS5150 PN16 & BS5163
- Flanges drilled to BS4504
- Face to Face dimensions conform to BS5150 Series 3.
- Nominal pressure: 1.6Mpa
- Seat Test pressure: 1.6Mpa
- Shell Test pressure 2.4Mpa
- Suitable temperatures $\leq 230^{\circ}\text{C}$
- Suitable media: water, oil, gas



BS5150/BS5163

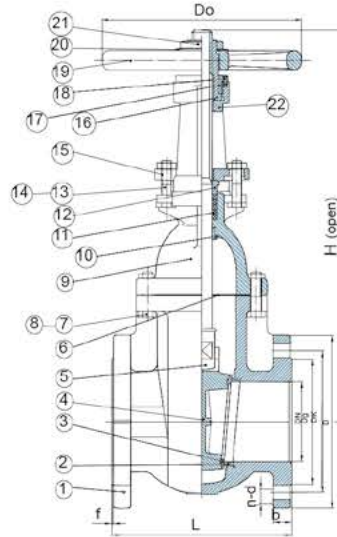

DIMENSIONS-INCHES AND MILLIMETRES

VALVE SIZE	DIM.									
	L	Dg	Dk	D	b	f	n-d	Do	H	
50	178	102	125	165	20	2	4-19	178	380	
65	190.5	122	145	185	20	2	4-19	178	430	
80	203.2	138	160	200	22	2	8-19	200	485	
100	228.6	158	180	220	24	2	8-19	254	615	
125	254	188	210	250	26	2.5	8-19	300	700	
150	266.7	212	240	285	26	2.5	8-23	300	835	
200	292	268	295	340	32	2.5	12-23	348	1010	
250	330	320	355	405	32	2.5	12-28	400	1220	
300	356	378	410	460	32	2.5	12-28	457	1435	
350	381	438	470	520	36	3	16-28	508	1655	
400	406	490	525	580	38	3	16-31	558	1825	
450	432	550	585	640	40	3	20-31	610	2020	
500	457	610	650	715	42	3	20-34	640	2290	
600	508	725	770	840	48	3.5	20-37	762	3665	

NO.	PART	MATERIAL	STANDARD
1	Body	Cast Iron	BS1452 Cr.180
2	Seat Rings	Cast Bronze	BS1400 LG2
3	Wedge Face Rings	Cast Bronze	BS1400 LG2
4	Wedge	Cast Iron	BS1452 Cr.180
5	Stem	Brass	BS2874 CZ122
6	Body Gasket	Graphite	BS2494 Type W
7	Bolts	Steel	BS970 43A
8	Nuts	Steel	BS970 43A
9	Bonnet	Cast Iron	BS1452 Cr.180
10	Back Seat Bushing	Cast Brass	BS1400 PCB1
11	Packing	Graphite	BS2494 Type W
12	Packing Gland	Cast Brass	BS1400 PCB1
13	Gland Follower Bolts	Steel	BS970 43A
14	Gland Follower Nuts	Steel	BS970 43A
15	Gland Follower	Ductile Iron	BS2789 Gr.420-12
16	Yoke Bushing	Cast Bronze	BS1400 LG2
17	Yoke Bushing Nut	Cast Iron	BS1452 Cr.180
18	Screw	Steel	BS970 43A
19	Handwheel	Cast Iron	BS1452 Cr.180
20	Identification Plate	Aluminium	
21	Handwheel Nut	Ductile Iron	BS2789 Gr.420-12
22	Yoke	Cast Iron	BS1452 Cr.180

Rising Stem Resilient Seated Gate Valve (ANSI B16.10)

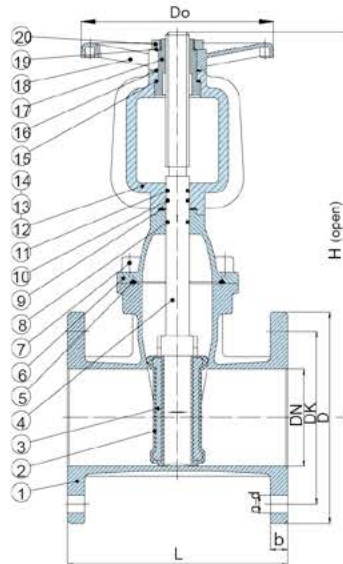

DN	L	DK	D	b	n-d	Do	H
2"	178	120.5	152	15.9	4-19	160	380
2-1/2"	190	139.5	178	17.5	4-19	200	430
3"	203	152.5	191	19.1	4-19	200	485
4"	229	190.5	229	23.9	8-19	200	615
5"	254	216	254	23.9	8-22	250	700
6"	267	241.5	279	25.4	8-22	250	835
8"	292	298.5	343	28.6	8-22	320	1010
10"	330	362	406	30.2	12-25	370	1220
12"	356	432	483	31.8	12-25	370	1435
14"	381	476	533	35	12-29	450	1655
16"	406	539.5	597	36.6	16-29	450	1825
18"	432	578	635	39.7	16-32	640	2020
20"	457	635	699	42.9	20-32	640	2290
24"	508	749.5	813	47.7	20-35	640	3665

NO.	PART	MATERIAL	STANDARD
1	Body	Ductile Iron	ASTM A536 65-45-12
2	Resilient wedge	Ductile Iron +EPDM	ASTM A536 65-45-12+EPDM
3	Wedge skeleton	Ductile Iron	ASTM A536 65-45-12
4	Stem	Stainless Steel	SS410
5	Gasket	EPDM	EPDM
6	Bonnte	Ductile Iron	ASTM A536 65-45-12
7	Bolts	Steel	ASTM A307 B
8	O-Ring	EPDM	EPDM
9	Gasket	PTFE	PTFE
10	O-Ring	EPDM	EPDM
11	O-Ring	EPDM	EPDM
12	Yoke	Ductile Iron	ASTM A536 65-45-12
13	Bolts	Steel	ASTM A307 B
14	Nuts	Steel	ASTM A307 B
15	Gasket	PTFE	PTFE
16	Gasket	PTFE	PTFE
17	Yoke Bushing	Brass	ASTM B16
18	Handwheel	Ductile Iron	ASTM A536 65-45-12
19	Identification plate	Aluminium	Aluminium
20	Handwheel Nut	Brass	ASTM B16



- Conform to AWWA C509
- Face to Face dimension conforms to ANSI16.10(125LB)
- Flanges drilled conforms to ANSI16.10(125LB)
- Suitable media:water





Rising Stem Resilient Seated Gate Valve (BS5163)

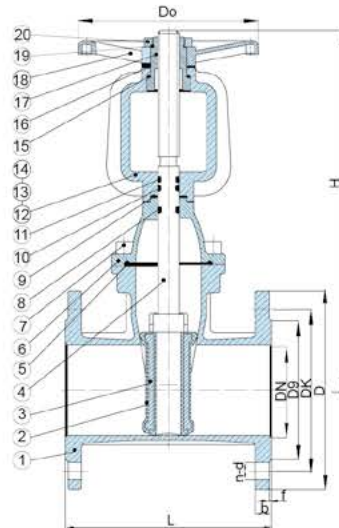

- Conforms to BS5163&BS5150
- Face to face dimensions conforms to BS5163
- Flanges drilled conforms to BS4504&EN1092
- Suitable media:water
- Suitable temperature < 100°C
- Nominal pressure:1.6Mpa
- Seat Test pressure: 1.6Mpa
- Shell Test pressure:2.4Mpa

NO.	PART	MATERIAL	STANDARD
1	Body	Ductile Iron	BS2789 Gr450/10
2	Resilient wedge	Ductile Iron +EPDM	BS2789 Gr450/10+EPDM
3	Wedge skeleton	Ductile Iron	BS2789 Gr450/10
4	Stem	Stainless Steel	BS410 S21
5	Gasket	EPDM	EPDM
6	Bonnte	Ductile Iron	BS2789 Gr450/10
7	Bolts	Steel	BS970 43A
8	O-Ring	EPDM	EPDM
9	Gasket	PTFE	PTFE
10	O-Ring	EPDM	EPDM
11	O-Ring	EPDM	EPDM
12	Yoke	Ductile Iron	BS2789 Gr450/10
13	Bolts	Steel	BS970 43A
14	Nuts	Steel	BS970 43A
15	Gasket	PTFE	PTFE
16	Gasket	PTFE	PTFE
17	Yoke Bushing	Brass	BS1400 LG2
18	Handwheel	Ductile Iron	BS2789 Gr450/10
19	Identification plate	Aluminium	Aluminium
20	Handwheel Nut	Brass	BS1400 LG2



DN	L	Dg		DK		D		f	b		n-d		Do	H
		1.0MPa	1.6MPa	1.0MPa	1.6MPa	1.0MPa	1.6MPa		1.0MPa	1.6MPa	1.0MPa	1.6MPa		
50	178	99		125		165		3	19		4-19		160	410
65	190	118		145		185		3	19		4-19		200	487
80	203	132		160		200		3	19		8-19		200	538
100	229	156		180		220		3	19		8-19		200	620
125	254	184		210		250		3	19		8-19		250	673
150	267	211		240		285		3	19		8-23		250	726
200	292	265		295		340		3	20		8-23	12-23	320	867
250	330	319		350	355	400		3	22		12-23	12-28	370	1042
300	356	370		400	410	455		4	24.5		12-23	12-28	370	1297
350	381	429		460	470	520		4	24.5	26.5	16-23	12-29	450	1453
400	406	480		515	525	580		4	24.5	28	16-28	16-28	450	1692
450	432	530	548	565	585	615	640	4	25.5	30	20-28	16-31	640	1852
500	457	582	609	620	650	670	715	4	26.5	31.5	20-28	20-34	640	2023
600	508	682	720	725	770	780	840	5	30	36	20-31	20-37	640	2412

Rising Stem Resilient Seated Gate Valve (DIN3202-F4/F5)

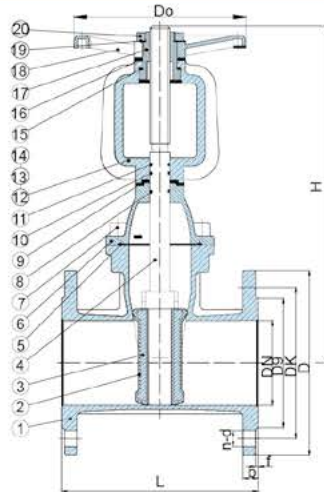

NO.	PART	MATERIAL	STANDARD
1	Body	Ductile Iron	GGG50
2	Resilient wedge	Ductile Iron +EPDM	GGG50+EPDM
3	Wedge skeleton	Ductile Iron	GGG50
4	Stem	Stainless Steel	SS410
5	Gasket	EPDM	EPDM
6	Bonnte	Ductile Iron	GGG50
7	Bolt	Steel	SS304
8	O-Ring	EPDM	EPDM
9	Gasket	PTFE	PTFE
10	O-Ring	EPDM	EPDM
11	O-Ring	EPDM	EPDM
12	Yoke	Ductile Iron	GGG50
13	Bolt	Steel	SS304
14	Nuts	Steel	SS304
15	Gasket	PTFE	PTFE
16	Gasket	PTFE	PTFE
17	Yoke Bushing	Brass	CuZn39Pb
18	Handwheel	Ductile Iron	BS2789 Gr450/10
19	Identification plate	Aluminium	GGG50
20	Handwheel Nut	Brass	CuZn39Pb

- Conforms to DIN3352
- Flanges drilled to DIN2533 & EN1092
- Face to Face dimensions
- Conform to DIN3202 F4/F5.
- Suitable media:water
- Suitable temperatures100°C
- Nominal pressure:1.6Mpa
- Seat Test pressure: 1.6Mpa
- Shell Test pressure:2.4Mpa

DN	L		Dg		DK		D		f	b		n-d		Do	H
	F4	F5	1.0MPa	1.6MPa	1.0MPa	1.6MPa	1.0MPa	1.6MPa		1.0MPa	1.6MPa	1.0MPa	1.6MPa		
40	140	240	84	110	150	3	18	4-19	160	360					
50	150	250	99	125	165	3	19	4-19	160	410					
65	170	270	118	145	185	3	19	4-19	200	487					
80	180	280	132	160	200	3	19	8-19	200	538					
100	190	300	156	180	220	3	19	8-19	200	620					
125	200	325	184	210	250	3	19	8-19	250	673					
150	210	350	211	240	285	3	19	8-23	250	726					
200	230	400	265	295	340	3	20	8-23 12-23	320	867					
250	250	450	319	350 355	400	3	22	12-23 12-28	370	1042					
300	270	500	370	400 410	455	4	24.5	12-23 12-28	370	1297					
350	290	550	429	460 470	520	4	24.5 26.5	16-23 12-29	450	1453					
400	310	600	480	515 525	565	4	24.5 28	12-27 16-28	450	1296					
450	330	650	530 548	565 585	615 640	4	25.5 30	16-27 16-31	640	1675					
500	350	700	582 609	620 650	670 715	4	26.5 31.5	20-28 20-34	640	2023					
600	390	800	682 720	725 770	780 840	5	30 36	20-31 20-37	640	2412					





- Inside Screw
- Bolt Bonnet
- Non-Rising Stem
- Rubber Encapsulated Wedge
- Low-Torque Operation
- Flanged Ends

BASIC DESIGN STANDARDS	
BASIC DESIGN	BS5163
FACE TO FACE	BS5163
FLANGES	BS4504 PN16
TESTING	BS6755



Non-Rising Stem Gate Valve With Changeable O-Ring (BS5163)

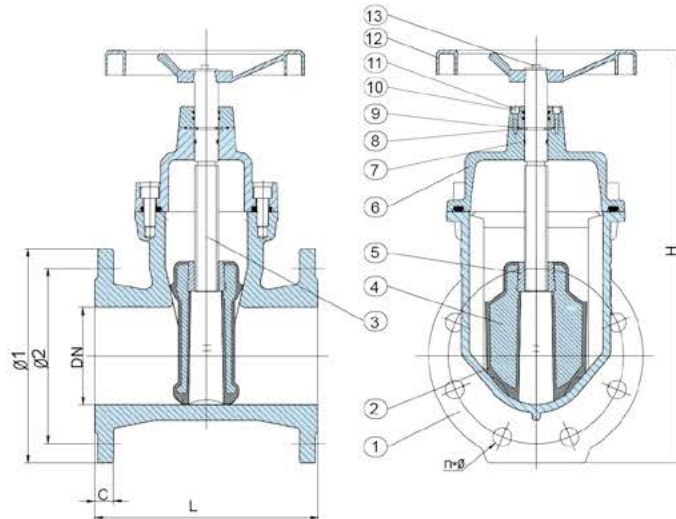

TECHNICAL DATA

NOMINAL DIAMETER		DN40-DN500	mm
NOMINAL PRESSURE		1.6	
TESTING PRESSURE	SHELL TEST	2.4	Mpa
	SEALING TEST	1.76	

STANDARD MATERIALS OF MAIN PARTS

NO.	PART	MATERIAL
1	Body	Ductile Iron
2	Seat	EPDM
3	Shaft	Stainless Steel 420
4	Disc	Ductile Iron
5	Wedge Nut	Brass
6	Bonnet	Ductile Iron
7	O ring	EPDM
8	Thrust Washer	Brass
9	Sealing ring	EPDM
10	socket head screw	Carbon Steel
11	Oring	EPDM
12	Hand Wheel	Ductile Iron
13	Stem Nut	Brass

SIZE	DN	L	H	BS4504 PN10/16			C
				Φ1	Φ2	N*Φ	
DN40	Φ40	165	285	Φ150	Φ110	4-Φ18	17
DN50	Φ50	178	300	Φ165	Φ125	4-Φ18	18
DN65	Φ65	190	345	Φ185	Φ145	4-Φ18	18
DN80	Φ80	203	390	Φ200	Φ160	4/8-Φ18	18
DN100	Φ100	229	430	Φ220	Φ180	8-Φ18	19
DN125	Φ125	254	510	Φ250	Φ210	8-Φ18	19
DN150	Φ150	267	565	Φ285	Φ240	8-Φ22	19
DN200	Φ200	292	680	Φ340	Φ295	8/12-Φ22	22
DN250	Φ250	330	820	Φ395/Φ405	Φ350/Φ355	12-Φ23/Φ26	22
DN300	Φ300	356	930	Φ445/Φ460	Φ400/Φ410	12-Φ23/Φ26	26
DN350	Φ350	381	1020	Φ505/Φ520	Φ460/Φ470	16-Φ23/Φ26	30
DN400	Φ400	406	1100	Φ565/Φ580	Φ515/Φ525	16-Φ26/Φ30	30
DN500	Φ500	457	1250	Φ670/Φ715	Φ620/Φ650	20-Φ26/Φ33	32

Non-Rising Stem Resilient Seated Gate Valve With Changeable O-Ring (DIN3202-F4/F5)

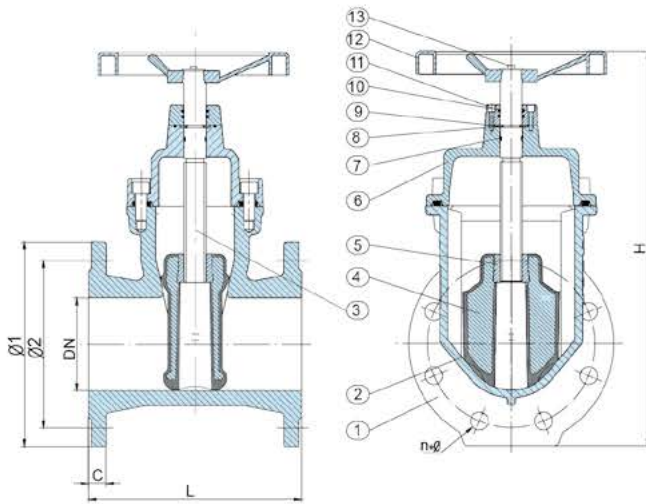

TECHNICAL DATA

NOMINAL DIAMETER		DN40-DN500	mm
NOMINAL PRESSURE		1.6	
TESTING PRESSURE	SHELL TEST	2.4	Mpa
	SEALING TEST	1.76	

STANDARD MATERIALS OF MAIN PARTS

NO.	PART	MATERIAL
1	Body	Ductile Iron
2	Seat	EPDM
3	Shaft	Stainless Steel 420
4	Disc	Ductile Iron
5	Wedge Nut	Brass
6	Bonnet	Ductile Iron
7	O ring	EPDM
8	Thrust Washer	Brass
9	Sealing ring	EPDM
10	socket head screw	Carbon Steel
11	Oring	EPDM
12	Hand Wheel	Ductile Iron
13	Stem Nut	Brass

- Inside Screw
- Bolt Bonnet
- Non-Rising Stem
- Rubber Encapsulated Wedge
- Low-Torque Operation
- Flanged Ends

BASIC DESIGN STANDARDS	
BASIC DESIGN	DIN3352
FACE TO FACE	DIN3202-F4/F5
FLANGES	DIN2533 PN16
TESTING	DIN3230

SIZE	DN	L		H	DIN PN10/16			C
		F4	F5		$\phi 1$	$\phi 2$	N* ϕ	
DN40	$\phi 40$	140	240	285	$\phi 150$	$\phi 110$	4- $\phi 18$	17
DN50	$\phi 50$	150	250	300	$\phi 165$	$\phi 125$	4- $\phi 18$	18
DN65	$\phi 65$	170	270	345	$\phi 185$	$\phi 145$	4- $\phi 18$	18
DN80	$\phi 80$	180	280	390	$\phi 200$	$\phi 160$	4/8- $\phi 18$	18
DN100	$\phi 100$	190	300	430	$\phi 220$	$\phi 180$	8- $\phi 18$	19
DN125	$\phi 125$	200	325	510	$\phi 250$	$\phi 210$	8- $\phi 18$	19
DN150	$\phi 150$	210	350	565	$\phi 285$	$\phi 240$	8- $\phi 22$	19
DN200	$\phi 200$	230	400	680	$\phi 340$	$\phi 295$	8/12- $\phi 22$	22
DN250	$\phi 250$	250	450	820	$\phi 395/\phi 405$	$\phi 350/\phi 355$	12- $\phi 23/\phi 26$	22
DN300	$\phi 300$	270	500	930	$\phi 445/\phi 460$	$\phi 400/\phi 410$	12- $\phi 23/\phi 26$	26
DN350	$\phi 350$	290	550	1020	$\phi 505/\phi 520$	$\phi 460/\phi 470$	16- $\phi 23/\phi 26$	30
DN400	$\phi 400$	310	600	1100	$\phi 565/\phi 580$	$\phi 515/\phi 525$	16- $\phi 26/\phi 30$	30
DN500	$\phi 500$	350	700	1250	$\phi 670/\phi 715$	$\phi 620/\phi 650$	20- $\phi 26/\phi 33$	32



• CHECK VALVE



- 1. Small in size, light in weight, compact in structure, easy in maintenance.
- 2. Two torsion springs are used exerting on each of the pair valve plates, which close the plates quickly and automatically.
- 3. The quick-close action prevents the medium from flowing back and eliminates water hammer effect.
- 4. Short body structure length and good rigidity.
- 5. This valve is tightly sealed, without leakage under the pressure water test.
- 6. Safe and reliable in operation, high interference-resistance.



Note: The stem of the valve should be perpendicular to the horizontal level when the valve is mounted on horizontal pipeline. For vertical installation the direction of flow should be downward.

Through precise manufacture, the main parts of check butterfly valve ensure valve's operation in a long stable and reliable and reliable condition.

Body

Short body structure length and good rigidity.

Disc

Adopting unitized design of dual discs and two torsion springs, it can make disc quickly closed itself and remove water-hammer

Rubber seat

It will be cured on body, tight fit and tight seal with no leakage.

Spring

It is possible to install valve on any positing of pipeline under the function of spring with low cost.

Gasket

It effectively prevents rotating shaft moving and avoid failure of valve function and leakage on shaft end.

Fasten screw

It is possible to regulate fitting clearance using washer and ensure the sealing of disc.

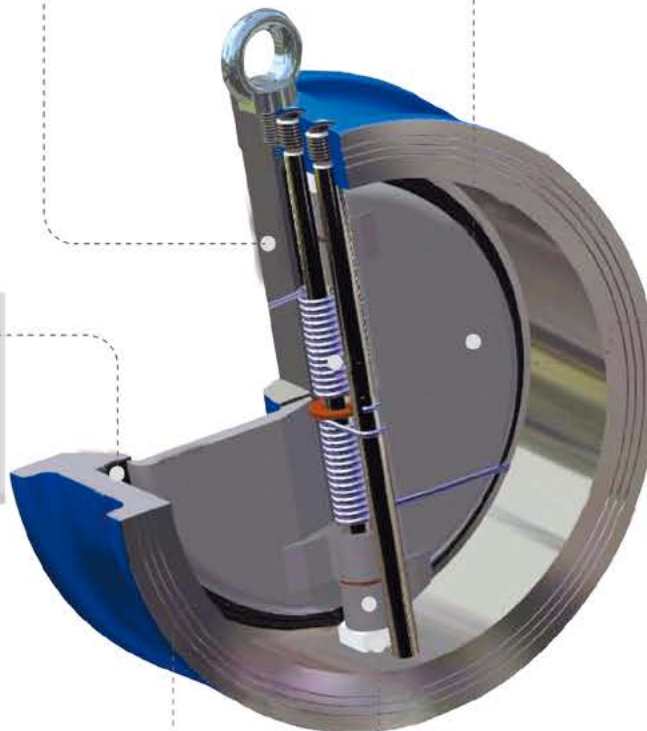



- Suitable media: water, sewage, sea water, air, foodstuff, oil etc.
- Working Temperature: -10°C~120°C



Dual Plate Wafer Check Valve

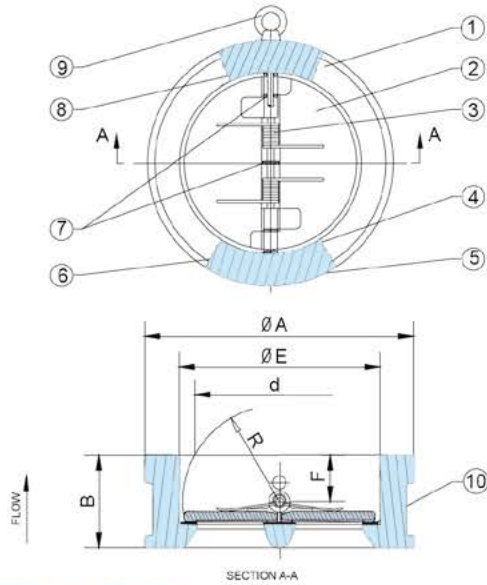

STANDARND MATERIALS OF PARTS

NO.	PART	MATERIAL
1	Body	Cast Iron, Ductile Iron
2	Plate	Ductile Iron+Ni, CF8, CF8M, Bronze
3	Spring	Stainless Steel
4	Hinge Pin	Stainless Steel
5	Plug	Carbon Steel
6	Body Bearing	PTFE
7	Spring Bearing	PTFE
8	Stop Pin	Stainless Steel
9	Eye Bolt	Carbon Steel
10	Body Seat	NBR, EPDM, Viton, Neoprene

DIMENSIONS

SIZE		B	E	F	R	d	A	
in	DN						DIN PN10/16	ANSI150
2	50	43	65	19	28.8	43.3	107	102
2-1/2	65	46	80	20	36.1	60.2	127	121
3	80	64	94	28	43.4	66.4	142	133
4	100	64	117	27	52.8	90.8	162	171
5	125	70	145	30	65.7	116.9	192	193
6	150	76	170	30	78.6	144.6	218	219
8	200	89	224	31	104.4	198.2	273	276
10	250	114	265	33	127	233.7	328	336
12	300	114	310	50	148.3	283.9	378/382	406
14	350	127	360	43	172.4	332.9	438/442	448
16	400	140	410	45	197.4	381	488/495	511
18	450	152	450	52	217.8	419.9	538/555	546
20	500	152	505	58	241	467.8	592/617	603
24	600	178	624	73	295.4	572.6	695/734	714
28	700	229	720	98	354	680	809	828
32	800	241	825	100	398	770.5	916	936

Swing Check Valve (ANSI B16.10)

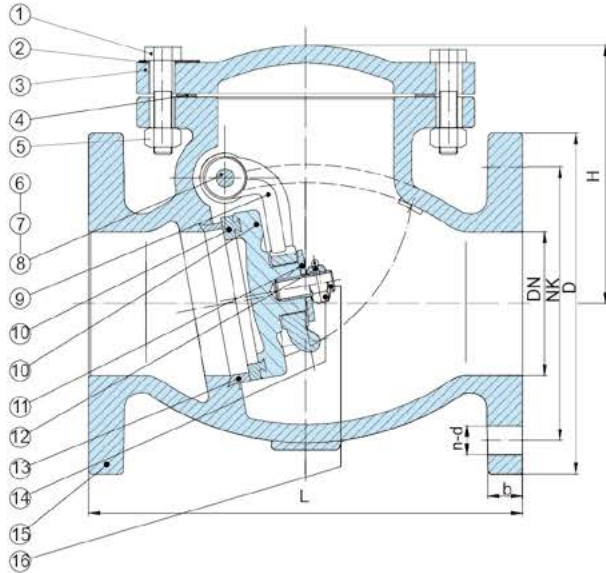

DIMENSIONS IN INCHES AND MILLIMETRES

DN	2"	2.5"	3"	4"	5"	6"	8"	10"	12"	14"	16"
L	203.2	215.9	241.3	292	330.2	355.6	495	622	698.5	787	914
DK	121	140	152.5	190.5	215.9	241	298.5	362	432	476	540
D	152	178	190	228.6	254	279.4	343	406.4	483	533	597
b	15.9	17.5	19	24	23.4	25.4	30	31	31.8	35	36.6
n-d	4-19	4-19	4-19	8-19	8-22	8-22	8-22	12-25	12-25	12-29	16-29
H	113	133	144	168	198	217	261	287	319	443	595.5

NO.	PART	MATERIAL	STANDARD
1	Bolts	Steel	ASTM A307 B
2	Identification Plate	Aluminium	
3	Bonnet	Cast Iron	ASTM A126 CLASS B
4	Body Gasket	Graphite	NON ASBESTOS
5	Nuts	Steel	ASTM A307 B
6	Side Plug	Brass	ASTM B16
7	Gasket	Fiber	
8	Hanger Pin	Brass	ASTM B16
9	Hanger	Ductile Iron	ASTM A536 65-45-12
10	Disc Ring	Cast Bronze	ASTM B62
10'	Disc	Cast Iron	ASTM A126 CLASS B
11	Washer	Steel	ASTM A307 B
12	Split Pin	Stainless Steel	ASTM 420 S42000
13	Seat Ring	Cast Bronze	ASTM B62
14	Disc Nut	Steel	ASTM A307 B
15	Body	Cast Iron	ASTM A126 CLASS B
16	Stud Bolt	Steel	ASTM A307 B



DESCRIPTION:

- 1.Conforms to MSS SP-71.
- 2.Flange drilled to ANSI B16.1(125lb).
- 3.Face to Face Dimension Conform to ANSI B16.10 (125lb).
- 4.Working Pressure: 125LB
- 5.Suitable Media: Water, Oil, Gas.
- 6.Only Valve Sizes: 350& above fitted UFTING EYE BOLT.





DESCRIPTION:

- 1. Conform to BS5153 PN16.
- 2. Flange Drilled Conforms to BS4504
- 3. Face to Face Dimensions Conform to Series 2 of BS 5153.



Swing Check Valve (BS5153)

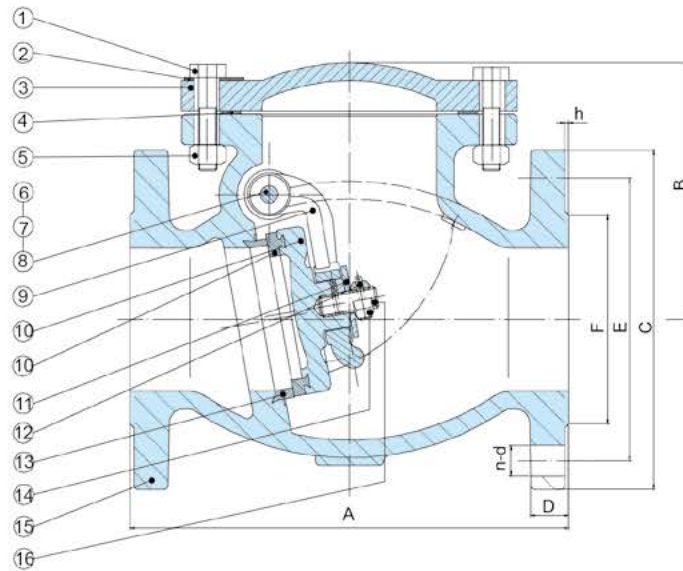

DIMENSIONS-MILLIMETRES

DIM.	VALVE SIZE								
	50	65	80	100	125	150	200	250	300
A	203	216	241	292	330	356	495	622	698
B	113	133	142	163	197	212	257	299	331
C	165	185	200	220	250	285	340	405	450
D	20	20	20	24	26	26	30	32	32
E	125	145	160	180	210	240	295	355	410
F	102	122	138	158	188	212	268	320	378
n-d	4-19	4-19	4-19	8-19	8-19	8-23	12-23	12-28	12-28
h	2	2	2	2	2.5	2.5	2.5	2.5	2.5

NO.	PART	MATERIAL	STANDARD
1	Bolts	Steel	BS970 43A
2	Identification Plate	Aluminium	
3	Bonnet	Cast Iron	BS1452 Cr.180
4	Body Gasket	Graphite	BS2494 Type W
5	Stem	Brass	BS2874 CZ12
6	Nuts	Steel	BS970 43A
7	Side Plug	Brass	BS2874 CZ12
8	Gasket	Fiber	
9	Hanger Pin	Brass	BS2874 CZ12
10	Hanger	Ductile Iron	BS2789 Gr.420-12
11	Disc	Cast Iron	BS1452 Cr.180
12	Disc Ring	Cast Bronze	BS1400 LG2
13	Washer	Steel	BS970 43A
14	Split Pin	Stainless Steel	BS970 420S37
15	Body	Cast Iron	BS1452 Cr.180
16	Stud Bolt	Steel	BS970 43A

Swing Check Valve (DIN 3202 F6)

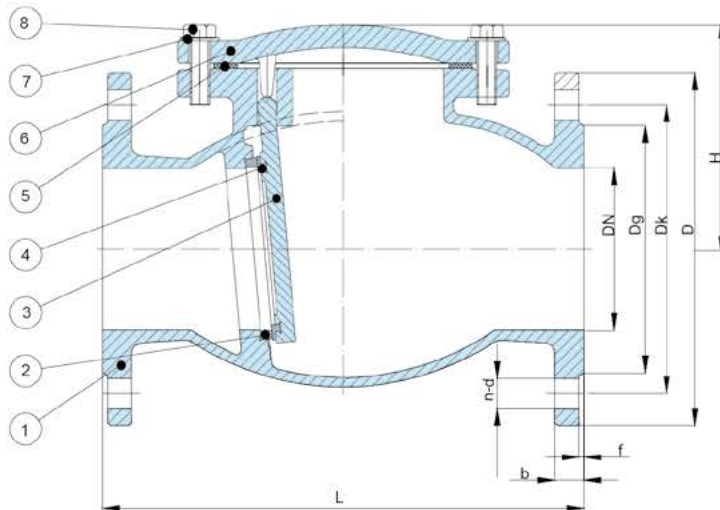

- 1. Conform to DIN 3202.
- 2. Flanges Drilled to DIN2533&EN1092.
- 3. Face to Face Dimensions Conform to DIN 3202 F6.
- 4. Suitable Media: Water.
- 5. Suitable Temperature: $\leq 100^{\circ}\text{C}$.
- 6. Nominal Pressure: 1.0MPa/1.6MPa.

DN	L	Dg		Dk		D		f	b		n-d		H
		1.0MPa	1.6MPa	1.0MPa	1.6MPa	1.0MPa	1.6MPa		1.0MPa	1.6MPa	1.0MPa	1.6MPa	
50	200	99		125		165		3	19		4-19		125
65	240	118		145		185		3	19		4-19		130
80	260	132		160		200		3	19		8-19		160
100	300	156		180		220		3	19		8-19		185
125	350	184		210		250		3	19		8-19		195
150	400	211		240		285		3	19		8-23		205
200	500	265		295		340		3	20		8-23	12-23	285
250	600	319		350	355	405		3	22		12-23	12-28	320
300	700	370		400	410	460		4	24.5		12-23	12-28	340

NO.	PART	MATERIAL	STANDARD
1	Body	Cast Iron	GG25
2	Seat Ring	Cast Bronze	G-CuSn5ZnPb
3	Disc	Cast Iron	GG25
4	Disc Ring	Cast Bronze	G-CuSn5ZnPb
5	Body Gasket	EPDM	EPDM
6	Bonnet	Cast Iron	GG25
7	Identification Plate	Aluminium	
8	Bolts	Steel	A307B



DIN Cast Iron Silent Check Valve PN16



- Available Medium: Water
- Working Temperature: ≤50 °C
- Flange Dimensions: DIN2501-PN10

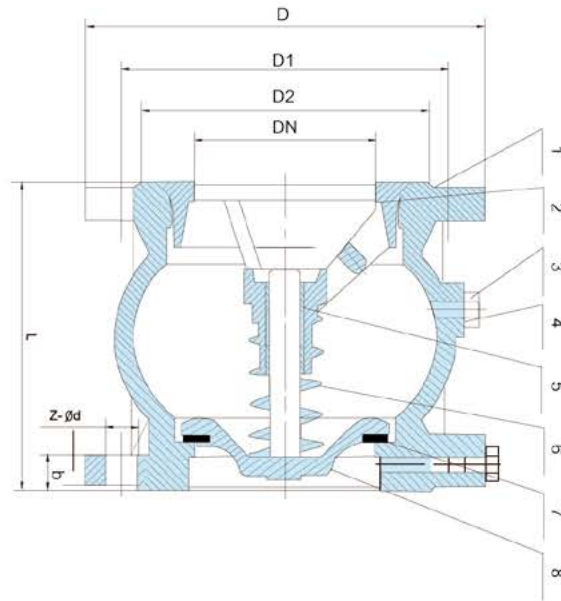

MATERIALS

ITEM	PARTS NAME	MATERIAL
1	Body	Cast Iron
2	Guide Pulley	GGG40
3	Plug	Brass
4	"O"Ring	Rubber
5	Guide Sleeve	Brass
6	Spring	Stainless Steel
7	Gasket	Rubber
8	Disc	GGG40

DIMENSIONS(mm)

DN	L	D	D1	D2	b	Z-φd	f	KG
50	100	165	125	102	20	4-18	3	5.6
65	120	185	145	122	20	4-18	3	8.96
80	140	200	160	138	22	8-18	3	12.26
100	170	220	180	158	24	8-18	3	14.8
125	200	250	210	188	26	8-18	3	23.3
150	230	285	240	212	26	8-23	3	31.2
200	288	340	295	268	30	12-23	3	
250	354	405	355	320	32	12-27	3	
300	410	460	410	378	32	12-27	4	



Globe Valve (ANSI B16.10)

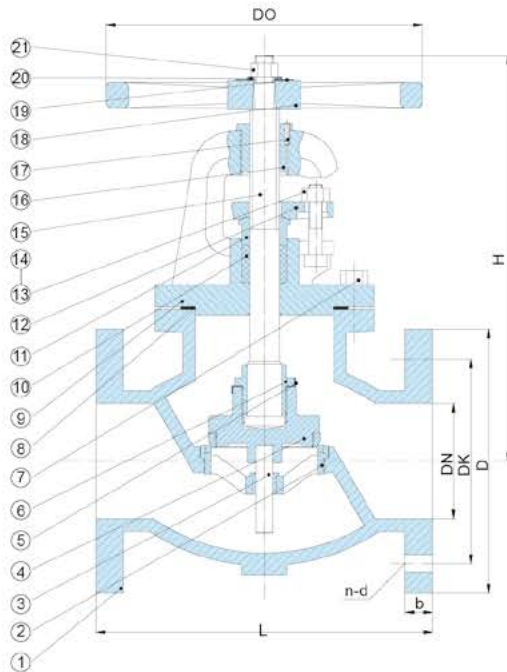

- Usage:
Turn on or turn off the pipelines where the working nominal pressure is $\leq 1.6\text{MPa}$.

NO.	PART	MATERIAL	STANDARD
1	Body	Cast Iron	ASTM A126 CLASS B
2	Seat Ring	Cast Bronze	ASTM B62
3	Reaction Member	Brass	ASTM B16
4	Disc	Cast Bronze	ASTM B62
5	Gasket	Brass	ASTM B16
6	Swivel Nut	Cast Brass	ASTM B584
7	Bolts	Steel	ASTM A307 B
8	Body Gasket	Graphite	NON ASBESTOS
9	Bonnet	Cast Iron	ASTM A126 CLASS B
10	Packing	Graphite	NON ASBESTOS
11	Packing Gland	Cast Brass	ASTM B584
12	Gland Follower	Ductile Iron	ASTM A536 65-45-12
13	Gland Follower Bolts	Steel	ASTM A307 B
14	Gland Follower Nuts	Steel	ASTM A307 B
15	Stem	Brass	ASTM B16
16	Yoke Bushing	Cast Bronze	ASTM B62
17	Screw	Steel	ASTM A307 B
18	Handwheel	Cast Iron	ASTM A126 CLASS B
19	Identification Plate	Aluminium	
20	Washer	Steel	ASTM A307 B
21	Handwheel Nut	Ductile Iron	ASTM A536 65-45-12

DIMENSIONS IN INCHES AND MILLIMETRES

DIM.	VALVE SIZE								
	50	65	80	100	125	150	200	250	300
L	203	216	241.3	292	330	356	495.3	622	698.5
Dk	121	140	152.5	190.5	216	241	299	362	432
D	152	178	191	229	254	279.4	343	406	483
b	15.9	18	19	24	23.8	25	28.6	30.2	31.8
n-d	4-19	4-19	4-19	8-19	8-22	8-22	8-22	12-25	12-25
DO	178	178	200	254	300	300	348	400	457
H	295	330	365	400	450	525	595	685	830





• Usage:

Turn on or turn off the pipelines where the working nominal pressure is $\leq 1.6\text{MPa}$.



Globe Valve (BS5152)

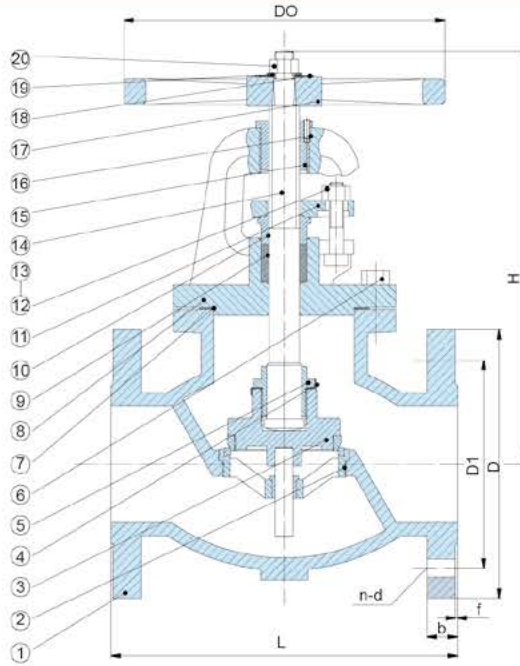

NO.	PART	MATERIAL	STANDARD
1	Body	Cast Iron	BS1452 Cr.180
2	Seat Ring	Cast Bronze	BS1400 LG2
3	Disc	Cast Bronze	BS1400 LG2
4	Gasket	Brass	BS2874 CZ122
5	Swivel Nut	Cast Brass	BS1400 PCB1
6	Bolts	Steel	BS970 43A
7	Body Gasket	Graphite	BS2494 Type W
8	Bonnet	Cast Iron	BS1452 Cr.180
9	Packing	Graphite	BS2494 Type W
10	Packing Gland	Cast Brass	BS1400 PCB1
11	Gland Follower	Ductile Iron	BS2789 Gr.420-12
12	Gland Follower Bolts	Steel	BS970 43A
13	Gland Follower Nuts	Steel	BS970 43A
14	Stem	Brass	BS2874 CZ122
15	Yoke Bushing	Cast Bronze	BS1400 LG2
16	Screw	Steel	BS970 43A
17	Handwheel	Cast Iron	BS1452 Cr.180
18	Identification Plate	Aluminium	
19	Washer	Steel	BS970 43A
20	Handwheel Nut	Steel	BS970 43A

DIM.	VALVE SIZE								
	50	65	80	100	125	150	200	250	300
L	203	216	241	292	330	356	495	622	698
D	165	185	200	220	250	285	340	405	460
D1	125	145	160	180	210	240	295	355	410
b	20	20	22	24	26	26	30	32	32
f	2	2	2	2	2.5	2.5	2.5	2.5	2.5
n-d	4-19	4-19	8-19	8-19	8-19	8-23	12-28	12-28	12-28
DO	178	178	200	254	300	300	348	400	457
H	295	330	365	400	450	525	595	685	830

Y-Strainer

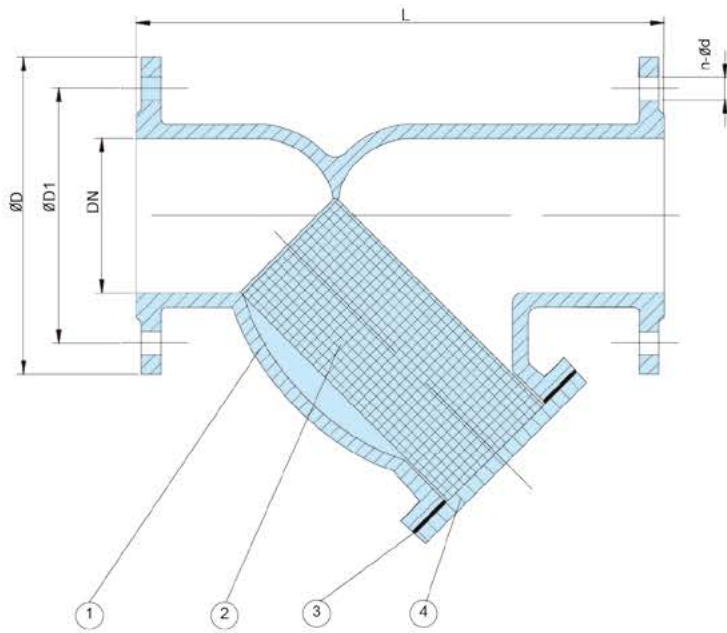

STANDARD MATERIALS OF MAIN PARTS

NO.	PART NAME	MATERIAL
1	Body	Cast Iron
2	Screen	Stainless Steel 304
3	Bonnet	Cast Iron
4	Bolt	Bronze

DIMENSIONS

Nominal DN	L±0.5	D	D1	n- d Ø
50	183	152	120.5	4-19
65	225	178	139.5	4-19
80	250	190.5	152.5	4-19
100	300	229	190.5	8-19
125	325	254	216	8-22
150	355	279	241.5	8-22
200	435	343	298.5	8-22
250	550	406	362	12-25
300	640	483	432	12-25



Nominal Pressure	1.0MPa	1.6MPa
Pressure Test for Sealing	1.1MPa	1.76MPa
Pressure Test for Shell	1.5MPa	2.4MPa
Working Temperature	-10~80℃	
Suitable Medium	Water, Oil, Gas	



Y-Strainer (DIN 3202 F1)

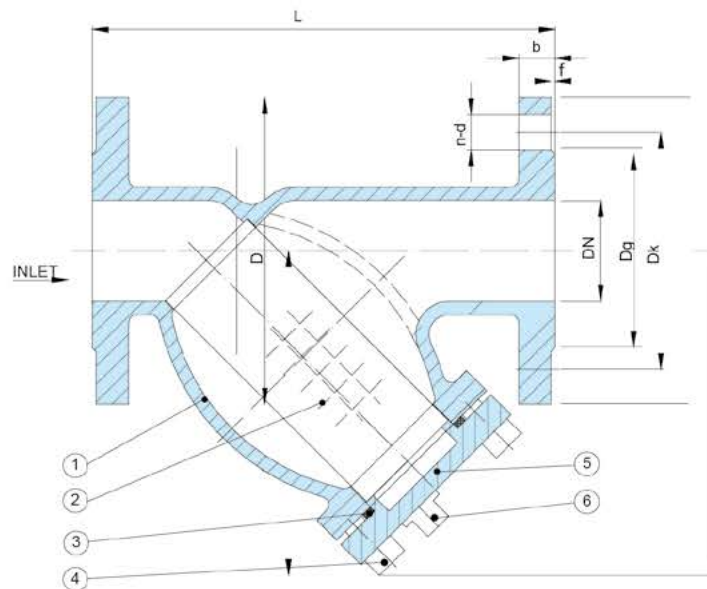

Nominal Pressure	1.0MPa	1.6MPa
Pressure Test for Sealing	1.1MPa	1.76MPa
Pressure Test for Shell	1.5MPa	2.4MPa
Working Temperature	-10~80 °C	
Suitable Medium	Water, Oil, Gas	

NO.	PART	MATERIAL	STANDARD
1	Body	Ductile Iron	GGG50
2	Screen	Stainless Steel304/316	DIN SS304/316
3	Body Gasket	Graphite	
4	Bolts	Steel	DIN RRST37-2
5	Cover	Ductile Iron	GGG50
6	Plug	Stainless Steel	DIN SS304

DIMENSIONS IN INCHES AND MILLIMETRES

DN	L	Dg	DK	D	f	b	n-d	H
15	130	46	65	95	2	14	4-14	68
20	150	56	75	105	2	16	4-14	78
25	160	65	85	115	3	16	4-14	88
32	180	76	100	140	3	18	4-19	98
40	200	84	110	150	3	19	4-19	125
50	230	99	125	165	3	19	4-19	153
65	290	118	145	185	3	19	4-19	183
80	310	132	160	200	3	19	8-19	219
100	350	156	180	220	3	19	8-19	238
125	400	184	210	250	3	19	8-19	279
150	480	211	240	285	3	19	8-23	315
200	600	266	295	340	3	20	12-23	400
250	730	319	355	405	3	22	12-28	482
300	850	370	410	460	4	24.5	12-28	565



Flange (For Butterfly Valve)

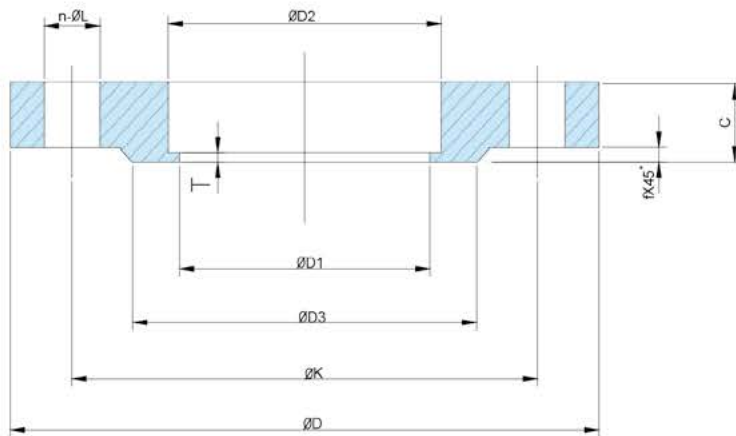

- Nominal Pressure: PN1.0MPa, PN1.6MPa
- Standard: GB/T9119-2000

DIMENSIONS

SIZE	D1	D2	D _k	n-ΦL	T	D3	f	C	D
DN50	50	59	125	4-Φ18	5	102	3	18	165
DN65	65	75	145	4-Φ18	6	122	3	20	185
DN80	80	91	160	8-Φ18	6	133	3	20	200
DN100	100	110	180	8-Φ18	6	158	3	22	220
DN125	125	135	210	8-Φ18	6	184	3	24	250
DN150	150	161	240	8-Φ23	6	212	3	24	285
DN200	208	221	295	8-Φ23	8	268	3	24	340
DN250	255	275	350	12-Φ23	10	320	3	26	395
DN300	308	327	400	12-Φ23	10	370	4	28	445
DN350	340	379	460	16-Φ23	11	430	4	28	505
DN400	405	429	515	16-Φ26	11	482	4	30	565
DN450	455	481	565	20-Φ26	11	532	4	30	615
DN500	505	532	620	20-Φ26	11	585	4	32	670
DN600	605	633	725	20-Φ30	11	685	5	36	780
DN700	705	723	840	24-Φ30	13	800	5	40	895
DN800	810	823	950	24-Φ33	13	905	5	44	1015
DN900	900	923	1050	28-Φ33	13	1005	5	46	1115
DN1000	1000	1023	1160	28-Φ36	13	1110	5	50	1230





Flange (Flat Welding)

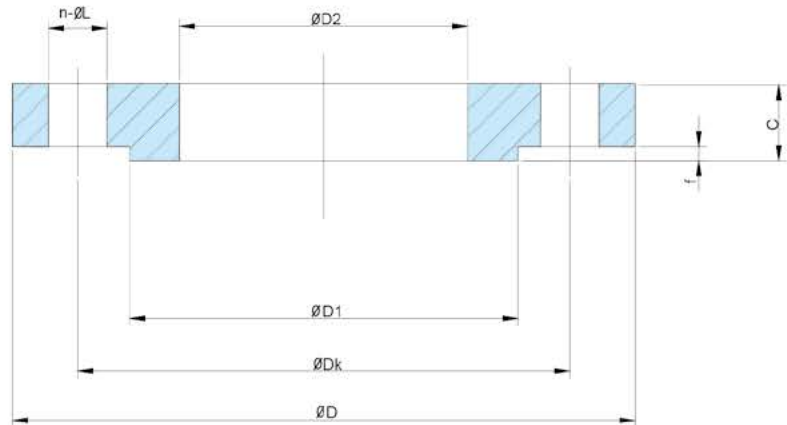

- Nominal Pressure: PN1.0MPa , PN1.6MPa
- Standard: GB/T9119-2000



DIM	D2	D _k	n-ΦL	D1	f	C	D
SIZE							
DN50	59	125	4-Φ18	100	3	18	165
DN65	75	145	4-Φ18	120	3	20	185
DN80	91	160	8-Φ18	135	3	20	200
DN100	110	180	8-Φ18	155	3	22	220
DN125	135	210	8-Φ18	185	3	24	250
DN150	161	240	8-Φ18	210	3	24	285
DN200	222	295	8-Φ18	265	3	24	340
DN250	276	350	12-Φ23	320	3	26	395
DN300	328	400	12-Φ23	368	4	28	445
DN350	380	460	16-Φ23	428	4	28	505
DN400	430	515	16-Φ26	482	4	30	565
DN450	484	565	20-Φ26	532	4	30	615
DN500	534	620	20-Φ26	585	4	32	670
DN600	634	725	20-Φ30	685	5	36	780
DN700	723	840	24-Φ30	800	5	40	895
DN800	823	950	24-Φ33	905	5	44	1015
DN900	923	1050	28-Φ33	1005	5	46	1115
DN1000	1023	1160	28-Φ36	1110	5	50	1230

Single Sphere Connector With Flange

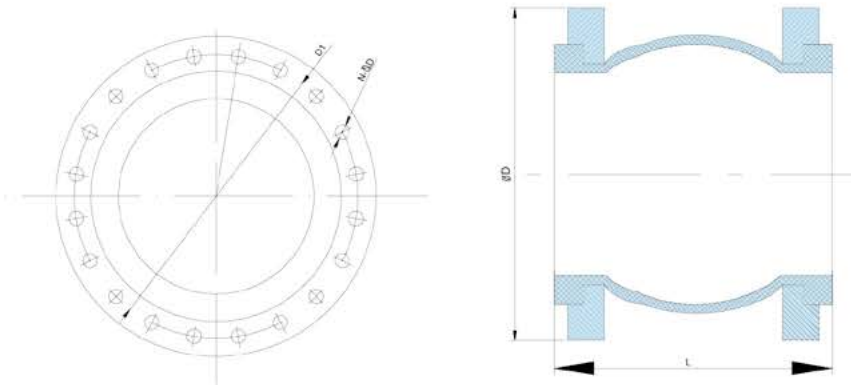

SIZE		L	DIN PN10		
IN	DN		D	D1	n-Ød
1 1/4	32	95	140	100	4-18
1 1/2	40	95	150	110	4-18
2	50	105	165	125	4-18
2 1/2	65	115	185	145	4-18
3	80	135	200	160	4-18
4	100	150	220	180	8-18
5	125	165	250	210	8-18
6	150	180	285	240	8-23
8	200	210	340	295	8-23
10	250	230	395	350	12-23
12	300	245	445	400	12-23
14	350	255	505	460	16-23
16	400	255	565	515	16-27
18	450	255	615	565	20-27
20	500	255	670	620	20-27
24	600	260	780	725	20-30

SIZE		L	DIN PN16		
IN	DN		D	D1	n-Ød
1 1/4	32	95	140	100	4-18
1 1/2	40	95	150	110	4-18
2	50	105	165	125	4-18
2 1/2	65	115	185	145	4-18
3	80	135	200	160	8-18
4	100	150	220	180	8-18
5	125	165	250	210	8-18
6	150	180	285	240	8-23
8	200	210	340	295	12-23
10	250	230	405	355	12-27
12	300	245	460	410	12-27
14	350	255	520	470	16-27
16	400	255	580	525	16-30
18	450	255	640	585	20-30
20	500	255	715	650	20-33
24	600	260	840	770	20-36

Working Pressure(Mpa)	1.6
Bursting Pressure(Mpa)	3
Angle of Deflection	15°
Vacuity Kpa(mmHg)	86.7(650)
Applicable Temp	-15~115℃
Applicable Media	Air, Compressed, Water, Weak Acid, Alkali, etc





Twin Sphere Connector With Thread

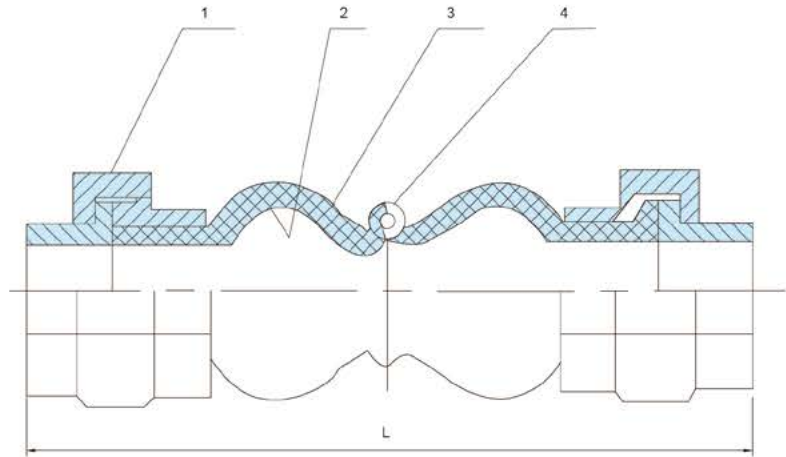

Working Pressure(Mpa)	1.6
Bursting Pressure(Mpa)	3
Angle of Deflection	15°
Vacuity Kpa(mmHg)	86.7(650)
Applicable Temp	-15~115℃
Applicable Media	Air, Compressed, Water, Weak Acid, Alkali, etc

STANDARD MATERIALS OF MAIN PARTS

ITEM	PART NAME	MATERIAL
1	Joint	Cast Iron
2	liner	NBR
3	Frame	Stainless
4	Steel Wire	CS

DIMENSIONS

SIZE		L	Axial displacement		Lateral displacement
IN	DN		stretch	compression	
1/2	15	180	5~6	22	22
3/4	20	180	5~6	22	22
1	25	180	5~6	22	22
1 1/4	32	200	5~6	22	22
1 1/2	40	210	5~6	22	22
2	50	220	5~6	22	22
2 1/2	65	245	5~6	22	22



Ball Valve

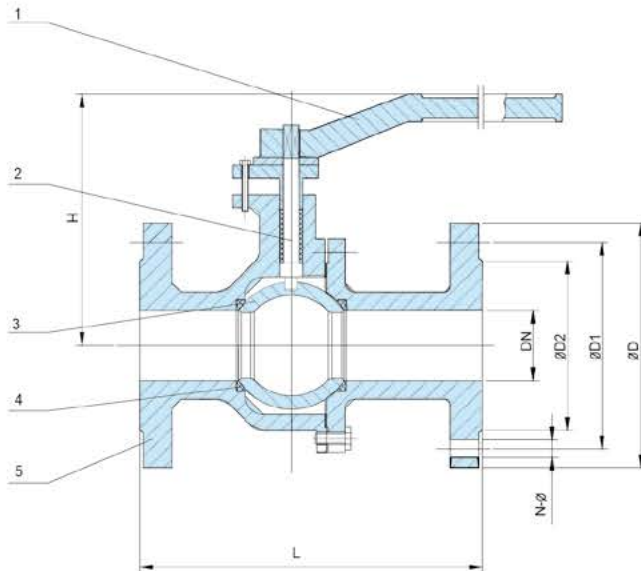

STANDRD MATERIALS OF MAIN PARTS

NO.	PART NAME	MATERIAL
1	Handle	Cast Iron, Ductile Iron
2	Stem	Carbon Steel, Stainless Steel
3	Ball	Cast Iron, Ductile Iron
4	Seal Ring	PTFE
5	Body	Cast Iron, Ductile Iron

DIMENSIONS Ball Valve

DN	D	L	H	D2	D1	N-Ø
20	105	150	98	55	75	4-14
25	115	160	103	65	85	4-14
32	135	165	103	78	100	4-18
40	145	180	123	85	110	4-18
50	160	203	130	100	125	4-18
65	180	222	145	120	145	4-18
80	195	241	178	135	160	8-18
100	215	305	189	155	180	8-18
125	245	356	226	185	210	8-18
150	280	394	237	210	240	8-23
200	335	457	370	265	295	8-23

DIMENSION TABLE

DN	1/2	3/4	1	1 1/4	1 1/2	2	2 1/2	3	4
L	80	80	84	93	106	108	112	127	140
B	65	75	85	100	110	125	145	160	180(190)
H	70	75.5	80	93	96	105.5	129	129	151
D	160	160	175	175	185	185	185	185	229
n-Ø	4-Φ14				4-Φ18		(4-Φ18) 8-Φ18	(8-Φ18)	(8-Φ18) 8-Φ22



- 1. two-slice construction, load-bearing blowout prevention stem, full-bore design, reduced resistance of fluid.
- 2. The surface and internal of valve body are with epoxy resin coating layer.
- 3. Stainless steel stem ensure its operation will not be affected by side thrust caused by high-pressure fluid.
- 4. Stainless steel valve ball reduced parts galling and prolonged service life.
- 5. PTFE valve seat, adjustable packing nut.
- 6. two-slice construction permits easy repairing; PTFE valve seat and PTFE packing rod, after removal of valve bonnet assemblies, can be repaired rapidly. Minor seat damage can be removed by lapping.





- Available Medium: Water
- Working Temperature: ≤150°C
- Flange Dimensions: DIN2532/2533



Foot Valve (DIN PN16)

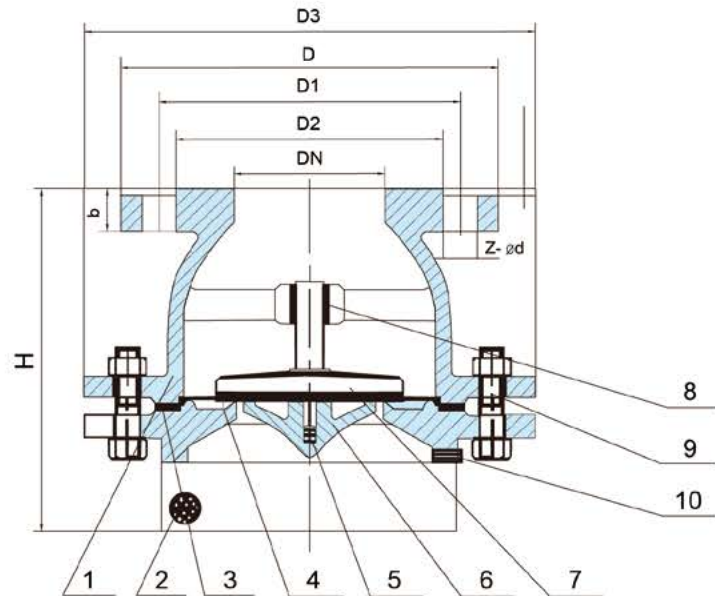

DETAILS

ITEM	PARTS NAME	MATERIAL
1	Body	Cast Iron
2	Screen	Stainless Steel
3	Gasket	Graphite
4	Flange Plate	Cast Iron
5	Stud Bolt	Carbon Steel
6	Lock Block	Cast Iron
7	Disc	Cast Iron+Rubber
8	Valve Guide	Brass
9	Bolt Nut	Carbon
10	Screw	Carbon

DN	D	D1	D2	D3	b	Z-φd	f	H	KG
40	150	110	88	170	18	4-18	3	137	
50	165	125	102	180	20	4-18	3	157	9.6
65	185	145	122	200	20	4-18	3	172	11.9
80	200	160	138	240	22	8-18	3	186	15.6
100	220	180	158	270	22	8-18	3	245	21.6
125	250	210	188	310	24	8-18	3	263	28.5
150	285	240	212	360	24	8-23	3	343	42.8
200	340	295	268	440	26	12-23	3	421	65.3
250	405	355	320	520	28	12-27	3	469	83.3
300	460	410	378	590	28	12-27	4	609	129.2
350	520	470	438	620	30	16-27	4	785	148.2

Dismantling Joint

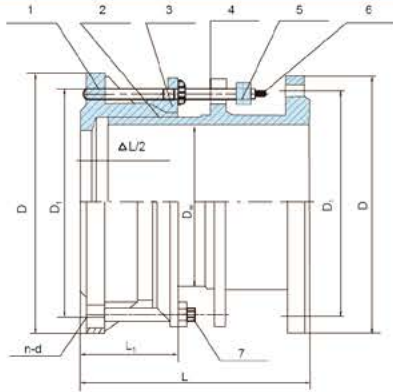

No	Name	Quantity	Material
1	Body	1	QT400-15,Q235A,ZG230-450,20
2	Gasket	1	NBR
3	Cover	1	QT400-15,Q235A,ZG230-450,20
4	Limited short pipe	1	Q234A,20,16Mn
5	Nut	4n	Q235A,20,1Cr18Ni9Ti
6	Long Stud	n	Q235A,35,1Cr18Ni9Ti
7	bolt	n	Q235A,35,1Cr18Ni9Ti

THE SIZE MEETS STANDARD GB/T12456-2002

Nominal diameter DN	External diameter of pipe DW	Length L	Compensation ΔL L1	D	D1	Flange connecting dimension				
						0.6Mpa		1.0Mpa		
						n-do	D	D1	n-do	
65	76	340	105	50	160	130	4- Φ 14	185	145	4- Φ 18
80	89				190	150	4- Φ 18	200	160	8- Φ 18
100	108				210	170	220	180		
125	133				240	200	8- Φ 18	250	210	8- Φ 18
150	159				265	225	8- Φ 18	285	240	8- Φ 22
200	219	350	130	65	3211	280		340	295	
250	273				375	335	12- Φ 18	395	350	12- Φ 22
300	325				440	395	12- Φ 22	445	400	
350	377				490	445		505	460	16- Φ 22
400	426				540	495	16- Φ 22	565	515	16- Φ 26
450	480	590	220	130	595	550		615	565	
500	530				645	600	20- Φ 22	670	620	20- Φ 26
600	630				755	705	20- Φ 26	780	725	20- Φ 30
700	720				860	810	24- Φ 26	895	840	24- Φ 30
800	820				95	920	24- Φ 30	1015	950	24- Φ 33
900	920	600	240	140	1075	1020		1115	1050	28- Φ 33
1000	1020				1175	1120	28- Φ 30	1230	1160	28- Φ 36
1200	1220				1405	1340	32- Φ 33	1455	1380	32- Φ 40
1400	1420				1630	1500		1675	1590	36- Φ 42
1500	1520				1730	1660	36- Φ 36			
1600	1620	600	240	140	1830	S	40- Φ 36	1915	1820	40- Φ 48
1810	1820				2045	1970	44- Φ 40	2115	2020	44- Φ 48
2000	2020				2265	2180	48- Φ 42	2325	2230	48- Φ 48
2200	2220				2475	2390	52- Φ 42	2550	2440	52- Φ 56
2400	2420				2685	2600	56- Φ 42	2760	2650	60- Φ 56
2600	2620	600	240	140	2905	2810	60- Φ 48	2960	3070	64- Φ 56
2800	2820				3115	3020	64- Φ 48	3180	3290	68- Φ 60
3000	3020				3315	3220	68- Φ 48	3405		
3200	3220				3525	3430	72- Φ 48			
3400	3420				3735	3640	76- Φ 48			
3600	3620	3970	3860	80- Φ 56						

GB/T12456-2002 Note: The size meets standard GB/T12456-2002



- Ductile Iron GGG50,GJS500-7,GGG40
- Size: DN50-DN2000
- Bolts and Nuts: Galvanized Steel / Zinc Plated Steel
- Pressure: PN10/16/25



