



USER MANUAL

Hybrid Inverter User Manual

CONTENTS

1 NOTES ON THIS MANUAL	2
1.1 SCOPE OF VALIDITY	2
1.2 TARGET GROUP	2
1.3 SYMBOLS USED	2
2 SAFETY	3
2.1 IMPORTANT SAFETY INSTRUCTIONS	3
2.2 EXPLANATION OF SYMBOL	6
3. INTRODUCTION	8
3.1 BASIC FEATURES.....	8
3.2 SYSTEM DIAGRAM	8
3.3 WORK MODES.....	11
3.4 DIMENSION	12
3.5 TERMINALS OF PV INVERTER	13
4. TECHNICAL PARAMETERS	14
4.1 INVERTER SPECICATION	14
5. INSTALLATION	16
5.1 CHECK FOR PHYSICAL DAMAGE	16
5.2 PACKING LIST.....	16
5.3 MOUNTING	17
6. ELECTRICAL CONNECTION	19
6.1 PV CONNECTION	19
6.2 GRID CONNECTION (GEN CONNECTION).....	21
6.3 BACK-UP:LOAD1 AND LOAD2 CONNECTION.....	21
6.4 BATTERY CONNECTION	23
6.6 METER CONNECTION	25
6.7 WIFI CONNECTION (OPTIONAL).....	26
6.8 GPRS CONNECTION (OPTIONAL).....	27
7. LCD OPERATION	28
7.1 CONTROL PANEL	28
7.2 INSTRUCTIONS FOR LED INDICATOR.....	28
7.3 INSTRUCTIONS FOR THE USE OF THREE MODES	29
8. FAULT DIAGNOSIS AND SOLUTIONS	31

1 Notes on this Manual

1.1 Scope of Validity

This manual is an integral part of Hybrid, It describes the assembly, installation, commissioning, maintenance and failure type of the product. Please read it carefully before operating.

GSL-H-5KLV-US	GSL-H-6KLV-US	GSL-H-7.6KLV-US	GSL-H-8KLV-US
---------------	---------------	-----------------	---------------

Naming rules, For example: GSL-H-8KLV-US

“H” means “ means Hybrid On off Grid ”

“8K” means “ output Power 8kw ”

“US” means “ USA version split phase ”

“LV” means “ Lov Voltage 48VDC Battery system ”

Store this manual where it will be accessible at all times.

1.2 Target Group

This manual is for qualified electricians. The tasks described in this manual only can be performed by qualified electricians.

1.3 Symbols Used

The following types of safety instructions and general information appear in this document as described below:

	Danger ! “Danger” indicates a hazardous situation which, if not avoided, will result in death or serious injury.
---	--

	Warning! “Warning” indicates a hazardous situation which, if not avoided, could result in death or serious injury.
---	--

	Caution ! “Caution” indicates a hazardous situation which, if not avoided, could result in minor or moderate injury.
---	--

	Note ! “Note” provides tips that are valuable for the optimal operation of our
---	--

2 Safety

2.1 Important Safety Instructions



Danger!

- Danger to life due to high voltages in the inverter!
- All work must be carried out by qualified electrician.
- The appliance is not to be used by children or persons with reduced physical sensory or mental capabilities, or lack of experience and knowledge, unless they have been given supervision or instruction.
- Children should be supervised to ensure that they do not play with the appliance.



Caution!

- Danger of burn injuries due to hot enclosure parts!
- During operation, the upper lid of the enclosure and the enclosure body may become hot.
- Only touch the lower enclosure lid during operation



Caution!

- Possible damage to health as a result of the effects of radiation!
- Do not stay closer than 20 cm to inverter for any length of time.



Note!

- Grounding the PV generator
- Comply with the local requirements for grounding the PV modules and the PV generator. It is recommended connecting the generator frame and other electrically conductive surfaces in a manner which ensures continuous conduction and ground these in order to have optimal protection of system and persons



Warning!

- Ensure input DC voltage \leq Max. DC voltage .Over voltage may cause Permanent damage to inverter or other losses, which will not be included in warranty!



Warning !

- Authorized service personnel must disconnect both AC and DC power from inverter before attempting any maintenance or cleaning or working on any circuits connected to inverter.



Warning!

- Do not operate the inverter when the device is running .



Warning !

- Risk of electric shock!

- Please keep the user manual properly. When operating equipment, in addition to following the general precautions in this document, follow the specific safety instructions . We will not be liable for any consequence caused by the violation of the safety operation regulations and design, production, and usage standards.
- Accessories only together with the inverter shipment are recommended here. Other- wise may result in a risk of fire, electric shock, or injury to person.
- Make sure that existing wiring is in good condition and that wire is not undersized. Do not disassemble any parts of inverter which are not mentioned in installation guide. It contains no user-serviceable parts. See Warranty for instructions on obtaining service. Attempting to service the inverter yourself may result in a risk of electric shock or fire and will void your warranty.
- Keep away from flammable, explosive materials to avoid fire disaster.
- The installation place should be away from humid or corrosive substance.
- Authorized service personnel must use insulated tools when installing or working with this equipment.
- Never touch either the positive or negative pole of PV connecting device. Strictly prohibit touching both of them at the same time.
- The unit contains capacitors that remain charged to a potentially lethal voltage after the MAINS , battery and PV supply has been disconnected.
- Hazardous voltage will present for up to 5 minutes after disconnection from power supply.
- CAUTION-RISK of electric shock from energy stored in capacitor, Never operate on the inverter couplers, the MAINS cables, Battery cables, PV cables or the PV generator when power is applied. After switching off the PV , battery and Mains, always wait for 5minutes to let the intermediate circuit capacitors discharge before unplugging DC ,battery in plug and MAINS couplers.

-
- When accessing the internal circuit of inverter, it is very important to wait 5 minutes before operating the power circuit or demounting the electrolyte capacitors inside the device. Do not open the device before hand since the capacitors require time sufficiently discharge!
 - Surge protection devices (SPDs) for PV installation



WARNING !

Over-voltage protection with surge arresters should be provided when the PV power system is installed.

The grid connected inverter is not fitted with SPDs in both PV input side and MAINS side.

- Lightning will cause a damage either from a direct strike or from surges due to a nearby strike.
 - Induced surges are the most likely cause of lightning damage in majority of installations, especially in rural areas where electricity is usually provided by long overhead lines. Surge may be included on both the PV array conduction and the AC cables leading to the building.
 - Specialists in lightning protection should be consulted during the end use application. Using appropriate external lightning protection, the effect of a direct lightning strike into a building can be mitigated in a controlled way, and the lightning current can be discharged into the ground.
 - Installation of SPDs to protect the inverter against mechanical damage and excessive stress include a surge arrester in case of a building with external lightning protection system (LPS) when separation distance is kept.
 - To protect the DC system, surge suppression device (SPD type2) should be fitted at the inverter end of the DC cabling and at the array located between the inverter and the PV generator, if the voltage protection level (VP) of the surge arresters is greater than 1100V, an additional SPD type 3 required for surge protection for electrical devices.
 - To protect the AC system, surge suppression devices (SPD type2) should be fitted at the main incoming point of AC supply (at the consumers cutout), located between the inverter and the meter/distribution system;
 - All DC cables should be installed to provide as short a run as possible, and positive and negative cables of the string or main DC supply should be bundled together. Avoiding the creation of loops in the system.
 - Spark gap devices are not suitable to be used in DC circuits once conducting, they won't stop conducting until the voltage across their terminals is typically more than 30 volts.
- Anti-Islanding Effect

Islanding effect is a special phenomenon that grid-connected PV system still supply power to the nearby grid when the voltage loss is happened in the power system. It is dangerous for maintenance personnel and the public.

Hybrid series inverter provide Active Frequency Drift(AFD) to prevent islanding effect.

➤ PE Connection and Leakage Current

•The end-use application shall monitor the protective conductor by residual current operated protective device (RCD) with rated fault current $I_{fn} \leq 240\text{mA}$ which automatically disconnects the device in case of a fault.

The device is intended to connect to a PV generator with a capacitance limit of approx 700nf.

	<p>WARNING ! High leakage current! Earth connection essential before connecting supply.</p>
---	--

Incorrect grounding can cause physical injury, death or equipment malfunction and increase electromagnetic.

➤ Battery Safety Instructions

Hybrid Series inverter should be worked with high voltage battery, for the specific parameters such as battery type, nominal voltage and nominal capacity etc., please refer to section 4.3.

As accumulator batteries may contain potential electric shock and short-circuit current danger, to avoid accidents that might be thus resulted, the following warnings should be observed during battery replacement:











- 1: Do not wear watches, rings or similar metallic items.
- 2: Use insulated tools.
- 3: Put on rubber shoes and gloves.
- 4: Do not place metallic tools and similar metallic parts on the batteries.
- 5: Switch off load connected to the batteries before dismantling battery connection terminals.
- 6: Only personal with proper expertise can carry out the maintenance of accumulator batteries.

2.2 Explanation of Symbol

This section gives an explanation of all the symbols shown on the inverter and on the type label.

Symbols on the Type Label

	CSA certified
---	---------------

	This symbol indicates that you should wait at least 5mins after disconnecting the inverter from the utility grid and from the PV panel before touching any inner live parts.
	Keep dry! The package/product must be protected from excessive humidity and must be stored under cover.
	Refer to the operating instructions.
	Fragile - The package/product should be handled carefully and never be tipped over or slung.
	Products should not be disposed as household waste.
	No more than six(6) identical packages being stacked on each other
	Components of the product can be recycled.
	Danger of hot surface!
	Danger of high voltage and electric shock!
	Caution! Failure to observe a warning indicated in this manual may result in injury

3. Introduction

3.1 Basic features

Hybrid Series is a high-quality inverter which can convert solar energy to AC energy and store energy into battery.

The inverter can be used to optimize self-consumption, store in the battery for future use or feed in to public grid. Work mode depends on PV energy and user' s preference. It can provide power for emergency use during the grid lost by using the energy from battery and inverter (generated from PV).

3.2 System Diagram

Hybrid Series is designed with two BACK-UP versions for customer to choose based on the local rules. The applies to the wiring rules that requires Neutral line of alternative supply must NOT be isolated or switched .



Note!

Please control the home loads, and make sure it' s within the "BACK-UP output rating" under BACK-UP mode, otherwise the inverter will shut down with an "overload fault" warning.

Please confirm with the mains grid operator whether there is any special regulations for grid connection.

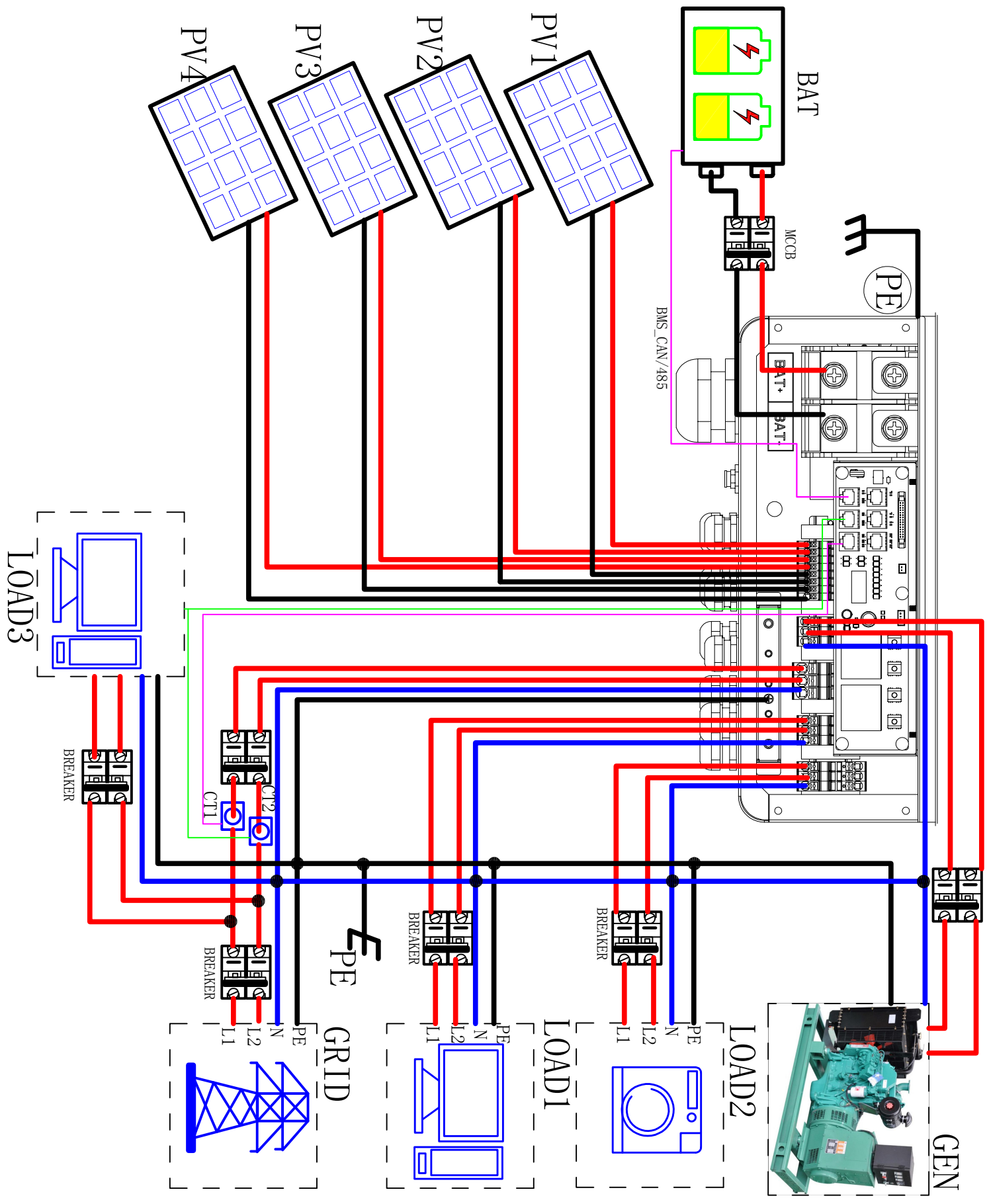

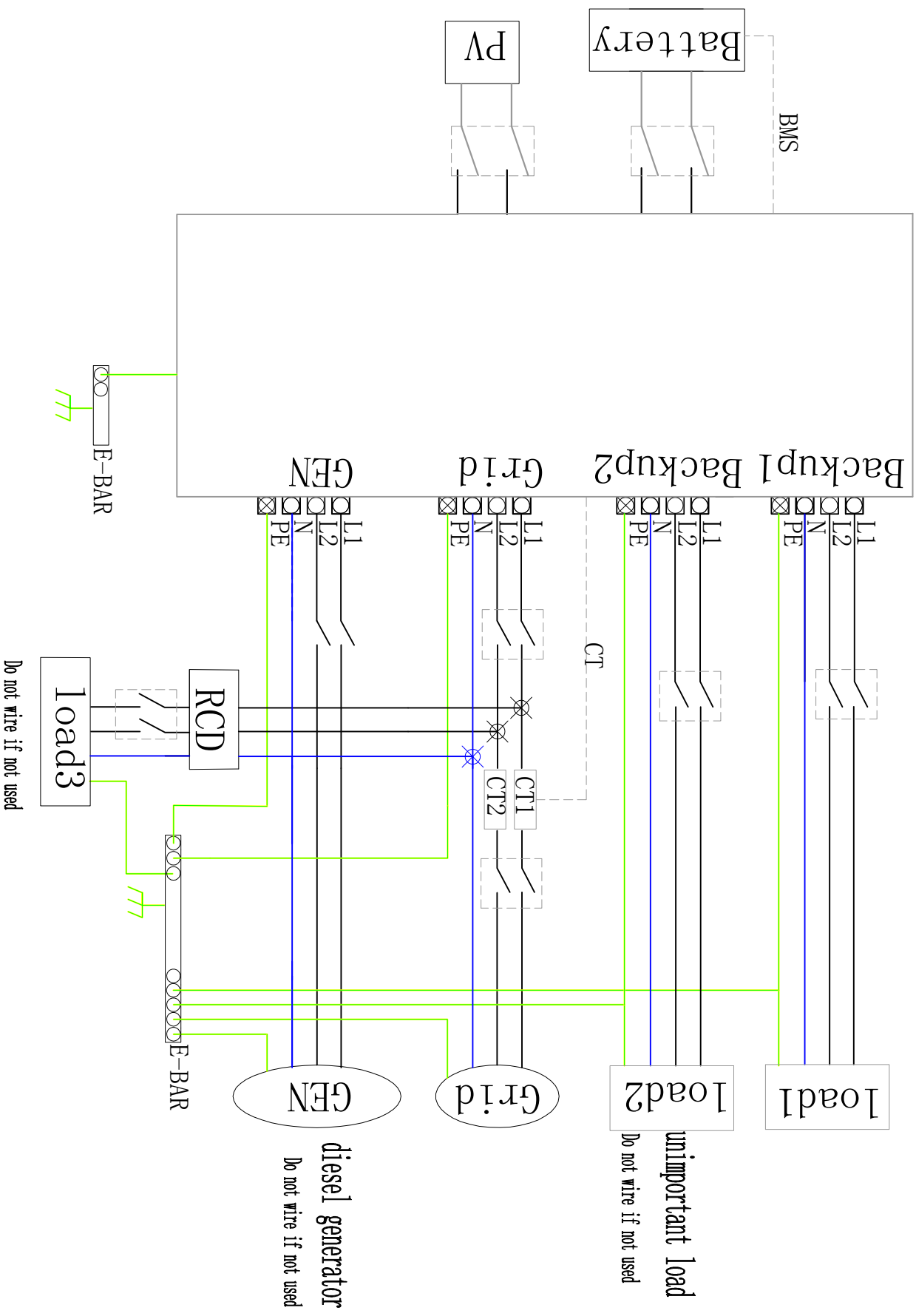

3.3 Work Modes

Inverter provides multiple work modes based on different requirements.

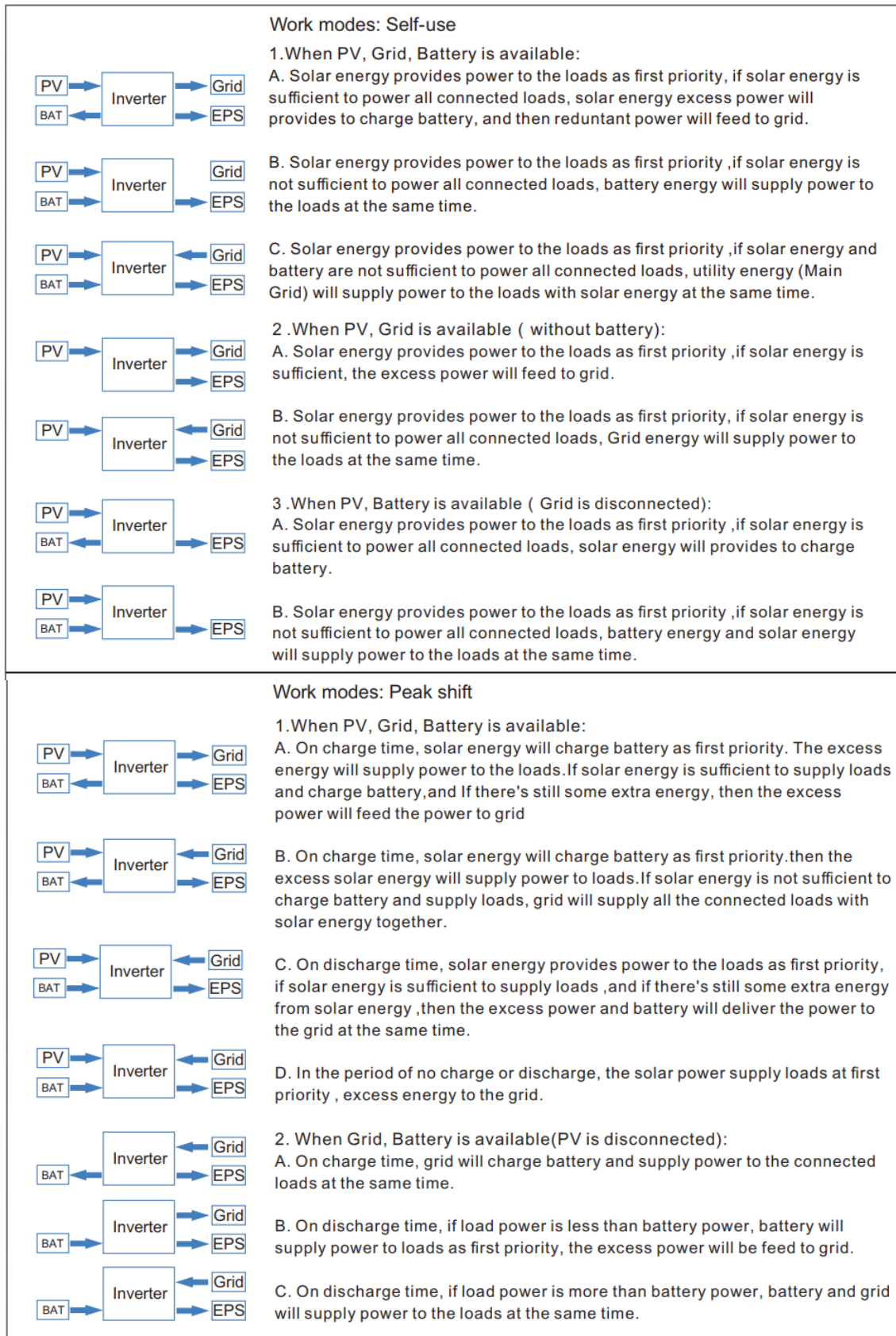

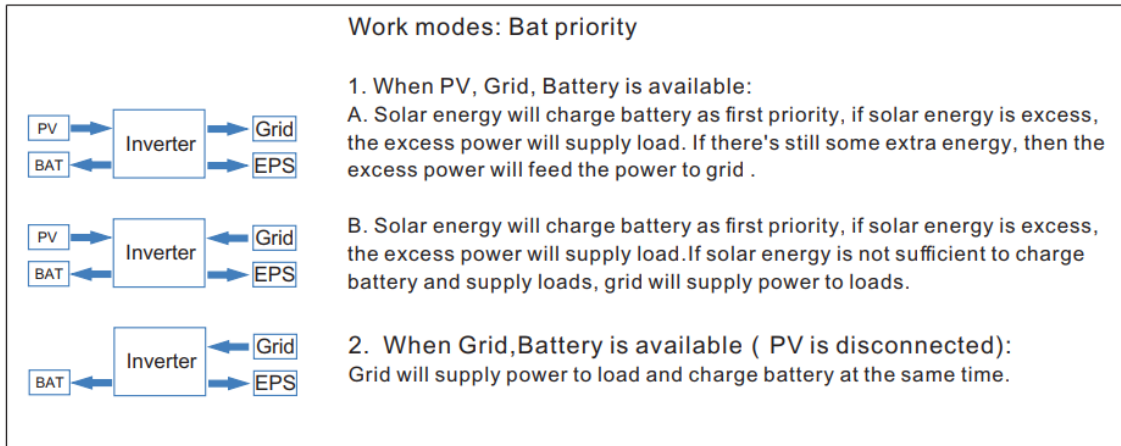

Note!

If set anti-Reverse function allowable, Once on the work mode of Self-use, Peak shift, battery priority, the system will not feed power to grid.

3.4 Dimension

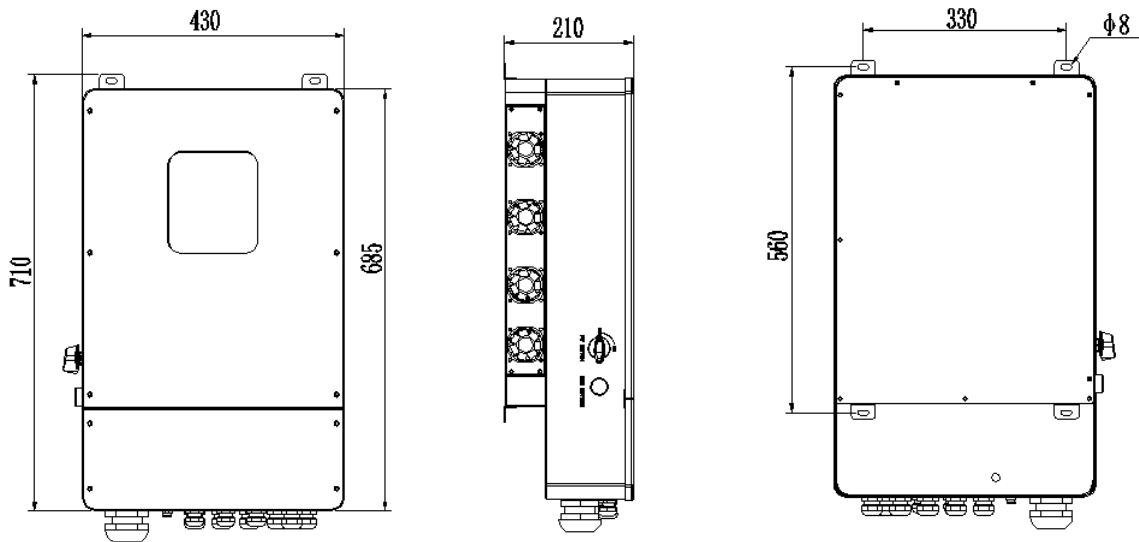

3.5 Terminals of PV inverter

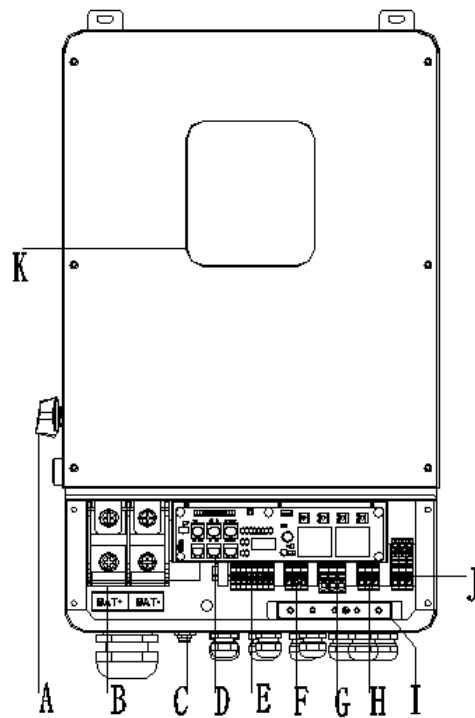

Object	Description
A	DC switch
B	BAT input
C	WiFi
D	DRM/BMS/CT/DRY IO/CAN/USB upgrading
E	PV1~PV4 input
F	Generator
G	Grid
H	BACK-UP1 output
I	PE
J	BACK-UP2 output
K	LCD



WARNING !

Qualified electrician will be required for the installation.

4. Technical Parameters

4.1 Inverter specification

Technical Data	GSL-H-5KLV-US	GSL-H-6KLV-US	GSL-H-7.6KLV-US	GSL-H-8KLV-US
PV Input Data				
MAX.DC Input Power	7.5kW	9kw	12kw	12KW
NO.MPPT Tracker	4			
MPPT Range	120 – 500V			
MAX.DC Input Voltage	500V			
MAX.Input Current	12A			
Battery Input Data				
Nominal voltage (Vdc)	48V	48V	48V	48V
MAX.Charging/Discharging Current	120A/120A	135A/135A	190A/190A	190A/190A
Battery Voltage Range	85–400V			
Battery Type	Lithium and Lead Acid Battery			
Charging Strategy for Li-Ion Battery	Self-adaption to BMS			
AC Output Data(On-Grid)				
Nominal output power Output to Grid	5KVA	6KVA	7.6KVA	8KVA
MAX. Apparent Power Output to Grid	5.5KVA	6.6KVA	8.4KVA	8.8KVA
Output Voltage Range	110–120/220–240V split phase, 1Ø, 230 1 phase			
Output Frequency	50/60Hz (45 to 54.9Hz / 55 to 65Hz)			
Nominal AC Current Output to Grid	21.7A	26A	33A	34.8A
Max.AC Current Output to Grid	24A	28.8A	36.5A	38.3A
Max.AC Current From Grid	35A	35A	50A	50A
Output Power Factor	0.8leading…0.8lagging			
OutPut THDI	< 2%			
AC Output Data(Back-Up)				
Nominal. Apparent Power Output	5KVA	6KVA	7.6KVA	8KVA
MAX. Apparent Power Output	5.5KVA	6.6KVA	8.4KVA	8.8KVA
Nominal Output Voltage L–N/L1–L2	120/240V			
Nominal Output Frequency	60Hz			
Output THDU	< 2%			
Efficiency				
Europe Efficiency	≥97.8%			
MAX. Battery to Load Efficiency	≥97.2%			
Protection				
Grounding detection	YES			
Arc Fault Protection	YES			
Island Protection	YES			

Battery reverse Polarity	YES
Insulation Resistor Detection	YES
Residual Current Monitoring Unit	YES
Output Over Current Protection	YES
Back-up Output Short Protection	YES
Terminal temperature detection	YES
Output Over Voltage Protection	YES
Output Under Voltage Protection	YES
General Data	
Output Conduit	25.4mm
PV Input Conduit	25.4mm
BAT Input Conduit	34.5mm
Operating Temperature Range	-.25 ~ +60°C
Relative Humidity	0-95%
Operating Altitude	0~4000m
Ingress Protection	IP65/NEMA 3R
Weight	32kg
Size (Width*Height*Depth)	530mm x 660mm x 200mm
Cooling	Natural Convection
Noise emission	<38dB
Display	LCD
Communication With BMS/Meter/EMS	RS485, CAN
Supported communication interface	RS485, WLAN, 4G (optional)
Self-consumption at night	< 2.5 W (with battery enabling < 5 W)
Safety	UL1741SA all options, UL1699B, CSA 22.2
EMC	FCC Part 15 Class
Grid connection standards	IEEE 1547, IEEE 2030.5, Hawaii Rule 14H, Rule 21 Phase I,II,III

5. Installation

5.1 Check for Physical Damage

Make sure the inverter is intact during transportation. If there is any visible damage, such as cracks, please contact your dealer immediately.

5.2 Packing List

Open the package and take out the product, please check the accessoires first. The packing list shown as below.

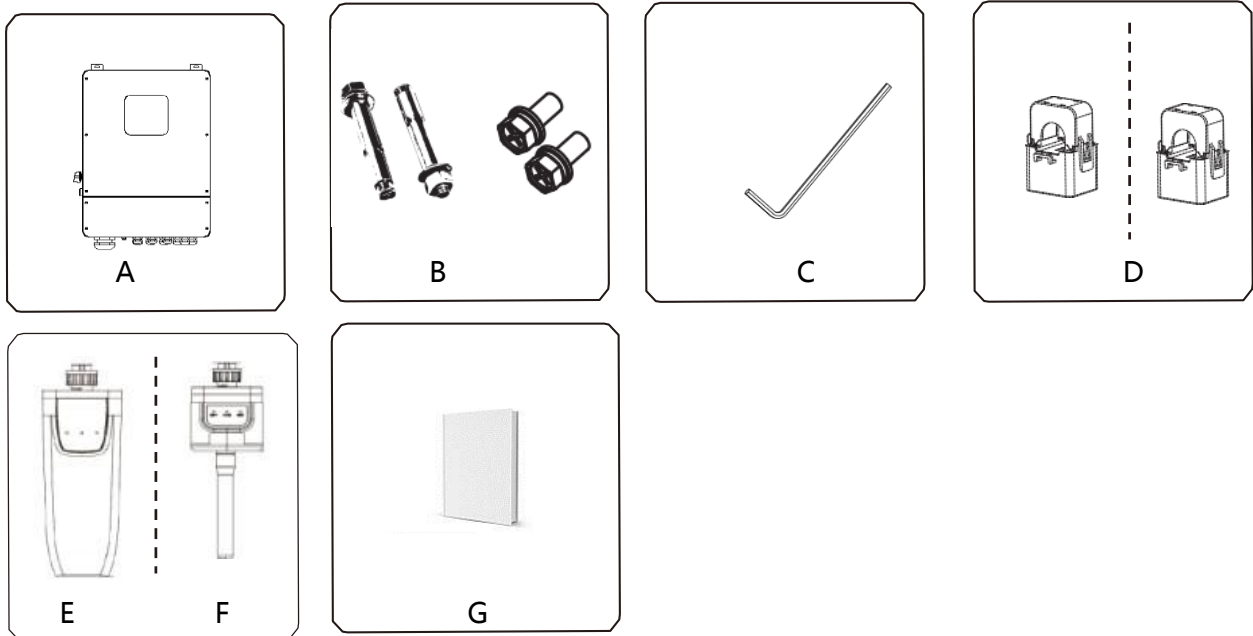

Object	Description
A	Inverter
B	Expansion screws and pan-head screws
C	Allen Wrench
D	CT
E	WiFi module (optional)
F	GPRS module (optional)
G	User manual

5.3 Mounting

➤ Installation Precaution

Inverter is designed for outdoor installation (IP 65). Make sure the installation site meets the following conditions:

- ◆ Not in direct sunlight.
- ◆ Not in areas where highly Flammable materials are stored.
- ◆ Not in potential explosive areas.
- ◆ Not in the cool air directly.
- ◆ Not near the television antenna or antenna cable.
- ◆ Not higher than altitude of about 2000m above sea level.
- ◆ Not in environment of precipitation or humidity (> 95%).
- ◆ Under good ventilation condition.
- ◆ The ambient temperature in the range of -20°C to +60°C.
- ◆ The slope of the wall should be within $\pm 5^\circ$.
- ◆ The wall hanging the inverter should meet conditions below:

1. solid brick/concrete, or strength equivalent mounting surface;

2. Inverter must be supported or strengthened if the wall's strength isn't enough (such as wooden wall, the wall covered by thick layer of decoration)

Please AVOID direct sunlight, rain exposure, snow laying up during installation and operation.

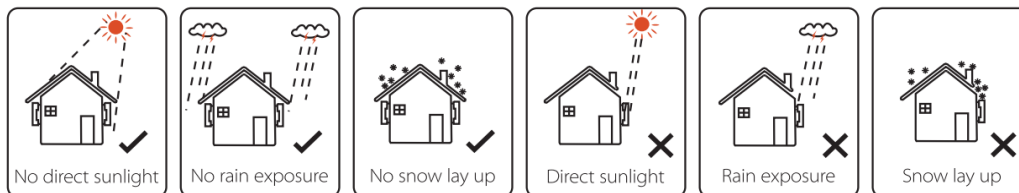

➤ **Space Requirement**

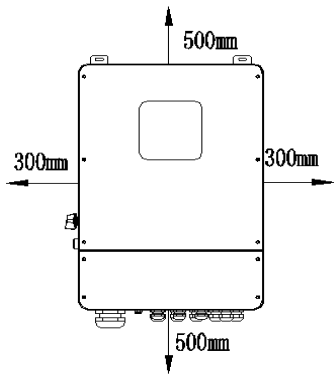

Position	Min.size
Left	300mm
Right	300mm
Top	500mm
Bottom	500mm
Front	1000mm

➤ **Mounting**

Tools required for installation.

Installation tools : crimping pliers for binding post and RJ45, screwdriver, manual wrench etc



Step 1: Drill 4 holes in the wall according to the following distance dimensions, 50~60mm depth. Then use a proper hammer to fit the expansion bolt into the holes.

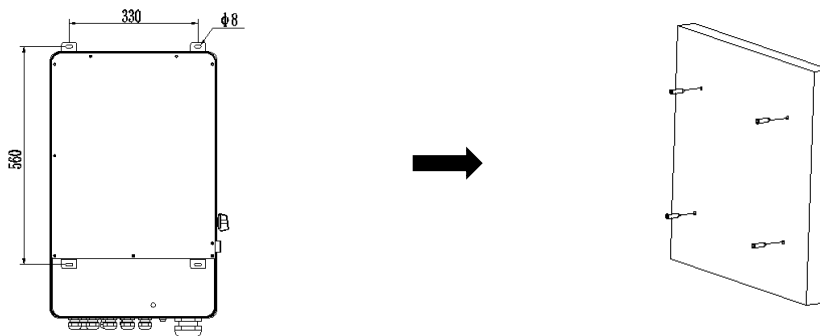

Step 2: Lift up the inverter and align the hole of the inverter with the expansion bolt, Fix the inverter on the wall.

Step 3: Tighten the nut of expansion bolt , and install an anti-theft lock on DC switch of the inverter

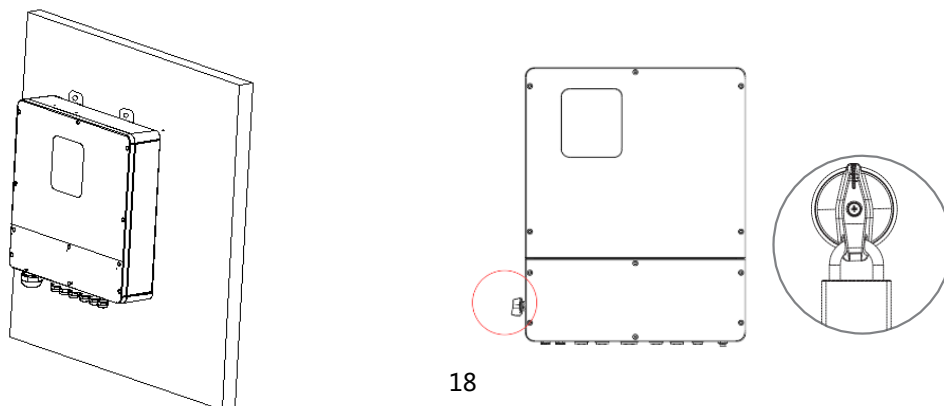

Step 4: Remove the cover screws by Allen Wrench and remove the cover. Remove the waterproof cover by a flat blade screwdriver. Wiring box conduit plugs, Conduit plugs are provided for 1 inch conduit fittings. If used conduit fitting is not 1 inch, an appropriate conduit adaptor should be used.

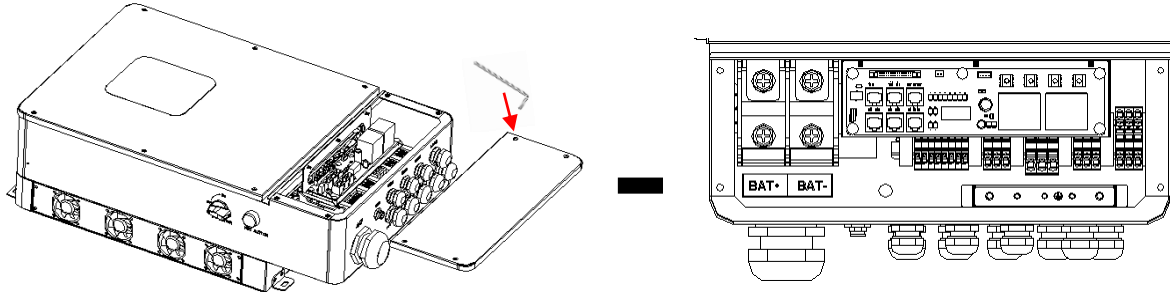

Step 5: Pass the corresponding conduit and fasten the joint.

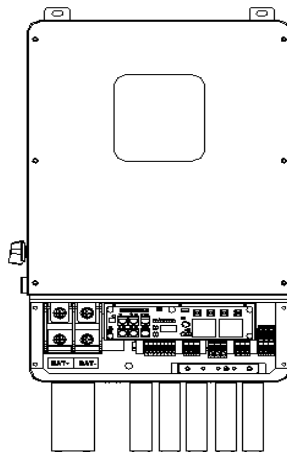

6. Electrical Connection

6.1 PV connection

Hybrid can be connected in series with 4-strings PV modules for 5kW, 6kW, 7.6kW, 8kW. Select PV modules with excellent function and reliable quality. Open-circuit voltage of module arrays connected in series should be <Max. DC input voltage; operating voltage should be conformed to MPPT voltage range.



Warning!

PV module voltage is very high, which already achieve dangerous voltage range, please comply with electric safety rules when connecting.

Please do not make PV positive or negative ground!



Note!

The following requirements of PV modules need to be applied for each input area;

Please do not make PV positive or negative ground!

In order to save cable and reduce the DC loss, we suggest to install the inverter near PV modules.

Step1. Wiring.

1.1 Choose the 12 AWG wire to connect with the cold-pressed terminal.

1.2 Remove 18mm of insulation from the end of wire.

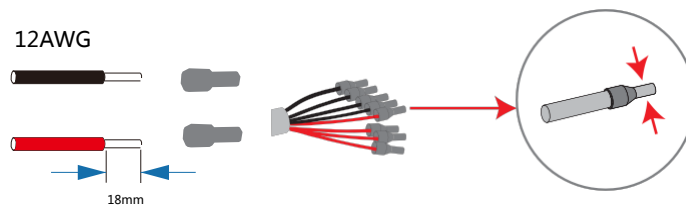

Step2. Cross the PV cables at through the PV port, Connect PV cables to PV terminals.

Connect PV cables to PV terminals.

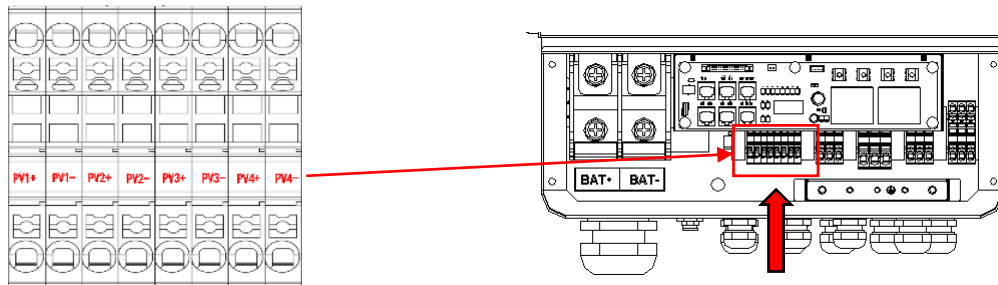

6.2 Grid Connection (GEN connection)

Step1. Check the grid voltage.

- 1.1 Check the grid voltage and compare with the permissive voltage range (Please refer to technical data).
- 1.2 Disconnect the circuit board from all the phases and secure against re-connection.

Step2. Grid cables choose

Use the right pin terminal from the accessory box. Press the connectors on cable conductor core tightly.

Model	GSL-H-5KLV-US	GSL-H-6KLV-US	GSL-H-7.6KLV-US	GSL-H-8KLV-US
Cable	12AWG		10AWG	

Step3. Choose the wire to connect with the cold-pressed terminal. (Remove 18mm of insulation from the end of wire.)

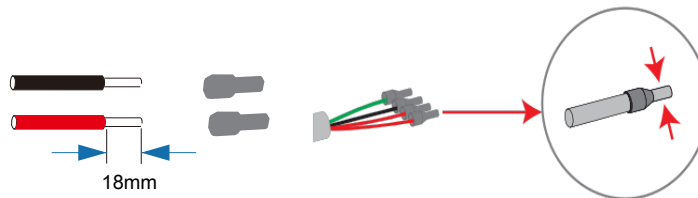

Step4. Cross the Grid cables although the grid port, Connect Grid cables to Grid terminals.

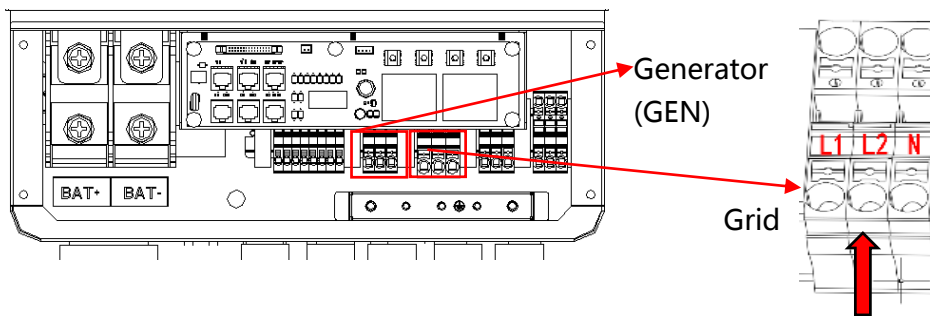

6.3 Back-up:Load1 and Load2 Connection

Inverter has On and Off grid function, the inverter will deliver output power through AC port when the grid is on, and it will deliver output power through back-up port when the the grid is off.

➤ Auto & Manual

BACK-UP function can be achieved automatically or manually according to user' s wishes. BACK-UP function can only be triggered automatically.

➤ Load1 port: important load.

Load2 port: When the battery is not sufficient, the load on this interface will power down

- 1).For inverter, the standard PV installation typically consists of the connection of the inverter with both panels and batteries. In case of systems not connected to the batteries, the Back-Up function is strongly not advised to use. It shall not cover the standard warranty and be liable for any consequences arising from users not following this instruction.
- 2) Hybrid inverters are able to supply over load output at its "Back-Up" . For details please refer to the technical parameters of inverter. And the inverter has self-protection dreading at high ambient temperature.
- 3) For complicated application, or Special load , please contact after-sales.

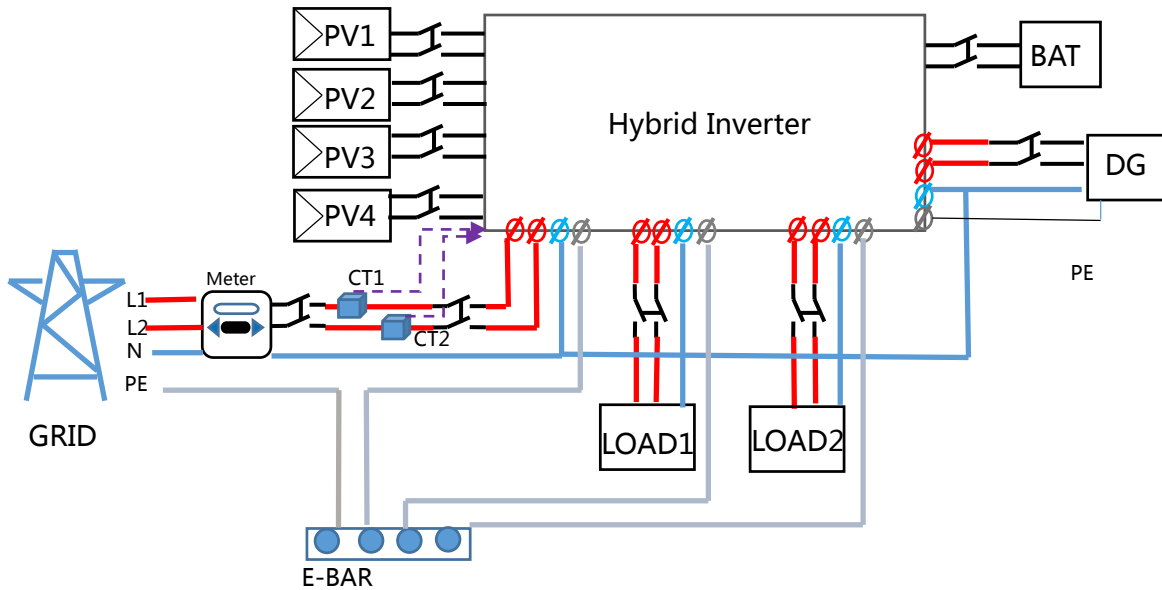

Note!

In case of discrepancies between wiring mode of local policy and the operation guide above, especially for the wiring of neutral line, grounding and RCD, please contact us before any operation!

➤ **Back-Up:Load1 and Load2 Connection:**

When using the off grid function, please add off grid AC breaker in off grid output cable to ensure safety.

Model	GSL-H-5KLV-US	GSL-H-6KLV-US	GSL-H-7.6KLV-US	GSL-H-8KLV-US
Micro-breaker	32A		40A	

Note: The absence of AC breaker on back-up side will lead to inverter damage if an electrical short circuit happens on back-up side.

Step1. Make BACK-UP wires.

Model	GSL-H-5KLV-US	GSL-H-6KLV-US	GSL-H-7.6KLV-US	GSL-H-8KLV-US
Cable	12AWG		10AWG	

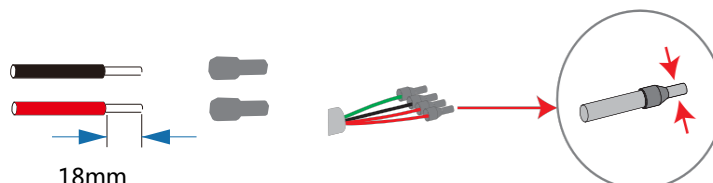

Step2. Connect the cables to the BACK-UP:Load1 and Load2 port of the inverter.

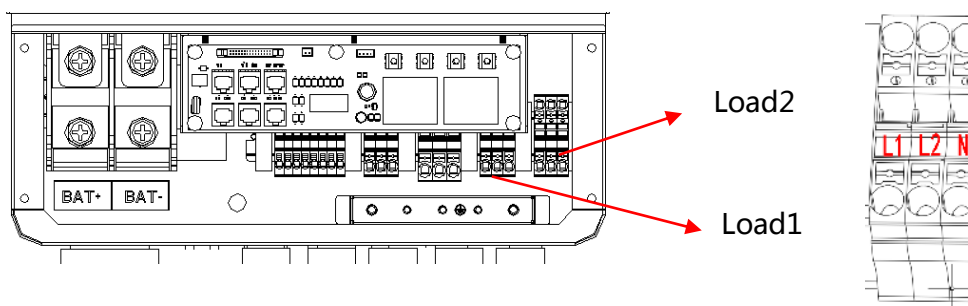

➤ Requirements for BACK-UP load

Warning!



Make sure the BACK-UP load power rating is within BACK-UP output rating, otherwise the inverter will shut down with an "over load" warning.

When an "over load" is appeared, adjust the load power to make sure it is within the BACK-UP output power range, then turn the inverter back on.

For the nonlinear load, please make sure the inrush power should be within the BACK-UP output power range.

6.4 Battery Connection

Charging & discharging system of Hybrid series inverter is designed for 48V lithium battery. Before choosing battery, please note the maximum voltage of battery can not exceed 60V and the battery communication should be compatible with Hybrid inverter.

➤ Battery breaker

Before connecting to battery, please install a no-polarized DC breaker to make sure inverter can be securely disconnected during maintenance.

Model	GSL-H-5KLV-US	GSL-H-6KLV-US	GSL-H-7.6KLV-US	GSL-H-8KLV-US
Current[A]	160A		250A	

➤ **Battery connection diagram**

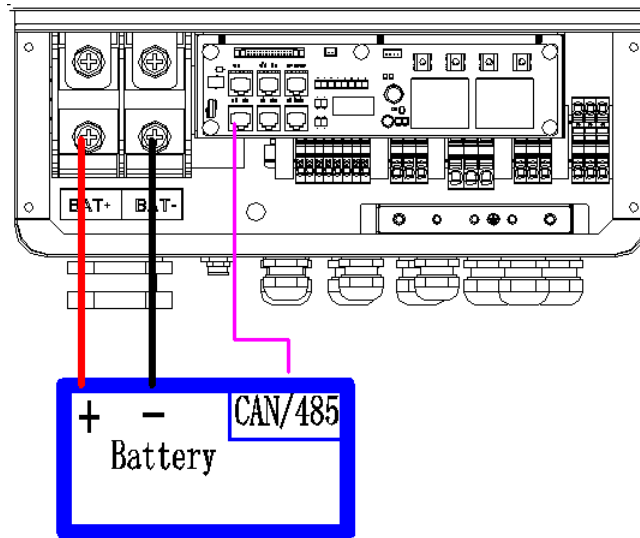

➤ **BMS PIN Definition**

Communication interface between inverter and battery is RS485 or CAN with a RJ45 connector.

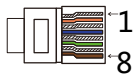

	PIN	1	2	3	4	5	6	7	8
CAN	Definition	X	X	X	BMS_CANH	BMS_CANL	X	X	X
RS485	Definition	X	X	X	X	X	GND	BMS_485A	BMS_485B

When using RS485 protocol, please note that PIN2 must be disconnected !

Note !



The battery communication can only work when the battery BMS is compatible with the inverter.

➤ **Power Connection Battery:**

Step1

Choose the 2 AWG wire and strip the cable to 15mm. Select two O-terminals with an aperture of M8. Insert the stripping line into the O-terminal and clamp it with a crimping clamp.

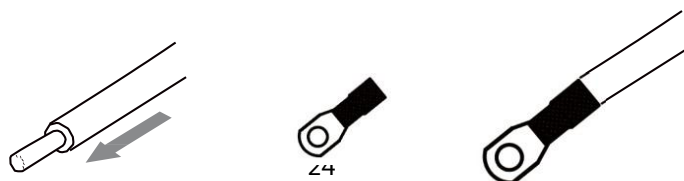

Step2. Cross the battery cable although the battery port. Connect battery cable to battery terminal

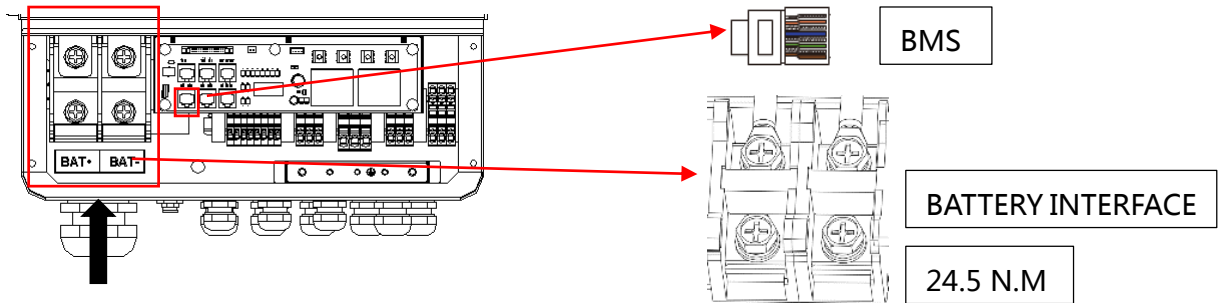

Note !

Positive and negative lines are not allowed to reverse.

6.6 Meter Connection

Meter is used for monitoring the power usage for entire house, at the meantime, inverter will also need the data from Meter to achieve the Export Control Function.



Note!

It is necessary to connect meter to inverter otherwise inverter will shutdown with a "Meter fault" alert.

The meter communication only works when meter is compatible with the inverter.

➤ Meter PIN Definition

Communication interface between inverter and meter is RS485 with a RJ45 connector.

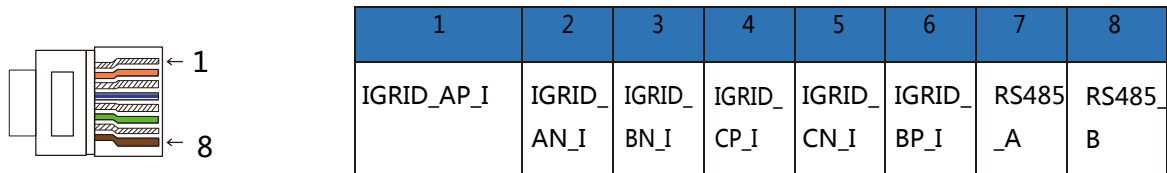

➤ Meter Connection :

Please refer to BMS connection for Meter connection. Please kindly noted the PIN definition and port position will be slightly different.

Step1. Make RJ45 wire, Cross the Meter wire although the com port.

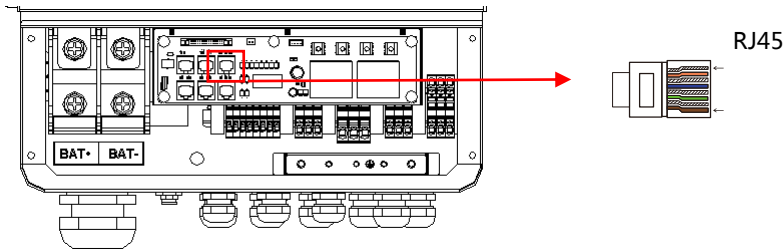

Step2. Insert one RJ45 side of the cable into Meter port inside of inverter and the other side into BMS-485port of the meter.

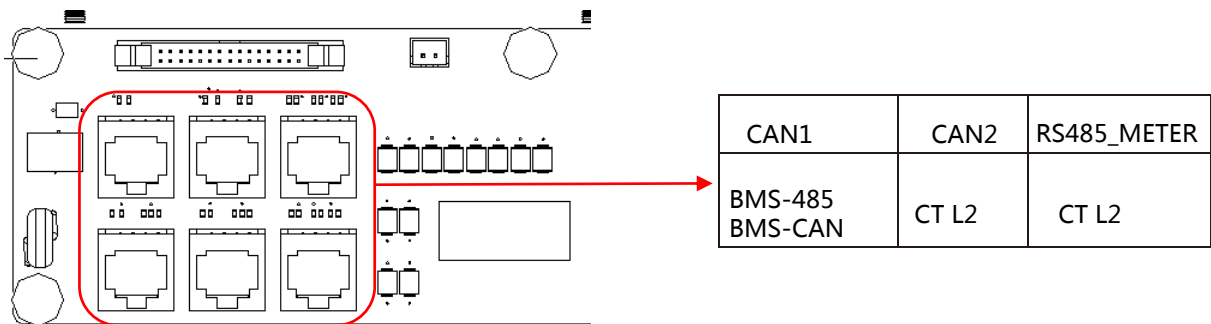

6.7 WiFi Connection (optional)

Inverter provides a WiFi port which can collect data from inverter and transmit it to monitoring-website by WiFi.(Purchase the product from supplier if needed)

1) Diagram

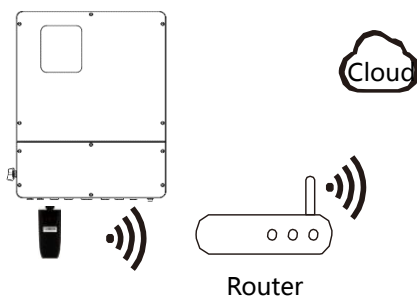

2)WiFi Connection :

Step1. Plug Wifi into "WiFi" port at the bottom of the inverter.

Step2. Build the connection between the inverter and router.

Step3. Create a user account online.(Please check the WiFi user manual for more details).

6.8 GPRS Connection (optional)

Hybrid inverter provides a GPRS(radio frequency) interface which control the switch time of a designated load via an external Smart Plug (purchase the product from supplier if needed.) so that the load mostly consumes PV energy and incurs the lowest-possible energy costs during operation.

1)Diagram

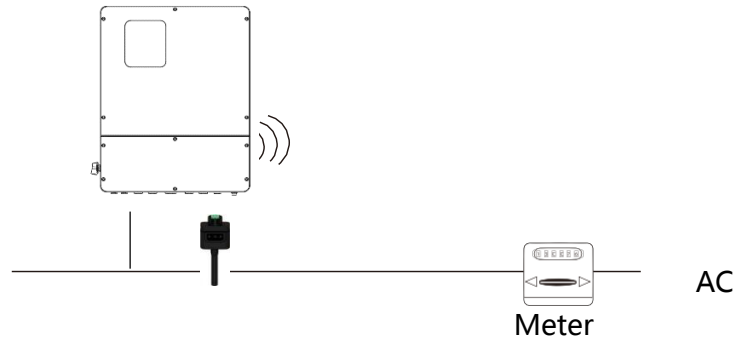

2)GPRS Connection :

Please refer to the Smart Plug user manual for detailed connection

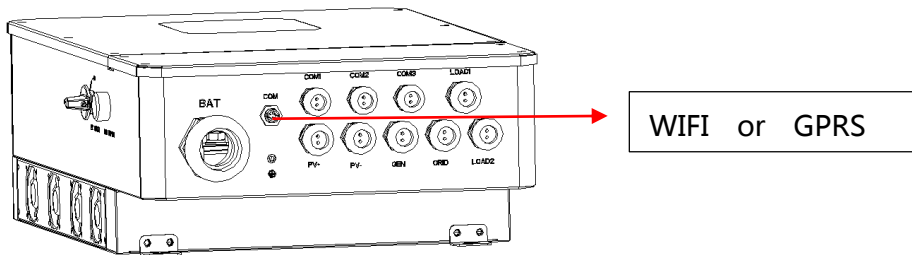

7. LCD Operation

7.1 Control Panel

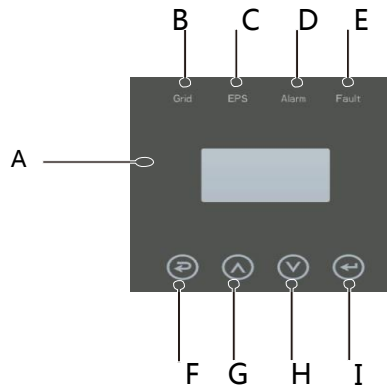

Object	Name	Description
A	LCD	Display the information of the inverter.
B	Indicator LED	lit in green: The inverter is in grid mode. Off: The inverter is in not in grid mode.
C		lit in green: The inverter is in off-grid mode. Off: The inverter is in not in off-grid mode.
D		lit in Yellow: The inverter is in Warning . Off: The inverter has no Inverter Warning
E		lit in red: The inverter is in fault status. Off: The inverter has no errors.
F	Function Button	Esc: Return from current interface or function.
G		Up: Move cursor to upside or increase value.
H		Down: Move cursor to downside or decrease value.
I		Enter: Confirm the selection.

7.2 Instructions for LED Indicator

	Grid (Green)	EPS (Green)	Alarm (Yellow)	Fault (Red)
Initialization	off	off	off	off
Stand-by	off	off	off	off
Grid mode	on	off	off	off
Off-Grid	off	on	off	off
Bypass of mains	off	on	on	off
Fault	off	off	off	on

7.3 Instructions for the use of three modes

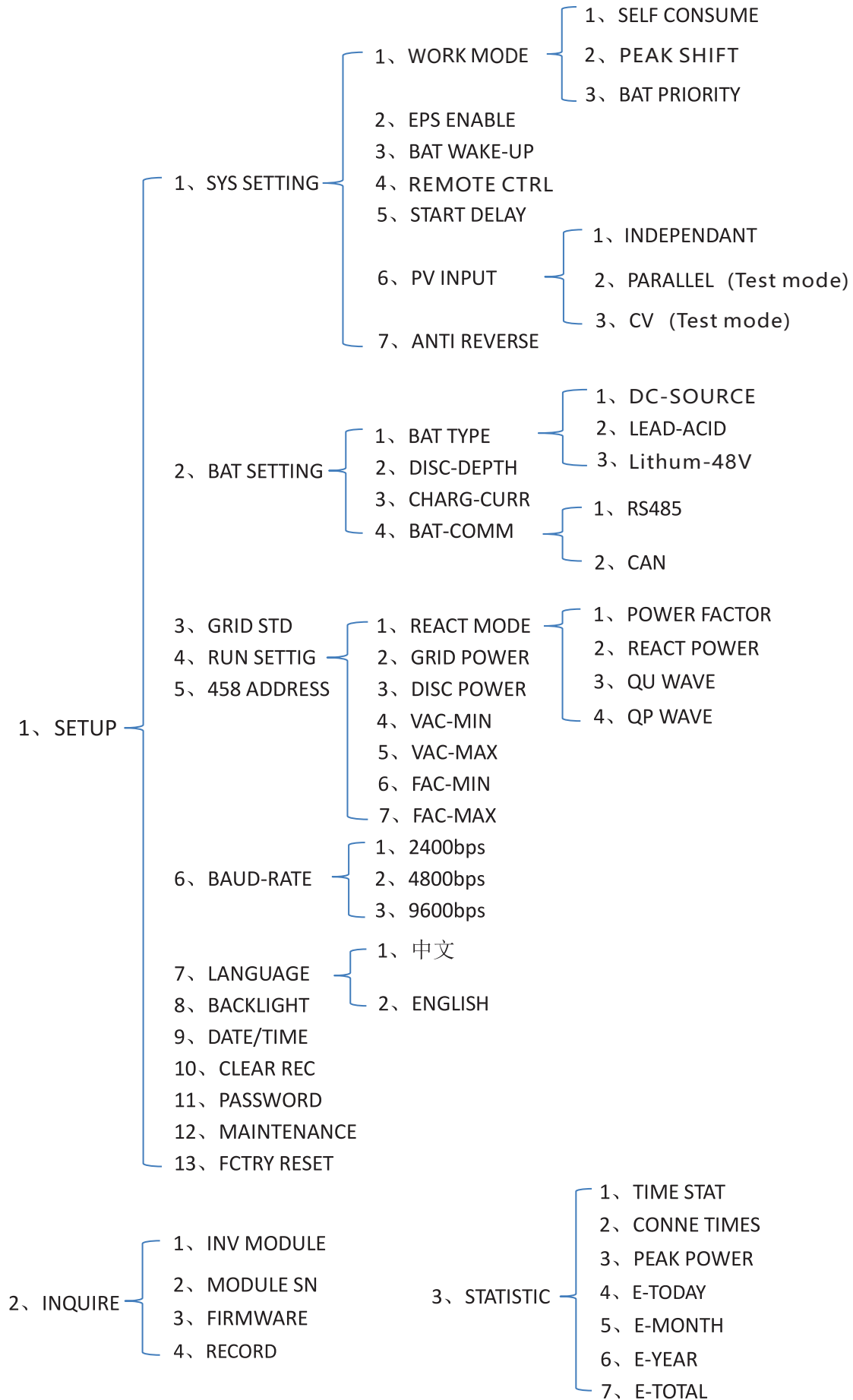

For example, Before selecting the mode, you can set it up according to the local power grid, PV input mode and battery type.

Power grid :

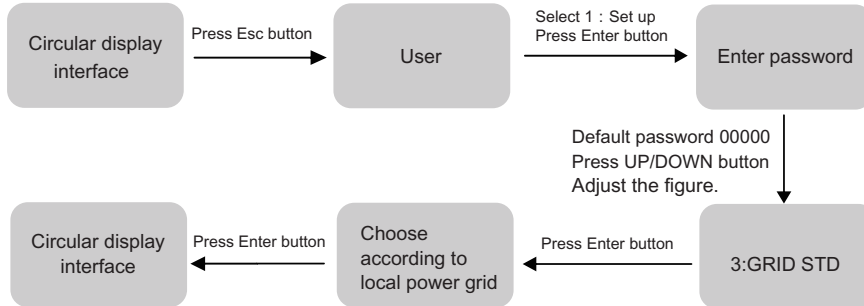

PVinput mode :

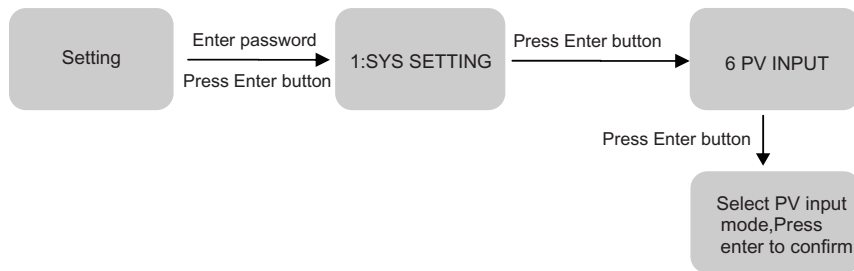

Battery parameters :

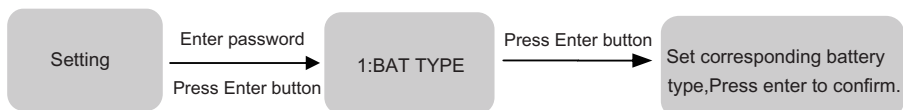

8. Fault diagnosis and solutions

The inverter is easy to maintain. When you encounter the following problems, please refer to the Solutions below, and contact the local distributor if the problem remains unsolved. The following table lists some of the basic problems that may occur during the actual operation as well as their corresponding basic solutions.

Fault diagnosis table

Content	Codes	Solutions
DischgOverCur	00 29	(1) nothing need to do, Wait one minute for the inverter to restart. (2) Check whether the load is in compliance with the specification. (3) Cut off all the power and shut down all the machines; disconnect the load and plug in to restart machines, then check whether the
Over Load	01	(1) Check whether the load is in compliance with the maximum power of the machine. (2) Cut off all the power and shut down all the machines; disconnect the load and plug in to restart machines, then check whether the load is short circuited if the fault has been eliminated. (3) Contact customer service if error warning continues.
BatDisconnect	02	(1) Check if the battery not connected. (2) Check if battery wiring port is open circuited . (3) Contact customer service if error warning continues.
Bat Under Vol	03 04 26	(1) Check if the battery is in line with the presetting, If so, power off and restart. (2) Check if the grid is powered down. If the power is off, wait for the grid to powered up, the grid will automatically charge the battery. (3) Contact customer service if error warning continues.
Bat Over Vol	05 27	(1) Check if the battery is in line with the presetting, If so, power off and restart. (2) Contact customer service if error warning continues.

gird low vol	06	(1)Check if the grid is abnormal. (2) Restart the inverter and wait until it functions normally. (3) Contact customer service if error warning continues.
grid over vol	07	(1)Check if the grid is abnormal. (2) Restart the inverter and wait until it functions normally. (3) Contact customer service if error warning continues.
grid low freq	08	(1)Check if the grid is abnormal. (2) Restart the inverter and wait until it functions normally. (3) Contact customer service if error warning continues.
grid overFreq	09	(1)Check if the grid is abnormal. (2) Restart the inverter and wait until it functions normally. (3) Contact customer service if error warning continues.
gfci over	10	(1) Check PV string for direct or indirect grounding phenomenon. (2) Check peripherals of machine for current leakage. (3) Contact the local inverter customer service if fault remains
SolarUnconnect	11	(1) PV is not connected. (2) PV switch is not closed. (3) Check PV availability.
Grid CtReverse	12	(1) Check whether the CT is connected in the correct direction. (2) Contact customer service if error warning continues.
bus under vol	13	(1) Check the input mode setting is correct. (2) Restart the inverter and wait until it functions normally. (3) Contact customer service if error warning continues.
bus over vol	14	(1) Check the input mode setting is correct. (2) Restart the inverter and wait until it functions normally. (3) Contact customer service if error warning continues.
inv over cur	15	(1) Restart the inverter and wait until it functions normally. (2) Contact customer service if error warning continues.
chg over cur	16	(1) Check if battery wiring is short circuited. (2) Check if charging current is in compliance with presetting. (3) Contact customer service if error warning continues.

bus vol osc	17	(1) Cut off all the power and shut down all the machines and restart. (2) Contact customer service if error warning continues.
inv under vol	18	
inv over vol	19	
InvFreqAbnor	20	
env temp high	21	(1) Cut off all the power of the machine and wait one hour, then turn on the power of the machine. (2) Contact customer service if error warning continues.
bat over temp	23	(1) Disconnect the battery and reconnect it after an hour. (2) Contact customer service if error warning continues.
Bat UnderTemp	24	(1) Check the ambient temperature near the battery to see if it meets the specifications. (2) Contact customer service if error warning continues.
BatCellUnball	25	(1) Break the grid, use the battery to supply power to the load, reconnect the grid side switch after half an hour, Wait another half an hour and check the fault status again.
chg over cur	28	(1) Check if battery wiring port is short circuited . (2) Check if charging current is in compliance with presetting. (3) Contact customer service if error warning continues.
bus soft fail	32	(1) Restart the inverter and wait until it functions normally. (2) Contact customer service if error warning continues.
inv soft fail	33	
bus short inv short	34	
fan fault	35	
Bus Relay Fault	36	
Grid Relay Fault	38	
BACK-UP rly fault	39	
gfcı fault	40	
Load Ct fault	41	
OffgridRlyFal system fault	42	
	44	
	45	
pviso low	37	(1) Check if the PE line is connected to the inverter and is connected to the ground. (2) Contact customer service if error warning continues.

pv short	43	(1) Restart the inverter and wait until it functions normally. (2) Disconnect the PV input, restart the inverter and wait until it functions normally.
bat reverse	46	(1) Check if the inverter battery positive and negative connection is correct. (2) Contact customer service if error warning continues.