

## Drainage Criteria Manual

*Liberty County Water Control Improvement District  
(WCID) #1*



Prepared by



1160 Dairy Ashford, Suite 500  
Houston, Texas 77079

RPS Klotz Associates Project No. 1143.004.000  
August 2016

FOR REVIEW ONLY

Do not use for permitting,  
bidding, or construction.

Engineer: Gary Struzick, PE

Engineer Reg. No.: 64413

Date: August 2016

## Acknowledgements



photo by Theresa Mitschke



photo by Theresa Mitschke



Photo by Theresa Mitschke

**Acknowledgements:** The development of this drainage criteria manual for Liberty County Water Control Improvement District # 1 (WCID or District) was created from various sources of readily available criteria manuals used in the local area or applicable to issues or problems in the WCID # 1 area. The sources included the Jefferson County Criteria Manual, the Brazoria County Drainage Criteria Manual, the Chambers County Drainage Criteria Manual, the Harris County Flood Control Criteria manuals and the Fort Bend Drainage Criteria Manual.

## Table of Contents

Acknowledgements.....	ii
Table of Contents.....	iv
List of Tables .....	ix
List of Exhibits .....	x
<b>1 PURPOSE AND POLICIES .....</b>	<b>1</b>
1.1 Purpose of the Drainage Criteria Manual .....	1
1.2 Drainage Policies.....	1
1.2.1 Zero Impact (No Adverse Impacts) .....	1
1.2.2 Level of Protection .....	2
1.2.3 Storm Water Detention .....	2
1.2.4 Flood Plain Storage .....	2
1.2.5 Primary and Secondary Drainage Facilities.....	3
<b>2 REVIEW AND APPROVAL OF DRAINAGE PLANS.....</b>	<b>4</b>
2.1 Types of Submittals.....	4
2.2 Activities for which Submittals to the District are required .....	4
2.3 General Requirements for Various Submittals .....	5
2.3.1 New Development .....	5
2.3.2 Hydrologic Studies .....	6
2.3.3 Hydraulic Studies of Primary Drainage Facilities .....	6
2.3.4 Detention Studies.....	7
2.3.5 General Engineering Report Requirements .....	8
2.4 Review and Approval of Submittals to WCID #1.....	10
<b>3 HYDROLOGIC &amp; HYDRAULIC CONCEPTS.....</b>	<b>11</b>
3.1 Definitions of Basic Technical Terms .....	11
3.2 Basic Hydrologic Concepts .....	12

3.2.1	The Hydrologic Cycle .....	12
3.2.2	Design Rainfall Events .....	12
3.2.3	Infiltration and Runoff.....	13
3.2.4	Runoff Hydrographs .....	13
3.3	Basic Hydraulic Concepts .....	13
3.3.1	Manning’s Equation .....	13
3.3.2	Conveyance .....	14
3.4	Effects of Urbanization.....	14
3.5	Flood Insurance Concepts.....	15
4	HYDROLOGY.....	17
4.1	Drainage Areas up to 200 Acres.....	17
4.1.1	Introduction .....	17
4.1.2	The Rational Method .....	17
4.1.3	Establishing the Drainage Area .....	17
4.1.4	Determining Runoff Coefficients .....	17
4.1.5	Establishing the Time of Concentration.....	19
4.1.6	Computation of Rainfall Intensity .....	20
4.1.7	Analyzing a Watershed with Multiple Sub-Areas or Computation Points.....	21
4.2	Drainage Areas Greater than 200 Acres .....	21
4.2.1	Watershed Boundaries .....	21
4.2.2	Rainfall Data .....	22
4.2.3	Infiltration Losses .....	23
4.2.4	Initial Abstraction.....	24
4.2.5	Percent Impervious Cover.....	26
4.2.6	Loss Rate Computations in HEC-HMS .....	27
4.2.7	Unit Hydrograph Methodology.....	27
4.2.8	Streamflow Routing .....	27

4.2.9	Combining Hydrographs .....	28
<b>1</b>	<b>HYDRAULICS OF PRIMARY DRAINAGE FACILITIES .....</b>	<b>30</b>
5.1	General Design Requirements for Primary Drainage Facilities.....	30
5.1.1	Design Storm Frequencies .....	30
5.1.2	Design Requirements for Earthen Channels.....	30
5.1.3	Minimum Design Requirements for Trapezoidal Concrete-Lined Channels.....	31
5.1.4	Design Requirements for Rectangular Concrete Low-Flow Sections.....	32
5.1.5	Structural Requirements for Culverts .....	33
5.1.6	Design Requirements for Bridges .....	34
5.1.7	Enclosed Drainage Systems.....	35
5.1.8	Maximum Flow Velocities .....	35
5.1.9	Maintenance .....	36
5.2	Hydraulic Analysis of Primary Drainage Facilities .....	36
5.2.1	Acceptable Open Channel Design Methodologies.....	36
5.2.2	Acceptable Bridge and Culvert Design Methodologies.....	37
5.2.3	Acceptable Enclosed Drainage System Design Methodologies .....	37
5.2.4	Flow Data .....	37
5.2.5	Boundary Conditions.....	38
5.2.6	Cross-Section Data .....	39
5.2.7	Manning’s Roughness Coefficient.....	40
5.2.8	Bridge and Culvert Data .....	44
5.2.9	Floodway Analysis.....	47
<b>6</b>	<b>DETENTION ANALYSIS.....</b>	<b>48</b>
6.1	General Design Requirements .....	48
6.1.1	Design Storm Frequencies .....	48
6.1.2	Detention Basin Location and Geometry.....	49
6.1.3	Maintenance Berms.....	50

6.1.4	Maintenance .....	50
6.1.5	Pumped Detention Facilities .....	50
6.1.6	Multi-Purpose Design.....	50
6.1.7	Extreme Event Overflow Structures.....	51
6.2	Peak Discharge Rates .....	51
6.2.1	Methodology.....	51
6.2.2	Allowable Peak Discharge Rates .....	51
6.2.3	Off-Site Flows .....	51
6.3	Detention Analysis for Drainage Areas up to 200 Acres .....	52
6.3.1	Detention Analysis for Drainage Areas Up to 200 Acres .....	52
6.3.2	Design of Outfall Structures for Drainage Areas up to 200 Acres.....	53
6.4	Detention Analysis for Drainage Areas Greater than 200 Acres.....	55
6.4.1	Acceptable Detention Routing Software Programs .....	55
6.4.2	Inflow Hydrographs.....	55
6.4.3	Stage-Storage Relationship.....	55
6.4.4	Outfall Structure .....	55
6.4.5	Acceptable Results .....	56
6.5	Downstream Impacts .....	56
7	EROSION AND SEDIMENT CONTROL .....	58
7.1	Effects of Erosion and Sedimentation.....	58
7.2	Areas with High Erosion Potential .....	58
7.3	Slope Protection Methods .....	59
7.3.1	Turf Establishment .....	59
7.3.2	Slope Paving .....	59
7.3.3	Rip-Rap .....	60
7.3.4	Acceptable Velocities for Various Slope Treatments.....	60
7.4	Requirements for Channel Bends and Confluences .....	61

7.5	Channel Backslope Drain Systems .....	62
7.6	Interceptor Structures .....	62
7.7	Stormwater Pollution Prevention Plans.....	63
7.8	Special Energy Dissipation Structures.....	63
8	LEVEED AREAS .....	64
8.1	Internal Drainage System.....	64
8.2	Levee System .....	64
8.2.1	Frequency Criteria.....	64
8.2.2	Design.....	64
8.3	Pump Stations .....	67
8.3.1	Frequency Criteria.....	67
8.3.1.1	Design Criteria Assuming Coincidental Events.....	67
8.3.1.2	Design Criteria Assuming Same Event .....	68
8.3.2	Design Criteria.....	68
8.4	Gravity Outlet and Outfall Channel.....	69
8.5	Review Process.....	69
9	DRAINAGE DESIGN CRITERIA FOR RURAL SUBDIVISIONS .....	71
9.1	Purpose .....	71
9.2	Qualifications .....	71
9.3	Design Criteria.....	71
9.4	Submittals .....	72
9.5	Technical Analysis of Detention Requirements for Rural Subdivisions .....	73
9.6	Analysis of Runoff Volume .....	73
9.7	Analysis of Runoff Rate .....	74
9.8	Determination of Required Detention.....	75



## List of Tables

TABLE 4-1: RATIONAL METHOD COEFFICIENTS FOR 2- TO 10-YEAR STORMS.....	18
TABLE 4-2: RATIONAL METHOD RUNOFF COEFFICIENT ADJUSTMENT FACTORS.....	19
TABLE 4-3: RAINFALL INTENSITY PARAMETERS .....	20
TABLE 4-4: RAINFALL DATA FOR LIBERTY COUNTY WCID #1, TEXAS .....	22
TABLE 4-5: GREEN & AMPT LOSS PARAMETERS .....	23
TABLE 4-6: SCS CURVE NUMBERS .....	25
TABLE 4-7: PERCENT IMPERVIOUS COVER VALUES FOR WCID #1, TEXAS.....	26
TABLE 5-1: MINIMUM THICKNESS AND REINFORCEMENT FOR CONCRETE SLOPE PAVING .....	32
TABLE 5-2: MAXIMUM ALLOWABLE VELOCITIES IN OPEN CHANNELS .....	36
TABLE 5-3: FREQUENCIES OF COINCIDENTAL OCCURRENCE FOR DETERMINING TAILWATER ELEVATIONS IN RECEIVING CHANNELS .....	39
TABLE 5-4: MANNING’S ROUGHNESS COEFFICIENTS .....	42
TABLE 5-5: PARAMETERS USED IN COMPUTING CHANNEL ROUGHNESS COEFFICIENTS.....	43
TABLE 5-6: PARAMETERS USED IN COMPUTING FLOOD PLAIN ROUGHNESS COEFFICIENTS.....	44
TABLE 5-7: MANNING’S ROUGHNESS COEFFICIENTS FOR CULVERTS .....	45
TABLE 5-8: ENTRANCE LOSS COEFFICIENTS FOR CULVERTS .....	46
TABLE 5-9: FHWA CHART AND SCALE NUMBERS FOR CULVERTS.....	46
TABLE 6-1: 100-YEAR RAINFALL EXCESS VALUES FOR WCID # 1, TEXAS.....	53
TABLE 7-1: MINIMUM THICKNESS AND REINFORCEMENT FOR CONCRETE SLOPE PAVING .....	59
TABLE 7-2: MAXIMUM ALLOWABLE VELOCITIES IN OPEN CHANNELS.....	61
TABLE 7-3: MINIMUM EROSION PROTECTION FOR CHANNEL CONFLUENCES.....	61
TABLE 7-4: MINIMUM EXTENT OF EROSION PROTECTION AT CONFLUENCES.....	62
TABLE 9-1: 100-YR 24-H RAINFALL EXCESS FOR VARYING IMPERVIOUS COVER .....	73
TABLE 9-2: COMPARISON OF DETENTION STORAGE REQUIREMENTS.....	76

## List of Exhibits

- EXHIBIT 1-1: LIBERTY COUNTY DRAINAGE FACILITIES
- EXHIBIT 3-1: SKETCH OF THE HYDROLOGIC CYCLE
- EXHIBIT 3-2: RELATIONSHIP BETWEEN UNIT AND RUNOFF HYDROGRAPHS
- EXHIBIT 3-3: CONCEPTS ASSOCIATED WITH MANNING'S EQUATION
- EXHIBIT 3-4: RELATIONSHIP BETWEEN THE 100-YEAR FLOODPLAIN AND FLOODWAY
- EXHIBIT 3-5: TYPICAL CHAMBERS COUNTY FLOOD INSURANCE RATE MAP
- EXHIBIT 4-1: SCS UPLANDS METHOD
- EXHIBIT 4-2: WATERSHED WITH MULTIPLE SUB-AREAS
- EXHIBIT 4-3: USGS SIR 2004-5041 IDF CURVES FOR CHAMBERS COUNTY
- EXHIBIT 5-1: TYPICAL EARTHEN CHANNEL DESIGN
- EXHIBIT 5-2: TYPICAL SECTION GRASS-LINED TRAPEZOIDAL CHANNEL
- EXHIBIT 5-3: TYPICAL SECTION CONCRETE-LINED TRAPEZOIDAL CHANNEL
- EXHIBIT 5-4: TYPICAL CROSS-SECTION, CONCRETE-LINES WITH RECTANGULAR LOW-FLOW SECTION
- EXHIBIT 6-1: TYPICAL DETENTION BASIN LAYOUT
- EXHIBIT 6-2: TYPICAL DETENTION BASIN CROSS-SECTION
- EXHIBIT 6-3: DETENTION STORAGE VOLUME FOR DRAINAGE AREAS UP TO 200 ACRES
- EXHIBIT 7-1: SLOPE PROTECTION REQUIREMENTS AT STREAM CONFLUENCES
- EXHIBIT 7-2: SLOPE PROTECTION REQUIREMENTS AT CHANNEL BENDS
- EXHIBIT 7-3: TYPICAL ROADSIDE DITCH INTERCEPTOR STRUCTURE
- EXHIBIT 7-4: TYPICAL BACKSLOPE INTERCEPTOR STRUCTURE
- EXHIBIT 7-5: TYPICAL ROCK CHECK DAM
- EXHIBIT 6-1: FLOW/FREQUENCY
- EXHIBIT 6-2: COMPARISON OF DETENTION STORAGE REQUIREMENTS
- EXHIBIT 9-1: DETENTION STORAGE REQUIREMENTS FOPR RURAL SUBDIVISION
- EXHIBIT 9-2: COMPARISON OF DETENTION STORAGE REQUIREMENTS

# 1 PURPOSE AND POLICIES

## 1.1 Purpose of the Drainage Criteria Manual

The primary purpose of this drainage criteria manual is to establish standard principles and practices for the analysis, design, and construction of primary drainage systems in Liberty County WCID #1.

Storm water management is an essential component of community infrastructure and serves to provide both increased convenience and protection of life and property. A properly designed system will detain and/or carry away runoff from more frequent rainfall events while allowing the movement of vehicles to homes and businesses. Such a system will also detain and/or drain storm water from an infrequent “extreme rainfall event” so that habitable structures are not damaged and major streets are passable to public safety vehicles.

Providing Liberty County WCID #1 with an effective storm water management system that allows sustainable community growth is a continuing challenge. It involves setting minimum standards, planning for future detention basins and drainage channels, working with private development interests, coordinating with governmental agencies, and maintaining the efficiency of the existing system. The existing Liberty County Drainage Facilities can be seen in the Exhibit 1-1

Recognizing that storm water system development should be guided by adopted policies and criteria, WCID #1 launched a planning process aimed at setting consistent standards responsive to the needs of property developers and design engineers and compliant with federal and state regulations. This Drainage Criteria Manual applies to all areas within the WCID #1 jurisdictions. However, if the project falls within the jurisdiction of another entity or covers areas in both entities joint coordination and criteria may apply. Coordinate with WCID #1 if this situation applies to your project.

## 1.2 Drainage Policies

### 1.2.1 Zero Impact (No Adverse Impacts)

An impact is defined as a change in the response of a watershed to a storm event. The most common impacts are changes in the volume of runoff, changes in the rate of runoff, and changes in flooding depths. Impacts may be adverse or beneficial. Adverse impacts are those which increase the potential for flooding damages. Beneficial impacts, on the other hand, reduce the potential for flood damage. The term zero impact is normally defined as the absence of adverse impact. WCID #1 maintains a strict zero impact policy in all watersheds located wholly or partially within the incorporated boundaries of the District. This means that neither increases in upstream

flood levels nor in downstream flow rates are allowed in areas where there is the potential for flooding damages from storms with recurrence intervals of 100 years or less.

Adverse impacts associated with new development must be identified and mitigated. Acceptable mitigation measures may include storm water detention, creation of new flood plain storage, channel improvements, and improvements to channel structures. A “zero impact” policy will be enforced by the WCID #1. No adverse impacts on downstream peak flow rates or upstream flood levels will be allowed. No net loss in existing flood plain storage will be allowed.

### 1.2.2 Level of Protection

The level of protection is generally regarded as the storm recurrence interval which future primary drainage facilities, such as open channels, roadway culverts, and detention facilities, are designed to accommodate without significant flooding damages. For example, providing a 100- year level of protection would indicate that the future primary drainage facilities are designed to carry storm runoff from a 100-year storm event without significant flooding of homes and other buildings. For the analysis and design of future primary drainage facilities, WCID #1 has adopted a 100-year level of protection.

### 1.2.3 Storm Water Detention

Storm water detention refers to the temporary storage of storm runoff in ponds or other storage facilities. The provision of this temporary storage allows storm runoff to be discharged to a receiving stream at a lower rate, thereby protecting downstream areas from increased flooding damages associated with increased flow rates and higher flood levels. WCID #1 recognizes the value of storm water detention in reducing the potential for flood damages and allows the use of detention facilities in addition to adding conveyance capacity for mitigating impacts associated with new development and drainage improvements.

### 1.2.4 Flood Plain Storage

Flood plain storage is defined for the purposes of this manual as the space below 100-year flood levels. This space is available for the temporary storage of flood waters during extreme storm events. Preservation of this air space is extremely important because flood plain storage serves to reduce downstream peak flow rates. WCID #1 prohibits reductions in existing flood plain storage along all streams which pass through the boundaries of the District.

### 1.2.5 Primary and Secondary Drainage Facilities

For the purposes of this manual, primary drainage facilities include open channels, bridges, culverts, and enclosed drainage systems (i.e., open channel that has been enclosed). Secondary drainage facilities include storm sewer systems, roadside ditches and associated structures, and other facilities such as sheet flow swales, small culverts, and other structures which typically serve relatively small drainage areas, as well as lot grading and drainage requirements.



## 2 REVIEW AND APPROVAL OF DRAINAGE PLANS

### 2.1 Types of Submittals

The types of engineering submittals typically made in connection with new development or drainage studies include the following:

- **Engineering Reports:** These documents, which may take the form of letter reports or more extensive and formal bound reports, normally describe the results of analyses of existing and/or proposed drainage conditions. Engineering reports may be submitted as a basis for better understanding of existing conditions (i.e., a flood plain revision report), to support a request for approval of construction documents for a proposed facility (i.e., a preliminary engineering report for a roadway improvement project), or to serve as a plan for future conditions (i.e., a master drainage report for a given watershed).
- **Construction Documents:** These include engineering drawings and specifications for a proposed facility or development which will affect storm water drainage or flood control.
- **Permit Applications:** These are applications for building permits, flood plain fill permits, and other permits required by the WCID #1.

### 2.2 Activities for which Submittals to the District are required

WCID #1 requires that engineering submittals be prepared for all activities which may affect the rate, direction, or volume of storm water runoff, or the depth and velocity of flow in primary drainage facilities, and other infrastructure within the District's jurisdiction as applicable. The District will review the following three types of projects:

1. Construction of new projects, modification and/or improvement of existing facilities, or impacting the existing facilities which are maintained by the District, which include:
  - a. Open channels
  - b. Bridges, culverts, and other hydraulic structures associated with open channels
  - c. Detention basins
2. Construction of drainage facilities which are physically located in, on, over, under, or adjacent to a drainage facility maintained by the District:
  - a. Land development projects

- b. Roads and highways
  - c. Bridges and culverts
3. Development or public projects that do not affect the facilities maintained by the District such as natural channels, lakes, drainage-ways, etc. or future drainage facilities described in a drainage master plan:
- a. Proposed subdivision development
  - b. Residential and commercial site development
  - c. Roads and highways

## 2.3 General Requirements for Various Submittals

The various submittals presented to WCID # 1 for review should be as complete and as well-documented as possible. However, if the project falls within the jurisdiction of another entity or jointly with two entities including WCID # 1, the submittals related to the project must be sent to them. The other entity can then forward a copy of the approval letter to WCID # 1. The general requirements described in this section should be satisfied for all submittals. The intent of these requirements is to insure that the following aspects of the proposed activity are made clear to the reviewer:

### 2.3.1 New Development

Submittals for all new development shall include the following items:

- a plat of the development illustrating property boundaries, individual lot boundaries, streets, drainage easements, etc.
- a hydrologic impact analysis which identifies the potential effects of the development on downstream peak flow rates.
- if necessary, a hydraulic impact analysis which identifies the potential effects of the development on upstream flood levels.
- a preliminary engineering report which presents the results of impact analyses, describes proposed mitigation measures, provides construction cost estimates, etc.

Preliminary construction plans for proposed streets, storm drainage facilities, utilities, and other features may be submitted along with the preliminary engineering report. Final construction



plans should be prepared after WCID #1 has completed its review of the report and issued written comments.

### 2.3.2 Hydrologic Studies

Major watershed hydrologic studies will be summarized in a report which contains sufficient text, exhibits, and computer output to completely describe the methods, data, and assumptions used in the analysis, as well as the results obtained. Information provided in the report should include the following:

- A description of the analysis and the results obtained
- Tabulations of all hydrologic modeling parameters
- Tabulations of all computed peak flow rates
- A watershed map which illustrates the borders of each sub-area included in watershed modeling
- A hydrologic parameter map which illustrates all watercourse lengths, drainage areas, and developed areas
- Output from all hydrologic models used in the analysis
- A computer compact disk or flash drive containing input files for all hydrologic and hydraulic models

### 2.3.3 Hydraulic Studies of Primary Drainage Facilities

For hydraulic analyses and designs of primary drainage system components, an engineering report containing the following items should be submitted:

- Sufficient text to summarize the methods, data, and assumptions used in completing the analysis, as well as the results obtained
- Calculations and other information supporting the flow rates used in the analysis
- Tabulations of hydraulic modeling data and results
- Vicinity and site maps which illustrate the location of the project area and the extent of the stream reach being analyzed
- A plotted stream profile(s)
- Plotted cross-sections of the stream with computed flood levels superimposed

- A copy of the effective Flood Insurance Rate Map (FIRM) for the project area and, as needed, a proposed conditions flood plain and floodway map which illustrates proposed changes in flood plain and floodway boundaries
- Copies of all hydraulic calculations
- An analysis of the effects of proposed improvements on downstream peak flow rates and upstream flood levels
- Recommendations for mitigating any adverse impacts associated with proposed improvements to channels or structures
- Output from all hydraulic computer models used in the analysis
- A computer disk, flash drive or other media containing input files for all hydraulic models

For studies involving improvements to open channels and hydraulic structures or designs of new open channels, a right-of-way (ROW) map should also be submitted. Preliminary construction plans may be submitted along with the engineering report. Final plans should be prepared after WCID #1 has completed its review of the engineering report and issued comments.

### 2.3.4 Detention Studies

The following information must be submitted in support of designs for detention facilities:

- Vicinity, site, and watershed maps which clearly illustrate the location of the facility, its physical extents and configuration, its drainage area, and the relationship of its drainage area to the overall boundaries of the major watershed in which it is located
- A ROW map which illustrates all existing and proposed ROWs in the immediate vicinity of the detention facility
- Discharge calculations which identify peak flow rates for pre-development and post-development conditions for the design storm event
- Hydraulic calculations on which the design of the detention discharge structure is based
- For facilities with a drainage area of less than 200 acres, calculations establishing the required detention storage volume
- For facilities having a drainage area of 200 acres or more, a detention flood routing analysis which assesses the effectiveness of the detention basin in mitigating impacts on downstream peak flow rates

- Calculations involving the required capacity of supplemental and/or emergency discharge structures
- exhibits which illustrate the configuration of the detention facility, inflow structure, and discharge structure
- Benchmark information
- A soils report which discusses the suitability of the soil for construction of the proposed facilities

These items should be submitted in supported of a written report which describes the proposed location and configuration of the detention facility, the methods used in the design of the facility, and the conclusions of the detention analysis with regard to the effectiveness of the facility in mitigating increases in downstream peak flow rates. Preliminary construction plans may be submitted along with the engineering report. Final plans should be prepared after WCID #1 has completed its review of the engineering report and issued comments

### 2.3.5 General Engineering Report Requirements

It is recommended that engineering reports be prepared in such a manner as to include all of the necessary information without referencing previous submittals. Each report should utilize text, tables, and exhibits to thoroughly document the methods, data, and assumptions used in completing analyses of the proposed activity as well as the results obtained. Detailed computations and computer printouts should be attached to the report in the form of appendices. All reports should be bound to insure that the report text, exhibits, and attachments stay together. All reports and accompanying materials should be submitted in a manageable format. Maps should be 24" x 36" or smaller. All maps and other exhibits must be legible and information should be presented a clear and concise manner.

The following exhibits and calculations should be submitted with engineering reports as appropriate:

- **Vicinity Map:** A map showing the project site with respect to recognizable landmarks in the vicinity. This could be a city map with the boundaries of a new development or the limits of a channel improvement project indicated to mark the project location.
- **Site Map:** This is a detailed map of the project site which illustrates the type and extent of activities which are proposed to be completed. For new developments, a plat with all proposed streets, lot boundaries, etc. may be used to satisfy this requirement.

- **Watershed or Drainage Map:** A watershed or drainage map which illustrates all drainage boundaries, flow directions, and computation points.
- **Discharge Calculations:** Calculations specifying computed discharges at key locations, with comparisons of existing and proposed discharges where appropriate. Drainage areas, runoff coefficients, rainfall depths and intensities, infiltration loss parameters, unit hydrograph parameters, and other applicable hydrologic data should be included and clearly documented. For computer applications, printouts should be attached.
- **Hydraulic Calculations:** Hydraulic calculations specifying the methods used in analyzing channels, storm sewers, and other hydraulic structures and providing a summary of the results obtained. Cross-section data, roughness coefficients, flow rates, and other data should be clearly documented. For computer applications, printouts should be attached.
- **Benchmark Information:** A description of the benchmark used to establish existing and proposed elevations in the project area, including the exact location, the elevation, and the source of the elevation.
- **Right-of-Way Map:** A map which illustrates existing and proposed channel and utility ROWs and easements. Include both underground and overhead utilities and all drainage easements. Sufficient ROW must be permanently set aside to allow for the construction of the most extensive permanent drainage facilities proposed to pass through the development in the future. These facilities may include open or enclosed channels, storm sewers, ditches, or swales. For channels, the width of the ROW must be adequate to provide for the channel itself plus minimum maintenance berm widths. For enclosed systems, the minimum ROW width is equal to the widest dimension of the underground conduit plus two times the maximum depth from finished ground to the invert of the conduit, or 30 feet, whichever is greatest
- **Soils Report:** A soils report, prepared by a qualified geotechnical engineer, which identifies the existing soil types and assesses the suitability of the soil for the proposed activity. The soils report should address erosion and slope stability in areas subject to the action of storm runoff.
- **Plotted Stream Profile:** A profile of the subject stream which includes computed water surface profiles, existing and proposed flow-line profiles, the locations of existing and proposed bridges, culverts, and utility crossings, the locations of tributary confluences and major storm sewer outfalls in or near the project area, and the locations of hydraulic structures such as dams, weirs, and drop structures.

- **Plotted Cross-Sections:** Typical cross-sections of the subject stream for both existing and proposed conditions.
- **Flood Plain Maps:** A FIRM showing the boundaries of the existing 100-year flood plain and floodway in the project area and a separate map which illustrates proposed changes in flood plain or floodway boundaries.
- **Facility Layout Map:** Plan, elevation, and cross-section views of drainage facilities such as detention basins, roadway culverts, bridges.
- **Erosion Control:** All drainage facilities must be designed and maintained in a manner which minimizes the potential for damage due to erosion. No bare earthen slopes will be allowed. Various slope treatments, including turf establishment, concrete slope paving, and rip-rap, are accepted. Flow velocities should be kept below permissible values for each type of slope treatment. Interceptor structures and backslope swale systems are required to prevent sheet flows from eroding the side slopes of open channels and detention facilities.

## 2.4 Review and Approval of Submittals to WCID #1

Upon receiving an engineering submittal, representatives of WCID #1 will check it for completeness and will request additional information as needed. Upon receiving all of the information necessary to thoroughly evaluate the submittal, the District will complete the review. Written comments will be forwarded to the submitter, who will make any corrections or adjustments to the analysis and re-submit a final package. Upon determining that all necessary corrections and adjustments have been made, the District will prepare a written acceptance of the submittal.

## 3 HYDROLOGIC & HYDRAULIC CONCEPTS

The purpose of this chapter is to present a brief summary of hydrologic and hydraulic concepts that are required to understand and apply the criteria presented in this manual. This chapter also includes a description of the effects of urbanization on the watershed as well as a description of the National Flood Insurance Program (NFIP).

### 3.1 Definitions of Basic Technical Terms

- **Conveyance:** the ability of a channel or conduit to carry water in the downstream direction
- **Cross-sectional area:** the total area available to carry flow, measured at a vertical plane (cross-section), which cuts across a channel or conduit perpendicular to the direction of flow.
- **Flood plain:** an area inundated by flood waters during or after a storm event of a specific magnitude.
- **Friction loss:** a loss in energy associated with friction between flowing water and the sides of a channel or conduit
- **Hydraulic radius:** a parameter computed as the cross-sectional area divided by the wetted perimeter
- **Hydrology:** the study of the processes through which atmospheric moisture passes between the time that it falls to the surface of the earth as rainfall and the time that it returns to the atmosphere.
- **Hydrograph:** a graph which relates rate of flow and time
- **Infiltration:** the process by which rainfall soaks into the ground
- **Manning's Equation:** a mathematical formula which relates the velocity or rate of flow in a channel or conduit to the physical characteristics of the channel or conduit
- **Minor loss:** a loss in energy associated with changes in flow direction or velocity
- **Probability:** the chance, usually expressed in percent that a storm event of a particular intensity and duration will occur in any given year; equal to the reciprocal of the recurrence interval
- **Rainfall intensity:** the rate at which rainfall occurs, typically expressed in inches per hour
- **Recurrence interval:** the average period of time that will elapse between storms of a particular intensity and duration (equal to the reciprocal of the probability)

- **Roughness Coefficient:** a number which represents the relative resistance to flow in a channel or conduit
- **Runoff:** precipitation which does not infiltrate into the ground, but instead makes its way to a storm water drainage facility
- **Storm Event:** a single period of heavy rainfall, normally lasting from a few minutes to a few days
- **Time of Concentration:** the time required for water to travel from the most remote point in a watershed to the point at which a peak flow rate or runoff hydrograph is to be computed
- **Unit Hydrograph:** a runoff hydrograph which represents the response of a watershed to 1 inch of runoff
- **Watercourse:** a path which water follows from the boundary of a watershed to the watershed outlet
- **Wetted Perimeter:** the total distance along a channel or conduit cross-section that is in contact with water that is flowing in the channel or conduit

## 3.2 Basic Hydrologic Concepts

### 3.2.1 The Hydrologic Cycle

The term hydrologic cycle refers to a series of processes through which moisture falls to earth as precipitation, and returns to the atmosphere. The basic processes involved in the hydrologic cycle include rainfall, infiltration, interflow, storage, evaporation, and transpiration. Exhibit 3-1 illustrates the interaction of these processes.

### 3.2.2 Design Rainfall Events

Rainfall normally occurs in irregular patterns with respect both to space and time. However, synthetic rainfall events (referred to as “design storm events”) are typically used for hydrologic analyses. These design storm events are developed through statistical analyses of long periods of recorded rainfall data and are defined by the recurrence interval and storm duration. For example, a 100-year, 24-hour storm is a 24-hour duration design storm which has a one-percent probability of occurring in any given year. As discussed in Chapter 4, the 100-year, 24-hour rainfall depth for WCID #1 is 12.2 inches. The 5-yr and 25-yr, 24-hour storms have associated rainfall depths of 6.0 inches and 9.8 inches respectively. Table 4-4 provides a summary of the relationship between rainfall depth, duration, and recurrence interval for WCID #1, Texas.

### 3.2.3 Infiltration and Runoff

A portion of the rainfall that reaches the earth soaks into the ground via infiltration, while the balance of the rainfall is called runoff (Exhibit 3-1). Since infiltration increases with the porosity of the soil, infiltration for clay soils is less than for sandy soils. Infiltration is reduced as the moisture content of the soil is increased and ceases when the soil becomes saturated. As infiltration decreases, runoff increases and vice versa.

### 3.2.4 Runoff Hydrographs

Runoff hydrographs are relationships between the rate of runoff and time. Hydrographs are important because they provide information on the peak rate of runoff and variations in runoff rates throughout the duration of a particular storm event. These variations can be significant in defining the response of a watershed to a rainfall event, especially when the watershed is large and runoff continues over many hours or days.

A unit hydrograph is a hydrograph which reflects the response of a watershed to a rainfall event that produces exactly one-inch of runoff. Runoff hydrographs for storm events producing more or less than one-inch of runoff are computed from a unit hydrograph by multiplying each individual flow rate in the unit hydrograph by the actual runoff volume in inches. This computation is based on various hydrologic parameters and is performed automatically by software programs such as HEC-HMS, which was developed by the Hydrologic Engineering Center of the U.S. Army Corps of Engineers (USACE). Exhibit 3-2 illustrates the relationship between unit hydrographs and runoff hydrographs.

## 3.3 Basic Hydraulic Concepts

### 3.3.1 Manning's Equation

Manning's equation is a commonly used formula that relates the hydraulic capacity and the physical condition of an open channel, a storm sewer pipe, or a box culvert. The equation is written as follows:



$$Q = \left( \frac{1.49}{n} \right) AR^{2/3} S^{1/2} \quad \text{Equation 3-1}$$

- where:  $Q$  = the flow rate (cubic feet per second);  
 $n$  = a roughness coefficient related to the relative condition of the channel or structure;  
 $A$  = the cross-sectional area of flow (square feet);  
 $R$  = the hydraulic radius, which is computed as the flow area divided by the wetted perimeter (feet);  
 $S$  = the slope of the channel or structure;

The roughness coefficient ( $n$  value) is a measure of the roughness of the surfaces with which water comes into contact. For example, higher  $n$  values represent rougher surfaces and lower  $n$  values represent smoother surfaces. Information on selecting  $n$  values for open channels and storm sewers is included in Chapter 5. Exhibit 3-3 illustrates some of the basic concepts associated with Manning's Equation.

### 3.3.2 Conveyance

Conveyance is a measure of the capacity of a channel, flood plain, or hydraulic structure to carry storm water. As indicated in Equation 3-2, conveyance increases with the cross-sectional area of flow, the depth of flow in the structure, and the smoothness of the surfaces with which water comes into contact. For example, enlarging a drainage channel will increase the conveyance and the rate of storm water flow within the channel. Clearing away trees and brush from a channel will have the same effect. Replacing a corrugated metal pipe (CMP) with a reinforced concrete pipe (RCP) of the same diameter also results in an increased conveyance because of the smoother interior of the RCP.

$$K = \frac{1.49}{n} AR^{2/3} \quad \text{Equation 3-2}$$

- where:  $K$  = conveyance (cubic feet per second).

## 3.4 Effects of Urbanization

Urbanization includes activities such as land clearing, new development, roadway construction, improvements to drainage systems, changes in natural land topography, placement of fill in flood plains,

and construction of pavements and other impervious surfaces. These types of activities have significant effects on the response of a watershed to rainfall, which are summarized below.

- **Increased Volume of Runoff:** Urbanization is typically accompanied by an increase in the percentage of the ground surface that is covered by impervious materials, which decreases infiltration and increases the volume of runoff.
- **Increased Rate of Runoff:** In most urbanized areas, drainage systems are designed to collect and convey storm water as efficiently as possible away from areas occupied by homes, businesses, and roadways. This efficiency tends to concentrate storm water runoff more quickly than the natural drainage system in most areas. In addition, re-grading of natural slopes and the removal of flow-retarding vegetation eliminates natural storage that attenuates runoff rates in non-urbanized areas. These factors cause runoff rates from urbanized areas to exceed rates from undeveloped areas, which tends to increase the water surface elevations (WSELs) in channels.
- **Modified Watershed Response:** The increased efficiency of urban drainage systems tends to decrease the time of concentration from developed drainage areas so that the peak runoff rate occurs more quickly than from the same area prior to development. As a result, development of a drainage area may adversely impact WSELs within the receiving channel due to changes in the timing of peak runoff rates. These adverse impacts may occur even if detention is provided and the developed peak runoff rate is less than the undeveloped peak runoff rate.
- **Reduced Flood Plain Conveyance:** Lots and/or building pads located in flood-prone areas are typically elevated with fill material. The placement of this material in flood plains creates obstructions to flow and reduces the available conveyance in the flood plain. The construction of elevated roads across the flood plain has a similar effect. Such reductions in the conveyance capacity of the flood plain tend to increase WSELs in channels.

### 3.5 Flood Insurance Concepts

The purpose of the NFIP, which is administered by the Federal Emergency Management Agency (FEMA), is to offer affordable flood insurance for homes and businesses located in flood-prone areas. Delineations of flood-prone areas are completed in Flood Insurance Studies (FIS) commissioned by individual participants (typically cities and counties) in the program. FEMA publishes the results of these studies as bound FIS and as Flood Insurance Rate Maps (FIRMs). The purpose of FIS is to define areas with a certain chance of flooding. The 100-year rainfall event, which has a one-percent probability of occurring in any given year, is used as a standard measure. However, FIS and FIRMs are

not intended to indicate with certainty that a particular area will or will not flood over a given period of time.

FIS include hydrologic studies to define peak flow rates along studied streams for 10-, 50-, 100-, and 500-year rainfall events. Hydraulic analyses are also performed to establish base flood elevations (BFEs) along studied streams for each of these rainfall events and to define the boundaries of the 100- and 500-year flood plains as well as the floodway. As shown on Exhibit 3-4, the floodway is a corridor of effective flow that includes the channel and any adjacent land areas required to pass the 100-year peak discharge rates without increasing the WSEL at any point along the channel more than one-foot above the 100-year BFEs. FIRMs provide data on 100-year BFEs, illustrate the boundaries of the floodway and 100- and 500-year flood plains, and designate flood hazard zones for insurance purposes (Exhibit 3-5). The irregular lines drawn across the 100-year flood plain at one-foot intervals indicate the BFEs along the stream.

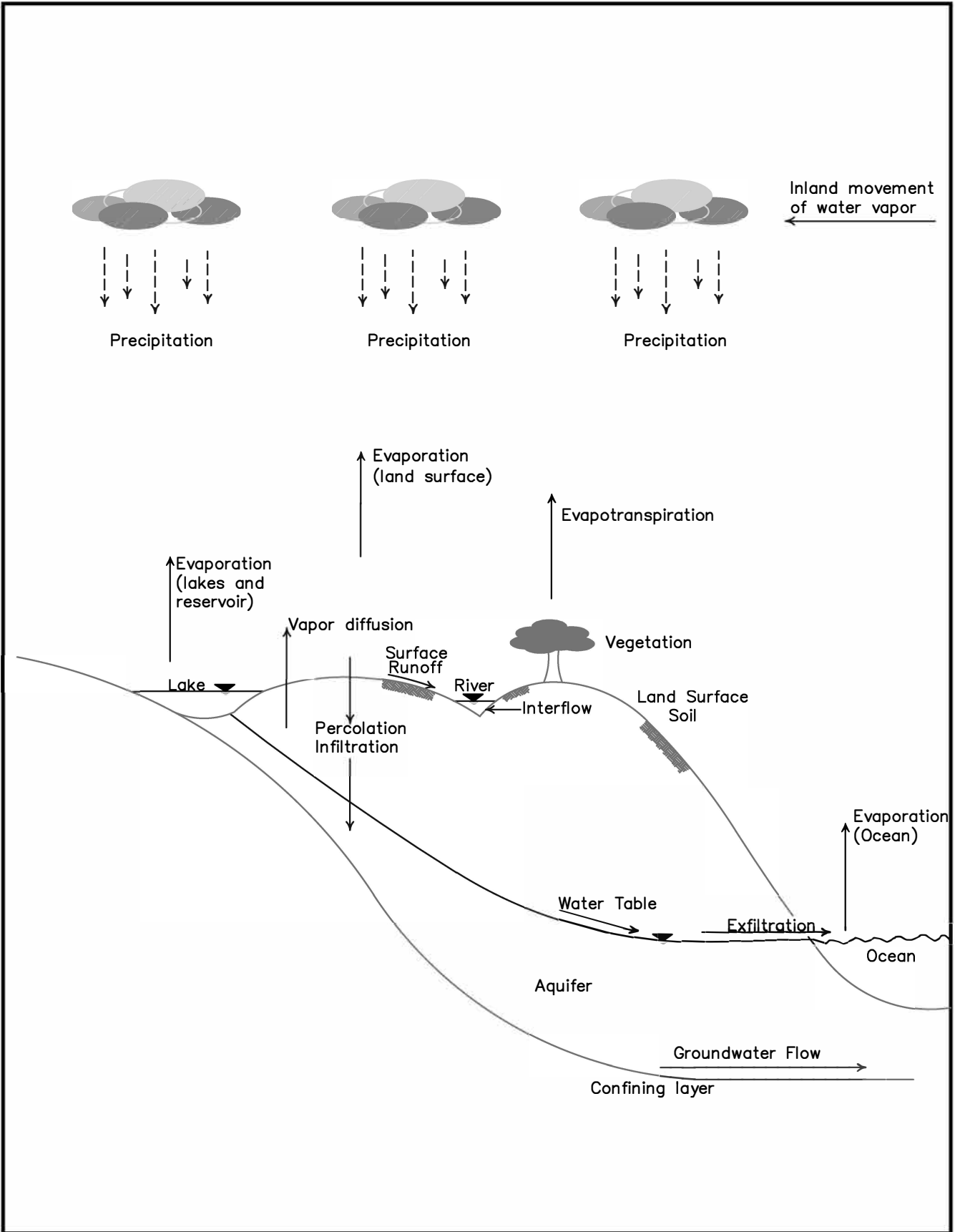

LIBERTY COUNTY WATER CONTROL IMPROVEMENT DISTRICT #5

THE HYDROLOGIC CYCLE

AUGUST 2016

EXHIBIT NO. 3-1

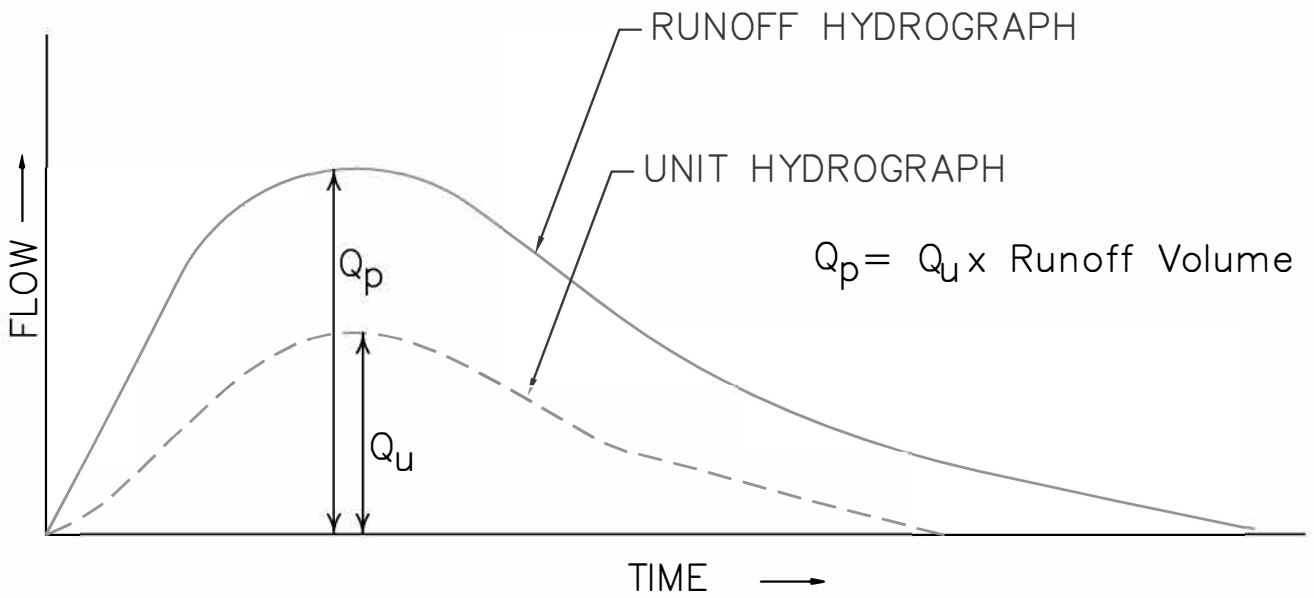

LIBERTY COUNTY WATER  
CONTROL IMPROVEMENT  
DISTRICT #5

RELATIONSHIP BETWEEN  
UNIT AND RUNOFF HYDROGRAPHS

DATE AUGUST 2016

EXHIBIT NO. 3-2

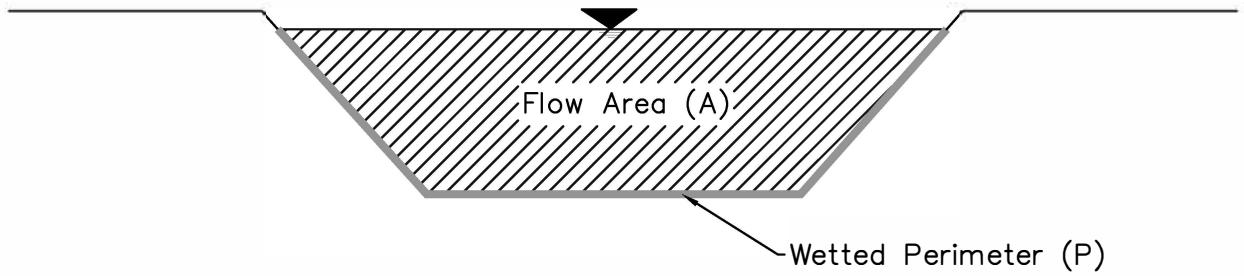

$$R = \frac{A}{P}$$

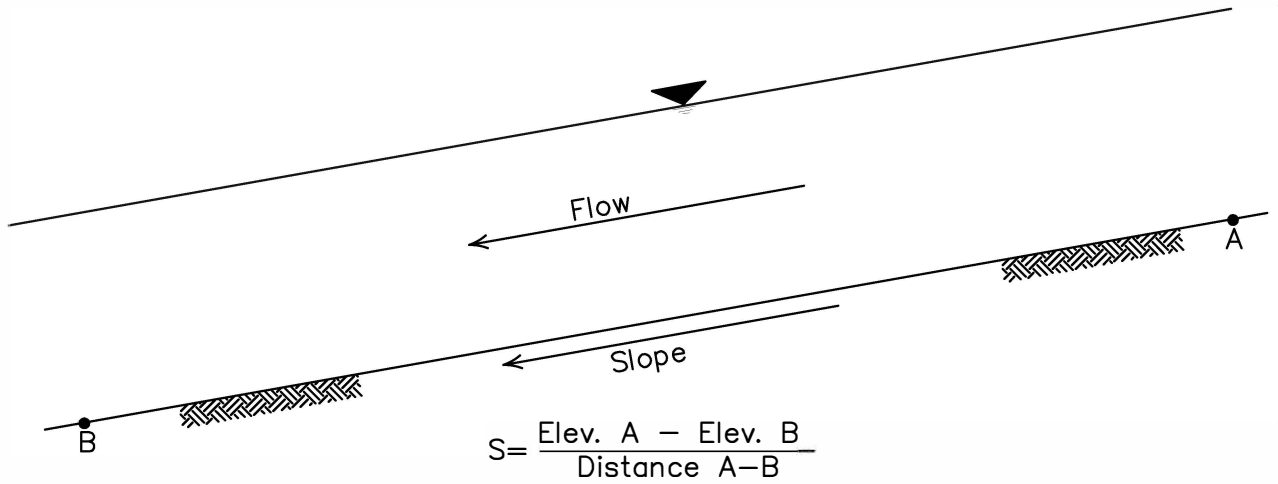

$$S = \frac{\text{Elev. A} - \text{Elev. B}}{\text{Distance A-B}}$$

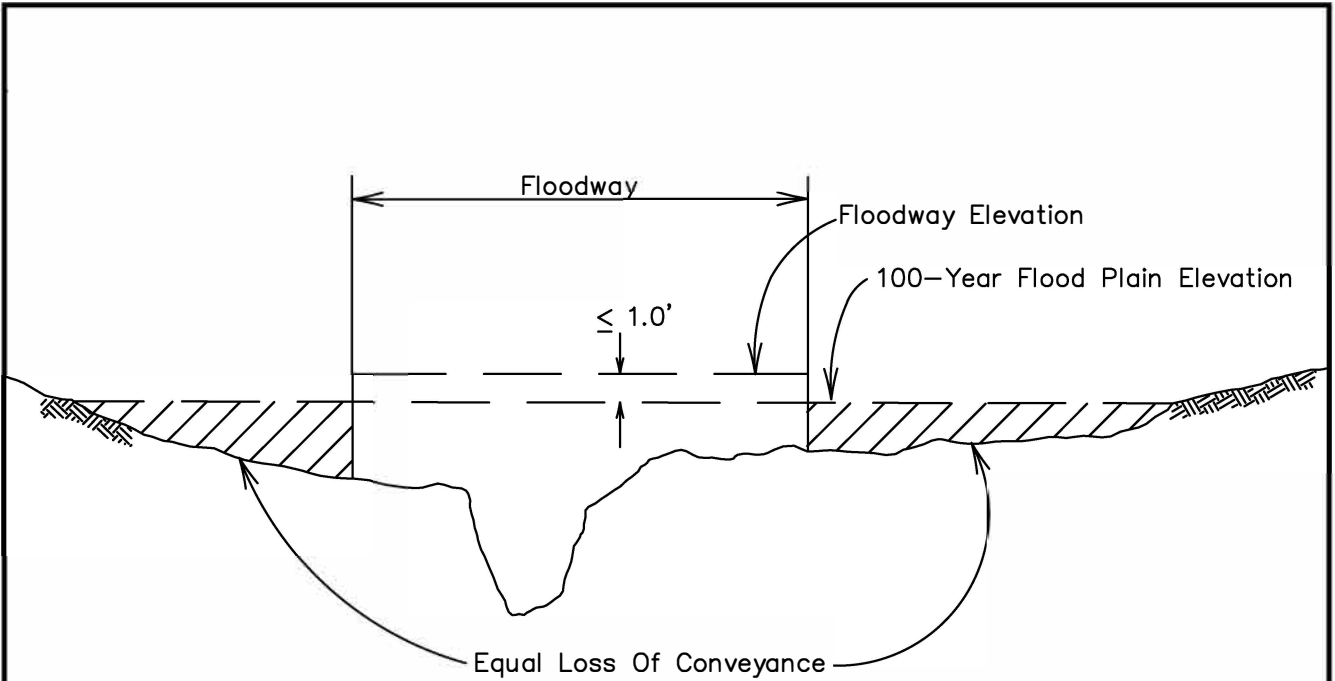

CHANNEL CROSS-SECTION A-A

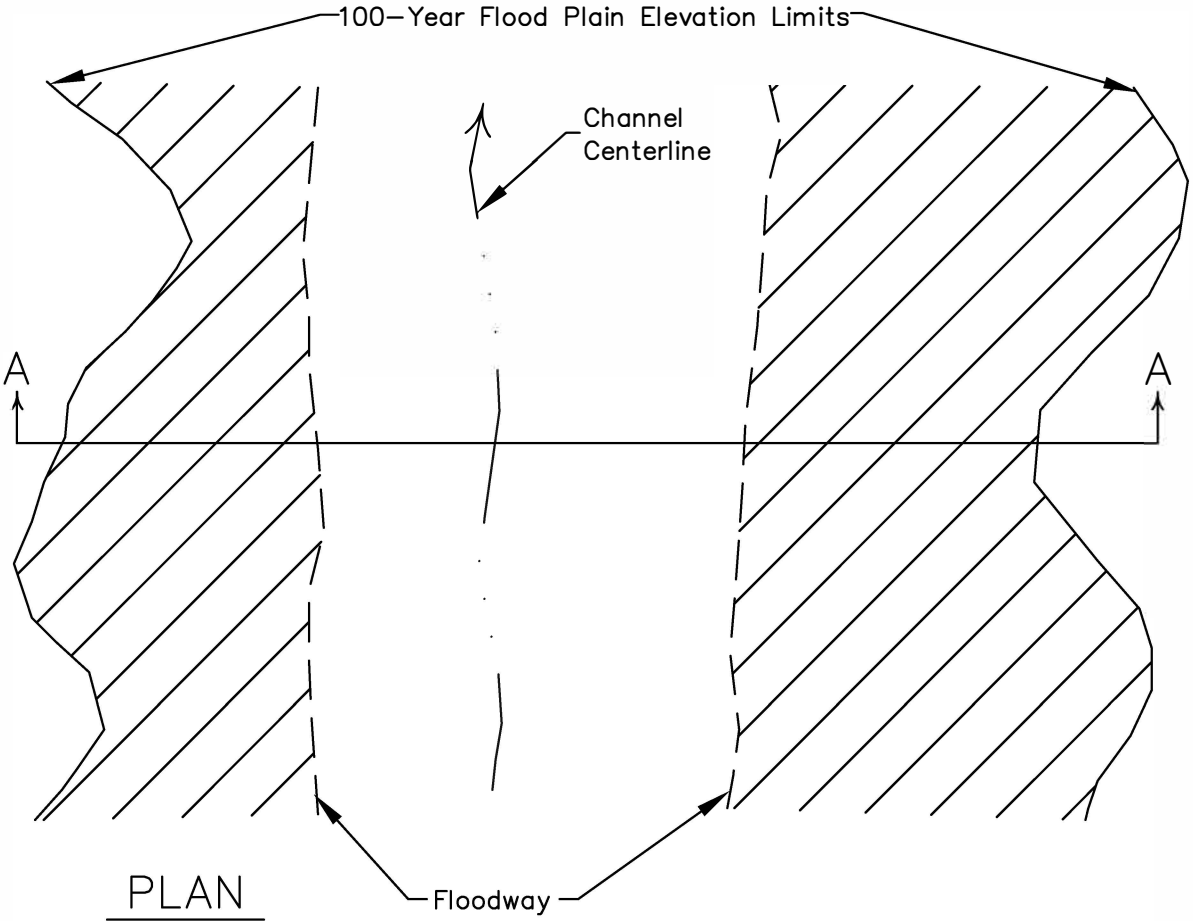

PLAN

LIBERTY COUNTY WATER  
CONTROL IMPROVEMENT  
DISTRICT #5

RELATIONSHIP BETWEEN THE  
100-YEAR FLOOD PLAIN AND FLOODWAY

DATE	AUGUST 2016	EXHIBIT NO.	3-4
------	-------------	-------------	-----



TYPICAL Liberty COUNTY  
FLOOD INSURANCE RATE MAP

DATE AUGUST 2016

EXHIBIT NO. 3-5



## 4 HYDROLOGY

The purpose of this chapter is to provide detailed information on the hydrologic analyses required by WCID #1. This chapter is divided into two main sections. Section 4.1 describes requirements for the hydrologic analysis of drainage areas up to 200 acres, while Section 4.2 describes requirements for the hydrologic analysis of drainage areas greater than 200 acres.

### 4.1 Drainage Areas up to 200 Acres

#### 4.1.1 Introduction

This section describes the methods to be used in hydrologic analyses of drainage areas up to 200 acres. These analyses may be completed using the Rational Method. However, a HEC-HMS hydrologic analysis can also be performed for drainage areas up to 200 acres using the methodology described in Section 4.2.

#### 4.1.2 The Rational Method

The Rational Method relates the runoff rate from a watershed to drainage area, land use, and rainfall intensity. The basic equation used in the Rational Method to compute the runoff rate is:

$$Q = C \times C_a \times I \times A \quad \text{Equation 4-1}$$

- where:
- $Q$  = the peak runoff rate (cubic feet per second);
  - $C$  = a runoff coefficient dependent on land use;
  - $C_a$  = a runoff coefficient adjustment factor dependent on the storm recurrence interval;
  - $I$  = the rainfall intensity (inches per hour);
  - $A$  = the drainage area (acres).

#### 4.1.3 Establishing the Drainage Area

Drainage areas for Rational Method analyses should be established using topographic maps, storm sewer layouts, and other available information. At each computation point, the drainage area is defined as the total area contributing runoff at that location.

#### 4.1.4 Determining Runoff Coefficients

Table 4-1 provides a summary of runoff coefficients for various land uses, overland slopes, and soil types. The appropriate runoff coefficient may be selected by establishing the land use and

consulting this table. For example, an area developed as an apartment complex on land which slopes at less than one-percent would have a runoff coefficient of 0.75. Land use data may be obtained from zoning maps, aerial photographs, and site visits.

Description of Area	Basin Slope		
	< 1%	1% - 3.5%	> 3.5%
Single-Family Residential Districts			
<i>Lots greater than 1/2 acre</i>	0.30	0.35	0.40
<i>Lots 1/4 to 1/2 acre</i>	0.40	0.45	0.50
<i>Lots less than 1/4 acre</i>	0.50	0.55	0.60
Multi-Family Residential Districts	0.60	0.65	0.70
Apartment Dwelling Areas	0.75	0.80	0.85
Business Districts			
<i>Downtown</i>	0.85	0.87	0.90
<i>Neighborhood</i>	0.75	0.80	0.85
Industrial Districts			
<i>Light</i>	0.50	0.65	0.80
<i>Heavy</i>	0.60	0.75	0.90
<i>Railroad Yard Areas</i>	0.20	0.30	0.40
<i>Cemeteries</i>	0.10	0.18	0.25
<i>Playgrounds</i>	0.20	0.28	0.35
Streets			
<i>Asphalt</i>	0.80	0.80	0.80
<i>Concrete</i>	0.85	0.85	0.85
<i>Concrete Drives and Walks</i>	0.85	0.85	0.85
<i>Roofs</i>	0.85	0.85	0.85
Lawn Areas			
<i>Sandy Soil</i>	0.05	0.08	0.12
<i>Clay Soil</i>	0.15	0.18	0.22
Woodlands			
<i>Sandy Soil</i>	0.15	0.18	0.25
<i>Clay Soil</i>	0.18	0.20	0.30
Pasture			
<i>Sandy Soil</i>	0.25	0.35	0.40
<i>Clay Soil</i>	0.30	0.40	0.50
Cultivated			
<i>Sandy Soil</i>	0.30	0.55	0.70
<i>Clay Soil</i>	0.35	0.60	0.80

For drainage areas with multiple land uses, runoff coefficients and drainage areas associated with each land use shall be determined. The composite runoff coefficient shall then be computed using Equation 4-2:

$$C_w = \sum \frac{(C_i \times A_i)}{A_T} \quad \text{Equation 4-2}$$

where:  $C_w$  = weighted runoff coefficient;  
 $C_i$  = runoff coefficients for various land uses;  
 $A_i$  = drainage areas corresponding to values of  $C_i$  (acres);  
 $A_T$  = total drainage area (acres).

As indicated previously, a runoff coefficient adjustment factor ( $C_a$ ) shall be used to adjust peak runoff rates for various recurrence intervals. Table 4-2 lists the runoff coefficient adjustment factors for storm recurrence intervals ranging from two to 100 years.

<b>TABLE 4-2: RATIONAL METHOD RUNOFF COEFFICIENT ADJUSTMENT FACTORS</b>	
<b>Storm Recurrence Interval (years)</b>	<b>Adjustment Factor (<math>C_a</math>)</b>
2 - 10	1.00
25	1.10
50	1.20
100	1.25

#### 4.1.5 Establishing the Time of Concentration

The time of concentration ( $T_C$ ) is defined as the time (in minutes) required for all portions of the watershed to contribute runoff at the computation point. The  $T_C$  is normally calculated by identifying the longest flow path within the watershed and estimating the time required for runoff to travel the entire length of this path. Storm water runoff may pass through a range of flow conditions as it moves along the longest flow path. Overland sheet flow is characterized by very shallow depths of less than two inches. Within a short distance of about 100 to 300 feet, storm water runoff begins to flow at greater depths to collect in streets, swales, and small ditches or gullies, and is commonly known as concentrated overland flow. Finally, the runoff collects in storm sewers, creeks, and drainage channels in which flow depths may reach several feet.

In order to estimate  $T_C$ , the longest flow path is divided into reaches that represent the various types of flow conditions and the flow velocity for each individual reach is estimated. For

example, the longest flow path may include overland sheet flow, concentrated flow in a roadside ditch, and flow in a drainage channel. Flow velocities for overland sheet flow and some concentrated flow conditions may be estimated using the Uplands Method, which relates flow velocity to overland slope and land use. This method was developed by the U.S. Department of Agriculture Soil Conservation Service (SCS). Exhibit 4-1 provides a graphical representation of the Uplands Method.

For storm sewers, creeks, and channels, flow velocities may be estimated using Manning's equation or a HEC-RAS model (see Chapter 5). The length of each individual reach is divided by the flow velocity to obtain the time of travel required for water to pass through the reach, and  $T_C$  is calculated as the sum of the individual travel times.

#### 4.1.6 Computation of Rainfall Intensity

The rainfall intensity ( $I$ ) for a particular frequency used in the Rational Method may be determined from Equation 4-3, which was developed by the Texas Department of Transportation (TxDOT) based on United States Geological Survey (USGS) Scientific Investigation Report 2004-5041 "Atlas of Depth-duration Frequency of Precipitation Annual Maxima for Texas"

$$I = \frac{b}{(T_C + d)^e} \quad \text{Equation 4-3}$$

where:  $I$  = rainfall intensity (inches per hour);

$T_C$  = time of concentration (minutes)

$b, d, e$  = rainfall intensity parameters from Table 4-3.

If the calculated  $T_C$  is less than 10 minutes, then a  $T_C$  of 10 minutes should be used in Equation 4-3.

<b>TABLE 4-3: RAINFALL INTENSITY PARAMETERS</b>			
<b>CONSTANTS FOR LIBERTY COUNTY, TEXAS</b>			
<b>Storm Frequency</b>	<b><math>e</math></b>	<b><math>b</math> (in)</b>	<b><math>d</math> (min)</b>
2-Year	0.785	59	11.5
5-Year	0.780	75	12.7
10-Year	0.774	85	13.0
25-Year	0.774	103	14.4
50-Year	0.767	115	15.2
100-Year	0.765	131	16.4

### 4.1.7 Analyzing a Watershed with Multiple Sub-Areas or Computation Points

When analyzing a watershed with multiple sub-areas or computation points, the peak flow rate at the computation point located furthest upstream is computed first. Peak flow rates are computed at subsequent points, while moving in the downstream direction. At each point, the total drainage area is determined and  $T_C$  is computed for the longest flow path from the most remote point in the entire watershed to the current computation point. Exhibit 4-2 shows a typical layout of a small watershed with multiple sub-areas and computation points. The rainfall intensity for the peak flow rate computation is calculated using this  $T_C$ . As discussed in Section 4.1.4, a weighted runoff coefficient shall be computed using the coefficients for individual sub-areas upstream of the computation point.

## 4.2 Drainage Areas Greater than 200 Acres

This section describes the methods to be used in hydrologic analyses of drainage areas greater than 200 acres. These analyses shall be completed using the HEC-HMS computer program developed at the Hydrologic Engineering Center of the U.S. Army Corps of Engineers (USACE). This software program can be downloaded from the USACE's website (<http://www.hec.usace.army.mil/software/hechms/hechms-download.html>) at no charge. The *Hydrologic Modeling System HEC-HMS User's Manual*, the *Hydrologic Modeling System HEC-HMS Applications Guide*, and the *Hydrologic Modeling System HEC-HMS Technical Reference Manual* developed by the USACE can be used for further reference. These manuals can also be downloaded from the USACE's website (<http://www.hec.usace.army.mil/software/hechms/hechms-document.html>) at no charge. The hydrologic parameters discussed in Sections 4.2.1 to 4.2.5 are the basis for developing HEC-HMS models.

### 4.2.1 Watershed Boundaries

Topographic information, storm sewer layouts, and other available information shall be used to provide the level of detail necessary to delineate additional sub-area boundaries as needed. These boundaries may be delineated by hand or with HEC-GeoHMS, which is a *Geographic Information Systems (GIS)* program that works in conjunction with ArcView to compute hydrologic parameters. However, HEC-GeoHMS sub-area boundaries should be closely reviewed by an engineer familiar with the topography of the drainage area. The number of sub-areas required for the HEC-HMS analysis is a function of the number of computation points, which are typically established at confluences with tributaries, roadway crossings, or other points of interest (lakes and reservoirs, etc.). Normally, there is one sub-area above the first analysis point and one or more between

each pair of successive analysis points. In addition, there is at least one sub-area for each tributary.

#### 4.2.2 Rainfall Data

The rainfall depth-duration-frequency data for the Liberty County WCID #1 listed in Table 4-4, which was developed by modifying data contained in the *USGS Scientific Investigations Report 2004-5041*, shall be used in HEC-HMS hydrologic analyses. Exhibit 4-3 illustrates the IDF curves developed from this data. The rainfall depth data and exceedance probability associated with the design storm event shall be entered in the meteorological model of HEC-HMS. A one-percent exceedance probability would be entered for a 100-year storm event, four-percent would be entered for a 25-year event, and twenty-percent would be entered for a 5-year event.

A maximum intensity-duration of five minutes shall be used for the analysis regardless of the design storm event. A value of 67-percent is used as the peak center and the HEC-HMS program automatically distributes the rainfall over a 24-hour period in such a manner that the maximum rainfall intensity occurs at approximately two-thirds of storm event. Rainfall leading up to and following the period of maximum intensity is distributed in a manner which produces a balanced rainfall distribution. Since the use of the total area option in HEC-HMS is problematic for many types of hydrologic analysis, point rainfall data is used in WCID #1 and a total storm area of 0.01 square miles, or other approved area, is used to compute runoff hydrographs. A baseflow of zero shall be used unless project-specific considerations warrant the use of this parameter.

Recurrence	Rainfall Depth (inches) for Given Duration							
	15 min	30 min	60 min	2 hour	3 hour	6 hour	12 hour	24 hour
2	1.1	1.6	2.0	2.6	2.9	3.4	4.1	4.8
5	1.4	1.9	2.6	3.5	3.8	4.7	5.7	6.8
10	1.5	2.2	3.0	4.1	4.5	5.6	6.8	8.2
25	1.8	2.4	3.5	4.9	5.4	7.0	8.7	10.0
50	2.0	2.7	3.9	5.7	6.4	8.4	10.5	11.8
100	2.2	2.9	4.4	6.5	7.4	10.0	12.4	13.4
500	2.6	3.5	5.7	8.7	10.2	14.9	18.4	19.1

### 4.2.3 Infiltration Losses

Infiltration losses shall be accounted for using the Green & Ampt method, which is a conceptual representation of the infiltration process, was developed in 1911 by Green & Ampt. This method estimates infiltration losses based on a function of soil texture and the capacity of the given soil type to convey water. The advantage of this method is that the parameters can be estimated based on soil type. The parameters should be applied on a watershed-wide basis, similar to the exponential and initial/uniform loss methods from the original Flood Hazard Study.

Table 4-5 shows the volume moisture deficit, wetting front suction, and hydraulic conductivity parameters for various soil textures and types. The hydrologic soil group to which a particular soil belongs may be determined by consulting the Soil Survey or the Soil Survey Geographic Database (SSURGO) for WCID #1, Texas.

<b>TABLE 4-5: GREEN &amp; AMPT LOSS PARAMETERS</b>			
<b>Soil Classification</b>	<b>Volume Moisture Deficit</b>	<b>Wetting Front Suction (inches)</b>	<b>Hydraulic Conductivity (inches/hour)</b>
<b>Soil Texture</b>			
Sand	0.417	1.95	9.276
Loamy Sand	0.402	2.41	2.354
Sandy Loam	0.412	4.33	0.858
Loam	0.436	3.50	0.520
Silt Loam	0.486	6.57	0.268
Sandy Clay Loam	0.330	8.60	0.118
Clay Loam	0.389	8.22	0.079
Silty Clay Loam	0.431	10.75	0.079
Sandy Clay	0.321	9.41	0.047
Silty Clay	0.423	11.50	0.039
Clay	0.385	12.45	0.024
<b>Soil Group</b>			
A (freely draining)	0.417	1.95	9.276
B (intermediate)	0.436	3.50	0.520
C (intermediate)	0.389	8.22	0.079
D (poorly draining)	0.385	12.45	0.024

#### 4.2.4 Initial Abstraction

Initial abstraction losses shall be accounted for using the Soil Conservation Service (SCS) Curve Number method, which is an empirical method developed by the U.S. Department of Agriculture. Equation 4-4 can be used to compute the initial abstraction for specific soil types.

$$I_a = 0.2S \quad \text{Equation 4-4}$$

where:  $I_a$  = the initial abstraction depth (inches);

$$S = \text{initial retention} = \frac{1000}{CN} - 10;$$

$CN$  = SCS Curve Number, from Table 4-6.

The Curve Number is a function of soil structure, antecedent watershed moisture, and land use. Soil structure is defined by assigning individual soils to one of four hydrologic soil groups (A through D) that represent a wide range of soil porosities. Soils belonging to hydrologic soil group A are the most porous, while soils in group D are the least porous. The hydrologic soil group may be determined from the Soil Survey for WCID #1 area, Texas or the Soil Survey Geographic Database (SSURGO) for Liberty County. Table 4-6 provides a summary of SCS Curve Numbers for various land uses, taken from the *SCS National Engineering Handbook, Section 4*.



<b>Land Use Description</b>	<b>Hydrologic Soil Group</b>			
	<b>A</b>	<b>B</b>	<b>C</b>	<b>D</b>
Cultivated Land				
<i>Without Conservation Treatment</i>	72	81	88	91
<i>With Conservation Treatment</i>	62	71	78	81
Pasture or Range Land				
<i>Poor Condition</i>	68	79	86	89
<i>Good Condition</i>	39	61	74	80
Meadow: Good Condition	30	58	71	78
Wood or Forest Land				
<i>Thin Stand, Poor Cover, No Mulch</i>	45	66	77	83
<i>Good Cover</i>	25	55	70	77
Open Spaces, Lawns, Parks, Cemeteries				
<i>Good Condition, 75% Grass Cover</i>	39	61	74	80
<i>Poor Condition, 50-75% Grass Cover</i>	49	69	79	84
Commercial and Business Areas (85% Impervious)	89	92	94	95
Industrial Districts (72% Impervious)	81	88	91	93
Residential				
<i>Average Lot Size</i> <i>Average % Impervious</i>				
<i>1/8 acre or less</i> <i>65</i>	77	85	90	92
<i>1/4 acre</i> <i>38</i>	61	75	83	87
<i>1/3 acre</i> <i>30</i>	57	72	81	86
<i>1/2 acre</i> <i>25</i>	54	70	80	85
<i>1 acre</i> <i>20</i>	51	68	79	84
Paved Parking Lots, Roofs, Driveways, Etc.	98	98	98	98
Streets and Roads				
<i>Paved with Curbs and Storm Sewers</i>	98	98	98	98
<i>Gravel</i>	76	85	89	91
<i>Dirt</i>	72	82	87	89

Source: SCS National Engineering Handbook, Section 4

For watersheds with varying land uses and soil types, composite Curve Numbers may be computed by determining the Curve Number and drainage area associated with each land use and/or soil category. The composite Curve Number may then be computed using the following equation:

$$CN_w = \sum \frac{(CN_i \times A_i)}{A_T} \quad \text{Equation 4-5}$$

where:  $CN_w$  = weighted Curve Number;  
 $CN_i$  = Curve Number for various land uses and soil types;  
 $A_i$  = drainage areas corresponding to values of  $CN_i$  (acres);  
 $A_T$  = total drainage area (acres).

In HEC-HMS applications, cumulative totals for rainfall and infiltration are maintained. The total runoff is re-computed for every time step.

#### 4.2.5 Percent Impervious Cover

Percent impervious cover is a function of land urbanization and can be estimated from field observations, aerial photographs, and other supporting information on the drainage area. Table 4-7 provides a summary of percent impervious cover values for different land use categories:

Land Use Categories	Land Use Descriptions	% Impervious
Undeveloped	Unimproved, natural, or agricultural	0
Residential – Rural Lot	≥ 5-acre ranch or farm	5
Residential	Average Lot Size	
	1 acre	20
	1/2 acre	25
	1/3 acre	30
	1/4 acre	38
	1/8 acre or less	65
Developed Green Areas	Parks or golf courses	15
Light Industrial/ Commercial	Office parks, nurseries, airports, warehouses, or manufacturing with non-paved areas	60
High Density	Commercial, business, industrial, or apartments	85
Transportation	Highway or major thoroughfare corridors	90
Water	Detention basins, lakes, channels, roadside ditches	100

## 4.2.6 Loss Rate Computations in HEC-HMS

The Green & Ampt loss rate parameters and percent impervious cover values discussed in Sections 4.2.3 to Section 4.2.5 are entered into the loss rate option of the HEC-HMS Subbasin.

## 4.2.7 Unit Hydrograph Methodology

Unit hydrographs shall be computed based on the Clark Unit Hydrograph method, which is one of the unit hydrograph methods available in HEC-HMS. The Clark Unit Hydrograph method uses three parameters to define a unit hydrograph for a watershed: the  $T_C$ , a storage coefficient, and a time-area curve. The  $T_C$  is defined as the time required for all portions of the watershed to contribute runoff at the computation point. Refer to Section 4.1.5 for more information on estimation of  $T_C$ . The storage coefficient ( $R$ ) is an indicator of the available storm water storage volume within a watershed within depressions, ponds, channels and flood plains. The value of  $R$  varies directly with the relative amount of storage volume within a watershed (i.e., the greater the storage volume, the higher the storage coefficient). For WCID #1,  $R$  should be estimated from Equation 4-6 or any other methodology approved by WCID #1.

$$R = 3 \times T_C \qquad \text{Equation 4-6}$$

The time-area curve relates the percentage of the watershed contributing runoff at the analysis point to the fraction of the  $T_C$ , which has elapsed since the beginning of runoff. The entire watershed is considered to be contributing runoff at the outlet when the elapsed time is equal to or greater than the  $T_C$ . This standard curve is applicable as long as extremes in watershed shapes (i.e., very large or very small ratios of watershed length to width) are avoided. Calculation of the time-area curve is handled internally by HEC-HMS with a standard time-area curve based on assumed watershed shape.

Runoff hydrographs can be computed in HEC-HMS by selecting the Clark Unit Hydrograph method from the Transform option of HEC-HMS Subbasin Editor Window. In addition, the  $T_C$  and  $R$  parameters should be entered for each subbasin. The meteorological model data works in conjunction with the subbasin editor data to calculate a hydrograph for each subbasin.

## 4.2.8 Streamflow Routing

Streamflow routing is the process by which the lagging and attenuating effects of travel time and storage on runoff hydrographs are taken into account as flood flows move from one analysis point to another. Although the HEC-HMS program offers a number of streamflow routing methods, WCID #1 requires the use of the Modified Puls method where channel cross-

sections and a HEC-RAS hydraulic model of the channel are available. For streamflow routing along channels without a HEC-RAS model, the Muskingum-Cunge Standard, Muskingum-Cunge 8-Point, or Muskingum methods should be used depending on which method is best suited to the specific application. However, if backwater conditions and/or overland flooding are anticipated, it is recommended that a HEC-RAS model of the channel be developed and the Modified Puls method be used.

The Modified Puls Method explicitly accounts for the effects of storage volume within the flood plain and is based on a simple continuity equation:

$$\Delta S = I - O \quad \text{Equation 4-7}$$

where:  $\Delta S$  = change in storage volume within the routing reach;  
 $I$  = inflow to the routing reach;  
 $O$  = outflow from the routing reach.

For the Modified Puls method, input to the HEC-HMS program consists of a set of flow rates and corresponding storage volumes, which are input in the basin model routing reach window. Additionally, the number of sub-reaches and initial flow condition are selected in the same window. The Muskingum method is an approximation of the continuity equation (Equation 4-7) where storage is modeled as the sum of prism and wedge storage. Required input parameters for this method include: the Muskingum K, Muskingum X (ranges from 0.0 to 0.5), and the number of sub-reaches. Refer to the HEC-HMS documentation.

HEC-HMS modeling input for the Muskingum-Cunge Standard method consists of the following physical parameters: the length and slope of the routing reach, the Manning's roughness coefficient (n value), the shape of the channel (circular or prismatic), the bottom width or diameter, and the side slope ratio. This mathematical routing method provides an implicit accounting of storage within the channel. However, storage within the flood plain outside the defined channel is not considered. Although the same equations and solution techniques are used for the Muskingum-Cunge 8-Point method, the channel is described with eight station-elevation coordinates instead of a standard cross-section shape. Other required input items for this method are the reach length, energy slope, and n values for the channel and overbanks.

#### 4.2.9 Combining Hydrographs

When analyzing Basins or subbasins that have been divided into two or more sub-areas, it is necessary to combine runoff hydrographs from the individual sub-areas. Combining the

hydrographs yields a single hydrograph, which accounts for all the runoff from the individual sub-areas. This is accomplished by inserting a junction in the HEC-HMS Basin Model. Connect the two sub-areas to the junction to obtain a combined hydrograph.

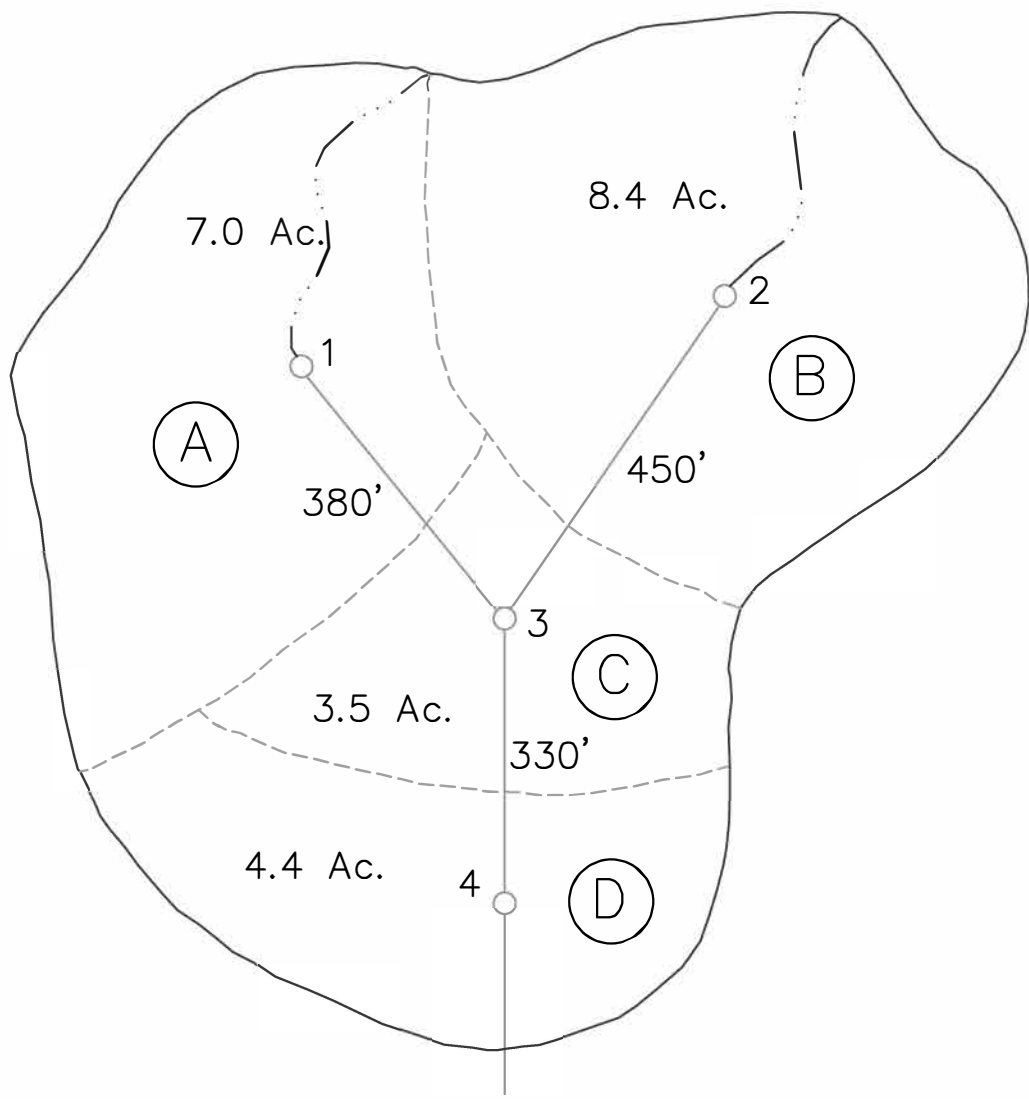

**WATERSHED WITH  
MULTIPLE SUB-AREAS**

DATE AUGUST 2016

EXHIBIT NO. 4-2

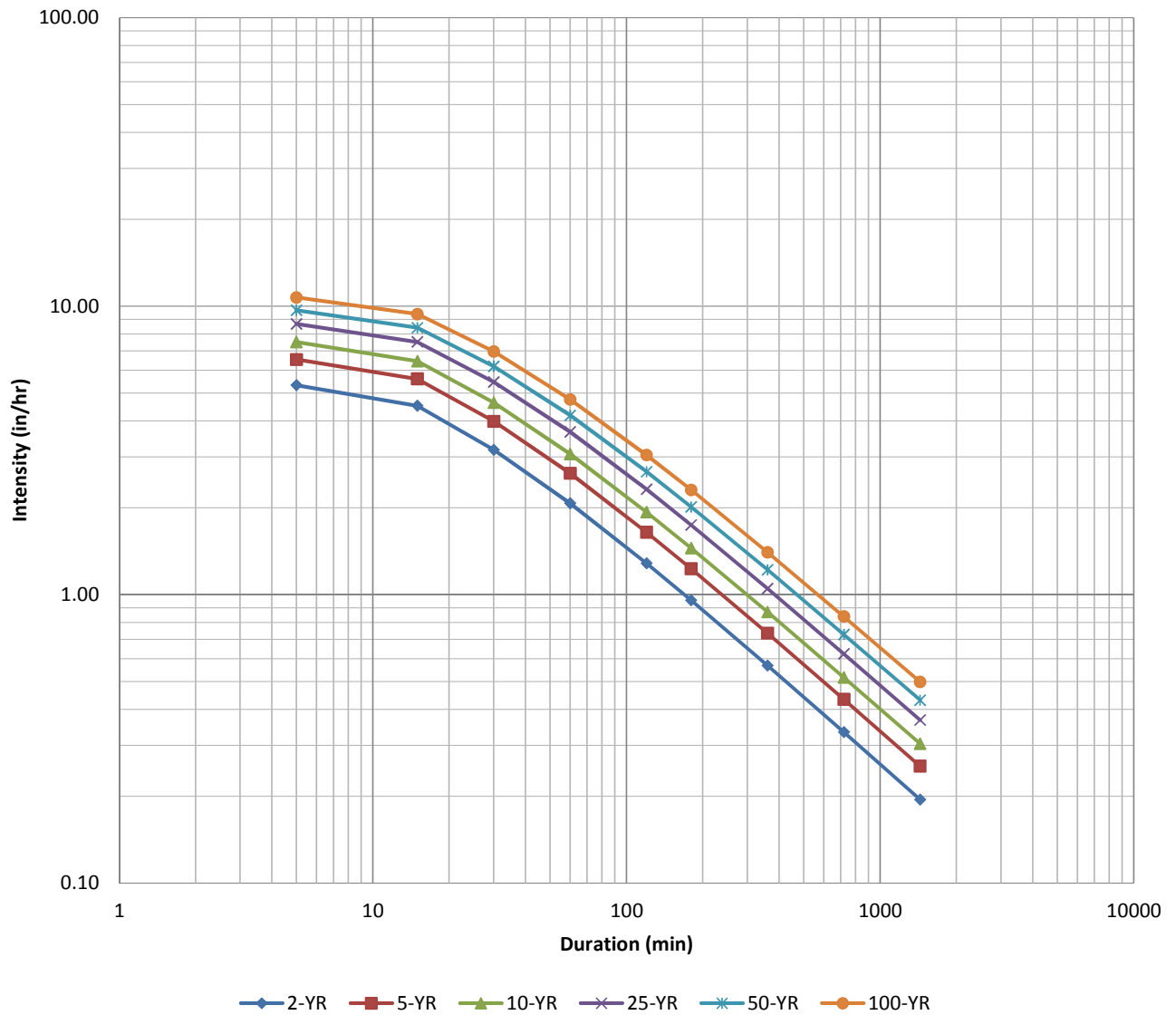

LIBERTY COUNTY WATER  
CONTROL IMPROVEMENT  
DISTRICT

USGS SIR 2004-5041  
IDF CURVES FOR LIBERTY COUNTY

DATE AUGUST 2016

EXHIBIT NO. 4-3

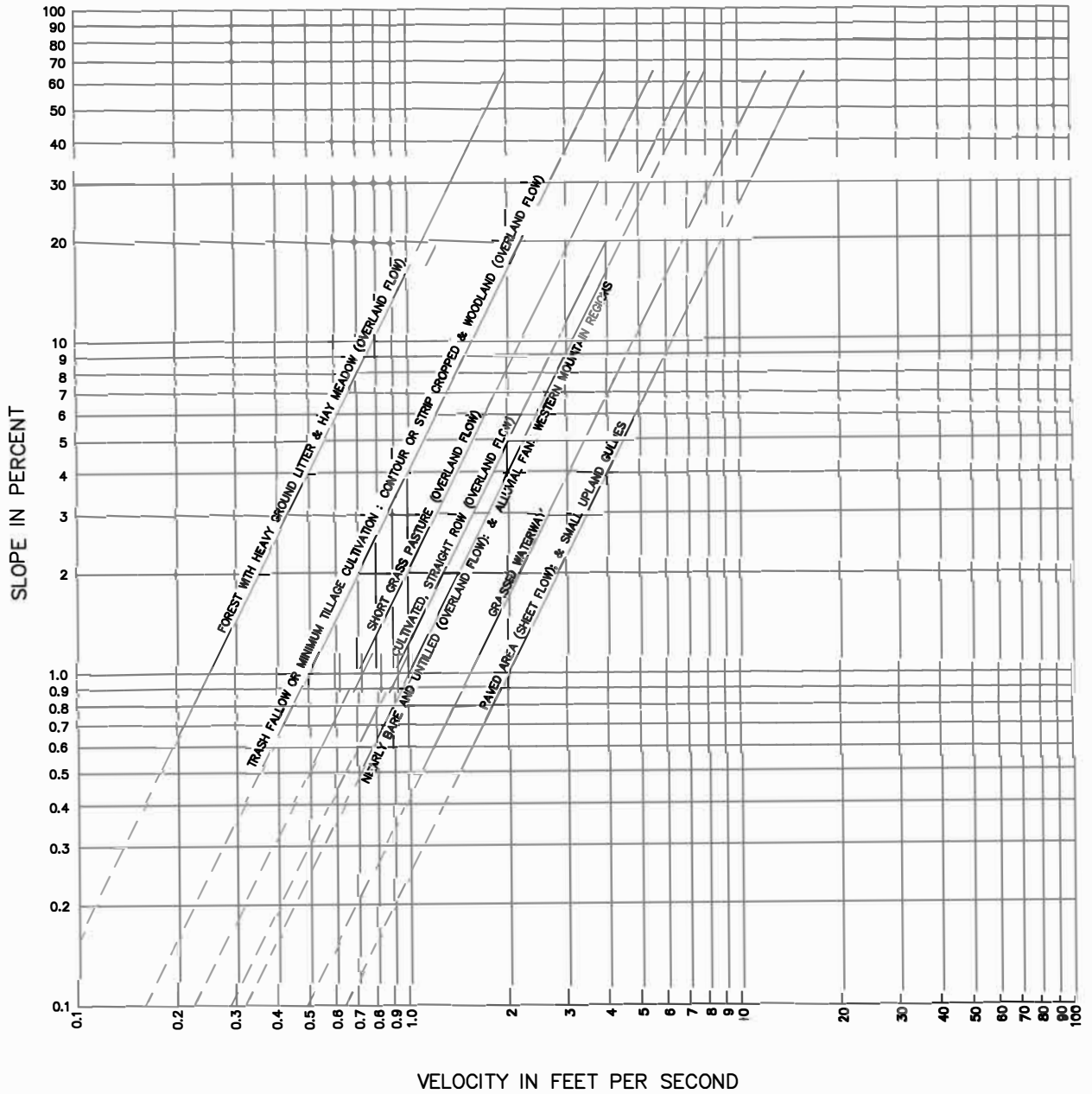

LIBERTY COUNTY WATER  
CONTROL IMPROVEMENT  
DISTRICT #1

### SCS UPLANDS METHOD

DATE AUGUST 2016

EXHIBIT NO. 4-1



## 5 HYDRAULICS OF PRIMARY DRAINAGE FACILITIES

The purpose of this chapter is to provide detailed information on the hydraulic analysis and design of primary drainage facilities within WCID #1. As indicated in Chapter 1, the primary drainage facilities include open channels, bridges, culverts, and enclosed drainage systems (i.e., open channels that have been enclosed).

### 5.1 General Design Requirements for Primary Drainage Facilities

The following design requirements are discussed in this section: design storm frequencies; design requirements for earthen channels; design requirements for concrete-lined channels; design requirements for rectangular concrete low-flow sections; transitions, bends, and confluences; design requirements for culverts; structural requirements for culverts; design requirements for bridges; design requirements for enclosed systems; and maximum allowable velocities.

#### 5.1.1 Design Storm Frequencies

The following design storm frequencies shall be used for analysis and design of open channels, bridges, culverts, and enclosed systems:

- Channels draining up to 100 acres shall be designed to convey 25-year peak discharges with a minimum freeboard of one foot.
- Channels draining between 100 acres and 200 acres shall be designed to convey 50-year peak flow rates a minimum freeboard of one foot.
- Channels draining greater than 200 acres shall be designed to convey 100-year peak flow rates a minimum freeboard of one foot. These channels shall also be analyzed using a 10-year design storm event.
- For open channel studies involving *Federal Emergency Management Agency (FEMA)* submittals, the 10-year, 50-year, 100-year, and 500-year storm frequencies must be analyzed.

#### 5.1.2 Design Requirements for Earthen Channels

The following minimum requirements shall be incorporated into designs of earthen channels:

- Channel side slopes shall be no steeper than 3 horizontal to 1 vertical (3:1). Flatter slopes may be required when soil conditions are conducive to slope instability.
- The minimum channel bottom width shall be six feet.

- A maintenance berm is required on both sides of the channel. For channels with top widths of 30 feet or less, the minimum maintenance berm width is 15 feet. For top widths between 30 feet and 60 feet, 20-foot maintenance berms are required. For channels with top widths greater than 60 feet, the minimum maintenance berm width is 30 feet.
- Backslope drain swales and interceptor structures are required to prevent flow down the ditch side slopes. The maximum spacing for interceptor structures is 600 feet.
- Channels, channel rights-of-way (ROWs) and side slopes must be vegetated immediately after construction to minimize erosion in accordance with the erosion control requirements discussed in Chapter 8.
- Flow from roadside ditches must be conveyed into open channels through standard roadside ditch interceptor structures as described in Chapter 8.
- A geotechnical investigation and report on local soil conditions is required for all channel construction and improvement projects.

Exhibit 5-1 illustrates a typical design cross-section for a trapezoidal earthen channel.

### 5.1.3 Minimum Design Requirements for Trapezoidal Concrete-Lined Channels

Concrete-lined channels shall be designed to meet the following minimum requirements:

- All concrete slope paving shall consist of Class A concrete.
- The minimum bottom width shall be eight feet.
- The side slopes of the channel shall be no steeper than 1.5 horizontal to 1 vertical (1.5:1).
- A maintenance berm is required on both sides of the channel. The berm width shall be at least 20 feet on one side of the channel and at least 10 feet on the other side.
- All slope paving shall include a toe wall at the top and sides with a minimum depth of 18 inches. Toe walls shall also be included along the bottom of the channel with a minimum depth of 24 inches for clay soils and 36 inches for sandy soils.
- Backslope drain swales and interceptor structures are required in the channel maintenance berm to prevent overland flow down the bank of partially-lined channels. These items shall be designed in accordance with the minimum requirements specified in Chapter 8. However, backslope drain swales and interceptor structures are not required on fully lined channels.

- Channel maintenance berms must be vegetated immediately after construction in accordance with erosion control requirements discussed in Chapter 8.
- Weep holes shall be used to relieve hydrostatic pressure behind lined channel sections. The specific type, size, and placement of the weep holes shall be based on the recommendations of the geotechnical report.
- Where construction is to take place under muddy conditions or where standing water is present, a seal slab of Class C concrete shall be placed in the channel bottom prior to placement of the concrete slope paving.
- Control joints shall be provided at a maximum spacing of approximately 25 feet. A sealing agent shall be utilized to prevent moisture infiltration at control joints.
- Concrete slope protection shall have the minimum thickness and reinforcement indicated in Table 5-1.
- A geotechnical investigation and report on local soil conditions is required for all channel construction and improvement projects.

Exhibit 5-2 illustrates a typical design cross-section for a trapezoidal concrete-lined channel.

<b>TABLE 5-1: MINIMUM THICKNESS AND REINFORCEMENT FOR CONCRETE SLOPE PAVING</b>			
<b>Channel Side Slope (H:V)</b>	<b>Minimum Thickness (inches)</b>	<b>Minimum Reinforcement</b>	
		<b>Material</b>	<b>Dimensions</b>
3:1	4 inches	welded wire fabric	6 x 6 x W2.9 x W2.9
2:1	5 inches	welded wire fabric	6 x 6 x W4.0 x W4.0
1.5:1	6 inches	reinforcement	4 x 4 x W4.0 x W4.0

#### 5.1.4 Design Requirements for Rectangular Concrete Low-Flow Sections

As shown on Exhibit 5-3, rectangular concrete low-flow sections can be incorporated into designs for earthen and concrete-lined channels to provide additional capacity or depth in areas where channel ROW is limited. The following criteria shall be used for concrete low-flow sections:

- All concrete slope paving shall consist of Class A concrete.
- The structural steel design should be based on the use of ASTM A-615, Grade 60 steel.

- The minimum bottom width of the low-flow section shall be eight feet.
- For bottom widths of 12 feet or more, the channel bottom shall be graded toward the centerline at a slope of 1/2 inch per foot (4.15-percent).
- The maximum height of vertical concrete walls shall be three (3) feet.
- Escape stairways shall be located at the upstream side of all roadway crossings. Additional escape stairways shall be located along the channel to keep the maximum distance between stairways below 1,400 feet between stairways.
- For channels with concrete low-flow sections, the top of the vertical concrete wall shall be constructed in such a way as to provide for the possible future placement of concrete slope paving. Culverts shall be aligned parallel to the longitudinal axis of the channel to maximize hydraulic efficiency and minimize turbulence and erosion. At locations where a difference between the alignment of the channel and the culvert is necessary, the change in alignment shall be accomplished upstream of the culvert so that the culvert is aligned with the downstream channel.
- The minimum allowable diameter for circular culverts is 24 inches.
- The minimum allowable size of box culverts is two feet x two feet.
- Concrete slope paving or riprap shall be used upstream and downstream of the culvert to protect earthen channels from erosion.
- Culverts shall extend completely across road and railroad ROWs at crossing locations.
- Where hydraulic jumps are anticipated around culverts, the channel geometry shall be modified to force the hydraulic jump to occur in a portion of the channel protected with concrete slope paving. Hydraulic jumps are characterized by a rapid change in the depth of flow from a low stage to a high stage, which results in an abrupt rise in the WSEL.

### 5.1.5 Structural Requirements for Culverts

Unless otherwise approved, all pipe and box culverts shall satisfy the following minimum structural design requirements:

- All pre-cast reinforced concrete pipe shall be ASTM C-76.
- All high density polyethylene (HDPE) pipe culverts shall conform to the AASHTO M294 specifications. Bedding for HDPE culverts shall be designed and constructed in accordance with the manufacturer's recommendations.

- All pre-cast reinforced concrete box culverts with more than two feet of earthen cover shall be ASTM C789-79. All pre-cast reinforced box culverts with less than two feet of earthen cover shall be ASTM 850-79.
- All corrugated steel pipes shall be aluminized in accordance with AASHTO M-36.
- AASHTO HS20-44 loading shall be used for all culverts.
- Joint sealing materials for pre-cast concrete culverts shall comply with the “AASHTO Designation M-198 74 I, Type B, Flexible Plastic Gasket (Bitumen)” specification.
- Two-sack-per-ton cement-stabilized sand shall be used for backfill around culverts.
- A six-inch bedding of two-sack-per-ton cement-stabilized sand is required for all pre-cast concrete box culverts.

### 5.1.6 Design Requirements for Bridges

Bridges shall be designed to meet the following requirements:

- Bridges shall be designed to convey the fully developed peak discharge rates associated with the design storm frequency requirements provided in Section 5.1.1 while maintaining a minimum freeboard of one-foot in the channel upstream of the bridge. In addition, the maximum allowable velocities discussed in Section 5.1.10 must not be exceeded.
- New bridges shall be designed to completely span the existing or proposed channel so that the channel will pass under the bridge without significant contractions or changes in the channel shape. Bridges constructed on existing or interim channels shall be designed to accommodate the ultimate channel section with minimum structural modifications.
- Bridges shall be designed to intersect the channel at an angle of 90 degrees, if possible.
- Pier bents and abutments shall be aligned parallel to the direction of flow in the channel. Pier bents shall be placed as far from the center of the channel as possible and wherever possible shall be placed within the channel side slopes instead of the channel bottom.
- Concrete slope paving or riprap shall be used to protect earthen channels from erosion underneath, upstream and downstream of bridges.
- Where hydraulic jumps are anticipated around bridges, the channel geometry shall be modified to force the hydraulic jump to occur in a portion of the channel protected with concrete slope paving.

### 5.1.7 Enclosed Drainage Systems

Enclosed drainage systems include pipe and box culverts used to replace segments of open channel longer than the typical width of a road or railroad ROW.

- Enclosed drainage systems shall be designed to accommodate fully developed design peak runoff rates discussed in Section 5.1.1 while maintaining the hydraulic grade line elevations below adjacent natural ground elevations or street gutter elevations, whichever are lower for fully-developed watershed conditions.
- The minimum inside pipe dimension shall be two feet.
- The minimum and maximum allowable velocities for design peak runoff rates shall be two feet per second and eight feet per second, respectively, assuming full pipe flow.
- Structural requirements for enclosed systems are identical to those specified for pipe and box culverts in Section 5.1.7.
- Manholes or junction boxes shall be located no more than 600 feet apart along the entire length of the system and at all locations where changes in culvert size and shape occur.
- Outfall structures shall conform to the requirements set forth for storm sewer outfalls in Chapter 7 of this manual.
- The ROW width required for enclosed systems will be set equal to the maximum pipe or box width plus two times the depth to the culvert invert or 30 feet, whichever is smaller.

### 5.1.8 Maximum Flow Velocities

The maximum allowable velocity in open channels and at bridges or culverts shall be analyzed for the design storm event. As shown in Table 5-2, the maximum allowable velocity is related to the type of channel, the slope treatment, and the soil structure throughout the open channel section. If the maximum velocities listed in this table are exceeded during the design storm event, then the channel design shall be modified until acceptable velocities are attained. Alternatively, erosion protection (i.e., riprap, concrete slope paving, or interlocking blocks) could be provided to increase the maximum allowable velocity in that portion of the channel (see Chapter 8). However, the erosion protection must extend upstream and downstream a sufficient distance to a location where the design storm velocity in the channel is below the maximum allowable levels for earthen channels without slope protection.

<b>TABLE 5-2: MAXIMUM ALLOWABLE VELOCITIES IN OPEN CHANNELS</b>		
<b>Soil Description</b>	<b>Slope Treatment</b>	<b>Maximum Velocity (feet per second)</b>
Fine Sand	None	1.50
Sandy Loam	None	1.75
Silt Loam	None	2.00
Clay Loam	None	2.50
Stiff Clay	None	3.75
Sandy Soils (Easily Eroded)	Grass	4.00
Clay Soils (Erosion-Resistant)	Grass	5.00
Sandy Soils (Easily Eroded)	Rip-Rap	6.00
Clay Soils (Erosion Resistant)	Rip-Rap	8.00
Sandy Soils (Easily Eroded)	Concrete	8.00
Clay Soils (Erosion Resistant)	Concrete	10.00
Bridges & Culverts		8.00

### 5.1.9 Maintenance

Provisions for adequate maintenance must be made in the design of all drainage facilities. Sufficient ROW must be set aside, slopes must be kept at or below maximum values, and slope treatments must be properly completed. Access to drainage facilities must not be impeded.

## 5.2 Hydraulic Analysis of Primary Drainage Facilities

This section describes the methods to be used in the hydraulic analysis of open channels as well as associated bridge and culvert structures.

### 5.2.1 Acceptable Open Channel Design Methodologies

The final open channel dimensions shall be determined by using the *HEC-RAS* computer program developed at the Hydrologic Engineering Center of the U.S. Army Corps of Engineers (USACE). The latest version of this software program can be downloaded from the USACE's website (<http://www.hec.usace.army.mil/software/hecras/hecras-download.html>) at no charge. The HEC-RAS program has the capability to analyze unsteady flow conditions, transitions from subcritical to supercritical flow, and other complex hydraulic conditions.

The hydraulic data discussed in Sections 5.2.1 to 5.2.8 should be compiled to facilitate development of HEC-RAS models. Additional information on HEC-RAS can be obtained from the *HEC-RAS River Analysis System User's Manual*, the *HEC-RAS River Analysis System Application's*

*Guide*, and the *HEC-RAS River Analysis System Hydraulic Reference Manual* developed by the USACE. All of these manuals can be downloaded free of cost from the USACE's website at <http://www.hec.usace.army.mil/software/hecras/hecras-document.html>.

### 5.2.2 Acceptable Bridge and Culvert Design Methodologies

Hydraulic analysis of bridges and culverts may be performed using the HEC-RAS computer program. However, the nomographs developed by the Federal Highway Administration (FHWA) published in *Hydraulic Design of Highway Culverts* may be used for initial estimates of culvert size or to verify that the results obtained from HEC-RAS are reasonable. These nomographs can also be used to size culverts associated with roadside ditches. In addition, any other software programs which meet industry standards can be used, if prior approval is obtained from the WCID #1.

### 5.2.3 Acceptable Enclosed Drainage System Design Methodologies

Hydraulic analysis of enclosed drainage systems that are part of an open channel system may be analyzed using HEC-RAS. In addition, any other software programs which meet industry standards can be used, if prior approval is obtained from the District. For stand-alone enclosed systems, the methodology described in Chapter 6 for storm sewer systems shall be used. For these calculations, full pipe flow may be assumed. Both friction losses and minor losses (i.e., losses due to transitions, bends, junctions, manholes, etc.) should be accounted for.

### 5.2.4 Flow Data

The Rational Method may be used to compute the peak flow rates for drainage areas up to 200 acres. However, a HEC-HMS hydrologic analysis can also be performed for drainage areas up to 200 acres. For drainage areas greater than 200 acres, the HEC-HMS methodology discussed in Chapter 4 shall be used to compute peak discharge rates for the design storm frequencies specified in Section 5.1.1. These peak flow rates shall be used to develop the flow data in HEC-RAS.

For an unsteady flow analysis, the inflow hydrographs computed in HEC-HMS are used instead of peak discharge rates. These hydrographs should be entered into the Unsteady Flow Data editor of HEC-RAS for unsteady flow detention analyses (see Chapter 7) or the applicable portion of other approved software programs.



### 5.2.5 Boundary Conditions

In order for HEC-RAS to perform computations, boundary conditions or starting WSELs must be defined. Boundary conditions are required at the downstream and upstream ends of the river system for subcritical and supercritical flow regimes, respectively. For mixed flow regimes, boundary conditions are required at both the upstream and downstream ends of the system. Subcritical flow typically occurs in the WCID #1 areas. This flow regime has a low velocity and appears tranquil, whereas the supercritical flow regime is characterized by shooting and rapid flows.

For unsteady flow detention analyses (see Chapter 7), a variety of boundary conditions are available within the Unsteady Flow Data editor. Refer to the *HEC-RAS River Analysis System User's Manual* for additional information on the available unsteady flow boundary conditions. For open channel analyses, the downstream boundary conditions should be entered into the Steady Flow Data editor. If a HEC-RAS model of the receiving channel is not available, then normal depth should be used as the downstream boundary condition and the energy slope should be entered. The energy slope can be approximated as the slope of the bottom of the channel. If a HEC-RAS model of the receiving channel is available and the tailwater in this channel can be determined, then the known WSEL downstream boundary condition should be selected.

In order to determine the tailwater *elevation* in the receiving channel, the Frequencies of Coincidental Occurrence methodology described in the Texas Department of Transportation's (TxDOT's) *Hydraulic Design Manual* shall be used. This methodology is based on the assumption that the rainfall events within the drainage system being analyzed and the receiving channel are neither completely dependent nor completely independent. As shown in Table 5-3, this method provides a basis for selecting an appropriate frequency for the tailwater elevation of the receiving channel versus the frequency for the tributary channel, storm sewer system, or *detention basin*. For example, a 100-year analysis of a tributary channel with a drainage area of 200 acres that discharges to an open channel with an associated drainage area of 2,000 acres would have a ratio of receiving channel to tributary of 10:1. Therefore, the required tailwater elevation for the 100-year analysis of the tributary channel would be the 50-year WSEL in the receiving channel.

<b>TABLE 5-3: FREQUENCIES OF COINCIDENTAL OCCURRENCE FOR DETERMINING TAILWATER ELEVATIONS IN RECEIVING CHANNELS</b>						
<b>Area Ratio</b>	<b>Design Storm Event for the Hydraulic Analysis of Tributary Channels, Storm Sewer Systems, or Detention Basins</b>					
	<b>2-year</b>	<b>5-year</b>	<b>10-year</b>	<b>25-year</b>	<b>50-year</b>	<b>100-year</b>
10,000:1	2	2	2	2	2	2
1,000:1	2	2	2	5	5	10
100:1	2	2	5	10	10	25
10:1	2	5	10	10	25	50
1:1	2	5	10	25	50	100

### 5.2.6 Cross-Section Data

The cross-section data required by HEC-RAS includes: elevation-station data; Manning's roughness coefficients ( $n$  values), which are described in Section 5.2.7; channel and overbank reach lengths; top of bank (TOB) locations; and expansion and contraction coefficients. If ineffective flow areas (IFAs), levees, or blocked obstructions exist, then geometric information regarding these items would also be entered in the Cross-Section Data Editor.

The elevation-station data shall be obtained from recent field survey data and the cross-sections shall be extended far enough into the left and right overbanks so that all of the flow is contained within the defined cross-section, if possible. Although LIDAR data may be used to supplement field survey data and define the overbank areas of the cross-sections, field survey data is required to accurately define the channel because LIDAR does not penetrate water. Cross-sections shall be taken approximately every 500 feet along the channel, unless project-specific considerations warrant otherwise. In the vicinity of bridges and culverts, cross-section spacing shall adhere to recommendations in the HEC-RAS program documentation referenced in Section 5.2.1. If necessary, additional cross-sections can be interpolated by HEC-RAS or field surveyed cross-sections can be copied to achieve the required cross-section spacing around bridges and culverts.

Channel reach lengths between cross-sections shall be measured along the centerline of the channel. As indicated in the *HEC-RAS River Analysis System Hydraulic Reference Manual*, left and right overbank lengths should be determined as the length along the anticipated path of the center of mass of overbank flow. In many instances, all three reach length values will be similar. However, they may differ significantly at channel bends and locations where the channel meanders while the overbanks remain straight.

For the WCID #1 area, the typical expansion and contraction coefficients for open channels are 0.1 and 0.3, respectively. However, higher coefficients of 0.3 and 0.5 should be used at cross-sections two, three, and four around bridges and culverts to simulate expansion and contraction conditions around these structures. Refer to the *HEC-RAS River Analysis System User's Manual* for information on the location of cross-sections two through four around bridges and culverts. IFAs should also be included around bridges and culverts using the recommendations outlined in the *HEC-RAS River Analysis System Hydraulic Reference Manual*.

HEC-GeoRAS can be used to automate the development of HEC-RAS models by importing channel geometric data directly into HEC-RAS. The channel centerline location, cross-section data, reach lengths, assumed TOB locations,  $n$  values, and expansion/contraction coefficients can be defined within HEC-GeoRAS and imported directly into HEC-RAS. However, this program requires input from an engineer or hydrologist experienced with hydraulic modeling. In addition, TOB locations and overbank reach lengths may need to be modified within HEC-RAS. IFAs, levees, and blocked obstructions would also need to be entered directly into HEC-RAS.

### 5.2.7 Manning's Roughness Coefficient

The HEC-RAS software program utilizes Manning's Equation, which is discussed in Chapter 3, to compute conveyance and flows in open channels. The  $n$  value used in this equation varies inversely with conveyance and is a measure of the roughness of the surfaces with which storm water comes into contact. For example, a forested area would have a higher  $n$  value and a lower conveyance than a pasture or open field. Recent aerial photographs as well as field reconnaissance can be used in conjunction with Table 5-4 to determine  $n$  values for channels and flood plains, or overbank areas.

Although Table 5-4 is generally adequate for selecting  $n$  values corresponding to existing field conditions, project-specific considerations may warrant the use of Equation 5-1 for a more detailed determination of  $n$  values associated with the channel and flood plains (overbanks). For most applications, it is acceptable to round  $n$  values to the nearest 0.005 (i.e., an  $n$  value of 0.033 would be entered into HEC-RAS as 0.035).

$$n = (n_0 + n_1 + n_2 + n_3 + n_4)m \quad \text{Equation 5-1}$$

- where:
- $n$  = composite Manning's roughness coefficient;
  - $n_0$  = base value for the bare soil surface material of the channel or flood plain;
  - $n_1$  = value to correct for the irregularity of the channel or flood plain;
  - $n_2$  = value to account for variations in the shape and size of the channel or flood plain cross-section;
  - $n_3$  = value to account for obstructions in the channel or flood plain;
  - $n_4$  = value to account for the effects of vegetation;
  - $m$  = correction factor for the sinuosity of the channel or flood plain.

Tables 5-5 and 5-6 provide a summary of parameters used in Equation 5-1 to compute  $n$  values for channels and flood plains, respectively.

<b>TABLE 5-4: MANNING'S ROUGHNESS COEFFICIENTS</b>			
<b>Type of Channel and Description</b>	<b>Minimum</b>	<b>Normal</b>	<b>Maximum</b>
<b>Excavated or Dredged Channels</b>			
<i>Concrete Lined Channels</i>	0.011	0.013	0.015
Earthen Channels, Straight and Uniform			
<i>Clean, After Weathering</i>	0.016	0.018	0.020
<i>With Short Grass, Few Weeds</i>	0.022	0.027	0.033
Earthen Channels, Winding and Sluggish			
<i>No Vegetation</i>	0.023	0.025	0.030
<i>Grass, Some Weeds</i>	0.025	0.030	0.033
<i>Dense Weeds or Plants in Deep Channels</i>	0.030	0.035	0.040
<i>Earth Bottom and Rubble Sides</i>	0.028	0.030	0.035
<i>Stony Bottom and Weedy Banks</i>	0.025	0.035	0.040
<i>Cobble Bottom and Clean Sides</i>	0.030	0.040	0.050
Channel Not Maintained, Weeds & Brush Uncut			
<i>Dense Weeds, High as Flow Depth</i>	0.050	0.080	0.120
<i>Clean Bottom, Brush on Sides</i>	0.040	0.050	0.080
<i>Same, Highest Stage of Flow</i>	0.045	0.070	0.110
<i>Dense Brush, High Stage</i>	0.080	0.100	0.140
<b>Natural Streams</b>			
Clean, Straight, Full Stage, No Rifts or Deep Pools	0.025	0.030	0.033
Same as Above, But Some Stones and Weeds	0.030	0.035	0.040
Clean, Winding, Some Pools and Shoals	0.033	0.040	0.045
Same as Above, But Some Weeds and Stones	0.035	0.045	0.050
Same as Above, Lower Stages, More Ineffective Areas	0.040	0.048	0.055
Sluggish Reaches, Weedy, Deep Pools	0.050	0.070	0.080
<b>Flood Plains</b>			
Pasture, No Brush			
<i>Short Grass</i>	0.025	0.030	0.035
<i>High Grass</i>	0.030	0.035	0.050
Cultivated Areas			
<i>No Crop</i>	0.020	0.030	0.040
<i>Mature Row Crops</i>	0.025	0.035	0.045
<i>Mature Field Crops</i>	0.030	0.040	0.050
Brush			
<i>Scattered Brush, Heavy Weeds</i>	0.035	0.050	0.070
<i>Light Brush and Trees, in Winter</i>	0.035	0.050	0.060
<i>Light Brush and Trees, in Summer</i>	0.040	0.060	0.080
<i>Medium to Dense Brush, in Winter</i>	0.045	0.070	0.110
<i>Medium to Dense Brush, in Summer</i>	0.070	0.100	0.160
Trees			
<i>Dense Willows, Summer, Straight</i>	0.110	0.150	0.200
<i>Cleared Land with Stumps, No Sprouts</i>	0.030	0.040	0.050
<i>Same as Above with Heavy Growth of Sprouts</i>	0.050	0.060	0.080
<i>Heavy Stand of Timber, a Few Down Trees, Little Undergrowth, Flood Stage Below Branches</i>	0.080	0.100	0.120
<i>Same as Above, but with Flood Stage Reaching Branches</i>	0.100	0.120	0.160

<b>TABLE 5-5: PARAMETERS USED IN COMPUTING CHANNEL ROUGHNESS COEFFICIENTS</b>		
<b>Parameter</b>	<b>Accounts For</b>	<b>Representative Roughness Values</b>
$n_0$	Channel Material	0.011 for Concrete 0.020 for Earth 0.025 for Rock Cut 0.024 for Fine Gravel 0.028 for Coarse Gravel
$n_1$	Degree of Irregularity	0.000 for Smooth 0.005 for Minor Irregularities 0.010 for Moderate Irregularities 0.020 for Severe Irregularities
$n_2$	Variation of Channel Cross-Section	0.000 for Gradual Variations 0.005 for Alternating Occasionally 0.010 to 0.015 for Alternating Frequently
$n_3$	Relative Effect of Obstructions	0.000 for Negligible Obstructions 0.010 to 0.015 for Minor Obstructions 0.020 to 0.030 for Appreciable Obstructions 0.040 to 0.060 for Severe Obstructions
$n_4$	Vegetation	0.005 to 0.010 for Low Vegetation 0.010 to 0.025 for Medium Vegetation 0.025 to 0.050 for High Vegetation 0.050 to 0.100 for Very High Vegetation
$m$	Degree of Meandering	1.000 for Minor Meandering 1.150 for Appreciable Meandering 1.300 for Severe Meandering

<b>Parameter</b>	<b>Accounts For</b>	<b>Representative Values</b>
$n_0$	Base Material	0.010 for Concrete 0.020 for Earth 0.025 for Rock Cut 0.024 for Fine Gravel 0.028 for Coarse Gravel
$n_1$	Degree of Irregularity	0.000 for Smooth 0.001 to 0.005 for Minor Irregularities 0.006 to 0.010 for Moderate Irregularities 0.011 to 0.020 for Severe Irregularities
$n_2$	Variation in Cross-Section	0.000 Not Applicable
$n_3$	Effect of Obstructions	0.000 to 0.004 for Negligible Obstructions 0.005 to 0.019 for Minor Obstructions 0.020 to 0.030 for Appreciable Obstructions
$n_4$	Amount of Vegetation	0.001 to 0.010 for Small Amounts 0.011 to 0.025 for Medium Amounts 0.026 to 0.050 for Large Amounts 0.051 to 0.100 for Very Large Amounts 0.100 to 0.200 for Extreme Amounts
$m$	Degree of Meander	1.00 Not Applicable

### 5.2.8 Bridge and Culvert Data

HEC-RAS requires the following data for bridge and culvert computations: deck/roadway data, geometric data for culverts, sloping abutments and pier data for bridges, and the bridge or culvert modeling approach. Detailed information on all of the HEC-RAS data entry requirements is included in the HEC-RAS program documentation listed in Section 5.2.1. The following data is required to define the deck/roadway within the Deck/Roadway Data Editor: the distance between the upstream side of the bridge/culvert and the cross-section immediately upstream of the structure; the width of the bridge deck/culvert; upstream and downstream bridge deck/culvert station-elevation data; a weir coefficient, which ranges from 2.6 for flow over a bridge deck to 3.0 for flow over elevated roadway approach embankments; upstream and downstream embankment side slopes; the maximum allowable submergence before the program switches to energy based calculations rather than pressure and weir flow; the minimum weir flow elevation; and the weir crest shape.

The following culvert geometric data is entered into the Culvert Data Editor of HEC-RAS: solution criteria, culvert shape and size, culvert chart and scale numbers, distance to upstream

cross-section, culvert length, entrance and exit loss coefficients, Manning's  $n$  values, upstream and downstream invert elevations, number of identical barrels, and centerline stations for each barrel. The highest upstream energy grade option should be selected for the culvert solution criteria. The Manning's  $n$  value and entrance loss coefficients for the culvert(s) should be determined from Tables 5-7 and 5-8, respectively, and entered into the Culvert Data Editor. Typical exit loss coefficients for culverts range from 0.3 to 1.0, but are normally set at 1.0. Additional information on exit loss coefficients can be found in the *HEC-RAS River Analysis System Hydraulic Reference Manual*. A summary of the chart and scale numbers used by HEC-RAS for the FHWA culvert performance nomographs described in Section 5.2.2 is provided in Table 5-9. These FHWA nomographs are used as the basis for inlet control headwater computations in HEC-RAS. Field survey data and construction drawings should be used to determine the remaining culvert geometric data required by HEC-RAS.

<b>TABLE 5-7: MANNING'S ROUGHNESS COEFFICIENTS FOR CULVERTS</b>	
<b>Description of Pipe</b>	<b>Roughness Coefficient (<math>n</math>)</b>
Reinforced Concrete Pipe and Box Culverts	0.013
HDPE Plastic Pipe	0.012
Corrugated Steel Pipe With 2-2/3" x 1/2" Corrugations	0.024
Corrugated Steel Pipe With 3" x 1" Corrugations	0.027
Corrugated Steel Pipe With 6" x 2" Corrugations	0.030



<b>TABLE 5-8: ENTRANCE LOSS COEFFICIENTS FOR CULVERTS</b>	
<b>Type of Structure and Configuration of Entrance</b>	<b>Coefficient (<math>K_e</math>)</b>
<i>Concrete Pipe Culverts</i>	
Projecting from Fill	
Socket End (Groove End) of Pipe	0.2
Square-Cut End of Pipe	0.5
Headwall or Headwall & Wingwalls	
Socket End of Pipe (Groove End)	0.2
Square Edge	0.5
Mitered to Conform to Fill Slope	0.7
End Section Conforming to Fill Slope	0.5
<i>Corrugated Steel Culverts</i>	
Projecting From Fill	0.9
Headwall or Headwall & Wingwalls	0.5
Mitered to Conform to Fill Slope	0.2
End Section Conforming to Fill Slope	0.5
<i>Concrete Box Culverts</i>	
Headwall Parallel to Embankment (No Wingwalls)	0.5
Wingwalls at 30 Degrees to 75 Degrees to Barrel	0.4
Wingwalls at 10 Degrees to 25 Degrees to Barrel	0.5
Wingwalls Parallel (Extensions of Sides)	0.7

<b>TABLE 5-9: FHWA CHART AND SCALE NUMBERS FOR CULVERTS</b>		
<b>Chart No.</b>	<b>Scale No.</b>	<b>Description of Culvert and Entrance Configuration</b>
<i>Box Culverts with Flared Wingwalls</i>		
8	1	Wingwalls Flared 30 to 75 Degrees
	2	Wingwalls Flared 90 or 15 Degrees
	3	Wingwalls Flared 0 Degrees (Sides Extended Straight)
<i>Concrete Pipe Culverts</i>		
1	1	Square Edge Entrance with Headwall
	2	Groove End Entrance with Headwall
	3	Groove End Entrance, Pipe Projecting from Fill
<i>Corrugated Steel Culverts</i>		
2	1	Headwall
	2	Mitered to Conform to Fill Slope
	3	Pipe Projecting from Fill

Sloping abutment and pier data for bridges can be entered into the Sloping Abutment Data Editor and Pier Data Editor, respectively. The sloping abutment data requirements consist of station-elevation data, while the pier data requirements consist of elevation-width data as well as upstream and downstream centerline stations. The floating debris around a pier or piers can also be entered into the Pier Data Editor. In addition, the Bridge Design Editor within HEC-RAS can be used to facilitate the design of new bridges.

The Bridge Modeling Approach Editor requires the selection of low flow and high flow (pressure and/or weir) computation methods. Low flow occurs when water passes under a bridge or through a culvert without submerging the low chord of the bridge structure or the top of the culvert. Pressure flow occurs whenever the low chord of the bridge or the entire culvert is submerged and weir flow occurs when water overtops the roadway. Available low flow methods include: Energy (Standard Step), Momentum, Yarnell, and WSPRO. The Energy method should be selected for culvert analyses. Although a single low flow method may be selected for bridges, it is recommended that the Energy method as well as one or more other applicable methods be selected and that the highest energy answer be used. If the Momentum or Yarnell methods are selected for bridges, the user must enter a value for the pier loss coefficient that corresponds to that method. A list of representative coefficients can be obtained within the Bridge Modeling Approach Editor. If the WSPRO method is selected, the user must press the WSPRO Variables button and enter additional information that is required for that method. The available high flow methods are Energy (Standard Step) and Pressure and/or Weir. It is recommended that both of these methods be selected and that the highest energy answer be used.

### 5.2.9 Floodway Analysis

A floodway analysis is required if modifications are made to HEC-RAS models of streams that were studied by the Federal Emergency Management Agency (FEMA). As described in Chapter 5 and illustrated on Exhibit 5-4, the floodway is a corridor of effective flow that includes the channel and any adjacent land areas required to pass the 100-year peak discharge rates without increasing the WSEL at any point along the channel more than one-foot above the 100-year base flood elevations (BFE). The floodway is a regulatory concept that is intended to prevent encroachments (i.e., fill, structures, or other obstructions) from being placed too close to the channel without extensive analysis and mitigation measures. Additional information on FEMA requirements for floodway analysis can be obtained from FEMA's website (<http://www.fema.gov>), the HEC-RAS program documentation.

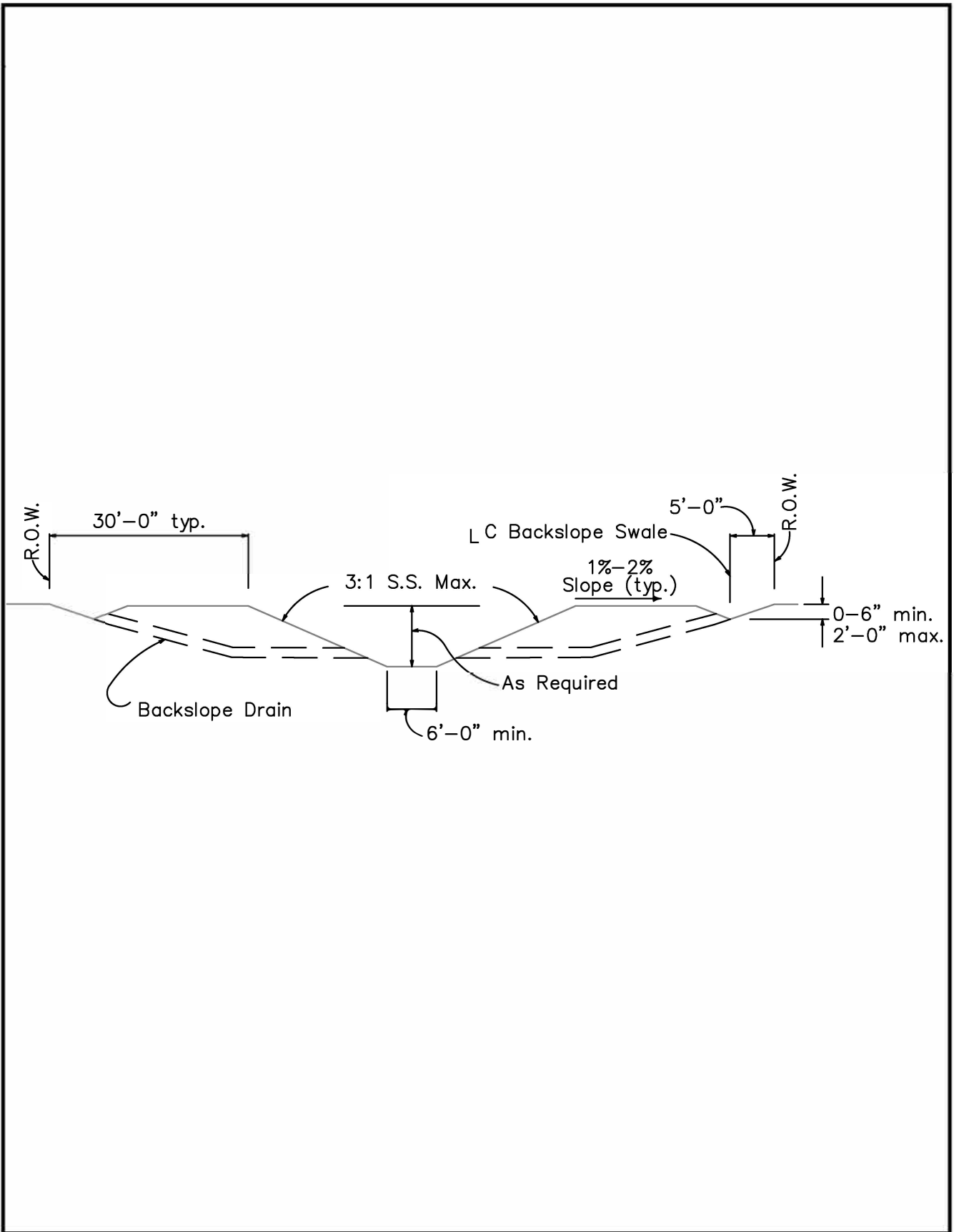

LIBERTY COUNTY WATER  
CONTROL IMPROVEMENT  
DISTRICT #1

TYPICAL SECTION  
GRASS-LINED TRAPEZOIDAL CHANNEL

DATE AUGUST 2016

EXHIBIT NO. 5-1

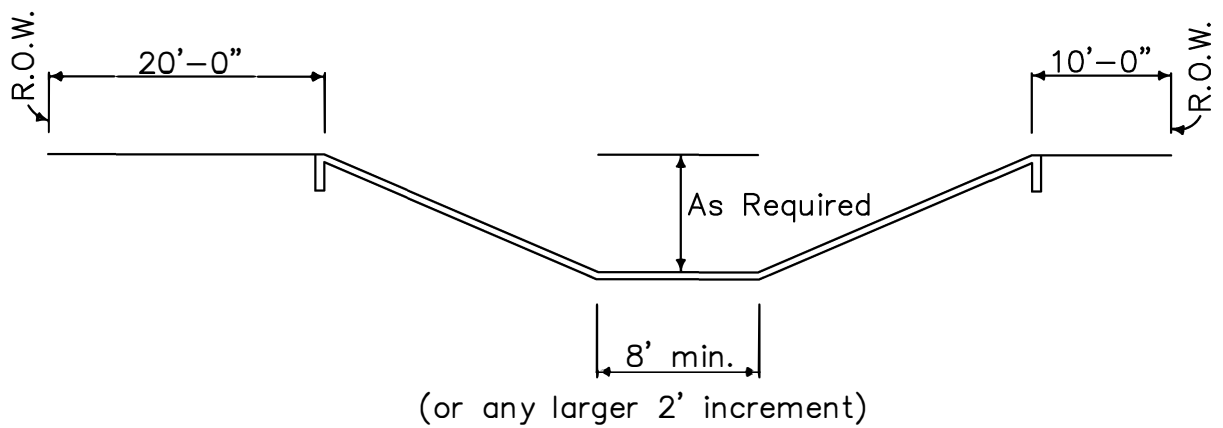

LIBERTY COUNTY WATER  
 CONTROL IMPROVEMENT  
 DISTRICT #1

TYPICAL SECTION  
 CONCRETE-LINED TRAPEZOIDAL CHANNEL

DATE AUGUST 2016

EXHIBIT NO. 5-2

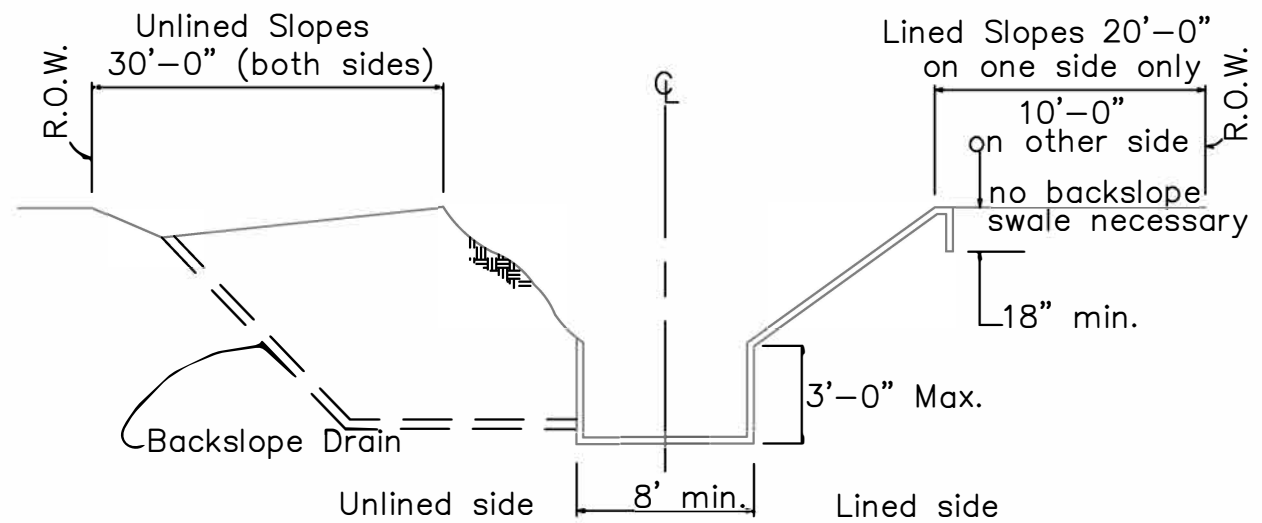

LIBERTY COUNTY WATER  
CONTROL IMPROVEMENT  
DISTRICT #1

TYPICAL CROSS-SECTION, CONCRETE-LINED  
WITH RECTANGULAR LOW-FLOW SECTION

DATE AUGUST 2016

EXHIBIT NO. 5-3

## 6 DETENTION ANALYSIS

The purpose of this chapter is to provide criteria and guidelines to be used in the analysis of detention facilities. Detention facilities are intended to mitigate increases in peak flows and changes in the timing of runoff associated with urbanization so that surrounding properties and the receiving body of water are not adversely impacted by increases in peak flows or water surface elevations (WSELs). Refer to Chapter 3 for additional information on the effects of urbanization.

It is important to note that detention will be required for the following types of improvements: new development; redevelopment; roadway expansion; drainage system improvements; and any other improvements that increase the impervious cover, decrease the time of concentration ( $T_C$ ), or increase the peak flows from a drainage area. Additional information on impervious cover,  $T_C$  values, and peak flows is provided in Chapter 4.

The civil engineering industry's standard of care for detention analysis is the 100-year event, which is typically used by public entities requiring detention. In addition, the 100-year rainfall event is used by the Federal Emergency Management Agency (FEMA) to define the level of flooding risk within communities that participate in the National Flood Insurance Program (NFIP). Therefore, the 100-year design storm event will be used as the basis for detention analysis in WCID #1. In some instances, five-year and 25-year design storm events will also need to be analyzed to ensure that the proposed detention facility does not cause adverse impacts during more frequent rainfall events.

### 6.1 General Design Requirements

The following design requirements are discussed in this section: design storm frequencies, detention basin location and geometry, maintenance berms, maintenance, pumped detention facilities, multi-purpose design, and extreme event overflow structures.

#### 6.1.1 Design Storm Frequencies

The following design storm frequencies should be used for detention analysis and design.

- The required storage volume for detention basins serving up to 200 acres (that are analyzed using the simplified methodology described in Section 6.3) shall be designed for a 100-year design storm event.
- Detention basins serving drainage areas greater than 200 acres and areas up to 200 acres that are analyzed using the methodology described in Section 6.4 shall be analyzed for the 10- and 100-year design storm events.

## 6.1.2 Detention Basin Location and Geometry

In order to facilitate pavement and storm sewer drainage, detention basins should typically be located in the lowest portion of the drainage area contributing to the basin. In addition, detention basins should be located immediately adjacent to the receiving drainage system where feasible. This will minimize the required length of outfall pipe and decrease maintenance strip requirements (see Section 6.1.3), which may decrease overall drainage system costs. The basic geometry of a typical detention basin is illustrated on Exhibits 6-1 and 6-2. The following criteria shall be used in detention basin design:

- Side slopes of detention basins shall be no steeper than three horizontal to one vertical (3:1). However, the use of these side slopes should be verified by a geotechnical report. If soil conditions are conducive to slope instability, flatter side slopes may be required.
- A minimum transverse slope of 0.50-percent shall be used on the bottom of the detention basin.
- A minimum of one-foot of freeboard shall be provided in the detention basin.
- A six-foot wide concrete pilot channel with a depth of four inches shall be provided in the bottom of the basin to facilitate drainage and avoid erosion problems. A minimum slope of 0.10-percent shall be used for concrete pilot channels.
- Earthen pilot channels with a minimum depth of two feet may be substituted for concrete pilot channels for aesthetic reasons or to facilitate multi-purpose use of a detention facility. The minimum slope for earthen pilot channels is 0.20-percent and the side slopes of earthen pilot channels shall be no steeper than three horizontal to one vertical (3:1).
- The minimum allowable outfall pipe size is 18 inches. If the detention analysis shows that a smaller pipe is required to restrict discharges, then a restrictor shall be placed inside an 18-inch diameter pipe.
- The use of parking lot detention storage is acceptable provided that the maximum ponding depth does not exceed six inches. However, it is recommended that preliminary approval be obtained from WCID #1 Staff prior to beginning a detailed design of any parking lot detention facility.

### 6.1.3 Maintenance Berms

For detention basins proposed to be maintained by the WCID #1, a minimum 30-foot maintenance strip shall be provided around the entire detention basin. Detention basins located immediately adjacent to a drainage channel with a dedicated right-of-way (ROW) and a maintenance strip wide enough to satisfy channel design criteria may share the adjacent channel maintenance strip. However, the combined total width of the channel and detention basin maintenance strips shall not be less than 30 feet under any circumstances.

For detention basins proposed to be maintained privately, a minimum 20-foot maintenance strip shall be provided around the entire detention basin. Detention basins located adjacent to parking lots may satisfy ten feet of the maintenance strip requirement with the paved parking area. However, adequate access for maintenance equipment must be provided.

### 6.1.4 Maintenance

All detention facilities shall be located in readily accessible areas and two access routes should be provided where possible. The following maintenance activities should be performed on a regular basis: mowing, slope repairs, removal of accumulated sediments, and repairs to discharge structures. In addition, a maintenance schedule should be prepared in conjunction with the detention design and periodically updated by the agency or entity responsible for maintenance of the detention facility. WCID #1 will not be responsible for the maintenance of detention facilities designed to mitigate the development of individual private projects or the construction of infrastructure improvements projects intended to serve private developments.

### 6.1.5 Pumped Detention Facilities

Detention facilities which rely on pumps to discharge all or part of the storm water which flows into them are generally not recommended. For facilities where pumps are required, the pump facilities should possess sufficient discharge capacity to accommodate the design 100-year peak discharge rate with the largest pump out of service. However, these facilities will require approval by the District.

### 6.1.6 Multi-Purpose Design

WCID #1 encourages multi-purpose features in detention facilities provided that the storm water management function of the facility is not compromised. In addition, the multi-purpose detention facilities must be designed to accommodate the maintenance activities



discussed in Section 6.1.4 and to provide safety features. Recommended multi-purpose features include permanent ponds, wetlands, playgrounds, soccer fields, and hiking or biking trails.

### 6.1.7 Extreme Event Overflow Structures

All detention basins shall be designed so that storm water runoff in excess of the 100-year rainfall event is conveyed to the nearest drainage channel without flooding structures. Overflow depths up to one-foot above basin top of bank elevations should be considered. Grass-lined earthen swales, weirs, concrete-lined overflow sections, and other structures may be utilized to convey these overflows.

## 6.2 Peak Discharge Rates

The following items related to peak discharge rates are discussed in this section: methodology, allowable peak discharge rates, and off-site flows.

### 6.2.1 Methodology

As described in Chapter 4, the Rational Method may be used for drainage areas up to 200 acres, and HEC-HMS shall be used for drainage areas greater than 200 acres to determine peak discharge rates consistent with the aforementioned criteria. For drainage areas greater than 200 acres or for smaller drainage areas being analyzed with the detention routing methodology described in Section 7.4, inflow hydrographs shall be computed by HEC-HMS.

### 6.2.2 Allowable Peak Discharge Rates

- For detention facilities serving drainage areas up to 200 acres, the maximum allowable peak discharge rate shall be limited to the existing conditions 10- and 100-year peak discharge rates for the 10- and 100-year design storm events, respectively.
- For detention basins with drainage areas greater than 200 acres, the peak discharge shall also be restricted to the existing conditions 10- and 100-year peak discharge rates for the 10- and 100-year design storm events, respectively.

It is important to note that limiting discharges during the two rainfall events may require multiple outfall structures (i.e., a low-flow pipe with a larger diameter pipe or weir stacked above).

### 6.2.3 Off-Site Flows

An investigation of off-site flows shall be completed as part of every drainage study or detention analysis. Off-site flows that drain through a project must be accommodated by the proposed

drainage plan. When off-site (run-on) flows are routed through a detention basin, the allowable peak discharge rates shall be based on the entire contributing (project and off-site) drainage area. For this case, regardless of acreage, the detailed detention analysis methodology described in Section 6.4 must be used.

A downstream off-site drainage facility may be required to convey the storm water from the project site to the receiving system, with sufficient 100-year capacity based upon contributing upstream acreage under existing conditions. This offsite drainage facility shall have sufficient drainage easement for conveyance and maintenance purposes. For the width of the ROW required for channels, see Section 5.1.2 for earthen channels and Section 5.1.3 for concrete-lined channels. For enclosed systems, the minimum ROW width is equal to the widest dimension of the underground conduit plus two times the maximum depth from finished ground to the invert of the conduit, or 30 feet, whichever is greatest.

## 6.3 Detention Analysis for Drainage Areas up to 200 Acres

This section describes the methodology to be used in determining the required detention storage volume and outfall structure size for drainage areas up to 200 acres.

### 6.3.1 Detention Analysis for Drainage Areas Up to 200 Acres

The simplified detention analysis methodology developed for drainage areas up to 200 acres is based on the triangular hydrograph method. Equations 6-1 through 6-3 can be used to compute the required detention storage volume as the area between triangular inflow and outflow hydrographs for the basin (Exhibit 6-3). In this method, the outflow hydrograph is assumed to intersect the receding limb of the inflow hydrograph at a flow rate equal to the maximum allowable peak discharge rate from the detention facility. Equation 6-1 can be used to calculate the time base of the triangular inflow hydrograph (B):

$$B = \frac{43,560V_R}{0.5Q_I} \quad \text{Equation 6-1}$$

where:  $B$  = time base of the triangular inflow hydrograph (seconds);  
 $V_R$  = the detention inflow volume in (acre-feet);  
 $Q_I$  = the proposed 100-year peak inflow rate (cubic feet per second).

The detention inflow volume ( $V_R$ ) can be computed using Equation 6-2:

$$V_R = A(XS) \quad \text{Equation 6-2}$$

where:  $A$  = drainage area served by detention basin (acres);

$XS$  = rainfall excess, from Table 6-1 (feet).

The rainfall excess shall be determined from Table 6-1 based on the soil type and proposed impervious cover of the drainage area. If the proposed impervious cover falls between the values listed in this table, then the rainfall excess should be estimated by interpolation.

% Impervious Cover	Rainfall Excess by Soil Groups (feet)			
	A	B	C	D
0	0.03	0.43	0.81	0.95
10	0.14	0.51	0.85	0.98
20	0.26	0.58	0.89	1.00
30	0.37	0.66	0.92	1.02
40	0.49	0.73	0.96	1.04
50	0.61	0.81	1.00	1.07
60	0.72	0.88	1.04	1.09
70	0.84	0.96	1.07	1.11
80	0.95	1.03	1.11	1.14
90	1.07	1.11	1.15	1.16
100	1.18	1.18	1.18	1.18

Equation 6-3 can be used to estimate the detention storage requirement ( $V_S$ ) for drainage areas up to 200 acres.

$$V_S = \frac{0.5B(Q_I - Q_O)}{43,560} \quad \text{Equation 6-3}$$

where:  $V_S$  = detention storage requirement (acre-feet);

$Q_O$  = maximum allowable peak discharge rate (cubic feet per second).

### 6.3.2 Design of Outfall Structures for Drainage Areas up to 200 Acres

Detention outfall structures shall be designed to limit discharges to the allowable peak discharge rates described in Section 6.2.2. If requested by the District or if tailwater conditions in the

receiving system warrant, the detention routing analysis and outfall structure sizing described in Section 6.4 shall be used. Otherwise, the required outfall pipe diameter for drainage areas up to 200 acres can be estimated by trial and error calculations using the procedure described in this section. Equation 6-4 is an acceptable head loss equation for pipe culverts flowing full that can be used to solve for pipe diameter:

$$H_T = \left[ \frac{2.52(1 + K_e)}{D^4} + \frac{466n^2L}{D^{16/3}} \right] \frac{Q^2}{100} \quad \text{Equation 6-4}$$

where:  $H_T$  = available head (feet);  
 $K_e$  = entrance loss coefficient, typically 0.5;  
 $D$  = diameter of pipe (feet);  
 $n$  = Manning's roughness coefficient, from Table 7-4;  
 $L$  = length of culvert (feet);  
 $Q$  = design discharge rate (cubic feet per second).

If a HEC-RAS model of the receiving channel exists, then the Frequencies of Coincidental Occurrence methodology described in Chapter 6 shall be used to determine the constant tailwater in the receiving channel and to calculate the available head ( $H_T$ ) for the 100-year analysis using Equation 7-5. Otherwise, an  $H_T$  of two feet can be assumed for the 100-year design storm event. In addition, an  $H_T$  of two feet should be used for the 10-year design storm event.

$$H_T = h_{basin} - h_{channel} \quad \text{Equation 6-5}$$

where:  $H_T$  = available head (feet);  
 $h_{basin}$  = 100-year design WSEL in detention basin (feet);  
 $h_{channel}$  = tailwater elevation in channel from Frequencies of Coincidental Occurrence (feet).

Once a pipe diameter is selected, Equation 6-6 shall be used to calculate the design peak discharge rate for the design storm event specified in Section 6.2.1 to ensure that the maximum allowable discharge rate is not exceeded.

$$Q = \sqrt{\frac{100H_T}{\frac{2.52(1 + K_e)}{D^4} + \frac{466n^2L}{D^{16/3}}}} \quad \text{Equation 6-6}$$

If the HEC-HMS detention routing methodology described in Section 6.4 is used to analyze a detention basin with a drainage area less than or equal to 200 acres, then the outfall structure shall also be sized using the methodology for drainage areas greater than 200 acres.

## 6.4 Detention Analysis for Drainage Areas Greater than 200 Acres

A detailed detention routing analysis is required for detention basins serving drainage areas greater than 200 acres. As indicated previously, this method may also be used for drainage areas less than 200 acres. Detention routing shall be performed for the 10- and 100-year rainfall events and the allowable peak discharge rates shall be determined from Section 6.2.2. Sections 6.4.1 through 6.4.4 discuss the hydrologic and hydraulic data required to develop detention routing models.

### 6.4.1 Acceptable Detention Routing Software Programs

The detention routing may be performed in HEC-HMS, HEC-RAS unsteady flow, Storm Water Management Model (SWMM), a detention routing spreadsheet, or other generally accepted detention basin routing programs approved by the District. The HEC-HMS and HEC-RAS manuals referenced in Chapters 4 and 5 should be consulted for additional information regarding the detention routing capabilities of these programs.

### 6.4.2 Inflow Hydrographs

Proposed conditions inflow hydrographs for the various design storm events should be developed in HEC-HMS using the hydrologic criteria presented in Chapter 4.

### 6.4.3 Stage-Storage Relationship

A stage-storage or stage-area relationship should be developed from the detention basin grading plan and entered into the detention routing model.

### 6.4.4 Outfall Structure

Detention outfall structures shall be designed to limit discharges to the allowable peak discharge rates described in Section 6.2. Depending on the detention routing software program, the outfall structure will either be input directly into the model or simulated with a stage-discharge relationship calculated independently and entered into the model. For HEC-HMS, the outfall structure is described using a stage-discharge relationship. For HEC-RAS unsteady flow or other unsteady flow models, the size and material of the outfall structure along with tailwater conditions within the receiving channel are entered into the model and a stage-discharge

relationship is computed automatically. In either case, the required size of the outfall structure is dependent on tailwater conditions within the receiving channel.

A constant tailwater elevation in the receiving channel shall be estimated using the Frequencies of Coincidental Occurrence methodology described in Chapter 5. This constant tailwater elevation can be used to develop a stage-discharge relationship for an outfall structure of a specific diameter using Equation 6-6 or other hydraulic modeling program. The calculated stage-discharge relationship can then be incorporated into HEC-HMS or another acceptable model. In areas where tailwater conditions are a concern (i.e., detention basins located in 100-year flood plains, channels where WSELs remain high for long periods, channels with steeply rising WSELs, and areas with existing flooding problems), a stage hydrograph (elevation versus time) shall be developed for the receiving channel and used in a HEC-RAS unsteady flow model or other acceptable software that allows stage hydrographs as a downstream boundary condition.

As indicated in Section 6.2.7, an extreme event overflow structure must be provided in all detention basins to accommodate storm water runoff in excess of the 100-year event without flooding structures. Standard hydraulic methods shall be used to determine the required dimensions of the overflow structure.

#### 6.4.5 Acceptable Results

Once preliminary detention routing results are obtained, the peak discharge rate from the proposed detention basin shall be compared to the allowable peak discharge rate for each design storm event being analyzed (see Section 6.2.2). If the peak discharge rate for any of the design storm events exceeds the allowable peak discharge rate for that event, the size and/or configuration of the outfall structure shall be adjusted until acceptable results are obtained. In addition, the detention basin grading plan may also need to be revised to ensure that adequate volume is provided to maintain one-foot of freeboard in the basin. If the grading plan is revised, an updated stage-storage relationship will need to be developed and incorporated in the detention routing model.

### 6.5 Downstream Impacts

For drainage areas greater than 640 acres or if requested by the District for smaller drainage areas, a HEC-HMS downstream impacts analysis shall be performed to demonstrate that the proposed detention facility does not cause any impacts (increases in peak flows) downstream of the detention facility. If prior approval is obtained from the District, other standard software may be used for the downstream impacts analysis. The District has the option to request a downstream impacts

analysis for drainage areas located in the lower half of their respective watershed. If a downstream impacts analysis is requested for drainage areas up to 200 acres, then the hydrologic methodology for drainage areas over 200 acres (see Chapter 4) and the detention routing method for drainage areas over 200 acres (Section 6.4) shall be used. The downstream impacts analysis shall be performed for the 10- and 100-year rainfall events. At a minimum, the downstream impacts analysis shall compare peak discharges downstream of the site to the mouth of the receiving channel. However, WCID #1 staff has the option to request that the downstream impacts analysis be continued further downstream.

The routed outflow hydrograph from the detention basin should be incorporated into a detention conditions HEC-HMS model of the receiving channel. The resulting peak discharge rates downstream of the proposed detention shall be compared to the existing conditions peak discharges rates prior to development of the project site. If the drainage area served by the proposed detention basin is part of a larger drainage area, then the larger area should be subdivided to create revised existing and detention conditions models where the area served by the detention basin is represented by a stand-alone sub-basin. If the analysis indicates that there are increases in peak flows downstream of the proposed detention facility, then the discharge structure and/or detention basin shall be modified to eliminate these increases.

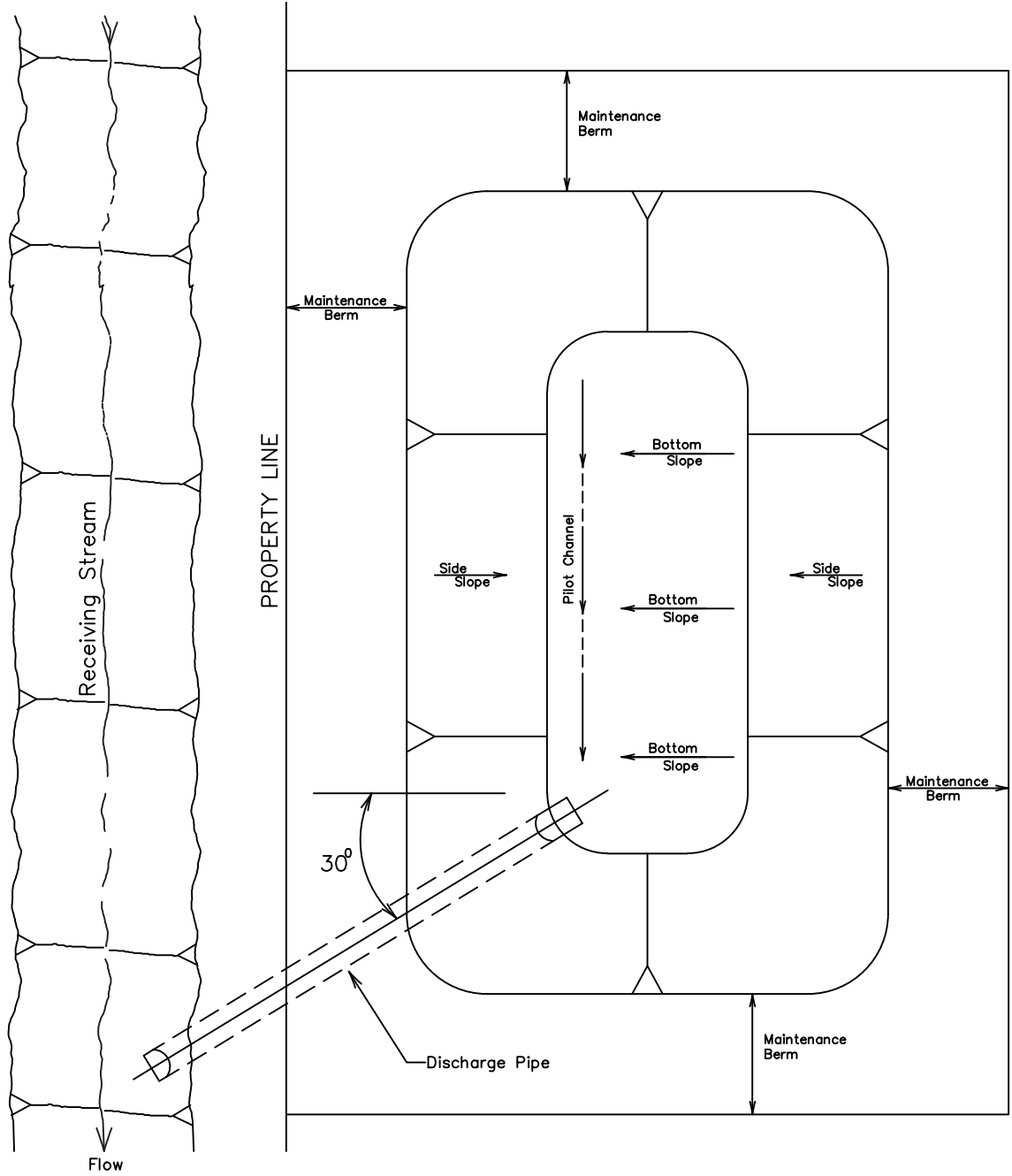

LIBERTY COUNTY WATER  
CONTROL IMPROVEMENT  
DISTRICT # 1

TYPICAL DETENTION BASIN LAYOUT

DATE AUGUST 2016

EXHIBIT NO. 6-1



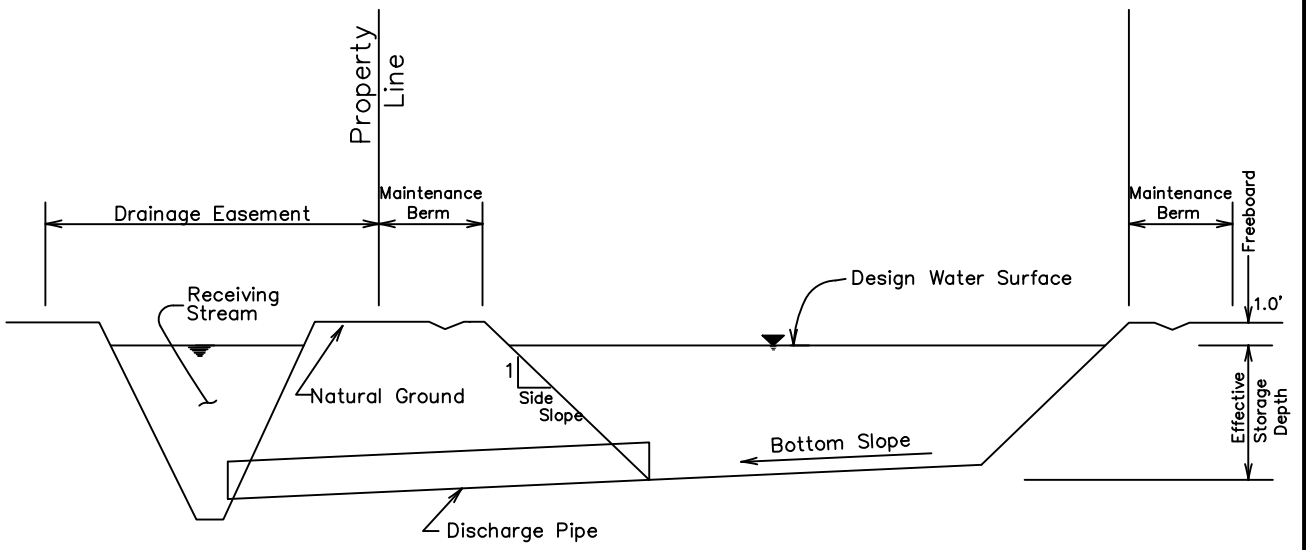

LIBERTY COUNTY WATER  
CONTROL IMPROVEMENT  
DISTRICT # 1

TYPICAL DETENTION BASIN  
CROSS-SECTION

DATE AUGUST 2016

EXHIBIT NO. 6-2

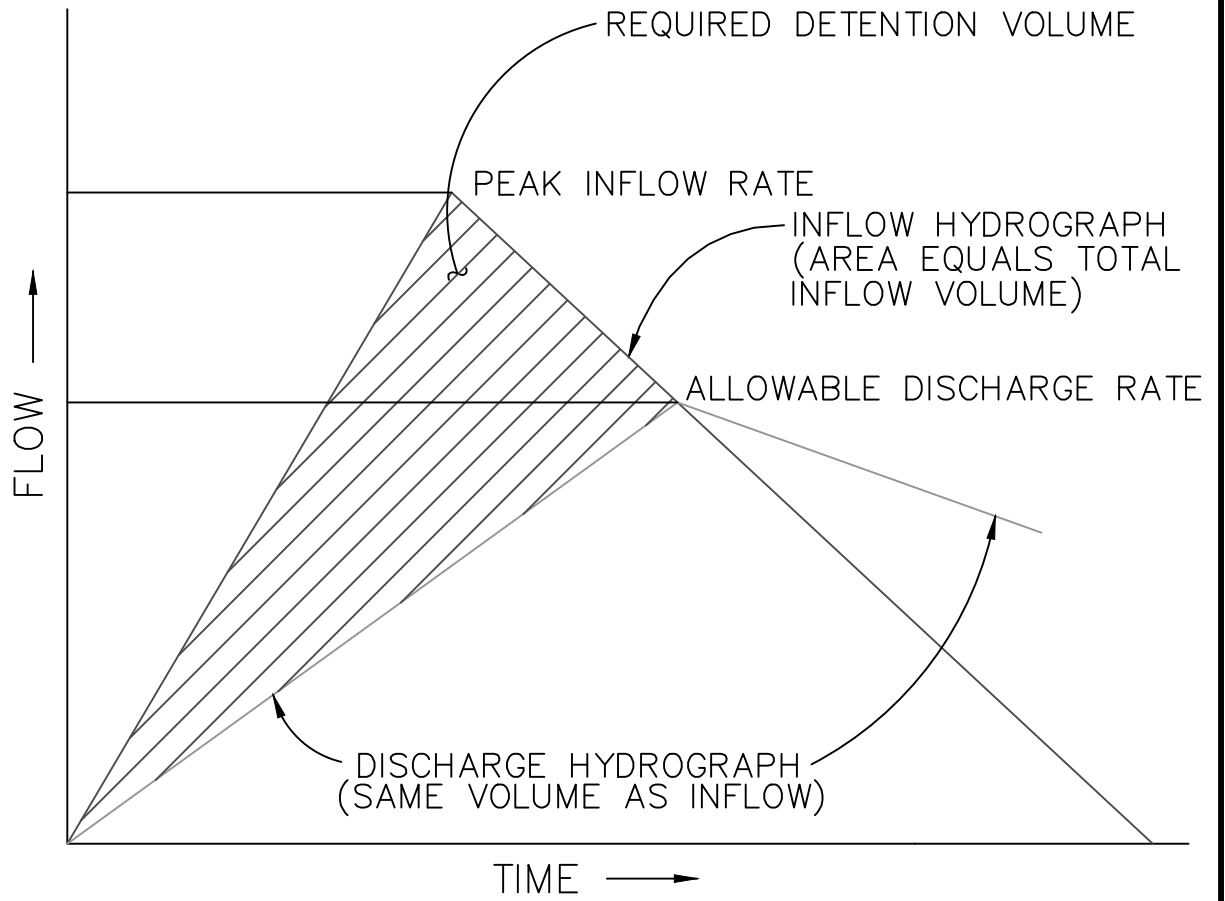

LIBERTY COUNTY WATER  
 CONTROL IMPROVEMENT  
 DISTRICT # 1

DETENTION STORAGE  
 VOLUME FOR DRAINAGE AREAS  
 UP TO 200 ACRES

DATE AUGUST 2016

EXHIBIT NO. 6-3

## 7 EROSION AND SEDIMENT CONTROL

This section of the manual describes methods for controlling erosion and sediment deposition in drainage facilities in WCID #1.

### 7.1 Effects of Erosion and Sedimentation

Erosion and sedimentation can have very serious effects on storm water drainage. Some of these effects are summarized below:

- **Integrity of Drainage Facilities:** Erosion can cause slope failures, increase roughness coefficients, and generally reduce the efficiency of drainage channels. However, sediment deposition can clog drainage culverts and reduce the available conveyance in open channels.
- **Maintenance:** Erosion can significantly reduce the maintainability of drainage facilities and increase the cost of maintenance by increasing the frequency with which repairs are required.
- **Water Quality:** Erosion and sedimentation can increase the turbidity of water and may cause other water quality problems associated with pollutants attached to soil particles.

### 7.2 Areas with High Erosion Potential

Areas with relatively high erosion potential include the following:

In channel bends, especially where the radius of curvature is less than three times the top width of flow in the channel.

- Around bridges and culverts where channel transitions and reduced flow areas create increased flow velocities.
- In steep sections of channels and ditches and on steep, unprotected slopes where flow velocities may reach erosive levels.
- Along grass-lined channel side slopes where significant amount of storm water runoff flows over the channel bank and down the sides of the channel.
- At confluences where flows in tributary channels, storm sewers, or roadside ditches enter a receiving channel.
- In areas where non-cohesive soils are particularly prone to erosion.

## 7.3 Slope Protection Methods

The following sections describe some of the most common slope protection methods.

### 7.3.1 Turf Establishment

The establishment of grass on exposed earthen side slopes is the most common method for protecting the slopes from erosion. Grass establishment should be initiated as quickly as possible after channel construction or repair work is completed. The grasses used for this purpose should be of hardy varieties which do not require repeated watering and excessive amounts of care once they are established. Grasses with deep root systems are preferable to those with shallower root systems because they are more resistant to drought.

### 7.3.2 Slope Paving

Concrete slope paving is an effective slope protection method, but is too expensive to apply over large areas. Therefore, slope paving is most commonly used in limited areas where the potential for erosion is very high. Table 7-1 provides a summary of slope paving requirements for varying channel side slopes.

Channel Side Slope (H:V)	Minimum Thickness (inches)	Minimum Reinforcement	
		Material	Dimensions
3:1	4 inches	welded wire fabric	6 x 6 x W2.9 x W2.9
2:1	5 inches	welded wire fabric	6 x 6 x W4.0 x W4.0
1.5:1	6 inches	reinforcement	4 x 4 x W4.0 x W4.0

Minimum requirements for concrete slope paving are as follows.

- All concrete slope paving shall consist of Class A concrete.
- The side slopes of the channel shall be no steeper than 1.5 horizontal to 1 vertical (1.5:1).
- All slope paving shall include a toe wall at the top and sides with a minimum depth of 18 inches. Toe walls shall also be included along the bottom of the channel with a minimum depth of 24 inches for clay soils and 36 inches for sandy soils.

Weep holes shall be used to relieve hydrostatic pressure behind lined channel sections. The specific type, size, and placement of the weep holes shall be based on the recommendations of the geotechnical report.

- Where construction is to take place under muddy conditions or where standing water is present, a seal slab of Class C concrete shall be placed in the channel bottom prior to placement of the concrete slope paving.
- Control joints shall be provided at a maximum spacing of 25 feet. A sealing agent shall be utilized to prevent moisture infiltration at control joints.

### 7.3.3 Rip-Rap

Rip-rap consists of rock or broken concrete pieces with a minimum dimension of about six inches and a maximum dimension of 18 to 24 inches. Rip-rap is normally hand-placed as a layer which extends 18 inches below the finished channel grade. Minimum requirements for rip-rap are as follows.

- The minimum mat thickness shall be 18 inches.
- Well-graded blocks weighing from 40 pounds to 265 pounds shall be used.
- The maximum steepness of slopes protected by rip-rap shall be 2 horizontal to 1 vertical.
- Filter fabric bedding is required in areas where rip-rap is placed on sandy or silty soils. On cohesive clay soils with very little sand content (less than 20-percent sand), filter fabric is not required.

Sacks of ready-mix concrete may not be used as rip-rap because lack of gradation allows water penetration and undermining of the soil under the installation.

### 7.3.4 Acceptable Velocities for Various Slope Treatments

The maximum allowable velocity in open channels and at bridges or culverts shall be analyzed for the design storm event. As shown in Table 7-2, the maximum allowable velocity is related to the type of channel, the slope treatment, and the soil structure throughout the open channel section. If the maximum velocities listed in this table are exceeded during the design storm event, then the channel design shall be modified until acceptable velocities are attained.

<b>Soil Description</b>	<b>Slope Treatment</b>	<b>Maximum Velocity (feet per second)</b>
Fine Sand	None	1.50
Sandy Loam	None	1.75
Silt Loam	None	2.00
Clay Loam	None	2.50
Stiff Clay	None	3.75
Sandy Soils (Easily Eroded)	Grass	4.00
Clay Soils (Erosion-Resistant)	Grass	5.00
Sandy Soils (Easily Eroded)	Rip-Rap	6.00
Clay Soils (Erosion Resistant)	Rip-Rap	8.00
Sandy Soils (Easily Eroded)	Concrete	8.00
Clay Soils (Erosion Resistant)	Concrete	10.00
Bridges and Culverts	----	8.00

## 7.4 Requirements for Channel Bends and Confluences

Erosion protection is required for all channel bends with a radius of curvature (measured along the channel centerline) less than three times the top width of flow in the channel. When required, erosion protection must extend along the outside bank of the bend and at least 20 feet upstream and downstream of the tangent points. Slope protection on the channel bottom and the inside bank is required only if anticipated flow velocities are above non-erosive levels. Exhibit 7-1 illustrates the erosion protection requirements for channel bends.

Exhibit 7-2 illustrates the minimum requirements for erosion protection and channel lining at the confluence of two open channels. Table 7-3 may be used to determine whether erosion protection is needed given the angle of intersection between the channels and the anticipated 25- year flow velocity in the tributary channel. Table 7-4 summarizes the minimum extent of erosion protection upstream and downstream of the confluence.

<b>25-Year Velocity in Tributary Channel (feet per second)</b>	<b>Angle of Intersection (<math>\theta</math>)</b>	
	<b>15 to 45 degrees</b>	<b>45 to 90 degrees</b>
$\geq 4.0$	Protection Required	Protection Required
2.0 – 4.0	No Protection Required	Protection Required
$\leq 2.0$	No Protection Required	No Protection Required

<b>TABLE 7-4: MINIMUM EXTENT OF EROSION PROTECTION AT CONFLUENCES</b>	
<b>Location</b>	<b>Minimum Distance (feet)</b>
a	20
b	larger of 50 or $0.75T_m/\tan \theta$
c	20

For both bends and confluences, the top edge of erosion protection shall extend at least as high as the 25-year design water surface elevation in the channel or two-thirds of the way up the channel side slopes, whichever is lower. A healthy grass cover must be established on the channel slope above the concrete lining.

## 7.5 Channel Backslope Drain Systems

Backslope drain systems intercept sheet flow which otherwise would flow over the banks of drainage channels leading to erosion of the side slopes. The following minimum requirements shall be applied to all backslope drainage systems.

- The minimum backslope drain pipe diameter shall be 24 inches.
- The maximum spacing between backslope drains shall be 600 feet.
- The center-line of the backslope drainage swale shall be located five feet inside the channel right-of-way (ROW) line when 20-foot maintenance berms are used. When a 30-foot maintenance berm width is used, the backslope drainage swale shall be located 7.5 feet inside the ROW line. The minimum depth for backslope drainage swales shall be 0.5 feet. The maximum depth shall be two feet.
- The minimum invert slope for backslope drainage swales shall be two-percent.
- The maximum side slope for backslope drainage swales shall be 1.5 horizontal to one vertical (1.5:1).

## 7.6 Interceptor Structures

Interceptor structures are designed to convey storm water from secondary drainage facilities such as roadside ditches into receiving channels. The main purpose of the interceptor is to prevent storm water runoff from flowing over the channel banks and down the channel side slopes. Exhibits 7-3 and 7-4 illustrate the basic configuration of a typical interceptor structure.

## 7.7 Stormwater Pollution Prevention Plans

Storm water pollution prevention plans shall be developed for all projects involving drainage improvements. These plans should focus primarily on the prevention of erosion and sediment deposition. Pollution control plans should be simple, easy to implement, and easy to maintain through the life of the construction project. Exhibit 7-5 illustrates the configuration for a rock berm, which is one of the most effective measures for preventing sediments from being carried into a creek or channel. The rock berm reduces flow velocities in small ditches, causing suspended sediments to settle out. Sediments accumulating in the area immediately upstream of the rock berm must be removed periodically in order to preserve the effectiveness of the berm and the hydraulic capacity of the ditch. A filter fabric fence is another effective measure for containing sediments.

## 7.8 Special Energy Dissipation Structures

Special energy dissipation structures such as baffled chute spillways shall be designed in accordance with procedures developed by the U.S. Bureau of Reclamation set forth in *Design of Small Dams* (U.S. Department of the Interior, Bureau of Reclamation, 1977).



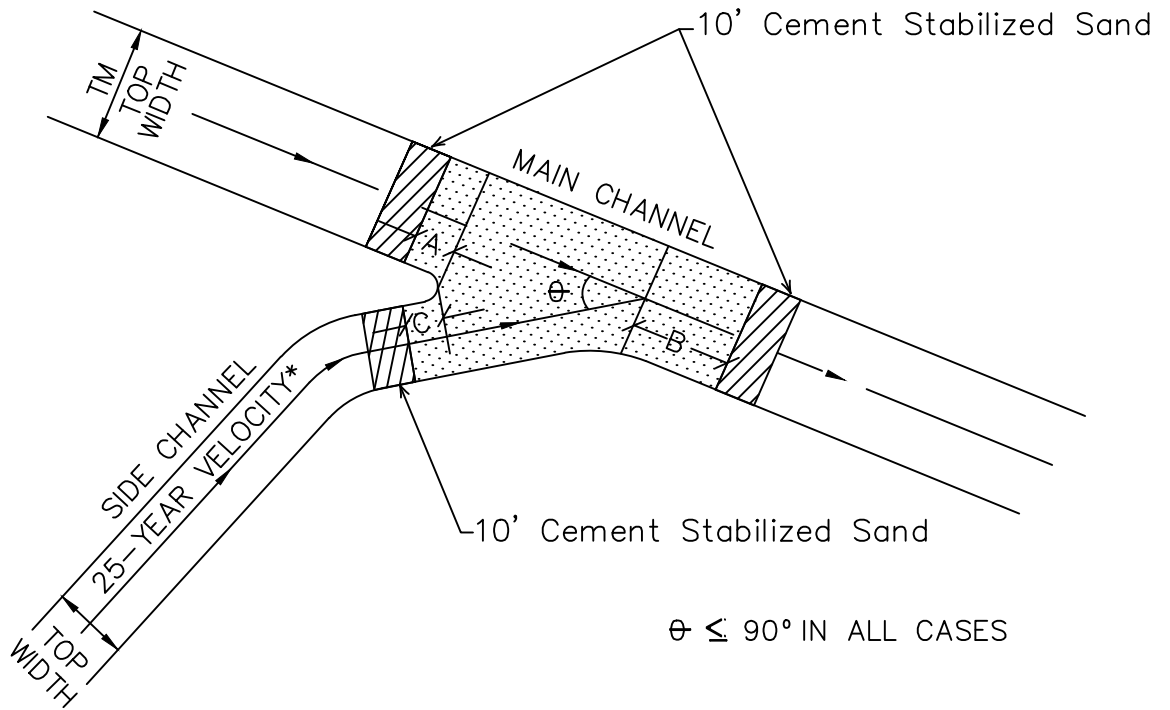

MINIMUM EXTENT OF EROSION PROTECTION

<u>LOCATION</u>	<u>DISTANCE (FT.)</u>	
A	20'	
B	LARGER OF 50' OR $0.75 \times TM \mid \tan \theta$	
C	20'	

<u>25-YEAR VELOCITY* IN SIDE CHANNEL (FEET PER SECOND)</u>	<u>ANGLE OF INTERSECTION, <math>\theta</math></u>	
	<u>15° - 45°</u>	<u>45° - 90°</u>
$\geq 4.0$ OR MORE	PROTECTION	PROTECTION
2.0 - 4.0	NO PROTECTION	PROTECTION
$\leq 2.0$	NO PROTECTION	NO PROTECTION

\* NOTE:

25-YEAR VELOCITY IN SIDE CHANNEL  
ASSUMING NO BACKWATER FROM MAIN CHANNEL.

LIBERTY COUNTY WATER  
CONTROL IMPROVEMENT  
DISTRICT # 1

SLOPE PROTECTION REQUIREMENTS  
AT STREAM CONFLUENCES

DATE AUGUST 2016

EXHIBIT NO. 7-1

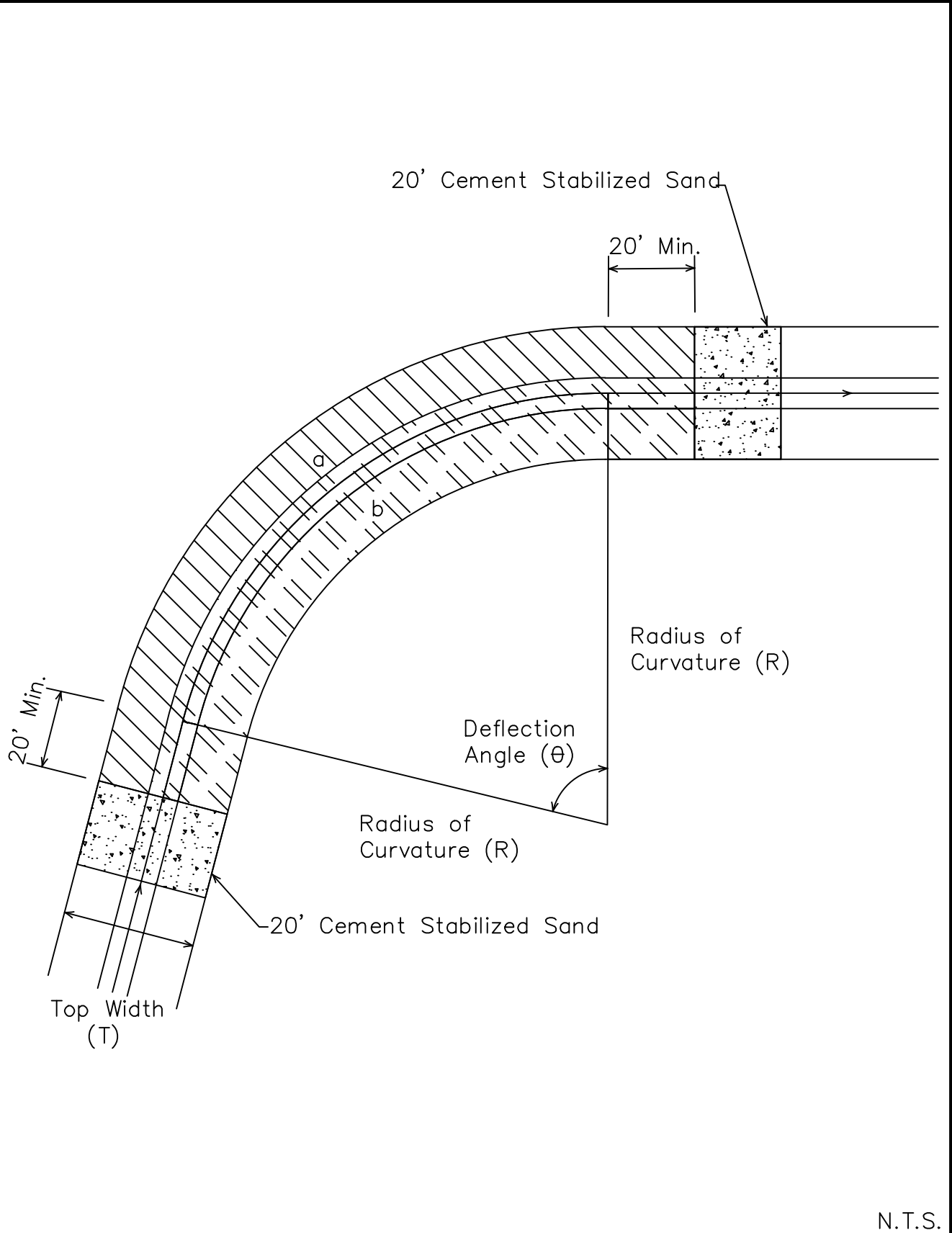

LIBERTY COUNTY WATER  
CONTROL IMPROVEMENT  
DISTRICT # 1

SLOPE PROTECTION REQUIREMENTS  
AT CHANNEL BENDS

DATE AUGUST 2016

EXHIBIT NO. 7-2

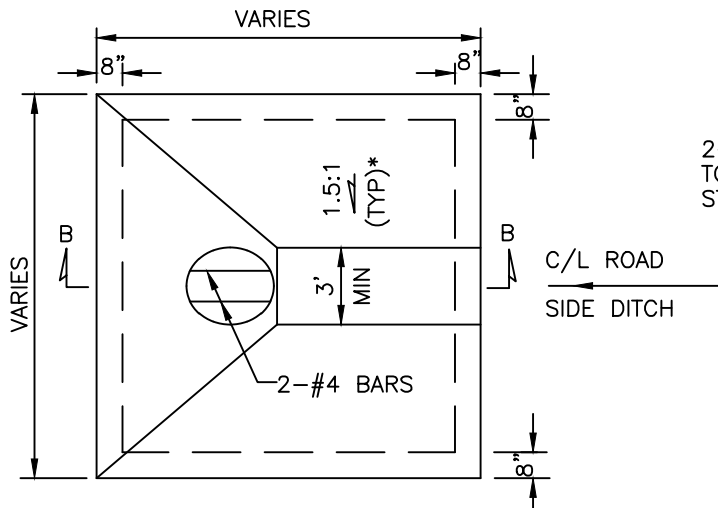

**PLAN** \* OR MATCH ROADSIDE DITCH SLOPE

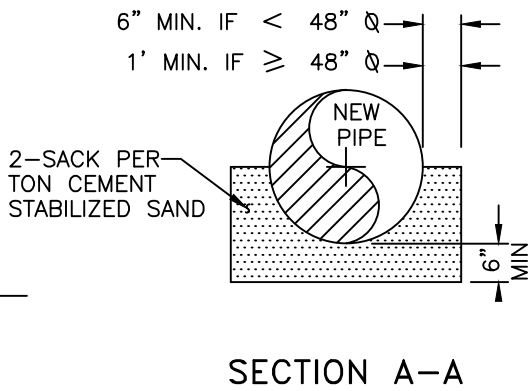

**SECTION A-A**

**C.G.M.P. SLOPE TABLE**

PIPE DIAMETER	SLOPE
24 IN.	0.6%
30 IN.	0.4%
36 IN.	0.3%
42 IN.	0.3%
≥ 48 IN.	0.2%

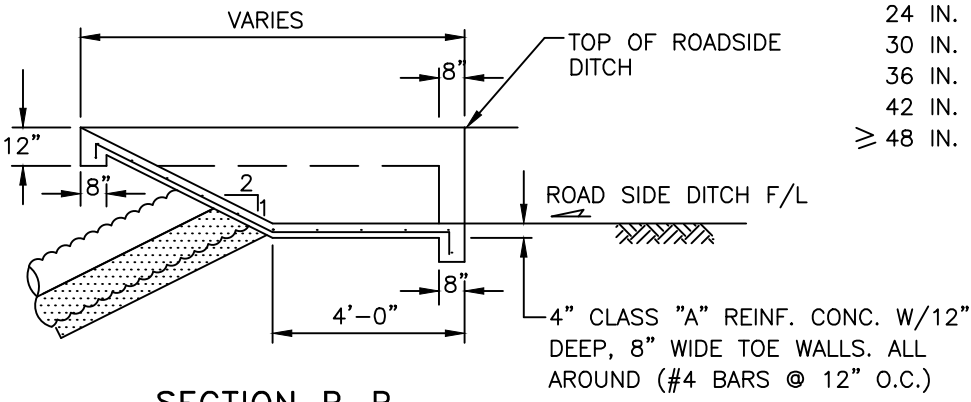

**SECTION B-B**

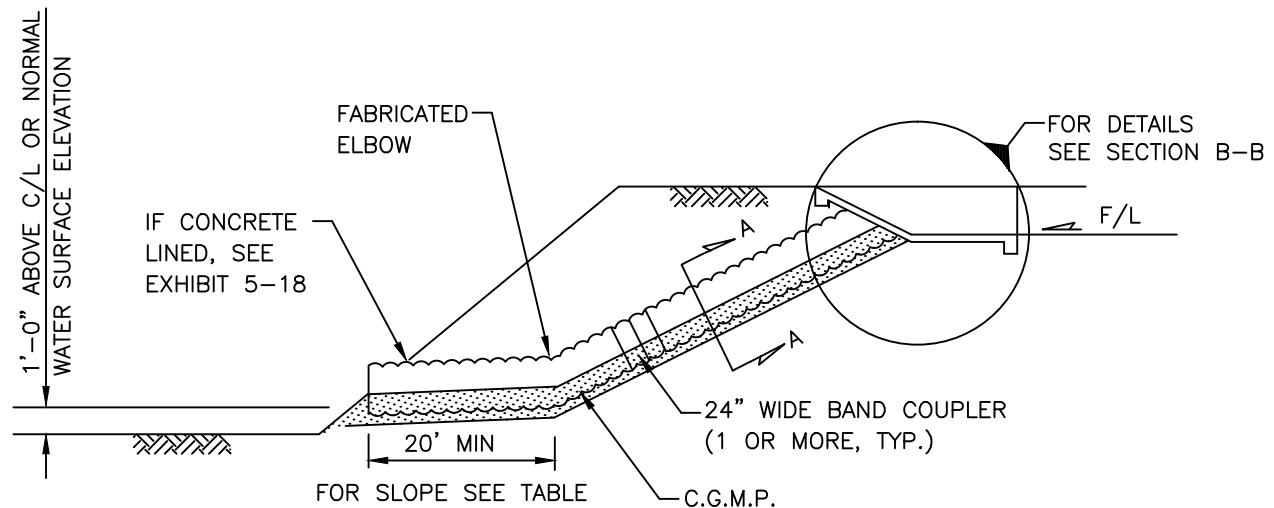

**PROFILE**

LIBERTY COUNTY WATER CONTROL IMPROVEMENT DISTRICT # 1

**TYPICAL ROADSIDE DITCH INTERCEPTOR STRUCTURE**

DATE AUGUST 2016

EXHIBIT NO. 7-3

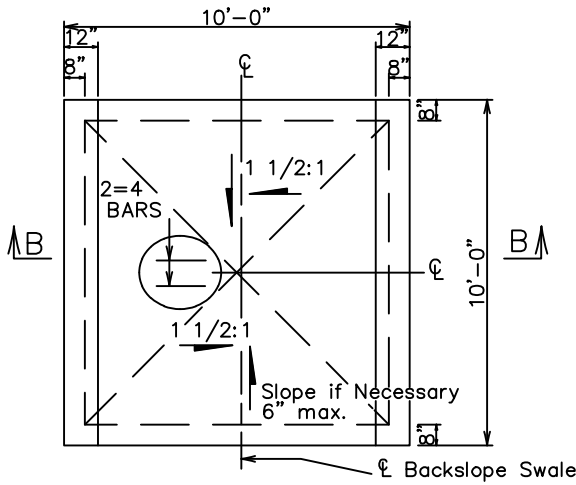

Pipe Dia.	Slope
24 in.	0.6%
36 in.	0.3%
48 in.	0.2%
60 in.	0.2%

PLAN

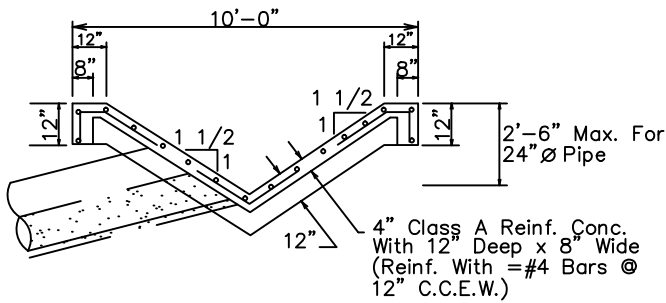

SECTION B-B

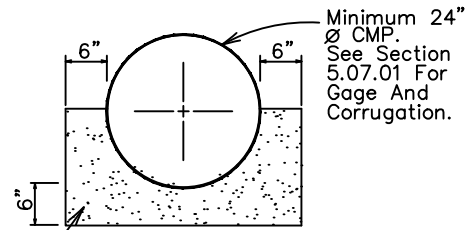

SECTION A-A

Cement Stab Sand  
2 Sacks Per Ton

Minimum 24"  
Ø CMP.  
See Section  
5.07.01 For  
Gage And  
Corrugation.

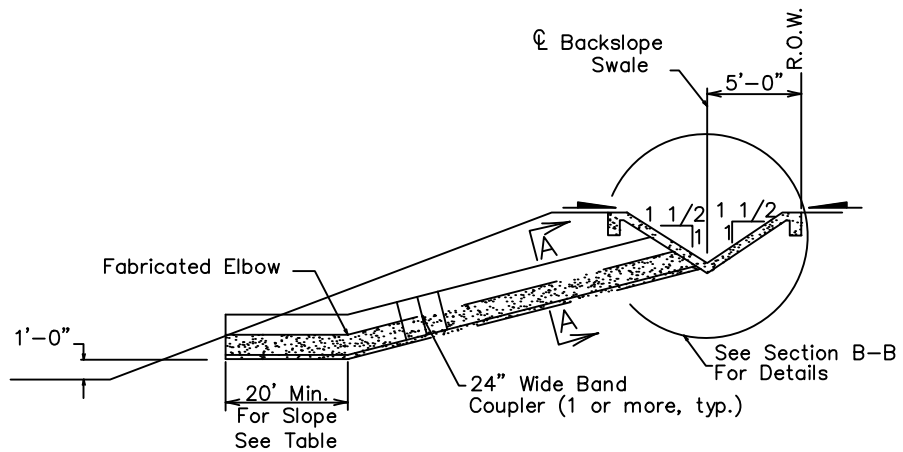

ELEVATION

LIBERTY COUNTY WATER  
CONTROL IMPROVEMENT  
DISTRICT # 1

TYPICAL BACKSLOPE INTERCEPTOR STRUCTURE

DATE AUGUST 2016

EXHIBIT NO. 7-4

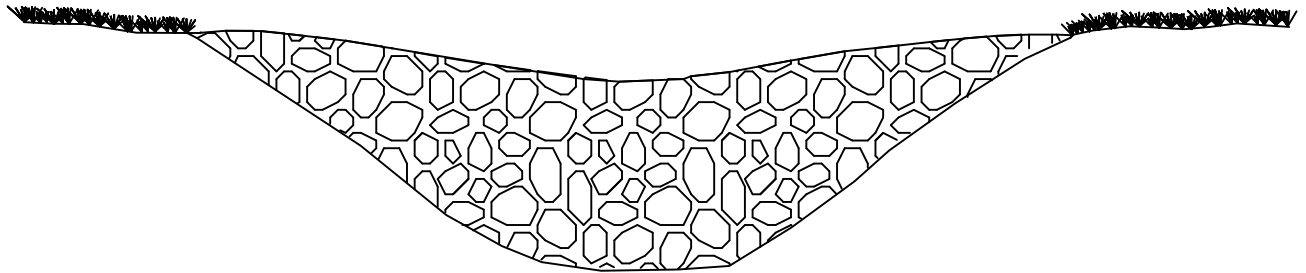

ROCK CHECK DAM

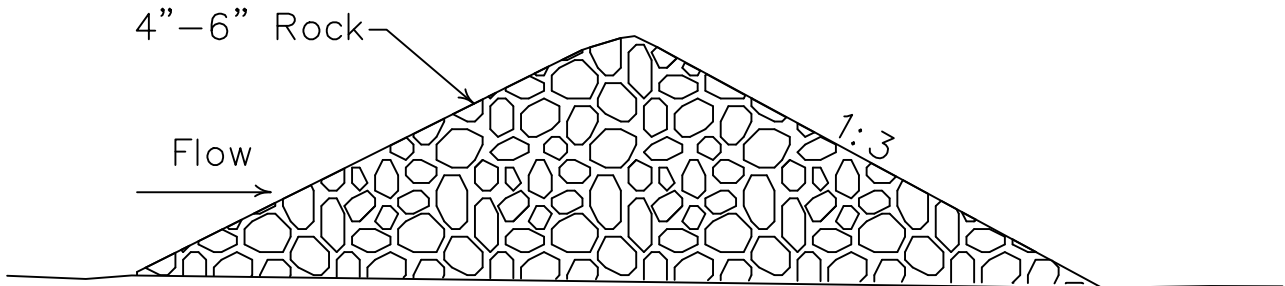

ROCK CHECK DAM CROSS-SECTION

LIBERTY COUNTY WATER  
CONTROL IMPROVEMENT  
DISTRICT # 1

TYPICAL ROCK CHECK DAM

DATE AUGUST 2016

EXHIBIT NO. 7-5

## 8 LEVEED AREAS

Flood plains cover a significant area within WCID #1 area. This area may be developed to the limits of the floodway if a levee system is constructed to protect the area from high water levels on the adjacent watercourse (usually the Trinity River). The components of the levee system shall include an internal drainage system, a levee, a pump station or adequate storage capacity, and a gravity outlet with an outfall channel to the river. The WCID #1 design criteria for each component are defined in the following sections. The county's minimum design standards shall be governed by the rules and regulations as established by the Federal Emergency Management Agency (FEMA) including any updates as they occur. In general, FEMA is not responsible for building, maintaining, operating, or certifying levee systems. FEMA does, however, develop and enforce the regulatory and procedural requirements that are used to determine whether a completed levee system should be credited with providing 100-year (1-percent-annual-chance) flood protection. These requirements are documented in Section 65.10 of the National Flood Insurance Program (NFIP) regulations. The engineer is advised to check the current FEMA rules and regulations. Maintenance of these facilities generally will not be the responsibility of WCID #1.

### 8.1 Internal Drainage System

The internal drainage system for the leveed area shall include the network of channels, lakes, and storm sewers which drain the leveed area to the outfall structure. Refer to other sections in this manual for hydrologic and hydraulic design criteria.

### 8.2 Levee System

#### 8.2.1 Frequency Criteria

The levee system shall include a levee embankment that will protect the development from the 100-year frequency flood event on the adjacent watercourse. Protection from the 100-year frequency event shall include protection from the 100-year water surface elevation on the watercourse, as well as protection from any associated wind and wave action.

#### 8.2.2 Design

Criteria General design criteria for levees in WCID #1 are shown below. However, all levees should be designed in accordance with the U.S. Army Corps of Engineers (COE) Engineer Manual EM 1110-2-1913 (30 April 2000, or most current edition). If conflicts exist between the COE manual and the criteria shown below, the WCID #1 Drainage District Engineer should be consulted for direction.

1. A geotechnical investigation shall be required on the levee foundation (the existing natural ground). Soil borings shall be required with a maximum spacing of 1,000 feet and a minimum depth equal to twice the height of the levee embankment.
2. The foundation area shall be stripped for the full width of the levee. Stripping shall include removal of all grass, trees, and surface root systems.
3. Embankment material shall be CH or CL as classified under the Unified Soil Classification System and shall have the following properties:
  - a. Liquid Limit greater than or equal to 30.
  - b. Plasticity Index greater than or equal to 15.
  - c. Percent Passing No. 200 Sieve greater than or equal to 50. A geotechnical investigation shall be required on the embankment material to determine the levee side slopes and methods employed to control subsurface seepage.
4. The embankment material shall be compacted to a minimum density of 95 percent using the standard proctor compaction test at approximately plus or minus three percent optimum moisture content. The embankment material shall be placed in lifts of not more than 12 inches thick.
5. The levee top and side slopes shall be adequately protected by grass cover or other suitable material.
6. The minimum levee top width shall be ten feet.
7. The levee side slope shall be one vertical to a minimum of three horizontal.
8. Both levees and floodwalls should provide at least 1 foot freeboard above FEMA minimum requirement. The FEMA minimum for riverine levees is as shown below:
  - a. In accordance with Section 65.10 of the NFIP, a minimum freeboard of 3 feet above the water-surface level of the base flood must be provided for riverine levees.
  - b. An additional 1 foot above the minimum is required within 100 feet on either side of structure (e.g., bridges) riverward of the levee or wherever the flow is constricted.
  - c. An additional 0.5 foot above the minimum at the upstream end of the levee tapering to not less than the minimum at the downstream end of the levee, is also required.
  - d. Occasionally, exceptions to minimum riverine freeboard requirements above may be approved if the following criteria are met:

- i. Appropriate engineering analyses demonstrating adequate protection with a lesser freeboard must be submitted.
    - ii. The material presented must evaluate the uncertainty in the estimated base flood elevation profile and include, but not necessarily be limited to
      - a) an assessment of statistical confidence limits of the 1 % AEP discharge
      - b) Changes in stage-discharge relationships and
      - c) Sources, potential, and magnitude of debris, sediment, and ice accumulation.
    - iii. It must be shown that the levee will remain structurally stable during the base flood when such additional loading considerations are imposed.
      - a) Under no circumstances will freeboard of less than 2 feet above BFE be accepted.
9. The levee shall be continuous and shall either completely encompass the development or tie into natural ground located outside of the limits of the adjacent watercourse's 100-year floodplain.
10. All pipes and conduits passing through the levee shall have anti-seepage devices, flap gates, and slope protection.
  - a. Anti-seepage devices have been employed in the past to prevent piping or erosion along the outside wall of the pipe. The term "anti-seepage devices" usually referred to metal diaphragms (seepage fins) or concrete collars that extended from the pipe into the backfill material. The diaphragms and collars were often referred to as "seepage rings." However, many piping failures have occurred in the past where seepage rings were used. Assessment of these failures indicated that the presence of seepage rings often results in poorly compacted backfill at its contact with the structure.
  - b. Where pipes or conduits are to be constructed through new or existing levees:
    - i. Seepage rings or collars should not be provided for the purpose of increasing seepage resistance. Except as provided herein, such features should only be included as necessary for coupling of pipe sections or to accommodate differential movement on yielding foundations. When needed for these purposes, collars with a minimum projection from the pipe surface should be used.
    - ii. A 0.45-m (18-in) annular thickness of drainage fill should be provided around the landside third of the pipe, regardless of the size and type of pipe to be used, where



landside levee zoning does not provide for such drainage fill. For pipe installations within the levee foundation, the 0.45-m (18-in) annular thickness of drainage fill shall also be provided, to include a landside outlet through a blind drain to ground surface at the levee toe, connection with previous under seepage features, or through an annular drainage fill outlet to ground surface around a manhole structure.

## 8.3 Pump Stations

### 8.3.1 Frequency Criteria

To prevent flooding within leveed areas, pumps are recommended (instead of only storage) to remove interior drainage when the exterior river stage reaches a level that prevents gravity outflow. In order to determine the required pump capacity so that the maximum ponding level within the leveed area will not be exceeded on the average more than about once in 100 years, the following design criteria have been developed.

The two sets of criteria provided below differ depending on whether the storm that occurs over the leveed area during high exterior river stages is an independent or dependent event as compared to the storm that produced the high river stages. In WCID #1, the levees along the Trinity River should be analyzed independently (using coincidental events, criteria 8.3.1.1) and all other levees should be analyzed dependently (using same events, criteria 8.3.1.2).

#### 8.3.1.1 Design Criteria Assuming Coincidental Events

This criterion presumes that the storm event causing a high flood stage outside of the leveed area is independent of the storm event occurring over the leveed area (e.g. a leveed area draining into the Trinity River in WCID #1). The following steps should be taken for determining the required pumping capacity.

1. Select the maximum ponding level within the leveed area that should not be exceeded more than once in 100 years on the average. Normally, this level will be equal to the maximum water surface elevations associated with the 100-year flood event computed in designing the internal drainage system (channels) of the leveed area, including the required minimum freeboard of one foot. This will be the level which, when equaled or exceeded by exterior flood stages, will prevent gravity outflow and require total pumping to remove any runoff that might occur within the leveed area.

2. From a rating or backwater curve applicable to the location on the watercourse where the gravity outflow point of the leveed area exists, determine the discharge corresponding to the maximum ponding level. Refer to Flood Insurance Study flood profiles to derive a discharge.
3. Determine the percentage of time that the discharge (obtained from Step 2 above) is equaled or exceeded. Given this percentage of time, determine the frequency of the rainfall event corresponding to the coincidental probability of these two events. (For the Trinity River, Figure 8-2 shall be used to determine directly the frequency of rainfall from the discharge corresponding to the maximum ponding elevation.)
4. Use TP-40 or other appropriate rainfall frequency curve to obtain the rainfall amounts associated with the return period (obtained from Step 3 above) to be used for determining the required pumping capacity.

### 8.3.1.2 Design Criteria Assuming Same Event

This criterion presumes the storm event causing high flood stages outside of the leveed area is the same (dependent) storm event occurring over the leveed area. The design rainfall amounts to be used for sizing the required pump capacity will be associated with the 100-year rainfall event. (See Table 4-4 for rainfall amounts derived from TP-40 and Hydro-35).

### 8.3.2 Design Criteria

All leveed areas within WCID #1 that are equipped with a pump station shall be capable of maintaining the design pumping capacity with its largest single pump inoperative. The capacity of a pump station designed under Section 8.3.1.1 shall be adequate to remove a minimum volume of water from the leveed area within 24 hours without exceeding the maximum ponding elevation within the leveed area. If a pump station is not provided, adequate storage volume below the maximum ponding level must be provided to contain the entire design storm.

The volume of runoff to be pumped shall be the greater of either:

1. The runoff resulting from the appropriate rainfall amount as determined in Step 4 of Section 8.3.1.1.
2. A minimum of 1½ inches of runoff from fully developed areas and 1 inch of runoff from undeveloped areas over the contributing watershed.

A pump station designed under Section 8.3.1.2 shall have a combination of storage volume/pumping capacity adequate to maintain the runoff resulting from the 100-year frequency

event below the maximum ponding level. The minimum pumping capacity shall be the same as number two above. All pump stations in WCID #1 shall be equipped with auxiliary power for emergency usage.

## 8.4 Gravity Outlet and Outfall Channel

An outlet shall be required to release by gravity from the leveed area through the outfall channel to the adjacent watercourse during low flow conditions on the receiving channel.

The outlet shall be equipped with an automatically functioning gate to prevent any external flow from entering the leveed area.

The outlet and outfall channel shall be designed in accordance with other portions of this criteria manual. The velocities within the outfall channel at the adjacent river shall not exceed 5.0 feet per second.

## 8.5 Review Process

When a levee system is required for development, the following information shall be submitted to the WCID #1 for review:

1. Preliminary Submittal
  - a. A vicinity map showing the proposed levee location in relation to the 100-year flood plain and floodway of the adjacent river.
  - b. The preliminary design of the levee cross-section based upon the geotechnical investigation.
  - c. The preliminary design of the pump station capacity
2. Final Submittal
  - a. The final design of the levee cross-section and location.
  - b. The final design of the pump station capacity.
  - c. The hydraulic calculations showing that the maximum ponding elevation is not exceeded within the leveed area more than once in 100 years on the average.
  - d. The construction drawings and technical specifications for the levee and pump station along with final design computations for the levee, pump station and channels. In accordance with the current Texas Water Code, Texas Commission on Environmental Quality (TCEQ) approval shall be required on the following.

- i. Levee improvement district proposed plans of reclamation.
- ii. Preliminary plans for construction of levees or other improvements.
- iii. Final plans for levees and other improvements.

## 9 DRAINAGE DESIGN CRITERIA FOR RURAL SUBDIVISIONS

### 9.1 Purpose

The WCID #1 Drainage Criteria Manual (“DCM”), adopted in \_\_\_\_\_, was intended to address design procedures for 100-year design channels and for storm sewer systems in response to the expanding urban development taking place in the District. However, this DCM did not specifically address certain drainage issued related to large lot subdivisions which typically are built in the rural areas of the county.

The purpose of this design criteria is to make available an alternative drainage procedure that can be used in the design of detention facilities for such rural-type subdivisions. Typically, such developments consist of large-acre lots with minimal drainage improvements. Little change to the natural storm runoff occurs as a result of such rural subdivisions being developed. In recognition of this, this criteria has been developed such that the effect is to reduce the amount of on-site detention otherwise required by the DCM. However, this is minimal criteria for acceptance by the WCID #1 District. Individual circumstances may warrant an enhanced drainage and/or detention system.

### 9.2 Qualifications

The following qualifications are established and must be met in order to be considered a rural subdivision for purposes of utilizing this alternative design criterion:

1. Lot size of 1 acre or greater;
2. Maximum percent impervious cover based upon lot size (see Exhibit 9-1);
3. Roadside ditch drainage system (vs. curb and gutter); and
4. No major drainage improvements that would significantly alter the natural drainage patterns in the area for large flood events.

### 9.3 Design Criteria

The following design criteria shall be utilized for rural subdivisions:

1. Minimum slab elevations – two (2) feet above natural ground, or 18” above the 100-year floodplain, or one (1) foot above the crown of any down gradient roadway, whichever is higher.
2. Roadways
  - a. R.O.W. – Seventy (70) feet wide.
  - b. Crown – Maximum of one (1) foot above natural ground.

- c. Roadside drainage system – Open ditch with 3:1 side slopes; equalizer pipes under roadway at least every 1,000 feet (minimum 24-inch diameter RCP) if roadway blocks natural drainage path.
3. Lot drainage – Swales may be constructed along lot lines to provide for minimal drainage of lots. Other than lot line swales and building pads, lots shall not be significantly graded.
4. Detention Requirements – See Exhibit 9-1 for amount of on-site detention required. Discharge pipe to be maximum 18-inch diameter RCP, or equivalent.

## 9.4 Submittals

1. Drainage area map showing existing drainage ways on or adjacent to property.
2. Map(s)/drawing(s) showing existing drainage patterns before development and proposed drainage patterns after development, for both small storm events and large storm events.
3. Preliminary (and eventually final) plat with the following plat notes:
  - a. The latest floodplain information, including Base Flood Elevation, and Flood Insurance Rate Map Panel Number and Date.
  - b. Land use within the subdivision is limited to an average imperviousness of no more than \_\_\_\_ percent. (Obtain maximum percent imperviousness from Exhibit 9-1 for the corresponding average lot size shown on the plat.) The drainage and/or detention system has been designed with the assumption that this average percent imperviousness will not be exceeded. If this percentage is to be exceeded a replat and/or redesign of the system may be necessary.
  - c. The minimum slab elevation shall be 18" above 100-year floodplain elevation, or at least 2 feet above natural ground, or 1ft above the crown of any down-gradient roadway, whichever is higher. Floodplain information note should be included.
  - d. This rural subdivision employs a natural drainage system which is intended to provide drainage for the subdivision that is similar to that which existed under pre-development conditions. Thus, during large storm events, ponding of water should be expected to occur in the subdivision to the extent it may have prior to development, but such ponding should not remain for an extended period of time. Street ponding information notes should be included

## 9.5 Technical Analysis of Detention Requirements for Rural Subdivisions

The purpose for requiring detention for developing a subdivision is to minimize the adverse impact the development has on downstream flooding. This adverse impact is caused by a combination of additional runoff, due to the reduction of infiltration caused by the increase in imperviousness associated with development, and a higher rate of runoff, due to the reduced time of concentration cause by the more efficient drainage system associated with development. The detention requirement was developed so as to minimize these adverse impacts typically with urban development (involving less than 1-acre lots).

These subdivisions also generally have less impervious cover per acre and a less effective drainage system than do urban developments. Therefore a technical analysis was performed in order to determine the appropriate detention storage that should be required for rural subdivisions in lieu of the standard detention storage that should be required for rural subdivisions in lieu of the standard detention required for urban development under the WCID #1 Drainage Criteria Manual.

## 9.6 Analysis of Runoff Volume

As the percent of imperviousness associated with a development project increases, the availability of ground surface for infiltration is reduced; and therefore, the amount of rainfall that becomes runoff is increased. An evaluation was made as to how much of an increase in runoff volume (i.e. rainfall excess) occurs as the percent imperviousness increases.

%IMPERVIOUS	RIANFALL (inches)	RAINFALL EXCESS (inches)	INCREASE IN RAINFALL	
			inches	Ac-ft/Ac
0	12.5	7.34	--	--
5	12.5	7.59	0.25	0.02
10	12.5	7.85	0.51	0.04
15	12.5	8.11	0.77	0.06
20	12.5	8.37	1.03	0.09
25	12.5	8.63	1.29	0.11

The above increases in rainfall excess show the additional runoff volume attributable to the various increases in imperviousness, and presumably the amount of detention storage in acre feet. per acre that would be needed to offset such additional runoff so as to minimize its adverse impact downstream.

## 9.7 Analysis of Runoff Rate

Usually as development occurs, the corresponding drainage system is improved, as compared to the undeveloped condition, so as to more effectively remove storm water runoff away from the property and reduce the amount and duration of standing and/or high water near residences or commercial buildings. Such an improved drainage system tends to reduce the time it takes storm water to be transported off-site, thereby causing an increase in the peak runoff rate associated with the development as compared to its undeveloped condition. However, many rural subdivisions tend to provide minimal improvements to the natural drainage system, especially as to large storms events.

Therefore, an analysis was made as to what effect rural subdivisions might have on the peak rate of runoff in order to determine an appropriate detention requirement to offset any adverse impact to downstream flooding.

The Rational Equation ( $Q = ciA$ ) is the preferred method for computing the peak runoff for an area of less than 100 acres, which applies to most rural subdivisions. The runoff coefficient,  $c$ , represents the type of land used and its slope, as well as the soil type and its rate of infiltration. Values of  $c$  can be obtained from Table 4-1 of this criteria manual. The rainfall intensity,  $i$ , depends upon the storm frequency and the time of concentration for the area. The drainage area,  $A$ , is computed in acres. An evaluation was made of three parameters used to compute the peak runoff for an undeveloped area as compared to the same area being developed with a rural subdivision. This comparison would assist in determining the amount of detention that might be needed to offset any increase in the peak runoff from an area when it is developed into a rural subdivision. Assuming there is no significant change in the overall drainage pattern of an area during a large storm event as a result of developing a rural subdivision, the size of the drainage area,  $A$ , used to compute the peak runoff should not change between undeveloped conditions versus a rural development.

The runoff coefficient  $c$ , is an estimated value; for undeveloped pastureland and cultivated land with clay soil, it is 0.30 and 0.35 respectively, per this portion of the criteria manual. For a residential subdivision with lot sizes greater than  $\frac{1}{2}$  acre, the  $c$  value is also 0.30. Thus, with a rural subdivision with lot sizes of 1 acre or larger, the runoff coefficient for the developed condition would be essentially equal to the undeveloped condition. However, the remaining parameter in the Rational Equation is the rainfall intensity,  $i$ , which is a function of the time of concentration. The extent to which the time of concentration changes due to the development of a rural subdivision depends largely upon the



improvement that is made to the natural drainage system, something that is highly site-specific. Yet it is reasonable to assume that as the lot sizes get smaller and the percent of imperviousness increases, there will be a tendency for the time of concentration to be reduced. This would result in an increase in the peak rate of runoff and require some amount of detention storage to offset this component of the adverse impact due to the development of a rural subdivision.

## 9.8 Determination of Required Detention

Based on the above analysis, the runoff volume is increased as a result of development and imperviousness increasing. On-site detention is required to reduce the impact that this increased runoff volume might have on flooding downstream. The amount of on-site detention required is equal to the increase in rainfall excess. In addition, as the percent imperviousness increases, the time of concentration tends to decrease thereby raising the possibility that the peak runoff may increase, necessitating additional detention to be required.

The amount of detention required to offset this impact is difficult to quantify, since the possible increase in peak runoff is highly site-specific. However, it is assumed that this component of the adverse impact from development will be virtually non-existent for very large acre lots (i.e. low percent imperviousness), but will become more important as the lot sizes decrease. Therefore, a comparison was made between the detention storage required under the WCID #1 Criteria Manual and that required solely due to the increase in runoff volume associated with a rural subdivision.

The criteria manual curve was based upon the equation  $S/A = \sqrt{I}$ , referenced in the criteria manual, in which the percent imperviousness,  $I$ , that was used to develop this curve, was the maximum percent imperviousness allowable for each lot size. This curve presumably reflected the detention required to offset both the impact due to additional runoff volume and the impact due to the increase in the peak rate runoff generally attributable to the drainage systems associated with urban-type subdivisions.

The Volume Only curve was based solely upon the detention requirement to offset the increase in runoff volume determined in the Section above. Based upon the two curves, the curve to be selected for this rural subdivision criteria should be expected to closely follow the runoff volume curve for the larger lot sizes and then diverge towards the criteria manual curve as the lot sizes decrease. The resulting detention storage to be required for rural subdivisions to minimize any increase in flooding downstream as a result of such a development was selected to be as follows:

<b>TABLE 9-2: COMPARISON OF DETENTION STORAGE REQUIREMENTS</b>			
<b>%IMPERVIOUS</b>	<b>DETENTION STORAGE REQUIRED (Ac-ft/Ac)</b>		
	<b>DUE TO VOL. INCREASE</b>	<b>ASSUMED FOR PEAK DISCHARGE</b>	<b>TOTAL</b>
0	0	0	0
5	0.02	0.01	0.03
10	0.04	0.05	0.09
15	0.06	0.11	0.17
20	0.09	0.20	0.29
25	0.11	0.33	0.44

This tabulated information has been transferred in Exhibit 10-2, along with the incorporation of lot sizes associated with maximum percent imperviousness.

DETENTION STORAGE REQUIREMENTS FOR RURAL SUBDIVISION

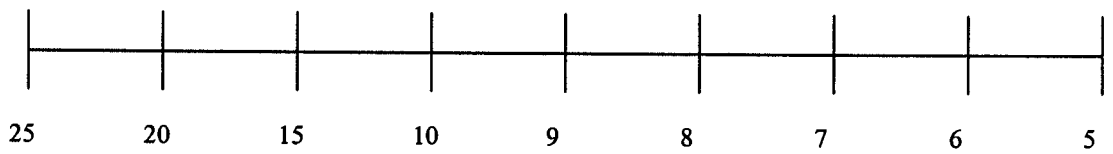
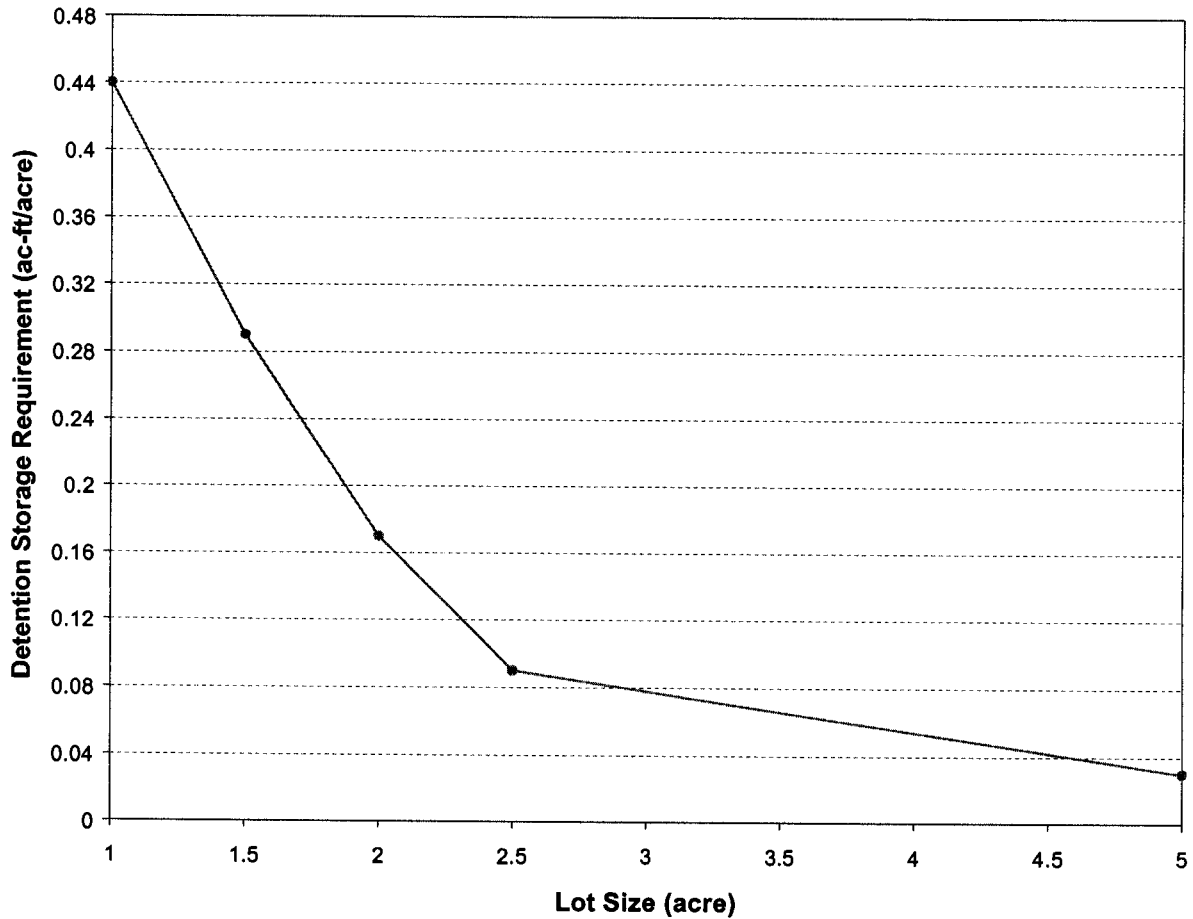

MAX. IMPERVIOUSNESS (PERCENT)

LIBERTY COUNTY WATER CONTROL IMPROVEMENT DISTRICT #1

DETENTION STORAGE REQUIREMENTS FOR RURAL SUBDIVISION

DATE AUGUST 2016

EXHIBIT NO. 9-1

COMPARISON OF DETENTION STORAGE REQUIREMENTS

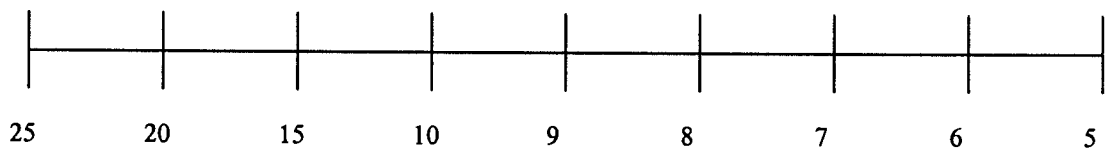
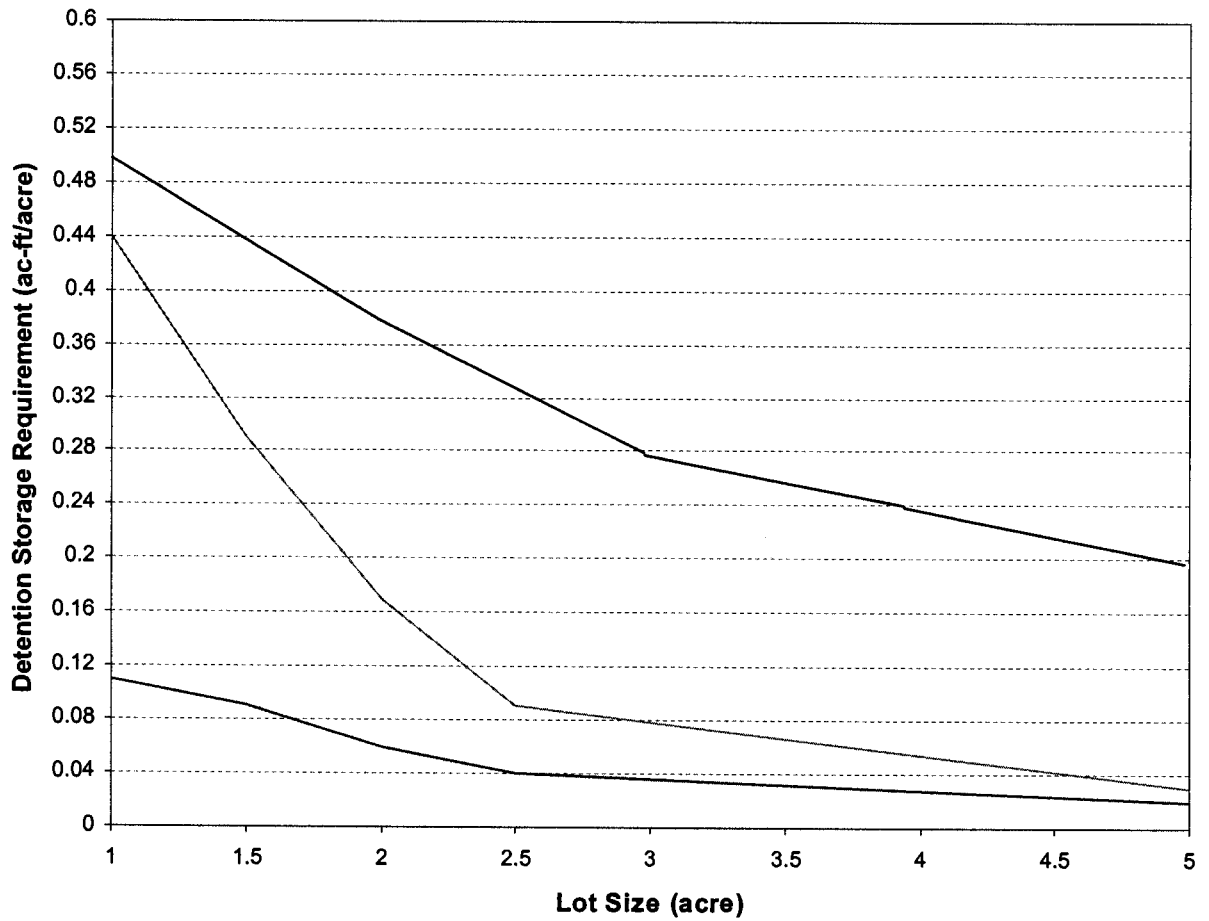

MAX. IMPERVIOUSNESS (PERCENT)

LIBERTY COUNTY WATER CONTROL IMPROVEMENT DISTRICT #1

COMPARISON OF DETENTION STORAGE REQUIREMENTS

DATE AUGUST 2016

EXHIBIT NO. 9-2