



VIRGINIA CONTROLS

MH-2000
INSTALLATION
MANUAL

Virginia Controls, Inc.
2513 Mechanicsville Turnpike, Richmond VA 23223
Tel: 804 225-5530 Fax: 804 225-0116
email: sales@vacontrols.com
email: eng@vacontrols.com

Revision 1.17.D
9 May, 2007

Member of NAEC since 1979
Member of CECA since 1998

TABLE OF CONTENTS

1. PRE-INSTALLATION INSTRUCTIONS AND NOTES	1
1.1 General Notes	1
1.2 Important Precautions And Notes	1
2. CONTROLLER INSTALLATION AND WIRING.....	2
2.1 Controller Installation	2
2.1.1 Controller Location Selection and Environment.....	2
2.1.2 Controller Grounding	2
2.2 Car and Hoistway Wiring.....	2
2.2.1 Floor Switches	2
2.2.2 Car Top Selector.....	3
2.2.3 Leveling Switches.....	3
2.2.4 Terminal Landing Normal Slowdown Switches.....	3
2.2.5 Terminal Landing Normal Limit Switches.....	3
2.2.6 Terminal Landing Final Limit Switches	3
2.2.7 Emergency Terminal Landing Limit Switch.....	3
2.2.8 Hoistway Access Zone Switches	3
2.2.9 Door Open and Close Limit Switches	4
2.3 Machine Room Wiring.....	4
2.3.1 Incoming Power	4
2.3.2 Grounding.....	4
2.3.3 Pump Motor Wiring.....	4
2.3.4 Wye-Delta Run Contact Wiring.....	5
3. START-UP INSTRUCTIONS.....	5
3.1 Before Applying Power.....	5
3.1.1 Power and Grounding.....	5
3.1.2 Input/Output Wiring.....	5
3.2 Applying Power	5
3.2.1 Motor Rotation	6
3.3 Temporary Run Connections	6
4. FINAL ADJUSTMENTS	7
4.1 Inspection Operation.....	7

4.2	Floor Position and Slowdown	7
4.3	Position Indicators.....	7
4.4	Independent Service	7
4.5	Car and Hall Calls	8
4.6	Door Operation	8
4.7	Fire Service	8
4.8	Failure Timers	8
4.8.1	Stuck Button Timer	8
4.8.2	Running Timers	8
4.9	Field Adjustable Features	9
4.10	Zoned Duplex Operation	9
4.10.1	Common Circuits	9
4.10.2	Next Car.....	9
4.10.3	Car Start	9
4.10.4	Homing	10
4.10.5	Communication.....	10
5.	MICRO-PROCESSOR HARDWARE DESCRIPTION.....	10
5.1	Major Components.....	10
5.2	CPU	11
5.2.1	LED Description.....	11
5.2.2	Reset Button	12
5.2.3	Connectors	12
5.2.3.1	Duplex Communication Connector	12
5.2.3.2	LCD Display Connector	12
5.2.3.3	Keypad Connector	12
5.2.3.4	Incoming Power Connector.....	12
5.2.3.5	Input/Output Bus Connector	12
5.3	Input/Output Boards	13
5.3.1	Addressing.....	13
5.3.2	Terminal Wiring	14
5.3.3	Input/Output LEDs	14
5.3.4	Connectors	14
6.	CONTROLLER NOMENCLATURE	15

7. PARTS LIST	15
8. CONTROLLER DIAGNOSTICS	17
8.1 Monitor Mode	18
8.1.1 Monitor Main Menu	18
8.1.2 Show I/O Status.....	18
8.1.2.1 Moving Around.....	18
8.1.3 Show Internal Memory.....	18
8.1.3.1 Moving Around.....	19
8.1.3.2 LED Description in "Show Internal Memory" Mode.....	19
8.1.3.3 Changing Data in the "Show Internal Memory" Mode.....	19
8.1.4 Go To Set-Up Mode.....	20
8.1.5 Effect of Diagnostic Modes on Scan Time.....	20
8.2 Set-Up Mode.....	20
8.2.1 How to Enter Set-Up Mode.....	20
8.2.2 How to Exit Set-Up Mode.....	20
8.2.3 Reset Settings	20
8.2.4 Change Settings	21
8.2.5 Description of Settings.....	21
8.2.6 Change Features.....	24
8.2.7 Description of Features.....	24
8.2.8 Show Hex Memory.....	28
8.2.8.1 Moving Around.....	28
8.2.9 Enter Password	28
8.2.10 Test I/O Boards.....	29
8.3 Fault Logging	29
8.3.1 Memory Addresses and Fault Log Function	29
8.3.1.1 Time Code	30
8.3.1.2 Fault Code	31
8.3.1.3 Fault Floor Code	32
8.3.1.4 Fault Status Code	32
8.3.1.5 Fault Code Example	33
9. TROUBLESHOOTING SUGGESTIONS.....	33
9.1 Locating Faults.....	33
9.2 I/O Board Replacement.....	33
9.3 Factory Assistance.....	34
9.4 Changes for Program Revisions	34
9.4.1 Program Revision 11	34
9.4.2 Program Revision 12	34
9.4.3 Program Revision 15	34

9.4.4 Program Revision 1635
9.4.5 Program Revision 1735

10. CONTROLLER MAINTENANCE 36

10.1 CPU Exchange..... 37

10.2 EPROM Memory Exchange 37

10.3 Input/Output Board Exchange 38

11. FREQUENTLY ASKED QUESTIONS 38

11.1 Questions on Field Devices..... 38

11.2 Questions on the Controller 38

1. Pre-Installation Instructions and Notes

1.1 General Notes

It is strongly recommend that you read this manual carefully before proceeding with the installation.

Important information is highlighted by the headings WARNING, CAUTION, or NOTE. These words are defined as follows:

WARNING - Warnings are used to indicate instructions which, if not followed correctly, will probably result in personal injury or substantial damage to equipment.

CAUTION - Cautions are used to indicate instructions or information which, if not observed, may result in some damage to equipment if care is not taken.

NOTE - Notes are used to indicate instructions or information which is especially helpful in understanding and operating the equipment, and which will usually speed up the installation process.

1.2 Important Precautions And Notes

The following general rules and safety precautions must be observed for safe and reliable operation of your system.

WARNING: IF YOU NEED TO CHANGE THE EPROM PROGRAM CHIP ON THE CPU BOARD, MAKE SURE YOU READ THE INSTRUCTIONS AND KNOW EXACTLY HOW TO INSTALL THE NEW CHIP. PLUGGING THE EPROM CHIP IN UPSIDE-DOWN MAY DAMAGE THE CHIP. STATIC ELECTRICITY CAN DAMAGE THE EPROM, SO AVOID TOUCHING THE PINS ON THE CHIP, AND GROUND YOURSELF (BY TOUCHING THE CONTROLLER CABINET) BEFORE TOUCHING THE CHIP OR THE CONTROLLER. DO NOT EXPOSE THE EPROM PROGRAM CHIP TO BRIGHT LIGHT, AND DO NOT REMOVE THE LABEL OVER THE EPROM PROGRAM CHIP WINDOW.

WARNING: THE ELEVATOR CONTROLLER MUST BE INSTALLED BY EXPERIENCED FIELD INSTALLATION PERSONNEL. THE FIELD INSTALLATION PERSONNEL MUST KNOW AND FOLLOW ALL THE RULES AND REGULATIONS PERTAINING TO THE SAFE INSTALLATION AND RUNNING OF ELEVATORS. ADDITIONAL INFORMATION FOR SPECIFIC DEVICES (SUCH AS THE VALVES, DOOR OPERATOR, ETC.) IS THE RESPONSIBILITY OF THE MANUFACTURERS OF THOSE DEVICES.

WARNING: THIS EQUIPMENT IS DESIGNED AND BUILT TO COMPLY WITH ANSI A17.1 AND NATIONAL ELECTRICAL CODE AND MUST BE INSTALLED BY A QUALIFIED CONTRACTOR. IT IS THE RESPONSIBILITY OF THE CONTRACTOR TO MAKE SURE THAT THE FINAL INSTALLATION COMPLIES WITH ALL APPLICABLE LOCAL, STATE AND NATIONAL CODES, AND IS INSTALLED SAFELY.

WARNING: THE 3 PHASE AC POWER SUPPLY TO THIS EQUIPMENT MUST COME FROM A FUSED DISCONNECT SWITCH OR CIRCUIT BREAKER WHICH IS SIZED IN ACCORDANCE WITH ALL APPLICABLE NATIONAL, STATE AND LOCAL ELECTRICAL CODES, IN ORDER TO PROVIDE THE NECESSARY OVERLOAD PROTECTION FOR THE CONTROLLER AND MOTOR. INCORRECT MOTOR BRANCH CIRCUIT PROTECTION MAY CREATE A HAZARDOUS CONDITION.

WARNING: PROPER GROUNDING IS VITAL FOR THE SAFE OPERATION OF YOUR SYSTEM. BRING THE GROUND WIRE TO THE GROUND STUD THAT IS LABELED "GND" OR "G1". YOU MUST CHOOSE THE PROPER CONDUCTOR SIZE. SEE NATIONAL ELECTRICAL CODE ARTICLE 250-95, OR THE RELATED LOCAL APPLICABLE CODE.

2. Controller Installation and Wiring

2.1 Controller Installation

2.1.1 Controller Location Selection and Environment

Mount the controller in a location that provides:

- adequate support for the weight of the controller,
- adequate lighting for installation and maintenance,
- convenient access for the routing of required conduits and cables,
- convenient access to other devices in the machine room,
- a minimum of vibration (supply additional bracing or reinforcement if required).

For improved controller reliability:

- Keep the machine room clean.
- Do not install the controller in a dusty area.
- Do not install the controller in a carpeted area, or area where static electricity is a problem.
- Keep room temperature between 0°C to 50°C (0°F to 122°F), and 95% non-condensing relative humidity. Extended high temperatures will shorten the life of electronic components. Provide adequate ventilation or air-conditioning as required if necessary.
- Avoid condensation on the equipment. Keep the controller away from sources of condensation and water (such as open windows) as these can create a hazardous condition and can damage the equipment.
- Do not install the controller in a hazardous location and where excessive amounts of vapors or chemical fumes may be present. A Nema 4 or Nema 12 rated enclosure can be provided if necessary.
- Make sure power line fluctuations are within $\pm 10\%$.
- High levels of radio frequency emissions may cause interference with the controller micro-processor, and produce unexpected and even dangerous results. This could be caused by hand-held communications devices used near the controller.

2.1.2 Controller Grounding

Grounding of the controller must conform to all applicable codes. Proper grounding is essential to the safe operation of the equipment. It will also reduce the likelihood of noise-induced problems, which could include CPU crashes, or I/O communication errors.

- The grounding wire should be sized per the applicable codes.
- Connect the ground to a good building ground, such as the structural steel of the building, or a cold water pipe.

2.2 Car and Hoistway Wiring

Review the schematics and field wiring diagrams before attempting to hook up the controller.

2.2.1 Floor Switches

The Floor Switches, if used, are normally open contacts that should close under each of the following conditions:

1. the car is at the slowdown point above the floor, OR
2. the car is at the slowdown point below the floor, OR
3. the car is at the floor (optional), OR
4. the car is between the up and down slowdown points of that landing (optional).

Conditions (1) and (2) are required to change the floor relays and initiate slowdown. Condition (3) is required at the terminal landings, but is optional at the intermediate landings. Condition (4) is optional.

There are many acceptable methods of providing the floor switch signals, such as by having a single Floor Switch at floor level, and an adjustable length cam on the car, or by having two Floor Switches per floor, and a fixed length cam on the car. The Floor Switches may be mounted on the car if they are in separate rows. It is recommended that the

method used allow for separate adjustment of the up and down slowdown distances. Recommended slowdown distance is about 6" for every 25fpm of car speed, for speeds of up to 200fpm. Minimum recommended target length for the floor switches is 1".

If there are short floors, refer to the schematic for special instructions, if required.

NOTE: The terminal landing Floor Switches must be maintained while the car is within door zone of the terminal landing.

2.2.2 Car Top Selector

The pulsing-type Car Top Selector provides Floor Change/Slowdown signals and Leveling signals, as shown on the car top selector sheet in the schematic. The signals should be a normally open contact that closes as described below.

1. UP SLOWDOWN closes at the Slowdown distance below the floor.
2. DOWN SLOWDOWN closes at the Slowdown distance above the floor.
3. UP and DOWN LEVEL, and DOOR ZONE/LOW LEVEL. (See "Leveling Sws")

An extra reset target is required at each terminal landing, as shown on the schematic, so that the Up Slowdown Switch is closed when the car is in the leveling zone at the top landing, and the Down Slowdown Switch is closed when the car is in the leveling zone at the bottom landing. These targets are used to reset the floor position at the terminal landings.

2.2.3 Leveling Switches

The Up Level Switch is a normally open contact that closes when the car is in the leveling zone below the floor, and the Down Level Switch is a normally open contact that closes when the car is in the leveling zone above the floor. Adjust the distance between the Up Level Switch and the Down Level Switch to be equal to the length of the leveling vane/target plus the desired Dead Zone distance (usually 1/4" to 1/2"). The actual length of the leveling target is not critical (except in some short floor situations) and is usually 6-10". Position the leveling vane/target so that when the car is floor level the Up and Down Leveling Switches are centered around the vane/target, and both switches are open.

The Door Zone Switch is a switch (or switches) activated by the leveling vane/target when the car is within 3" of floor level. If the leveling vane/target is 6" long, then only one switch is required, mounted between the Up and Down Leveling Switches, otherwise two switches wired in series should be provided.

2.2.4 Terminal Landing Normal Slowdown Switches

The Terminal Landing Normal Slowdown Limit Switch is a normally closed contact that opens when the car is closer to a terminal landing than the minimum slowdown distance. It will prevent the car from running into the terminal landing at full speed. It should be adjusted to open approximately one inch beyond the point where the normal slowdown (from the floor switches or the car top selector) is initiated.

2.2.5 Terminal Landing Normal Limit Switches

The Terminal Landing Normal Limit Switch is a normally closed contact that opens when the car has traveled 1" past floor level at a terminal landing. The car should not be on the Terminal Landing Normal Limit Switch when the car is floor level at the terminal landing. The Limit Switch will prevent the car from traveling further away from the normal area of car travel, but allows the car to run back towards the normal area of car travel.

2.2.6 Terminal Landing Final Limit Switches

The Terminal Landing Final Limit Switch, where required by code, is a normally closed contact that opens when the car has gone a considerable distance beyond floor level at a terminal landing. It will prevent any further movement of the car in either direction. Consult the applicable codes for the proper setting of this switch.

2.2.7 Emergency Terminal Landing Limit Switch

The Emergency Terminal Landing Slowdown Switch should be installed as required by the applicable codes. It is a normally closed contact that opens after the car has gone beyond the Terminal Landing Normal Limit Switch.

2.2.8 Hoistway Access Zone Switches

The Hoistway Access Limit Switches limit the motion of the car on Hoistway Access, by disabling the car if it moves away from the access floor. Install the zone switches to stop the car from running down if the top of the car goes below floor level at the top access floor, and to stop the car from running up if the car goes above the second floor while on Hoistway Access at the bottom floor.

2.2.9 Door Open and Close Limit Switches

The Door Open Limit Switch is open when the doors are fully open, and closed at all other times. It will de-energize the door open relays in the door operator when the doors have opened fully.

The Door Close limit Switch is open when the doors are fully closed, and closed at all other times. It will de-energize the door close relays in the door operator when the doors have closed fully.

NOTE: Many problems in operation can be attributed to failures in the Door Open or Close Limit Switches (including long door times, improper door operation on Fire Service, inability to go on to or to clear Fire Service, etc.) Always check the Door Open and Close Limit Switches if unusual operation of the elevator is observed.

NOTE: If a solid state door operator unit is being used, check the appropriate schematics to see if any changes are required on the actual operator. These may include changing resistors in the operator, and adding a diode for proper open and close torque.

NOTE: It is recommended that the Door Close Limit Switch be adjusted so that, as the doors are closing, the Car Door Contact closes before the Door Close Limit opens. Consult the Door Operator Manufacturer's installation instructions for further details on the adjustment of the doors.

2.3 Machine Room Wiring

Mount the controller firmly and install all required conduits before wiring the controller. Note where duct has been provided in the controller for customer access, before deciding where to locate conduit openings.

WARNING: Do not allow any metal shavings to get into relays or contactors, or in or behind the electronic components, as these could cause serious damage to personnel or the equipment.

2.3.1 Incoming Power

WARNING: THE 3 PHASE AC POWER SUPPLY TO THIS EQUIPMENT MUST COME FROM A FUSED DISCONNECT SWITCH OR CIRCUIT BREAKER WHICH IS SIZED IN ACCORDANCE WITH ALL APPLICABLE NATIONAL, STATE AND LOCAL ELECTRICAL CODES, IN ORDER TO PROVIDE THE NECESSARY OVERLOAD PROTECTION FOR THE CONTROLLER AND MOTOR. INCORRECT MOTOR BRANCH CIRCUIT PROTECTION MAY CREATE A HAZARDOUS CONDITION.

Incoming AC power wiring should be done by a qualified and licensed electrician, using the appropriate size wires for the installation. Consider the motor size and type of starter, and also the length of wire required from the main power distribution center in determining the proper wire size.

Proper branch circuit protection and disconnect device(s) must be provided, as required by applicable local, state and national codes.

2.3.2 Grounding

WARNING: PROPER GROUNDING IS VITAL FOR THE SAFE OPERATION OF YOUR SYSTEM. BRING THE GROUND WIRE TO THE GROUND STUD THAT IS LABELED "GND" OR "G1". YOU MUST CHOOSE THE PROPER CONDUCTOR SIZE AND MINIMIZE THE RESISTANCE TO GROUND BY USING SHORTEST POSSIBLE ROUTING. SEE NATIONAL ELECTRICAL CODE ARTICLE 250-95, OR THE RELATED LOCAL APPLICABLE CODE.

Proper grounding is vital for the safe operation of your system, and will also reduce the likelihood of noise-induced problems, which could include CPU crashes, or I/O communication errors.

- The grounding wire should be sized per the applicable codes.
- Connect the ground to a good building ground, such as the structural steel of the building, or a cold water pipe.
- Connect the ground on the controller to the stud labeled "GND" or the terminal "G1", as shown on the controller schematic.

2.3.3 Pump Motor Wiring

Connect the pump motor as shown on sheet 1 of the schematic.

If an Across-the-Line starter is used, then the motor leads will connect to the starter overload.

If a Wye-Delta starter is used, then the motor leads will connect to the bottom of the overload, and the bottom of the STR contactor. See the schematic for specific connection details.

2.3.4 Wye-Delta Run Contact Wiring

If a Wye-Delta starter is used, an auxiliary contact of the RU contactor may be connected in series with the up valves, to prevent the car from starting to run up until the motor is in the Delta mode. If this is desired, then connect the auxiliary as shown on the schematic, sheet 1.

3. Start-Up Instructions

If it is desired to run the car temporarily, during construction, refer to the "Temporary Run Connections" section. Otherwise proceed through each of these steps and checks before applying power.

3.1 Before Applying Power

The system has been programmed and tested for the specific elevator system, so no further changes should be made without consulting with Virginia Controls.

3.1.1 Power and Grounding

WARNING: Confirm that the voltage of the incoming power matches the controller before applying power to the controller.

Check the system for improper grounds before applying power to the controller.

With the power off, remove the fuses from the secondary of the main control circuit transformer ("CCXF"). Check the safety circuit (terminals 1 through 6, and 14, 16, 18, 19) for grounds. Using a Volt-Ohm meter connect one lead to terminal 35 (ground) and touch the other lead to each terminal to be tested. The resistance should be considerably greater than 100 ohms.

NOTE: If the fuses are not removed, the meter will read a short through the windings of the main control circuit transformer.

With the fuses still removed, apply power to the controller, and verify that the voltage at the secondary of the main control circuit transformer ("CCXF") is 110-125VAC.

3.1.2 Input/Output Wiring

NOTE: The input/output boards are equipped with quick disconnect terminal blocks. During the initial installation, you may want to remove the terminal blocks, hook up your field wires to the terminal blocks, test the field wiring for no shorts to ground or hot (terminal 1) before plugging these terminals back into the I/O boards.

With the power off, and the fuses removed, check each input point for grounds, as described in the previous section, "Power and Grounding". If a ground is observed, check the schematic to determine if this is correct (it usually is NOT!).

With the power off check each output for grounds, also check for shorts to the hot side (terminal 1). Note that some field devices, such as buzzers, will have very low resistance.

WARNING: Each output point should be isolated from ground and the hot side.

3.2 Applying Power

Remove all fuses before applying power. Reinsert the fuses, one circuit at a time, checking each circuit before adding the next.

It is recommended that you start up the controller in Inspection mode, which can be done by opening the Inspection Switch, or removing the field wire(s) from terminal 23.

WARNING: The field wire in terminal 23 is HOT. If it is removed, make sure it is insulated and labeled. Reconnect it when the car is to be taken off Inspection Operation.

3.2.1 Motor Rotation

Check that the motor is rotating in the proper direction by turning on the power, then briefly pushing in the motor starter ("PM" on across-the-line installations, "STR" on Wye-Delta installations.). Observe the direction of rotation of the motor, and if it is incorrect, reverse any two of the main power leads at the main line disconnect.

If a Reverse Phase relay is provided, check that the OK light is on when power is applied to it. If it is not, then reverse any on the two wires connected to the A,B,C terminals.

3.3 Temporary Run Connections

The following diagram show how the car may be run on temporary service, before the controller is fully installed.

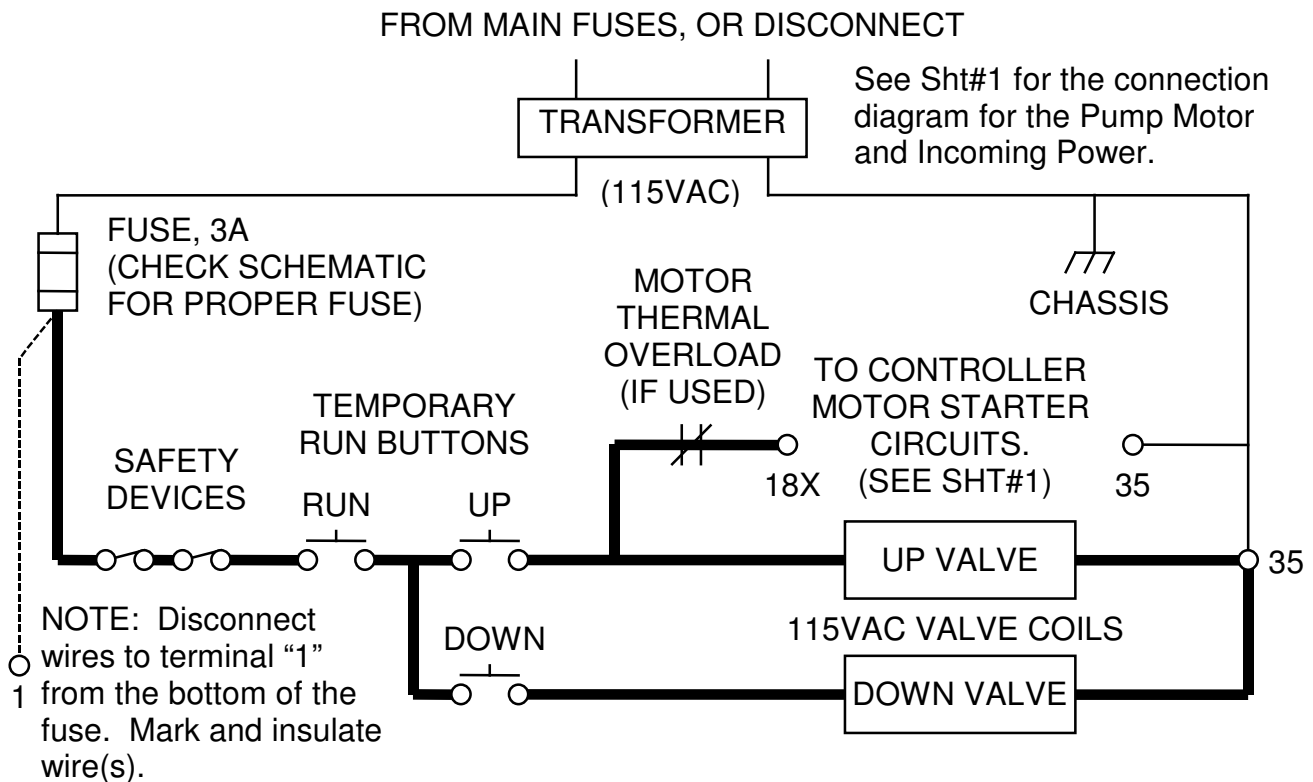

WARNING: NO SAFETY DEVICES ARE SHOWN. CONNECT ANY SAFETY DEVICES AVAILABLE IN SERIES WITH THE RUN BUTTONS, AND USE EXTREME CAUTION WHEN OPERATING THE CAR.

See the schematic for the pump motor wiring, incoming power wiring and any special requirements.

If the system uses a Soft-Start then additional connections will be required to make sure the starter energizes.
 Allen-Bradley SMC – terminal 97 on the starter must have 115VAC, to allow the fault circuit to operate properly.
 Telemechanique – the feed to the PM contactor from terminal 3 must have 115VAC
 Nordic – terminal 9 on the starter must have 115VAC

NOTE: The valves are not connected to the controller, but directly to the run buttons.

It is recommended that the wire(s) from the bottom of the fuse to terminal "1" be disconnected, marked, and insulated, to prevent any power being sent to the normal controller circuits.

When the car is sufficiently completed to allow it to be run from the inspection station, reconnect all field devices as shown on the controller schematic field sheets. Reconnect the wire(s) from terminal "1" to the bottom of the fuse (see above).

4. Final Adjustments

When the controller is ready to be run in automatic, it is recommended that a factory reset be performed. This can be done by (1) Turning off the power; (2) Put the car on inspection; (3) Jump terminals 1 to 21 and 1 to 22; (4) Turn on the power for 15 seconds; (5) Turn off the power, and remove the jumpers, and continue as normal.

Alternatively, the keypad can be used. Press "Nxt" until the menu item "Go to Setup Menu" is displayed, then press "Ent" 3 times. (The screen will show a warning, then go to the Setup Menu, where the first item is Reset (factory Settings). The password "911" should be entered when requested. Press "Esc" to return the elevator to service.

As the wiring is completed, the following modes of operation can be checked and used.

4.1 Inspection Operation

To run the car on Inspection Operation, the safety string (including the door contacts, terminal landing normal slowdowns, normals and finals) should be operational.

The Doors Closed relay (DC) should be energized, and the corresponding input on the I/O board should be on.

The Inspection Input (normally Input A12) should be de-energized.

Pressing the Up Run and Run Buttons will energize the 1st Landing Car Call Button Input, which will cause the Up Direction and Door Close outputs to come on.

When the Doors Closed input comes on, the up run outputs for the motor and the valves will energize, and the car will run up.

(Down direction is similar)

4.2 Floor Position and Slowdown

The program is in EPROM (Electrically Programmable Read Only Memory). The floor relays and fire service relays are maintained in the micro-processor RAM memory and are held through power loss by a capacitor on the CPU board. The floor relays may need to be reset when the controller is initially installed. This will be accomplished when the elevator hits any floor switch. With a pulsing type selector, the floor position is reset at either terminal landing when a slowdown switch and a leveling switch are energized at the same time. Note: If floor switches are used, they should be maintained at the terminal landings, so that they are energized whenever the car is in the slowdown zone at that landing.

Make your final adjustments for the slowdown targets. All slowdown distances should be equal.

If a pulsing selector arrangement is used, remember to install the reset targets at the terminal landings.

4.3 Position Indicators

Verify that the floor position changes properly as the car goes past each landing. Floor change should take place at the slowdown point before each landing.

If the Position Indicator does not match the actual car position, run the car to a terminal landing reset target (with pulsing selector only).

4.4 Independent Service

Independent Service is useful for final tune-up of the car. Initiate Independent Service by turning on the Independent Service Switch in the car, or by jumping the Independent Service Switch input.

On Independent Service, the hall calls will be ignored (On version 14 and later, the hall calls will be canceled). The car will run from car calls only, and will park with the doors open. To close the doors, jump terminal 1 to terminal 28 ("Door Close Button" input). This jumper may be left on, if desired, so that the car may be run by jumping the desired car call input.

NOTE: To run the car from the machine room, without the doors opening, remove the wire from the Door Open Limit Sw Input (which is usually wired to terminal 7X).

NOTE: If the car does not run, verify that no door protective device (Door Open Button, Safety Edge, Electric Eye, Infra-red Curtain) is holding the doors open. Verify that the car is not stuck in leveling. Verify that the Door Close Button input is energized.

4.5 Car and Hall Calls

To observe the operation of the car and hall calls, the system must be in automatic operation (LEDs L1 and L2 on the CPU board should both be on.) Verify that all car and hall calls work.

NOTE: On DUPLEX systems the doors must be allowed to operate for the calls to be canceled properly.

Each call will be canceled when the car initiates slowdown for the call, or when the doors start to re-open for the call if the car is already at the floor.

If both hall calls are entered at an intermediate landing, and no other calls are in the system, the doors will close after answering one of the calls, then re-open in response to the other call.

4.6 Door Operation

Verify that any required changes to the door operator, as shown on the door operator drawings, have been made correctly.

Check the Door Open and Close Limits for proper operation.

If the doors attempt to open for too long, the open cycle will be stopped. The car will then respond to other calls, and try to open the doors again.

If the doors fail to close properly within a preset time, the doors will re-open, and try to close again. If the doors closed, but the car does not run in response to a call, the doors will re-cycle, and the car will try again.

For very slow doors, the Door Stuck Timer, which initiates the Door Open and Door Close Fail, as described above, may need to be increased. It is normally set at 15 seconds.

Operation of Electric Eye on Nudging. If Nudging Operation is activated, the Electric Eye will be disabled when the Nudging Timer has tripped AND the doors are fully open. If the nudging timer trips while the doors are closing, the Nudging Buzzer will turn on, and the Electric Eye will remain active. If the doors do reopen fully, then the Electric Eye will be cut out. The Safety Edge Input remains active on nudging.

4.7 Fire Service

Fire Service Phase 1 may be initiated by turning off a Smoke Sensor input, or by energizing the Hall Fire Switch "On" input.

Confirm that the car returns to the correct Main and Alternate landings.

Confirm that the car operates as required on Car Fire Service (Phase 2) operation.

NOTE: To reset Hall Fire Service (Phase 1), most codes require the Bypass input be energized. To disable Hall Fire Service, jump the Hall Bypass input on.

NOTE: If Car Fire Service (Phase 2) appears to be operating incorrectly, check the Door Open and Close Limits for proper operation. Most codes require that the doors be fully open before allowing a change in the mode of operation on Car Fire Service. Most codes require that Hall Fire Service (Phase 1) be in effect for the car to return automatically to the main fire landing when the Car Fire Switch is turned to the off position.

4.8 Failure Timers

4.8.1 Stuck Button Timer

If a car or hall call button remains on for an adjustable time, and other calls are registered, the stuck button call will be ignored, and the car will answer the other call(s). The car will return to the stuck button call as it answers other calls, and the stuck button timer sequence will be repeated.

4.8.2 Running Timers

If the car runs up for an adjustable time, without changing floors, then low oil/shutdown operation will be initiated. The Shutdown LED on the CPU will come on. The Shutdown could be caused by a low oil level; a problem with the motor starter circuit(s); or a problem with the up valve circuit(s). The car will stop running up, then return to the lowest landing and cycle the doors. It will then be shut down, with only the Door Open Button and door protective devices being operational. The fault can be reset by cycling the Main Line Disconnect Switch, or by putting the car

on "Inspection" then back to "Automatic". NOTE: If a Reverse Phase Relay or Emergency Power circuitry is supplied, these will also initiate a shutdown signal if the inputs are not energized.

If the car is between floors, and runs down for too long while looking for a floor, it will stop, and return to normal operation.

4.9 Field Adjustable Features

Refer to the section on changing Settings and Features to see the features that are adjustable.

The controller is already set up for the specific job when it is shipped from Virginia Controls. It is recommended that the "Reset Settings" sequence be performed when the controller is first powered up. This sequence is described in the section Controller Diagnostics/Set-up Mode/Reset Settings, or in Controller Maintenance/Frequently Asked Questions/How Do I Reset All Settings and Features Back to the Original Values.

The settings or features that most often need adjustment are the door times, and fire service return floors.

4.10 Zoned Duplex Operation

The Duplex System will keep one car at the Main Dispatch Landing, as the Lobby Car, and allow the other car, or the Free Car, to stop at it's last call. The Lobby Car will answer calls in the Lobby Zone, and the Free Car will answer all other calls. The Lobby Car may leave the lobby to assist the Free Car under various load conditions as described below under Start Control. The "Lobby Zone" is an adjustable group of landings but the factory preset value is normally the Lobby/Main landing and any landings below the Lobby/Main landing. All other landings are in the "Upper Zone". If a car is "Next" in a zone, then it will answer calls in that zone, otherwise it will answer calls in the other zone. If both cars are in service, a car will always be homed to the Main Lobby level.

4.10.1 Common Circuits

Several circuits need to be energized when either car is on. These include the Hall Calls, Fire Service, and some other circuits that may be required for a particular job (such as Emergency Power, Hospital Service, etc.). These circuits get their power from either car by means of the VR (Voltage) relay. (See the schematic.)

Install each car separately. The Hall Calls and Hall Fire signals may be wired to either car, then cross-connected to the other car.

WARNING: Be careful not to mix the power supplies from one car with the other car. Signals that are common to both controllers must be connected to a common supply, as shown on the schematic.

4.10.2 Next Car

A "Next Car" is selected for the Lobby Zone and the Upper Zone. This car will be assigned hall calls in the respective zone. The other car may answer calls in a zone where it is not "Next", but it will not normally be sent to calls outside its zone. The "Next Car" assignments can be seen in the communication signals (see below).

4.10.3 Car Start

The Car START feature controls when the car will respond to registered Hall Calls by controlling the internal direction circuits. When the START circuit is energized the car will immediately begin to respond to Hall Calls. There is a separate start circuit for the Lobby Zone and the Upper Zone. A car will always respond to Car Calls immediately.

The START circuit is energized if ANY of the following conditions are true:

1. The car is Next in that zone.
2. The car is in the other zone, and is NOT next in that zone. (This means that both cars are in the other zone, so the car that is not next in the other zone will be pulled into this zone.)
3. The call(s) in this zone have been registered for a preset time. (This allows the other car to help in heavy traffic situations.)
4. The car is not in normal group operation (Communication Output Point 5 will be off).
5. The other car is not in normal group operation (Communication Input Point 5 will be off).
6. The other car has a call behind it, (Communication Input Point 5 will be flashing).
7. Emergency Power is activated, and this car is assigned to run.

4.10.4 Homing

If there are no cars at the Main Dispatch landing, the "Next" car in the Lobby Zone will home, or return, to the Main Dispatch Landing. If there is no "Next Car" in the Lobby Zone, then the first available car will home to the Lobby. If desired, the "Free" car can be set up to home to a specific (adjustable) landing in the upper zone, or to home to the Main landing. (See the separate description on Feature Adjustments.)

A car will home if the following conditions have been met for 2 seconds:

1. The car is in group operation (not on Inspection, Independent Service, Fire Service, Load Weighing etc.).
2. The Stop Sw is not thrown.
3. The car is not stuck.
4. The doors are closed.
5. The car is not at the Main Dispatch Landing.
6. The car is not running.
7. The other car is in group operation.
8. The other car is not next in the Lobby Zone.
9. The other car is not running down.
10. The other car is not homing.

4.10.5 Communication

Confirm that the termination jumpers have been installed to connect the termination resistors. These are two small jumpers just below the Duplex Communication Connector block in the upper left corner of the CPU. (Refer to the diagram of the CPU below)

Connect the communication cable from the Duplex Communication Connector block of one car to the other car. The negative terminal on one car only should be connected to ground.

When both cars are in operation, the LED L4 should flash repeatedly. This indicates the two CPUs are communicating properly.

If LED L4 is not flashing, check the communication cable, the termination jumpers, and the grounding. If these look OK, but the CPUs are not communicating, do a factory reset on both cars. Memory location 0350 shows the number of successful communications (it should be constantly changing when both cars are operating) and memory location 0351 shows the number of bad communication attempts (this should be 0). (Note: these memory locations may change. If you are having communication problems, you can check with Virginia Controls for the correct memory location for these functions.)

5. Micro-Processor Hardware Description

5.1 Major Components

The controller consists of the Micro-Processor system, Power Supply section, and Relay Interface.

The Micro-Processor system consists of the Central Processor Board (CPU), which has the micro-processor central processing unit, the EPROM memory chip, and the appropriate hardware to communicate to the LCD display, Keypad, and Input/Output boards.

The program is in EPROM (Electrically Programmable Read Only Memory). The floor relays and fire service relays are maintained in the micro-processor RAM memory and are held through power loss by a capacitor on the CPU board. The floor relays may need to be reset when the controller is initially installed.

The Power Supply section includes the required transformers and fuses to power the Micro-Processor system and the Relay Interface.

The Relay Interface includes the required relays and contactors to interface the field signals and devices to the micro-processor. This usually includes a printed circuit board for normal signals, as well as other relays or contactors for signals required for each specific job.

5.2 CPU

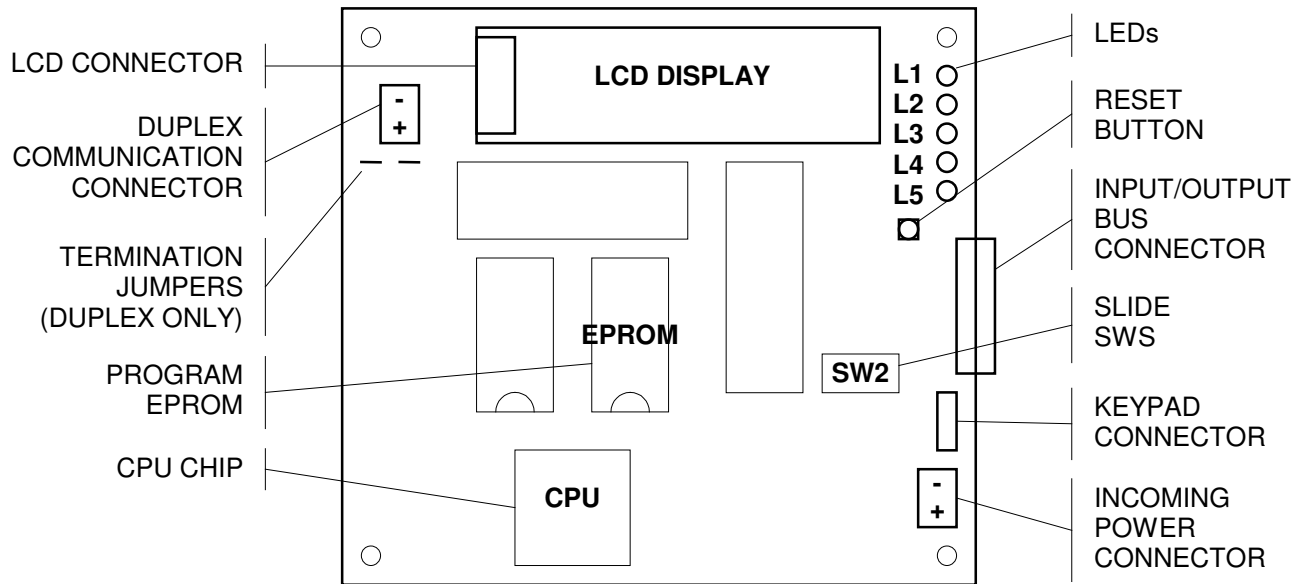

The Central Processing Unit (CPU) board contains the hardware that controls the inputs and outputs which control the elevator. This section describes the major components on the board, and the function of the connectors and LEDs. The operation of the Slide Switches labeled SW2 on the CPU are described below.

5.2.1 LED Description

NOTE: If the diagnostic mode is changed to monitor the Internal Memory, or the Setup Mode is selected, then the operation of the LEDs will change, as described in the appropriate sections.

There are five LEDs located at the upper right edge of the CPU board. The function of these LEDs during normal monitoring is noted on the schematic. The normal description for these LEDs for a SIMPLEX is as follows:

- L1 "Inspection Operation". This LED should be lit during normal operation. It will go out when the car is on Inspection Operation.
- L2 "Automatic Operation". This LED should be lit during normal operation. It will go out when the car is on Inspection Service, Independent Service, Fire Service, Low Oil Shutdown, or any other mode that will cause the car to ignore Hall Calls.
- L3 "Fire Service". This LED should be off during normal operation. It will be lit if the car is on Fire Service Phase 1 (Hall) or Phase 2 (Car).
- L4 "Shutdown". This LED should be off during normal operation. It will be lit if the Up Run timer indicated the car has been running up for a preset adjustable time without passing a floor. This could be caused by a low oil level; a problem with the motor starter circuit(s); or a problem with the up valve circuit(s). The car will stop running up, then return to the lowest landing and cycle the doors. It will then be shut down, with only the Door Open Button and door protective devices being operational. The fault can be reset by cycling the Main Line Disconnect Switch, or by putting the car on "Inspection" then back to "Automatic". NOTE: If a Reverse Phase Relay or Emergency Power circuitry is supplied, these will also initiate a shutdown signal if the inputs are not energized.
- L5 "Watchdog". This LED will flash regularly if the CPU is operating properly. NOTE: The LED will stop flashing if the diagnostic system is put in the Setup Mode. If the system is in the normal run mode, and this LED stops flashing, reset the CPU by cycling the Main Line Disconnect Switch, or pressing the Reset Button on the CPU.

WARNING: Pressing the Reset Button will cause the car to stop immediately.

NOTE: For a DUPLEX, the LEDs L1, L2 and L5 are as described above. L3 monitors the "Shutdown" (as described above for L4). L4 monitors the communication between the cars, and should pulse regularly to indicate normal communications.

5.2.2 Reset Button

The Reset Button is located just below and to the left of LED L5. It is used to reset the CPU if a lock-up occurs (such as if LED L5 stops flashing when in the normal operating mode).

NOTE: The Reset Button should not normally need to be used.

WARNING: Pressing the Reset Button will reset the CPU, causing all outputs to be turned off and the car to stop immediately.

5.2.3 Connectors

5.2.3.1 Duplex Communication Connector

The Duplex Communication Connector is a terminal block located in the upper left corner of the CPU board. A shielded twisted pair is used to connect the two CPU boards together. The shield is connected to the CPU board mounting screw (which is grounded) at ONE END OF THE CABLE ONLY. The termination jumpers next to the connector are factory installed on duplex systems.

5.2.3.2 LCD Display Connector

The LCD Display Connector is located at the top left of the CPU board. The LCD display is mounted directly on the connector. The LCD display can be removed for replacement. If it is removed, then the diagnostic display should be set to the monitor mode, and the screen be left blank (such as when the power is cycled) or the banner should be displayed (press "ESC" until the screen shows "VirginiaControls" on the top line). The LCD display AND the Keypad should be removed together. (If the LCD display is removed, and the keypad is activated, the CPU may lock up.)

5.2.3.3 Keypad Connector

The connector for the Keypad is located at the right, directly above the incoming power terminals. The connector is a 10pin connector. If the connector is removed, make sure the connector is replaced properly. Make sure the connector is centered on the pins (not one row too low or too high) and that the cable leaves the connector to the right. The wire on the bottom edge of the connector on the CPU board should go to the right side of the connector on the keypad, and the wire on the top edge of the connector on the CPU board should go to the left side of the connector on the keypad.

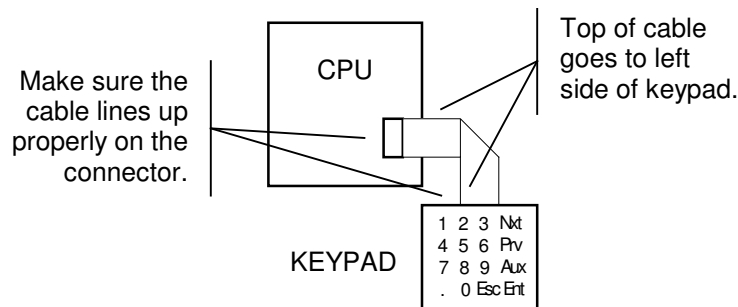

If the cable is plugged in incorrectly, then the keypad will not respond properly. Check the "Nxt" and "Prv" keys to see if the keypad cable is connected properly, since these keys should scroll through the menu items.

5.2.3.4 Incoming Power Connector

The Incoming Power Connector is a terminal block located in the bottom right corner of the CPU board. The incoming power is 12VDC from the power supply located near the CPU. If the CPU board is replaced, the incoming power wires must be connected to the correct terminals. The upper terminal is "-" and the lower terminal is "+".

5.2.3.5 Input/Output Bus Connector

The Input/Output connector is on the rear of the CPU board at the right edge. A ribbon cable connects to the first I/O board. All I/O boards are connected to this connector by means of a daisy-chain ribbon cable, that has a connector for each I/O board in the system.

5.2.4 Slide Switch SW2

The SW2 Slide Switch is used to set various operating modes or features in the CPU. Currently only the first switch is used. If the other switches are assigned a particular function, this will be indicated on the paperwork for the particular job.

If switch 1 is ON, then the LCD Display will show the "Banner" screen on power up.

If switch 1 is OFF, then the LCD Display will be blank on power up. To activate the display and show the Main Menu, press any key. This mode should be used if the LCD is to be removed for any reason. It is recommended that if the LCD Display is removed that you also remove the keypad, since pressing a key with the LCD removed could lock up the CPU as it attempts to write to the LCD Display.

5.3 Input/Output Boards

TYPICAL I/O BOARDS

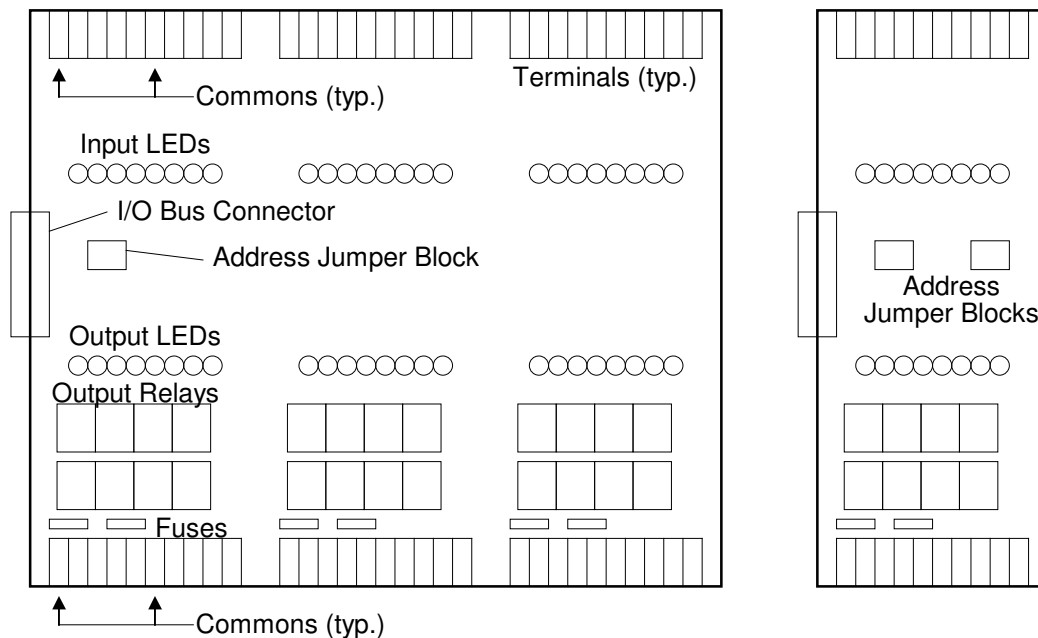

Input/Output boards are used to connect the CPU with the field devices. All inputs (unless otherwise stated) are 115VAC, and outputs (unless otherwise stated) are dry relay contacts.

The boards are available as 8-Input and 8-Output, or 24-Input and 24-Output boards.

All inputs and outputs have individual LED indicators.

Wiring is done to the removable terminal blocks at the top and bottom of the IO boards.

Fuses are provided on the I/O board for all outputs. The fuses are located at the bottom of the board, just above the terminal blocks. Each fuse protects four output points, either points 0,1,2,3 or points 4,5,6,7. The normal fuse size is 1 amp, though the fuses controlling the valve solenoids may need to be increased to 1.5 amps if a high current valve solenoid is used.

5.3.1 Addressing

Each Input/Output board is given a unique address by means of the jumper plugs in the middle of the board. The schematic shows the address of each board. If a board is replaced, the board must be set up with the SAME ADDRESS as the board it was replacing. 24point I/O boards have one jumper, which is set to A, B, C, or D. (24point I/O boards automatically use addresses 1,2,3 for the three groups of 8 I/O, with group 1 assigned to the left I/O group, group 2 is the center group of 8 I/O, and group 3 is the right group of 8 I/O.) 8point I/O boards have two jumpers, which are set at A,B,C,D for the first jumper, and 1, 2, 3, 4 for the second jumper. If an 8point I/O board is set up with the same letter address as a 24point I/O board, the number jumper must be set to 4, since the 24point I/O board uses addresses 1,2,3.

The address of each I/O point is determined by the Board Letter (A,B,C,D), the Board Number (1,2,3,4), then the Point Number (0,1,2,3,4,5,6,7). This address is used in the Monitor I/O Menu to show the I/O status.

5.3.2 Terminal Wiring

Wiring to the Inputs is at the TOP of the I/O board, and wiring to the Outputs is at the BOTTOM of the I/O board. The terminal blocks are removable, so BEFORE power is applied, remove the terminal blocks and check for grounds at the terminal blocks.

Note also the location of the COMMONS, as shown on the schematic. The far left terminal is the common for the four I/O points to its immediate right, and the sixth terminal from the left is the common for the four I/O points to its immediate right.

WARNING: Be very careful not to jump to a common when you intended to jump to an input or output, as this could damage the controller or other equipment.

Typical I/O Board Terminal Block Layout

Com	0	1	2	3	Com	4	5	6	7
-----	---	---	---	---	-----	---	---	---	---

5.3.3 Input/Output LEDs

Each Input and Output point has its own LED indicator. These are located towards the center of the board, and are on the low voltage/CPU side of the optical isolator in the I/O circuitry.

5.3.3.1 Input/Output Naming Conventions

Each Input or Output is mapped to a specific address in the CPU. The address of each Input/Output point is based on the address of the board and on the location of the point on the board.

The address of each I/O point is determined by the Board Letter (A,B,C,D), the Board Number (1,2,3,4), then the Point Number (0,1,2,3,4,5,6,7). This address is used in the Monitor I/O Menu to show the I/O status.

For 8 point boards, the Board Letter and Board Number are both set by the two sets of address jumper blocks on the board. The point number is 0 to 7 starting from the left. These correspond to the LED names silk-screened on the board. L10=Input point 0, L11=Input point 1, etc. L20=Output point 0, L21=Output point 1, etc.

For 24 point boards, the Board Letter is set by the address jumper block on the board. The Board Number and Point Number are determined by the location of the group of points on the board. The Board Number is 1 for the far left group, 2 for the center group and 3 for the right group. The Point Number is 0 to 7 starting from the left. These correspond to the LED names silk-screened on the board. L10-L17=Input points 10-17, L30-L37=Input points 20-27, L50-L57=Input points 30-37, L20-L27=Output points 10-17, L40-L47=Output points 20-27, L60-L67=Output points 30-37.

5.3.4 Connectors

The connector on the back left of the I/O board is for the I/O bus from the CPU board. It is connected in a daisy chain to the other I/O boards and back to the CPU board.

6. Controller Nomenclature

<u>SYMBOL</u>	<u>DESCRIPTION</u>	<u>PARTS LIST ITEM NO</u>
C	DOOR CLOSE RELAY (in MODSS on top of the car, if used)	A5
DC	DOOR CLOSED RELAY (on Printed Circuit board)	A1
DL	DOWN LEVEL RELAY (on Printed Circuit board)	A1
ES	EMERGENCY STOP SWITCH RELAY (OPTIONAL) (on Printed Circuit board)	A1
ESB	EMERGENCY STOP SWITCH BY-PASS RELAY (on Printed Circuit board)	A1
FSD	FAST SPEED DOWN RUN RELAY (on Printed Circuit board)	A1
FSU	FAST SPEED UP RUN RELAY (on Printed Circuit board)	A1
IAS	INSPECTION ACCESS RELAY (on Printed Circuit board)	A1
O	DOOR OPEN RELAY (in MODSS on top of the car, if used)	A5
PM	STARTER (ACROSS THE LINE START)	B4/B7
PMP	PUMP MOTOR PILOT RELAY (110VDC) (on Printed Circuit board)	A2
RU	MOTOR RUN CONTACTOR (WYE-DELTA START)	B1/B6
STR	MOTOR START CONTACTOR (WYE-DELTA START)	B1/B6
TRU	WYE-DELTA MOTOR RUN RELAY (WYE-DELTA START)	A1
TRUP	WYE-DELTA MOTOR RUN TIMER (WYE-DELTA START)	A4
UL	UP LEVEL RELAY (on Printed Circuit board)	A1
VR	VOLTAGE RELAY (OPTIONAL) (on Printed Circuit board)	A1

7. Parts List

<u>ITEM</u>	<u>DESCRIPTION</u>	<u>MANUFACTURER</u>	<u>PART NO</u>
<u>RELAYS</u>			
A1	4PDT, 120VAC, PLUG-IN RELAY	P&B	KH 6479
A2	4PDT, 110VDC, PLUG-IN RELAY	P&B	KH 6392
A3	SURFACE MOUNT RELAY SOCKET	CUSTOM CONNECTOR	MT-14-PC
A4	TIMER, 0-102.3 SECONDS	SSAC	TDUL-3001A
A5	3PDT, 120VAC, PLUG-IN RELAY	P&B	KUP-14A35
<u>CONTACTORS, STARTERS, OVERLOAD</u>			
B1	Y-D REVERSING CONTACTOR (NEMA)	FURNAS	43__P32AAE
B2	3 POLE THERMAL OVERLOAD (NEMA)	FURNAS	48__C31AA4
B3	ACROSS-THE-LINE STARTER (NEMA)	FURNAS	14__P32AA
B4	HEATERS FOR 3 POLE OVERLOAD (NEMA)	FURNAS	H__
B5	Y-D REVERSING CONTACTOR (IEC)	TELEMECHANIQUE	(SEE
B6	ACROSS-THE-LINE STARTER (IEC)	TELEMECHANIQUE	STARTER
B7	3 POLE OVERLOAD (IEC)	TELEMECHANIQUE	SHEET)
<u>TRANSFORMERS, FUSES, TERMINALS</u>			
C1	460-230-208/230-115, 600VA	RAM	C-4797
C2	250V INSTANTANEOUS FUSE	LITTELFUSE	TYPE BLF
C3	250V FUSEHOLDER	CURTIS	PW1F
C4	TRACK FOR 250V FUSEHOLDERS	CURTIS	SW192

<u>ITEM</u>	<u>DESCRIPTION</u>	<u>MANUFACTURER</u>	<u>PART NO</u>
C5	3 POLE TERMINAL, 600V, 50AMP	CURTIS	3PSWT
C6	MOUNTING TRACK FOR TERMINALS	CURTIS	SW192
<u>MICRO-PROCESSOR</u>			
D1	MICROPROCESSOR CPU BOARD	V.C.	MH2000-CPU
D2	8-IN/8-OUTPUT MODULE	V.C.	MH2000-8IO
D3	24-IN/24-OUTPUT MODULE	V.C.	MH2000-24IO
D4	KEYPAD	V.C.	MH2000-KEYPAD
D4	LCD SCREEN	V.C.	MH2000-LCD
<u>MISCELLANEOUS COMPONENTS AND HARDWARE</u>			
E1	PRINTED CIRCUIT BOARD	V.C.	MH-3
E2	PHASE MONITOR BOARD	V.C.	PMB
E3	1"W X 2"H DUCT	TAYLOR	91020
E4	1"W X 3"H DUCT	TAYLOR	91030
E5	1"W DUCT COVER	TAYLOR	99010
E6	1"W DUCT MOUNTING CLIPS	TAYLOR	08010
E7	CONTROLLER ENCLOSURE	PIEDMONT	(SIZE)
E8	STARTER ENCLOSURE	PIEDMONT	(SIZE)

All parts are commercially available from the manufacturer, or from Virginia Controls Inc. (ask for the Parts Department). Parts are subject to change without notice. Consult Virginia Controls, Inc. for current pricing information. Non-standard material is identified on the schematic.

8.1 Monitor Mode

When the controller is powered up, or the Reset Button is pushed, the micro-processor will be in the Monitor Mode. In this mode the micro-processor will allow the Inputs and Outputs to operate properly, and the elevator to run. (The only other mode is the Setup Mode, as described below. In the Setup Mode the elevator is shutdown, and all outputs are turned off.)

Several diagnostic displays are available in the Monitor Mode, and each is accessed from the Monitor Main Menu, by scrolling through the selections until the desired item is located, and "ENT" is pressed.

8.1.1 Monitor Main Menu

When the controller is powered up, the system will be in the Monitor Main Menu. The display will be blank until a key is pressed. It will then show the first item in the Main Monitor Menu ("Show I/O Status").

Pressing "Nxt" or "Prv" will scroll through the available items in the Main Monitor Menu. To select a display, press "Nxt" or "Prv" to show the desired item, then press "Ent" to enter the desired monitor mode.

The selections available in the Monitor Main Menu are:

1. Show I/O Status
2. Show Internal Memory
3. Go to Set-Up Mode

Additionally a "Banner Mode" is available. This is accessed by pressing "Esc" from the Main Monitor Menu. The "Banner Mode" displays a banner that consists of "VaControls" and the base program name on the top line, and a code on the bottom line that shows the Virginia Controls Job Number; the program revision number (initially "1"); and the date code for the program, in the form MMDDYY. The scan time in the "Banner Mode" is faster than the other Monitor modes, since the LCD display is not serviced. The controller is put in the "Banner Mode" when the "Set-up Mode" is exited.

8.1.2 Show I/O Status

The "Show I/O Status" display allows the screen to display the status of the Inputs and Outputs in groups of 16. This display is useful for checking the integrity of the I/O boards and the communications between the CPU board and the I/O boards. The display should agree with the corresponding LEDs on the I/O boards.

The names and numbers shown on the top line of the display correspond to the addresses on the I/O board as set by the jumper plugs on each I/O board. The address jumper for the letter (A,B,C,D) determines the first letter of the address. The next number of the address is determined by the number jumper (on 8point I/O boards) or by the physical location (on 24point I/O boards). The top line will indicate the address currently being displayed, and whether inputs or outputs are being monitored.

The bottom line shows the status of the inputs or outputs currently being displayed, with each character corresponding to one of the inputs or outputs. The status will either be a "1" if the signal is on, or a "0" if the signal is off. The order of the bits corresponds to the order of the LEDs on the I/O board, that is, the far left bit corresponds to the lowest number being monitored.

INPUTS B10-27
0010000011011010

For example, if the top line reads "INPUTS B10-27" then the bottom far left bit shows the status of Input B10, and the far right bit shows the status of Input B27. In the example above, B12, B20, B21, B23, B24, B26 are all on.

8.1.2.1 Moving Around

Press "Nxt" or "Prv" to scroll through the I/O.

Press "Aux" to toggle between Inputs and Outputs.

Press "Esc" to return to the Monitor Main Menu.

The keys 0-9, ".", and "Ent" are not used in this mode.

8.1.3 Show Internal Memory

The "Show Internal Memory" screen (abbreviated to "Show Int. Memory" on the LCD display) shows the contents of the internal memory. This can be used to check the status of internal registers, to show the operation of the system.

When this display is selected, the display will show five numbers on each row. The left number in each row is a 4-digit hexadecimal number showing the memory address of the number immediately to its right. The memory is 8-

bit, so the 4 pairs of numbers on the right show the contents of each of four consecutive memory addresses in hexadecimal format.

1024	FF	00	2D	14
1028	00	FF	00	00

For example, if the display reads "1024 FF 00 2D 14" then the contents of address "1024" is "FF", the contents of address "1025" is "00", the contents of address "1026" is "2D", and the contents of address "1027" is "14" (with each value being shown in hexadecimal). The next line shows the next four addresses.

NOTE: For addresses that show an ON or OFF condition, "00" corresponds to OFF, and "FF" corresponds to ON.

8.1.3.1 Moving Around

- Press "Nxt" to increase the addresses being displayed by 4.
- Press "Prv" to decrease the addresses being displayed by 4.
- Press "3" to increase the addresses being displayed by 10(Hex).
- Press "6" to decrease the addresses being displayed by 10(Hex).
- Press "2" to increase the addresses being displayed by 100(Hex).
- Press "5" to decrease the addresses being displayed by 100(Hex).
- Press "1" to increase the addresses being displayed by 1000(Hex).
- Press "4" to decrease the addresses being displayed by 1000(Hex).
- Press "Aux" to increase the addresses being shown by 1.
- Press "Esc" to return to the Monitor Main Menu.

8.1.3.2 LED Description in "Show Internal Memory" Mode

The LEDs L1, L2, L3, L4 change operation in the Monitor Mode. They now show the status of the top 4 words being displayed. (Specifically, L1 shows the status of the 4th bit of the top left word being displayed; L2 shows the status of the 3rd bit of the 2nd left word being displayed; L3 shows the status of the 2nd bit of the 3rd top left word being displayed; and L4 shows the status of the 1st bit of the 4th top left word being displayed).

This allows the LEDs to show rapid changes in the status of internal memory, that the LCD display would not be quick enough to respond to.

8.1.3.3 Changing Data in the "Show Internal Memory" Mode

Warning: This can cause unexpected and or dangerous results. Be very careful when using this feature.

When monitoring the Internal Memory on-line, and if the password has been entered, you can change the value of the address in the top left location by pressing the "." (period) key, then one of the following keys:

- | | |
|--------------------------------------|--------------------------------------|
| "1" will increase the value by 40H | "4" will decrease the value by 40H |
| "2" will increase the value by 10H | "5" will decrease the value by 10H |
| "3" will increase the value by 04H | "6" will decrease the value by 04H |
| "Nxt" will increase the value by 01H | "Prv" will decrease the value by 01H |
| "7","AUX" will not do anything. | "8" will invert the value |
| "9" will set the value to FFH | "0" will set the value to 00H |

For example, to change the Current Time Code, which is in address 005F, do the following steps.

1. Press ESC to go to the Banner Screen.
2. Press 7 to leave the Banner screen with the password enabled.
3. Press NXT to scroll to the Show Int Memory menu item then press ENT.
4. Scroll to the desired address (in this example 005F). Refer to the list in section 8.1.3.1 for the keys to scroll in different increments. Note that pressing AUX will scroll by one address at a time.
5. Verify that the top left value shows the desired address (in this example it should be 005F)
6. Press the period key (.)
7. Press the appropriate button as described at the top of this section 8.1.3.3 to change the value of this address.
8. Repeat the steps 6 and 7 until the value is at the desired new value.

- To reset the password, so that changes cannot accidentally be made, press ESC twice, to go to the Banner Screen, then press ENT to leave the Banner Screen.

8.1.4 Go To Set-Up Mode

This selection allows the controller to be taken out of normal operation, and put in the Set-up Mode, so that features and settings may be changed.

When "Ent" is pressed at this selection, a warning screen will be displayed, indicating that the controller will stop.

If "Ent" is pressed again, then the controller will turn off all outputs and the controller will go into the Set-up Mode. A banner will be displayed for 1 second indicating the Set-up Mode has been entered. The first selection of the Set-up Menu will then be displayed.

If any other key is pressed from the Warning screen, the controller will return to the Monitor Mode, and the controller will continue operating as normal.

LED L5 will stop flashing in the Set-up Mode.

8.1.5 Effect of Diagnostic Modes on Scan Time

The micro-processor scan time is very fast, with each scan taking about 10 milliseconds. Servicing the LCD display is one of the more time consuming tasks that the micro-processor does, so when the LCD display needs to be updated regularly, the micro-processor must slow down to allow it to accept the data. Consequently, the scan time is slower when in the "Show I/O Status" and "Show Internal Memory" Modes, than in the Main Monitor Menu mode. The car will still operate normally, but it is recommended that the car be left with the banner being displayed, since this bypasses the LCD display, and provides the quickest scan time.

8.2 Set-Up Mode

8.2.1 How to Enter Set-Up Mode

In the Main Monitor Menu, press "Nxt" until the selection "Go To Setup Menu" is shown, then press "Ent".

Press "Ent" when the "Warning" message is displayed.

WARNING: The elevator will stop immediately and be completely shut down, as all outputs will be turned off when the Set-up Mode is entered.

The following Menu items are available in the Set-up Mode:

- Reset Settings.
- Change Features.
- Change Settings.
- Show Hex Memory.
- Enter Password.
- Test I/O Boards.

Press the "Nxt" or "Prv" keys to move through the Set-up Menu to the desired item, then press "Ent" to select the menu item.

8.2.2 How to Exit Set-Up Mode

Press "Esc" from the Set-up Menu to return to the Monitor Mode. The controller will start running again, and will be in the Banner Mode. LED L5 will start flashing again, indicating the CPU is scanning.

Note: It may be necessary to press "Esc" to exit a sub-menu and return to the Set-up Menu, before going back to the Monitor Menu.

8.2.3 Reset Settings

This selection allows all settings and features to be reset to the factory values that are stored in the EPROM. This should be done on initial installation, and is recommended if the car has been left with power off for several days.

Press "Ent" to reset all settings and features to the values programmed from the factory.

Press "Nxt" or "Prv" to move to another item in the Set-up Menu.

Press "Esc" to return to the Monitor Menu.

NOTE: An internal memory check is done on each power up. So if a corrupted memory is detected, a factory reset will be done automatically.

A factory reset can also be done without the keypad as follows:

1. Turn off the power
2. Turn the Inspection Switch to "Inspection" (or remove the field wire from terminal 23)
3. Jump terminals 1 to 21 and 22 (Up and Down Level Sw Inputs)
4. Turn the power back on for 10 seconds. Inputs A11 and A12 should both be ON, and Input A13 should be OFF.
5. Turn off the power
6. Remove all jumpers and put the car back on normal operation.

8.2.4 Change Settings

Use this selection to change the settings described below. Each setting contains a value from 0 to 255. As you scroll through the settings, the current value will be displayed. A new value may be entered over the old value, as desired.

NOTE: The Password "911" may be required to gain access to this menu selection.

Press "Nxt" to go to the next setting, without changing the current setting.

Press "Prv" to go to the previous setting, without changing the current setting.

Press a numeric key (0-9) to enter a new value. (The decimal point key "." is not used)

Press "Ent" after entering a new value to load the new value into memory. (The new value will be displayed for 1 second, then the display will advance to the next setting) If "Nxt", "Prv" or "Esc" is pressed after entering a new value, the new value will NOT be stored in memory. You can double check the value by pressing "Prv".

Press "Esc" to go back to the Setup Menu.

If an incorrect value is entered, press "Esc" to clear the value before it is accepted, then enter the correct value; or press "Nxt" or "Prv" to move to the next setting. If the value was already entered, by pressing "Ent", then press "Prv" to return to the incorrect setting, enter the proper setting, and press "Ent".

8.2.5 Description of Settings

To see the actual settings available on a particular job, see the MH2000 Settings sheet in the schematic. The following Settings are standard (NOTE: a value of 0 to 255 can be entered unless otherwise stated):

- **Number of Landings** - (Display shows "NUMBER OF LDGS") This is the number of landings that the controller can serve, and is a value between 2 and 8. This number should not normally be changed, since the inputs and outputs have to be assigned for the correct number of landings. If the controller is set up to serve future landings, then this value can be used to temporarily cut off future upper landings. This value also determines which floor the controller will reset to when a top landing reset is initiated with a pulsing selector.
- **Main Fire Landing** - (Display shows "MAIN FIRE LDG") This is the number corresponding to the Main Fire Landing, and is a number between 1 and 8. The value set is based on the bottom floor being "1", the 2nd floor is "2" etc., even if this does not match the building designations.

CAUTION: If it is set to a value greater than the number of landings served, the car will go to the top landing, but it will not open its doors.

- **Alternate Fire Landing** - (Display shows "ALT. FIRE LDG") This is the number corresponding to the Alternate Fire Landing, and is a number between 1 and 8. The value set is based on the bottom floor being "1", the 2nd floor is "2" etc., even if this does not match the building designations.

CAUTION: If it is set to a value greater than the number of landings served, the car will go to the top landing, but it will not open its doors.

- **Home Landing** (SIMPLEX ONLY) - (Display shows "HOME LANDING") This is the home landing for a simplex car. The car can be selected to home to this landing, if desired. This value can be set to any valid landing, as determined by the number of landings setting.
- **Dispatch Landing** (DUPLEX ONLY) - (Display shows "DISPATCH LDG") This is the dispatch landing for duplex systems. One car will always home here.

- **Upper Home Landing (DUPLEX ONLY)** - (Display shows "UPPER HOME LDG") This is the home landing for the free car in a duplex system. The free car can be selected to home to this landing, if desired. This value should be set to be inside the upper zone, as determined by the Low Zone assignments shown later in the features settings.
- **Front Door Code** - (Display shows "FRONT DOOR CODE") This value determines the location of any front calls with front and rear systems. This setting may be broken out as individual features per floor, as described later. Refer to the schematic sheet "MH2000 SETTINGS" for information on setting this value, and whether it is used. The chart shown there indicates the value (in the "Val" column) that will enable the front door at each floor. Add up the value for the desired floors to determine the correct value for this setting. With non-selective doors (no walk-throughs) then turning off a front opening automatically enables the rear opening at that floor.
- **Rear Door Code** - (Display shows "REAR DOOR CODE") This value determines the location of any rear calls with selective-open doors (walk-throughs). Refer to the schematic sheet "MH2000 SETTINGS" for information on setting this value. The chart shown there indicates the value (in the "Val" column) that will enable the rear door at each floor. Add up the value for the desired floors to determine the correct value for this setting.
- **Low Zone Code** - (Display shows "LOW ZONE CODE") This value determines which floors are in the Low Zone. The floors will normally be served by the Lobby car, other floors will normally be served by the Free car. Refer to the schematic sheet "MH2000 SETTINGS" for information on setting this value. The chart shown there indicates the value (in the "Val" column) that will select a floor for the Low Zone. Add up the value for the desired floors to determine the correct value for this setting.
- **Features Code #1** - (Display shows "FEATURES CODE #1") This value determines which of 8 different features are enabled. Refer to the schematic sheet "MH2000 SETTINGS" for information on setting this value. The chart shown there indicates the value (in the "Val" column) that will select each feature. Add up the value for the desired features to determine the correct value for this setting.
- **Features Code #2** - (Display shows "FEATURES CODE #2") This value determines which of 8 different features are enabled. Refer to the schematic sheet "MH2000 SETTINGS" for information on setting this value. The chart shown there indicates the value (in the "Val" column) that will select each feature. Add up the value for the desired features to determine the correct value for this setting.
- **Features Code #3** - (Display shows "FEATURES CODE #3") This value determines which of 8 different features are enabled. Refer to the schematic sheet "MH2000 SETTINGS" for information on setting this value. The chart shown there indicates the value (in the "Val" column) that will select each feature. Add up the value for the desired features to determine the correct value for this setting.
- **Custom Value #1** - (Display shows "CUSTOM VALUE #1") This is a reserved value that is not assigned, but may be assigned a function for a specific job. Refer to the schematic sheet "MH2000 SETTINGS" for information on setting this value, and if it is used on a particular job.
- **Custom Value #2** - (Display shows "CUSTOM VALUE #2") This is a reserved value that is not assigned, but may be assigned a function for a specific job. Refer to the schematic sheet "MH2000 SETTINGS" for information on setting this value, and if it is used on a particular job.
- **Custom Value #3** - (Display shows "CUSTOM VALUE #3") This is a reserved value that is not assigned, but may be assigned a function for a specific job. Refer to the schematic sheet "MH2000 SETTINGS" for information on setting this value, and if it is used on a particular job.
- **Door Time, Hall** (in tenths of a second) - (Display shows "DOOR TIME, HALL") This is the time in tenths of a second, that the doors will remain open, after they have opened fully, when the car has stopped in response to a hall call. After this time, the doors will start to close. NOTE: If a car call is entered while the doors are open, the door time will be reduced to the "Door Time, Car" setting. This setting is normally 50 tenths of a second (that is 5 seconds).
- **Door Time, Car** (in tenths of a second) - (Display shows "DOOR TIME, CAR") This is the time in tenths of a second, that the doors will remain open, after they have opened fully, when the car has stopped in response to a car call only. After this time, the doors will start to close. NOTE: If a car call is entered while the doors are open, the door time will be reduced to the "Door Time, Short" setting. This setting is normally 20 tenths of a second (that is 2 seconds).
- **Door Time, Short** (in tenths of a second) - (Display shows "DOOR TIME, SHORT") This is the time in tenths of a second, that the doors will remain open, after they have opened fully, when the doors have reopened in response to a Door Open Button/Safety edge/Electric Eye/Infra-red Curtain, and no hall call is entered. After this time, the doors will start to close. The normal setting is 10 tenths of a second (that is 1 second)
- **Leveling Cutout Time** (in tenths of a second) - (Display shows "LEVELING LOCKOUT") This is the time in tenths of a second that the leveling switches are cut out after the start of a floor to floor run. It allows the

external relays to energize and lock out the leveling switches externally. The normal setting is 20 tenths of a second (or 2 seconds)

- **Back Call Delay** (DUPLEX ONLY) (in tenths of a second) - (Display shows "BACK CALL DELAY") This is the time in tenths of a second that the back call signal will be delayed before letting the other car respond to calls behind this car. The normal setting is 10, for a time of 1 second.
- **Custom Time #1.1** (in tenths of a second) - (Display shows "CUSTOM TIME #1.1") This is a reserved value that is not assigned, but may be assigned a function for a specific job.
- **Custom Time #1.2** (in tenths of a second) - (Display shows "CUSTOM TIME #1.2") See Custom Time # 1.1
- **Custom Time #1.3** (in tenths of a second) - (Display shows "CUSTOM TIME #1.3") See Custom Time # 1.1
- **Shutdown Time** (in seconds) - (Display shows "SHUTDOWN TIME") If the car runs up without passing a floor for this time, then shutdown will be initiated. The car will stop, and run down to the bottom landing, and cycle its doors. It will then be shut down. The car can be returned to service by cycling the Inspection Switch, or the Main Line Disconnect Sw. The normal setting is 25 seconds.
- **Door Nudging Time** (in seconds) - (Display shows "NUDGING TIME") This is the time delay before initiating door close nudging, if that feature is provided. A call must be registered, and the car must be in automatic operation. The timer is reset when the doors get fully closed, or when the car starts a floor to floor run. The normal setting is 25 seconds.
- **Electric Eye Cutout Time** (in seconds) - (Display shows "EYE CUTOFF TIME") This is the time delay before cutting out the Electric Eye Input, after it has been continuously energized. It is reset when the car runs to the next floor. The normal setting is 20 seconds.
- **Homing Delay Time** (in seconds) - (Display shows "HOMING DELAY") This is the delay before homing a car to the home landing, after it has answered all calls, and is sitting with its doors closed. The normal setting is 10 seconds.
- **Car Stuck Time** (in seconds) - (Display shows "CAR STUCK TIME") This is the time delay before calls at the same landing as the car are disabled, so that the car can answer other registered calls. This operates as a stuck button timer. The normal setting is 15 seconds.
- **Door Stalled Time** (in seconds) - (Display shows "DOOR STUCK TIME") This is the time delay before stopping a door open or close cycle. The normal setting is 10 seconds
- **Door Stalled Reset Time** (in seconds) - (Display shows "DOOR RESET TIME") This is the time that the doors are held open after failing to close properly, before retrying to close. The normal setting is 10 seconds.
- **Delay Before Canceling Independent Service on Fire Service** - (Display shows "KILL IDS ON FIRE") This is the time delay before Independent Service is cut out, when Fire Service Phase 1 is initiated. This feature can be modified by the features described below that determine if and when Independent Service is cut out on Fire Service. The normal setting is 30 seconds.
- **Delay Before Closing the Doors on Fire Service** - (Display shows "DR CLOSE ON FIRE") This is the time delay before the doors close when Fire Service Phase 1 is initiated and the car has returned to the main landing. It is used with 2000 ANSI Fire Code if the car is also on shutdown. The normal setting is 10 seconds.
- **Call Help Time** (DUPLEX ONLY) (in seconds) - (Display shows "CALL HELP TIME") This is the amount of time a hall call can be registered before the other car not assigned this call will respond to the call. The normal setting is 30 seconds.
- **Non Interference Time** (SAPB ONLY) (in seconds) - (Display shows "NON INTERFERENCE") This is the time that the Hall Calls will be cut out after the car has stopped, and the doors have cycled before a Hall Call can be entered. The In Use Light will remain on during this time.
- **Custom Time #2.1** (in seconds) - (Display shows "CUSTOM TIME #2.1") This is a reserved value that is not assigned, but may be assigned a function for a specific job.
- **Custom Time #2.2** (in seconds) - (Display shows "CUSTOM TIME #2.2") See Custom Time # 2.1
- **Custom Time #2.3** (in seconds) - (Display shows "CUSTOM TIME #2.3") See Custom Time # 2.1
- **Position Indicator Shut Off Time** (in tens of seconds) - (Display shows "PI SHUT OFF TIME") This is the time delay after the car finishes all calls before the Position Indicator outputs are turned off. If it is desired to keep the PI's on at all times, then set this value to 0.
- **Custom Time #3.1** (in tens of seconds) - (Display shows "CUSTOM TIME #3.1") This is a reserved value that is not assigned, but may be assigned a function for a specific job.
- **Custom Time #3.2** (in tens of seconds) - (Display shows "CUSTOM TIME #3.2") See Custom Time # 3.1

- **Custom Time #3.3** (in tens of seconds) - (Display shows "CUSTOM TIME #3.3") See Custom Time # 3.1.
- **Communication Delay (DUPLEX ONLY)** - (Display shows "COMMUNIC DELAY") This is a value that sets the communication rate. It should not be changed from a value of 253 without consulting with Virginia Controls.
- **BAUD Rate Code (DUPLEX ONLY)** - (Display shows "BAUD RATE CODE") This is a value that sets the communication BAUD rate on duplex systems. Both cars must have the same setting, and this setting should not be changed from 48 without consulting with Virginia Controls. The Communication Rate and BAUD Rate on Duplex controllers are not adjustable.

Some installations require specific settings or features that are not included in the standard program. In this case, a separate sheet (or sheets) will be provided that describe the operation of these settings or features, and what the factory default settings are. All settings, and their default values are shown on the sheet "MH2000 SETTINGS" in the schematic. Refer to that sheet for the particular settings for each controller.

8.2.6 Change Features

Use this selection to change the features described below. Each feature is either on (value of 255) or off (value of 0). As you scroll through the features, the feature will be shown as enabled (ON) or disabled (off). The feature may be changed by pressing "Aux" to select the desired operation (on/enabled or off/disabled), then press "Ent" to store the value.

NOTE: The Password "911" may be required to gain access to this menu selection.

Press "Nxt" to go to the next feature, without changing the current feature.

Press "Prv" to go to the previous feature, without changing the current feature.

Press "Aux" to toggle the feature between on/enabled or off/disabled.

(The 0-9 and decimal point keys "." are not used)

Press "Ent" after selecting a new value to load the new value into memory. (The new feature will be displayed for 1 second, then the display will advance to the next feature) If "Nxt", "Prv" or "Esc" is pressed after entering a new value, the new value will NOT be stored in memory.

Press "Esc" to go back to the Setup Menu.

8.2.7 Description of Features

Several of the features described below are included in the settings in the Feature Codes. Refer to the sheet "MH2000 SETTINGS" for a listing of the specific settings and factory default values used on any particular job.

The following features are standard (All features are normally off/disabled, unless otherwise specified):

- **No Shortened Door Time** - (Display shows "NO SHORTDOORTIME") Normally the door time will be shortened by the Door Open Button/Safety Edge/Electric Eye/Infra-red Curtain. Enable this feature to prevent these devices from shortening the door time. This is normally required in nursing homes, where the passengers need more time to enter the car. The Door Close Button will still shorten the door time.
- **Timed Electric Eye Cutout** - (Display shows "TIMED EYE CUTOUT") Enable this feature to allow the Electric Eye input to be disabled after the preset time (see the setting above for the delay before cutting out the Electric Eye). This feature is often provided in the Electric Eye unit itself.
- **Door Nudging** - (Display shows "DOOR NUDGING") Enable this feature to activate door close nudging. Nudging will be initiated if a call is registered and the doors have been prevented from closing for the preset Door Nudging time. The Electric Eye will be disabled, the Nudging Buzzer will come on, and the Nudging Output will come on if the Electric Eye input is energized. This means the door will only close at slow speed if the Electric Eye is blocked. Note: Door Nudging operation requires an optional Nudging Buzzer output and Reduced Speed Door Closing output.
- **One Stroke Down Lanterns** - (Display shows "1 STROKE DN LANT") The lanterns are normally provided with two strokes for the down direction. Enable this feature to provide only one stroke for the down direction.
- **Slow Speed on Inspection** - (Display shows "SLOW ON INSPECT") Enable this feature to run slow speed on Inspection. This is normally required if the car speed is 150fpm or above.
- **Proximity Detector** - (Display shows "PROXIMITY DETECT") Enable this feature if a Proximity Detector (such as an infra-red curtain) is used. Enabling this feature will cause the Safety Edge input to be disabled on Fire Service, and the Door Nudging feature to be initiated while the doors are closing on Fire Service. The Proximity Detector may be connected to the Safety Edge Input or the Electric Eye Input, as desired. (The Electric Eye

Input is subject to the Timed Electric Eye Cutout and Nudging, whereas the Safety Edge Input is not.) Note: Door Nudging operation requires an optional Nudging Buzzer output and Reduced Speed Door Closing output.

- **Short Floor** - (Display shows "SHORT FLOOR") The Short Floor selection applies to installations with Floor Switches or Pulsing Switches where the floor height is less than twice the slowdown distance, but more than the slowdown distance plus the leveling zone. If Floor Switches are used, then the Short Floor Setting should be enabled if the Floor Switches overlap at any floor. If Pulsing Switches are used, then the Short Floor Setting should be enabled if an Up target is BELOW a Down target at any floor. With Floor Switches or a Pulsing Selector, if the slowdown overlaps the leveling zone of the adjacent floor, then special short floor circuitry is required, and this setting will not normally apply. (Check for specific instructions for the job.)
- **Enable Homing** - (Display shows "HOME TO MAIN LDG" or "ENABLE HOMING" on Simplex, or "HOME #2 TO MAIN" on Duplex) Enable this feature to enable the homing feature on a Simplex. This will cause the car to home to the Home Landing, when it has been idle for the adjustable Homing delay time. NOTE: On a Duplex, one car will always home to the Dispatch Main Landing, and, if this feature is set, then the FREE car will also home to the Dispatch Main Landing.
- **Enable Free Car Homing (Duplex Only)** - (Display shows "HOME TO HI ZONE") Enable this feature to home the free car to the Upper Home Landing. If this is not set, then the car will remain where it last stopped.
- **Independent Service/Fire Service Override Selection 1** - (Display shows "IMMED KILL IDS") If this feature is enabled, Independent Service will be disabled immediately on Fire Service.
- **Fire Service Main Landing Opening (Simplex Only)** - (Display shows "EFS MAIN = REAR") If this feature is enabled, the Fire Service Main Landing will use the rear door if there are selective doors at that landing.
- **Fire Service Alternate Landing Opening (Simplex Only)** - (Display shows "EFS ALT. = REAR") If this feature is enabled, the Fire Service Alternate Landing will use the rear door if there are selective doors at that landing.
- **Disable Fire Service** - (Display shows "NO FIRE SERVICE") If this feature is enabled, then Fire Service Phase 1 and 2 will be disabled.
- **Fire Service NY City code** - (Display shows "FIRE CODE - NY") Enable this feature to select Fire Service Operation for New York City code.
- **Fire Service Chicago 2000 Code** - (Display shows "FIRECODE-CHICAGO") Enable this feature to select Fire Service Operation for year 2000 Chicago code.
- **Fire Service ANSI 2000 Code** - (Display shows "FIRE CODE -CALIF") Enable this feature to select Fire Service Operation for California code.
- **No Run on BORIS and Fire Service** - (Display shows "NO RUN=EFS+BORIS") With this feature set, the car will not lower on BORIS if the car is on Fire Service. If the feature is NOT set, then the car will automatically lower if it can, even if the car is on Fire Service. If the car is on Inspection, the car may be run down, but not up. This feature requires BORIS circuitry to be installed on the controller. The setting of this feature will not affect the operation of the controller if BORIS is not provided. This feature replaces the previous feature (No Boris Defeat), except it is the opposite in operation.
- **Run Shutdown** – (Display shows "NO RUN=EFS+SHTDN") With this feature set, the car will not run down on shutdown (low oil, Reverse Phase, Emergency Power, etc.) if the car is on Fire Service and if the car is already below the Fire Service Return Landing. If this feature is NOT set, then the car will run down and it will stop at the Fire Service Return Landing (if the "Stop at Main Ldg" feature is set) or the bottom landing. If the car is above the Fire Service Return Landing, it will run down to the Fire Service Return Landing.
- **Stop at Main Ldg** – (Display shows "STOP MF ON SHTDN") With this feature set, the car will stop at the Main Landing when the car is on shutdown (low oil, Reverse Phase, Emergency Power, etc.). If this feature is NOT set, then the car will stop at the bottom landing.
- **Enable CKO on Independent Service** - (Display shows "ENABLE CKO+INDEP") This feature will enable the CKO output if the car is on Independent Service. This is used with Car Call Cutout Switches if it is desired to override the cutout switches on Independent Service
- **Enable Front Opening at 1st Landing** - (Display shows "FRONT DOOR AT 1") This feature is enabled if there is a front opening at this landing, or disabled if there is no front opening at this landing.
- **Enable Front Opening at 2nd Landing** - (Display shows "FRONT DOOR AT 2") This feature is enabled if there is a front opening at this landing, or disabled if there is no front opening at this landing.
- **Enable Front Opening at 3rd Landing** - (Display shows "FRONT DOOR AT 3") This feature is enabled if there is a front opening at this landing, or disabled if there is no front opening at this landing.

- **Enable Front Opening at 4th Landing** - (Display shows "FRONT DOOR AT 4") This feature is enabled if there is a front opening at this landing, or disabled if there is no front opening at this landing.
- **Enable Front Opening at 5th Landing** - (Display shows "FRONT DOOR AT 5") This feature is enabled if there is a front opening at this landing, or disabled if there is no front opening at this landing.
- **Enable Front Opening at 6th Landing** - (Display shows "FRONT DOOR AT 6") This feature is enabled if there is a front opening at this landing, or disabled if there is no front opening at this landing.
- **Enable Front Opening at 7th Landing** - (Display shows "FRONT DOOR AT 7") This feature is enabled if there is a front opening at this landing, or disabled if there is no front opening at this landing.
- **Enable Front Opening at 8th Landing** - (Display shows "FRONT DOOR AT 8") This feature is enabled if there is a front opening at this landing, or disabled if there is no front opening at this landing.
- **Custom Feature #1** - (Display shows "CUSTOM FEATURE 1") This feature does not have a predefined purpose, but may be used for a specific function as required on a specific job. See the schematic to determine if this feature is used.
- **Custom Feature #2** - (Display shows "CUSTOM FEATURE 2") See Custom Feature # 1 above.
- **Custom Feature #3** - (Display shows "CUSTOM FEATURE 3") See Custom Feature # 1 above.
- **Custom Feature #4** - (Display shows "CUSTOM FEATURE 4") See Custom Feature # 1 above.
- **Custom Feature #5** - (Display shows "CUSTOM FEATURE 5") See Custom Feature # 1 above.

The following features are included as part of the Bit Features. See the MH2000 Settings sheet in the schematic to see where each feature is located. To turn an individual feature on or off, determine which Bit Feature should be changed, then add up the new value that gives the desired features, then enter that value as the new value for that Bit Feature.

- **Enable Rear Opening at 1st Landing** - This feature is enabled if there is a rear opening at this landing AND the elevator has selective openings. NOTE: This setting does not have to be enabled if the elevator is non-selective.
- **Enable Rear Opening at 2nd Landing** - This feature is enabled if there is a rear opening at this landing AND the elevator has selective openings.
- **Enable Rear Opening at 3rd Landing** - This feature is enabled if there is a rear opening at this landing AND the elevator has selective openings.
- **Enable Rear Opening at 4th Landing** - This feature is enabled if there is a rear opening at this landing AND the elevator has selective openings.
- **Enable Rear Opening at 5th Landing** - This feature is enabled if there is a rear opening at this landing AND the elevator has selective openings.
- **Enable Rear Opening at 6th Landing** - This feature is enabled if there is a rear opening at this landing AND the elevator has selective openings.
- **Enable Rear Opening at 7th Landing** - This feature is enabled if there is a rear opening at this landing AND the elevator has selective openings.
- **Enable Rear Opening at 8th Landing** - This feature is enabled if there is a rear opening at this landing AND the elevator has selective openings.
- **1st Landing is in the Lobby Zone (Duplex Only)** - (Display shows "LDG 1 IN LO ZONE") This feature is enabled if the 1st landing is in the Lobby Zone, or disabled if the 1st landing is in the Upper Zone. The Lobby Zone will be handled by the Lobby car, while the Upper Zone will be handled by the free car.
- **2nd Landing is in the Lobby Zone (Duplex Only)** - (Display shows "LDG 2 IN LO ZONE") This feature is enabled if the 2nd landing is in the Lobby Zone, or disabled if the 2nd landing is in the Upper Zone.
- **3rd Landing is in the Lobby Zone (Duplex Only)** - (Display shows "LDG 3 IN LO ZONE") This feature is enabled if the 3rd landing is in the Lobby Zone, or disabled if the 3rd landing is in the Upper Zone.
- **4th Landing is in the Lobby Zone (Duplex Only)** - (Display shows "LDG 4 IN LO ZONE") This feature is enabled if the 4th landing is in the Lobby Zone, or disabled if the 4th landing is in the Upper Zone.
- **5th Landing is in the Lobby Zone (Duplex Only)** - (Display shows "LDG 5 IN LO ZONE") This feature is enabled if the 5th landing is in the Lobby Zone, or disabled if the 5th landing is in the Upper Zone.
- **6th Landing is in the Lobby Zone (Duplex Only)** - (Display shows "LDG 6 IN LO ZONE") This feature is enabled if the 6th landing is in the Lobby Zone, or disabled if the 6th landing is in the Upper Zone.

- **7th Landing is in the Lobby Zone** (Duplex Only) - (Display shows "LDG 7 IN LO ZONE") This feature is enabled if the 7th landing is in the Lobby Zone, or disabled if the 7th landing is in the Upper Zone.
- **8th Landing is in the Lobby Zone** (Duplex Only) - (Display shows "LDG 8 IN LO ZONE") This feature is enabled if the 8th landing is in the Lobby Zone, or disabled if the 8th landing is in the Upper Zone.
- **Enable Pulsing Selector** - Enable this feature if a pulsing selector is used instead of floor switches.
- **Enable Call I/O Separate (4 Wire Calls)** - If the call buttons and lights are both connected to the call inputs and outputs, then this feature should be set to "disabled". If the call buttons are connected to the inputs and the call lights are connected to the call outputs and they are not jumped, then this feature is set to "enabled".
- **Enable Door Check Feature** - If the appropriate I/O is provided, and this feature is enabled, then the doors will be held open if the Car or Hall Door Contacts Input is energized, but the doors are still open. This feature should be disabled if not required, or if the appropriate I/O is not provided.
- **Attendant Lights = Direction Not Demand** (Simplex Only) - If this feature is disabled, the Attendant direction lights will show whether calls in each direction are registered, thus both direction indicator lights may be on. If this feature is enabled, the Attendant direction lights will show which direction is selected, thus only one direction indicator light will be on at a time.
- **Buzzer on Independent AND Med Emerg** (Simplex Only) - If this feature is disabled then the Medical Emergency Buzzer output will come on while the car is returning to the Medical Emergency Landing. If this feature is enabled, then the Medical Emergency Buzzer output will come on when the car is on Independent Service and a hall Medical Emergency Key Switch is turned on.
- **Use TLU/TLD as Hall Lantern outputs** - Enable this feature to use the Car Lantern outputs as Hall Lantern Outputs. The signal will now come on when the car starts to slow down for a call, rather than when the doors start to open.
- **Use Chicago pre-1999 Fire Code** - Enable this feature to select Fire Service Operation for 1999 Chicago code.
- **2 Inputs for Chicago Hall Fire Service** - Enable this feature if Chicago Code Fire Service is required, and only two inputs are used for the Smoke Sensors and Hall Fire Switch. If four inputs are used, then this setting should be disabled.
- **Use pre-2000 Canadian Fire Code** - Enable this feature to select Fire Service Operation for Canadian code.
- **No Timed Kill of Independent on Fire Service** - If this feature is enabled, Independent Service will not be disabled after a preset time, but only when the doors have been closed manually.
- **Never kill Indep on Fire Service** - If this feature is enabled, Independent Service is not overridden by Fire Service. The Independent Service Switch must be turned off to allow the car to respond to Fire Service.
- **Disable Shunt on Fire Service Phase 2** - Enable this feature to disable the Shunt Trip output if the car is on Fire Service Phase 2, if required by the applicable codes.
- **Enable Shunt on Inspection** - Enable this feature to enable the Shunt Trip output if the car is on Inspection, if required by the applicable codes.
- **Enable Redundancy Fault Checking** – If the appropriate Inputs are provided, enable this feature to enable Redundancy Fault checking.
- **Enable Bldg Fire Sw for 2000 Fire Code** - If t–e appropriate Input is provided, enable this feature to enable the remote Building Fire Sw allowed in 2000 Fire Code.
- **Disable ECReturn Latch on 2000 Fire Code** - Enable this feature to allow the Fire Service Phase 2 Return feature to be cancelled while the car is returning to the designated Fire Landing if the car Fire Switch is turned to the off position. With this feature disabled, the car will continue to return to the designated landing.
- **Always Enable DOB at Front Openings** – (Jobs with Front and Rear Selective Openings only) With this feature disabled, the Door Open Button, Safety Edge and Electric Eye (or Infra Red Curtain) are disabled at floors with both front AND rear openings, unless the front doors were opened by a car or hall call. This allows a measure of security, ensuring that a passenger cannot register a call for the rear opening, then exit the front opening using the Door Open Button. Enable this feature to allow the Door Open Button to reopen the front doors no matter which doors were opened at this landing.
- **Always Enable DOB at Rear Openings** – (Jobs with Front and Rear Selective Openings only) With this feature disabled, the Door Open Button, Safety Edge and Electric Eye (or Infra Red Curtain) are disabled at floors with both front AND rear openings, unless the rear doors were opened by a car or hall call. This allows a measure of security, ensuring that a passenger cannot register a call for the front opening, then exit the rear opening using the Door Open Button. Enable this feature to allow the Door Open Button to reopen the rear doors no matter which doors were opened at this landing.

- **Fire Service Shunt Operation** (SAPB Only) - (Display shows "SHUNT ON w/ DOL") This feature is enabled to allow the Fire Service Shunt Output to come on when the doors have opened. With the feature disabled, the Shunt output will come on when the car stops at the fire return ldg. This is used with SAPB controllers only.
- **Stop Sw Bypass Selection** (SAPB Only) - (Display shows "ESB OFF with DOL") This feature is enabled to allow the ESB output to drop when the doors get fully open. This is used with SAPB controllers only.
- **Single Button Collective Operation** (SAPB Only) - (Display shows "On=SBC, Off=SAPB") This feature is enabled to select Single Button Collective Operation. This is used with SAPB controllers only.
- **Freight Door Automatic Close Enable** (SAPB Only) - (Display shows "AUTO DOOR CLOSE") This feature is enabled to activate the Automatic Door Close outputs for freight doors on SAPB controllers.
- **Freight Door Automatic Close from Hall** (SAPB Only) - (Display shows "HALL AUTO CLOSE") This feature is enabled to activate the Automatic Door Close operation from Hall Call Buttons, on SAPB controllers.

Some installations require specific settings or features that are not included in the standard program. In this case, a separate sheet (or sheets) will be provided that describe the operation of these settings or features, and what the factory default settings are.

8.2.8 Show Hex Memory

This selection is the same as the Show Internal Memory in the Monitor Menu section. The screen shows the contents of the internal memory. This can be used to check the status of internal registers, to show the operation of the system.

When this display is selected, the display will show five numbers on each row. The left number in each row is a 4-digit hexadecimal number showing the memory address of the number immediately to its right. The memory is 8-bit, so the 4 pairs of numbers on the right show the contents of each of four consecutive memory addresses in hexadecimal format.

For example, if the display reads "102C FF 00 2D 14" then the contents of address "102C" is "FF", the contents of address "102D" is "00", the contents of address "102E" is "2D", and the contents of address "102F" is "14" (with each value being shown in hexadecimal).

NOTE: For addresses that show an ON or OFF condition, "00" corresponds to OFF, and "FF" corresponds to ON.

8.2.8.1 Moving Around

Press "Nxt" to increase the addresses being displayed by 4.

Press "Prv" to decrease the addresses being displayed by 4.

Press "3" to increase the addresses being displayed by 10(Hex).

Press "6" to decrease the addresses being displayed by 10(Hex).

Press "2" to increase the addresses being displayed by 100(Hex).

Press "5" to decrease the addresses being displayed by 100(Hex).

Press "1" to increase the addresses being displayed by 1000(Hex).

Press "4" to decrease the addresses being displayed by 1000(Hex).

Press "Aux" to increase the addresses being shown by 1.

Press "Esc" to return to the Monitor Main Menu.

8.2.9 Enter Password

There is a common password for all controllers, which is "911". The password is required when changing a setting (such as Door Time, Fire Return Landing, etc.) or a feature (such as Fire Service Code, Front and Rear Door selections, etc.). The password operation has been changed so that unauthorized personnel cannot change the controller settings, but no unique password is required for each controller.

The password can be entered from the Setup Menu, as described below. Each time the Setup Menu is entered, the password access is cleared, so the password must be entered again. If the password is required for a menu item, a password entry screen will be displayed. Just press "911" then "Ent" to access the menu item.

Alternatively, the password can be entered by pressing the "7" key when the display is activated from the blank screen (after a power cycle), or when the "Virginia Controls" banner is displayed (after pressing "Esc" from the Monitor Menu). This allows the password to be entered without stopping the controller.

The password can be given to all authorized personnel, that is those who would need to change settings or features on the controller. It is recommended that the password NOT be written on the prints, or controller itself, as this would allow anyone to access settings and features that could cause damage to personnel or equipment.

Entering the Password allows access to the Change Features menu selection, and also allows changing the memory in the Show Internal Memory selection in the Monitor Mode.

Press "Ent" from the Setup Menu item to select this menu item.

Enter the password, then press "Ent".

A message will briefly be displayed indicating whether the password was correct or not.

The display will then move back to the Setup Menu.

If the password has been successfully entered, and it is desired to restore password protection, so that the password must be re-entered to gain access to the protected menu items, select the "Enter Password" menu item and enter an incorrect password. Password protection is also restored whenever the controller goes from the Monitor Mode to the Setup Mode.

8.2.10 Test I/O Boards

This selection is password protected. The password must be entered each time this menu item is selected, even if the password has been correctly entered before. The generic password "911" may be used. This prevents unauthorized personnel from activating this feature, and also prevents accidentally entering this feature.

After entering the password, the LCD screen will display "'Ent' = START TEST, OTHER KEY = QUIT". Press the "Ent" key to start the test feature, or press any other key to return to the setup menu.

WARNING: When the test feature is activated, outputs will be turned on that may cause the car to move, the doors to operate and other signals to come on. Take any and all the necessary precautions to prevent a dangerous situation.

This could include

- unplugging the terminal blocks on the input and output boards,
- removing the fuses on the output boards,
- opening the appropriate safety devices.

While the test feature is activated, each input that is on will turn on the output directly below that input. This allows the inputs and outputs to be tested by jumping the desired input on, and verifying that the proper output comes on. NOTE: The outputs are updated once every tenth of a second, so there may be a slight delay in turning on the output after the input has been energized.

While the outputs are being tested, a meter can be used to verify that each output is actually coming on.

WARNING: Be very careful when jumping the inputs on. Make sure you do not jump to the common on the input terminal strips. This will blow a fuse, and could damage the input board components. The input commons are the first and sixth terminals from the left on the input terminal strip (see the schematic).

8.3 Fault Logging

The fault logging feature will store the last 24 faults, with the latest 4 faults held through power loss. Each fault has an associated time code and two status codes recorded with the fault. If power is lost, the 20 non-retentive faults, stored at address locations 0800 to 083F, will probably contain invalid data. The four most recent faults will be stored at 0060 to 006F.

When the "Show Internal Memory" menu item in the Monitor Menu is selected, the display will show the values of memory addresses 0060 to 0067, which show the most recent faults. Refer to this manual, section 8.1.3 for instructions on using the "Show Internal Memory" mode.

8.3.1 Memory Addresses and Fault Log Function

<u>Address</u>	<u>Description</u>
----------------	--------------------

NOTE: The values in addresses 0060 through 006F are maintained through a power loss.

005F	Current Time Code.
0060	Fault Time Code of the most recent fault.
0061	Fault Code of the most recent fault.

- 0062 Fault Floor Code at time of most recent fault
 - 0063 Fault Status Code at time of most recent fault
 - 0064 Fault Time Code of the 2nd most recent fault.
 - 0065 Fault Code of the 2nd most recent fault.
 - 0066 Fault Floor Code at time of 2nd most recent fault
 - 0067 Fault Status Code at time of 2nd most recent fault
 - 0068- Codes of the next most recent faults. (faults 3-4).
 - 006F Sequence of codes is the same as shown above.
- The following time and fault codes are NOT maintained through a power loss.
- 0800- Codes of the next most recent fault.
 - 0803 Sequence of codes is the same as shown above.
 - 0804- The table is repeated for the rest of the fault table, with the same sequence of codes as shown
 - 083B above.
 - 083C- Codes of the oldest recorded fault.
 - 083F

For example, to monitor the most recent fault, go to the Show Int Memory screen, then navigate to address 0060. The top line of the screen will show the values in four consecutive registers, which contain all the data for the most recent fault, for example [0060 14 03 21 C4] where the address of the first register being displayed is shown at the left which is 0060; then the Fault Time Code which is 14; then the Fault Code which is 03; then the Fault Floor Code which is 21; then the Fault Status Code which is C4. Refer to each section below for an explanation of the codes used.

8.3.1.1 Time Code

The Fault Time Code is the value of the Current Time Code, address 005F, when the fault occurred. This is a number between 00 and FF(hexadecimal, or 255 decimal) that is used as a time stamp code. The number increases by one every ten minutes. By subtracting the time code of a particular fault from the current time code, you can determine how long ago the fault occurred. For example, if the Fault Time Code is 14, and the Current Time Code is 16, then the fault occurred 2 time periods ago which is 20 minutes. Alternatively the chart below can be used to determine when a fault occurred.

NOTE: If the Current Time Code is set to match the table below, then the Fault Time Code will also match the time shown in the table below. Refer to the section 8.1.3.3 to see how to change an internal value.

If the Current Time has not been set up, or is off, then compare the Current Time Code with the chart below, to see how far off the Current Time Code is, then adjust the value for the Fault Time Code accordingly. For example, if the Current Time Code (address 005F) is 62 (indicating the Current Time is 4:20pm), but the actual time is 5:10pm then the time code is 50 minutes slow and the Fault Codes should be increased by 50minutes. Thus if a fault occurred at Fault Time Code of 60, the table indicates this is 4:00pm, but this is now adjusted by 50 minutes so the fault really occurred at 4:50pm.

The Current Time Code changes every 10 minutes, so the times shown are only accurate to 10 minutes.

Every 24 hours, the value of the current time code will roll over, resetting to "00". A fault code of "00" is inserted into the fault table, which indicates faults before this code are from an earlier 24 hour time period.

If power is removed from the controller, then the Current Time Code will not increment.

Code	Time	Code	Time	Code	Time	Code	Time	Code	Time	Code	8:00 PM
00	12:00 AM	18	4:00 AM	30	8:00 AM	48	12:00 PM	60	4:00 PM	78	8:00 PM
01	12:10 AM	19	4:10 AM	31	8:10 AM	49	12:10 PM	61	4:10 PM	79	8:10 PM
02	12:20 AM	1A	4:20 AM	32	8:20 AM	4A	12:20 PM	62	4:20 PM	7A	8:20 PM
03	12:30 AM	1B	4:30 AM	33	8:30 AM	4B	12:30 PM	63	4:30 PM	7B	8:30 PM
04	12:40 AM	1C	4:40 AM	34	8:40 AM	4C	12:40 PM	64	4:40 PM	7C	8:40 PM
05	12:50 AM	1D	4:50 AM	35	8:50 AM	4D	12:50 PM	65	4:50 PM	7D	8:50 PM
06	1:00 AM	1E	5:00 AM	36	9:00 AM	4E	1:00 PM	66	5:00 PM	7E	9:00 PM
07	1:10 AM	1F	5:10 AM	37	9:10 AM	4F	1:10 PM	67	5:10 PM	7F	9:10 PM

Code	Time	Code	Time	Code	Time	Code	Time	Code	Time	Code	8:00 PM
08	1:20 AM	20	5:20 AM	38	9:20 AM	50	1:20 PM	68	5:20 PM	80	9:20 PM
09	1:30 AM	21	5:30 AM	39	9:30 AM	51	1:30 PM	69	5:30 PM	81	9:30 PM
0A	1:40 AM	22	5:40 AM	3A	9:40 AM	52	1:40 PM	6A	5:40 PM	82	9:40 PM
0B	1:50 AM	23	5:50 AM	3B	9:50 AM	53	1:50 PM	6B	5:50 PM	83	9:50 PM
0C	2:00 AM	24	6:00 AM	3C	10:00 AM	54	2:00 PM	6C	6:00 PM	84	10:00 PM
0D	2:10 AM	25	6:10 AM	3D	10:10 AM	55	2:10 PM	6D	6:10 PM	85	10:10 PM
0E	2:20 AM	26	6:20 AM	3E	10:20 AM	56	2:20 PM	6E	6:20 PM	86	10:20 PM
0F	2:30 AM	27	6:30 AM	3F	10:30 AM	57	2:30 PM	6F	6:30 PM	87	10:30 PM
10	2:40 AM	28	6:40 AM	40	10:40 AM	58	2:40 PM	70	6:40 PM	88	10:40 PM
11	2:50 AM	29	6:50 AM	41	10:50 AM	59	2:50 PM	71	6:50 PM	89	10:50 PM
12	3:00 AM	2A	7:00 AM	42	11:00 AM	5A	3:00 PM	72	7:00 PM	8A	11:00 PM
13	3:10 AM	2B	7:10 AM	43	11:10 AM	5B	3:10 PM	73	7:10 PM	8B	11:10 PM
14	3:20 AM	2C	7:20 AM	44	11:20 AM	5C	3:20 PM	74	7:20 PM	8C	11:20 PM
15	3:30 AM	2D	7:30 AM	45	11:30 AM	5D	3:30 PM	75	7:30 PM	8D	11:30 PM
16	3:40 AM	2E	7:40 AM	46	11:40 AM	5E	3:40 PM	76	7:40 PM	8E	11:40 PM
17	3:50 AM	2F	7:50 AM	47	11:50 AM	5F	3:50 PM	77	7:50 PM	8F	11:50 PM

8.3.1.2 Fault Code

The Fault Code is in the next address, after the Fault Time Code. Refer to the table below to determine the description for the Fault Code, and the possible causes.

<u>Fault Code</u>	<u>Fault Description</u>
00	Rollover Code. This Fault Code is inserted every 24 hours to show that the faults before this code were from the previous 24 hour time period.
01	Running Shutdown Timer. The car ran for the time specified by the "Shutdown Time" setting without passing a floor. The car will stop and return to the bottom landing. It is reset by cycling power or cycling the Inspection Switch. The probable causes are: (1) Low oil. (2) Up valve(s) did not operate properly. (3) Pump did not operate properly. Check that the setting of the shutdown timer is long enough for the car to run between floors. The normal shutdown timer setting is 25 seconds.
02	Door Open Fault. The Door Open Limit Switch failed to open after the doors had been opening for the time specified by the "Door Fault" setting. The probable causes are: (1) The Door Open Limit failure. (2) door operator failure. (3) door control circuitry failure.
03	Door Close Fault. The doors failed to close properly when they were parking, or when the car was ready to run for the next call. This fault will not be caused by keeping the doors open through the normal means (Door Open Button, Safety Edge, Infra-red Unit, etc.), but only if the doors should be closing but were not able to close. The probable causes are: (1) Door Close Limit failure. (2) Door Contacts failure. (3) door operator failure. (4) door control circuit failure.
04	Rear Door Open Fault. This is the same as fault 02, except it is for the rear door. This fault is only used on elevators with selective open doors (with a front and rear door at the same landing).
05	Rear Door Close Fault. This is the same as fault 03, except it is for the rear door. This fault is only used on elevators with selective open doors (with a front and rear door at the same landing).
06	Car Stuck Fault. The car was held at a floor for the time set by the "Car Stuck Time" setting, without running. This may be caused by a stuck button, or just by a passenger holding the car.
07	Battery Backup. The elevator went on battery backup, and completed the return cycle.
08	Door Contact Fault. The Door Contact Input turned off while the car was running. This fault could be caused by the car tipping a door contact, or another of the devices in the safety string. It could also be caused by a failure of the "DC" Door Contact relay.
09	Door Zone Fault. The car stopped between floors. This is normal when the car is being taken off Inspection Service. This fault will usually be seen with fault 08, since the car will usually stop

Fault Code Fault Description

	outside the door zone if the safety string is broken.
0A	Communication Failure on Duplex. This will occur when the power on the other car is turned off, or the other car fails to communicate properly for 5 seconds. Check the communication cable, and the termination jumpers, which are located by the communication cable terminal strip.
0B	Door Contacts Input was closed (indicating doors were closed) when the Door Open Limit was open (indicating doors were open). This is usually caused by jumping the Door Contacts.
0C	Leveling Switch Fault. Both Leveling Switch Inputs are on. This will shut the car down. Check the Leveling Switches. Cycle the power, or put the car on Inspection to clear the fault.
0D	Fire Service was initiated from a Smoke Sensor or the Fire Switch.
0E	The Machine Room or Shaftway Smoke Sensors were tripped.
0F	Fire Service Shunt Trip operation was initiated.
10	The Door Zone Input failed to open properly. This is usually caused by the Door Zone input being on when the car is between floors.
11	Redundancy Fault. The ESB monitoring input was off and the ESB output was off.
12	Redundancy Fault. The running monitoring input did not match the condition of the PLC. With this fault, Bit16 of the status code will show the status of the Run Input.
13	FS relay counter. The car tried to run fast speed 20 times, without passing a floor. This can be caused by the FS relays failing to cut out Leveling, or by the car clipping the Door Contacts as it leaves the floor.

8.3.1.3 Fault Floor Code

The left number in the Fault Floor Code is the floor number at the time of the fault, with "1" being the bottom landing, "2" the 2nd landing, etc. The right number in the Fault Floor Code is a composite value that shows the status of several individual functions, according to the table below. Select the column corresponding to the value of the right value of the Fault Floor Code to see which functions are on (Y=on, N=off).

Fault Floor Code (Right Value)

0	1	2	3	4	5	6	7	8	9	A	B	C	D	E	F	Description
N	Y	N	Y	N	Y	N	Y	N	Y	N	Y	N	Y	N	Y	Last run was UP (N=last run was Down)
N	N	Y	Y	N	N	Y	Y	N	N	Y	Y	N	N	Y	Y	Last direction was UP (N=last direction was Down)
N	N	N	N	Y	Y	Y	Y	N	N	N	N	Y	Y	Y	Y	Car was running at the time of the fault
N	N	N	N	N	N	N	N	Y	Y	Y	Y	Y	Y	Y	Y	Car was running fast speed at the time of the fault

8.3.1.4 Fault Status Code

The Fault Status Code is a composite value that shows the status of several individual functions, according to the table below. For each digit of the code, select the column corresponding to the value of the Fault Status Code to see which functions are on (Y=on, N=off).

Status Code (Left Value)

0	1	2	3	4	5	6	7	8	9	A	B	C	D	E	F	Description
N	Y	N	Y	N	Y	N	Y	N	Y	N	Y	N	Y	N	Y	The car was on a floor to floor run at the time of the fault
N	N	Y	Y	N	N	Y	Y	N	N	Y	Y	N	N	Y	Y	The Door Contacts Input was on at the time of the fault
N	N	N	N	Y	Y	Y	Y	N	N	N	N	Y	Y	Y	Y	The Door Closed Limit Input was on at the time of the fault
N	N	N	N	N	N	N	N	Y	Y	Y	Y	Y	Y	Y	Y	The Door Open Limit Input was on at the time of the fault

Status Code (Right Value)

0	1	2	3	4	5	6	7	8	9	A	B	C	D	E	F	Description
N	Y	N	Y	N	Y	N	Y	N	Y	N	Y	N	Y	N	Y	The Up Level Input was on at the time of the fault
N	N	Y	Y	N	N	Y	Y	N	N	Y	Y	N	N	Y	Y	The Down Level Input was on at the time of the fault
N	N	N	N	Y	Y	Y	Y	N	N	N	N	Y	Y	Y	Y	The car was in the Door Zone at the time of the fault
N	N	N	N	N	N	N	N	Y	Y	Y	Y	Y	Y	Y	Y	Unassigned

8.3.1.5 Fault Code Example

For example, if the display shows [0060 3D 03 21 C4] then the address you are monitoring is 0060, which is the first (most recent) fault.

- The time stamp for that fault is "3D", which can be compared to the value of address 005F to determine how old the fault is. If the Current Time Code has been set so that it matches the current time, then the fault occurred at 10:10am, (see the Time Table above)
- The Fault Code is "03" which is a Door Close Fault. The Doors failed to close properly.
- The Floor Code is "21" which indicates the car was at the 2nd floor when the fault occurred (left value is "2"), and the last run was up; the last direction preference was down; the car was not running (right value is "1", see the Fault Floor Code table above, using the column headed "1").
- The Status Code is "C4" which indicates the Door Open Limit Input and the Door Close Limit Input were both on (see the Status Fault Code Left Value table, using column "C") and the car was in the Door Zone (see the Status Fault Code Right Value table using column "4").

9. Troubleshooting Suggestions

Troubleshooting is similar to any other controller, and has several features to speed up determining the cause of any problem. No special knowledge of the operation of the micro-processor is required to be able to troubleshoot it.

A safety relay interface is provided to prevent dangerousness. It is possible that the micro-processor may turn on an output point, yet the field safety switches may prevent the associated device from energizing. For example, if the up run output energizes, but the up normal switch is open, then the up run valve(s) will not energize.

9.1 Locating Faults

Once the system has been installed, and is running properly, the most common problem will be the failure of an external device. The first step in locating the cause is to determine whether the fault is in the micro-processor or whether it is in the external wiring. For example, if a position indicator light is not lit, check the output module for the appropriate output point to determine if the micro-processor is trying to turn the light on or not. If the output light is on, then confirm that there is voltage at the module terminal. If there is voltage at the module terminal, then the problem is external to the micro-processor. It could be in the wiring to the position indicator, or perhaps the position indicator light has burned out. Similarly with input points, check that the input module light is on, that there is power at the terminal, and if not then the problem is external.

If it is determined that the problem is with the micro-processor, then the next step is to determine if the problem is in the hardware or the software. Using the keypad, press "Nxt" to display the "Show I/O Status" menu item. Press "Ent". The screen will show the address on the top line and the I/O status on the bottom line. Press "Nxt" or "Prv" to show the desired I/O address, and see if the CPU is responding by showing the correct status of the I/O points. If it is not, then the fault is probably with the I/O hardware; if it is on, then the fault is probably with the software.

If an input or output board fails, it may be possible to temporarily replace that defective board with another board that is used for non-essential functions (such as call register lights), thus providing elevator service while a replacement board is being obtained. See the section on "I/O Board Replacement" for further information.

If this does not correct the problem, the power supply or the CPU module could be faulty. If the CPU fails, it will probably stop flashing LED L5. The CPU and I/O modules can be affected by high transient surges in the power supply, such as the building being hit by lightning. This may damage the CPU, or alter the contents of the program. Proper grounding will protect the controller from most of these problems.

9.2 I/O Board Replacement

WARNING: When replacing a board, the address jumper(s) on the new board must be set to match the old board. The 24point I/O boards have one address jumper, (A,B,C,D). The 8point I/O boards have two address jumpers, (A,B,C,D and 1,2,3,4)

To replace an I/O board, unplug all the terminal blocks at the top and bottom of the board. Work the ribbon cable off the I/O Bus Connector at the left of the I/O Board (this might be easier to do after the board has been unscrewed from the controller). Remove the screws holding the board in place. Install the new module by reversing the above steps.

9.3 Factory Assistance

IMPORTANT: IF TROUBLESHOOTING ASSISTANCE IS REQUIRED FROM VIRGINIA CONTROLS, GET THE FOLLOWING INFORMATION BEFORE CALLING (ADDITIONAL TROUBLESHOOTING INSTRUCTIONS MAY BE GIVEN, DEPENDING ON THE NATURE OF THE PROBLEM):

- **THE VIRGINIA CONTROLS DRAWING NUMBER** (located at the bottom right of the schematic).
- **AN EXACT DESCRIPTION OF THE PROBLEM.**
- **THE STATUS OF ALL THE INPUT AND OUTPUT POINTS.**
- **THE STATUS OF THE LIGHTS ON THE CPU.**

9.4 Changes for Program Revisions

The following section lists the changes that are included in program revisions.

9.4.1 Program Revision 11

Approximate Date of implementation – 6/10/1998

- A feature for Door Check circuitry was added. This requires external circuitry to be fully operational, and is enabled or disabled by the "ENABLE DOORCHECK" feature in the features section of the setup menu, after the "CALL I/O SEPARATE" feature. If the appropriate I/O is provided, and the feature is enabled, then the doors will be held open if the Car or Hall Door Contacts Input is energized, but the doors are still open. This feature should be disabled if not required, or if the appropriate I/O is not provided.
- A setting for the Home Landing was added for passenger simplex controllers. This allows the Home Landing to be set to a different floor from the Fire Service Main Return Floor. The Home Landing can be changed by changing the "HOME LANDING" setting under Change Settings in the setup menu, and it is located after the Fire Service Alternate Landing Setting. Unless otherwise specified, this setting is set to the same value as the Fire Service Main Landing.

9.4.2 Program Revision 12

Approximate Date of implementation – 11/9/1998

- A "No BORIS Defeat" feature for allowing BORIS to lower under any circumstances was added. The location of this setting is after the Fire Service selections, and the LCD display will show "NO BORIS DEFEAT". With this feature set, the car will automatically lower if it can. If the car is on Inspection, the car may be run down, but not up. This feature requires BORIS circuitry to be installed on the controller. The setting of this feature will not affect the operation of the controller if BORIS is not provided.
- A "BORIS on Out of Service" feature for allowing BORIS to lower when the car is Out of Service but NOT on Fire Service, was added. The location of this setting is after the Fire Service selections, and the LCD display will show "BORIS ON OUTSRVC". With this feature set, the car will automatically lower if it can, even if the car is on Medical Emergency, Attendant, Independent or Inspection Operation. If the car is on Inspection, the car may be run down, but not up. If the car is on Fire Service the car will not lower automatically, but will shutdown wherever it is. This feature requires BORIS circuitry to be installed on the controller. The setting of this feature will not affect the operation of the controller if BORIS is not provided.

9.4.3 Program Revision 15

Approximate Date of implementation – 1/17/2000

- A "NO RUN ON FIRE SERVICE AND BORIS" feature was added. If this is DISABLED (factory default) then the car will lower on BORIS, even if the car is on Fire Service. If this is ENABLED, then the car will NOT lower on BORIS when the car is also on Fire Service. If the car is on Inspection, the car may be run down, but not up. This feature requires BORIS circuitry to be installed on the controller. The setting of this feature will not affect the operation of the controller if BORIS is not provided. The location of this setting is after the Fire Service selections, and the LCD display will show "NO RUN=EFS+BORIS".
- A "NO RUN ON FIRE SERVICE AND SHUTDOWN" feature was added. If this is DISABLED (factory default) then the car will lower on shutdown, even if the car is on Fire Service. If this is ENABLED, then the car will NOT lower on shutdown when the car is also on Fire Service. If the car is on Inspection, the car may be run down, but not up. The location of this setting is after the setting described above, and the LCD display will show "NO RUN=EFS+SHTDN".

- A “STOP AT THE MAIN LANDING ON SHUTDOWN” feature was added. If this feature is DISABLED (factory default) then the car will lower to the bottom landing on shutdown, BORIS, Emergency Power, and Low Oil. If this feature is ENABLED, then the car will stop at the main landing if it passes it on the way down to the bottom landing. The car will stay at the main landing, unless it sinks out of the Door Zone, in which case it will run down to the bottom landing. The location of this setting is after the setting described above, and the LCD display will show “STOP MF ON SHTDN”.

9.4.4 Program Revision 16

Approximate Date of implementation – 6/1/2001

- “CUSTOM TIME 1.1” is the Flash Rate for the Fire Light on 1998 ANSI Code, if the Machine Room or Hoistway Fire Sensors are energized. The default setting is 2.0 seconds.
- “CUSTOM TIME 3.3” is the delay before shutting off the Position Indicators. The default value is 30, which is equal to 300 seconds or 5 minutes.
- “CUSTOM FEATURE 1” will disable the timed shut off of the Position Indicators. Enable this feature to keep the Position Indicators on at all times.
- “CUSTOM FEATURE 2” will disable the shortened Door Time from the Door Close Button. With this feature disabled, the Door Close Button will drop the Hall Call Door Time (usually 5 seconds) to the Shortened Door Time (usually 1 second) when the Door Close Button is pressed. With this feature enabled, then pressing the Door Close Button will shorten the Hall Call Door Time to the Car Call Door Time (usually 3 seconds).
- “SPECIAL FEATURE 1” will allow the Emergency Stop Switch Bypass Output to drop after the car has returned to the Main Landing. Most codes required that this feature be disabled (default)
- “SPECIAL FEATURE 2” will prevent the Shunt Trip operation on Fire Service Phase 2, if provided. The default is disabled, which will allow Shunt Trip on Fire Service Phase 2.

9.4.5 Program Revision 17

Approximate date of implementation – 6/28/2002

All Settings and Features are now shown in the schematic on sheet “MH2000 SETTING”. Several settings have been added that are coded to give multiple selections, and some features have been moved to these new settings. To determine the proper value for these settings, determine whether the individual setting described in the table on sheet “MH2000 SETTINGS” should be on or off. Then add up the value in the “Val” column for all the features that should be on. Enter this value for the setting. The factory default value is shown on the sheet “MH2000 SETTINGS” and is based on the information provided when the job was ordered. If any special settings are provided for a job, these will be documented on the sheet “MH2000 SETTINGS”, or on supplemental sheets provided with the MH2000 Manual.

The following New Features and Settings have been added. Not all settings are used on all jobs. Check the sheet “MH2000 SETTINGS” for the settings available on a specific job:

- “FRONT DOOR CODE” is a value that determines where the front door openings and rear door openings are on systems with front and rear doors. If the elevator has non-selective doors (without walk-throughs) then turning off the front door will enable the rear door at that floor. On systems with selective doors (walk-throughs) then turn on the front doors at front openings, and turn on the rear doors by means of the Rear Door Code at rear openings.
- “REAR DOOR CODE” is a value that determines where the rear door openings are on selective (walk-through) door installations. The proper value is determined by adding the value for each landing that should have a rear opening, according to the table shown in the schematic on sheet “MH2000 SETTINGS”. For example, to enable rear doors at the 1st, 2nd, and 4th landings, add up the values in the “Val” column, which gives a value of $(1+2+8)=11$.
- “LOW ZONE CODE” is a value that determines on Duplex systems which landings are in the Low or Lobby Zone. The value will determine which floors the Lobby car will respond to, with the other car responding to non-Low Zone calls.
- “FEATURES CODE 1”, “FEATURES CODE 2”, “FEATURES CODE 3” are values that sets 8 individual features according to the table shown in the schematic on sheet “MH2000 SETTINGS”.
- “CUSTOM VALUE # 1”, “CUSTOM VALUE # 2”, “CUSTOM VALUE # 3” are unassigned values. Check the sheet “MH2000 SETTINGS” in the schematic to see if this value is used on a particular job.

- “DR CLOSE ON FIRE” is the time delay before closing the doors on Fire Service, when shutdown has been initiated, and the system is set for ANSI 2000 Fire Code.
- “PI SHUT OFF TIME” is the time delay before turning off the Position Indicators. To prevent the Position Indicators from turning off, set this value to 0.
- “FIRECODE-CHICAGO” enables the 2000 Chicago Fire Code.
- “FIRE CODE – 2000” enables the ANSI 2000 Fire Code
- “ENABLE CKO+INDEF” enables the CKO output, if used, when the car is on Independent Service. This output is used to disable Car Call Cutout Switches, if used.
- “CUSTOM TIME 1.1”, “CUSTOM TIME 3.3”, “CUSTOM FEATURE 1”, “CUSTOM FEATURE 2”, “SPECIAL FEATURE 1”, “SPECIAL FEATURE 2” no longer have a pre-defined functions.
- Only one door operator will be allowed to operate at a time on BORIS operation.
- ESB output will be maintained once the car has returned on Fire Service Phase 1, even after the completion of the return operation, as required by the code.
- The Door Close Button will always shorten the Door Time to the minimum setting.
- This manual has been revised so that references to older forms of operation have been removed.

Some installations require specific settings or features that are not included in the standard program. In this case, a separate sheet (or sheets) will be provided that describe the operation of these settings or features, and what the factory default settings are.

The following changes have been made to the operation of the menus and display:

- When entering a setting value, after the value has been entered and the Enter key has been pressed, if the value is acceptable, the message “Value Saved” will be briefly displayed, then the screen will show the new value (rather than stepping to the next item in the menu).
- When monitoring the Internal Memory on-line, and if the password has been entered, you can change the value of the address in the top left location by pressing the “.” (period) key, then one of the following keys:

“1” will increase the value by 40H	“4” will decrease the value by 40H
“2” will increase the value by 10H	“5” will decrease the value by 10H
“3” will increase the value by 04H	“6” will decrease the value by 04H
“Nxt” will increase the value by 01H	“Prv” will decrease the value by 01H
“0” will set the value to 00H	“9” will set the value to FFH
“8” will invert the value	“7”, “AUX” will not do anything.

- If the 1st pole of the Slide Switch on the CPU is turned on, then when the CPU is powered up, the screen will display the Banner Screen. With the 1st pole of the Slide Switch turned off, then the screen will be blank when the CPU is powered up, and will only display data when a key is pressed.

The Fault Log has been changed so that the Time Code increments every 10 minutes, not every 6 minutes. The following fault codes have been added:

- Fault “0B” – Door Contact Input was closed (indicating the doors are closed) with the Door Open Limit open (indicating the doors are open). This is usually caused by jumping the Door Contacts.
- Fault “0D” – Fire Service was initiated from a Smoke Sensor or the Fire Switch.
- Fault “0E” – Machine Room or Hoistway Smoke Sensor(s) tripped.
- Fault “0F” – Fire Service Shunt trip operation was initiated.
- Fault “10” – The Door Zone Input failed to open or close properly.
- Fault “11” – Redundancy Fault. The ESB monitoring input was off and the ESB output was off.
- Fault “12” – Redundancy Fault. The running monitoring input did not match the condition of the PLC. With this fault, Bit16 of the status code will show the status of the Run Input.
- Fault “13” – FS relay counter. The car tried to run fast speed 20 times, without passing a floor. This can be caused by the FS relays failing to cut out Leveling, or by the car clipping the Door Contacts.

9.4.6 Program Revision 17.D

Approximate date of implementation – 10/16/2003

The following changes were incorporated:

- Minor changes to Fire Service, especially with 2000 Code.

- Door Security feature added for systems with Selective Opening doors, including the ability to defeat the security by means of the “Always Enable DOB at Front/Rear Openings” features.
- Non-Interference and In Use Light operation was changed on Single Automatic Pushbutton systems.
- Independent Homing was added to Single Automatic Pushbutton Operation systems. This allows the homing floor to be different from the Main Fire Landing.

10. Controller Maintenance

WARNING: MAKE SURE THE POWER IS OFF BEFORE CONNECTING OR DISCONNECTING ANY CONNECTORS, ADDRESS JUMPERS OR CABLES ON THE CPU OR I/O BOARDS.

10.1 CPU Exchange

To swap out the CPU board:

1. Turn off the power to the controller.
2. Note the location of all cables and wires. It is recommended that all cables and wires be marked so that they can be returned to the correct terminal or connector, and be oriented properly.
3. Remove the incoming power wiring from the bottom right terminal block. Make sure you mark the wires so that they are reconnected properly.
4. Remove the duplex communication wires from the duplex connector (if used). Make sure you mark the wires so that they are reconnected properly.
5. Remove the keypad cable and I/O cable. (It may be easier to remove the I/O connector when the CPU board has been unscrewed from the mounting plate.)
6. Remove the four screws holding the CPU board in place.
7. Remove the CPU board.
8. Install the new CPU board in the reverse order, being careful to note the polarity of the wires in the power supply terminal block and duplex communication terminal block, and lining up the keypad connector properly.

10.2 EPROM Memory Exchange

WARNING: IF YOU NEED TO CHANGE THE EPROM PROGRAM CHIP ON THE CPU BOARD, MAKE SURE YOU READ THE INSTRUCTIONS AND KNOW EXACTLY HOW TO INSTALL THE NEW CHIP. PLUGGING THE EPROM IN UPSIDE-DOWN MAY DAMAGE YOUR CHIP. STATIC ELECTRICITY CAN DAMAGE THE EPROM, SO AVOID TOUCHING THE PINS ON THE CHIP, AND GROUND YOURSELF (BY TOUCHING THE CONTROLLER CABINET) BEFORE TOUCHING THE CHIP OR THE CONTROLLER. DO NOT EXPOSE THE EPROM PROGRAM CHIP TO BRIGHT LIGHT, AND DO NOT REMOVE THE LABEL OVER THE EPROM PROGRAM CHIP WINDOW.

To exchange the EPROM memory chip on the CPU board:

1. Turn off power to the controller.
2. Using a small screwdriver, or other appropriate tool, pry out the old EPROM chip by inserting the screwdriver between the chip and its socket from the bottom end (the end with the notch in the EPROM chip). Gradually work the chip out, trying to avoid swinging it out, which would bend the pins at one end, but rather prying it straight out by working the screwdriver under the chip from both ends.
3. Insert the new EPROM chip by orienting it properly, so that the notch is at the bottom, to match the socket, and all the pins line up with the socket. It should not be necessary to use force to insert the EPROM chip, but apply slight sideways pressure to line up the rows of pins with the holes in the socket, then evenly press the EPROM chip into place.
4. Do not apply power until the orientation of the chip has been checked. Also verify that ALL pins are properly in the socket, and that none of them have been bent out of place.

10.3 Input/Output Board Exchange

To exchange on I/O board:

1. Change the address jumper(s) on the new I/O board to match the board it will replace. On 24point I/O boards there is only one address jumper, on 8point I/O boards there are two address jumpers.
2. Unplug all the removable I/O terminal strips from the top and bottom of the I/O board. It is not usually necessary to mark the terminal blocks, since the wiring will normally hold them in the proper place so that it is obvious which block goes where. If there is any doubt about their location, then mark the terminal blocks to show where they should be re-installed.
3. Remove the screws holding the I/O board in place.
4. Gently unplug the ribbon cable from the connector at the left edge of the I/O board, being careful not to bend the pins in the connector.
5. Install the new I/O board by reversing the previous steps.

11. Frequently Asked Questions

Suggestions for other Frequently Asked Questions are welcomed. Please submit them to Chris Wilson at Virginia Controls.

11.1 Questions on Field Devices

Q. Are the Reset Targets necessary when using a pulsing selector?

Yes.

The reset targets are required at the terminal landings, as shown on the car top selector installation sheet, to establish or reset the floor position at the terminal landings.

Q. Why are Two Position Indicators energized at the same time?

With Floor Switches, if there is an overlap of the slowdown targets, or a Floor Switch sticks on, then when the car hits a new Floor Switch, all floors that have a Floor Switch input energized will be turned on. The floor position will be corrected when the car hits the next floor switch.

If the problem happens intermittently, it is probably caused by a sticking Floor Switch. If it happens regularly at a particular floor, there is probably an overlap between Floor Switches. In this case, either separate the Floor Switches (or targets) so there is no overlap, or turn on the "Short Floor" feature, described above in the features section.

11.2 Questions on the Controller

Q. How Do I Reset All Settings and Features Back to the Original Values?

1. With the controller running normally, press "Nxt" repeatedly until the menu item shows "GO TO SETUP MENU".
2. Press "Ent". The display will show a warning message.
3. Press "Ent". The display will show you have entered the Setup Mode, then display the "RESET SETTINGS" menu item.
4. Press "Ent" to reset all settings to the factory defaults.
5. Press "Esc" to return the controller to normal operation.

Q. How do I check the current values of the settings and features?

1. Go to the Setup Menu.
2. Select the menu item "Change Settings", and press "Ent", then enter the password, if required. (The password is required on programs version 8 and later, and is "911")

3. Scroll through the settings by pressing "Nxt". The settings will not be changed unless a new value is entered and then "Ent" is pressed.
4. Press "Esc" then "Nxt" to go to the "Change Features" menu item.
5. Press "Ent", then enter the password, and press "Ent".
6. Press "Nxt" to scroll through the features. The features will not be changed unless you press "Aux" then "Ent".
7. Press "Esc" twice to return to normal operation (Monitor Mode).

Q. Why is the LCD Display blank?

The LCD Display goes blank after the CPU resets. This will happen when the power to the CPU is cycled, or when the Reset Button on the CPU board is pressed.

Press any key to activate the screen.

If the screen does not activate, the problem could be with the Keypad (check that the cable is correctly installed) or the CPU (check that LED L5 is flashing), or the LCD Display.

The screen can be set to show the banner on power up by turning on the first position of the Slide Sw SW2 on the CPU. This must be turned off if the LCD Display is removed, or the CPU may lock up.

Q. Why doesn't the Keypad scroll through the menus properly?

The most likely cause is that the ribbon cable between the keypad and the CPU board is not installed correctly. The usual symptoms are that the keys do nothing, or they seem to have their functions swapped.

Check that the cable connector at the keypad is lined up, so that no pins are exposed at the left or right of the connector on the keypad. Check that the cable connector is lined up with the connector on the CPU board. Check that the wire at the top edge of the connector on the CPU goes to the left side of the connector on the keypad (by the "1" button), and the wire from the bottom edge of the connector on the CPU goes to the right side of the connector on the keypad (by the "Nxt" button).