

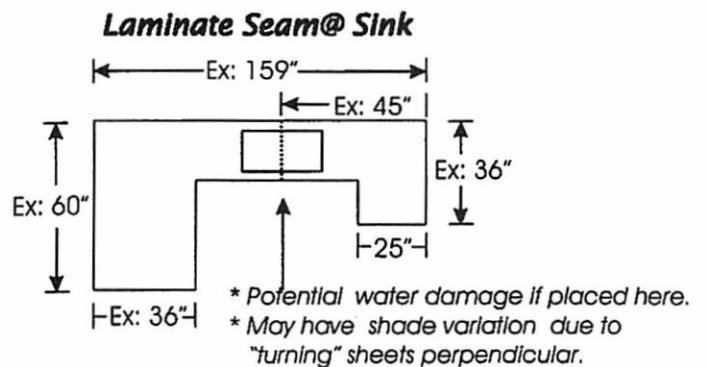

Custom Laminate Seams & Joints

- LAMINATE SEAMS:**
- * Laminate seams with custom tops are needed due to laminate sheet size availability.
 - * The largest size laminate is 60" x 144".
 - * The largest assembled top for shipping is 72" x 168" overall.

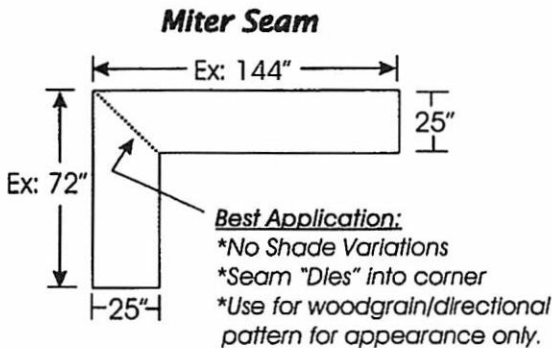

- MITERS & BUTT-JOINTS**
- * Unassembled joints are required ease of handling, transportation and installation..
 - * Use miter joints whenever possible, it helps eliminate front edge seam.
 - * Always use water resistant wood glue when assembling joints to prevent water damage. Water damage is not covered under Counter Pro warranty.

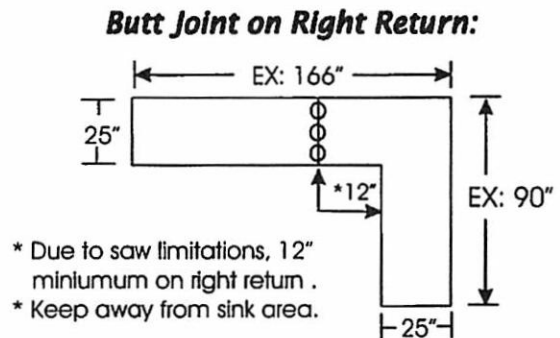
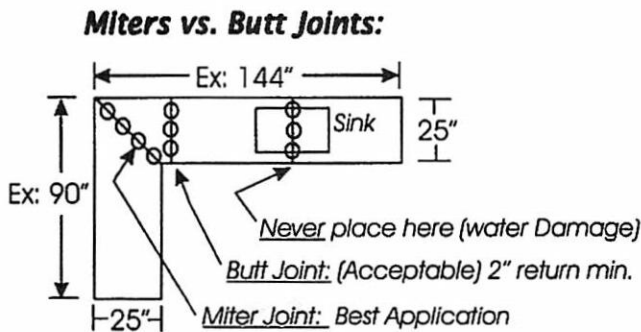

- OFFSET MITER JOINTS**
- * Use with Square Edge, wood edge or bevel edge.
 - * Allows for longer lengths without additional joints/seams.
 - * Eliminates front edge seam that would be visible with butt joint..

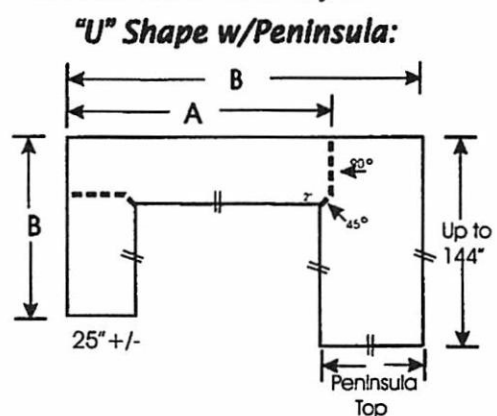
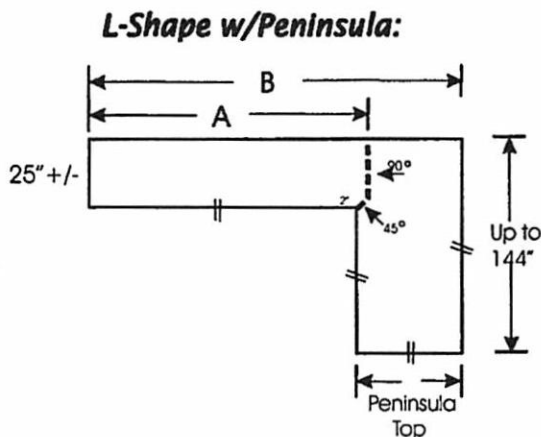



Butt Joints for U-Shaped Custom Counter Tops

When cutting butt joints for custom self edge, custom wood edge and custom bevel edge. Counter Pro, Inc. Prefers to machine both sides of a joint for the smoothest fit for assembling the joint at a job site. The following drawing shows the areas on where to place a butt joint when it is close to a corner.

Butt Joint **Left**

Butt Joint **Right**

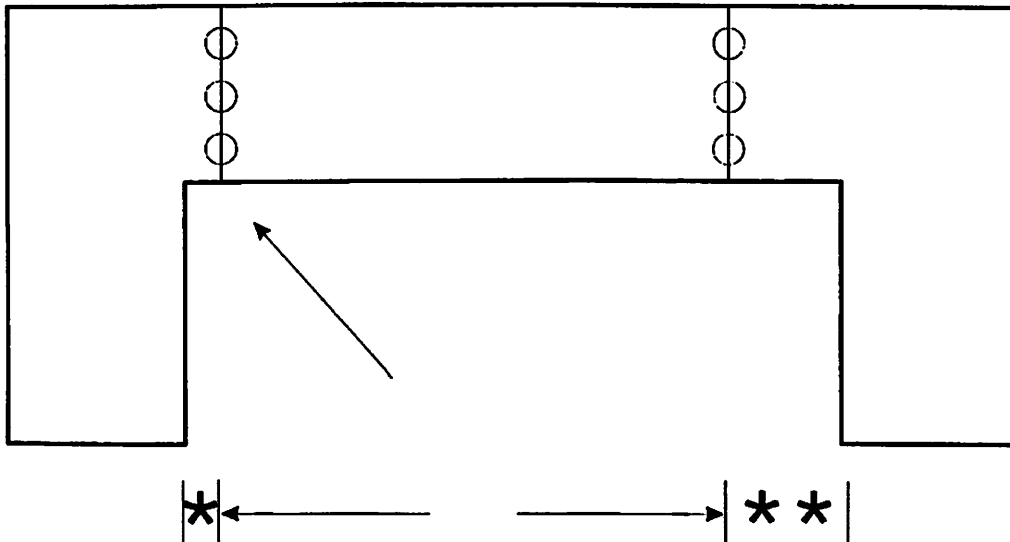

* The Left side may be as close as 1 1/2" from the inside corner.

** The Right side must be a minimum of 12" away from the inside corner.

Note:

- ➡ Whenever possible, use a mitre joint (45 Degree Cut). It is the best location for a joint for assembly, sheet material, and it is the least visible (butt joints show the front edge seam).
- ➡ Always keep joints away from the sink area or work area to help prevent water damage, which is not covered under warranty.
- ➡ Always use water proof wood glue when assembling any joint to help prevent water damage.
- ➡ Straight "laminated seams" must be placed a minimum of 3" in from each corner.

Custom Square Edge Fabrication Center

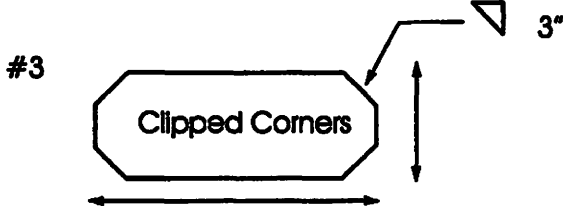
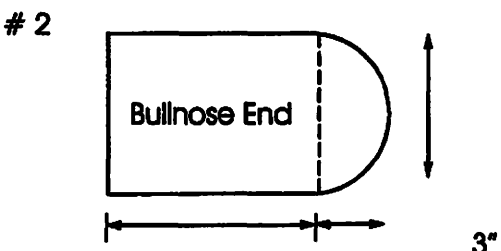
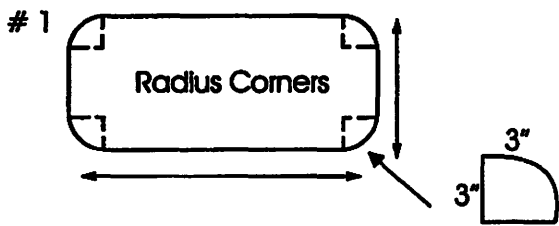

Note: Allow proper overhang for #1, #2, #3

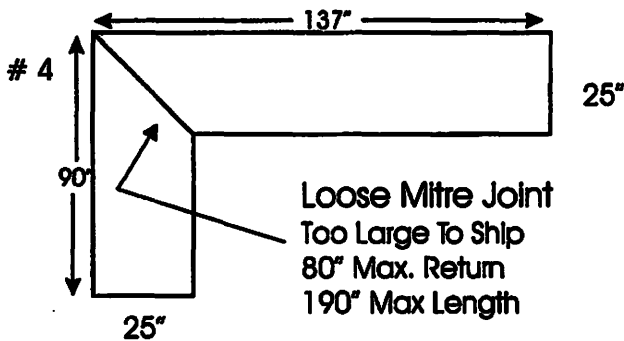

1. Please be sure to provide the required information on all orders.
2. Allow proper overhang when ordering radius and clipped corners.
3. When supplying cabinet dimensions, please specify requested overhang; i.e. angle, end base, angle cuts
4. Make sure that you indicate whether dimensions given are cabinet or countertop.

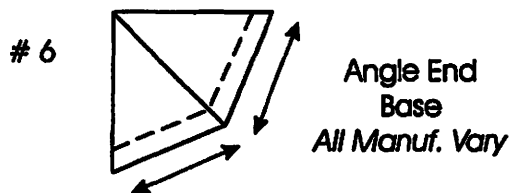
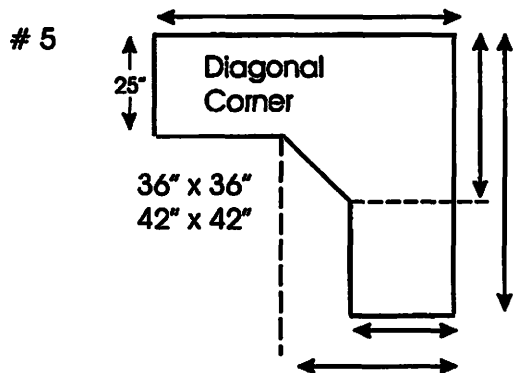

Note: A 1" Overhang on the front, actually ends up 1 1/8" at the end point

