



RCHW Series

Polycase

Residential/Commercial/Light Industrial Surge Protection Device

The RCHW/POL Series provides **high-energy surge protection** and optional **RF filtering** for Residential, Commercial, Industrial and Remote Site applications.

These hardwired units provide superior control over transients by delivering low clamping voltages combined with high surge energy handling capabilities. All RCHW/POL models are Type 1 or Type 2 Surge Protection Devices that are listed to **ANSI/UL 1449**.

They are configured for **quick and easy parallel installation** and require little maintenance while in service. The superior energy handling capabilities of the RCHW/POL Series is due to the utilization of large diameter MOV technology.

The RCHW/POL Series is available for all service voltages and phase configurations and can be equipped with several specialized diagnostic options. All Models have a 100kA RMS symmetrical fault current rating suitable for all IEEE category C locations and are available with surge ratings of 50kA or 100kA per phase.



Dimensions

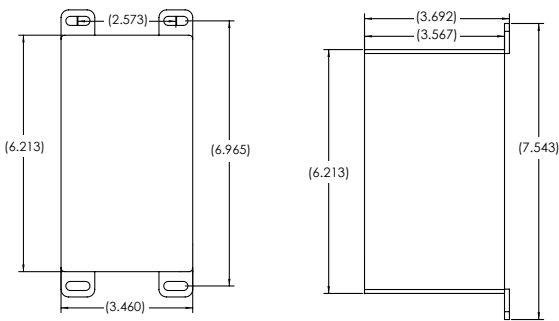

(Diagrams not drawn to scale)

Typical Installations

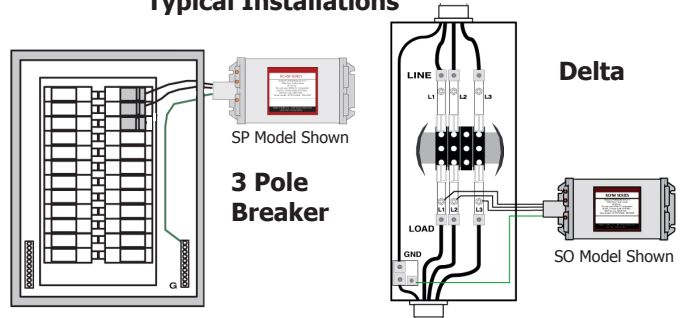

Product Specifications	
I_n	20 kA*
Max Surge Current	50kA to 100kA per Phase
Fusing	Coordinated Surge & Thermal
Short Circuit Current	100kA RMS Symmetrical

* Devices that are rated 480V delta have a 10kA I_n

Mechanical/Environmental Specifications	
Diagnostics	Red Status LED, SUNBRIGHT
Safety Standards (Type 1 SPD)	ANSI/UL 1449
Housing Ratings	NEMA 4X Polycarb - Standard

Model Number	Service Voltage	MCOV	L-N	L-G	N-G	L-L
RCHWxxx/120-10-#-1/POL	120 Volt Single \emptyset	150Vac	600V	600V	600V	N/A
RCHWxxx/120-SP-#-1/POL	120/240 Volt Split \emptyset	150Vac	600V	600V	600V	1200V
RCHWxxx/120-3W-#-1/POL	120/208 Volt 3 \emptyset Wye	150Vac	600V	600V	600V	1200V
RCHWxxx/120-3H-0-1/POL	120/240 Volt 3 \emptyset Delta	150/320Vac	600/1000V	600/1000V	600V	1200/1800V
RCHWxxx/240-3D-0-1/POL	240 Volt 3 \emptyset Delta	320Vac	N/A	1000V	N/A	2000V
RCHWxxx/220-3W-#-1/POL	220/380 Volt 3 \emptyset Wye	320Vac	1000V	1000V	1000V	2000V
RCHWxxx/230-3W-#-1/POL	230/400 Volt 3 \emptyset Wye	320Vac	1000V	1000V	1000V	2000V
RCHWxxx/240-3W-#-1/POL	240/415 Volt 3 \emptyset Wye	320Vac	1000V	1000V	1000V	2000V
RCHWxxx/277-3W-#-1/POL	277/480 Volt 3 \emptyset Wye	320Vac	1000V	1000V	1000V	2000V
RCHWxxx/480-3D-0-1/POL	480 Volt 3 \emptyset Delta	520Vac	N/A	1800V	N/A	4000V

1. Replace xxx with: 050 for 50kA or 100 for 100kA per phase Surge Ratings.
3. Options: Add - TB to the end of the model number for Terminal Block option.

2. Replace # with: F if filtering is required (available option on WYE Models only).
4. Add: - DIN to the end of the model number for the Din Rail Mount.

All product dimensions provided are ± 0.125

Meter Treater Inc.: 1349 South Killian Drive • Lake Park, FL 33403

Email: sales@metertreater.com

Sales: 561.845.2007 Toll: Free: 800.638.3788 Fax: 561.848.2372

Website: www.metertreater.com

120/240VAC, High Leg Delta, 4 Wire + Ground
 120/208VAC, Three Phase Wye, 4 Wire + Ground
 277/480VAC, Three Phase Wye, 4 Wire + Ground

240VAC, Three Phase Delta, 3 Wire + Ground
 480VAC, Three Phase Delta, 3 Wire + Ground

WARRANTY INFORMATION

RCHW Series Hardwire Device

USER MANUAL AND INSTALLATION GUIDE (ALL MODELS)



The RCHW is a Type 1 Device (IEEE Category C)
 The RCHW Series is built to both UL's OWHX
 (Secondary Surge Arrestor) and 1449 Fourth Edition
 SPD Standards

SURGE PROTECTION DEVICES FOR
AC POWER APPLICATIONS

RESIDENTIAL & COMMERCIAL
INSTALLATIONS

Meter-Treater, Inc. (MTI) warrants all RCHW Series models to be free from defects, and will at our option repair or replace the product should it fail within fifteen (15) (residential installations) years from the first date of shipment. This warranty is limited to defects in workmanship or materials, and does not cover customer damage, abuse or unauthorized modification. If this product fails or does not perform as warranted, your sole recourse shall be repair or replacement as described above. Under no condition shall MTI be liable for any damages incurred by the use of this product. Damages include, but are not limited to, the following: lost profits, lost savings and incidental or consequential damages arising from the use of or inability to use this product. MTI specifically disclaims all other warranties, expressed or implied, and the installation or use of this product shall be deemed an acceptance of these terms by the user.

WARRANTY RETURNS

All warranty and non-warranty repairs must be returned freight prepaid and insured to MTI. All returns must have a Return Authorization (RA) number on the outside of the shipping container. This number may be obtained from MTI Warranty Department (800) 342-6890. Products returned without an RA number will not be accepted.

IF UNIT(S) ARE RECEIVED DAMAGED,
NOTIFY THE SHIPPING COMPANY
IMMEDIATELY. RETAIN ALL SHIPPING
CONTAINERS AND PACKING MATERIALS
FOR INSPECTION.

Please Note:
There are no user serviceable parts inside.



Meter-Treater, Inc.
 1349 South Killian Drive • Lake Park, FL 33403
 Phone: 561.845.2007 • Fax: 561.848.2372
 Email: sales@metertreater.com
 Website: www.metertreater.com

MTI-RCHWINSTALL-72016

1. Deenergize as much as possible prior to installation.
2. Locate the mounting position of the SPD as close as possible to the electrical connection point. The SPD may be connected directly to the load side of the meter socket via spare/additional lugs or through a disconnect, fuse or circuit breaker rated not less than 30 amps.
3. Prepare any supplementary conduit, or other materials for wire routing. Minimize right angles as they will degrade overall SPD performance.
4. Mount the device in your predetermined location next to the panel or equipment to be protected.
5. Connect the Green Ground wire to the system ground.
6. Connect the White Neutral wire to the neutral bus. Where there is no neutral bus and the SPD is equipped with a white neutral wire, the white neutral wire from the SPD should be connected to ground.

7. If applicable, for high leg delta systems, connect the orange wire to the high leg phase. **CONNECTING A BLACK WIRE TO THE HIGH LEG OF A HIGH LEG DELTA WILL DAMAMGE THE SPD**

8. Connect the Black Phase wire(s) to each phase.

9. Energize the circuit if applicable. Check that the LED light is on.

1. Deenergize as much as possible prior to installation.
2. Locate the mounting position of the SPD as close as possible to the electrical connection point. The SPD may be connected directly to the load side of the meter socket via spare/additional lugs or through a disconnect, fuse or circuit breaker rated not less than 30 amps.
3. Prepare any supplementary conduit, or other materials for wire routing. Minimize right angles as they will degrade overall SPD performance.
4. Mount the device in your predetermined location next to the panel or equipment to be protected.
5. Connect the Green Ground wire to the system ground.
6. Connect the Black Phase wire(s) to each phase.
7. Energize the circuit if applicable. Check that the LED light is on.

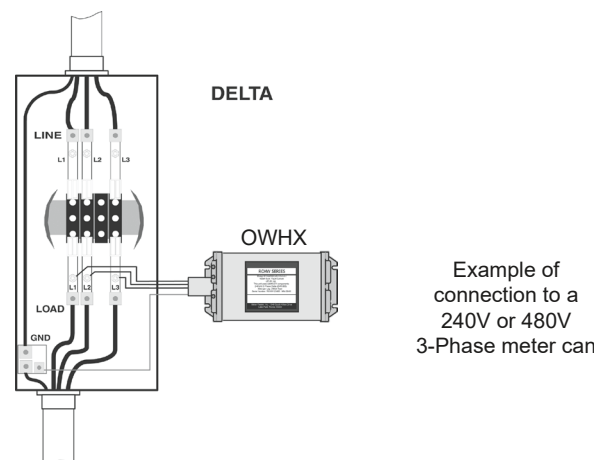
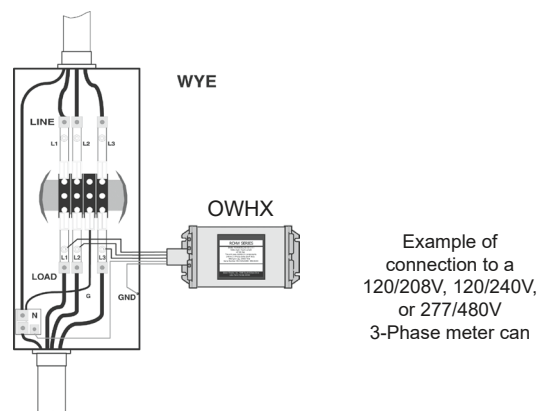
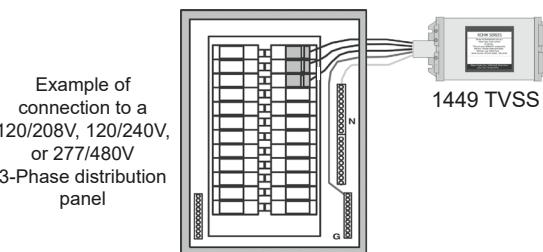
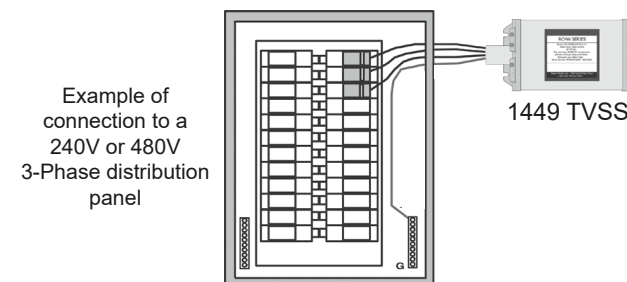

GENERAL

1. This document provides detailed information on how to install and operate the RCHW Series of Surge Protection Devices (SPD)
2. Locate a position to mount the SPD that will minimize the length of connecting wires required. SPD's should be located as close as possible to the AC panel or service area as possible. Mount the units using the mounting holes provided on the enclosure as shown by the illustrations in these instructions.
3. The RCHW Series of protectors are installed and connected in parallel ("shunt") across the AC supply to be protected. Connecting wires do not carry the supply current, only the short duration currents associated with the suppression of a transient event.
4. Identified or indicated leads/wires must be connected exactly with respect to the AC Power feeding the SPD. Failure to do so may result in damage to the device or post a danger to personnel.
5. Incorrect installation may significantly impair the performance of the Surge Protection Device. It is particularly important that all installation procedures and guidelines be followed exactly
6. Installation of this device should only be performed by a qualified licensed installer.
7. Before starting any installation procedures, verify service voltages with an AC voltmeter to ensure that the correct SPD model has been selected.
8. Check to ensure that all connections are correct and secure before energizing.
9. Keep this manual in a safe, dry place for future reference.

INSTALLATION INSTRUCTIONS FOR:

RCHWXXX/120-SO	Single Phase	2 Wire + Gnd
RCHWXXX/120-1O	Single Phase	3 Wire + Gnd
RCHWXXX/120-SP	Split Phase	3 Wire + Gnd
RCHWXXX/120-2P	Single Phase	2 Wire + Gnd
RCHWXXX/240-2P	Single Phase	2 Wire + Gnd
RCHWXXX/120-3W	3 Phase Wye	4 Wire + Gnd
RCHWXXX/220-3W	3 Phase Wye	4 Wire + Gnd
RCHWXXX/230-3W	3 Phase Wye	4 Wire + Gnd
RCHWXXX/240-3W	3 Phase Wye	4 Wire + Gnd
RCHWXXX/120-3H	High Leg Delta	4 Wire + Gnd
RCHWXXX/240-3D	3 Phase Delta	3 Wire + Gnd
RCHWXXX/277-3W	3 Phase Wye	4 Wire + Gnd
RCHWXXX/480-2P	Single Phase	2 Wire + Gnd
RCHWXXX/480-3D	3 Phase Delta	3 Wire + Gnd

ALL RCHW MODELS ARE APPROVED FOR OUTSIDE USE

1. Secondary Surge Arrestors listed to UL OWHX can be directly connected across the load side of the meter can or at the line side of the main breaker. A 30 Amp or 60 Amp disconnect may be used for ease of maintenance.
2. TVSS devices listed to UL 1449 may be fed from the line side of a distribution panel or via a 20 Amp or 30 Amp circuit breaker in a distribution panel for ease of maintenance.
3. Optimize device performance by keeping connecting wires as short and as straight as possible. Plan the wiring path(s) prior to commencing any installation procedure. This will assist in keeping the wire lengths and inductance to a minimum.

IF POSSIBLE, SECURE ALL POWER FROM THE PANEL TO WHICH THE DEVICE IS BEING INSTALLED.

INSURE ALL CONNECTIONS ARE CORRECT AND SECURE BEFORE ENERGIZING SPD.

UNIT DIAGNOSTICS

PHASE LED INDICATORS: When the SPD is securely connected and operating properly, the RED LED(S) will be illuminated. Replacement of the SPD is required if the RED LED(S) are not illuminated. If equipped, the YELLOW LED will illuminate only if there is a high neutral-ground voltage detected.

MAINTENANCE: Check the status of the LED indicator at intervals not to exceed 2 months. If the Phase Indicators are not illuminated the SPD requires replacement.

120/240VAC, Split Phase, 3 Wire + Ground
120VAC, Single Phase, 3 Wire + Ground
120VAC Single Phase, 2 Wire + Ground
240VAC Single Phase, 2 Wire + Ground

1. Deenergize as much as possible prior to installation.
2. Locate the mounting position of the SPD as close as possible to the electrical connection point. The SPD may be connected directly to the load side of the meter socket via spare/additional lugs or through a disconnect, fuse or circuit breaker rated not less than 15 amps.
3. Prepare any supplementary conduit, or other materials for wire routing. Minimize right angles as they will degrade overall SPD performance.
4. Mount the device in your predetermined location next to the panel or equipment to be protected.
5. Connect the Green Ground wire to the system ground.
6. If applicable, connect the White Neutral wire to the neutral bus. Where there is no neutral bus and the SPD is equipped with a white neutral wire, the white neutral wire from the SPD should be connected to ground.
7. Connect the Black Phase wire(s) to each phase.
8. Energize the circuit if applicable. Check that the LED light is on.

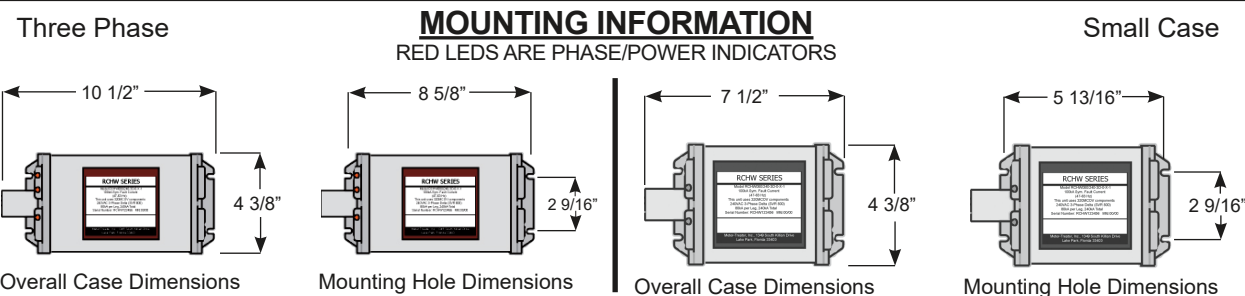
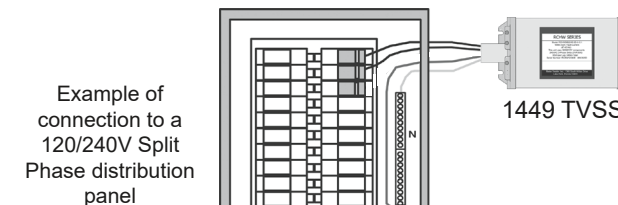

Mount the RCHW Series SPD using the four mounting holes as close as possible to the connections point to the system. Keeping the lead length short will increase the performance of the unit. Connecting conduit should be rated for use in the environment that the SPD is mounted. Splicing wires to gain extra lead length is not advisable as the extra lead length will degrade the performance of the device.

CAUTION: WORKING NEAR EXPOSED LIVE CONDUCTORS IS HAZARDOUS. POWER SHOULD BE SECURED OR APPROPRIATE ELECTRICAL SAFETY EQUIPMENT SHOULD BE USED TO THE GREATEST EXTENT POSSIBLE BEFORE CONNECTING

