

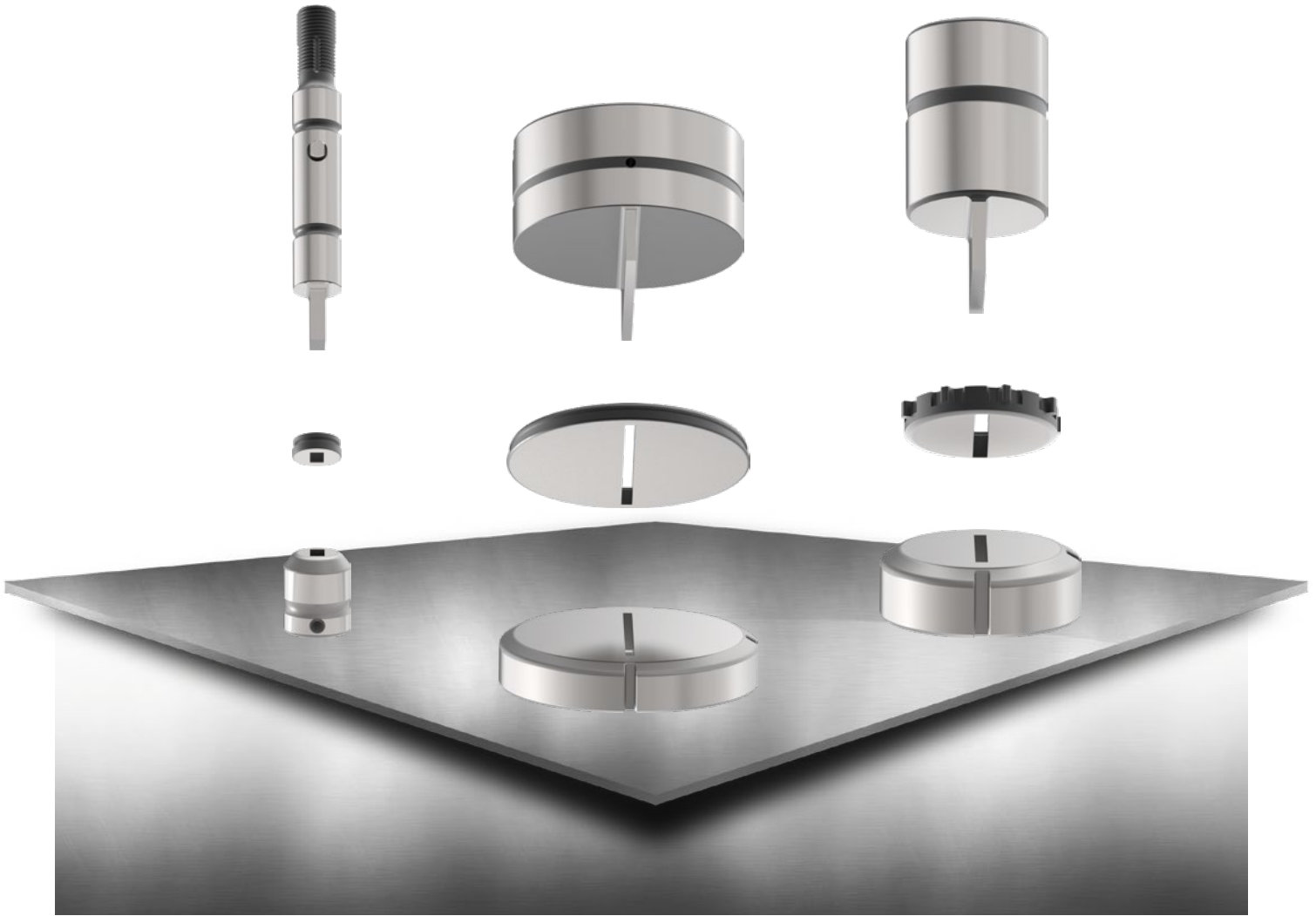

CATALOG INSERTS FOR THIRD PARTY PRODUCTS 03/2023-PASS-US



INSERTS FOR PRIMA POWER® GUIDE ASSEMBLIES

ps:®beta-V2® I Station A.....	page 6
ps:®beta-V2® I Station B.....	page 8
ps:®beta-V2® I Station C.....	page 10
ps:®beta-V2® I Station D.....	page 12
ps:®beta-V2® I Station E.....	page 14

INSERTS FOR MATE® GUIDE ASSEMBLIES

Ultra® TEC®, Ultra® XT™ I Station A.....	page 18
Ultra® TEC®, Ultra® XT™ I Station B.....	page 20
Ultra® TEC® I Station C.....	page 22
Ultra® XT™ I Station C.....	page 24
Ultra® TEC® I Station D.....	page 26
Ultra® XT™ I Station D.....	page 28
Ultra® TEC® I Station E.....	page 30
Ultra® XT™ I Station E.....	page 32

INSERTS FOR WILSON® GUIDE ASSEMBLIES

Serie 90, HP I Station A.....	page 36
Serie 90 WLS, HP WLS I Station A.....	page 38
Serie 90, HP I Station B.....	page 40
Serie 90 WLS, HP WLS I Station B.....	page 42
Serie 80, HP, HP WLS I Station C.....	page 44
Serie 80, HP, HP WLS I Station D.....	page 46
Serie 80, HP, HP WLS I Station E.....	page 48

TECHNICAL INFORMATION

PASS Tool variety I Coatings.....	page 50
-----------------------------------	---------

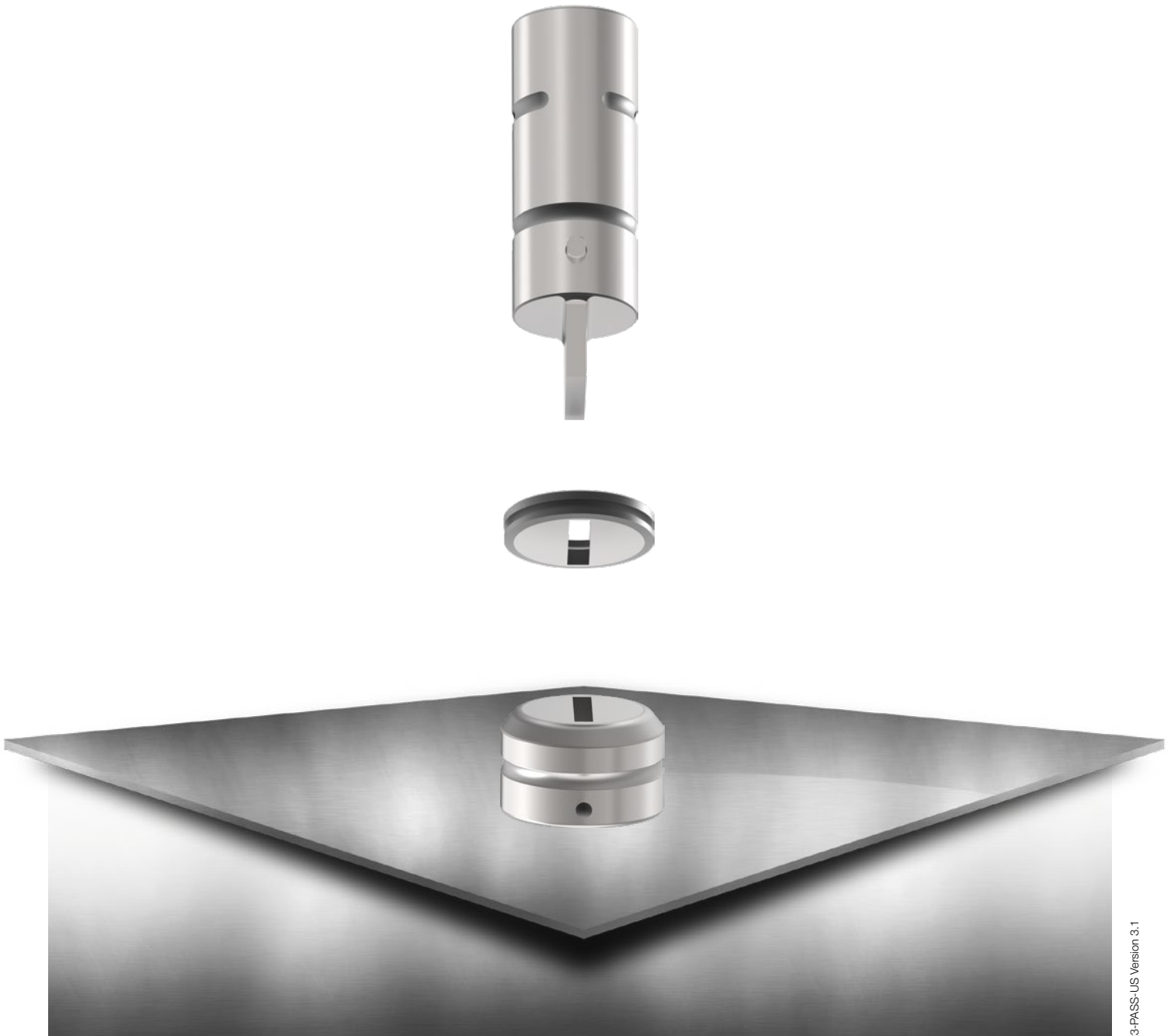

INSERTS FOR PRIMA POWER® GUIDE ASSEMBLIES

Index

ps:®beta-V2® Station A	page 6
ps:®beta-V2® Station B	page 8
ps:®beta-V2® Station C	page 10
ps:®beta-V2® Station D	page 12
ps:®beta-V2® Station E	page 14

ps:®beta-V2® | STATION A

DIAMETER UP TO 12,7 MM

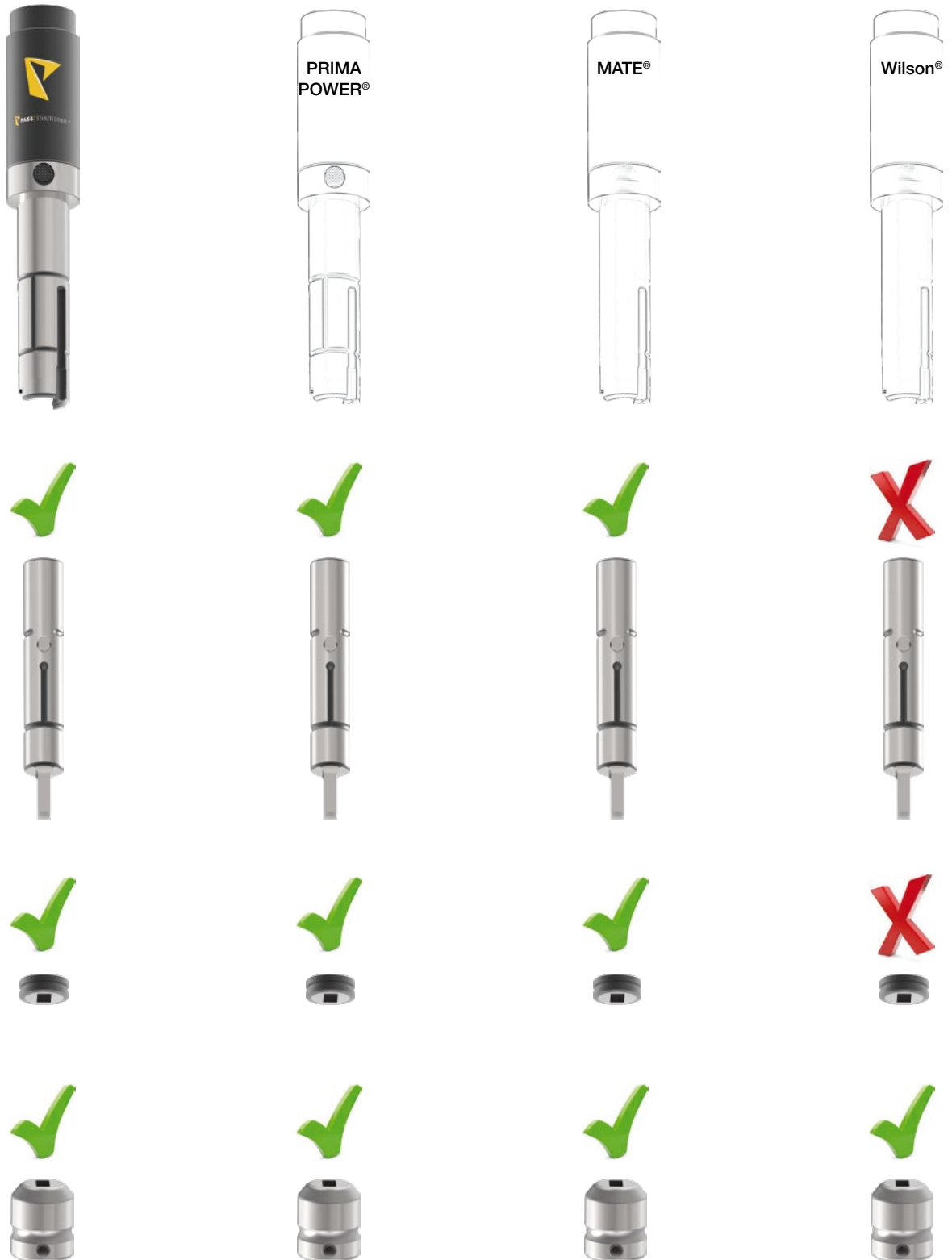

ps:®beta-V2® | STATION A

DIAMETER UP TO 12,7 MM

PART-NO.

PUNCH BODY (H-PM®)		
Round		4020A01
Square		4020A02
Rectangle		4020A03
Oblong		4020A04
O.D. Ground Special Shape		4020A0G
EDM Required Special Shape		4020A0E

STRIPPER		
Round		4040A01
Square		4040A02
Rectangle		4040A03
Oblong		4040A04
O.D. Ground Special Shape		4040A0G
EDM Required Special Shape		4040A0E

DIE (HWS)		
Round		4052A01
Square		4052A02
Rectangle		4052A03
Oblong		4052A04
O.D. Ground Special Shape		4052A0G
EDM Required Special Shape		4052A0E

ADDITIONAL COSTS FOR PUNCH

- TICN coating
- T-MAX coating
- A-MAX coating
- WT-shear
- DOWT-shear
- 2 PT-shear
- 4 PT-shear
- Cutting part under 1,00 mm

ADDITIONAL COSTS FOR DIES

- Reinforced die
- H-PM® Quality
- Additional pin hole

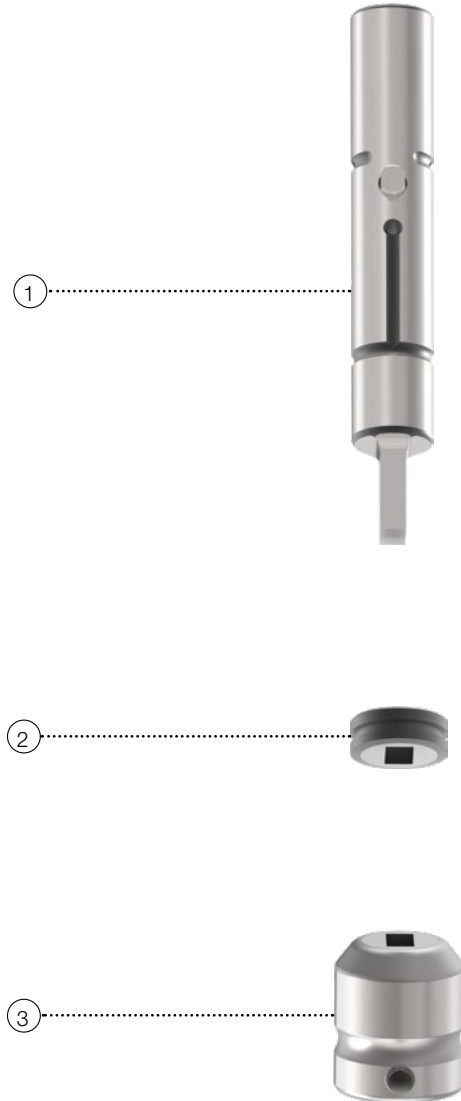

ps:®beta-V2® I STATION B

DIAMETER UP TO 31,75 MM



ps:®beta-V2® | STATION B

DIAMETER UP TO 31,75 MM

PART-NO.

PUNCH BODY (H-PM®)		
Round		4020B01
Square		4020B02
Rectangle		4020B03
Oblong		4020B04
O.D. Ground Special Shape		4020B0G
EDM Required Special Shape		4020B0E

STRIPPER		
Round		4040B01
Square		4040B02
Rectangle		4040B03
Oblong		4040B04
O.D. Ground Special Shape		4040B0G
EDM Required Special Shape		4040B0E

DIE (HWS)		
Round		4052B01
Square		4052B02
Rectangle		4052B03
Oblong		4052B04
O.D. Ground Special Shape		4052B0G
EDM Required Special Shape		4052B0E

ADDITIONAL COSTS FOR PUNCH

- TICN coating
- T-MAX coating
- A-MAX coating
- WT-shear
- DOWT-shear
- 2 PT-shear
- 4 PT-shear
- Cutting part under 1,00 mm

ADDITIONAL COSTS FOR DIES

- Reinforced die
- H-PM® Quality
- Additional pin hole



ps:®beta-V2® | STATION C

DIAMETER UP TO 50,8 MM

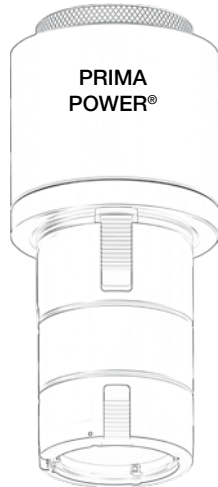

ps:®beta-V2® | STATION C

DIAMETER UP TO 50,8 MM

PART-NO.

PUNCH BODY (H-PM®)		
Round		4020C01
Square		4020C02
Rectangle		4020C03
Oblong		4020C04
O.D. Ground Special Shape		4020C0G
EDM Required Special Shape		4020C0E

STRIPPER		
Round		4040C01
Square		4040C02
Rectangle		4040C03
Oblong		4040C04
O.D. Ground Special Shape		4040C0G
EDM Required Special Shape		4040C0E

DIE (HWS)		
Round		4052C01
Square		4052C02
Rectangle		4052C03
Oblong		4052C04
O.D. Ground Special Shape		4052C0G
EDM Required Special Shape		4052C0E



ADDITIONAL COSTS FOR PUNCH

- TICN coating
- T-MAX coating
- A-MAX coating
- WT-shear
- DOWT-shear
- 2 PT-shear
- 4 PT-shear
- Additional keyway
- Cutting part under 1,00 mm

ADDITIONAL COSTS FOR DIES

- H-PM® Quality
- Additional keyway

ps:®beta-V2® I STATION D

DIAMETER UP TO 88,9 MM

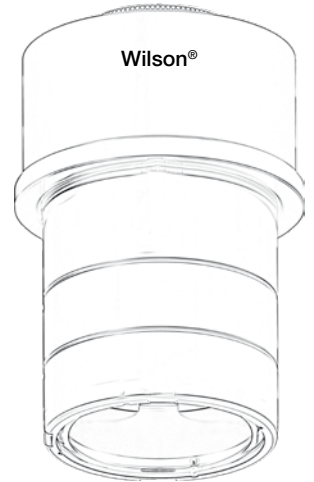
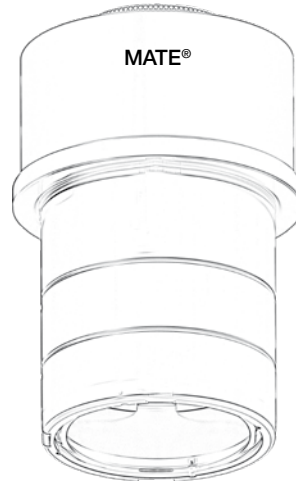
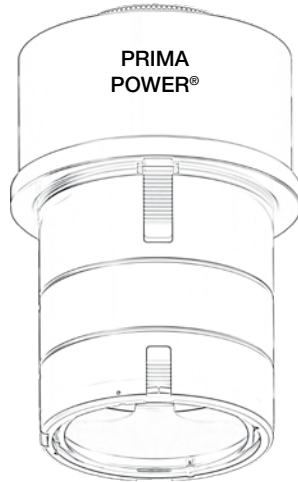

ps:® beta-V2® I STATION D

DIAMETER UP TO 88,9 MM

	PART-NO.
PUNCH BODY (H-PM®)	
Round	4020D01
Square	4020D02
Rectangle	4020D03
Oblong	4020D04
O.D. Ground Special Shape	4020D0G
EDM Required Special Shape	4020D0E
STRIPPER	
Round	4040D01
Square	4040D02
Rectangle	4040D03
Oblong	4040D04
O.D. Ground Special Shape	4040D0G
EDM Required Special Shape	4040D0E
DIE (HWS)	
Round	4052D01
Square	4052D02
Rectangle	4052D03
Oblong	4052D04
O.D. Ground Special Shape	4052D0G
EDM Required Special Shape	4052D0E

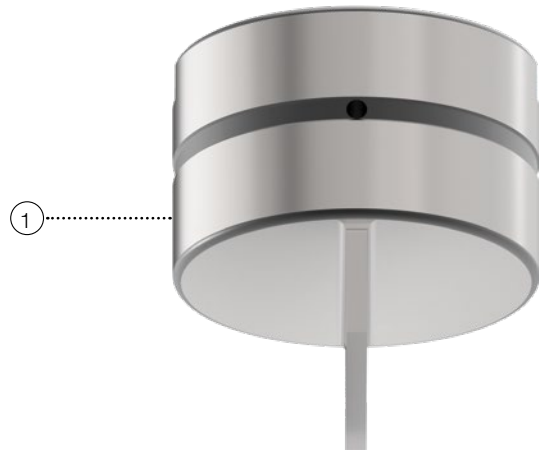

ADDITIONAL COSTS FOR PUNCH

- TICN coating
- T-MAX coating
- A-MAX coating
- WT-shear
- DOWT-shear
- 2 PT-shear
- 4 PT-shear
- Additional keyway
- Cutting part under 1,00 mm

ADDITIONAL COSTS FOR DIES

- H-PM® Quality
- Additional keyway

ps:®beta-V2® I STATION E

DIAMETER UP TO 114,3 MM



ps:®beta-V2® | STATION E

DIAMETER UP TO 114,3 MM

	PART-NO.
PUNCH BODY (H-PM®)	
Round	4020E01
Square	4020E02
Rectangle	4020E03
Oblong	4020E04
O.D. Ground Special Shape	4020E0G
EDM Required Special Shape	4020E0E
STRIPPER	
Round	4040E01
Square	4040E02
Rectangle	4040E03
Oblong	4040E04
O.D. Ground Special Shape	4040E0G
EDM Required Special Shape	4040E0E
DIE (HWS)	
Round	4052E01
Square	4052E02
Rectangle	4052E03
Oblong	4052E04
O.D. Ground Special Shape	4052E0G
EDM Required Special Shape	4052E0E

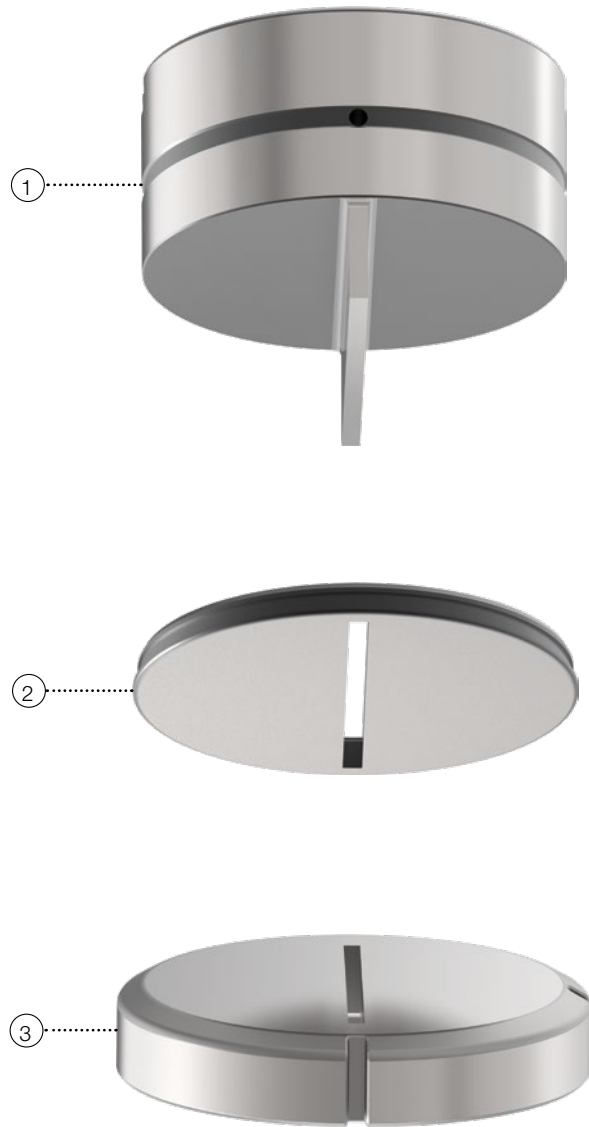

ADDITIONAL COSTS FOR PUNCH

- TICN coating
- T-MAX coating
- A-MAX coating
- WT-shear
- DOWT-shear
- 2 PT-shear
- 4 PT-shear
- Additional keyway
- Cutting part under 1,00 mm

ADDITIONAL COSTS FOR DIES

- H-PM® Quality
- Additional keyway



INSERTS FOR MATE® GUIDE ASSEMBLIES

Index

Ultra® TEC®, Ultra® XT™ Station A	page 18
Ultra® TEC®, Ultra® XT™ Station B	page 20
Ultra® TEC® Station C	page 22
Ultra® XT™ Station C	page 24
Ultra® TEC® Station D	page 26
Ultra® XT™ Station D	page 28
Ultra® TEC® Station E	page 30
Ultra® XT™ Station E	page 32

ULTRA[®] TEC[®], ULTRA[®] XT[™] | STATION A

DIAMETER UP TO 12,7 MM

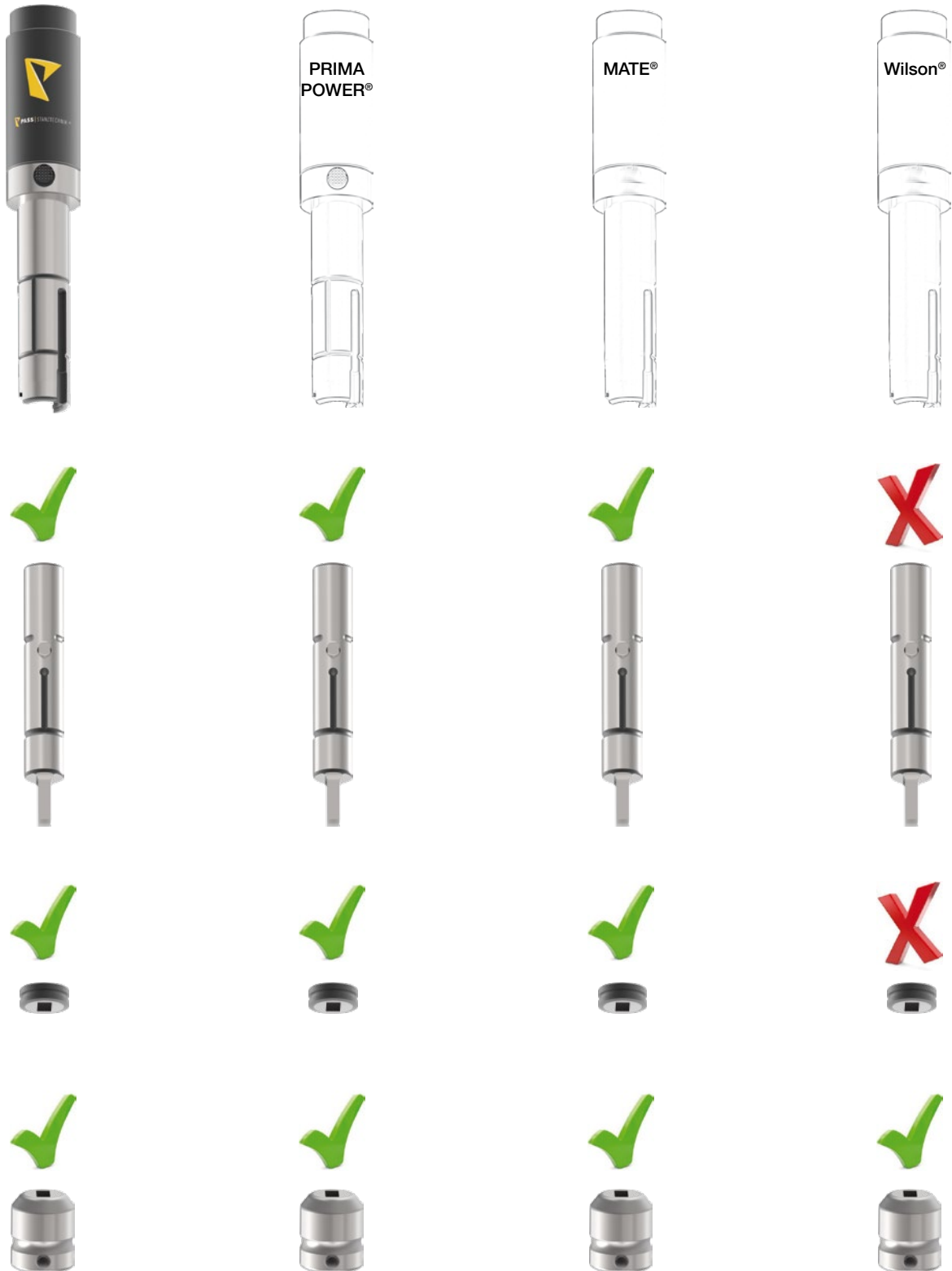

ULTRA[®] TEC[®], ULTRA[®] XT[™] | STATION A

DIAMETER UP TO 12,7 MM

PART-NO.

PUNCH BODY (H-PM [®])		
Round		4020A01
Square		4020A02
Rectangle		4020A03
Oblong		4020A04
O.D. Ground Special Shape		4020A0G
EDM Required Special Shape		4020A0E

STRIPPER		
Round		4040A01
Square		4040A02
Rectangle		4040A03
Oblong		4040A04
O.D. Ground Special Shape		4040A0G
EDM Required Special Shape		4040A0E

DIE (HWS)		
Round		4052A01
Square		4052A02
Rectangle		4052A03
Oblong		4052A04
O.D. Ground Special Shape		4052A0G
EDM Required Special Shape		4052A0E

ADDITIONAL COSTS FOR PUNCH

- TICN coating
- T-MAX coating
- A-MAX coating
- WT-shear
- DOWT-shear
- 2 PT-shear
- 4 PT-shear
- Cutting part under 1,00 mm

ADDITIONAL COSTS FOR DIES

- Reinforced die
- H-PM[®] Quality
- Additional pin hole

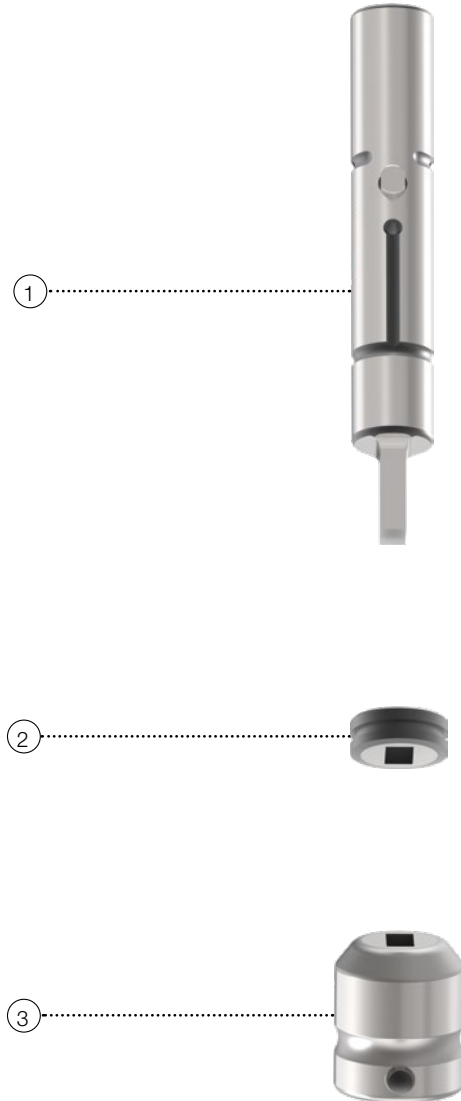

ULTRA® TEC®, ULTRA® XT™ | STATION B

DIAMETER UP TO 31,75 MM



ULTRA[®] TEC[®], ULTRA[®] XT[™] | STATION B

DIAMETER UP TO 31,75 MM

PART-NO.

PUNCH BODY (H-PM [®])		
Round		4020B01
Square		4020B02
Rectangle		4020B03
Oblong		4020B04
O.D. Ground Special Shape		4020B0G
EDM Required Special Shape		4020B0E

STRIPPER		
Round		4040B01
Square		4040B02
Rectangle		4040B03
Oblong		4040B04
O.D. Ground Special Shape		4040B0G
EDM Required Special Shape		4040B0E

DIE (HWS)		
Round		4052B01
Square		4052B02
Rectangle		4052B03
Oblong		4052B04
O.D. Ground Special Shape		4052B0G
EDM Required Special Shape		4052B0E

ADDITIONAL COSTS FOR PUNCH

- TICN coating
- T-MAX coating
- A-MAX coating
- WT-shear
- DOWT-shear
- 2 PT-shear
- 4 PT-shear
- Cutting part under 1,00 mm

ADDITIONAL COSTS FOR DIES

- Reinforced die
- H-PM[®] Quality
- Additional pin hole



ULTRA® TEC® | STATION C

DIAMETER UP TO 50,8 MM



ULTRA® TEC® I STATION C

DIAMETER UP TO 50,8 MM

		PART-NO.
PUNCH BODY (H-PM®)		
	Round	4020C01
	Square	4020C02
	Rectangle	4020C03
	Oblong	4020C04
	O.D. Ground Special Shape	4020C0G
	EDM Required Special Shape	4020C0E
STRIPPER		
	Round	461C11
	Square	461C12
	Rectangle	461C13
	Oblong	461C14
	O.D. Ground Special Shape	461C1G
	EDM Required Special Shape	461C1E
DIE (HWS)		
	Round	4052C01
	Square	4052C02
	Rectangle	4052C03
	Oblong	4052C04
	O.D. Ground Special Shape	4052C0G
	EDM Required Special Shape	4052C0E

ADDITIONAL COSTS FOR PUNCH

- TICN coating
- T-MAX coating
- A-MAX coating
- WT-shear
- DOWT-shear
- 2 PT-shear
- 4 PT-shear
- Cutting part under 1,00 mm

ADDITIONAL COSTS FOR DIES

- H-PM® Quality
- Additional pin hole

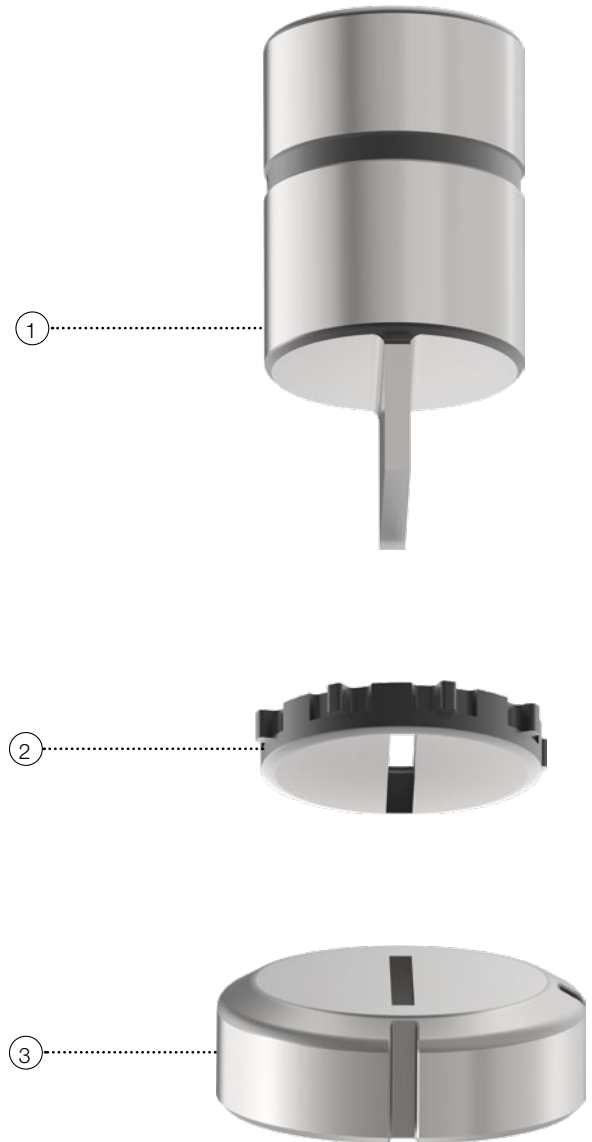

ULTRA® XT™ | STATION C

DIAMETER UP TO 50,8 MM



ULTRA® XT™ | STATION C

DIAMETER UP TO 50,8 MM

	PART-NO.
PUNCH BODY (H-PM®)	
Round	4020C01
Square	4020C02
Rectangle	4020C03
Oblong	4020C04
O.D. Ground Special Shape	4020C0G
EDM Required Special Shape	4020C0E
STRIPPER	
Round	4032C01
Square	4032C02
Rectangle	4032C03
Oblong	4032C04
O.D. Ground Special Shape	4032C0G
EDM Required Special Shape	4032C0E
DIE (HWS)	
Round	4052C01
Square	4052C02
Rectangle	4052C03
Oblong	4052C04
O.D. Ground Special Shape	4052C0G
EDM Required Special Shape	4052C0E

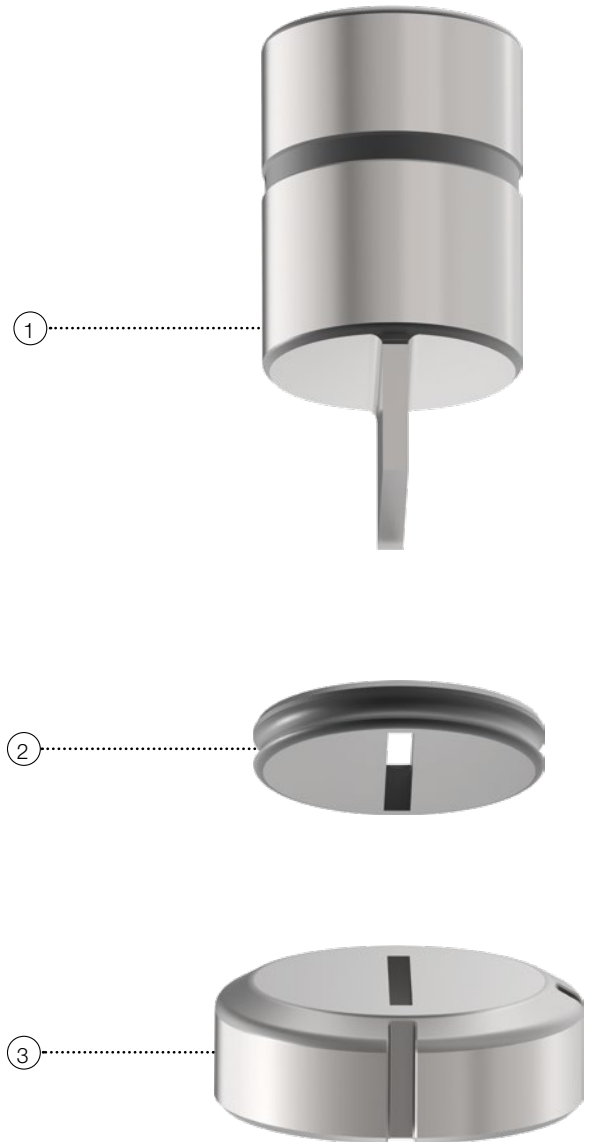

ADDITIONAL COSTS FOR PUNCH

- TICN coating
- T-MAX coating
- A-MAX coating
- WT-shear
- DOWT-shear
- 2 PT-shear
- 4 PT-shear
- Additional keyway
- Cutting part under 1,00 mm

ADDITIONAL COSTS FOR DIES

- H-PM® Quality
- Additional pin hole

ULTRA® TEC® | STATION D

DIAMETER UP TO 88,9 MM



ULTRA® TEC® I STATION D

DIAMETER UP TO 88,9 MM

	PART-NO.
PUNCH BODY (H-PM®)	
Round	4020D01
Square	4020D02
Rectangle	4020D03
Oblong	4020D04
O.D. Ground Special Shape	4020D0G
EDM Required Special Shape	4020D0E
STRIPPER	
Round	461D11
Square	461D12
Rectangle	461D13
Oblong	461D14
O.D. Ground Special Shape	461D1G
EDM Required Special Shape	461D1E
DIE (HWS)	
Round	4052D01
Square	4052D02
Rectangle	4052D03
Oblong	4052D04
O.D. Ground Special Shape	4052D0G
EDM Required Special Shape	4052D0E

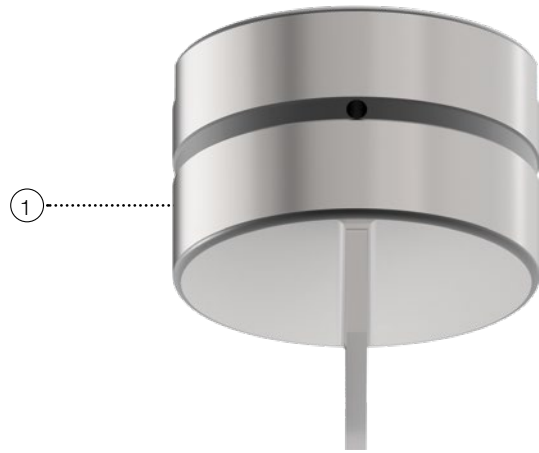

ADDITIONAL COSTS FOR PUNCH

- TICN coating
- T-MAX coating
- A-MAX coating
- WT-shear
- DOWT-shear
- 2 PT-shear
- 4 PT-shear
- Additional keyway
- Cutting part under 1,00 mm

ADDITIONAL COSTS FOR DIES

- H-PM® Quality
- Additional keyway

ULTRA® XT™ | STATION D

DIAMETER UP TO 88,9 MM



ULTRA[®] XT[™] | STATION D

DIAMETER UP TO 88,9 MM

PART-NO.

PUNCH BODY (H-PM [®])		
Round		4020D01
Square		4020D02
Rectangle		4020D03
Oblong		4020D04
O.D. Ground Special Shape		4020D0G
EDM Required Special Shape		4020D0E

STRIPPER		
Round		4032D01
Square		4032D02
Rectangle		4032D03
Oblong		4032D04
O.D. Ground Special Shape		4032D0G
EDM Required Special Shape		4032D0E

DIE (HWS)		
Round		4052D01
Square		4052D02
Rectangle		4052D03
Oblong		4052D04
O.D. Ground Special Shape		4052D0G
EDM Required Special Shape		4052D0E

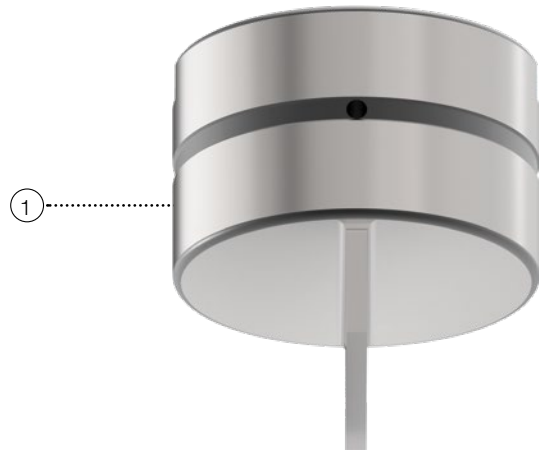

ADDITIONAL COSTS FOR PUNCH

- TICN coating
- T-MAX coating
- A-MAX coating
- WT-shear
- DOWT-shear
- 2 PT-shear
- 4 PT-shear
- Additional keyway
- Cutting part under 1,00 mm

ADDITIONAL COSTS FOR DIES

- H-PM[®] Quality
- Additional keyway

ULTRA® TEC® | STATION E

DIAMETER UP TO 114,3 MM



ULTRA[®] TEC[®] | STATION E

DIAMETER UP TO 114,3 MM

	PART-NO.
PUNCH BODY (H-PM[®])	
Round	4020E01
Square	4020E02
Rectangle	4020E03
Oblong	4020E04
O.D. Ground Special Shape	4020E0G
EDM Required Special Shape	4020E0E
STRIPPER	
Round	461E11
Square	461E12
Rectangle	461E13
Oblong	461E14
O.D. Ground Special Shape	461E1G
EDM Required Special Shape	461E1E
DIE (HWS)	
Round	4052E01
Square	4052E02
Rectangle	4052E03
Oblong	4052E04
O.D. Ground Special Shape	4052E0G
EDM Required Special Shape	4052E0E

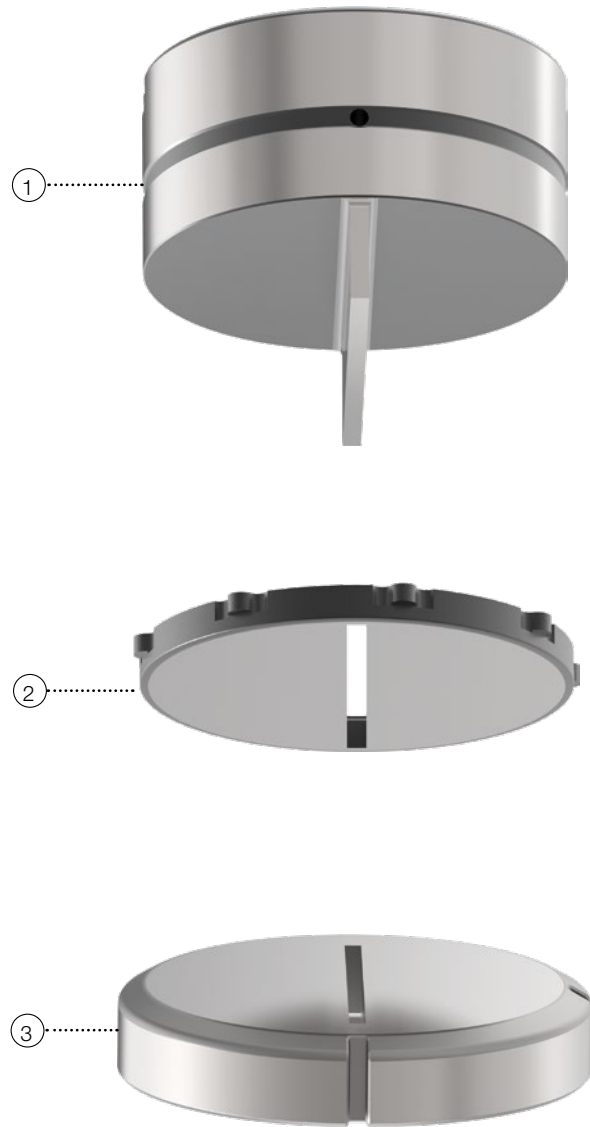

ADDITIONAL COSTS FOR PUNCH

- TICN coating
- T-MAX coating
- A-MAX coating
- WT-shear
- DOWT-shear
- 2 PT-shear
- 4 PT-shear
- Additional keyway
- Cutting part under 1,00 mm

ADDITIONAL COSTS FOR DIES

- H-PM[®] Quality
- Additional keyway

ULTRA® XT™ | STATION E

DIAMETER UP TO 114,3 MM



ULTRA[®] XT[™] | STATION E

DIAMETER UP TO 114,3 MM

	PART-NO.
PUNCH BODY (H-PM[®])	
Round	4020E01
Square	4020E02
Rectangle	4020E03
Oblong	4020E04
O.D. Ground Special Shape	4020E0G
EDM Required Special Shape	4020E0E
STRIPPER	
Round	4032E01
Square	4032E02
Rectangle	4032E03
Oblong	4032E04
O.D. Ground Special Shape	4032E0G
EDM Required Special Shape	4032E0E
DIE (HWS)	
Round	4052E01
Square	4052E02
Rectangle	4052E03
Oblong	4052E04
O.D. Ground Special Shape	4052E0G
EDM Required Special Shape	4052E0E

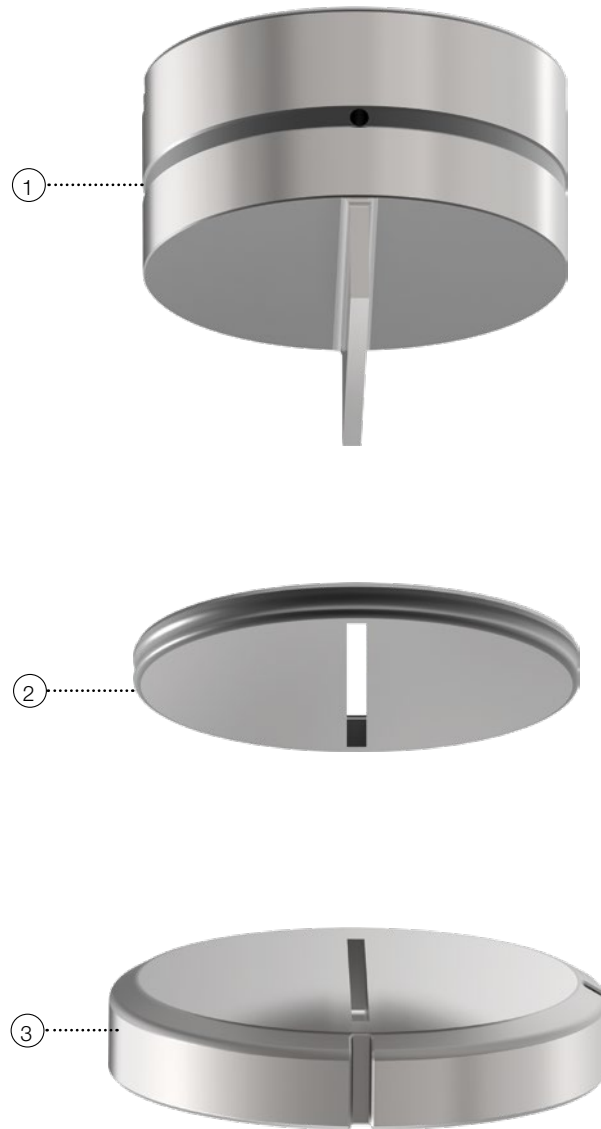

ADDITIONAL COSTS FOR PUNCH

- TICN coating
- T-MAX coating
- A-MAX coating
- WT-shear
- DOWT-shear
- 2 PT-shear
- 4 PT-shear
- Additional keyway
- Cutting part under 1,00 mm

ADDITIONAL COSTS FOR DIES

- H-PM[®] Quality
- Additional keyway



INSERTS FOR WILSON® GUIDE ASSEMBLIES

Index

Serie 90, HP I Station A	page 36
Serie 90 WLS, HP WLS I Station A	page 38
Serie 90, HP I Station B	page 40
Serie 90 WLS, HP WLS I Station B	page 42
Serie 80, HP, HP WLS I Station C	page 44
Serie 80, HP, HP WLS I Station D	page 46
Serie 80, HP, HP WLS I Station E	page 48

SERIE 90, HP I STATION A

DIAMETER UP TO 12,7 MM

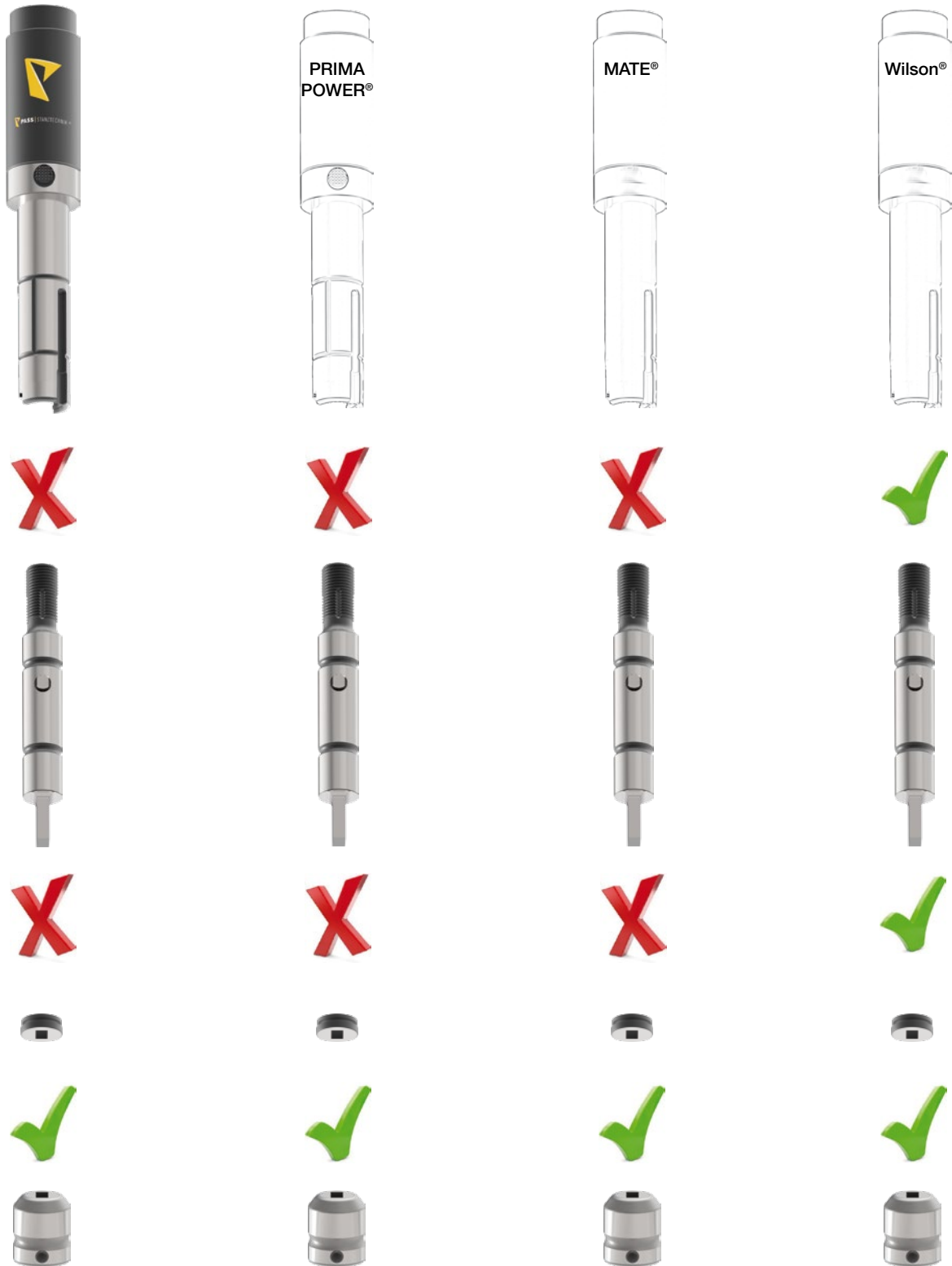

SERIE 90, HP I STATION A

DIAMETER UP TO 12,7 MM

	PART-NO.
PUNCH (H-PM®)	
Round	422A21
Square	422A22
Rectangle	422A23
Oblong	422A24
O.D. Ground Special Shape	422A2G
EDM Required Special Shape	422A2E
STRIPPER	
Round	461A21
Square	461A22
Rectangle	461A23
Oblong	461A24
O.D. Ground Special Shape	461A2G
EDM Required Special Shape	461A2E
DIE (HWS)	
Round	4052A01
Square	4052A02
Rectangle	4052A03
Oblong	4052A04
O.D. Ground Special Shape	4052A0G
EDM Required Special Shape	4052A0E

ADDITIONAL COSTS FOR PUNCHES

- TICN coating
- T-MAX coating
- A-MAX coating
- WT-shear
- DOWT-shear
- 2 PT-shear
- 4 PT-shear

ADDITIONAL COSTS FOR DIES

- Reinforced version
- H-PM® Quality

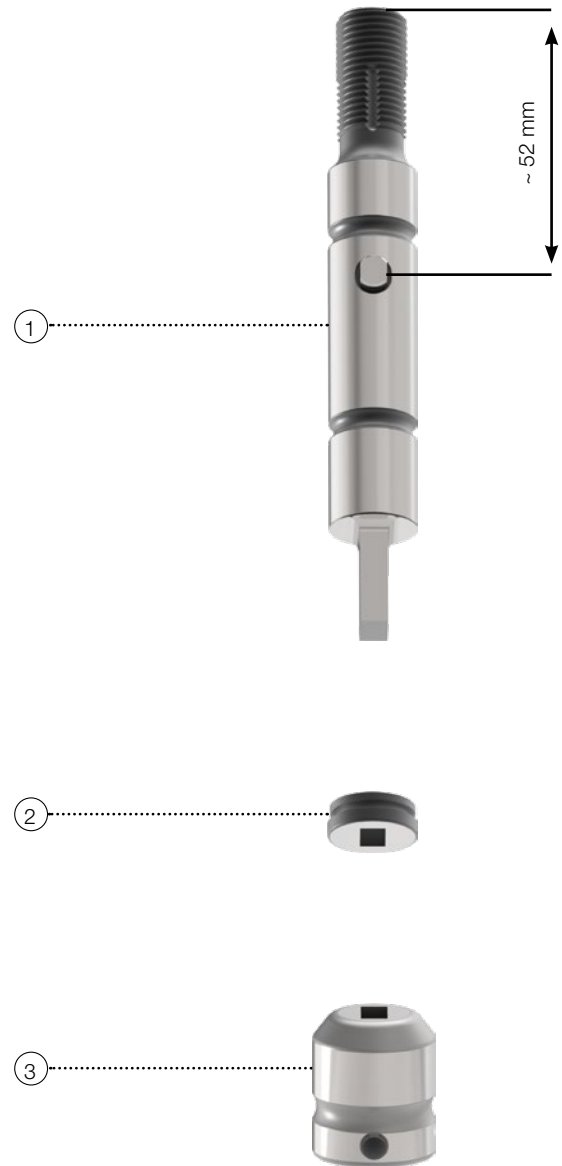

SERIE 90 WLS, HP WLS I STATION A

DIAMETER UP TO 12,7 MM

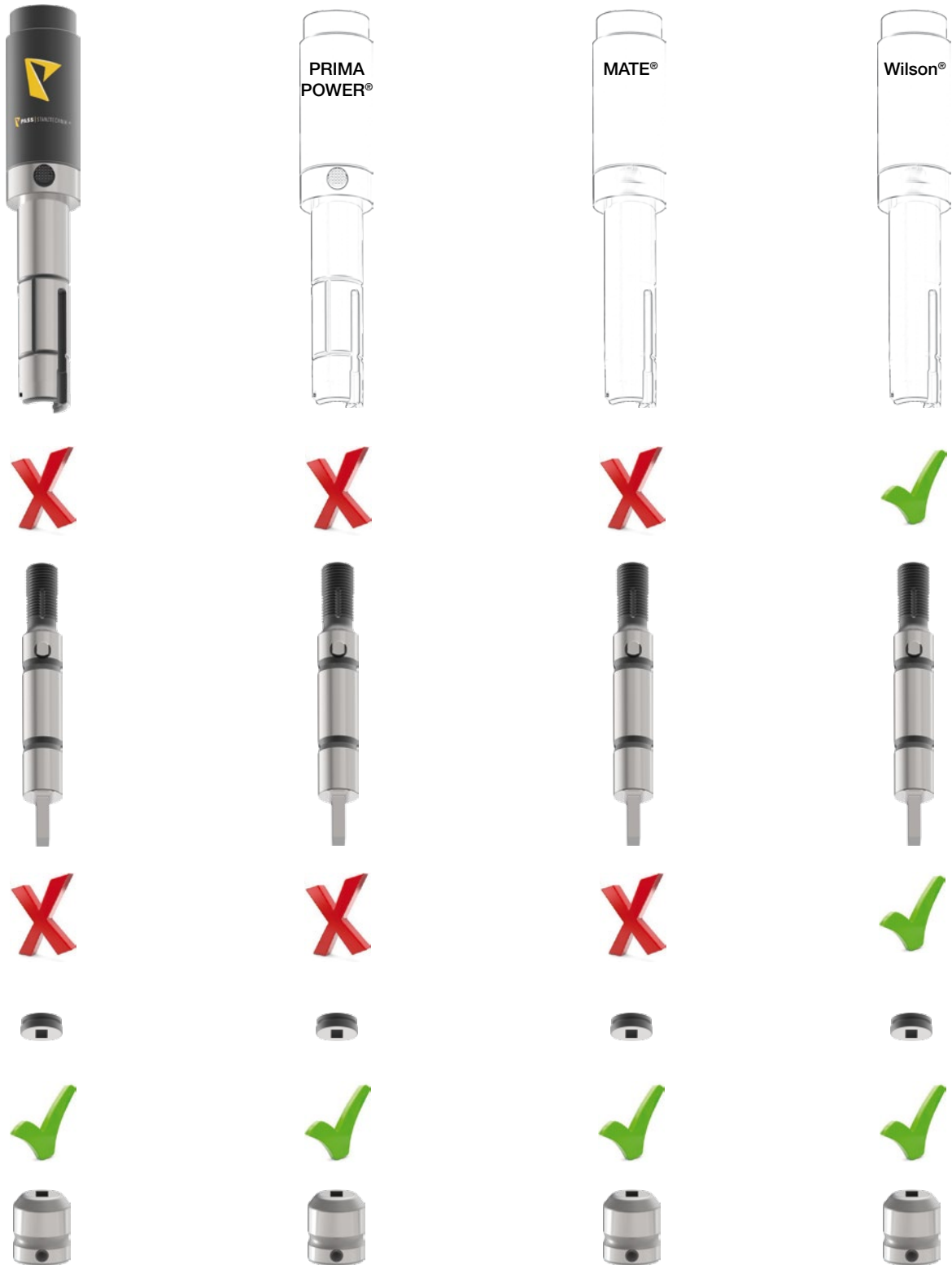

SERIE 90 WLS, HP WLS | STATION A

DIAMETER UP TO 12,7 MM

	PART-NO.
PUNCH (H-PM®)	
Round	422A41
Square	422A42
Rectangle	422A43
Oblong	422A44
O.D. Ground Special Shape	422A4G
EDM Required Special Shape	422A4E
STRIPPER	
Round	461A41
Square	461A42
Rectangle	461A43
Oblong	461A44
O.D. Ground Special Shape	461A4G
EDM Required Special Shape	461A4E
DIE (HWS)	
Round	4052A01
Square	4052A02
Rectangle	4052A03
Oblong	4052A04
O.D. Ground Special Shape	4052A0G
EDM Required Special Shape	4052A0E

ADDITIONAL COSTS FOR PUNCHES

- TICN coating
- T-MAX coating
- A-MAX coating
- WT-shear
- DOWT-shear
- 2 PT-shear
- 4 PT-shear

ADDITIONAL COSTS FOR DIES

- Reinforced version
- H-PM® Quality

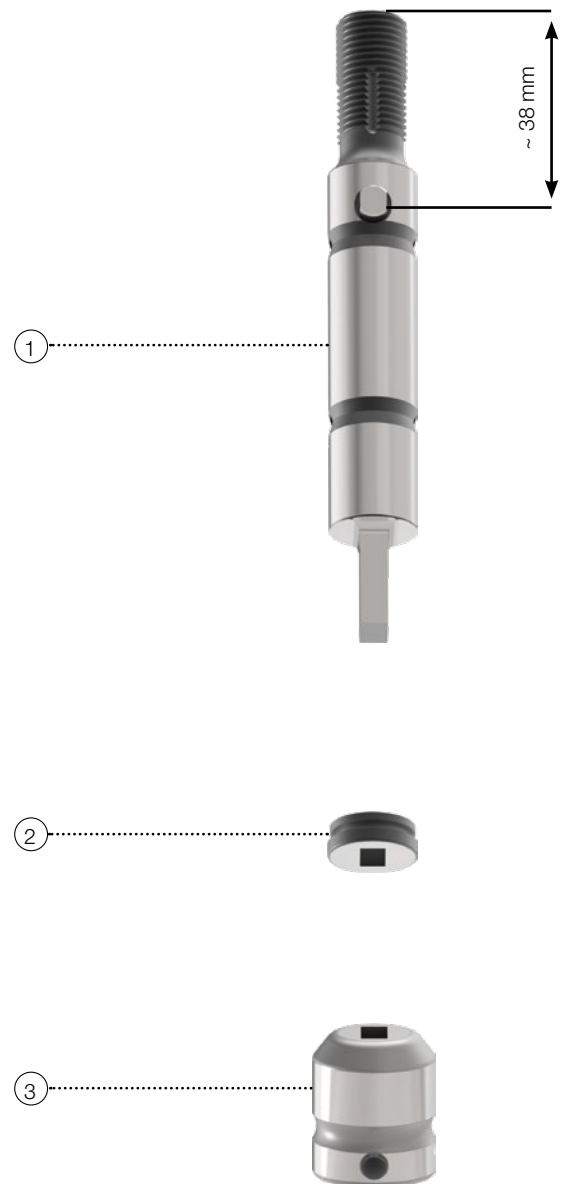

SERIE 90, HP I STATION B

DIAMETER UP TO 31,75 MM



SERIE 90, HP I STATION B

DIAMETER UP TO 31,75 MM

	PART-NO.
PUNCH (H-PM®)	
Round	422B21
Square	422B22
Rectangle	422B23
Oblong	422B24
O.D. Ground Special Shape	422B2G
EDM Required Special Shape	422B2E
STRIPPER	
Round	461B21
Square	461B22
Rectangle	461B23
Oblong	461B24
O.D. Ground Special Shape	461B2G
EDM Required Special Shape	461B2E
DIE (HWS)	
Round	4052B01
Square	4052B02
Rectangle	4052B03
Oblong	4052B04
O.D. Ground Special Shape	4052B0G
EDM Required Special Shape	4052B0E

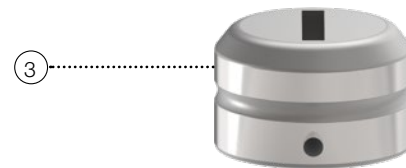
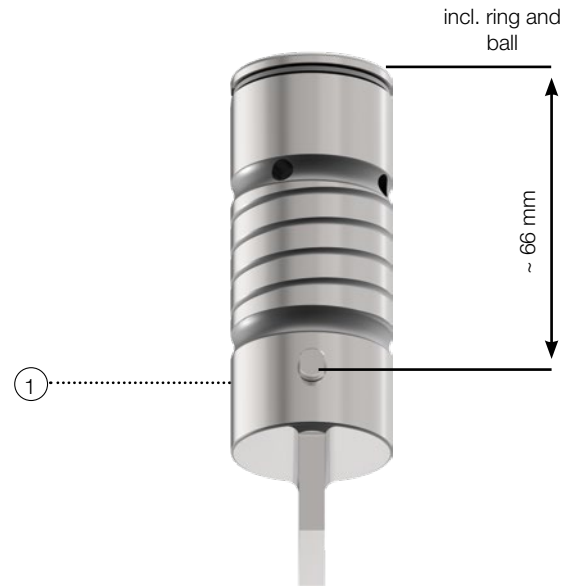

ADDITIONAL COSTS FOR PUNCHES

- TICN coating
- T-MAX coating
- A-MAX coating
- WT-shear
- DOWT-shear
- 2 PT-shear
- 4 PT-shear

ADDITIONAL COSTS FOR DIES

- Reinforced version
- H-PM® Quality

SERIE 90 WLS, HP WLS I STATION B

DIAMETER UP TO 31,75 MM



SERIE 90 WLS, HP WLS I STATION B

DIAMETER UP TO 31,75 MM

	PART-NO.
PUNCH (H-PM®)	
Round	422B41
Square	422B42
Rectangle	422B43
Oblong	422B44
O.D. Ground Special Shape	422B4G
EDM Required Special Shape	422B4E

STRIPPER	
Round	461B41
Square	461B42
Rectangle	461B43
Oblong	461B44
O.D. Ground Special Shape	461B4G
EDM Required Special Shape	461B4E

DIE (HWS)	
Round	4052B01
Square	4052B02
Rectangle	4052B03
Oblong	4052B04
O.D. Ground Special Shape	4052B0G
EDM Required Special Shape	4052B0E

ADDITIONAL COSTS FOR PUNCHES

- TICN coating
- T-MAX coating
- A-MAX coating
- WT-shear
- DOWT-shear
- 2 PT-shear
- 4 PT-shear

ADDITIONAL COSTS FOR DIES

- Reinforced version
- H-PM® Quality

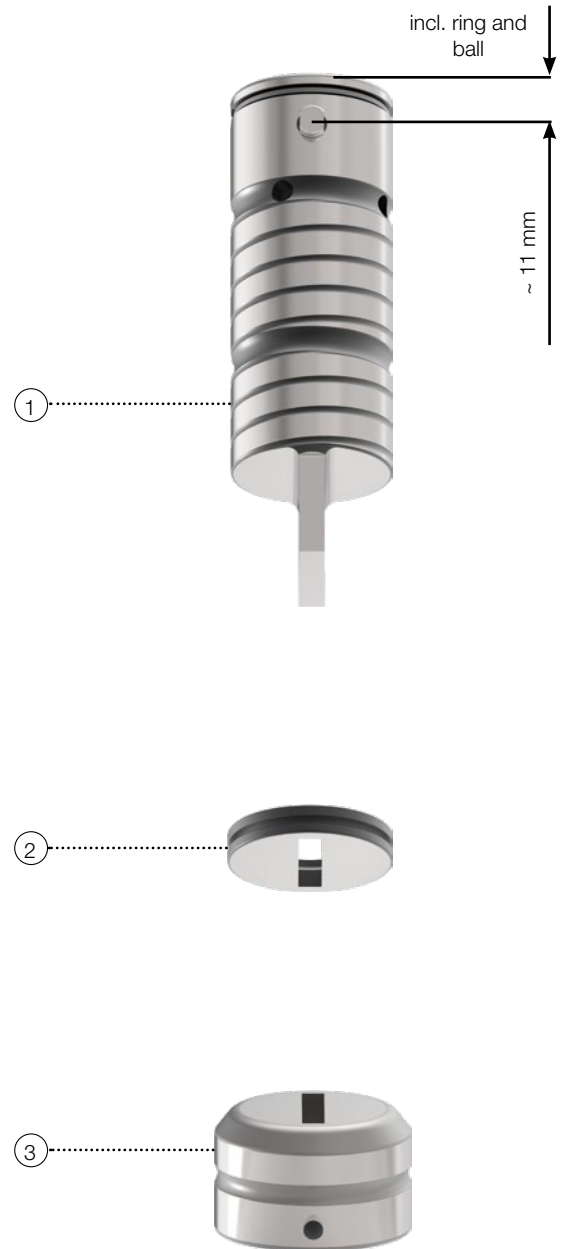

SERIE 80, HP, HP WLS I STATION C

DIAMETER UP TO 50,8 MM



Adapter set for punch (code 635448) possible
- price on request -

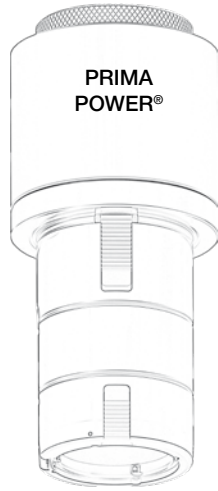

SERIE 80, HP, HP WLS I STATION C

DIAMETER UP TO 50,8 MM

	PART-NO.
PUNCH (H-PM®)	
Round	422C21
Square	422C22
Rectangle	422C23
Oblong	422C24
O.D. Ground Special Shape	422C2G
EDM Required Special Shape	422C2E
STRIPPER	
Round	461C21
Square	461C22
Rectangle	461C23
Oblong	461C24
O.D. Ground Special Shape	461C2G
EDM Required Special Shape	461C2E
DIE (HWS)	
Round	4052C01
Square	4052C02
Rectangle	4052C03
Oblong	4052C04
O.D. Ground Special Shape	4052C0G
EDM Required Special Shape	4052C0E

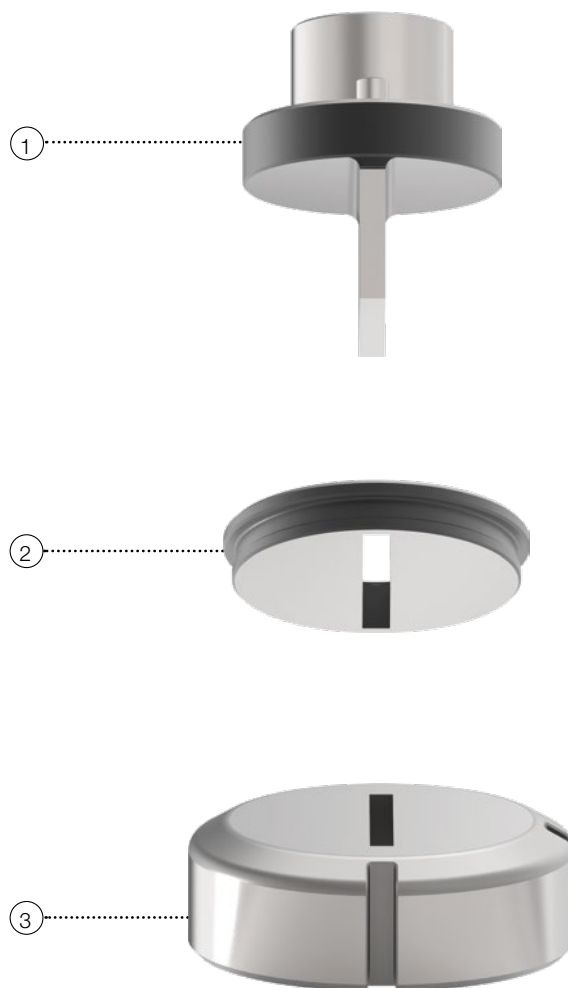

ADDITIONAL COSTS FOR PUNCHES

- TICN coating
- T-MAX coating
- A-MAX coating
- WT-shear
- DOWT-shear
- 2 PT-shear
- 4 PT-shear

ADDITIONAL COSTS FOR DIES

- H-PM® Quality

SERIE 80, HP, HP WLS I STATION D

DIAMETER UP TO 88,9 MM



Adapter set for punch (code 667636) possible
- price on request -

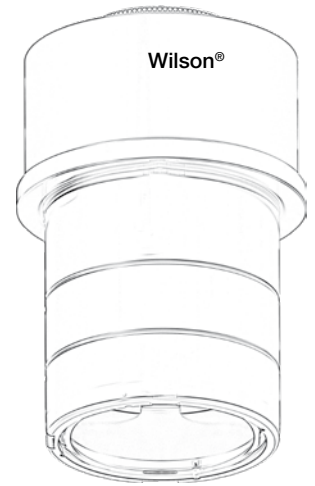
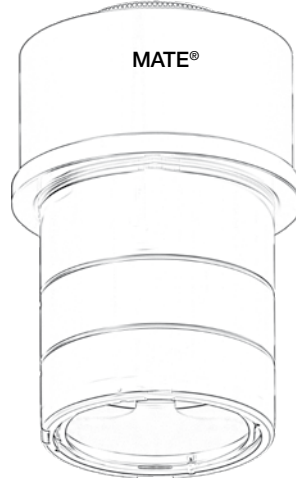
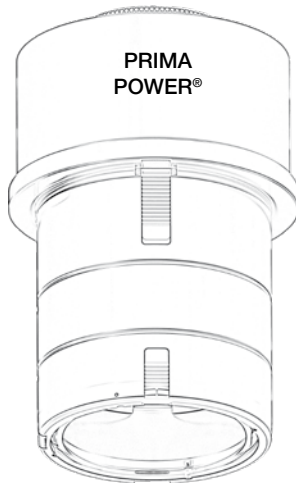

SERIE 80, HP, HP WLS I STATION D

DIAMETER UP TO 88,9 MM

	PART-NO.
PUNCH (H-PM®)	
Round	422D21
Square	422D22
Rectangle	422D23
Oblong	422D24
O.D. Ground Special Shape	422D2G
EDM Required Special Shape	422D2E
STRIPPER	
Round	461D21
Square	461D22
Rectangle	461D23
Oblong	461D24
O.D. Ground Special Shape	461D2G
EDM Required Special Shape	461D2E
DIE (HWS)	
Round	4052D01
Square	4052D02
Rectangle	4052D03
Oblong	4052D04
O.D. Ground Special Shape	4052D0G
EDM Required Special Shape	4052D0E



ADDITIONAL COSTS FOR PUNCHES

- TICN coating
- T-MAX coating
- A-MAX coating
- WT-shear
- DOWT-shear
- 2 PT-shear
- 4 PT-shear

ADDITIONAL COSTS FOR DIES

- H-PM® Quality

SERIE 80, HP, HP WLS I STATION E

DIAMETER UP TO 114,3 MM



Adapter set for punch on request

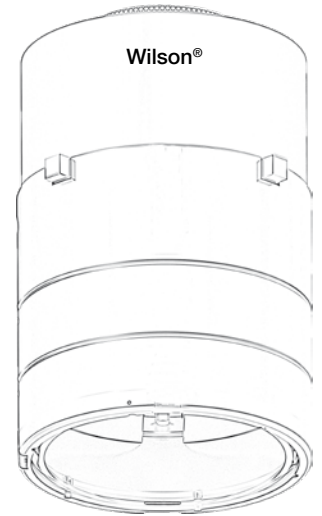
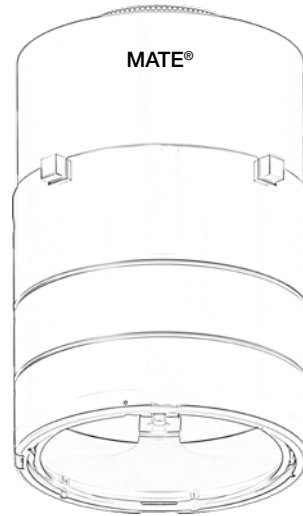
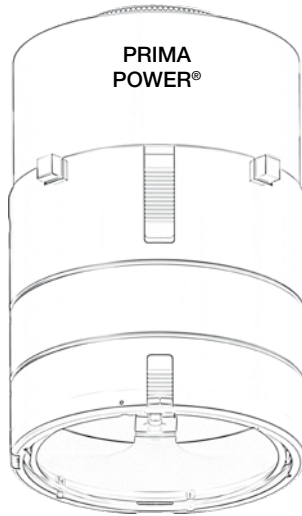

SERIE 80, HP, HP WLS | STATION E

DIAMETER UP TO 114,3 MM

PART-NO.

PUNCH (H-PM®)		
Round	422E21	
Square	422E22	
Rectangle	422E23	
Oblong	422E24	
O.D. Ground Special Shape	422E2G	
EDM Required Special Shape	422E2E	

STRIPPER		
Round	461E21	
Square	461E22	
Rectangle	461E23	
Oblong	461E24	
O.D. Ground Special Shape	461E2G	
EDM Required Special Shape	461E2E	

DIE (HWS)		
Round	4052E01	
Square	4052E02	
Rectangle	4052E03	
Oblong	4052E04	
O.D. Ground Special Shape	4052E0G	
EDM Required Special Shape	4052E0E	

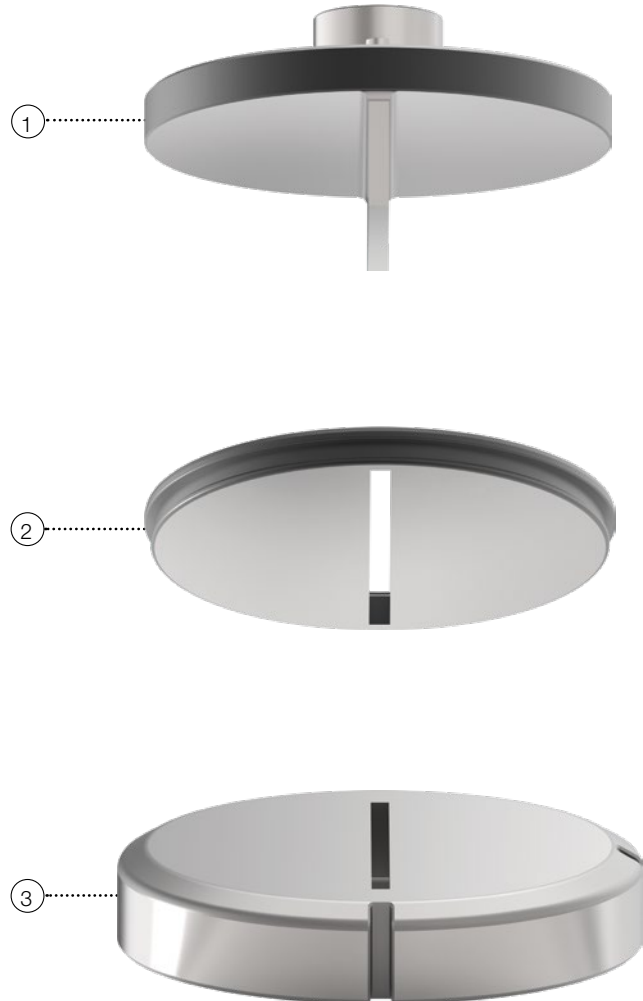

ADDITIONAL COSTS FOR PUNCHES

- TICN coating
- T-MAX coating
- A-MAX coating
- WT-shear
- DOWT-shear
- 2 PT-shear
- 4 PT-shear

ADDITIONAL COSTS FOR DIES

- H-PM® Quality

PASS TOOL VARIETY | COATINGS

HWS

HWS tools are made of a secondary hardened cold work steel with superior toughness. This type of steel is especially suitable for dies.

Advantage for customer:

- excellent cost in accordance to performance

H-PM®

H-PM® tools are produced with steel made on powder-metallurgical base with a high degree of purity.

This guarantees a segregation-free uniform microstructure in the complete cross-section of the tool.

Advantage for customer:

- excellent cost in accordance to performance
- good stability for edges by increased toughness
- high tool lifetime due to the uniform microstructure
- increased current hit-flex-capability; suitable as an excellent base for dies

H-PM® tools are produced with steel made on powder-metallurgical base with a high degree of purity to fulfill the highest punching demands.

Furthermore we attach great importance to a high quality hardening process by repeated tempering and deep-freeze subsequently.

This process guarantees an extremely high hardness with an outstanding wear resistance of our punching tools.

Associated with modern production methods (grinding of the cutting edges with special grinding wheels) we can ensure that the wide range of different sheet qualities can be punched up to 1.600 N/mm² – no matter if it concerns mild alloyed aluminium, mild steel, stainless steel or spring band steel.

A high punch hardness as well as an excellent grinding surface are important in order to counteract the problem with edge build-up.

Tests show us that the well-known TiCN coating is a good coating to increase the lifetime (especially working with stainless steel). However, the problem of material buildup on the edges have not really been counteracted.

Built-up edges are known especially when working with

- galvanised steel
- aluminium sheets

After specialized tests at PASS Tooling the below mentioned coatings turned out to be the most successful coatings:

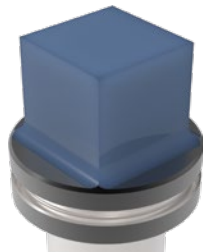

TiCN

for working with stainless steel

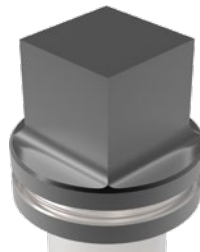

A-MAX

for dry processing with aluminium sheet



T-MAX

for working with galvanised sheet / zincor

SALVAGNINI | **THICK TURRET** | **TRUMPF**



5170 N 126th St
Butler, WI 53007 | USA

WEB: www.passtooling.com
EMAIL: sales@passtooling.com

PHONE: 262-307-2209