

200 & 300 GALLON 3 POINT HITCH LEVELING BOOM 12 ROW

Van's has made our Hydraulic Leveling Boom System available on our 200 and 300 Gallon 3 Point Hitch Sprayer Line. This Boom Leveling option is desirable in areas where uneven ground and terraced fields are encountered.



Since VAN'S EQUIPMENT'S beginnings we have used a generic owners manual. It was just too costly to have printed and keep on hand owner manuals specific to each size and type sprayer we manufacture.

We now have the technology in house to create sprayer specific manuals and to print them only as needed. We think we have made a good beginning, but these manuals are still in the development stage. At this point we would appreciate the input of our end user customer and our dealers as to how we can make these manuals more useful and user friendly.

This is the prototype manual. Please look over the manual and give us your input.

CALL VANS EQUIPMENT AT 1-800-765-1101 AND ASK FOR CRAIG

We appreciate your input on these manuals.

Thanks Vans Equipment

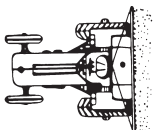

van's

EQUIPMENT COMPANY

P.O. BOX 3157 • 2169 SYLVESTER HIGHWAY • MOULTRIE, GEORGIA 31776-3157

We Appreciate You and Your Business!

(229) 985-1101

**VAN'S EQUIPMENT
BUILT FOR FARMING INTEGRITY**

WHEN SELECTING EQUIPMENT FOR FARMING THE NAME VAN'S means availability, reliability, and proven superiority. Maintaining a close association with farming customers has resulted in equipment design and manufacturing philosophy that reflects the exacting requirements of our customers.

Van's Equipment Company, Inc. appreciates your purchase of a new spray unit. This unit, is designed to give years of service with proper care. The following pages will be helpful in set-up and maintenance of your new unit.

PLEASE READ THIS MANUAL CAREFULLY BEFORE INITIAL START-UP IS ATTEMPTED.

**WE APPRECIATE YOU
AND YOUR BUSINESS**

INDEX

PAGE NO.....	DESCRIPTION
2.....	Model Description and Overview
3.....	Main Breakdown
4.....	Boom and Center Section Breakdown
5.....	Plumbing Breakdown,(Diaphragm pump,Manual valve PTO drive
6-7...	Parts List,(Main,Boom & Center Section,PlumbingDiaphragm pump,Manual valve PTO dr.
8.....	Plumbing Breakdown,(Diaphragm pump,Electric valve, Shaft Drive
9-10.....	Parts List,(Diaphragm pump,Electric valves,Shaft drive
11.....	Plumbing Breakdown,(Centrifugal pump,Manual valves,PTO drive
12.....	Parts List,(Centrifugal pump,Manual valves.PTO drive
13.....	Plumbing Breakdown,(Centrifugal pump,Electric valves,Shaft drive
14.....	Parts List,(Centrifugal pump,Electric valves,Shaft drive
15.....	Plumbing Breakdown,(Roller pump,Manual valve,PTO drive
16-17.....	Parts List,(Roller pump,Manual valve,PTO drive
18-19.....	RO-110 Breakdown and Parts List
20.....	Centrifugal Pump Breakdown and Parts List
21.....	1700C Breakdown and Parts List
22.....	AA17L Control Valve Breakdown and Part List
23.....	AA6B Control Valve Breakdown and Parts List
24-25.....	2502 Electric Control Valve Breakdown and Parts List
26.....	AA43 Spray Gun Breakdown and Parts List
27-29.....	Mounting and Assembly Instructions
30.....	Calibration

30-31.....Maintenance and Precautions

32.....Trouble Shooting

33.....Tip Chart,(TP8003 Standard)

34.....Technical Information

200 & 300 GALLON 3 POINT HITCH LEVELING BOOM 12 ROW

Van's has made our Hydraulic Leveling Boom System available on our 200 and 300 Gallon 3 Point Hitch Sprayer Line. This Boom Leveling option is desirable in areas where uneven ground and terraced fields are encountered.

SHOWN L30025QJ ROLLER PUMP , QUICK JET BOOM PLUMBING MANUAL VALVE

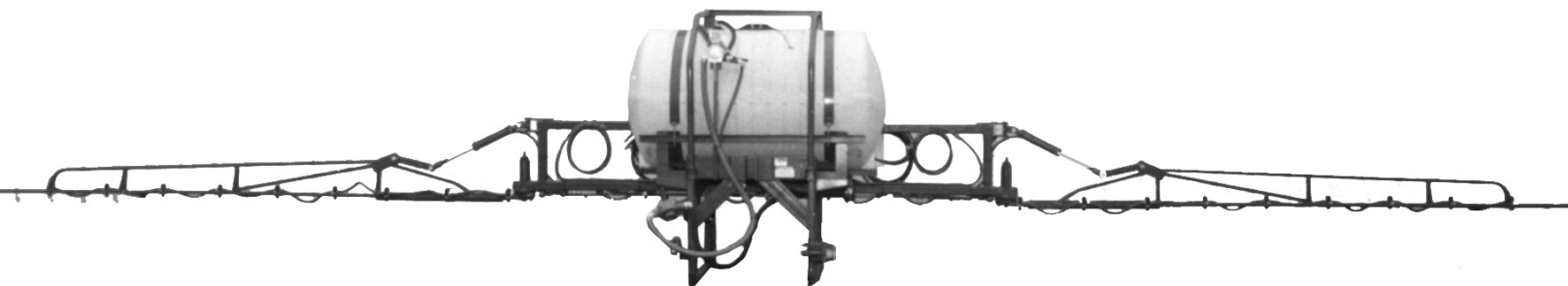

12 ROW MODEL	1700 ROLLER PUMP	RO-106 DIAPHRAGM PUMP	9006 CENTRIFUGAL PUMP
200 GALLON 12 ROW QUICK JET	LE20025QJ	LE20045QJ	LE20055QJ
300 GALLON 12 ROW QUICK JET	LE30025QJ	LE30045QJ	LE30055QJ

Standard Features include:

- 1) 200 or 300 Gallon Polyethylene Tank
- 2) Choice of Nylon, Brass or Quick Jet Boom Plumbing
- 3) Variable Spacing Nozzle Outlets
- 4) Full Set 8003 Tips, Cap & Strainers
- 5) Choice of Pumps
- 6) Full Five Year Structural Warranty
- 7) Fully Assembled & Factory Tested
- 8) Booms Fold & Level Hydraulically

Options:

1) Hand Gun w/Hose Rack

Add:

Part No.

H11F

CAUTION: Chemicals can be dangerous. Always follow instructions on the chemical container label. Improper selection or use of chemicals can cause serious injury to humans and the environment. Be Safe. Select the right chemical and handle it with care.

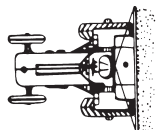

van's

EQUIPMENT COMPANY

P.O. BOX 3157 • 2169 SYLVESTER HIGHWAY • MOULTRIE, GEORGIA 31776-3157

(229) 985-1101

(PRICES SUBJECT TO CHANGE WITHOUT NOTICE)

We Appreciate You and Your Business!

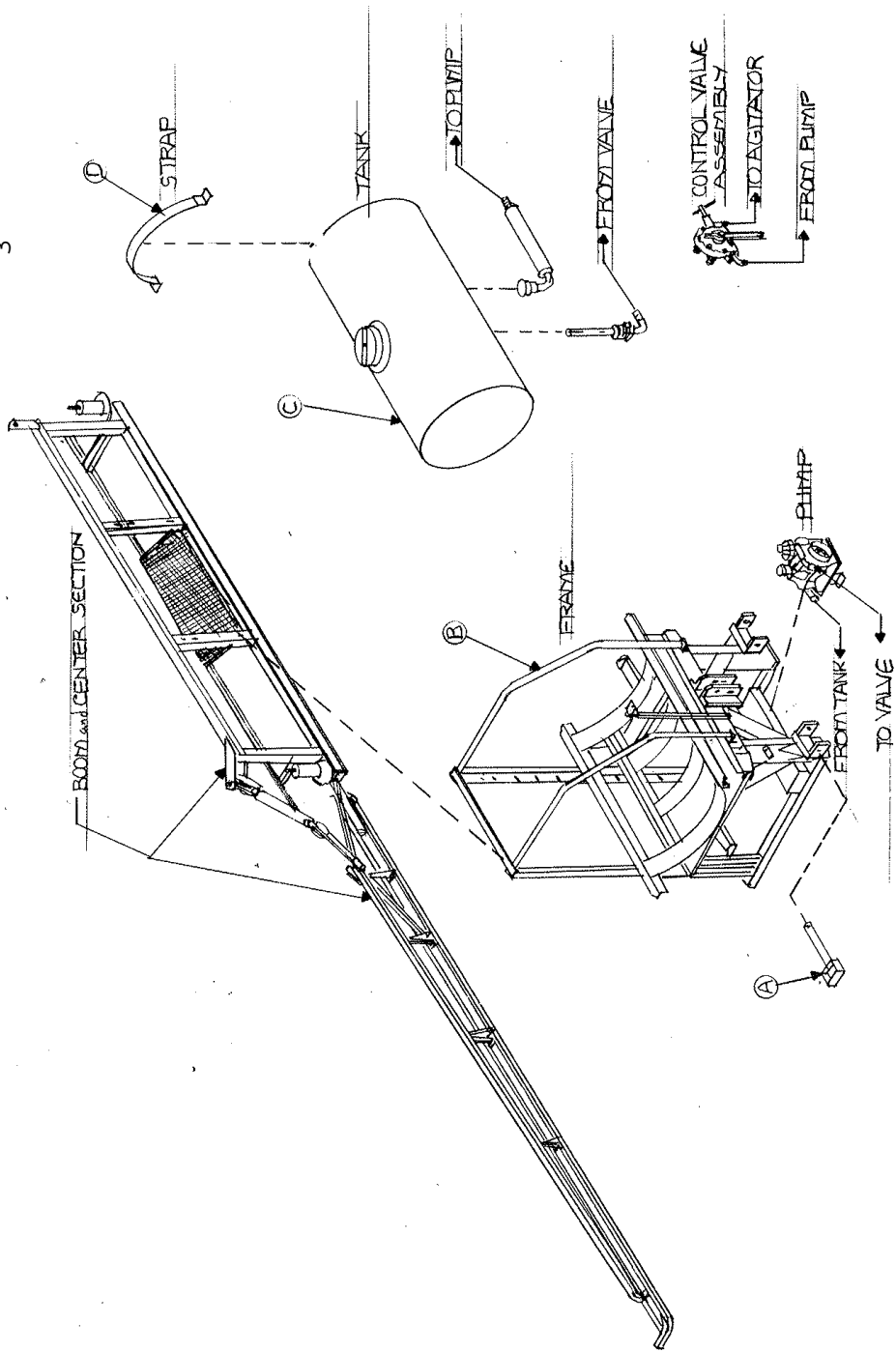

ITEM	DESCRIPTION	PART NO.
A	L200 category pin	IC-49
A	L300 category pin	IC-69
B	L200 frame	L200A
B	L300 Frame	L300A
C	L200 tank	47068
C	L300 tank	47375
D	L200 strap	SP60
D	L300 strap	SP72

**LEVELING BOOM
200 and 300 Lift Type
BREAKDOWN**

REF. NO.	DESCRIPTION	PART NO.	QUANTITY	PRICE EA.
1	Outer Boom Left Side	B12L	1	413.00
1A	Outer Boom Right Side	B12R	1	413.00
2	1/2" x 4" Bolt	CS12312C	2	1.16
3	1/2" Lock Nut	HLN12C	2	.45
4	Cylinder Pin Latch	640111	4	.39
5	Cylinder Pin	640091	2	8.52
6	Boom Leveling Bracket	IY-396	2	13.39
7	2 x 8 Hydraulic Cylinder	638010	4	133.00
8	Center Section	CS12L	1	1,364.00
9	3/4" Nut	HN34C	2	.53
10	Spring Collar	TV103-D	2	5.65
11	Compression Spring	25-7HD	2	38.00
12	Cradle, Left	TD91LS	1	95.00
12A	Cradle, Right	TD91RS	1	95.00
13	Boom Yoke	VV102S-HD	2	130.00
14	3/4" x 14" Bolt	CS341400C	2	21.78
15	4 Ft. Hydraulic Hose	HY4-90 -3/8	2	27.87
16	1/4" Galvanized Tee	GT1400	2	1.74
17	14 Ft. Hydraulic Hose	HY14 -3/8	2	52.41
18	1/4" x 1" Galvanized Nipple	GN141	2	1.23
19	1/4" x 3/8" Restricted Orifice	50349	6	9.84
20	Breather Plug	F38H	2	5.94
21	15 Ft. Hydraulic Hose	HY15-90 -3/8	2	65.17
22	Cylinder Hinge	IY-219	2	34.00
23	3/4" Lock Nut	HLN34C	2	1.54
24	3/4" Bolt	CS34500C	2	2.77

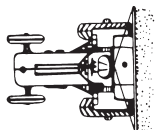
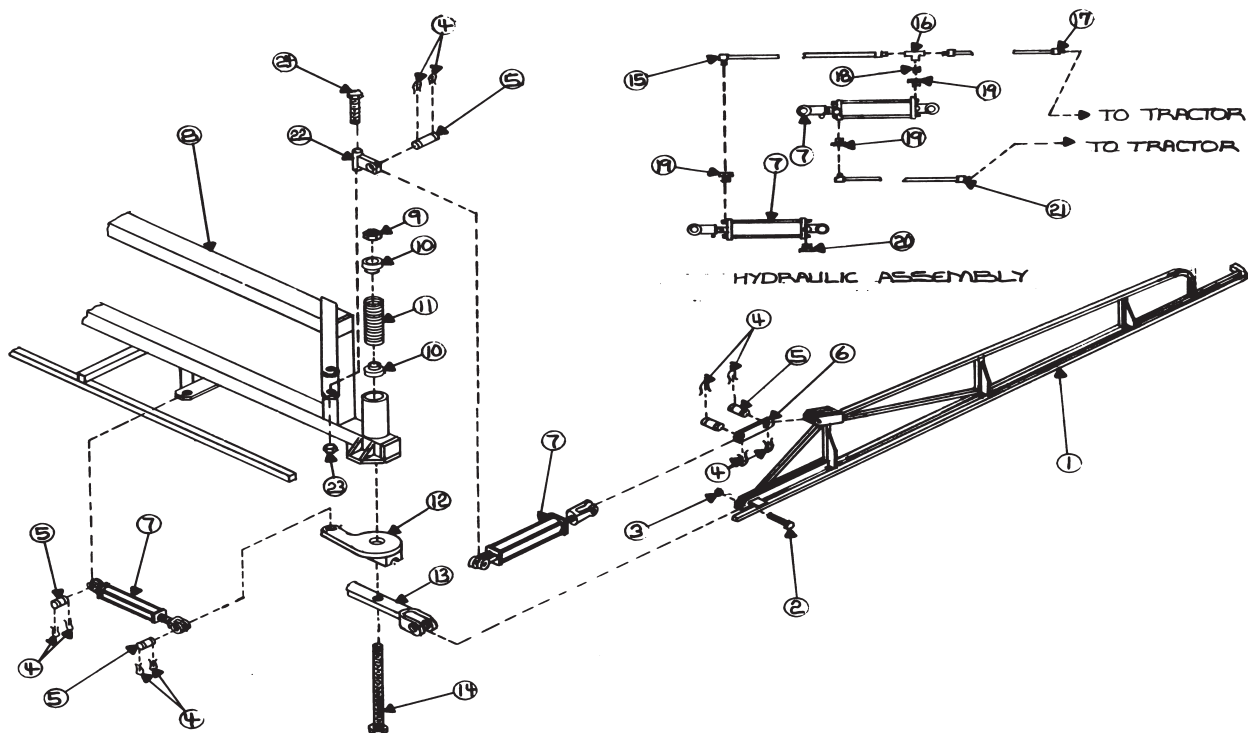

van's

EQUIPMENT COMPANY

P.O. BOX 3157 • 2169 SYLVESTER HIGHWAY • MOULTRIE, GEORGIA 31776-3157

We Appreciate You and Your Business!

(229) 985-1101

(PRICES SUBJECT TO CHANGE WITHOUT NOTICE)

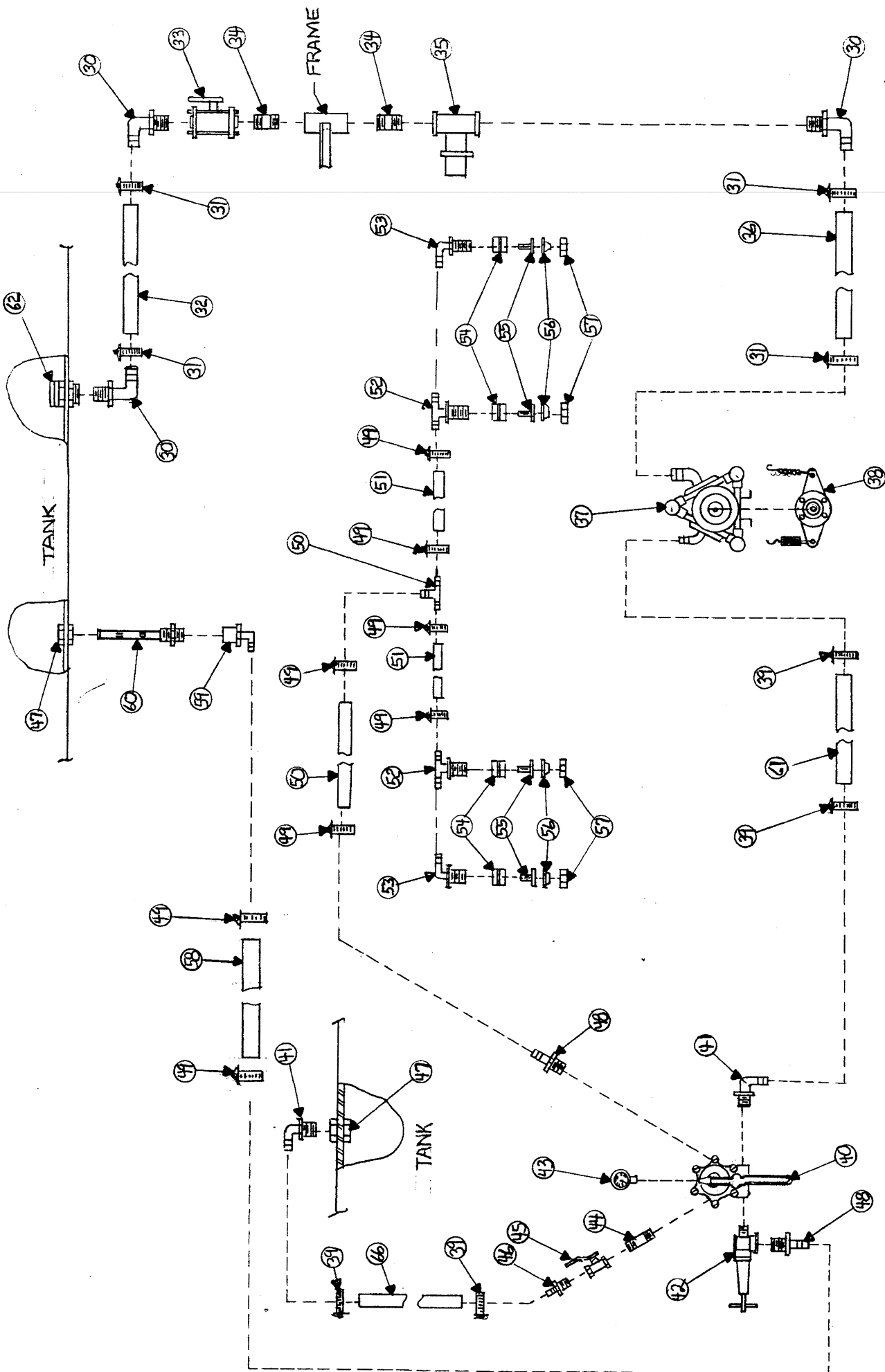

ITEM NO.	DESCRIPTION	PART NO.
30	Elbow 1 1/4" MPT x 1 1/2" Barb 90 Nylon	EL114112
31	Hose Clamp 1 1/2"	28H
32	Hose Wire Coil 1 1/2"	12003501
33	Ball Valve 1 1/2" FPT Poly	V-150
34	Nipple 1 1/2" x Close Galvanized	GN1121.5
35	Strainer 1 1/2" FPT 20 Mesh Nylon	3350-0112
36	Hose Wire Coil 1 1/2"	12003501
37	Pump Daipharm	RO-160
38	PTO Adaptor	7752.A2
39	Hose Clamp 3/4"	12H
40	Control Valve	AA17L
41	Elbow 3/4" MPT x Barb 90 Nylon	EL34
42	Pressure Relief Valve	3/4 8460
43	Pressure Gauge 0-300 PSI Liquid Filled 1/4" MPT	GG-300
44	Nipple 3/4" x 3" Galvanized	GN343
45	Ball Valve 3/4" FPT Brass	34BBV
46	Hose Shank 3/4" MPT x Barb Nylon	A34
47	Tank Fitting 3/4" Double Thread Nylon	A34
48	Hose Shank 3/4" MPT x 1/2" Barb Nylon	A3412
49	Hose Clamp 1/2"	12H
50	Insert Tee 1/2" Barb Nylon	T12
51	Hose 1/2" Black Ag. 300 PSI	10031730
52	Nozzle Body Tee 1/2" Nylon	3NTT12
52A	Nozzle Body Tee 1/2" Brass	900.053
52B	Nozzle Body Tee 1/2" Quick Jet	22252-312-500-NYB
53	Nozzle Body Elbow 1/2" Nylon	3NTL12
53A	Nozzle Body Elbow 1/2" Brass	900.052
53B	Nozzle Body Elbow 1/2" Quick Jet	22251-311-500-NYB
54	Boom Clamp 1" (Nylon and Brass)	AA111SQ-1
54A	Boom Clamp 1" (Quick Jet)	QJ111SQ-1
55	Tip Strainer (Nylon and Quick Jet)	8079-PP-50
55A	Tip Strainer (Brass)	5053-50-SS
56	Tip (Standard)	TP8003
57	Tip Cap (Nylon)	CP8027-NYB
57A	Tip Cap (Brass)	CP1325
57B	Tip Cap (Quick Jet)	25612-6-NYR
59	Elbow 3/4" FPT x 1/2" Barb 90 Nylon	EL3412F
60	Jet Agitator	3371-0019
61	Hose Black Ag. 1"	10031660
62	Tank Fitting 1 1/4" Anti-Vortex Nylon	63065

RO-106 Electric Valves Drive Shaft

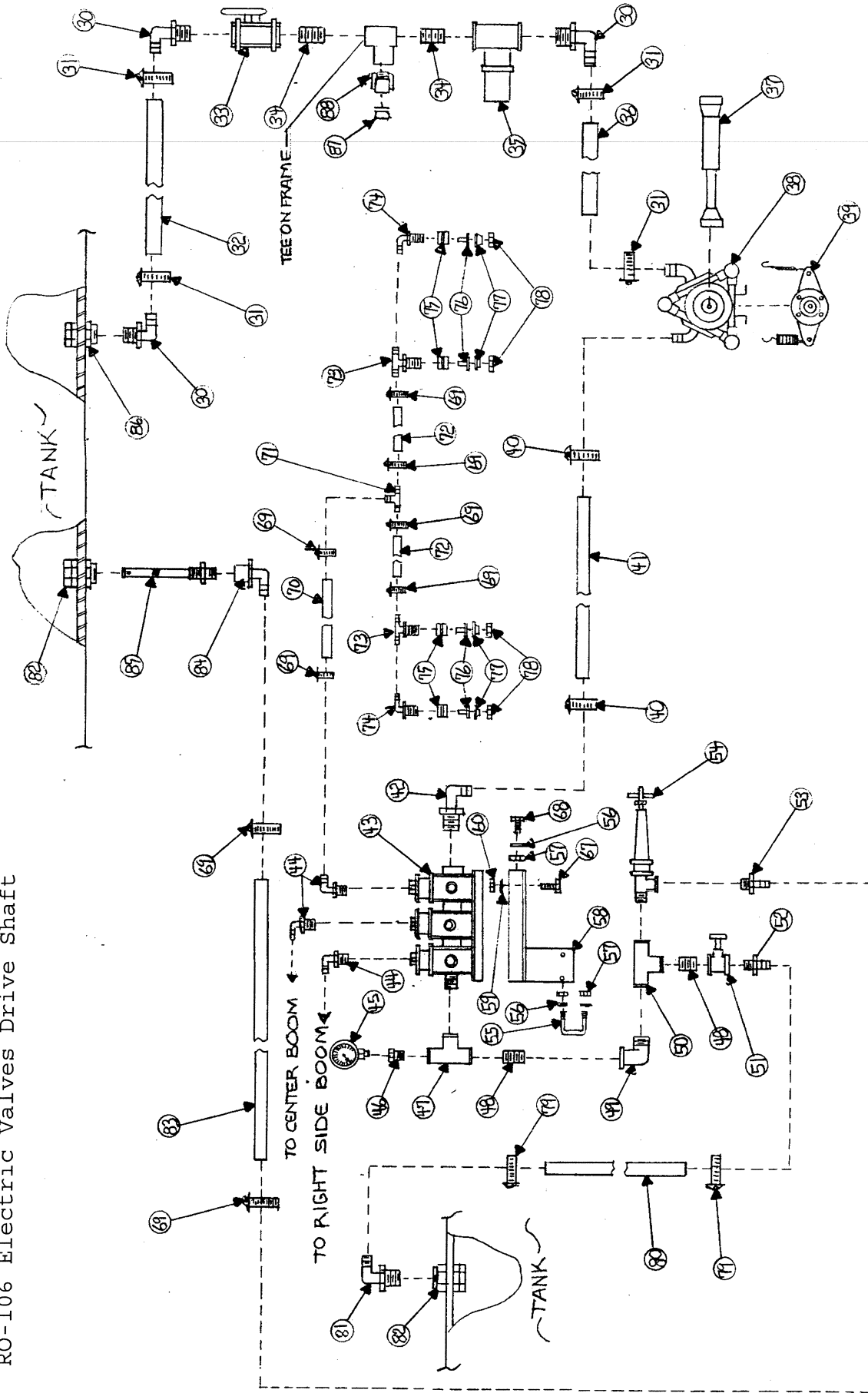

ITEM NO.	DESCRIPTION,(RO-110,ELECRIC VALVES,SHAFT DRIVE)	PART NO.
30	Tank Fitting 1 1/4" Anti-Vortex	63065
31	Hose Clamp 1 5/8"	28H
32	Hose Wire Reinforced 1 1/2"	12003501
33	Ball Valve 1 1/2" FPT Poly	V-150
34	Nipple 1 1/2"x Close Galvanized	GN1121.75
35	Strainer Nylon 1 1/2" FPT 20 Mesh	3350-0112
36	Hose Wire Reinforced 1 1/2"	12003501
37	PTO Shaft Standard	7101061NN007007
38	Pump Diaphragm	RO-110/C
39	PTO Adaptor (Not Applicable)	N/A
40	Hose Clamp 1"	20H
41	Hose 1" Black Ag.	10031660
42	Elbow Nylon 1" MPTx Barb	EL112
43	Electric Control Valve	2502-3
44	Elbow Nylon 1/2" MPTx Barb	EL12
45	Gauge 0-300 PSI Liquid Filled	GG-300
46	Reducer Bushing 3/4"x 1/4" Nylon	RB3414
47	Tee 3/4" FPT Nylon	TT34
48	Nipple 3/4"x Close Nylon	M34
49	Street Elbow 90 Nylon	SE34
50	Tee 3/4" FPT Nylon	TT34
51	Gate Valve 3/4" Brass	34BGV
52	Hose Shank 3/4"MPT x 1/2" Barb	A3412
53	Hose Shank 3/4"MPT x 1/2" Barb	A3412
54	Pressure Relief Valve	3/4/8460
55	U-Bolt,5/13"x 2"x 1 3/8" Square	SQU516200
56	Flat Washer 5/16"	FW516
57	Nut 5/16"	HN516C
58	Valve Stand for 2502-3	VS2500-3
59	Lock Washer 3/8"	LW38
60	Nut 3/8"	HN38C
67	Bolt 3/8"x 1 1/4"	CS38114C
68	Bolt 1/4"x 3/4"	CS1434C
69	Hose Clamp 1/2"	8H
72	Hose 1/2" Black Ag	10031730
73	Nozzle Body,(1/2" Nylon Tee)	3NTT12
73A	Nozzle Body,(1/2" Brass Tee)	900.053
73B	Nozzle Body,(1/2" Quick Jet)	22252-312-500-NYB
74	Nozzle Body,(1/2" Nylon Elbow)	3NTL12
74A	Nozzle Body,(1/2" Brass Elbow)	900.052
74B	Nozzle Body,(1/2" Quick Jet)	22251-311-500-NYB
75	Boom Clamp,(Nylon and Brass)	AA111SQ-1
75A	Boom Clamp,(Quick Jet)	QJ111SQ-1
76	Tip Strainer,(Nylon and Quick Jet)	8079-PP-50
76A	Tip Strainer,(Brass)	5053-50-SS
77	Tip,(Standard)	TP8003

78	Tip Cap,(Nylon)	CP8027-NYB
78A	Tip Cap,(Brass)	CP1325
78B	Tip Cap,(Quick Jet	25612-4-NYR
79	Hose Clamp 1/2"	8H
80	Hose 1/2" Black Ag	10031730
81	Elbow Nylon 3/4"MPT x 1/2" 90 Barb	EL3412
82	Tank Fitting 3/4" Double Thread	60401
83	Hose 1/2" Red Ag.	3204-0410
84	Elbow 3/4"FPTx 1/2" 90 Barb	EL3412F
85	Jet Agitator	3371-0019

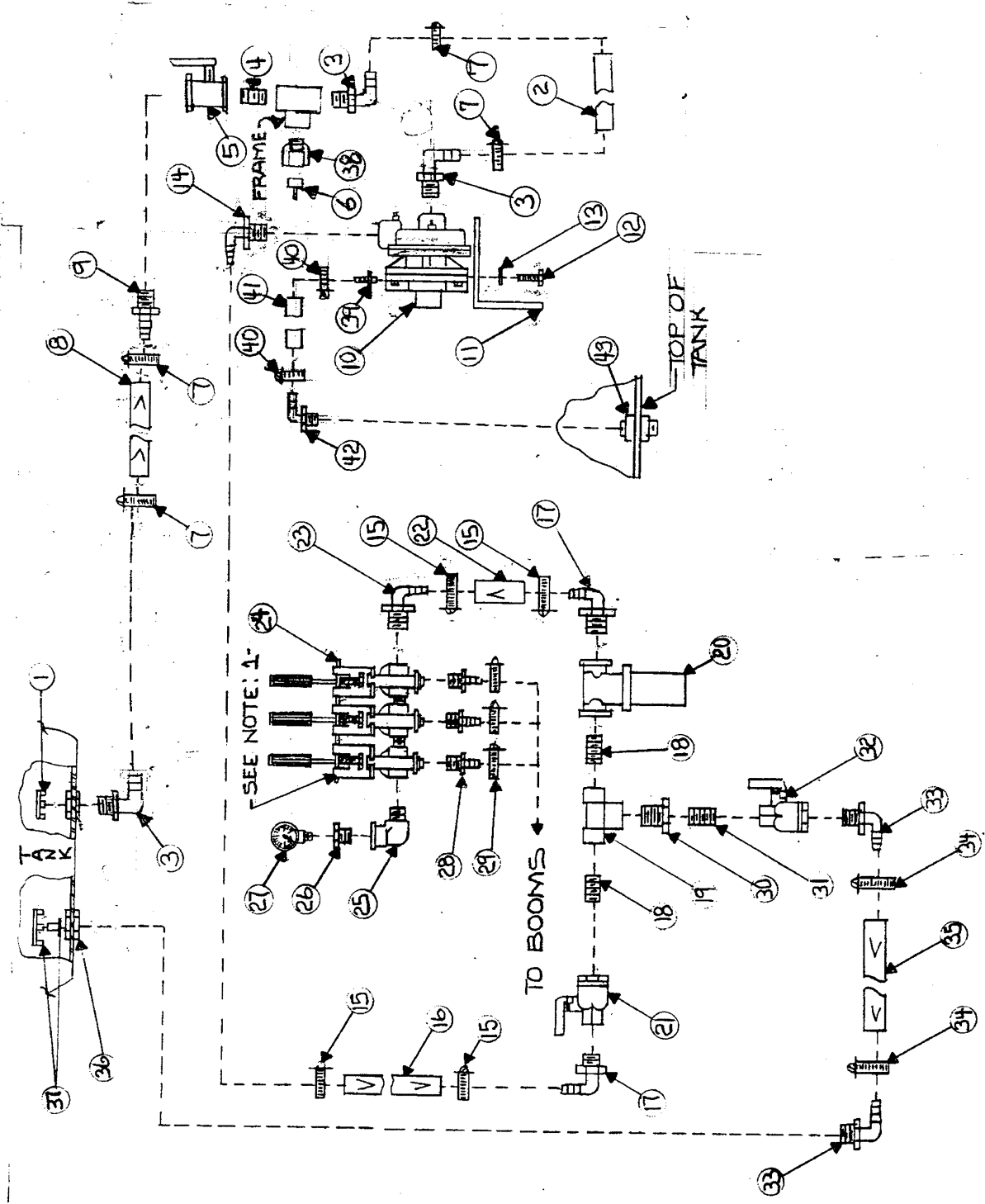

ITEM NO.	DESCRIPTION(9006C PUMP,MANUAL VALVE,PTO DRIVE	PART NO.
1	Tank Fitting 1 1/4" Anti-Vortex	63065
2	Hose Wire Reinforced 1 1/2"	12003501
3	Elbow 1 1/4"MPT x 1 1/2" Barb Nylon	EL114112
4	Nipple 1 1/2"x Close Galvanized	GN1121.75
5	Ball Valve 1 1/2" Poly FPT	V-150
6	Camlock Dust Plug 1 1/2"	150-PL
7	Hose Clamp 1 5/8"	28H
8	Hose Wire Reinforced 1 1/2"	12003501
9	Hose Shank MPT X Barb 1 1/2" Nylon	A112
10	Pump Centrifugal 160 GPM , 80PSI , 540 RPM	9006C
11	PTO Mounting Clip	1520-0034
12	3/8" Bolt x 1 1/4"	CS38114C
13	3/8" Lock Washer	LW38
14	Elbow 1 1/4"MPT x 1 " Barb Nylon	EL114100
15	Hose Clamp 1 "	20H
16	Hose 1" Black Ag.	10031660
17	Elbow 1" MPT x Barb Nylon	EL100
18	Nipple 1"x Close Galvanized	GN1001.5
19	Tee 1" FPT Nylon	TT100N
20	N/A	
21	Brass Gate Valve 1" FPT	100BGV
22	Hose 1" Black Ag.	10031660
23	Elbow 3/4"MPTx 1" Barb	EL3410
24	Control Valve	AA6B
25	Street Elbow Nylon 3/4" 90	SE34
26	Reducer Bushing 3/4" x 1/4" Nylon	RB3414
27	Pressure Gauge 0-100 PSI Liquid Filled	GG-100
28	Hose Shank MPT X Barb 1/2" Nylon	A12
29	Hose Clamps 1/2"	8H
30	Reducer Bushing 1"x 3/4" Nylon	RB10034
31	Nipple 3/4" x Close Galvanized	GN341.5
32	Brass Gate Valve 3/4" FPT	34BGV
33	Elbow 3/4"MPTx 3/4" Barb	EL34
34	Hose Clamps3/4"	12H
35	Hose 3/4" Red Ag.	3204-0420
36	Tank Fitting 3/4" Double Thread	60401
37	N/A	
38	Cam Lock Coupler x MPT	150-B
39	Hose shank 1/8"MPT x 1/4" Barb Brass	A1814B
40	Hose Clamp 1/8"	M4P
41	1/4" clear Tubing	N/A
42	Elbow 1/2"MPT x 1/4" Barb 90 Nylon	EL1214
43	Tank Fitting 1/2"	67158

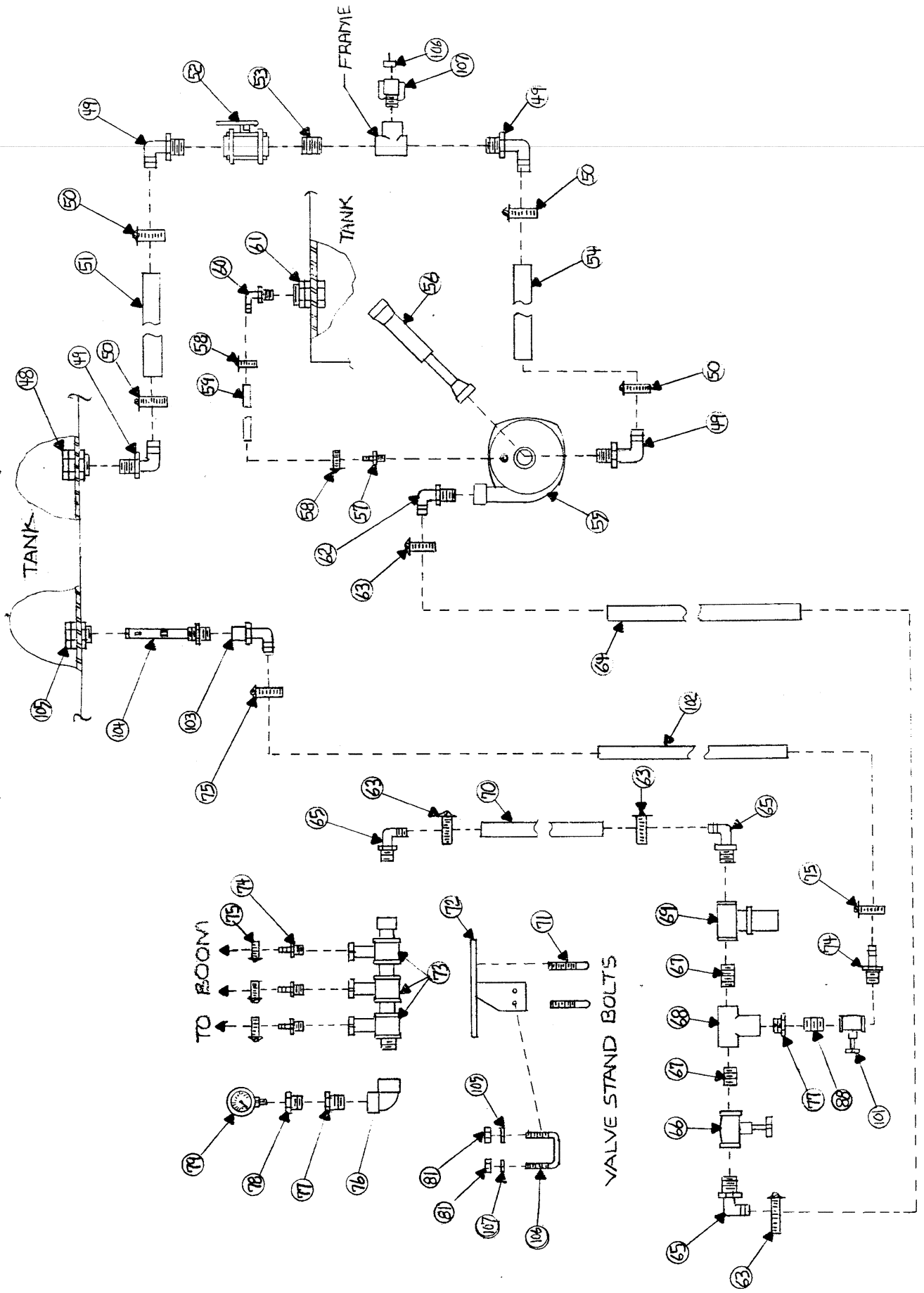

ITEM NO.	DESCRIPTION	PART NO.
48	Tank fitting 1 1/4" anti-vortex	63065
49	Elbow 1 1/4"mpt x 1 1/2" barb 90 nylon	EL114112
50	Hose clamp 1 5/8"	28H
51	Hose wire reinforced 1 1/2"	12003501
52	Ball valve 1 1/2" fpt poly	V-150
53	Nipple 1 1/2" x close galvanized	GN1121.75
54	Hose wire reinforced 1 1/2"	12003501
55	Pump centrifugal 160 gpm, 80 psi , 540rpm	9006C
56	Drive shaft 1" round x 1 3/8" 6 spline	710161NN007602
57	Hose shank 1/8"mpt x 1/4" barb brass	A1814B
58	Hose clamp 1/4"	M4P
59	1/4" clear tube	CALL
60	Elbow 1/2"mpt x 1/4" barb 90 nylon	EL1214
61	Tank fitting 1/2"	67158
62	Elbow 1 1/4"mpt x 1" barb 90 nylon	EL114100
63	Hose clamp 1"	20H
64	Hose black ag 1"	10031660
65	Elbow 1"mpt x 1"barb 90 nylon	EL100
66	Gate valve 1"fpt brass	100BGV
67	Nipple 1" x close galvanized	GN1001.5
68	Tee 1" fpt nylon	TT100N
69	Strainer 1"fpt 50 mesh nylon	AA126-ML-4-50
70	Hose black ag 1"	10031660
71	U bolt 5/16" x2" x 3" round	RU516300
72	Valve stand	VS2500-3
73	Electric valve 3 bank	2502-3
74	Hose shank 1/2"mpt x 1/2" barb nylon	A12
75	Hose clamp 1/2"	12H
76	Elbow 3/4"mpt x barb 90 nylon	EL34
77	Reducer bushing 1" mpt x 3/4"fpt nylon	RB10034
78	Reducer bushing 3/4" mpt x 1/4"fpt nylon	RB3414
79	Pressure gauge 0-100 psi liquid filled	GG-100
80	Nipple3/4" x close galvanized	GN341.5
81	Nut 5-16"	HN516C
103	Elbow 3/4"mpt x barb 90 nylon	EL34
104	jet agitator	3371-0019
105	Tank fitting 3/4" double thread	60401
106	U bolt 5/16" x2" x 1 3/8" square	SQU516200
107	Lock washer 5/16	LW516

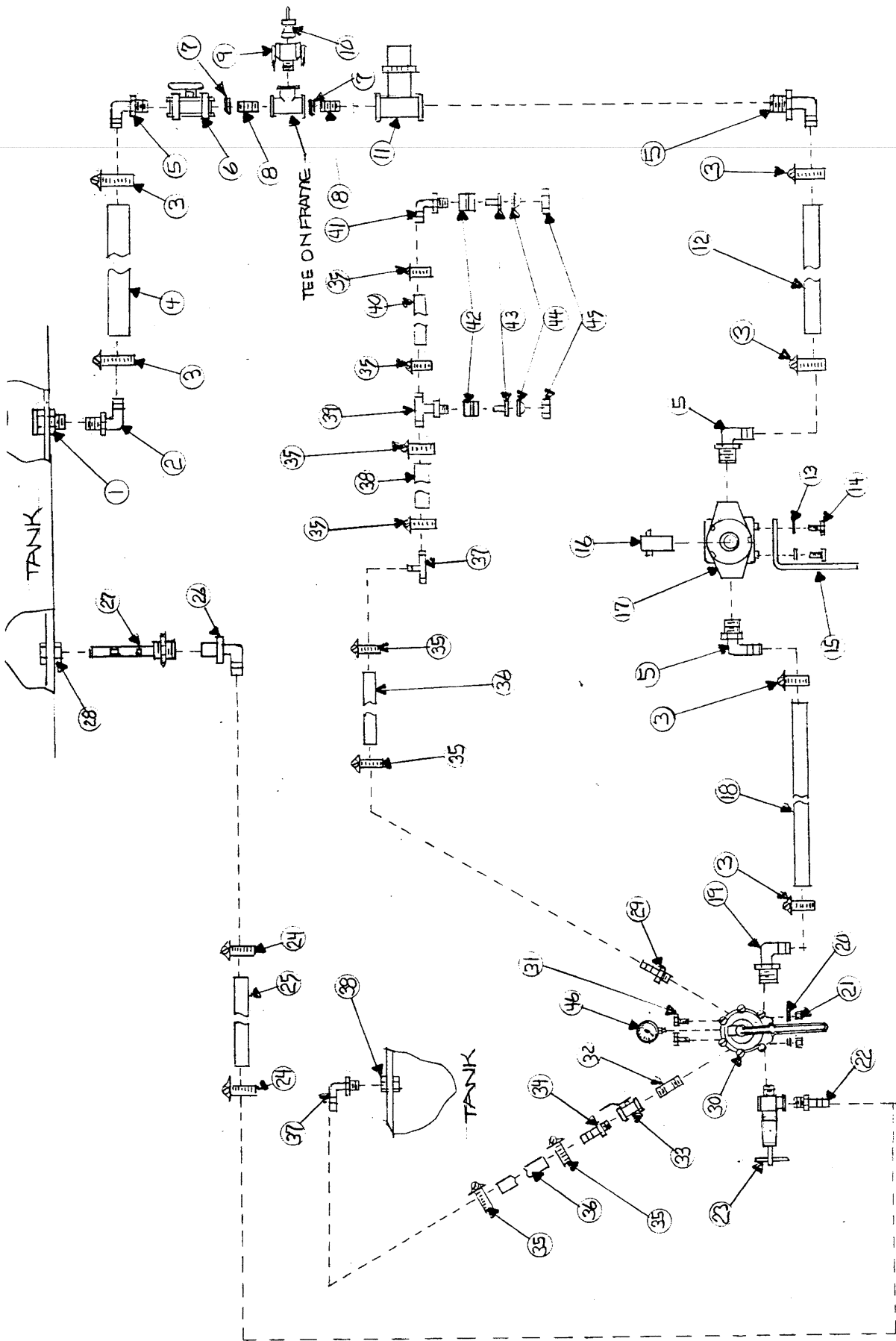

ITEM NO.	DESCRIPTION	PART NO.
1	Tank fitting 1 1/4" anti-vortex	63065
2	Elbow 1 1/4"mpt x 1"barb 90 nylon	EL114100
3	Hose clamp 1"	20H
4	Hose wire coil 1"	12003485
5	Elbow 1"mpt x 1"barb 90 nylon	EL100
6	Ball valve 1" fpt poly	UV-100FP
7	Reducer bushing 1 1/2"mpt x 1"fpt galvanized	GB1121
8	Nipple 1" x close galvanized	GN1001.5
9	Cam lock coupler 1 1/2" mpt	150-B
10	Cam lock plug 1 1/2"	150-PL
11	Strainer 1" fpt 50 mesh nylon	AA124-ML-4-50
12	Hose wire coil 1"	12003485
13	Flat washer 5/16"	FW516
14	Bolt 5/16" x 3/4"	CS51634C
15	Pump stabilizer (standard)	PS
16	Pump coupler steel	114-1500
17	Roller pump	1700C
18	Hose black ag 1"	10031660
19	Elbow 3/4"mpt x 1"barb 90 nylon	EL3410
20	Lock washer 3/8"	LW38
21	Nut 3/8"	HN38C
22	Hose shank 3/4"mpt x 1/2"barb nylon	A3412
23	Pressure relief valve	3/4/8460
24	Hose clamp 1/2"	8H
25	Hose red ag 1"	3204-0410
26	Elbow 3/4"fpt x 1"barb 90 nylon	EL3412F
27	Jet agitator	3371-0019
28	Tank fitting 3/4"	60401
29	Hose shank 3/4"mpt x 1/2"barb nylon	A3412
30	Control valve	AA17L
31	Bolt 3/8" x 1 1/4"	CS38114C
32	Nipple 3/4" x 3" galvanized	GN343
33	Ballvalve 3/4" brass	34BBV
34	Hose shank 3/4"mpt x 3/4"barb nylon	A34
35	Hose clamp 3/4"	12H
36	Hose red ag 3/4"	3204-0420
37	Insert tee 1/2"	T12
38	Hose black ag 1/2"	10031730
39	Nozzle body 1/2" tee nylon	3NTT12
39A	Nozzle body 1/2" tee brass	900.053
39B	Nozzle body 1/2" tee quick jet	22252-312-500-NYB
40	Hose black ag 1/2"	10031730
41	Nozzle body 1/2" elbow nylon	3NTL12
41A	Nozzle body 1/2" elbow brass	900.052
41B	Nozzle body 1/2" elbow quick jet	22251-311-500-NYB
42	Boom clamp for nylon or brass	AA111SQ-1

42A	Boom clamp for quick jet	QJ111SQ-1
43	Tip strainer nylon & quick jet	8079-PP-50
43A	Tip strainer brass	5053-50-SS
44	Tip standard	TP8003
45	Tip cap nylon	CP8027-NYB
45A	Tip cap brass	CP1325
45B	Tip cap quick jet	25612-4-NYR

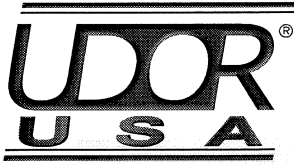

RO-110

Exploded View Diagram and Parts List

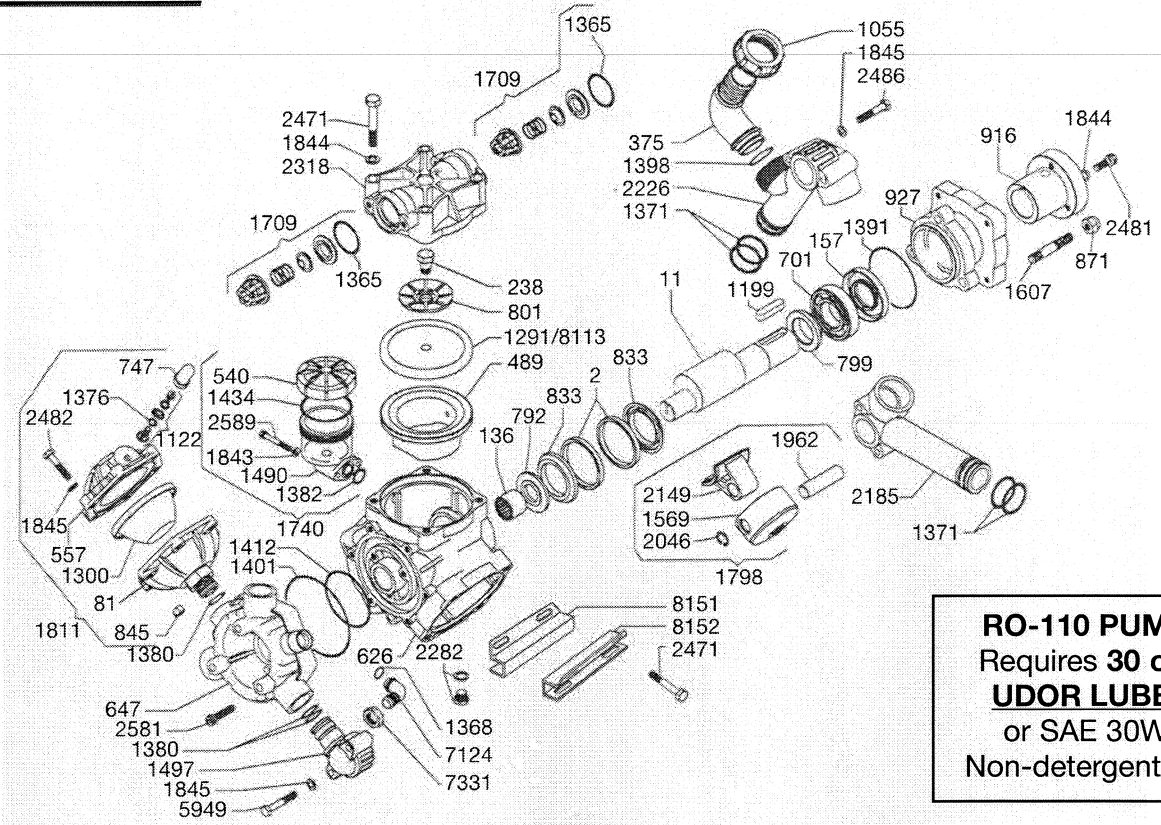

RO-110 PUMP
 Requires 30 oz.
UDOR LUBE,
 or SAE 30W
 Non-detergent Oil

RO-110

REF#	PART#	DESCRIPTION	QTY	REF#	PART#	DESCRIPTION	QTY
2	0001.02	Retainer Ring	2	1398	1101.42	O-Ring	1
11	0002.60	Crank Shaft	1	1401	1101.58	O-Ring	1
81	0003.15	Accumulator	1	1412	1101.79	O-Ring	1
136	0006.07	Bearing	1	1434	1101.D1	O-Ring	1
157	0007.05	Seal	1	1490	1203.27	Oil Reservoir	1
238	0102.03	Diaphragm Bolt	3	1497	1203.36	Manifold Elbow	3
375	0202.78	Suction Elbow	1	1569	1205.06	Piston	3
489	0206.14	Piston Sleeve	3	1607	1206.22	Stud	3
540	0208.98	Oil Cap	1	1709	6006.08	Valve Assembly	6
557	0208.20	Accumulator Head	1	1740	6033.01	Oil Reservoir Assembly	1
626	0209.34	Crank Case	1	1798	6015.24	Piston Rod Assembly	3
647	0257.07	Discharge Manifold	1	1811	6031.09	Accumulator Assembly	1
701	0214.05	Bearing	1	1843	1403.07	Washer	2
747	0218.01	Air Valve Cap	1	1844	1403.09	Washer	9
792	0301.12	Washer	1	1845	1403.10	Washer	18
799	0301.24	Washer	1	1962	1502.01	Connecting Rod Pin	3
801	0301.07	Retainer Washer	3	2046	1506.02	Snap Ring	6
833	0302.52	Rod Spacer	2	2149	1519.16	Connecting Rod	3
845	0303.01	Nut	6	2185	1601.13	Suction Manifold	2
871	0304.04	Lock Nut	3	2226	1602.22	Suction Manifold	1
916	0501.62	Crank Shaft Flange	1	2282	1603.50	Drain Plug	1
927	0501.79	FLANGE	1	2318	1604.36	Head	3
1055	0604.50	Barb Nut	1	2471	1804.29	Bolt	12
1122	0608.16	Air Valve Assembly	1	2481	1804.07	Bolt	1
1199	0801.11	Key	1	2482	1804.09	Bolt	6
1291	0903.02	Diaphragm (BUNA-N, Optional)	3	2486	1804.79	Bolt	6
*1300	0903.14	Accumulator Diaphragm	1	2581	1805.03	Bolt	9
*1365	1101.01	O-Ring	6	2589	1805.31	Bolt	2
1368	1101.04	O-Ring	1	5949	1804.72	Bolt	6
1371	1101.07	O-Ring	6	7124	0253.05	Discharge Elbow	1
1376	1101.16	O-Ring	1	7331	0604.36	Discharge Nut	1
1380	1101.25	O-Ring	7	*8113	0903.34	Diaphragm (DESMOPAN, Standard)	3
1382	1101.29	O-Ring	1	8151	1202.63	Mounting Rail - Right Side	1
1391	1101.43	O-Ring	1	8152	1202.64	Mounting Rail - Left Side	1

* Parts Included in Diaphragm Repair Kit - #8700.04. (Also available in Buna-N - #8700.11.)



RO-110

Low Pressure Diaphragm Pump

RO-110 low pressure, 3-cylinder diaphragm pumps are excellent for various horticultural and agricultural spraying applications. Simplicity of design and common parts allow easy and affordable maintenance. A built-in pulsation dampener and mounting rails are standard.

The RO-110 has an anodized aluminum body, plasticized aluminum heads, glass-filled nylon manifolds and stainless steel liquid handling parts.

Several drive options are available, including:

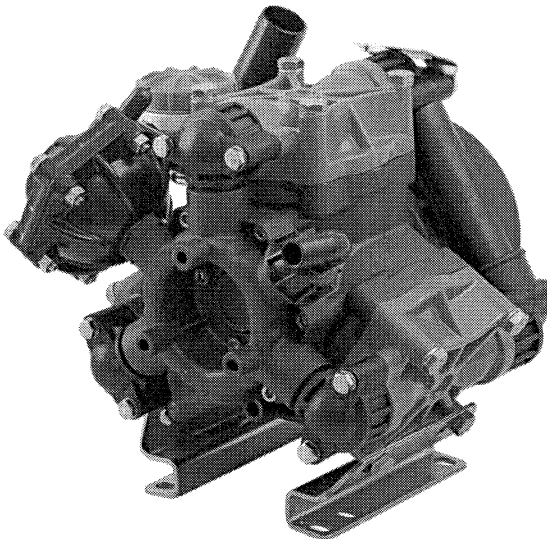

Part Number	Description
4155.00	Hydraulic Motor Mounting Kit
5033.A4	Gear Reduction for 8-13 HP
7751.A3	1" Solid Keyed Shaft and Bolts
7753.A6*	1-3/8" 6-Spline Male Shaft & Bolts

For industrial uses and spraying applications not listed, please consult UDOR U.S.A.

*For ALL PTO Drive Applications, Safety Shield (Part #1219.25) is Recommended.

SPECIFICATIONS

Maximum Flow	29 GPM
Maximum Pressure	300 PSI
Maximum RPM	540 RPM
Maximum Temperature	140°F
Inlet Port (Hose Barb)	1-1/2"
Outlet Port (Hose Barb)	3/4"
Dimensions	L-14" x W-11.5" x H-12"
Weight	45 lbs.
Diaphragm Material	
Standard	DESMOPAN
Optional	BUNA-N

NOTE - Protect pumps from freezing. If freezing conditions exist, flush pump and system with a 50/50 mixture of antifreeze and water.

RO-110

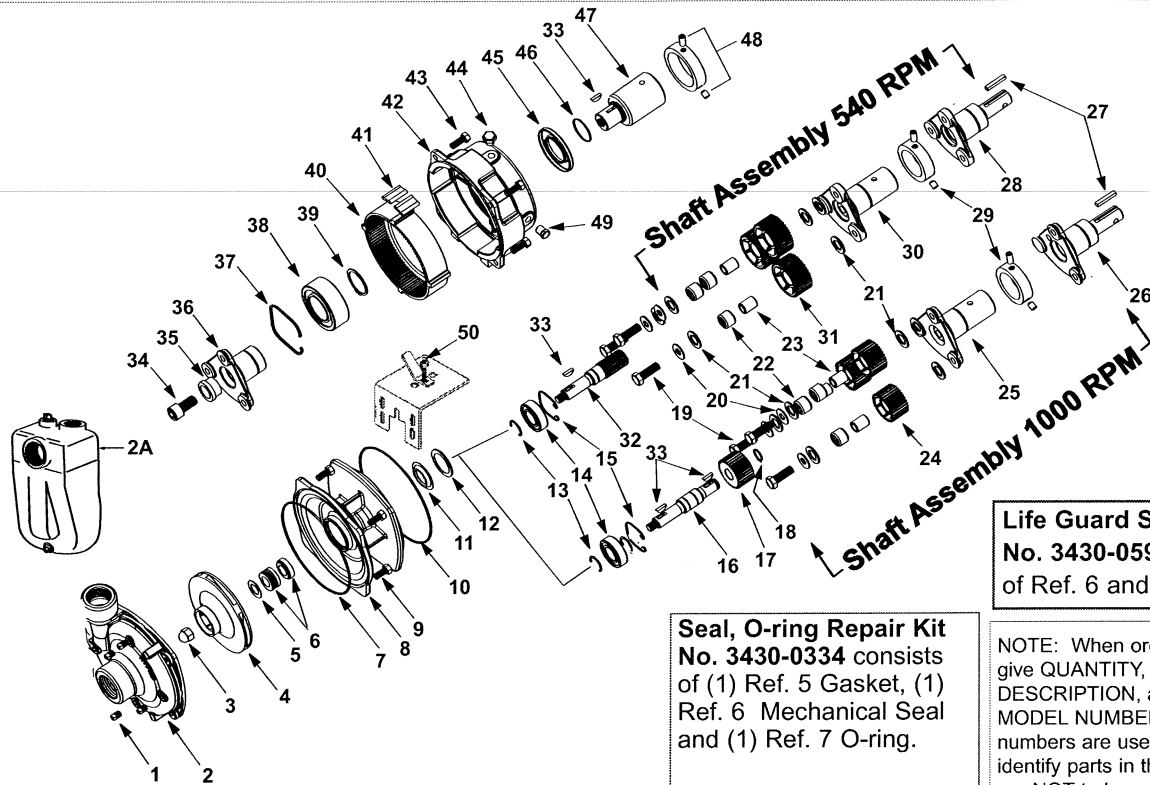

Ref. No.	Qty. Req'd.	Part No.	Description
1	4	2406-0007	Drain Plug
2	1	0150-9000C	Pump Casing (w / SS wear ring)
2A	1	3430-0480SP	Pump Casing (Self-Priming Units)
3	1	2253-0001	Impeller Nut
4	1	0400-9000P	Impeller (Nylon)
5	1	1700-0101	Gasket
6	1	2120-0010	Mechanical Seal (Optional Buna-N)
6	1	2120-0011	Mechanical Seal (Standard Viton)
7	1	1720-0083	O-ring
8	1	0752-9000C	Mounting Flange Adapter
9	4	2210-0020	Hex Head Capscrew
10	1	1720-0139	O-ring
11	1	2130-0018	Bearing Lip Seal
12	1	1700-0098	Gasket
13	*	1810-0013	Retaining Ring — (1) required for 540 rpm, (2) for 1-3/8" and (3) for 1-3/4" 1000 rpm
14	1	2008-0001	Ball Bearing
15	1	1820-0025	Retaining Ring
15	3	2210-0046	Capscrew
16	1	0500-9002	Impeller Shaft (1000 rpm)
17	1	3900-0013	Sun Gear (1000 rpm)
18	1	1810-0011	Retaining Ring (1000 rpm)
19	3	2210-0046	Hex Head Capscrew
20	3	2270-0003	Washer
21	6	2265-0003	Thrust Washer
22	3	2007-0052	Bearing (included with driver gear)
23	3	2007-0022	Bearing Inner Race
24	3	3900-0040	Driver Gear w/Bearing (1000 rpm) 32 teeth, Dia. 2.13"

Ref. No.	Qty. Req'd.	Part No.	Description
25	1	0562-9002D	Driver Hub (Model 9008C-O)
26	1	0501-9018D	Driver Hub (Model 9018C-O)
27	1	1610-0005	Key
28	1	0501-9016D	Driver Hub (Model 9016C-O)
29	1	3435-0058	Locking Collar Kit (hollow shaft)
30	1	0562-9000D	Driver Hub (Model 9006C-O)
31	3	3900-0039	Driver Gear w/Bearing (540 rpm) 39 teeth, Dia. 2.6"
32	1	3900-0010	Impeller Shaft/Pinion Gear (540 rpm)
33	**	1610-0012	Woodruff Key ** (1) req'd for 540 rpm, (2) req'd for 1000 rpm models.
34	1	2220-0035	Capscrew (Model 9028C)
35	1	2403-0012	Bushing (Model 9028C)
36	1	0501-9018D1	Driver Hub (Model 9028C)
37	1	1800-0014	Retaining Ring
38	1	2005-0002	Ball Bearing
39	1	1810-0001	Retaining Ring
40	1	3900-0009	Ring Gear
41	8	1450-0004	Cushion Bumper
42	1	0754-9000C	Gear Casing
43	4	2210-0026	Hex Head Capscrew
44	1	2404-0193	Breather Vent
45	1	2102-0025	Oil Seal
46	1	1720-0022	O-ring
47	1	0550-1322F4	Driver Hub (9028C) 1-3/4" Hub 20 Teeth
48	1	3430-0190	Locking Collar Kit (Model 9028C)
49	4	2406-0019	Oil Plug
50	1	1520-0034	Mounting Clip

Models 1700C, 1700N, and 1700XL

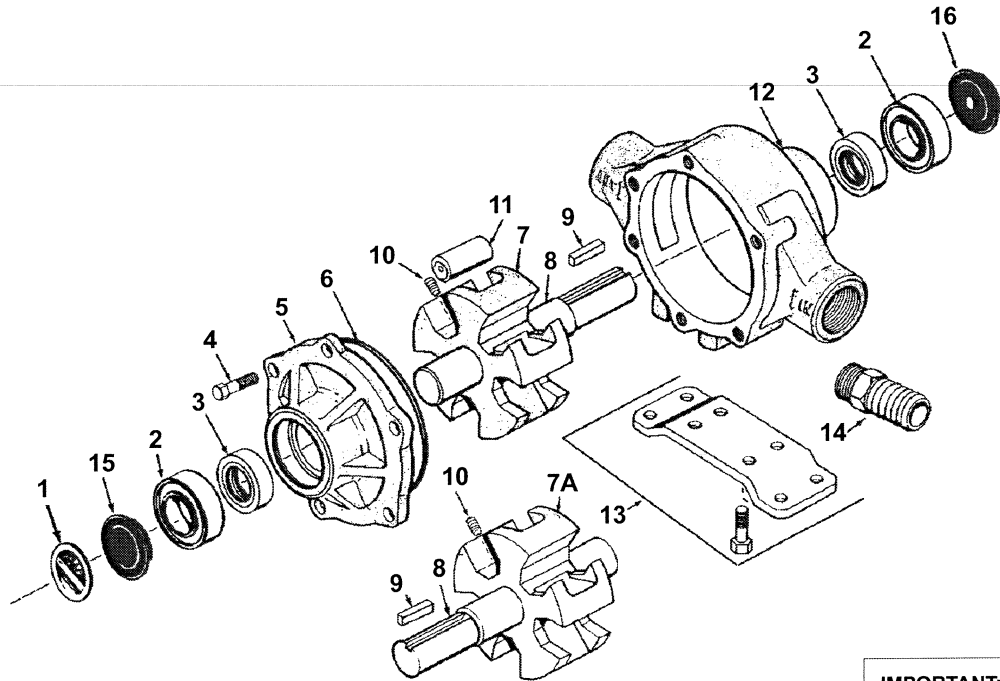

IMPORTANT:
When ordering parts, give PART NUMBER and PART DESCRIPTION. Reference Numbers are used ONLY to point out parts in the drawing and are NOT to be used as ordering numbers.

Ref. No.	Qty. Req'd.	Part Number	Description
1	1	6031-0258	Name Plate (Specify Pump Model #)
2	2	2008-0001	Sealed Ball Bearing
3	2	2112-0003	Viton Seal (Standard)
3	2	2112-0001	Buna-N Seal (Optional)
4	6	2210-0005	Bolt
5	1	0200-1700C	Endplate (Cast Iron) with Seal
5	1	0200-1700N	Endplate (Ni-Resist) with Seal
5	1	0200-1700X	Endplate (SilverCast) with Seal
6	1	1720-0099	O-ring Gasket for Endplate
7	1	0300-1700C	Rotor (Cast Iron) with shaft (Std. Rotation)
7	1	0300-1700N	Rotor (Ni-Resist) with shaft (Std. Rotation)
7	1	0300-1700X	Rotor (SilverCast) with shaft (Std. Rotation)
7A	1	0301-1700C	Rotor (Cast Iron) w/shaft (Reverse Rot.)
7A	1	0301-1700N	Rotor (Ni-Resist) w/shaft (Reverse Rot.)
7A	1	0301-1700X	Rotor (SilverCast) w/shaft (Reverse Rot.)

Ref. No.	Qty. Req'd.	Part Number	Description
8	1	0500-1502	Shaft Only
9	1	1610-0005	Key
10	1	2230-0018	Set Screw
10	1	2230-0034	Set Screw (SilverCast Only)
11	5	1005-0005	Super Roller (Standard)
11	5	1002-0005	Polypropylene Roller (Optional)
11	5	1055-0005	Teflon Roller (Optional)
12	1	0100-1700C	Body (Cast Iron) with Seal
12	1	0100-1700N	Body (Ni-Resist) with Seal
12	1	0100-1700X	Body (SilverCast) with Seal
13	1 kit	3420-0010	Base Kit — Sold Separately Includes: (1) Base and (4) Bolts
14	1	2404-0191	1-1/4" Hose Barb
15	1	2300-0020	Bearing Cover
16	1	2300-0022	Shaft Bearing Cover

See Page 17 for the proper coupler or adapter.

Repair Parts Kit No. 3430-0437 Consists of: (5) Ref. 12 Super Rollers, (1) Ref. 7 O-Ring Gasket, and (2) Ref. 4 Viton Seals.

Repair Parts Kit No. 3430-0383 (Universal) Consists of: (6) Ref. 12 Super Rollers, (2) Ref. 7 O-Ring Gaskets, and (2) Ref. 4 Viton Seals.

Repair Parts Kit No. 3430-0160 Consists of: (5) Ref. 12 Polypropylene Rollers and (1) Ref. 7 O-Ring Gasket, and (2) Ref. 4 Buna-N Seals.

Repair Parts Kit No. 3430-0159 Consists of: (5) Ref. 12 Polypropylene Rollers and (1) Ref. 7 O-Ring Gasket.

Repair Parts Kit No. 3430-0161 Consists of: (5) Ref. 12 Polypropylene Rollers and (1) Ref. 7 O-Ring Gasket, and (2) Ref. 4 Viton Seals.

Repair Parts Kit No. 3430-0407 Consists of: (5) Ref. 12 Super Rollers, (1) Ref. 7 O-Ring Gasket, (2) Ref. 4 Viton Seals and (2) Ref. 3 Sealed Ball Bearings.

NO. AA17 - TEEVALVE

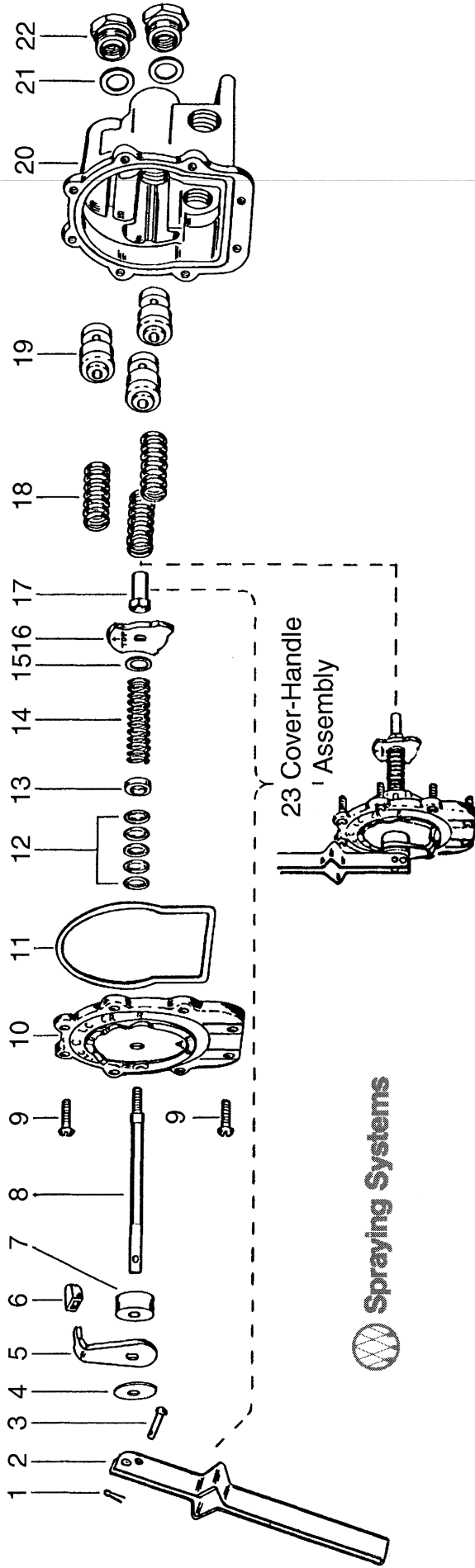

Item	Part No.	Description
*1	CP8012-1/2-SS	1/16" x 1/2" Cotter Pin, Stainless Steel
2	CP6849-1-I-ZP	Handle, Steel, Zinc Plated
*3	CP7206-I-ZP	Rivet, Steel, Zinc Plate
*4	CP6976-I-ZP	Handle Washer, Steel, Zinc Plated
5	CP12128-I-ZP	Selector Shield, Steel, Zinc Plated
*6	CP12127-CE	Selector Shield Tip, Celcon (Gray)
7	CP12129-CE	Spacer, Celcon (Gray)
8	CP6972-SS	Main Stem, Stainless Steel
*9	CP7980-I-ZP	Screws, Steel, Zinc Plated (8 Req'd)
10	CP12126-AL	Cover Plate, Aluminum
*11	CP6975-BU	Gasket, Buna-N
*12	CP5809-LEA	Packing, Thermo-Leather (5 Req'd)
13	CP12130-SS	Packing Gland, Stainless Steel
14	CP7254-SS	Main Spring, Stainless Steel
15	CP7987-SS	Washer, Stainless Steel
16	CP6971-AL	Selector Cam, Aluminum
17	CP6973-SS	Guide Nut, Stainless Steel

Item	Part No.	Description
18	CP6959-SS	Valve Spring, Stainless Steel (3 Req'd)
19	CP6956-CE	Valve Stem, Celcon (3 Req'd)
20	CP6934-1/2-AL	Body, Aluminum (For Models 17A thru 17F)
	CP6934-3/4-AL	Body, Aluminum (For Models 17G thru 17L)
	CP6934-1 1/2-AL	Body, Aluminum (For Models M thru S)
	CP6934-13/4-AL	Body, Aluminum (For Models T thru Y)
*21	CP6958-POL	Seat Plate, Polyethylene (3 Req'd)
22	CP7261-AL	Outlet Adapters, Aluminum (3 Req'd.) (For #17A, G, M, T)
	CP6957-AL	Outlet Adapters, Aluminum (3 Req'd.) (For #17B, H, N, U)
	CP7262-AL	Outlet Adapters, Aluminum (3 Req'd.) (For #17C, I, P, V)
	CP7350-AL	Outlet Adapters, Aluminum (3 Req'd.) (For #17D, J, Q, W)
	CP7735-AL	Outlet Adapters, Aluminum (3 Req'd.) (For #17E, K, R, X)
	CP7902-AL	Outlet Adapters, Aluminum (3 Req'd.) (For #17F, L, S, Y)
23		Cover Handle Assembly (Includes all items 1 thru 17)
	AB17-KIT	Spare Parts Kit (Includes all items with *)
	AB17.1-KIT	Spare Parts Kit (Includes #AB17 - Kit plus item #10 cover plate)

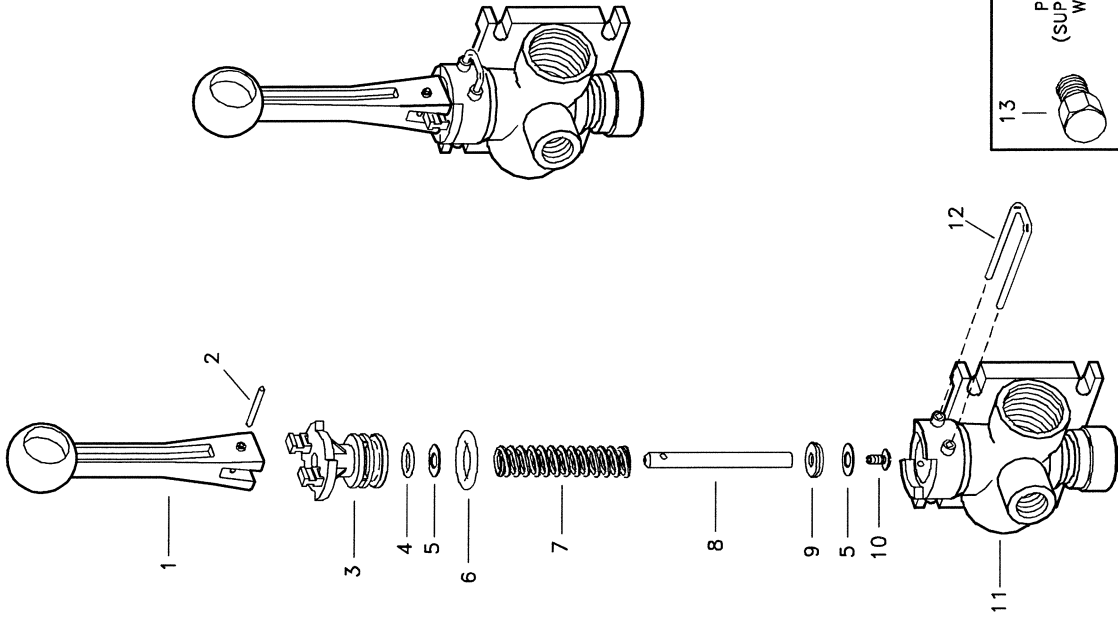

ITEM	PART NO.	DESCRIPTION
1	CP36301-NY	HANDLE, NYLON (GRAY)
2	CP36308-SS	GROOVE PIN, TYPE 303 STAINLESS STEEL
3	CP36302-PP	BODY INSERT, POLYPROPYLENE (BLACK)
4	CP7717-2/108-VI	O-RING, VITON
5	CP36307-PPB	WASHER, POLYPROPYLENE (BLACK) 2 REQ'D
6	CP7717-2/209-VI	O-RING, VITON
7	CP36306-302SS	SPRING, TYPE 302 STAINLESS STEEL
8	CP36304-SS	STEM, TYPE 303 STAINLESS STEEL
9	CP38726-VI	SHUT-OFF WASHER, VITON
10	CP38725-SS	PHILLIPS HEAD SCREW, TYPE 302 STAINLESS STEEL
11	CP36303-PP	BODY (NPT), POLYPROPYLENE (BLACK) (FOR MODEL AAB6B)
	CPB36303-PP	BODY (BSPT), POLYPROPYLENE (BLACK) (FOR MODEL AAB6B)
12	CP36309-302SS	RETAINING CLIP, TYPE 302 STAINLESS STEEL
13	8400-1/4-PPB	PIPE PLUG (NPT), POLYPROPYLENE (BLACK) (FOR MODEL AAB6B)
	B8400-1/4-PPB	PIPE PLUG (BSPT), POLYPROPYLENE (BLACK) (FOR MODEL AAB6B)
No. AAB6B DIRECTOVALVE MANUAL CONTROL VALVE (NPT THREADS)		
No. AAB6B DIRECTOVALVE MANUAL CONTROL VALVE (BSPT THREADS)		

PK-AB6B-KIT SPARE PARTS KIT (INCLUDES ALL ITEMS MARKED WITH *)

13
PIPE PLUG
(SUPPLIED LOOSE
WITH UNIT)

DESCRIPTION:
AAB6B
DIRECTOVALVE®
MANUAL CONTROL VALVE
(NPT & BSPT VERSIONS)



Spraying Systems Co.
Spray Nozzles and Accessories
P.O. Box 7900 - Wheaton, Il. 60189-7900

Rev. No. 1
Ref.

Parts List No.
PL 68

SHEET OF

Model 2502 Electric Boom Valve

8 GPM 175 PSI 12 Volt

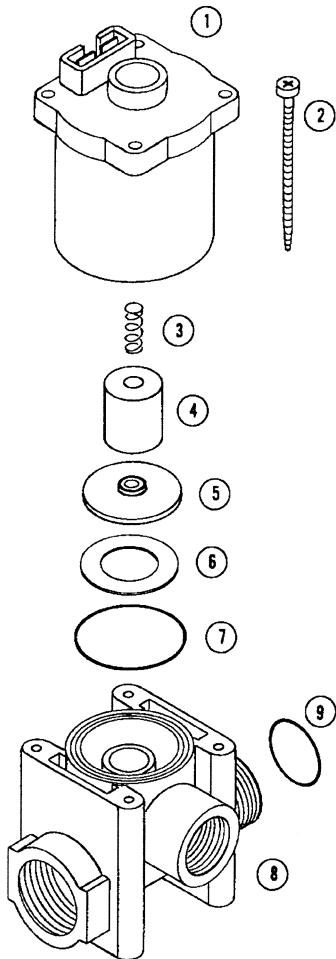

PARTS LIST

Ref.	Part No.	Description	No. Req.
1	2384	Coil.....	1
2		No. 8 x 2 1/2 Screw	4
3	*2315	Spring.....	1
4	2383	Plunger.....	1
5	*2307	Disc Valve Viton	1
6	*2363	Washer.....	1
7	*2314	"O" Ring, 028 Viton	1
8	2295	Valve Body	1
9	2166	"O" Ring, 018	1
	2352	Repair Kit. Consists of items marked with *.	

DISASSEMBLY

It is not necessary to take the valve out of the line to service it. The valve can be disassembled by removing the four No. 8 x 2 1/2 screws (2).

ASSEMBLY

Assemble the valve as shown in the illustration. Be sure the small seat on the disc valve (5) is in the up position. Do not over tighten the No. 8 x 2 1/2 screws.

TEXAS INDUSTRIAL REMCOR, INC.

BOX 3704 • TEMPLE, TEXAS 76505 • (254) 982-4236

No. 2502 Solenoid Valve

SPECIFICATIONS

- Valve HousingGlass Filled Nylon
- Wetted Metal Parts430 Stainless Steel
- Seal and "O" RingsViton
- CoilEpoxy Encapsulated
- Terminals1/4" Male Tabs
- Voltage12 Volt. DC.
- Current1.7 AMP at 12 Volt.
- Operating Pressure175 PSI Maximum
- Flow0-8 G.P.M. 3.6 cv.
- Temperature120°F Maximum

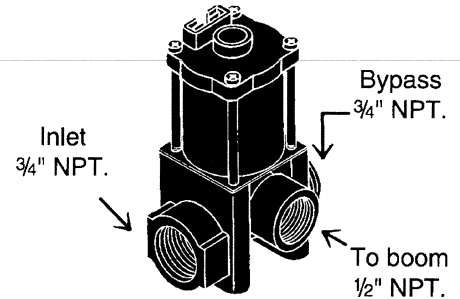

INSTALLATION

The valves can be plumbed as shown in the illustration. It is advisable to install a strainer ahead of the valves. Note the arrows for flow direction.

The coil will radiate heat; therefore, it should not be enclosed. If the coil fails, the valve can be opened by removing the plunger(4).

After usage, always flush and drain valves.

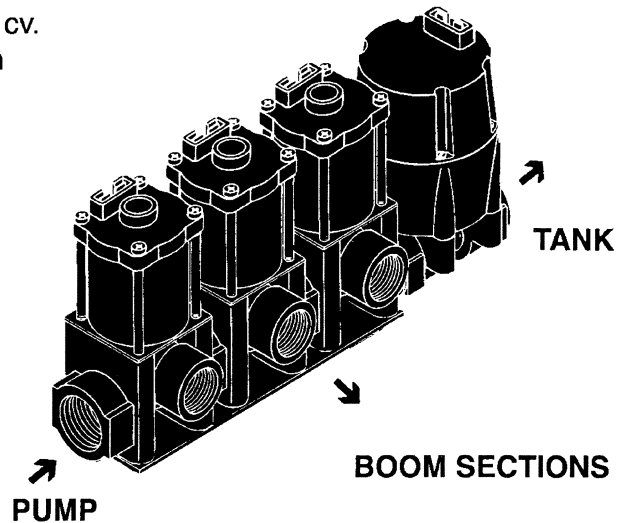

Mounting

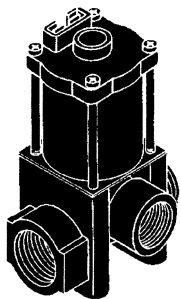

↑ 4 Mounting holes
.17 Dia. x 1.00 Deep
Use No. 10 x 3/4" long screws

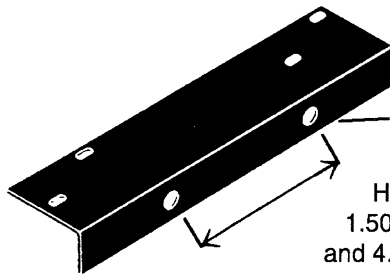

1 1/32 DIA.
Hole Spacing
1.50" for 2148 bracket
and 4.00" for 2149 and 2151 brackets

MOUNTING BRACKETS ARE NOT INCLUDED WITH VALVES. THEY MAY BE ORDERED FROM FOLLOWING AS DESIRED:

- 2148 Mounting Bracket for 2502-1 single valve
- 2149 Mounting Bracket for 2502-2 double valves
- 2151 Mounting Bracket for 2502-3 triple valves

Trouble Shooting

Valve fails to open:

1. Check if the coil (1) is burned out.
2. Remove the coil (1) and check if the plunger (4) is stuck.
3. Check the control box and wiring harness for broken wires, bad switches and blown fuses.

Valve fails to shut off:

1. Remove the coil (1) and check if the plunger (4) is stuck.
2. Check if the spring (3) is broken.
3. Check for proper electrical connections.

No. 43L & No. 43H GUNJETS (13" Extension)



Item	Part No.	Description
1	Brass (#43-) 1325-AL	Cap, Brass or Aluminum
2	D-**	Orifice disc, hardened stainless steel
*3	4743-NY	Gasket, nylon
4	10566-AL	Nozzle housing, brass or aluminum
*5	10565-AL	Seat plug, seat plate, washer & core subassy.
6	10571-AL	Guide vane, brass or aluminum
7	6943-AL	Gasket, aluminum (2 Req'd)
8	19238-416SS	Stem, type 416 stainless steel
9	6604-AL	Tubing, brass or aluminum
10	6492-AL	Inlet body, brass or aluminum
*11	6601-302SS	Packing washer, type 302 stainless steel
*12	6602-LEA	Packing, leather (3 Req'd) (Standard)
	6602-TEF	Packing, teflon (3 Req'd) (Optional)
13	19237-AL	Packing screw, brass or aluminum
14	6599-IZP	Locknut, brass or steel-zinc plated
15	9641-INP	Stem nut, steel-nickel plated
16	6595-SS	Trigger stop spring, stainless steel
17	7991-IZP	Washer, steel-zinc plated
18	6597-INP	Trigger guide, steel-nickel plated
19	6591-SS	Spring stud, stainless steel
20	6589-IZP	Stop adj nut, steel-zinc plated
21	6594-SS	Spring for Stop adj nut, stainless steel
22	6588-IZP	Spring screw, steel-zinc plated
23	6592-302SS	Spring guide washer, type 302 stainless steel
24	6593-1-SS	Main spring, stainless steel (For #43L-)
	6593-2-SS	Main spring, stainless steel (For #43H-)
25	14477-1-AL	Handle body, aluminum
26	7623-IZP	Rivet, steel-zinc plated (2 Req'd)
27	6509-INP	Trigger, steel-nickel plated
28	6510-INP	Trigger stop, steel-nickel plated
29	11757-INP	Screw, steel-nickel plated
30	13798-INP	Trigger Guard, steel-nickel plated
Gunjet No. 43L- Brass, complete, for pressures up to 200 PSI		
Gunjet No. 43L-AL- Aluminum, complete, for pressures up to 200 PSI		
Gunjet No. 43H- Brass, complete, for pressures from 200 to 800 PSI		
Gunjet No. 43H-AL- Aluminum, complete, for pressures from 200 to 800 PSI		
AB43-KIT Spare Parts Kit (Includes all items marked with *)		
AB43-AL-KIT Spare Parts Kit (Includes all items marked with *)		
ABCK43-KIT (Conversion kit for Adj. stem) - items 8, 13 & 15)		
ABCK43-AL-KIT (Conversion Kit for Adj. Stem) - items 8, 13 & 15)		

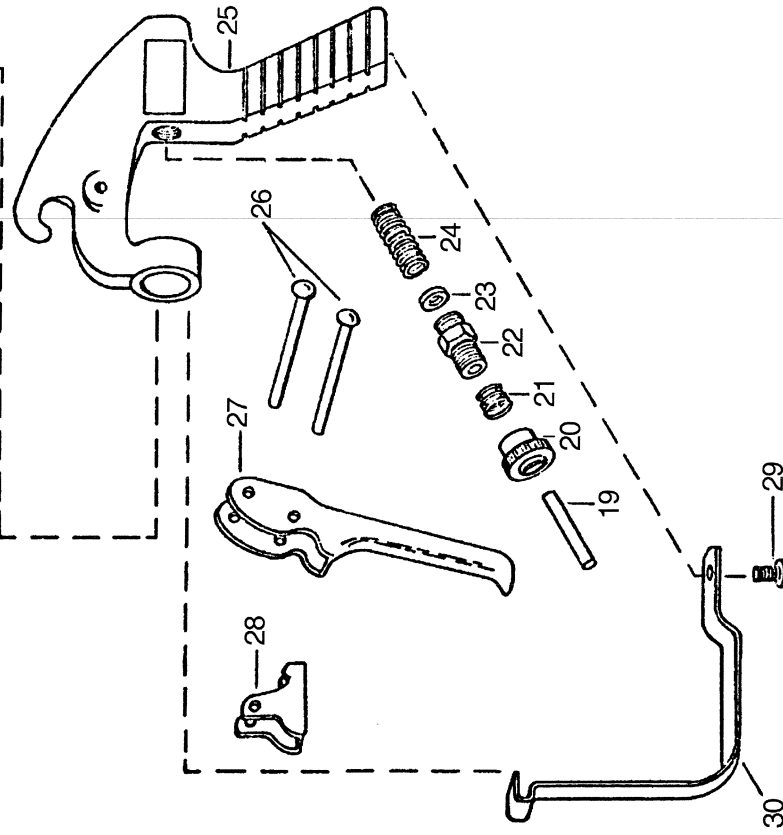

**Specify Orifice Disk Size

MOUNTING AND ASSEMBLY INSTRUCTION

FOR 3 POINT HITCH SPRAYERS 200 AND 300 GALLON 12 ROW

Mount the sprayer on tractor and use top link to level frame. Use the lift arm adjustments to level tank and frame laterally. Install lift arm stabilizer to eliminate side sway. Attach the pump to tractor.

FOR PTO ROLLER PUMPS:

IF YOU EVER INTEND TO USE ROUND-UP OR ANY SUCH CHEMICAL YOU MUST USE THE ROUND-UP READY PUMP.

Install the pump on the tractor PTO shaft and make sure that the pump you are using is recommended for PTO speed which you intend to use. If in doubt ask your dealer.

If your pump is equipped with a quick coupler, make sure that it is locked onto tractor PTO shaft and tighten set screw.

Fasten the stabilizer to a fixed point on the tractor so that pump will not rotate with shaft.

FOR PTO DRIVEN CENTRIFUGAL PUMPS:

Make sure pump is recommended for the PTO speed which you intend to use. If in doubt ask your dealer for assistance.

Slip the PTO coupler all the way up on the splined tractor shaft and tighten all set screws making sure the pump is properly centered on the shaft to eliminate wobble.

Make sure the outlet (discharge) port on the pump is mounted in the VERTICAL POSITION. If you are unable to mount the pump in this manner as is, the rear housing plate may be removed and rotated to a vertical position. This is necessary to insure proper priming of pump.

Fasten the stabilizer to a fixed point on the tractor so the pump will not rotate with shaft.

FOR HYDRAULIC DRIVEN CENTRIFUGAL PUMPS:

Mount a hydraulic centrifugal pump only after reading the complete instruction manual provided by pump manufacturer.

If you do not have this manual, ask your dealer for assistance.

A hydraulic motor driven centrifugal pump is extremely versatile in regard to where it may be mounted, however, one thing you must keep in mind is that the pump must be mounted at /or below liquid level of the tank.

IMPORTANT: Be sure to connect hydraulic hoses from the tractor outlet to the hydraulic motor inlet and the tractor return line to the outlet of the hydraulic motor. These hoses must be hooked correctly to

achieve the correct rotation on the pump and to prevent damage to the unit or system. Pump rotation is clockwise when facing the suction port of pump.

FOR DIAPHRAGM PUMPS:

Always mount pump with the oil sight tube in an upwards position. DO NOT OPERATE without safety shields in place.

BEFORE RUNNING THE PUMP:

- A. Be sure that oil is halfway up the sight tube. If necessary, fill to correct level with 20W-30W non detergent oil.
- B. Be sure the suction hose barb is tightly screwed onto the suction union.
- C. Do not restrict the pump on the suction side. Use a 2-braid suction hose of at least the same inside diameter as the pump ports—larger with long suction lines. Keep the line as short as possible. Avoid all unnecessary bends, elbows or kinks in hose. Make sure all connections are tight and do not leak air.
- D. Be sure to use line strainer with 20 mesh, this comes standard on any VAN,S sprayer with diaphragm pumps
- E. Be sure to check charge in pulsation damper. Damper should be charged with air to 20 % of operating pressure. Minimum charge should be 5 PSI.
- F. RUN THE PUMP AT ZERO PRESSURE for one minute to remove air from the system. Do not exceed the pump's recommended maximum speed and pressure. There will be no performance advantage and pump life will be reduced. Pumps run over recommended speed or pressure are not subject to warranty.
- G. MAINTENANCE:
 - 1. After use, flush pump with clean water.
 - 2. Change oil every 200 hours or at the end of every spray season. To drain oil from pump, remove the drain plug, (see manufacturers manual), and slowly turn pump shaft until all oil is drained. To fill pump with oil, slowly pour oil into sight tube while turning the pump shaft. Turning the pump shaft purges air out of the crankcase.
 - 3. For winter storage or if freezing conditions will be encountered, flush pump with 50/50 mixture of water and antifreeze.

NOTES TO REMEMBER FOR ALL PUMPS:

- A. Be sure to check all arrows on the pump that indicate proper rotation of pump.
- B. Be sure pump is correct for the PTO speed you intend to use.
- C. Be sure that the suction hose from tank to pump is as short as possible—cut if necessary—and be sure that hose is not kinked or collapsed—run it as straight as possible.
- D. Be sure that all hose clamps are tight and in place.
- E. **NEVER OPERATE ANY SPRAYER PUMP DRY**—Be sure pump is primed and supplied with liquid when it is operating. Damage will occur to the seals in a roller pump and also to the rollers. Damage will occur to seal of a centrifugal pump if operated dry.

When starting a new pump and every time it is operated thereafter, the pump should start displacing liquid within 18 seconds. If it does not, stop the pump and check all hoses, valves, and strainer between pump and tank.

BOOM ASSEMBLY AND SETUP:

The boom on the 200 and 300 gallon 12 row sprayers are detached from boom yoke, (item 20 page 8), for shipping, the chains, (item 14 page 8), are left connected. Reattached booms, with bolt, (item 21 page 8), and nut, (item 19 page 8), if necessary. Make sure the tip bodies face to the rear of sprayer. Be sure boom feed line hoses are correctly connected to control valve. You can determine this by operating sprayer with clear water, and switching hoses if necessary. **BE SURE YOU DO NOT SWITCH ANY HOSES OTHER THAN BOOM FEED LINES.**

Adjust booms to proper height for job you wish to do. If you are unable to determine what is correct for your job, please contact your local county agent or ask your vans dealer. In most cases nozzles are placed 19-20 inches above surface to be sprayed.

Be sure that your booms are level so that the nozzles on outer ends are exactly the same height as those in center.

Before going to the field look at each and every nozzle, make sure they are all the same size, and have tip strainers in place and are clean.

BEFORE GOING TO THE FIELD:

1. Look inside your new sprayer tank and make sure it is clean.
2. Fill tank about half full with clean water—**DO NOT ADD ANY CHEMICALS.**
3. Make sure all valves in the suction line on bottom of tank are full open.
4. Turn adjusting screw on pressure regulator valve in the counter-clockwise direction until it is almost all the way out.
5. Start pump slowly and increase speed of tractor to about 1200 RPM while checking to make sure liquid is passing through the pump and back into tank.
6. Turn adjusting screw on pressure regulator clockwise and increase pressure to approximately 10 PSI above the pressure you expect to use in field.
7. Open boom control valve and check all fittings for possible leaks. Check all hose connections and make sure all clamps are tight.
8. **MAKE SURE AT NO TIME WILL THE PRESSURE EXCEED THE CAPACITY OF THE PRESSURE GAUGE.**
9. Inspect the inside of your tank for good agitation while pump is in operation. Your VAN, S Sprayer gives full time agitation while pump is running. If you do not have good agitation, it is possible that some piece of foreign material can enter the system and clog agitator. Check if necessary by removing the agitator for inspection.

If the preceding steps have been followed properly and all corrective action necessary has been taken, you are now ready to calibrate your unit for field operation.

CALIBRATION:

It is necessary to calibrate your sprayer before beginning the spray job. We will not attempt here to give you a calibration procedure, however we suggest the section in the Spraying System catalog on calibration, your local or state pesticide manual, or calling your VAN's dealer. You can also look on page 11 of this manual for the application table for our standard tip, which unless you specified another tip, is a **TP8003 brass fan tip**.

No matter what method you use, or what you use, please remember the following points:

1. Always calibrate with clean water only.
2. Always calibrate under field conditions.
3. Never rely on a tractor speedometer for accuracy.
4. Make sure all nozzles are the same size, are spraying properly, and all strainers are clean.
5. Due to long boom lines, there can be a loss of pressure between pressure gauge and tips. It is usually normal to indicate a slightly higher reading on gauge, (approximately 5-8 PSI) than that indicated by application chart. For this reason calibrate your sprayer often.

CAUTIONS AND PRE-CAUTIONS, (PLEASE READ CAREFULLY)

If you have followed all the instructions up to this point, your new VAN'S SPRAYER is ready to go to work and do a good job. These last instructions can and will make your spraying job more pleasant.

- A. NEVER OPERATE SPRAYER WITHOUT PROPER SAFETY PRECAUTIONS.**
- B. ALWAYS FILL TANK AT LEAST HALF FULL AND HAVE PUMP OPERATING BEFORE ADDING CHEMICALS. IF YOU ARE USING WETTABLE POWDER, PRE-MIX IN A BUCKET OF WATER BEFORE ADDING TO TANK.**
- C. NEVER OPERATE PUMP AFTER TANK IS EMPTY-DO NOT OPERATE DRY.**
- D. ALWAYS ADJUST PRESSURE REGULATOR WITH SPRAYER IN OPERATION AND NEVER EXCEED THE CAPACITY OF THE GAUGE.**
- E. NEVER USE A METAL OBJECT TO CLEAN A NOZZLE, A TOOTHPICK, TOOTHBRUSH, MATCH, OR AIR WILL DO A BETTER AND SAFER JOB.**
- F. WHEN TRANSPORTING YOUR SPRAYER ON A ROAD OR HIGHWAY, BE SURE TO SECURE THE BOOMS IN THE BRACKETS PROVIDED FOR THIS PURPOSE. ALWAYS USE FLASHER LIGHTS OR OTHER DEVICES TO GIVE ADEQUATE WARNING TO OTHER VEHICLES.**
- G. REMEMBER-NOZZLES DO NOT CAUSE SPRAY PATTERN DISTORTION AND VARYING SPRAY VOLUME RATES. REPLACE NOZZLES AS OFTEN AS NEEDED TO ASSURE PROPER AND UNIFORM SPRAY COVERAGE AND RATES. CALIBRATE DAILY. STAINLESS STEEL NOZZLES PROVIDE THE MOST WEAR RESISTANCE WHEN COMPARED TO OTHER TIP MATERIAL.**
- H. ALWAYS USE CLEAN WATER AND CHECK STRAINER DAILY.**

- I. CHECK AGITATION IN TANK FREQUENTLY—AT LEAST TWICE DAILY.
- J. KEEP ALL HOSES IN GOOD SHAPE – REPLACE WORN OR DAMAGED HOSE AS NEEDED-BE SURE SUCTION HOSE IS IN GOOD CONDITION.
- K. CLEAN UP WHEN JOB IS DONE.ALWAYS CLEAN SPRAYER AFTER EACH USE.
- L. NEVER CHANGE FROM ONE CHEMICAL TO ANOTHER WITHOUT THOROUGHLY CLEANING SPRAYER.

CLEANING- STORING-MAINTENANCE

The least expensive thing you can do to prolong your new sprayers life is to keep it clean. Please follow these simple instruction after spraying job is done.

1. Clean thoroughly-Remove any chemical residues from tank,pump,boom strainers,and nozzles by flushing completely the entire system with clean water and follow with a solution of approximately ONE QUART of household AMMONIA to25 gallons water.
2. Remove all nozzle tips and strainers from booms and clean thoroughly with a toothbrush or toothpick. Leave nozzle tip to soak in can of oil or diesel fuel.
3. DRAIN TANK COMPLETELY and leave it to dry outside. Make sure all chemical has been removed THIS IS VERY IMPORTANT WITH WETTABLE POWDERS.
4. Remove pump and make sure no liquid is left inside. Fill pump with radiator rust inhibitor and plug outlets keep inside during storage.
5. Drain complete system and fill with antifreeze during winter storage to prevent freezing.
6. Store complete sprayer in dry place out of weather. Keeping sprayer out sunlight will lessen the UV effects on tank.
7. Caution: Never change from one type of chemical to another without thoroughly cleaning sprayer.

TROUBLE SHOOTING THE SPRAYER

PROBLEM	PROBABLE CAUSE	POSSIBLE REMEDY
Erratic pressure indication on pressure gauge	air leaking into suction line	Tighten all fittings and hoses between pump and tank
	Trash in control valve or pressure gauge	Remove and clean parts
Pressure gauge fluctuates excessively	Suction line kinked or clogged	Remove suction line and clean-check tank and strainer
	Air leak in suction hose	Replace hose
	Suction hose collapsed	Replace hose
	Pump is sucking in air through the suction line or air has not been entirely evacuated from strainer	Examine the suction hose and make sure it is firmly secured. Run the pump with outlet hose open to evacuate air from pump
Pump loses suction	Suction strainer clogged	Clean strainer and tank
	Air leak in suction hose	Replace hose
	Suction hose collapsed	Replace hose
	Pump air locked	Remove discharge line and pump liquid through pump
	Pump worn and clearances too great	Replace or repair pump
Pump does not draw water	Seals worn out or deteriorated	Replace pump seals
	One or more valves are seated improperly	Examine the valve seatings and clean them
	Suction line is plugged or collapsed clogged strainer	Examine suction line Clean strained
Noisy pump	Excessive pump speed	Slow the pump
	Air leak in suction line	Replace suction hose
	Partially clogged strainer	Clean strainer
Pump shows decreased capacity	Suction strainer clogged	Clean strainer
	Air leak in suction hose	Replace suction hose
	Moving parts worn	Replace worn parts
	Worn seal	Replace seal
	Pump roller stuck	Clean pump inside
	Pump operating too slow	Speed up pump
	Nozzles too large for capacity of pump	Use smaller nozzles or reduce number of nozzles on boom
Pump leaks	Worn out seal	Replace seal

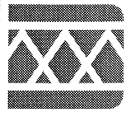

TeeJet® *VisiFlo® Flat Spray Tips*

Features:

- Tapered edge flat spray pattern for uniform coverage in broadcast spraying.
- VisiFlo color-coded version available in stainless steel, ceramic and polymer in 80° or 110° spray angles in selected sizes.
- Available in ceramic 80° capacities 01–02 and 110° capacities 01–015. See XR and XRC TeeJet® tips on pages 12 and 13 for larger capacities.
- Standard version (not color-coded) available in 15°, 25°, 40°, 50° and 65° spray angles in brass, stainless steel or hardened stainless steel.
- See page 39 for TeeJet even flat spray tips.
- Automatic spray alignment with 25612-^{*}-NYR Quick TeeJet® cap and gasket. Reference page 63 for more information.
- Automatic spray alignment for sizes 10 through 20 with 25610-^{*}-NYR Quick TeeJet cap and gasket. Reference page 63 for more information.

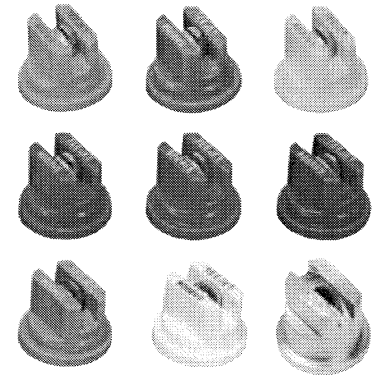
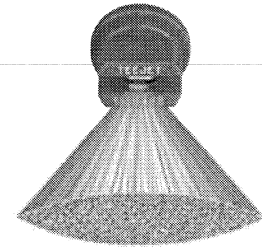

Tip Model	PSI	DROP SIZE		CAPACITY ONE NOZZLE IN GPM	CAPACITY ONE NOZZLE IN OZ./MIN.	20°											
		80°	110°			GPA											
						4 MPH	5 MPH	6 MPH	8 MPH	10 MPH	12 MPH	15 MPH	20 MPH	2 MPH	3 MPH	4 MPH	5 MPH
TP650050†	30			0.043	5.5	3.2	2.6	2.1	1.6	1.3	1.1	0.85	0.64	0.15	0.10	0.07	0.06
TP800050†	35			0.047	6.0	3.5	2.8	2.3	1.7	1.4	1.2	0.93	0.70	0.16	0.11	0.08	0.06
TP1100050†	40			0.050	6.4	3.7	3.0	2.5	1.9	1.5	1.2	0.99	0.74	0.17	0.11	0.09	0.07
TP1100067†	50			0.056	7.2	4.2	3.3	2.8	2.1	1.7	1.4	1.1	0.83	0.19	0.13	0.10	0.08
TP650067†	60			0.061	7.8	4.5	3.6	3.0	2.3	1.8	1.5	1.2	0.91	0.21	0.14	0.10	0.08
TP800067†	30			0.058	7.4	4.3	3.4	2.9	2.2	1.7	1.4	1.1	0.86	0.20	0.13	0.10	0.08
TP800067†	35			0.063	8.1	4.7	3.7	3.1	2.3	1.9	1.6	1.2	0.94	0.21	0.14	0.11	0.09
TP1100067†	40			0.067	8.6	5.0	4.0	3.3	2.5	2.0	1.7	1.3	0.99	0.23	0.15	0.11	0.09
TP1100067†	50			0.075	9.6	5.6	4.5	3.7	2.8	2.2	1.9	1.5	1.1	0.26	0.17	0.13	0.10
TP1100067†	60			0.082	10	6.1	4.9	4.1	3.0	2.4	2.0	1.6	1.2	0.28	0.19	0.14	0.11
TP6501†	30	F	F	0.087	11	6.5	5.2	4.3	3.2	2.6	2.2	1.7	1.3	0.30	0.20	0.15	0.12
TP8001	35	F	F	0.094	12	7.0	5.6	4.7	3.5	2.8	2.3	1.9	1.4	0.32	0.21	0.16	0.13
TP11001	40	F	F	0.10	13	7.4	5.9	5.0	3.7	3.0	2.5	2.0	1.5	0.34	0.23	0.17	0.14
TP11001	50	F	F	0.11	14	8.2	6.5	5.4	4.1	3.3	2.7	2.2	1.6	0.37	0.25	0.19	0.15
TP11001	60	F	F	0.12	15	8.9	7.1	5.9	4.5	3.6	3.0	2.4	1.8	0.41	0.27	0.20	0.16
TP65015†	30	F	F	0.13	17	9.7	7.7	6.4	4.8	3.9	3.2	2.6	1.9	0.44	0.29	0.22	0.18
TP80015	35	F	F	0.14	18	10.4	8.3	6.9	5.2	4.2	3.5	2.8	2.1	0.48	0.32	0.24	0.19
TP80015	40	F	F	0.15	19	11.1	8.9	7.4	5.6	4.5	3.7	3.0	2.2	0.51	0.34	0.26	0.20
TP110015	50	F	F	0.17	22	12.6	10.1	8.4	6.3	5.0	4.2	3.4	2.5	0.58	0.39	0.29	0.23
TP110015	60	F	F	0.18	23	13.4	10.7	8.9	6.7	5.3	4.5	3.6	2.7	0.61	0.41	0.31	0.24
TP6502†	30	M	F	0.17	22	12.6	10.1	8.4	6.3	5.0	4.2	3.4	2.5	0.58	0.39	0.29	0.23
TP8002	35	M	F	0.19	24	14.1	11.3	9.4	7.1	5.6	4.7	3.8	2.8	0.65	0.43	0.32	0.26
TP11002	40	M	F	0.20	26	14.9	11.9	9.9	7.4	5.9	5.0	4.0	3.0	0.68	0.45	0.34	0.27
TP11002	50	M	F	0.22	28	16.3	13.1	10.9	8.2	6.5	5.4	4.4	3.3	0.75	0.50	0.37	0.30
TP11002	60	M	F	0.24	31	17.8	14.3	11.9	8.9	7.1	5.9	4.8	3.6	0.82	0.54	0.41	0.33
TP6503†	30	M	F	0.26	33	19.3	15.4	12.9	9.7	7.7	6.4	5.1	3.9	0.88	0.59	0.44	0.35
TP8003	35	M	F	0.28	36	21	16.6	13.9	10.4	8.3	6.9	5.5	4.2	0.95	0.63	0.48	0.38
TP11003	40	M	F	0.30	38	22	17.8	14.9	11.1	8.9	7.4	5.9	4.5	1.0	0.68	0.51	0.41
TP11003	50	M	F	0.34	44	25	20	16.8	12.6	10.1	8.4	6.7	5.0	1.2	0.77	0.58	0.46
TP11003	60	M	F	0.37	47	27	22	18.3	13.7	11.0	9.2	7.3	5.5	1.3	0.84	0.63	0.50
TP6504†	30	M	M	0.35	45	26	21	17.3	13.0	10.4	8.7	6.9	5.2	1.2	0.79	0.60	0.48
TP8004	35	M	M	0.37	47	27	22	18.3	13.7	11.0	9.2	7.3	5.5	1.3	0.84	0.63	0.50
TP11004	40	M	M	0.40	51	30	24	19.8	14.9	11.9	9.9	7.9	5.9	1.4	0.91	0.68	0.54
TP11004	50	M	F	0.45	58	33	27	22	16.7	13.4	11.1	8.9	6.7	1.5	1.0	0.77	0.61
TP11004	60	M	F	0.49	63	36	29	24	18.2	14.6	12.1	9.7	7.3	1.7	1.1	0.83	0.67
TP6505†	30	C	M	0.43	55	32	26	21	16.0	12.8	10.6	8.5	6.4	1.5	0.97	0.73	0.58
TP8005	35	M	M	0.47	60	35	28	23	17.4	14.0	11.6	9.3	7.0	1.6	1.1	0.80	0.64
TP11005	40	M	M	0.50	64	37	30	25	18.6	14.9	12.4	9.9	7.4	1.7	1.1	0.85	0.68
TP11005	50	M	M	0.56	72	42	33	28	21	16.6	13.9	11.1	8.3	1.9	1.3	0.95	0.76
TP11005	60	M	F	0.61	78	45	36	30	23	18.1	15.1	12.1	9.1	2.1	1.4	1.0	0.83
TP6506†	30	C	C	0.52	67	39	31	26	19.3	15.4	12.9	10.3	7.7	1.8	1.2	0.88	0.71
TP8006	35	C	C	0.56	72	42	33	28	21	16.6	13.9	11.1	8.3	1.9	1.3	0.95	0.76
TP11006	40	C	C	0.60	77	45	36	30	22	17.8	14.9	11.9	8.9	2.0	1.4	1.0	0.82
TP11006	50	C	C	0.67	86	50	40	33	25	19.9	16.6	13.3	9.9	2.3	1.5	1.1	0.91
TP11006	60	C	C	0.73	93	54	43	36	27	22	18.1	14.5	10.8	2.5	1.7	1.2	0.99
TP6508†	30	C	C	0.69	88	51	41	34	26	20	17.1	13.7	10.2	2.3	1.6	1.2	0.94
TP8008	35	C	C	0.75	96	56	45	37	28	22	18.6	14.9	11.1	2.6	1.7	1.3	1.0
TP11008	40	C	C	0.80	102	59	48	40	30	24	19.8	15.8	11.9	2.7	1.8	1.4	1.1
TP11008	50	C	C	0.89	114	66	53	44	33	26	22	17.6	13.2	3.0	2.0	1.5	1.2
TP11008	60	C	C	0.98	125	73	58	49	36	29	24	19.4	14.6	3.3	2.2	1.7	1.3
TP6510†	30			0.87	111	65	52	43	32	26	22	17.2	12.9	3.0	2.0	1.5	1.2
TP8010†	35			0.94	120	70	56	47	35	28	23	18.6	14.0	3.2	2.1	1.6	1.3
TP8010†	40			1.00	128	74	59	50	37	30	25	19.8	14.9	3.4	2.3	1.7	1.4
TP11010†	50			1.12	143	83	67	55	42	33	28	22	16.6	3.8	2.5	1.9	1.5
TP11010†	60			1.22	156	91	72	60	45	36	30	24	18.1	4.1	2.8	2.1	1.7
TP6515†	30			1.30	166	97	77	64	48	39	32	26	19.3	4.4	2.9	2.2	1.8
TP8015†	35			1.40	179	104	83	69	52	42	35	28	21	4.8	3.2	2.4	1.9
TP8015†	40			1.50	192	111	89	74	56	45	37	30	22	5.1	3.4	2.6	2.0
TP11015†	50			1.68	215	125	100	83	62	50	42	33	25	5.7	3.8	2.9	2.3
TP11015†	60			1.84	236	137	109	91	68	55	46	36	27	6.3	4.2	3.1	2.5
TP6520†	30			1.73	221	128	103	86	64	51	43	34	26	5.9	3.9	2.9	2.4
TP8020†	35			1.87	239	139	111	93	69	56	46	37	28	6.4	4.2	3.2	2.5
TP8020†	40			2.00	256	149	119	99	74	59	50	40	30	6.8	4.5	3.4	2.7
TP11020†	50			2.24	287	166	133	111	83	67	55	44	33	7.6	5.1	3.8	3.0
TP11020†	60			2.45	314	182	146	121	91	73	61	49	36	8.3	5.6	4.2	3.3

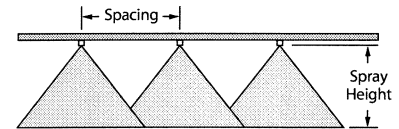

Optimum Spray Height

Tip Angle	Optimum Spray Height
65°	35"
80°	30"
110°	20"

See pages 173–187 for drop size classification, useful formulas and information.

How to order:

Specify tip number.

Examples:

- TP8002VS – Stainless Steel with VisiFlo color-coding
- TP11002VP – Polymer with VisiFlo color-coding
- TP11001VK – Ceramic with VisiFlo polymer color-coding
- TP11002-HSS – Hardened Stainless Steel
- TP8002-SS – Stainless Steel
- TP8002 – Brass

Note: Always double check your application rates. Tabulations are based on spraying water at 70°F (21°C).
† Available in all brass, stainless steel and hardened stainless steel only.



$$A = \frac{B+C}{D}$$

Technical Information

Useful Formulas

$$\begin{aligned} \text{GPM (Per Nozzle)} &= \frac{\text{GPA} \times \text{MPH} \times \text{W}}{5,940} \\ \text{GPM (Per Nozzle)} &= \frac{\text{GAL}/1000\text{FT}^2 \times \text{MPH} \times \text{W}}{136} \\ \text{GPA} &= \frac{5,940 \times \text{GPM (Per Nozzle)}}{\text{MPH} \times \text{W}} \\ \text{GAL}/1000\text{FT}^2 &= \frac{136 \times \text{GPM (Per Nozzle)}}{\text{MPH} \times \text{W}} \end{aligned}$$

- GPM – Gallons Per Minute
- GPA – Gallons Per Acre
- GAL/1000FT² – Gallons Per 1000 Square Feet
- MPH – Miles Per Hour
- W – Nozzle spacing (in inches) for broadcast spraying
 - Spray width (in inches) for single nozzle, band spraying or boomless spraying
 - Row spacing (in inches) divided by the number of nozzles per row for directed spraying

Nozzle Spacing

If the nozzle spacing on your boom is different than those tabulated, multiply the tabulated GPA coverages by one of the following factors.

20°	
Other Spacing (Inches)	Conversion Factor
8	2.5
10	2
12	1.67
14	1.43
16	1.25
18	1.11
22	.91
24	.83
30	.66

Useful Formulas for Roadway Applications

$$\text{GPLM} = \frac{60 \times \text{GPM}}{\text{MPH}} \quad \text{GPM} = \frac{\text{GPLM} \times \text{MPH}}{60}$$

GPLM = Gallons Per Lane Mile
Note: GPLM is not a normal volume per unit area measurement. It is a volume per distance measurement. Increases or decreases in lane width (swath width) are not accommodated by these formulas.

Measuring Travel Speed

Measure a test course in the area to be sprayed or in an area with similar surface conditions. Minimum lengths of 100 and 200 feet are recommended for measuring speeds up to 5 and 10 MPH, respectively. Determine the time required to travel the test course. To help ensure accuracy, conduct the speed check with a partially loaded (about half full) sprayer and select the engine throttle setting and gear that will be used when spraying. Repeat the above process and average the times that were measured. Use the following equation or the table at right to determine ground speed.

$$\text{Speed (MPH)} = \frac{\text{Distance (FT)} \times 60}{\text{Time (seconds)} \times 88}$$

Speeds



Speed in MPH	Time Required in SECONDS to Travel a Distance of:		
	100 Feet	200 Feet	300 Feet
1.0	68	136	205
1.5	45	91	136
2.0	34	68	102
2.5	27	55	82
3.0	23	45	68
3.5	19	39	58
4.0	17	34	51
4.5	15	30	45
5.0	14	27	41
5.5	—	25	37
6.0	—	23	34
6.5	—	21	31
7.0	—	19	29
7.5	—	18	27
8.0	—	17	26
8.5	—	16	24
9.0	—	15	23

Miscellaneous Conversion Factors

- One Acre = 43,560 Square Feet
- = 43.56 1000FT² Blocks
- = 0.405 Hectare
- One Hectare = 2.471 Acres
- One Gallon Per Acre
 - = 2.9 Fluid Ounces per 1000FT²
 - = 9.35 Liters Per Hectare
- One Gallon Per 1000FT² = 43.56 GPA
- One Mile = 5,280 Feet
- = 1,610 Meters
- = 1.61 Kilometers
- One Gallon = 128 Fluid Ounces
- = 8 Pints
- = 4 Quarts
- = 3.79 Liters
- = 0.83 Imperial Gallon
- One Pound Per Square Inch
 - = 0.069 bar
 - = 6.896 Kilopascals
- One Mile Per Hour = 1.609 Kilometers Per Hour

Suggested Minimum Spray Heights

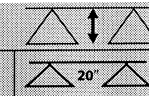
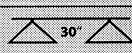
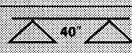
The nozzle height suggestions in the table below are based on the minimum overlap required to obtain uniform distribution. However, in many cases, typical height adjustments are based on a 1 to 1 nozzle spacing to height ratio. For example, 110° flat spray tips spaced 20 inches apart are commonly set 20 inches above the target.

	(Inches)			
				
 TeeJet® Standard, TJ	65°	22–24"	33–35"	NR*
TeeJet, XR, TX, DG, TJ	80°	17–19"	26–28"	NR*
TeeJet, XR, DG, TT, TTI, TJ, DGTJ, Ai, AiXR	110°	16–18"	20–22"	NR*
FullJet®	120°	10–18"***	14–18"***	14–18"***
FloodJet® TK, TF	120°	14–16"***	15–17"***	18–20"***

* Not recommended.
 ** Nozzle height based on 30° to 45° angle of orientation (see page 30 of catalog).
 *** Wide angle spray tip height is influenced by nozzle orientation. The critical factor is to achieve a double spray pTTtern overlap.

NOTES

